



**Count on it.**

**Operator's Manual**

**Workman® HDX-D Utility Vehicle  
with Bed**

Model No. 07385—Serial No. 316000001 and Up

Model No. 07385H—Serial No. 316000001 and Up

Model No. 07385TC—Serial No. 316000001 and Up

Model No. 07387—Serial No. 316000001 and Up

Model No. 07387H—Serial No. 316000001 and Up

Model No. 07387TC—Serial No. 316000001 and Up



## ⚠ WARNING

### CALIFORNIA Proposition 65 Warning

This product contains a chemical or chemicals known to the State of California to cause cancer, birth defects, or reproductive harm.

Diesel engine exhaust and some of its constituents are known to the State of California to cause cancer, birth defects, and other reproductive harm.

This machine is a utility vehicle intended to be used by professional, hired operators in commercial applications. It is primarily designed for the transport of implements used in such applications. This vehicle allows for the safe transport of an operator and one passenger in the identified seats. The bed of this vehicle is not suitable for any riders.

This product complies with all relevant European directives; for details, please see the separate product specific Declaration of Conformity (DOC) sheet.

It is a violation of California Public Resource Code Section 4442 or 4443 to use or operate the engine on any forest-covered, brush-covered, or grass-covered land unless the engine is equipped with a spark arrester, as defined in Section 4442, maintained in effective working order or the engine is constructed, equipped, and maintained for the prevention of fire.

## Introduction

Read this information carefully to learn how to operate and maintain your product properly and to avoid injury and product damage. You are responsible for operating the product properly and safely.

You may contact Toro directly at [www.Toro.com](http://www.Toro.com) for product and accessory information, help finding a dealer, or to register your product.

Whenever you need service, genuine Toro parts, or additional information, contact an Authorized Service Dealer or Toro Customer Service and have the model and serial numbers of your product ready. [Figure 1](#) identifies the location of the model and serial numbers on the product. Write the numbers in the space provided.

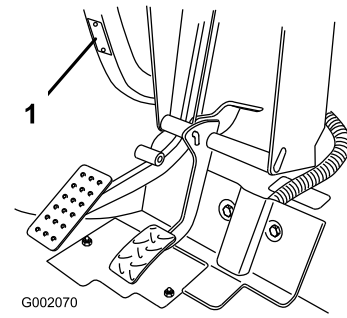

Figure 1

1. Model and serial number location

Model No. \_\_\_\_\_

Serial No. \_\_\_\_\_

This manual identifies potential hazards and has safety messages identified by the safety-alert symbol ([Figure 2](#)), which signals a hazard that may cause serious injury or death if you do not follow the recommended precautions.



Figure 2

1. Safety-alert symbol

This manual uses 2 words to highlight information.

**Important** calls attention to special mechanical information and **Note** emphasizes general information worthy of special attention.

# Contents

Safety .....	4	Lubrication .....	39
Safe Operating Practices .....	4	Greasing the Bearings and Bushings .....	39
Sound Pressure .....	7	Engine Maintenance .....	41
Vibration.....	7	Servicing the Air Cleaner .....	41
Safety and Instructional Decals .....	8	Changing the Engine Oil and Filter .....	41
Setup .....	13	Fuel System Maintenance .....	42
1 Installing the Steering Wheel.....	13	Checking the Fuel Lines and Connections .....	42
2 Installing the Rollover-Protection System (ROPS) .....	13	Servicing the Fuel Filter/Water Separator.....	42
3 Checking the Fluid Levels .....	14	Electrical System Maintenance .....	43
Product Overview .....	15	Servicing the Fuses .....	43
Controls .....	15	Jump-Starting the Machine .....	44
Specifications .....	18	Servicing the Battery .....	45
Attachments/Accessories.....	18	Drive System Maintenance .....	45
Operation .....	19	Changing the Front-Differential Oil.....	45
Operating the Cargo Box.....	19	Inspecting the Constant-Velocity Boot .....	46
Checking the Engine-Oil Level.....	20	Adjusting the Shift Cables.....	46
Adding Fuel.....	21	Adjusting the High-to-Low Cable .....	46
Checking the Coolant Level .....	22	Adjusting Differential-Lock Cable .....	46
Checking the Transaxle/Hydraulic-Fluid Level.....	23	Inspecting the Tires .....	47
Checking the High Flow Hydraulic-Fluid Level.....	23	Checking the Front-Wheel Alignment .....	47
Checking the Front-Differential-Oil Level.....	24	Cooling System Maintenance .....	48
Checking the Torque of the Wheel Nuts.....	24	Removing Debris from the Cooling System .....	48
Checking the Tire Pressure .....	25	Changing the Engine Coolant.....	48
Checking the Brake-Fluid Level .....	25	Brake Maintenance .....	49
Starting the Engine .....	26	Adjusting the Parking Brake .....	49
Driving the Vehicle.....	26	Adjusting the Brake Pedal.....	50
Stopping the Machine .....	26	Belt Maintenance .....	51
Shutting off the Engine .....	26	Adjusting the Alternator Belt .....	51
Breaking in a New Machine.....	26	Controls System Maintenance .....	51
Checking the Safety-Interlock System.....	27	Adjusting the Accelerator Pedal.....	51
Ensuring Passenger Safety .....	27	Adjusting the Clutch Pedal.....	52
Ensuring Proper Speed .....	28	Converting the Speedometer.....	52
Ensuring Proper Turning.....	28	Hydraulic System Maintenance .....	53
Ensuring Proper Braking.....	28	Changing the Hydraulic Fluid and Cleaning the Strainer.....	53
Preventing Tip Overs.....	28	Replacing the Hydraulic Filter .....	53
Operating on Hills.....	28	Changing the High-Flow Hydraulic Fluid and Filter .....	54
Loading and Dumping .....	29	Raising the Cargo Box in an Emergency .....	54
Using the Differential Lock.....	29	Cleaning .....	56
Using 4-Wheel Drive .....	30	Washing the Machine .....	56
Transporting the Machine.....	30	Storage .....	56
Towing the Machine .....	30		
Towing a Trailer with the Machine.....	31		
Using the Hydraulic Control .....	31		
Maintenance .....	33		
Recommended Maintenance Schedule(s) .....	33		
Operating in Adverse Conditions.....	34		
Pre-maintenance Procedures .....	35		
Using the Bed Support .....	35		
Removing the Full Bed.....	36		
Installing the Full Bed .....	36		
Raising the Machine.....	37		
Removing the Hood .....	38		
Installing the Hood.....	38		

# Safety

Improper use or maintenance by the operator or owner can result in injury. To reduce the potential for injury, comply with these safety instructions and always pay attention to the safety alert symbol, which means **Caution**, **Warning**, or **Danger**—personal safety instruction. Failure to comply with the instruction may result in personal injury or death.

The machine meets the requirements of SAE J2258.

## Safe Operating Practices

**Important:** This machine is designed primarily as an off-road vehicle and is not intended for extensive use on public roads.

When using the machine on public roads, follow all traffic regulations and use any additional accessories that may be required by law, such as lights, turn signals, slow-moving vehicle (SMV) signs, and others as required.

This machine was designed and tested to offer safe service when operated and maintained properly. Although hazard control and accident prevention are dependent upon the design and configuration of the machine, these factors are also dependent upon the awareness, concern, and proper training of the operator, maintenance, and storage of the machine. Improper use or maintenance of the machine can result in injury or death.

This machine has a different feel than what drivers experience with passenger cars or trucks. So take time to become familiar with your machine.

Not all of the attachments that adapt to the machine are covered in this manual. See the specific *Operator's Manual* provided with each attachment for additional safety instructions.

To reduce the potential for injury or death, comply with the following safety instructions:

## Supervisor's Responsibilities

- Make sure that the operators are thoroughly trained and familiar with the *Operator's Manual* and all labels on the vehicle.
- Be sure to establish your own special procedures and work rules for unusual operating conditions (e.g., slopes too steep for the safe operation of the machine).

## Before Operating

- This machine is designed to carry **only you**, the operator, and **1 passenger** in the seat provided by the manufacturer. **Never** carry any other passengers on the vehicle.
- Become familiar with the controls and know how to stop the engine quickly.
- **Never** operate the machine when tired, ill, or under the influence of drugs or alcohol.

- Always wear substantial shoes. Do not wear loose-fitting clothing, tie back long hair, and do not wear jewelry.
- Wearing safety glasses, safety shoes, and long pants are required by some local regulations.
- **Never** allow children to operate the machine. **Never** allow adults to operate it without proper instructions. Only trained and authorized persons should operate this machine.
- Always be aware of where bystanders are.
- Keep all shields, safety devices and decals in place. If a shield, safety device or decal is malfunctioning, illegible, or damaged, repair or replace it before operating the machine.
- Avoid driving when it is dark, especially in unfamiliar areas. If you must drive when it is dark, be sure to drive cautiously, use the headlights.
- Before operating the vehicle, always check all parts of the vehicle and any attachments. If something is wrong, **stop using vehicle**. Make sure that the problem is corrected before vehicle or attachment is operated again.
- Operate the machine only outdoors or in a well-ventilated area.

## Safe Handling of Fuels

- To avoid personal injury or property damage, use extreme care in handling fuel. Fuel is extremely flammable and the vapors are explosive.
- Do not smoke near the machine.
- Use only an approved nonmetal, portable fuel container.
- Static electric discharge can ignite fuel vapors in a fuel container that is not grounded. Never fill containers inside a vehicle or on a truck or trailer bed with a plastic liner. Remove the fuel container from the bed of the machine and place it on the ground and away from the vehicle before filling.
- Keep the nozzle in contact with the container while filling the fuel container. Remove equipment from bed of the machine before fueling it. Do not use a nozzle-lock-open device.
- Never remove the fuel cap or add fuel with the engine running.
- Allow engine to cool before refueling.
- Never refuel the machine indoors.
- Never store the machine or fuel container where there is an open flame, spark, or pilot light, such as on a water heater or on other appliances.
- Remove equipment from the truck or trailer and refuel it on the ground. If this is not possible, then refuel such equipment with a portable container rather than from a fuel-dispenser nozzle.

- If fuel is spilled on clothing, change clothing immediately.
- Never overfill the fuel tank. Replace the fuel cap and tighten it securely.

## Operation

- The operator and passenger must use seat belts and remain seated whenever the machine is in motion. Keep both hands on the steering wheel, whenever possible, and the passenger should use the hand holds provided. Keep your arms and legs within the vehicle body at all times. Never carry passengers in the box or on attachments. Remember, your passenger may not be expecting you to brake or turn, and may not be ready.
- Do not overload your machine. The name plate (located under the middle of the dash) shows the load limits for the machine. Never overfill attachments or exceed the machine maximum gross vehicle weight (GVW).
- When starting the engine:
  - Sit on the operator’s seat and ensure that the parking brake is engaged.
  - Disengage the PTO (if so equipped) and return the hand-throttle lever to the OFF position (if equipped).
  - Make sure that the hydraulic-lift lever is in the center position.
  - Move the shift lever to the NEUTRAL position and press the clutch pedal.
  - Keep your foot off the accelerator pedal.
  - Turn ignition switch to the ON position. When the glow-plug indicator goes off, the engine is ready to start.
  - Turn the ignition key to the START position.
- Failure to operate machine safely may result in an accident, tipping over the machine, and/or serious injury or death. To prevent tipping or loss of control, take the following precautions:
  - Use extreme caution, reduce your speed, and maintain a safe distance around sand traps, ditches, creeks, ramps, any unfamiliar areas, or other hazards.
  - Watch for holes or other hidden hazards.
  - Use caution when operating the machine on a steep slope. Normally, travel straight up and down slopes. Reduce your speed when making sharp turns or when turning on hillsides. Avoid turning on hillsides whenever possible.
  - Use extra caution when operating the vehicle on wet surfaces, at higher speeds, or with a full load. Stopping time will increase with a full load. Shift into a lower gear before starting up or down a hill.
  - When loading the bed, distribute the load evenly. Use extra caution if the load exceeds the dimensions of the machine/bed. Operate the vehicle with extra caution when handling off-center loads that cannot be centered. Keep loads balanced and secure to prevent them from shifting.
- Avoid sudden stops and starts. Do not go from reverse to forward or forward to reverse without first coming to a complete stop.
- Do not attempt sharp turns or abrupt maneuvers or other unsafe driving actions that may cause a loss of machine control.
- When dumping, do not let anyone stand behind the machine, and do not dump the load on anyone’s feet. Release the tailgate latches from the side of box, not from behind.
- Keep all bystanders away. Before backing up, look to the rear and ensure that no one is behind the machine. Back up slowly.
- Watch out for traffic when near or crossing roads. Always yield the right of way to pedestrians and other machines. This machine is not designed for use on streets or highways. Always signal your turns or stop early enough so other persons know what you plan to do. Obey all traffic rules and regulations.
- Never operate the machine in or near an area where there is dust or fumes in the air which are explosive. The electrical and exhaust systems of the machine can produce sparks capable of igniting explosive materials.
- Always watch out for and avoid low overhangs such as tree limbs, door jambs, overhead walkways, etc. Make sure that there is enough room overhead to easily clear the machine and your head.
- If you are ever unsure about safe operation, **stop work**, and ask your supervisor.
- Do not touch the engine, transaxle, radiator, muffler, or muffler manifold while the engine is running or soon after it has stopped, because these areas may be hot enough to cause burns.
- If the machine ever vibrates abnormally, stop immediately, shut the engine off, wait for all motion to stop, and inspect for damage. Repair all damage before resuming operation.
- Before getting off the seat:
  1. Stop the machine.
  2. Set the parking brake.
  3. Turn the ignition key to the OFF position.
  4. Remove the ignition key.

**Note:** If the machine is on an incline, block the wheels after getting off the machine.
- Lightning can cause severe injury or death. If lightning is seen or thunder is heard in the area, do not operate the machine; seek shelter.

## Braking

- Slow down the machine before you approach an obstacle. This gives you extra time to stop or turn away. Hitting an obstacle can injure you and your passenger. In addition, it can damage the machine and its contents.
- Gross Vehicle Weight (GVW) has a major impact on your ability to stop and/or turn. Heavy loads and attachments make the machine harder to stop or turn. The heavier the load, the longer it takes to stop.
- Decrease the speed of the machine if the cargo box has been removed and there is no attachment installed on the machine. The braking characteristics change and fast stops may cause the rear wheels to lock up, which will affect the control of the machine.
- Turf and pavement are much more slippery when they are wet. It can take 2 to 4 times longer to stop the machine on wet surfaces as on dry surfaces. If you drive through deep-standing water and get the brakes wet, they will not work well until they are dry. After driving through water, you should test the brakes to make sure that they work properly. If they do not, drive slowly on a level ground while putting light pressure on the brake pedal. This will dry out the brakes.

## Operating on Hills

### **⚠ WARNING**

Operating the machine on a hill may cause tipping or rolling of the machine, or the engine may stall and you could lose headway on the hill. This could result in personal injury.

- Do not operate the machine on excessively steep slopes.
- Do not accelerate quickly or slam the brakes when backing down a hill, especially with a load.
- If the engine stalls or you lose headway on a hill, slowly back straight down the hill. Never attempt to turn the machine around.
- Operate the machine slowly on a hill and use caution.
- Avoid turning on a hill.
- Reduce your load and the speed of the machine.
- Avoid stopping on hills, especially with a load.

Take these precautions when operating the machine on a hill:

- Slow the machine down before starting up or down a hill.
- If the engine stalls or you begin to lose momentum while climbing a hill, gradually apply the brakes and slowly back the machine straight down the hill.
- Turning while traveling up or down hills can be dangerous. If you have to turn while on a hill, do it slowly and cautiously. Never make sharp or fast turns.

- Heavy loads affect stability. Reduce the weight of the load and your ground speed when operating on hills or if the load has a high center of gravity. Secure the load to the cargo box of the machine to prevent the load from shifting. Take extra care when hauling loads that shift easily (liquid, rock, sand, etc.).
- Avoid stopping on hills, especially with a load. Stopping while going down a hill will take longer than stopping on level ground. If you must stop the machine, avoid sudden speed changes, which may initiate tipping or rolling of the machine. Do not slam on the brakes when rolling backward, as this may cause the machine to overturn.
- We strongly recommend installing the optional ROPS kit before riding on hilly terrain.

## Operating on Rough Terrain

Reduce the ground speed of the machine and load carried in the machine when operating on rough terrain, uneven ground, and near curbs, holes, and other sudden changes in terrain. Loads may shift, causing the machine to become unstable.

### **⚠ WARNING**

Sudden changes in terrain may cause abrupt steering wheel movement, possibly resulting in hand and arm injuries.

- Reduce your speed when operating on rough terrain and near curbs.
- Grip the steering wheel loosely around the perimeter keeping thumbs up and out of the way of the steering wheel spokes.

## Loading and Dumping

The weight and position of cargo and passenger can affect the stability and handling of the machine. Be aware of the following condition to avoid losing control of the machine or tipping it over:

- Do not exceed the rated weight capacity of the machine when operating it with a load in the cargo box, when towing a trailer, or both; refer to [Specifications \(page 18\)](#).
- Use caution when operating the machine on a hillside or on rough terrain, particularly with a load in the cargo box or when towing a trailer or both.
- Be aware that the stability and control of the machine are reduced when the load in the cargo box is poorly distributed.
- Carrying oversized loads in the cargo box changes the stability of the machine.
- The steering, braking, and stability of the machine are affected when carrying a load where the weight of the material cannot be bound to the machine, such as the liquid in a large tank.

## **▲ WARNING**

**The weight of the box may be heavy. Hands or other body parts could be crushed.**

- **Keep hands and other body parts clear when lowering the box.**
- **Do not dump materials on bystanders.**
- Never dump a loaded cargo box while the machine is sideways on a hill. The change in weight distribution may cause the machine to overturn.
- When operating with a heavy load in the cargo box, reduce your speed and allow for sufficient braking distance. Do not suddenly apply the brakes. Use extra caution on slopes.
- Be aware that heavy loads increase your stopping distance and reduce your ability to turn quickly without tipping over.
- The rear cargo space is intended for load carrying purposes only, not for passengers.
- Never overload your machine. The name plate (located under the middle of the dash) shows the load limits for the machine. Never overfill attachments or exceed the machine maximum gross vehicle weight (GVW).

## **Maintenance**

- Before servicing or making adjustments to the machine, shut off the engine, set the parking brake, and remove the key from the ignition to prevent accidental starting of the engine.
- Never work under a raised bed without placing the bed safety support on the fully extended cylinder rod.
- Make sure that all hydraulic-line connectors are tight, and that all hydraulic hoses and lines are in good condition before applying pressure to the system.
- Before disconnecting or performing any work on the hydraulic system, all pressure in the system must be relieved by stopping the engine, cycling the dump valve from raise to lower and/or lowering box and attachments. Place the remote hydraulics lever in the float position. If the box must be in raised position, secure it with the safety support.
- To make sure that the entire machine is in good condition, keep all nuts, bolts, and screws properly tightened.
- To reduce the potential fire hazard, keep the engine area free of excessive grease, grass, leaves, and accumulation of dirt.
- If the engine must be running to perform a maintenance adjustment, keep hands, feet, clothing, and any parts of the body away from the engine and any moving parts. Keep everyone away.
- Do not overspeed the engine by changing the governor settings. The maximum engine speed is 3,650 rpm. To

ensure safety and accuracy, have an Authorized Toro Distributor check the maximum engine speed with a tachometer.

- If major repairs are ever needed or assistance is required, contact an Authorized Toro Distributor.
- To be sure of optimum performance and safety, always purchase genuine Toro replacement parts and accessories. Replacement parts and accessories made by other manufacturers could be dangerous. Altering this vehicle in any manner may affect the operation of the vehicle, performance, durability or its use may result in injury or death. Such use could void the product warranty of The Toro® Company.

## **Sound Pressure**

This unit has a sound pressure level at the operator's ear of 82 dBA, which includes an Uncertainty Value (K) of 1 dBA.

The sound pressure level was determined according to the procedures outlined in EN ISO 11201.

## **Vibration**

### **Hand-Arm**

- Measured vibration level for right hand =  $0.41 \text{ m/s}^2$
- Measured vibration level for left hand =  $0.2 \text{ m/s}^2$
- Uncertainty Value (K) =  $0.5 \text{ m/s}^2$

Measured values were determined according to the procedures outlined in EN 1032.

### **Whole Body**

- Measured vibration level =  $0.3 \text{ m/s}^2$
- Uncertainty Value (K) =  $0.5 \text{ m/s}^2$

Measured values were determined according to the procedures outlined in EN 1032.

# Safety and Instructional Decals



Safety decals and instructions are easily visible to the operator and are located near any area of potential danger. Replace any decal that is damaged or lost.

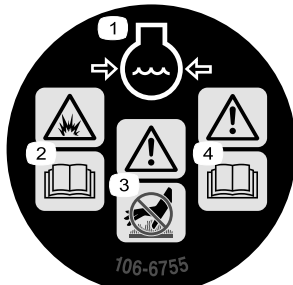

**106-6755**

1. Engine coolant under pressure.
2. Explosion hazard—read the *Operator's Manual*.
3. Warning—do not touch the hot surface.
4. Warning—read the *Operator's Manual*.

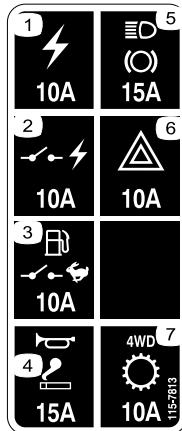

**115-7813**

1. Power outlet—10A
2. Switched power—10A
3. Fuel pump, supervisor switch—10A
4. Horn, power point—15A
5. Lights, brake—15A
6. Hazard—10A
7. 4WD, Transmission—10A

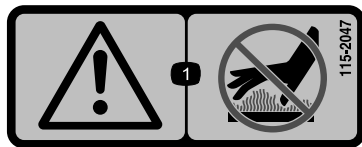

**115-2047**

1. Warning—do not touch the hot surface.

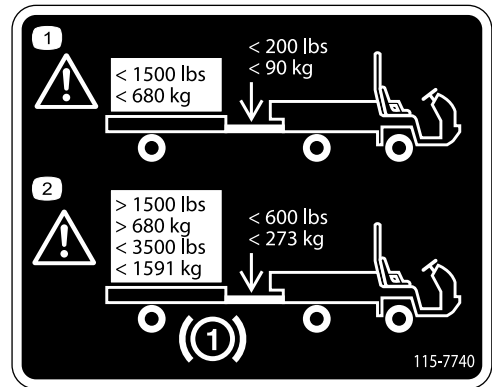

**115-7740**

1. Warning—maximum trailer weight is 680 kg (1500 lb); maximum tongue weight is 90 kg (200 lb).
2. Warning—trailer brakes are required when towing greater than 680 kg (1500 lb); maximum trailer weight with trailer brakes is 1591 kg (3500 lb); maximum tongue weight with trailer brakes is 273 kg (600 lb).

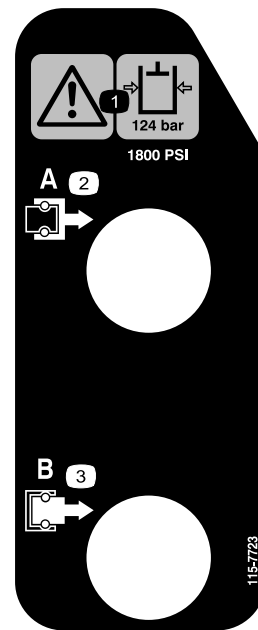

**115-7723**

1. Warning—the hydraulic oil pressure is 124 bar (1800 psi).
2. Coupler A
3. Coupler B



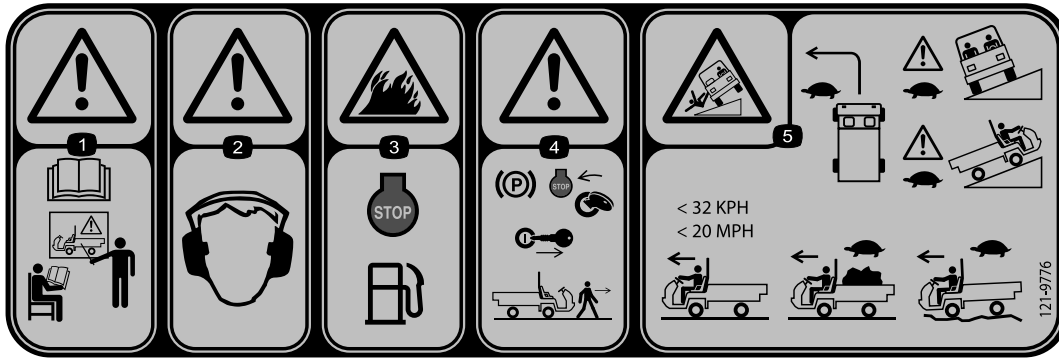

121-9776

1. Warning—read the *Operator's Manual* and receive proper training before operating the machine.
2. Warning—wear hearing protection.
3. Fire hazard—stop the engine before refueling the machine.
4. Warning—engage the parking brake, stop the engine, and remove the key from the ignition before walking away from the machine.
5. Tipping hazard—take turns slowly; drive slowly up and across cliffs; with no load, do not exceed 32 kph (20 mph); while carrying a load or when driving on uneven terrain, drive slowly.

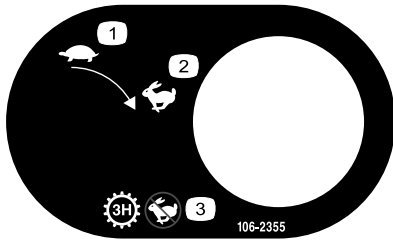

106-2355

1. Slow
2. Fast
3. Transmission—third high; no fast speed

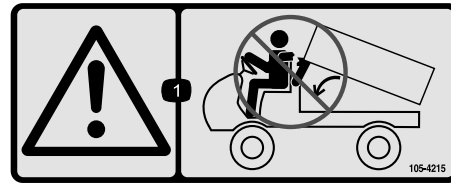

105-4215

1. Warning—avoid pinch points.

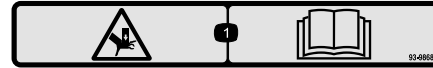

93-9868

1. Crushing hazard of hand—read the *Operator's Manual*.

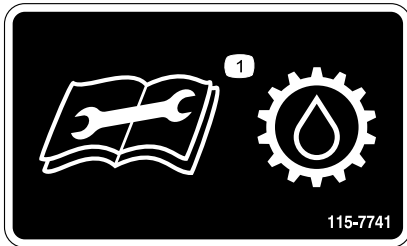

115-7741

1. Read the *Operator's Manual* before servicing transmission fluid.

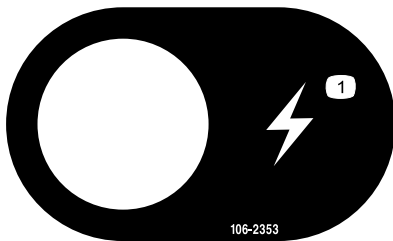

106-2353

1. Electrical power point



**Battery Symbols**

Some or all of these symbols are on your battery.

- |  |  |
|--|--|
| 1. Explosion hazard                    | 6. Keep bystanders a safe distance from the battery.                           |
| 2. No fire, open flame, or smoking.    | 7. Wear eye protection; explosive gases can cause blindness and other injuries |
| 3. Caustic liquid/chemical burn hazard | 8. Battery acid can cause blindness or severe burns.                           |
| 4. Wear eye protection.                | 9. Flush eyes immediately with water and get medical help fast.                |
| 5. Read the <i>Operator's Manual</i> . | 10. Contains lead; do not discard.   |

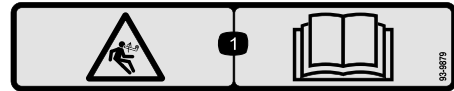

**93-9879**

1. Stored energy hazard—read the *Operator's Manual*.

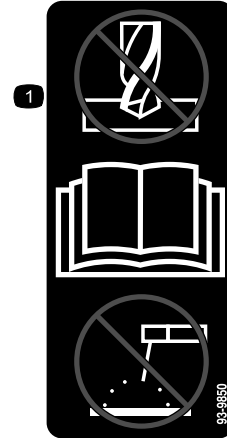

**93-9850**

1. Do not repair or revise—read the *Operator's Manual*.

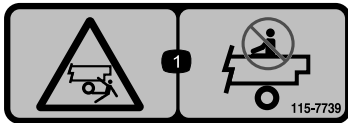

**115-7739**

1. Falling, crushing hazard, bystanders—no riders on machine.



**93-9899**

1. Crushing hazard—install the cylinder lock.



**115-7756**

1. High flow hydraulics—engaged



**106-7767**

1. Warning—read the *Operator's Manual*; avoid tipping the machine; wear the seat belt; lean away from the direction the machine is tipping.

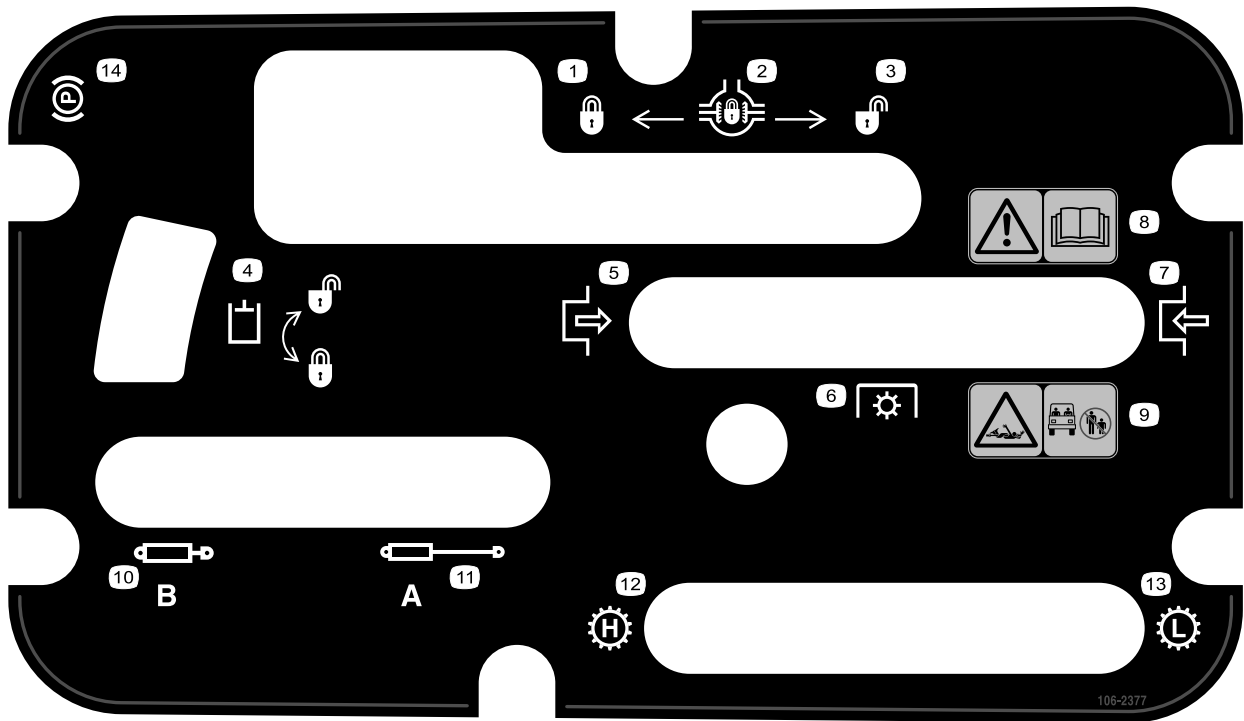

### 106-2377

- |                         |  |
|-------------------------|--|
| 1. Locked               | 8. Warning—read the <i>Operator's Manual</i> .                                   |
| 2. Differential lock    | 9. Entanglement hazard, shaft—keep bystander's a safe distance from the vehicle. |
| 3. Unlocked             | 10. Retract hydraulics   |
| 4. Hydraulic lock       | 11. Extend hydraulics  |
| 5. Engage               | 12. Transmission—high speed  |
| 6. Power take-off (PTO) | 13. Transmission—low speed   |
| 7. Disengage            | 14. Parking brake  |

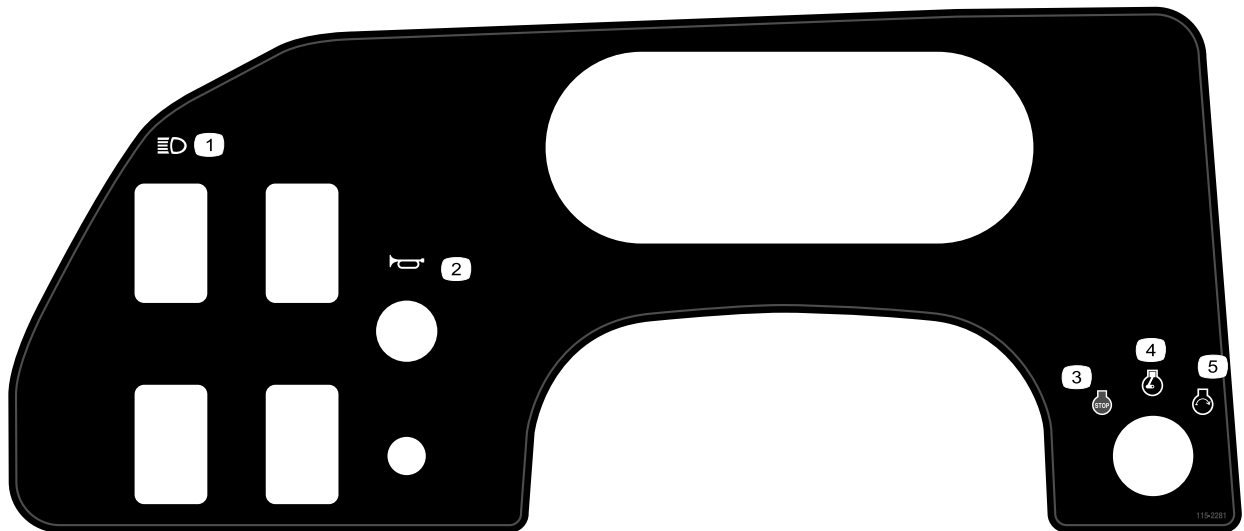

### 115-2281

- |                |                 |
|----------------|-----------------|
| 1. Headlights  | 4. Engine—run   |
| 2. Horn        | 5. Engine—start |
| 3. Engine—stop |                 |

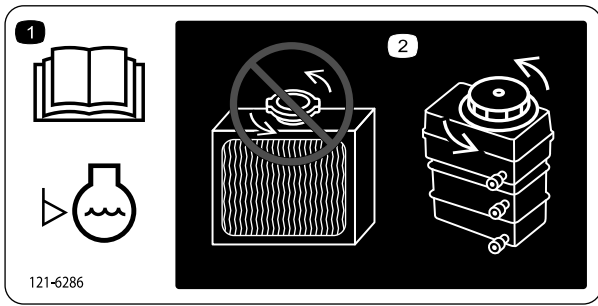

**121-6286**

1. The coolant level must be checked daily before use. Read the *Operator's Manual* before checking the engine coolant level.
2. Do not open or add coolant to the radiator; doing so will introduce air into the system and results in engine damage. Add only engine coolant to the reservoir.

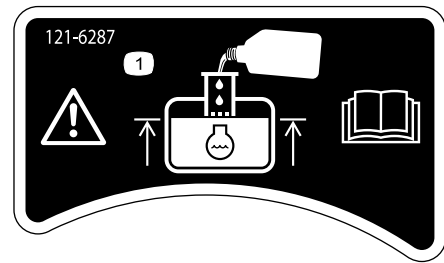

**121-6287**

1. Fill the reservoir with engine coolant to the bottom of the standpipe.



**93-9852**

1. Warning—read the *Operator's Manual*.
2. Crushing hazard—install the cylinder lock.

# Setup

## Loose Parts

Use the chart below to verify that all parts have been shipped.

Procedure	Description	Qty.	Use
<b>1</b>	Steering wheel	1	Install the steering wheel (TC models only).
<b>2</b>	ROPS frame Bolt (1/2 inch)	1 6	Mount the Rollover-Protection System (ROPS).
<b>3</b>	No parts required	–	Check the engine oil, the transaxle/hydraulic fluid, and the brake-fluid levels.

**Note:** Determine the left and right side of the machine from the normal operating position.



## Installing the Steering Wheel

### TC Models Only

#### Parts needed for this procedure:

1	Steering wheel
---	----------------

### Procedure

1. Release the tabs on the back of the steering wheel that hold the center cover in place, and remove the cover from the hub of the steering wheel.
2. Remove the locknut and washer from the steering shaft.
3. Slide the steering wheel and washer onto the shaft.

**Note:** Align the steering wheel on the shaft so that the cross beam is horizontal when the tires are pointed straight ahead and the thicker spoke of the steering wheel is downward.

**Note:** The dust cover is positioned onto the steering shaft at the factory.

4. Secure the steering wheel to the shaft with the locknut and torque the locknut to 24 to 29 N·m (18 to 22 ft-lb) as shown in [Figure 3](#).

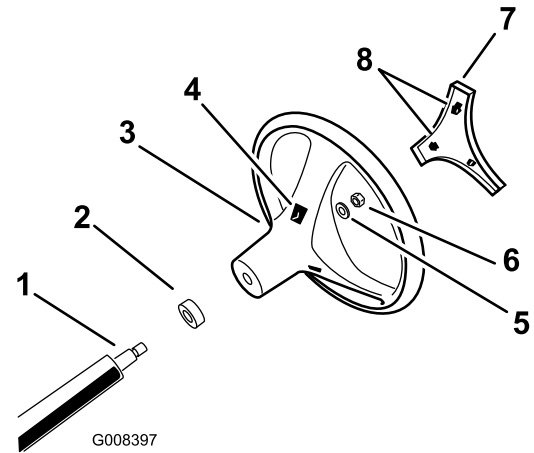

**Figure 3**

- |                       |                  |
|-----------------------|------------------|
| 1. Steering shaft     | 5. Washer        |
| 2. Dust cover         | 6. Locknut       |
| 3. Steering wheel     | 7. Cover         |
| 4. Tab slots in wheel | 8. Tabs in cover |
- 
5. Align the tabs of the cover with the slots in the steering wheel, and snap the cover onto the steering-wheel hub ([Figure 3](#)).

# 2

## Installing the Rollover-Protection System (ROPS)

Parts needed for this procedure:

1	ROPS frame
6	Bolt (1/2 inch)

### Procedure

1. Align each side of the ROPS with the mounting holes in the frame at each side of the vehicle as shown in [Figure 4](#).

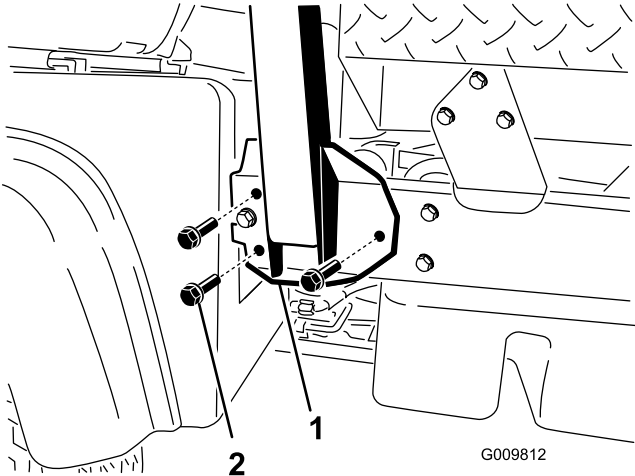

Figure 4

1. ROPS-mounting bracket
2. Flanged bolts (1/2 x 1-1/4 inches)

2. Secure each side of the ROPS to frame with 3 flanged bolts (1/2 x 1-1/4 inches) and tighten the bolts to 115 N·m (85 ft-lb).

# 3

## Checking the Fluid Levels

No Parts Required

### Procedure

1. Check the engine-oil level before and after the engine is first started; refer to [Checking the Engine-Oil Level \(page 20\)](#).
2. Check the transaxle/hydraulic-fluid level before the engine is first started; refer to [Checking the Transaxle/Hydraulic-Fluid Level \(page 23\)](#).
3. Check the brake-fluid level before the engine is first started; refer to [Checking the Brake-Fluid Level \(page 25\)](#).

# Product Overview

## Controls

**Note:** Determine the left and right sides of the machine from the normal operating position.

### Accelerator Pedal

The accelerator pedal (Figure 5) gives the operator the ability to vary the engine and ground speed of the machine when the transmission is in gear. Pressing the pedal increases the engine speed and ground speed. Releasing the pedal decreases the engine speed and ground speed of the machine.

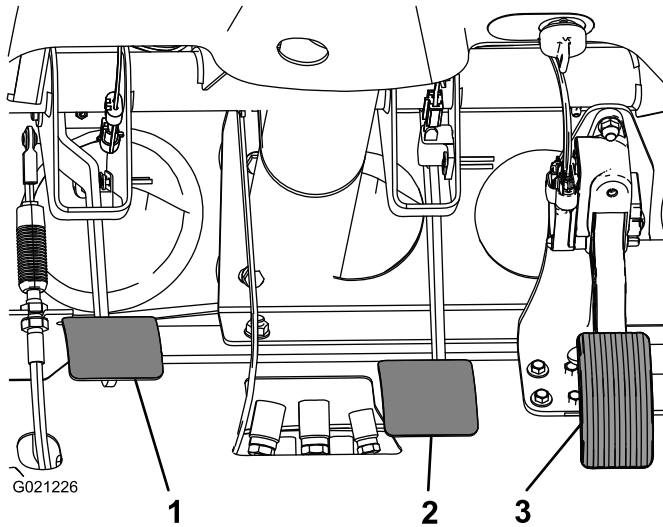

Figure 5

1. Clutch pedal
2. Brake pedal
3. Accelerator pedal

### Clutch Pedal

You must fully press the clutch pedal (Figure 5) to disengage the clutch when starting the engine or shifting transmission gears. Release the pedal smoothly when the transmission is in gear to prevent unnecessary wear on the transmission and other related parts.

**Important:** Do not ride the clutch pedal during operation. The clutch pedal must be fully out or the clutch will slip, causing heat and wear. Never hold the machine stopped on a hill using the clutch pedal. Damage to the clutch may occur.

### Brake Pedal

Use the brake pedal (Figure 5) to apply the service brakes to stop or slow the vehicle.

## ⚠ CAUTION

Worn or maladjusted brakes may result in personal injury.

If the brake pedal travels to within 3.8 cm (1-1/2 inches) of the vehicle floor board, the brakes must be adjusted or repaired.

### Gear-Shift Lever

Fully press the clutch pedal and move the shift lever (Figure 6) into the desired gear selection. A diagram of the shift pattern is shown below.

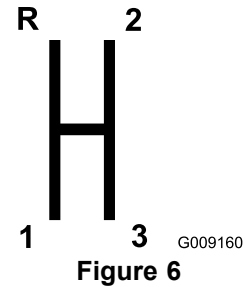

Figure 6

**Important:** Do not shift the transaxle to the reverse or forward gear unless the vehicle is standing still. Damage to the transaxle may occur.

## ⚠ CAUTION

Down shifting from too high a speed can cause the rear wheels to skid, resulting in loss of machine control as well as clutch and/or transmission damage.

Shift smoothly to avoid grinding gears.

### Differential Lock

The differential lock allows the rear axle to lock for increased traction. You can engage the differential lock when the machine is in motion (Figure 7). Move the lever forward and to the right to engage the lock.

**Note:** Machine motion plus a slight turn is required to engage or disengage the differential lock.

## ⚠ CAUTION

Turning with the differential lock on can result in loss of machine control.

Do not operate the machine with the differential lock on when making sharp turns or at high speeds; refer to [Using the Differential Lock \(page 29\)](#).

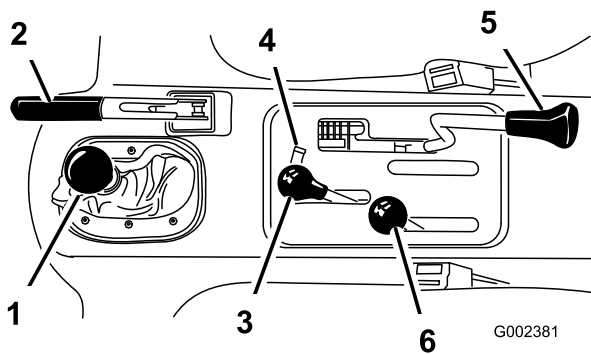

**Figure 7**

- |                       |                           |
|-----------------------|---------------------------|
| 1. Gear-shift lever   | 4. Hydraulic-lift lock    |
| 2. Parking brake      | 5. Differential lock      |
| 3. Hydraulic-bed lift | 6. High-low range shifter |

## Parking Brake

Whenever the engine is shut off, set the parking brake (Figure 7) in order to prevent the machine from accidentally moving.

- To set the parking brake, pull back on the lever.
- To release, push the lever forward.

**Note:** Release the parking brake before moving the machine.

If you park the machine on a steep grade, set the parking brake, shift the transmission into first gear on a uphill grade or reverse gear on a down hill grade, and place chocks at the downhill side of the wheels.

## Hydraulic Lift

The hydraulic lift raises and lowers the bed. Move it rearward to raise the bed, and forward to lower it (Figure 7).

**Important:** When lowering the bed, hold the lever in the forward position for 1 or 2 seconds after the bed contacts the frame to secure it in the lowered position. Do not hold the hydraulic lift in either the raise or lower position, for more than 5 seconds, once the cylinders have reached the end of their travel.

## Hydraulic-Lift Lock

The hydraulic-lift lock locks the lift lever, so the hydraulic cylinders do not operate when the machine is not equipped with a bed (Figure 7). It also locks the lift lever in the ON position when using the hydraulics for attachments.

## High-Low Range Shifter

The high-low range shifter adds 3 additional speeds for precise speed control (Figure 7):

- The machine must be completely stopped before shifting between the HIGH and LOW range.

- Shift only on level ground.
- Press the clutch pedal fully.
- Move the lever fully forward for HIGH and fully rearward for LOW.

High is for higher speed driving on level, dry surfaces with light loads.

Low is for low-speed driving. Use this range when greater than normal power or control is required. For example, steep grades, difficult terrain, heavy loads, slow speed but high-engine speed (spraying).

**Important:** There is a location between HIGH and LOW in which the transaxle is in neither range. Do not use this position as a NEUTRAL position because the vehicle could move unexpectedly if the High-Low shifter is bumped and the gear-shift lever is in gear.

## Ignition Switch

Use the ignition switch (Figure 8) to start and shut off the engine. It has 3 positions: OFF, ON, and START. Rotate the key clockwise to the START position to engage the starter motor. Release the key when the engine starts. The key moves automatically to the ON position. To shut off the engine, rotate the key counterclockwise to the OFF position.

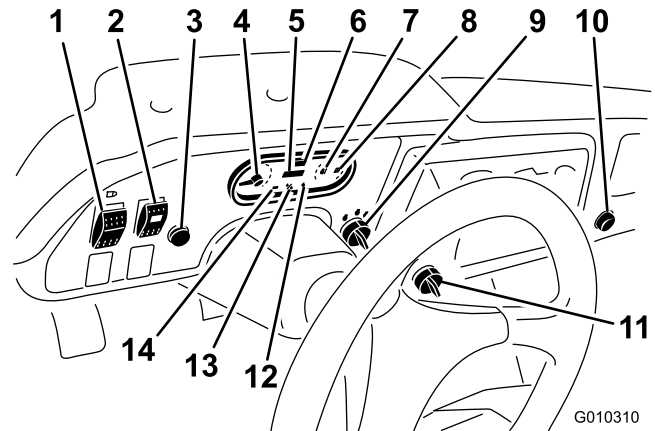

**Figure 8**

- |   |                                      |
|---|--------------------------------------|
| 1. Light switch                                 | 8. Fuel gauge                        |
| 2. High-flow-hydraulics switch (TC models only) | 9. Ignition switch                   |
| 3. Horn (TC models only)                        | 10. Power point                      |
| 4. Tachometer                                   | 11. Supervisor switch                |
| 5. Hour meter                                   | 12. Oil-pressure-warning light       |
| 6. Speedometer                                  | 13. Glow-plug indicator              |
| 7. Coolant-temperature gauge and light          | 14. Charge indicator gauge and light |



## Hour Meter

The hour meter indicates the total hours of machine operation. The hour meter (Figure 8) starts to function whenever the key switch is rotated to the ON position or if the engine is running.

## Speed-Limiter Switch

Move the speed-limiter switch (Figure 8) to the SLOW position and remove the key. The switch limits the engine to 2,200 rpm when the machine is in third gear in the High range, which limits the top speed to 21 km/h (13 mph).

## Light Switch

Push the light switch (Figure 8) to toggle the headlights on or off.

## Oil-Pressure-Warning Light

The oil-pressure-warning light glows (Figure 8) if the engine-oil pressure drops below a safe level while the engine is running. If the light flickers or remains on, stop the vehicle, shut off the engine, and check the oil level. If the oil level is low, but adding oil does not cause the light to go out when the engine is started, shut off the engine immediately and contact your local Toro distributor for assistance.

Check the operation of warning lights as follows:

1. Apply the parking brake.
2. Turn the ignition key to the ON/PREHEAT position, but do not start the engine.

**Note:** The oil-pressure light should glow red. If the light does not function, either a bulb is burned out or there is a malfunction in the system which must be repaired.

**Note:** If engine was just turned off, it may take 1 to 2 minutes for the light to come on.

## Glow-Plug Indicator

The glow-plug indicator (Figure 8) glows red when the glow plugs are activated.

**Important:** The glow-plug indicator will turn on, for an additional 15 seconds, when the switch returns to the START position.

## Coolant-Temperature Gauge and Light

Registers the coolant temperature in the engine. Operates only when the ignition switch is in ON position (Figure 8). The indicator light illuminates blinking red if the engine overheats.

## Charge Indicator

Illuminates when the battery is being discharged. If the light illuminates during operation, stop the machine, turn off the

engine, and check for possible causes, such as the alternator belt (Figure 8).

**Important:** If the alternator belt is loose or broken, do not operate the machine until adjustment or repair is complete. Failure to observe this precaution may result in damage to the engine.

Check the operation of the warning lights as follows:

- Apply the parking brake.
- Turn the ignition key to the ON/PREHEAT position, but do not start the engine. The coolant temperature, charge indicator, and oil-pressure lights should glow. If any light does not function, either a bulb is burned out or there is a malfunction in the system which must be repaired.

## Fuel Gauge

The fuel gauge shows the amount of fuel in the tank. It operates only when ignition switch is in the ON position (Figure 8). Red indicates low fuel level and blinking red indicates near empty.

## High-Flow-Hydraulics Switch

### TC Models Only

Turn on the switch to activate the high-flow hydraulics (Figure 8).

## Horn Button

### TC Models Only

Pressing the horn button activates the horn (Figure 8).

## Tachometer

Registers the speed of the engine (Figure 8 and Figure 9). The white triangle indicates 540 rpm for PTO operation (Figure 9).

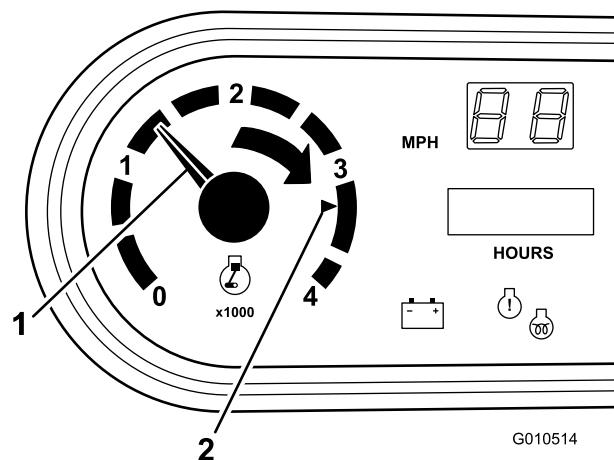

Figure 9

1. Speed of the engine
2. 3,300 rpm for 540 rpm PTO operation

## Speedometer

Registers the ground speed of the machine (Figure 8). The speedometer is in mph but can easily be converted to km/h; refer to [Converting the Speedometer](#) (page 52).

## Power Point

Use the power point (Figure 8) to power optional 12 V electrical accessories.

## Passenger Hand Hold

The passenger hand hold is located on the dashboard (Figure 10).

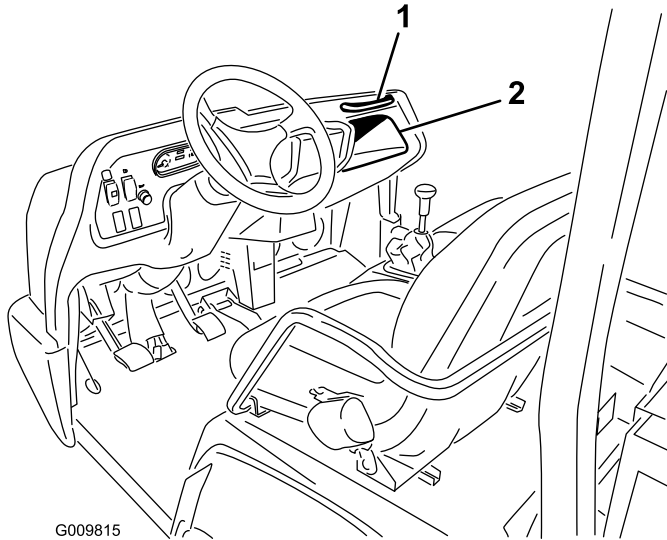
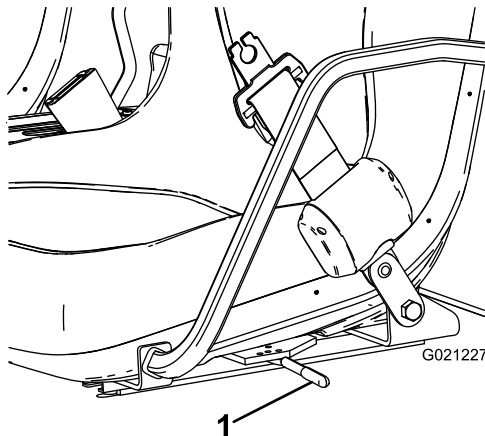

**Figure 10**

1. Passenger hand hold      2. Storage compartment

## Seat-Adjustment Lever

The seats can be adjusted forward and rearward for your comfort (Figure 11).



**Figure 11**

1. Seat-adjustment lever

## Specifications

**Note:** Specifications and design are subject to change without notice.

### Dimensions

Overall Width	160 cm (63 inches)
Overall Length	Without bed: 326 cm (128 inches) With full bed: 331 cm (130 inches) With 2/3 bed in rear-mounting location: 346 cm (136 inches)
Base Weight (Dry)	Model 07385—887 kg (1,956 lb) Model 07385H—887 kg (1,956 lb) Model 07385TC—924kg (2,037 lb) Model 07387—914 kg (2,015 lb) Model 07387H—914 kg (2,015 lb) Model 07387TC—951 kg (2,096 lb)
Rated Capacity (includes 91 kg (200 lb) operator, 91 kg (200 lb) passenger and loaded attachment)	Model 07385—1,471 kg (3,244 lb) Model 07385TC—1,435 kg (3,163 lb) Model 07387—1,445 kg (3,185 lb) Model 07387TC—1,408 kg (3,104 lb)
Maximum Gross Vehicle Weight	2,359 kg (5,200 lb)
Tow Capacity	Tongue weight: 272 kg (600 lb) Maximum trailer weight: 1,587 kg (3,500 lb)
Ground Clearance	18 cm (7 inches) with no load
Wheel Base	118 cm (70 inches)
Wheel Tread (center line to center line)	Front: 117 cm (46 inches) Rear: 121 cm (48 inches)
Height	191 cm (75 inches) to top of ROPS

### Attachments/Accessories

A selection of Toro approved attachments and accessories is available for use with the machine to enhance and expand its capabilities. Contact your Authorized Service Dealer or Distributor or go to [www.Toro.com](http://www.Toro.com) for a list of all approved attachments and accessories.

# Operation

**Note:** Determine the left and right sides of the machine from the normal operating position.

## ⚠ CAUTION

A raised bed full of material without the proper safety support rod may lower unexpectedly. Working under an unsupported raised bed may cause injury to you or others.

- Before servicing or making adjustments to the machine, shut off the engine, set the parking brake, and remove the key from the ignition switch.
- Remove any load material from the bed or other attachment and insert the safety support on a fully extended cylinder rod before working under a raised bed.

## Operating the Cargo Box

**Note:** If possible, center loads in the cargo box.

**Note:** Remove all cargo from the box before lifting the box up to service the machine.

## Raising the Cargo Box

### ⚠ WARNING

Driving the machine with the cargo box raised may cause the machine to tip or roll easier. The box structure may become damaged if you operate the machine with the box raised.

- Only operate the machine when the cargo box is down.
- After emptying the cargo box, lower it.

### ⚠ CAUTION

If a load is concentrated near the back of the cargo box when you release the latches, the box may unexpectedly tip open injuring you or bystanders.

- Center loads in the cargo box if possible.
- Hold the cargo box down and ensure that no one is leaning over the box or standing behind it when releasing the latches.
- Remove all cargo from the box before lifting the box up to service the machine.

Move the lever rearward to raise the cargo box (Figure 12).

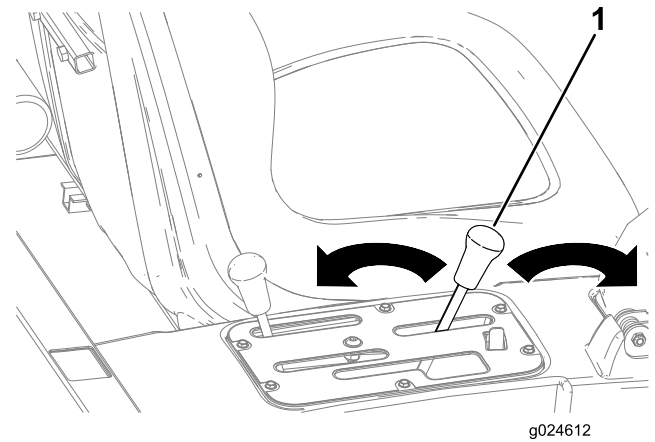

Figure 12

1. Cargo-box lever

## Lowering the Box

### ⚠ WARNING

The weight of the box may be heavy. Hands or other body parts could be crushed.

Keep hands and other body parts clear when lowering the box.

Move the lever forward to lower the cargo box (Figure 12).

## Opening the Tailgate

1. Ensure that the cargo box is lowered completely.
2. Open the latches on the left and right side of the cargo box and lower the tailgate (Figure 13).

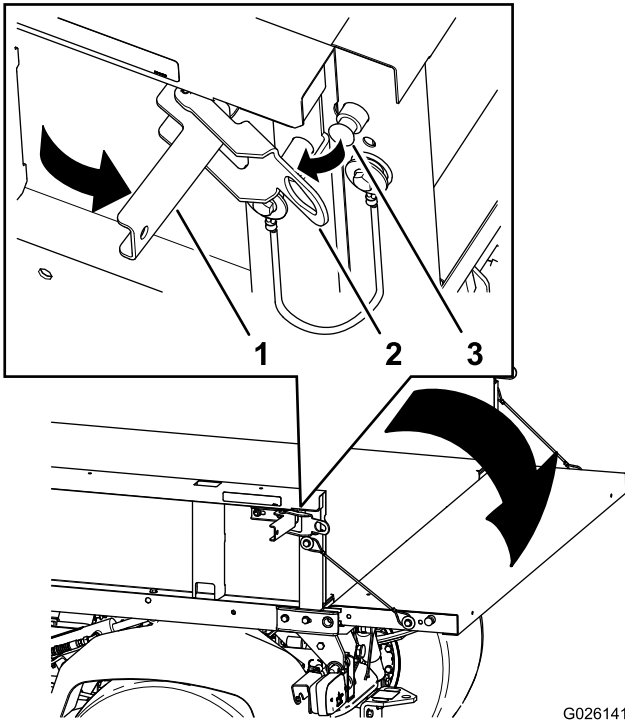

Figure 13

G026141

- 1. Latch handle
- 2. Latch gate
- 3. Latch pin

or below the Add mark on the dipstick, add oil to bring the oil level to the Full mark. **Do not overfill the engine with oil.** If the oil level is between the Full and Add marks, no additional oil is required.

1. Position the machine on a level surface.
2. Remove the dipstick and wipe it with a clean rag (Figure 15).

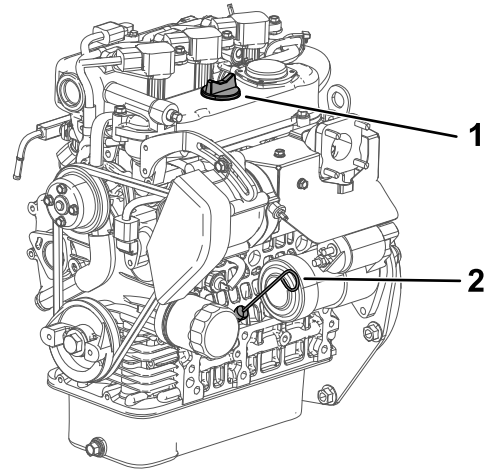

Figure 15

g028637

1. Filler cap
2. Dipstick

## Checking the Engine-Oil Level

**Service Interval:** Before each use or daily

**Engine-oil type:** Detergent engine oil API SJ or higher

**Engine-oil viscosity:** 10W-30; Choose an engine-oil viscosity according to the ambient-air temperature to the table in Figure 14.

### USE THESE SAE VISCOSITY OILS

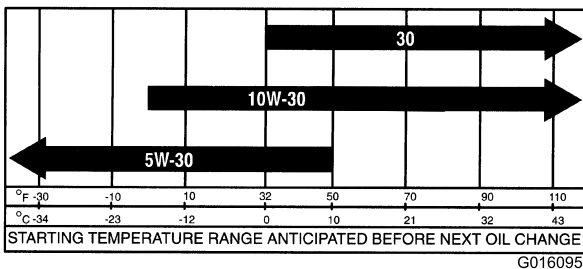

Figure 14

3. Insert the dipstick into the tube and make sure that it is seated fully (Figure 15).
4. Remove dipstick and check the level of the oil (Figure 15).
5. If the oil level is low, remove the filler cap (Figure 15), and add enough oil to raise the level to the Full mark on the dipstick.

**Note:** When adding oil, remove dipstick to allow proper venting. Pour the oil slowly and check the level often during this process. **Do not overfill the engine with oil.**

**Important:** When adding engine oil or filling oil, there must be clearance between the oil fill device and the oil fill hole in the valve cover as shown in Figure 16. This clearance is necessary to permit venting when filling, which prevents oil from overrunning into the breather.

The engine is shipped with oil in the crankcase; however, you should check the oil level before and after the engine is first started.

**Note:** The best time to check the engine oil is when the engine is cool before it has been started for the day. If it has already ran, allow the oil to drain back down to the sump for at least 10 minutes before checking. If the oil level is at

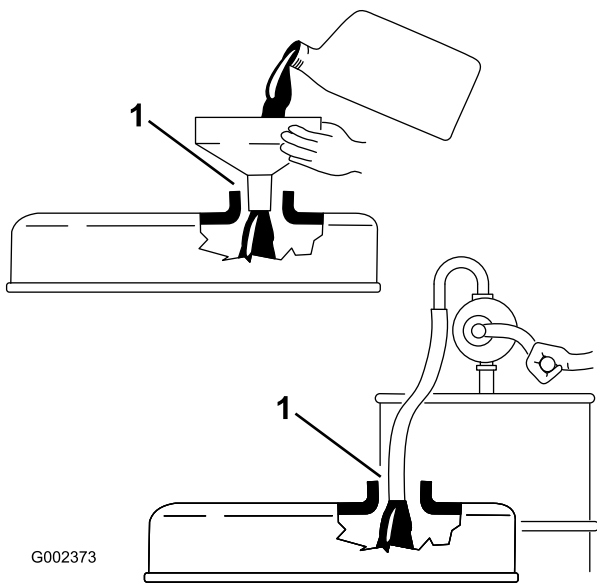

Figure 16

1. Note clearance

6. Install the dipstick firmly in place (Figure 15).

## Adding Fuel

**Fuel-tank capacity:** 22 L (5.85 US gallons).

Use only clean, fresh diesel fuel or biodiesel fuels with low (<500 ppm) or ultra-low (<15 ppm) sulfur content. The minimum cetane rating should be 40. Purchase fuel in quantities that can be used within 180 days to ensure fuel freshness.

- Use summer grade diesel fuel (No. 2-D) at temperatures above  $-7^{\circ}\text{C}$  ( $20^{\circ}\text{F}$ ) and winter grade (No. 1-D or No. 1-D/2-D blend) below that temperature.
- Use of winter grade fuel at lower temperatures provides lower flash point and cold flow characteristics which will ease starting and reduce fuel filter plugging.

**Note:** Use of summer grade fuel above  $-7^{\circ}\text{C}$  ( $20^{\circ}\text{F}$ ) will contribute toward longer fuel pump life and increased power compared to winter grade fuel.

**Important:** Do not use kerosene or gasoline instead of diesel fuel. Failure to observe this caution will damage the engine.

### ⚠ WARNING

Fuel is harmful or fatal if swallowed. Long-term exposure to vapors can cause serious injury and illness.

- Avoid prolonged breathing of vapors.
- Keep your face away from the nozzle and gas tank or conditioner opening.
- Keep fuel away from your eyes and skin.

### ⚠ DANGER

Under certain conditions, diesel fuel and fuel vapors are highly flammable and explosive. A fire or explosion from fuel can burn you and others and can cause property damage.

- Before removing the fuel tank cap, make sure that the vehicle is positioned on a level surface. Open fuel tank cap slowly.
- Use a funnel and fill the fuel tank outdoors, in an open area, when the engine is off and is cold. Wipe up any fuel that spills.
- Do not fill the fuel tank completely full. Add fuel to the fuel tank until the level is 25 mm (1 inch) below the bottom of the filler neck. This empty space in the tank allows the fuel to expand.
- Never smoke when handling fuel, and stay away from an open flame or where fuel fumes may be ignited by a spark.
- Store fuel in a clean, safety-approved container and keep the cap in place.

## Using Biodiesel Fuel

This machine can also use a biodiesel blended fuel of up to B20 (20% biodiesel, 80% petrodiesel). The petrodiesel portion should be low or ultra low sulfur. Observe the following precautions:

- The biodiesel portion of the fuel must meet specification ASTM D6751 or EN14214.
  - The blended fuel composition should meet ASTM D975 or EN590.
  - Painted surfaces may be damaged by biodiesel blends.
  - Use B5 (biodiesel content of 5%) or lesser blends in cold weather.
  - Monitor seals, hoses, gaskets in contact with fuel as they may be degraded over time.
  - Fuel filter plugging may be expected for a time after converting to biodiesel blends.
  - Contact your distributor if you wish for more information on biodiesel.
1. Clean the area around the fuel-tank cap.
  2. Remove the fuel-tank cap (Figure 17).

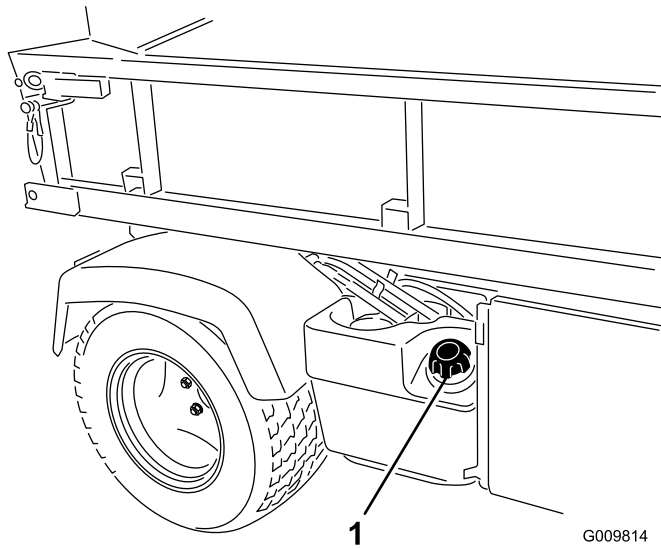

Figure 17

1. Fuel-tank cap

3. Fill the tank slightly below the top of the tank, (bottom of the filler neck), then install the cap.

**Note:** Do not overfill the fuel tank with fuel.

4. Wipe up any fuel that may have spilled to prevent a fire hazard.

## Checking the Coolant Level

**Service Interval:** Before each use or daily

**Cooling system capacity:** 3.7 L (4 US qt)

**Coolant type:** a 50/50 solution of water and permanent ethylene-glycol antifreeze.

### ⚠ CAUTION

If the engine has been running, the pressurized, hot coolant can escape and cause burns.

- Do not open the radiator cap.
- Allow the engine to cool at least 15 minutes or until the reserve tank is cool enough to touch without burning your hand.
- Use a rag when opening the reserve-tank cap, and open the cap slowly to allow steam to escape.
- Do not check the coolant level at the radiator; only check the coolant level at the reserve tank.

1. Park the machine on a level surface.
2. Check the coolant level inside the reserve tank (Figure 18).

**Note:** The coolant should be up to the bottom of the filler neck when the engine is cold.

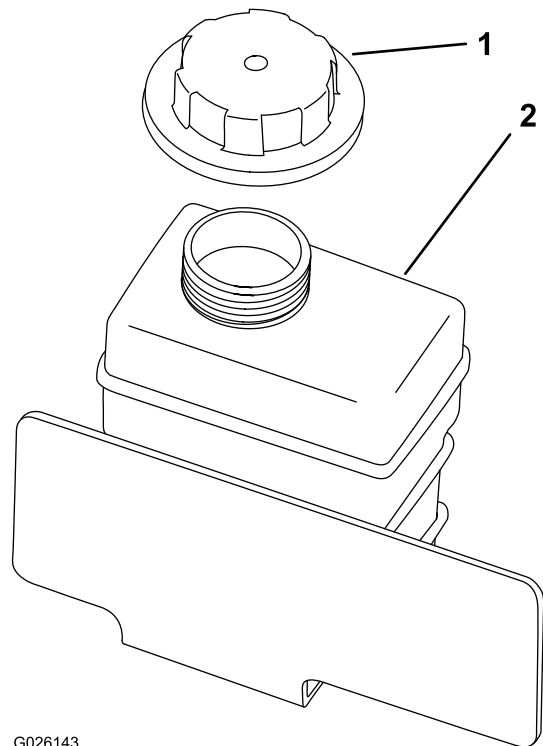

Figure 18

1. Reserve-tank cap
2. Reserve tank

- If the coolant is low, remove the reserve tank cap and add a 50/50 mixture of water and permanent ethylene-glycol antifreeze.

**Note:** Do not overfill the reserve tank with coolant.

- Install the reserve-tank cap.

## Checking the Transaxle/Hydraulic-Fluid Level

**Service Interval:** Before each use or daily (check the fluid level before the engine is first started and every 8 hours or daily, thereafter.)

**Transaxle fluid type:** Dexron III ATF

- Position the machine on a level surface.
- Clean the area around the dipstick (Figure 19).

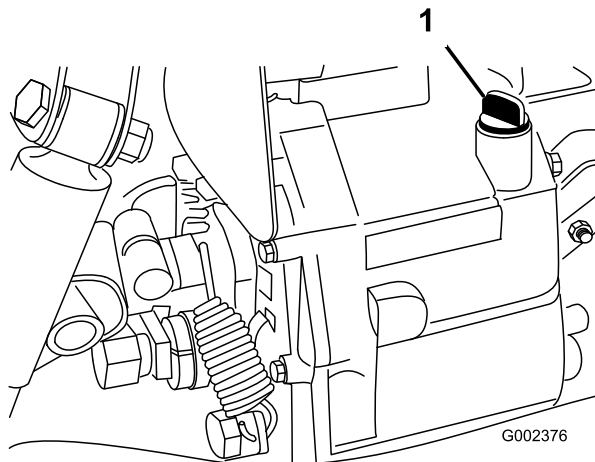

**Figure 19**

- Dipstick
- 
- Unscrew the dipstick from the top of the transaxle and wipe it with a clean rag.
  - Screw the dipstick into the transaxle and ensure that it is fully seated.
  - Unscrew the dipstick and check the fluid level.
- Note:** The fluid should be up to top of the flat portion of the dipstick.
- If the level is low, add enough of the specified fluid to achieve the proper level.

## Checking the High Flow Hydraulic-Fluid Level

### TC Models Only

**Service Interval:** Before each use or daily (check the level of hydraulic fluid before the engine is first started, and daily thereafter).

**Hydraulic-fluid type:** Toro Premium All Season Hydraulic Fluid (Available in 5-gallon pails or 55-gallon drums. See parts catalog or Toro distributor for part numbers.)

**Alternate fluids:** If the Toro fluid is not available, another conventional petroleum-based fluid may be used provided it meets the following material properties and industry specifications. Consult with your lubricant distributor to identify a satisfactory product.

**Note:** Toro will not assume responsibility for damage caused by improper substitutions, so use only products from reputable manufacturers who will stand behind their recommendation.

**High Viscosity Index/Low Pour Point Antiwear Hydraulic Fluid, ISO VG 46**

#### Material Properties:

- Viscosity—ASTM D445 cSt @ 40°C: 44 to 48/cSt @ 100°C: 7.9 to 8.5
- Viscosity Index, ASTM D2270—140 to 152
- Pour Point, ASTM D97— -35°F to -46°F
- FZG, Fail stage—11 or better
- Water content (new fluid)—500 ppm (maximum)

#### Industry Specifications:

Vickers I-286-S, Vickers M-2950-S, Denison HF-0, Vickers 35 VQ 25 (Eaton ATS373-C)

- Clean the area around the filler neck and the cap of the hydraulic tank (Figure 20).
- Remove the cap from the filler neck.

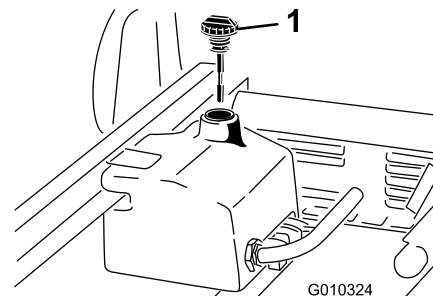

**Figure 20**

- Cap
- 
- Remove the dipstick (Figure 20) from the filler neck and wipe it with a clean rag.

4. Insert the dipstick into the filler neck, then remove it and check the fluid level.

**Note:** The fluid level should be between the 2 marks on the dipstick.

5. If the level is low, add the appropriate fluid to raise the level to the upper mark; refer to [Changing the High-Flow Hydraulic Fluid and Filter](#) (page 54).
6. Install the dipstick and cap onto the filler neck.
7. Start the engine and turn on the attachment.

**Note:** Let them run for about 2 minutes to purge air from the system.

**Important:** The machine must be running before starting the high-flow hydraulics.

8. Shut off the engine and attachment and check for leaks.

### **⚠ WARNING**

Hydraulic fluid escaping under pressure can penetrate skin and cause injury.

- Make sure that all hydraulic fluid hoses and lines are in good condition and all hydraulic connections and fittings are tight before applying pressure to the hydraulic system.
- Keep your body and hands away from pin hole leaks or nozzles that eject high pressure hydraulic fluid.
- Use cardboard or paper to find hydraulic leaks.
- Safely relieve all pressure in the hydraulic system before performing any work on the hydraulic system.
- Seek immediate medical attention if fluid is injected into your skin.

## Checking the Front-Differential-Oil Level

### 4-Wheel-Drive Models Only

**Service Interval:** Every 100 hours/Monthly (whichever comes first)

**Differential-oil type:** Mobil 424 hydraulic oil

1. Position the machine on a level surface.
2. Clean the area around the fill/check plug on side of the differential ([Figure 21](#)).

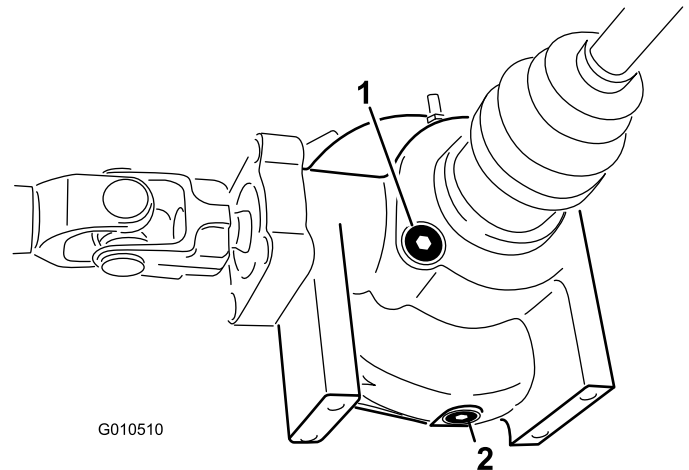

**Figure 21**

1. Fill/check plug

2. Drain plug

3. Remove the fill/check plug and check the level of the oil.

**Note:** The oil should be up to hole.

4. If the oil is low, add specified oil.
5. Install the fill/check plug.

## Checking the Torque of the Wheel Nuts

**Service Interval:** After the first 2 hours

After the first 10 hours

Every 200 hours

### **⚠ WARNING**

Failure to maintain proper torque of the wheel nuts could result in failure or loss of a wheel and may result in personal injury.

Torque the front and rear wheel nuts to 109 to 122 N m (80 to 90 ft-lb) after 1 to 4 hours of operation and again after 10 hours of operation. Torque every 200 hours thereafter.



# Checking the Tire Pressure

**Service Interval:** Before each use or daily

The air pressure in the front tires should be 220 kPa (32 psi) and the rear tires should be 124 kPa (18 psi).

**Important:** Check the tire pressure frequently to ensure proper inflation. If the tires are not inflated to the correct pressure, the tires will wear prematurely and may cause 4-wheel drive to bind.

Figure 22 is an example of tire wear caused by under inflation.

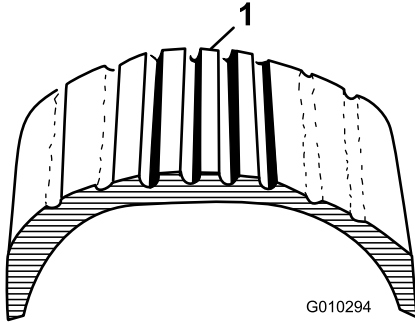

Figure 22

1. Under-inflated tire

Figure 23 is an example of tire wear caused by over inflation.

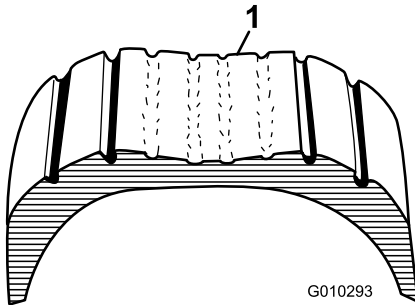

Figure 23

1. Over-inflated tire

# Checking the Brake-Fluid Level

**Service Interval:** Before each use or daily—Check the brake-fluid level. (Check the level before the engine is first started and every 8 hours or daily, thereafter.)

Every 1,000 hours/Every 2 years (whichever comes first)—Change the brake fluid.

**Brake fluid type:** DOT 3 brake fluid

The brake-fluid reservoir is located under the dash.

1. Park the machine on a level surface.
2. Ensure that the fluid level is up to the Full line on the reservoir (Figure 24).

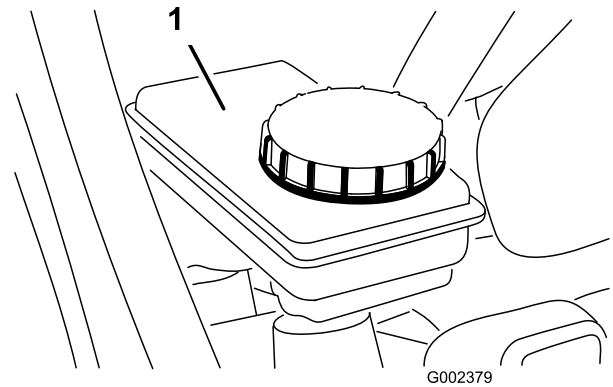

Figure 24

1. Brake-fluid reservoir

3. If the fluid level is low, clean the area around the cap, remove the reservoir cap, and fill the reservoir to the proper level with the specified brake fluid (Figure 24).

**Note:** Do not overfill the reservoir with brake fluid.

**Note:** You can remove the hood access to the reservoir from the front of the machine (Figure 25).

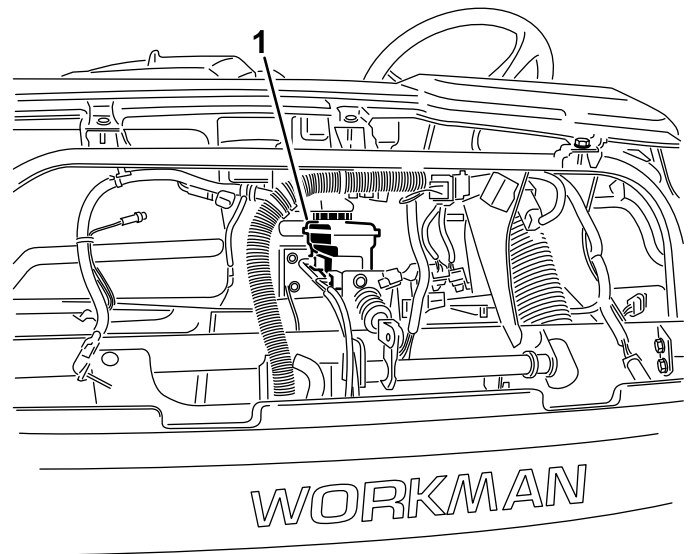

Figure 25

1. Brake-fluid reservoir

G009817

## Starting the Engine

1. Sit on the operator's seat and engage the parking brake.
2. Disengage the PTO and high-flow hydraulics (if equipped) and move the hand-throttle lever to the OFF position (if equipped).
3. Move the shift lever to the NEUTRAL position and press the clutch pedal.
4. Ensure that the hydraulic-lift lever is in the center position.
5. Keep your foot off the accelerator pedal.
6. Turn the starter switch to the ON position.

**Note:** When the glow-plug-indicator light turns on, the engine is ready to start.

7. Rotate the starter key switch to the START position.

**Note:** Release the key immediately when the engine starts and allow it to return to the RUN position.

**Note:** The glow-plug indicator will turn on for an additional 15 seconds when the switch returns to the RUN position.

**Note:** Do not run the starter motor more than 10 seconds at a time or premature starter failure may result. If engine fails to start after 10 seconds, turn the key to the OFF position. Check the controls and starting procedure, wait 10 additional seconds, and repeat the starting operation.

## Driving the Vehicle

1. Release the parking brake.
2. Fully press the clutch pedal.
3. Move the gear-shift lever to first gear.
4. Release the clutch pedal smoothly while pressing the accelerator pedal.
5. When the machine gains enough speed, remove your foot from the accelerator pedal, fully press the clutch pedal, move the gear shift lever to the next gear and release the clutch pedal while pressing the accelerator pedal.
6. Repeat the procedure until the desired speed is attained.

**Important:** Always stop the machine before shifting to reverse a forward gear or to a forward gear from reverse.

**Note:** Avoid long periods of engine idling.

Use the chart below to determine the ground speed of the vehicle at 3,600 rpm.

Gear	Range	Ratio	Speed (kmh)	Speed (mph)
1	L	82.83 : 1	4.7	2.9
2	L	54.52 : 1	7.2	4.5

Gear	Range	Ratio	Speed (kmh)	Speed (mph)
3	L	31.56 : 1	12.5	7.7
1	H	32.31 : 1	12.2	7.6
2	H	21.27 : 1	18.5	11.5
3	H	12.31 : 1	31.9	19.8
R	L	86.94 : 1	4.5	2.8
R	H	33.91 : 1	11.6	7.1

**Important:** Do not attempt to push or tow the machine to get it started. Damage to the drive train could result.

## Stopping the Machine

To stop the machine, remove your foot from the accelerator pedal, press the clutch pedal, then press the brake pedal.

## Shutting off the Engine

To shut off the engine, rotate the starter key to the OFF position and engage the parking brake. Remove the key from the switch to prevent accidental starting.

## Breaking in a New Machine

To provide proper performance and long machine life, follow these guidelines for the first 100 operating hours.

- Check the fluid and engine-oil levels regularly and be alert for indications of overheating in any component of the machine.
- After starting a cold engine, let it warm up for about 15 seconds before shifting into gear.
- Avoid racing the engine.
- To ensure optimum performance of the brake system, burnish (break-in) the brakes before use. To burnish the brakes, bring the vehicle up to full speed, apply the brakes to rapidly stop the vehicle without locking up the tires. Repeat this 10 times, waiting 1 minute between stops to avoid overheating the brakes. This is most effective if the machine is loaded with 454 kg (1,000 lb).
- Vary the machine speed during operation. Avoid excessive idling. Avoid fast starts and quick stops.
- A break-in oil for the engine is not required. The original engine oil is the same type specified for regular oil changes.
- Refer to the [Maintenance \(page 33\)](#) section for any special low hour checks.

# Checking the Safety-Interlock System

**Service Interval:** Before each use or daily

The purpose of the safety-interlock system is to prevent the engine from cranking or starting unless the clutch pedal is pressed.

## ⚠ CAUTION

If the safety-interlock switches are disconnected or damaged, the machine could operate unexpectedly causing personal injury.

- Do not tamper with the interlock switches.
- Check the operation of the interlock switches daily and replace any damaged switches before operating the machine.

**Note:** Refer to *Attachment Operator's Manual* for procedures on checking the attachment interlock system.

## Verifying the Clutch-Interlock Switch

1. Sit on the operator's seat and engage the parking brake.
2. Move the shift lever to the NEUTRAL position.

**Note:** The engine does not start if the hydraulic-lift lever is locked in the forward position.

3. Without pressing the clutch pedal, rotate the ignition key clockwise to the START position.

**Note:** If the engine cranks or starts, there is a malfunction in the interlock system that must be repaired before operating the machine.

## Verifying the Hydraulic-Lift Lever Interlock Switch

1. Sit on the operator's seat and engage the parking brake.
2. Move the shift lever to the NEUTRAL position and ensure that the hydraulic-lift lever is in the center position.
3. Press clutch pedal.
4. Move the hydraulic-lift lever forward and rotate the ignition key clockwise to the START position.

**Note:** If engine cranks or starts, there is a malfunction in the interlock system that must be repaired before operating the machine.

# Ensuring Passenger Safety

Whenever you have a passenger riding in the machine, make sure that he or she is wearing the seat belt and holding on securely. Drive slower and turn less sharply because your passenger does not know what you are going to do next and may not be prepared for turning, stopping, accelerating, and bumps.

You and your passenger should remain seated at all times, keeping arms and legs inside the vehicle. The operator should keep both hands on steering wheel, whenever possible, and the passenger should use the hand holds provided (Figure 26 and Figure 27).

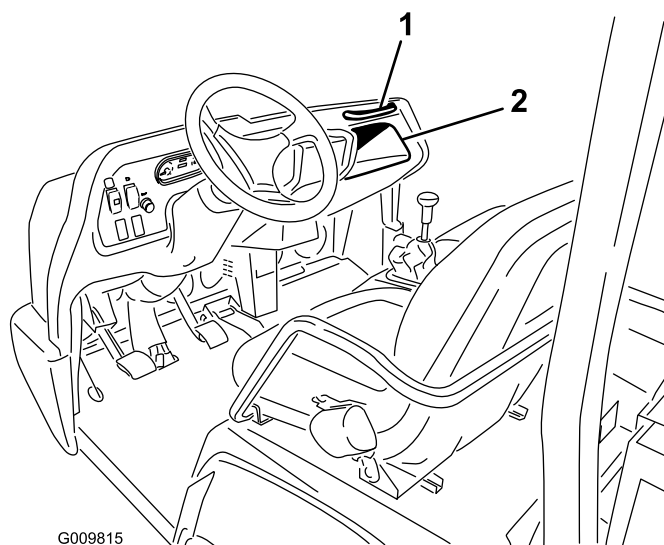

G009815

**Figure 26**

1. Passenger-hand hold
2. Storage compartment

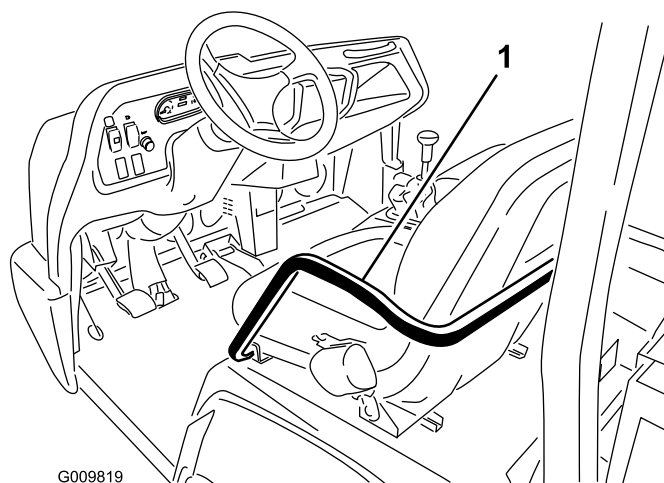

G009819

**Figure 27**

1. Hand hold and hip restraint

Never allow passengers in the cargo box or on any attachments. The vehicle is meant to have 1 driver and only 1 passenger.

## Ensuring Proper Speed

Speed is an important variable leading to accidents. Driving too fast for the conditions can cause you to lose control and have an accident. Speed can also make a minor accident worse. Driving head on into a tree at slow speed can cause injury and damage, but, driving into a tree at high speed can destroy the vehicle and kill you and your passenger.

Never drive too fast for the conditions. If there is any doubt about how fast to drive, slow down.

When using heavy attachments, more than 454 kg (1,000 lb), such as sprayers, top dressers, or spreaders, etc., restrict your operating speed by moving the supervisor switch to the slow position.

## Ensuring Proper Turning

Turning is another important variable leading to accidents. Turning too sharply for the conditions can cause the vehicle to lose traction and skid, or even tip over.

Wet, sandy, and slippery surfaces make turning more difficult and risky. The faster you are going, the worse this situation becomes so, slow down before turning.

During a sharp turn at higher speeds, the inside rear wheel may lift off the ground. This is not a flaw in the design, it happens with most 4-wheel machine including passenger cars. If this happens, you are turning too sharply for the speed at which you are traveling.

## Ensuring Proper Braking

It is good practice to slow down before you get near an obstacle. This gives you extra time to stop or turn away. Hitting an obstacle can damage the machine and its contents. More important, it can injure you and your passenger. Gross machine weight has a major impact on your ability to stop and/or turn. Heavier loads and heavier attachments make a vehicle harder to stop or turn. The heavier the load, the longer it takes to stop.

The braking characteristics also change with no bed or attachment on the machine. Fast stops may cause the rear wheels to lock up before the front wheels lock up, which may affect the control of the machine. It is a good idea to decrease machine speed with no bed or attachment.

Turf and pavement are much slipperier when they are wet. It can take 2 to 4 times as long to stop on wet surfaces as on dry surfaces.

If you drive through standing water deep enough to get the brakes wet, they will not work well until they are dry. After driving through water, you should test the brakes to make sure that they work properly. If they do not, drive slowly in first gear while putting light pressure on the brake pedal. This will dry the brakes out.

Do not downshift for braking on icy or slippery surfaces (wet grass) or while going down a hill because engine braking may cause skidding and loss of control. Shift to a lower gear before starting down a hill.

## Preventing Tip Overs

The machine is equipped with a roll bar, hip restraints, seat belts, and hand hold. The Rollover-Protection System (ROPS) used on the machine reduces the risk of serious or fatal injury in the unlikely event of a tip over, although the system cannot protect the operator from all possible injuries.

Replace a damaged ROPS; do not repair or revise. Any alteration of the ROPS must be approved by the manufacturer.

The best way to prevent accidents involving utility machine is through continuous supervision and training of operators and paying constant attention to the area where they are operating the vehicle.

The best way for operators to prevent serious injury or death to themselves or others is to familiarize themselves with the proper operation of the utility vehicle, to stay alert and to avoid actions or conditions which could result in an accident. In the event of a tip over, the risk of serious injury or death will be reduced if the operator is using the ROPS system and seat belts and is following the instructions provided.

## Operating on Hills

### **▲ WARNING**

**Tipping or rolling the machine on a hill could cause serious personal injury.**

- **Do not operate the vehicle on steep slopes.**
- **If engine stalls or you lose headway on a hill, never attempt to turn vehicle around.**
- **Always back straight down a hill in reverse gear.**
- **Never back down in neutral or with the clutch depressed, using only the brakes.**
- **Never drive across a steep hill, always drive straight up or down.**
- **Avoid turning on a hill.**
- **Do not “drop the clutch” or slam on the brakes. Sudden speed change can initiate a tip over.**

Use extra care when on hills. Never go on hills that are extremely steep. Stopping while going down a hill will take longer than on level ground. Turning while going up or down a hill is more dangerous than turning on the level. Turns while going down hill, especially with the brakes on, and, turning up hill while traversing a hill are particularly dangerous. Even

at a slow speed and without a load, tip overs are more likely if you turn on a hill.

Slow down and shift into a lower gear before starting up or down a hill. If you have to turn while on a hill, do it as slowly and cautiously as possible. Never make sharp or fast turns on a hill.

If you stall or begin to lose headway while climbing a steep hill, quickly apply the brakes, shift to neutral, start the engine and shift to reverse. At idle speed, the engine and transaxle drag will aid the brakes in controlling the vehicle on the hill and help you back down the hill more safely.

Reduce the weight of the load if it is a steep hill or if the load has high center of gravity. Remember, loads can shift, secure them.

**Note:** The machine has excellent hill-climbing ability. The differential lock will increase this ability. Hill climbing traction can also be increased by adding weight to the rear of the vehicle in one of the following ways:

- Adding weight to inside of box, making sure that it is secured.
- Mounting wheel weights to rear wheels.
- Adding liquid ballast (calcium chloride) to rear tires.
- Traction will increase with no passenger in front seat.

## Loading and Dumping

The weight and position of the cargo and passenger can change the machine center of gravity and machine handling. To avoid loss of control resulting in personal injury, follow these guidelines.

Do not carry loads which exceed the load limits described on the machine-weight label.

### **▲ WARNING**

**The bed lowers whenever the dump lever is pushed down, even when the engine is off. Turning off the engine will *not* prevent the box from lowering.**

**Always place the safety support on the extended lift cylinder to hold the box up if you are not going to lower it right away.**

The machine has several combinations of boxes, platforms, and attachments available. These can be used in various combinations that allow for maximum capacity and versatility. The full sized box is 140 cm (55 inches) wide by 165 cm (65 inches) long and can hold up to 1,477 kg (3,249 lb) of evenly-distributed cargo.

Loads vary in how they are distributed. Sand spreads out evenly and quite low. Other items, such as bricks, fertilizer or landscape timbers, stack higher in the box.

The height and weight of the load has a significant influence on tip overs. The higher a load is stacked, the more likely the vehicle is to tip over. You may find that 1,477 kg (3,249 lb) stacks too high for safe operation. Reducing the total weight is one way to reduce the risk of a tip over. Distributing the load as low as possible is another way to reduce the risk of a tip over.

If the load is positioned toward one of the sides, it will make the machine much more likely to tip over on that side. This is especially true when turning if the load is on the outside of the turn.

Never position heavy loads behind the rear axle. If the load is positioned so far to the rear that it is behind the rear axle, it will reduce the weight on the front wheels and this will reduce steering traction. With the load all the way to the back, the front wheels can even come off of the ground when going over bumps or up a hill. This will result in a loss of steering and may lead to the machine tipping over.

**As a general rule, position the weight of the load evenly from front to rear and evenly from side to side.**

If a load is not secured, or you are transporting a liquid in a large container such as a sprayer, it can shift. This shifting happens most often while turning, going up or down hills, suddenly changing speeds, or while driving over rough surfaces. Shifting loads can lead to tip overs. Always secure loads so that they do not shift. Never dump the load while the machine is sideways on the hill.

Heavy loads increase stopping distance and reduce your ability to turn quickly without tipping over.

The rear cargo space is intended for load carrying purposes only, not for passengers.

## Using the Differential Lock

The differential lock increases the machine traction by locking the rear wheels so one wheel will not spin out. This can help when you have heavy loads to haul on wet turf or slippery areas, going up hills, and on sandy surfaces. It is important to remember, however, that this extra traction is only for temporary limited use. Its use does not replace the safe operation, already discussed concerning steep hills and heavy loads.

The differential lock causes the rear wheels to spin at the same speed. When using the differential lock, your ability to make sharp turns is somewhat restricted and may scuff the turf. Use the differential lock only when needed, at slower speeds and only in first or second gear.

## ⚠ WARNING

Tipping or rolling the machine on a hill will cause serious injury.

- The extra traction available with the differential lock can be enough to get you into dangerous situations such as climbing slopes that are too steep to turn around. Be extra careful when operating with the differential lock on, especially on steeper slopes.
- If the differential lock is on when making a sharp turn at a higher speed and the inside rear wheel lifts off the ground, there may be a loss of control which could cause vehicle to skid. Use the differential lock only at slower speeds.

## Using 4-Wheel Drive

### 4-Wheel-Drive Models Only

The automatic, on demand 4-wheel-drive feature, on this vehicle does not require operator activation. The front wheel drive is not engaged (no power delivered to front wheels) until the rear wheels begin to lose traction. The bidirectional clutch senses the rear wheels slipping, engages the front wheel drive, and delivers power to the front wheels. The 4-wheel-drive system continues to deliver power to the front wheels until the rear wheels have enough traction to move the vehicle without slipping. Once this occurs, the system stops delivering power to the front wheels and the handling characteristics become similar to that of a 2-wheel-drive machine. The 4 wheel drive system functions in both forward and reverse; however, when turning, the rear wheels will slip slightly more before power is delivered to the front wheels.

## ⚠ WARNING

Tipping or rolling the machine on a hill will cause serious injury.

The extra traction available with the 4-wheel-drive feature can be enough to get you into dangerous situations such as climbing slopes that are too steep to turn around. Be careful when operating the machine, especially on steeper slopes.

## Transporting the Machine

For moving the machine long distances, use a trailer. Make sure that the machine is secured to the trailer. Refer to [Figure 28](#) and [Figure 29](#) for the location of the tie-down points.

**Important:** Trailers weighing over 680 kg (1,500 lb) are required to be equipped with trailer brakes.

**Note:** Load the machine on the trailer with the front of the machine facing forward. If that is not possible, secure the

machine hood to the frame with a strap, or remove the hood and transport and secure it separately or the hood may blow off during transport.

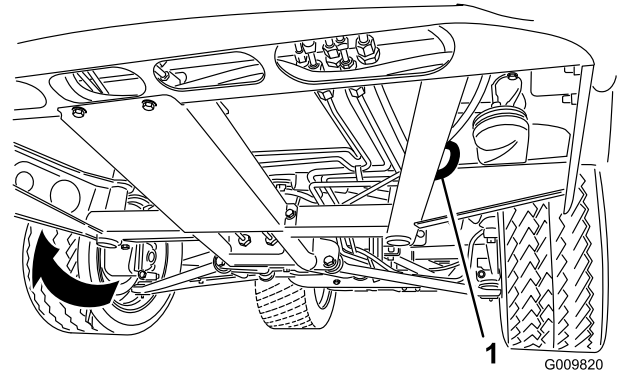

Figure 28

1. Eye hole in the frame (each side)

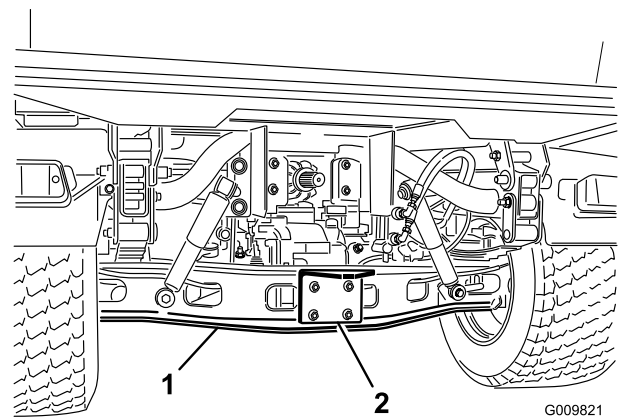

Figure 29

1. Axle
2. Hitch plate

## Towing the Machine

In case of an emergency, the machine can be towed for a short distance. However, Toro does not recommend this as a standard procedure.

## ⚠ WARNING

Towing at excessive speeds could cause the machine to lose steering control.

Never tow the machine at faster than 8 kph (5 mph).

Towing the machine is a 2-person job. Affix a tow line to holes in the front frame member. Move the shift lever to the NEUTRAL position and release the parking brake. If you must move the machine a considerable distance, transport it on a truck or trailer.

**Note:** The power steering does not function, making it difficult to steer.

# Towing a Trailer with the Machine

The machine is capable of pulling trailers and attachments of greater weight than the machine itself.

Several types of tow hitches are available for the machine, depending on your application. Contact your Authorized Toro Distributor for details.

When equipped with a tow hitch bolted onto the rear axle tube, your machine can tow trailers or attachments with a Gross Trailer Weight (GTW) up to 1,587 kg (3,500 lb). Always load a trailer with 60% of the cargo weight in the front of the trailer. This places approximately 10% (272 kg (600 lb) max.) of the Gross Trailer Weight (GTW) on the tow hitch of the machine.

Trailer brakes are required whenever you tow a trailer over 680 kg (1,500 lb) GTW is towed behind a machine.

When hauling cargo or towing a trailer (attachment), do not overload your machine or trailer. Overloading can cause poor performance or damage to the brakes, axle, engine, transaxle, steering, suspension, body structure, or tires.

**Important:** To reduce potential for drive line damage, use low range.

When towing fifth-wheel attachments, like a fairway aerator, always install the wheel bar (included with the fifth wheel kit) to prevent the front wheels from lifting off the ground if the towed attachments movement is suddenly impaired.

# Using the Hydraulic Control

The hydraulic control supplies hydraulic power from the machine pump whenever the engine runs. The power can be used through the quick couplers at the rear of the machine.

## ⚠ CAUTION

Hydraulic fluid escaping under pressure can have sufficient force to penetrate skin and do serious damage.

Use care when connecting or disconnecting hydraulic quick couplers. Shut off the engine, apply the parking brake, lower the attachment, and place the remote hydraulic valve in the float detent position to relieve the hydraulic pressure before connecting or disconnecting the quick couplers.

**Important:** If multiple machines use the same attachment, cross contamination of the transmission fluid may occur. Change the transmission fluid more frequently.

# Using the Hydraulic-Bed-Lift Lever to Control Hydraulic Attachments

- OFF Position

This is the normal position for the control valve when it is not being used. In this position, the work ports of the control valve are blocked and any load is held by the check valves in both directions.

- RAISE (Quick Coupler “A”) Position

This is the position which lifts the bed, rear-hitch attachment, or applies pressure to quick coupler A. This also allows hydraulic fluid to return from quick coupler B to flow back into the valve and then out to the reservoir. This is a momentary position and when the lever is released it spring returns to the center, OFF position.

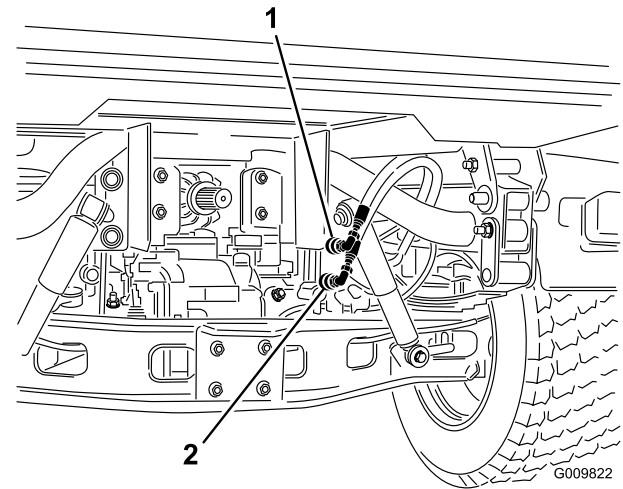

Figure 30

1. Quick coupler A position
2. Quick coupler B position

- LOWER (Quick Coupler “B”) Position

This position lowers the bed, rear-hitch attachment, or applies pressure to quick coupler B. This also allows hydraulic fluid to return from quick coupler A to flow back into the valve and then out to the reservoir. This is a momentary position and when the lever is released it spring returns to the center off position. Momentarily holding and then releasing the control lever in this position will provide hydraulic-fluid flow to quick coupler B which provides power down on the rear hitch. When released, it will hold the down pressure on the hitch.

**Important:** If used with a hydraulic cylinder, holding the control lever in the lower position causes the hydraulic-fluid flow to go over a relief valve, which can damage the hydraulic system.

- ON Position

This position is similar to Lower (quick coupler B position). It also directs hydraulic fluid to quick coupler B except that the lever is held in this position by a detent lever in the control panel. This allows hydraulic fluid to flow continuously to equipment that uses a

hydraulic motor. This position must only be used on attachments with a hydraulic motor attached.

**Important:** If used with a hydraulic cylinder or no attachment, the ON position causes the hydraulic-fluid flow to go over a relief valve which can damage the hydraulic system. Use this position only momentarily or with a motor attached.

**Important:** Check the hydraulic-fluid level after installation of an attachment. Check the operation of the attachment by cycling the attachment several times to purge air from the system, then check hydraulic-fluid level again. The attachment cylinder will slightly affect the fluid level in the transaxle. Operating the vehicle with a low hydraulic-fluid level can damage the pump, remote hydraulics, power steering, and the vehicle transaxle.

## Connecting the Quick Couplers

**Important:** Clean dirt from quick couplers before connecting. Dirty couplers can introduce contamination into the hydraulic system

1. Pull back the locking ring on the coupler.
2. Insert the hose nipple into the coupler until it snaps into position.

**Note:** When attaching remote equipment to the quick couplers, determine which side requires pressure, then attach that hose to quick coupler B, which will have pressure when the control lever is pushed forward or locked in the ON position.

## Disconnecting the Quick Couplers

**Note:** With both the vehicle and attachment turned off, move the lift lever back and forth to remove the system pressure and ease the disconnection of the quick couplers.

1. Pull back the locking ring on the coupler.
2. Pull the hose firmly from the coupler.

**Important:** Clean and install the dust plug and dust covers to the quick coupler ends when not in use.

## Troubleshooting the Hydraulic Control

- Difficulty in connecting or disconnecting quick couplers.
  - The pressure not relieved (the quick coupler is under pressure).
- The power steering is turning with great difficulty or it is not turning at all.
  - The hydraulic-fluid level is low.
  - The hydraulic-fluid temperature is hot.
  - The pump is not operating.
- There are hydraulic leaks.
  - The fittings are loose.
  - The fitting is missing the O-ring.
- An attachment does not function.
  - The quick couplers are not fully engaged.
  - The quick couplers are interchanged.
- There is a squealing noise.
  - Remove the valve left in the ON detent position causing hydraulic fluid to flow over the relief valve.
  - The belt is loose.
- The engine does not start.
  - The hydraulic lever is locked in the forward position



# Maintenance

## Recommended Maintenance Schedule(s)

Maintenance Service Interval	Maintenance Procedure
After the first 2 hours	<ul style="list-style-type: none"> <li>• Torque the front and rear wheel nuts.</li> </ul>
After the first 8 hours	<ul style="list-style-type: none"> <li>• Check the condition and tension of the alternator belt.</li> </ul>
After the first 10 hours	<ul style="list-style-type: none"> <li>• Torque the front and rear wheel nuts.</li> <li>• Check the adjustment of the shift cables.</li> <li>• Check the adjustment of the parking brake.</li> <li>• Replace the hydraulic filter.</li> <li>• Change the high-flow hydraulic fluid filter (TC models only).</li> </ul>
After the first 50 hours	<ul style="list-style-type: none"> <li>• Change the engine oil and filter.</li> <li>• Adjust the engine valve clearance.</li> </ul>
Before each use or daily	<ul style="list-style-type: none"> <li>• Check the engine-oil level.</li> <li>• Check the level of the coolant.</li> <li>• Check the transaxle/hydraulic-fluid level. (check the fluid level before the engine is first started and every 8 hours or daily, thereafter.)</li> <li>• Check the high flow hydraulic-fluid level (TC models only); (check the level of hydraulic fluid before the engine is first started, and daily thereafter).</li> <li>• Check the tire pressure.</li> <li>• Check the brake-fluid level. (Check the level before the engine is first started and every 8 hours or daily, thereafter.)</li> <li>• Check the operation of the safety-interlock system.</li> <li>• Drain water or other contaminants from the water separator.</li> <li>• Remove debris from the engine area and radiator (clean more frequently in dirty conditions).</li> </ul>
Every 25 hours	<ul style="list-style-type: none"> <li>• Remove the air-cleaner cover and clean out the debris.</li> </ul>
Every 50 hours	<ul style="list-style-type: none"> <li>• Check the battery-fluid level (every 30 days if in storage).</li> <li>• Check the battery-cable connections.</li> </ul>
Every 100 hours	<ul style="list-style-type: none"> <li>• Check the level of front differential oil (4-wheel-drive models only).</li> <li>• Grease all bearings and bushings (lubricate more frequently in heavy duty applications).</li> <li>• Change the air-cleaner filter (more frequently in dusty or dirty conditions).</li> <li>• Inspect the condition of the tires.</li> </ul>
Every 200 hours	<ul style="list-style-type: none"> <li>• Torque the front and rear wheel nuts.</li> <li>• Change the engine oil and filter.</li> <li>• Inspect the constant-velocity boot for cracks, holes, or a loose clamp (4-wheel-drive models only).</li> <li>• Check the adjustment of the shift cables.</li> <li>• Check the adjustment of the high-to-low cable.</li> <li>• Check the adjustment of the differential-lock cable.</li> <li>• Check the adjustment of the parking brake.</li> <li>• Check the adjustment of the brake pedal.</li> <li>• Check the condition and tension of the alternator belt.</li> <li>• Check the adjustment of the clutch pedal.</li> <li>• Inspect the service and parking brakes.</li> </ul>
Every 400 hours	<ul style="list-style-type: none"> <li>• Check the fuel lines and connections.</li> <li>• Replace the fuel filter.</li> <li>• Check the front-wheel alignment.</li> <li>• Visually inspect the brakes for worn brake shoes.</li> </ul>
Every 600 hours	<ul style="list-style-type: none"> <li>• Adjust the engine valve clearance.</li> </ul>

Maintenance Service Interval	Maintenance Procedure
Every 800 hours	<ul style="list-style-type: none"> <li>• Change the front-differential oil (4-wheel-drive models only).</li> <li>• Change the hydraulic fluid and clean the strainer.</li> <li>• Replace the hydraulic filter.</li> <li>• Change the high-flow hydraulic fluid and filter (TC models only).</li> </ul>
Every 1,000 hours	<ul style="list-style-type: none"> <li>• Change the brake fluid.</li> <li>• Drain/flush the fuel tank.</li> <li>• Flush or replace the coolant-system fluid.</li> </ul>

**Note:** Determine the left and right sides of the machine from the normal operating position.

## **⚠ DANGER**

Only qualified and authorized personnel should maintain, repair, adjust, or inspect the machine.

Avoid fire hazards and have fire protection equipment present in the work area. Do not use an open flame to check level or leakage of fuel, battery electrolyte, or coolant. Do not use open pans of fuel or flammable cleaning fluids for cleaning parts.

## **⚠ CAUTION**

If you leave the key in the starter switch, someone could accidentally start the engine and seriously injure you or other bystanders.

Remove the key from the starter switch before you do any maintenance.

## **Operating in Adverse Conditions**

**Important:** If the machine is subjected to any of the conditions listed below, perform maintenance twice as frequently:

- Desert operation
- Cold-climate operation below 0°C (32°F)
- Trailer towing
- Frequent operation on dusty roads
- Construction work
- After extended operation in mud, sand, water, or similar dirty conditions, have your brakes inspected and cleaned as soon as possible. This will prevent any abrasive material from causing excessive wear.

# Premaintenance Procedures

Many of the subjects covered in this maintenance section require raising and lowering the bed. The following precautions must be taken or serious injury or death could result.

## ⚠ WARNING

A raised bed full of material without the proper safety support rod may lower unexpectedly. Working under an unsupported raised bed may cause injury to you or others.

- Before servicing or making adjustments to the machine, shut off the engine, set the parking brake, and remove the key from the ignition switch.
- Remove any load material from the bed or other attachment and insert the safety support on a fully extended cylinder rod before working under a raised bed.

## Using the Bed Support

**Important:** Always install or remove the bed support from the outside of the bed.

1. Raise the bed until the lift cylinders are fully extended.
2. Remove the bed support from the storage brackets on the back of the ROPS panel (Figure 31).

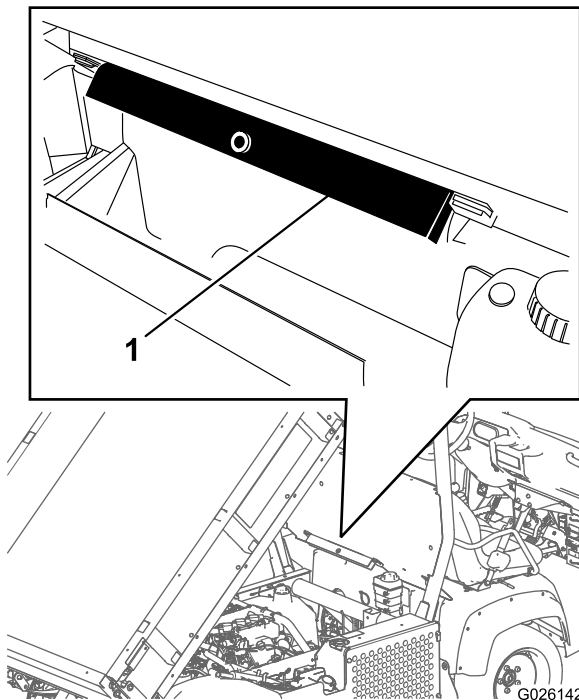

Figure 31

1. Bed support

3. Push the bed support onto the cylinder rod, ensuring that the support end tabs rest on the end of the cylinder barrel, and on the cylinder rod end (Figure 32).

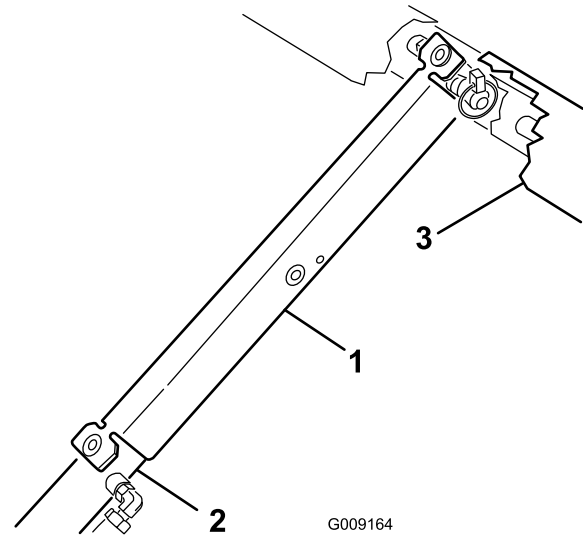

Figure 32

1. Bed support
2. Cylinder barrel
3. Bed

4. Remove the bed support from the cylinder and insert it into the brackets on the back of the ROPS panel.

**Important:** Do not try to lower the bed with the bed-safety support on the cylinder.

## Removing the Full Bed

1. Start the engine, engage the hydraulic-lift lever, and lower the bed until the cylinders are loose in the slots.
2. Release the lift lever and turn off the engine.
3. Remove the lynch pins from the outer ends of the cylinder rod clevis pins (Figure 33).

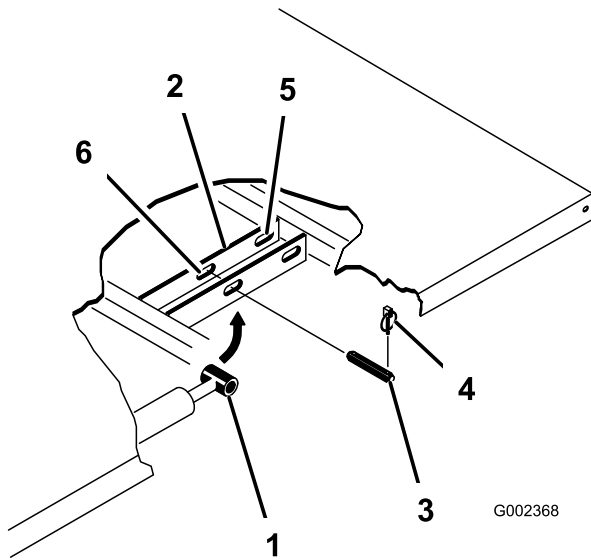

Figure 33

- |                       |                          |
|-----------------------|--------------------------|
| 1. Cylinder rod end   | 4. Lynch pin             |
| 2. Bed-mounting plate | 5. Rear slots (full bed) |
| 3. Clevis pin         | 6. Front slots (2/3 bed) |

4. Remove the clevis pins securing the cylinder rod ends to the bed-mounting plates by pushing the pins toward the inside (Figure 33).
5. Remove the lynch pins and clevis pins securing the pivot brackets to the frame channels (Figure 33).
6. Lift the bed off the machine.

**Important:** The full bed weighs approximately 148 kg (325 lb), so do not try to install or remove it by yourself.

Use an overhead hoist or get the help of 2 or 3 other people.

7. Store the cylinders in the storage clips.
8. Engage the hydraulic-lift-lock lever on the machine to prevent accidental extension of the lift cylinders.

## Installing the Full Bed

**Note:** If the bed sides will be installed on the flat bed, it is easier to install them before installing the bed on the machine.

**Note:** Ensure that the rear pivot plates are bolted to the bed frame/channel so that the lower end angles to the rear (Figure 34).

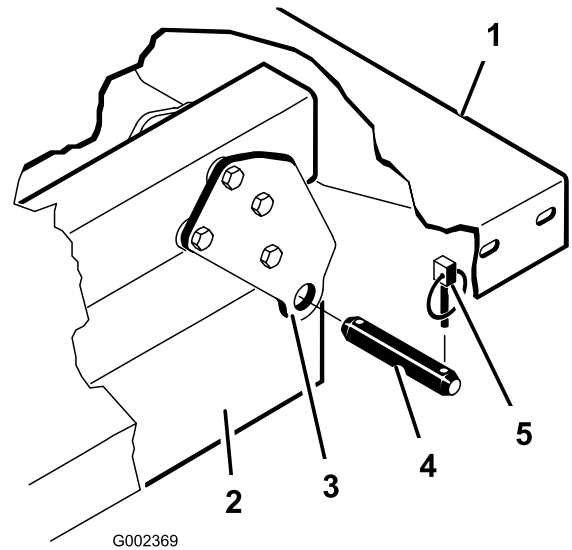

Figure 34

- |                             |               |
|-----------------------------|---------------|
| 1. Left, rear corner of bed | 4. Clevis pin |
| 2. Machine frame channel    | 5. Lynch pin  |
| 3. Pivot plate              |               |

**Important:** The full bed weighs approximately 148 kg (325 lb), so do not try to install or remove it by yourself.

Use an overhead hoist or get the help of 2 or 3 other people.

**Note:** Ensure that the spacer brackets and wear blocks (Figure 35) are installed with the carriage-bolt heads positioned inside the machine.

# Raising the Machine

## ⚠ DANGER

A machine on a jack may be unstable and slip off of the jack, injuring anyone beneath it.

- Do not start the machine while the machine is on a jack.
- Always remove the key from the switch before getting off of the machine.
- Block the tires when the machine is on a jack.
- Do not start the engine while the machine is on a jack, because the engine vibration or wheel movement could cause the machine to slip off the jack.
- Do not work under the machine without jack stands supporting it. The machine could slip off a jack, injuring anyone beneath it.
- When jacking up the front of the vehicle, always place a wooden block (or similar material) between the jack and the machine frame.
- The jacking point at the front of the machine is under the front center frame support (Figure 36) and at the rear it is under the axle (Figure 37).

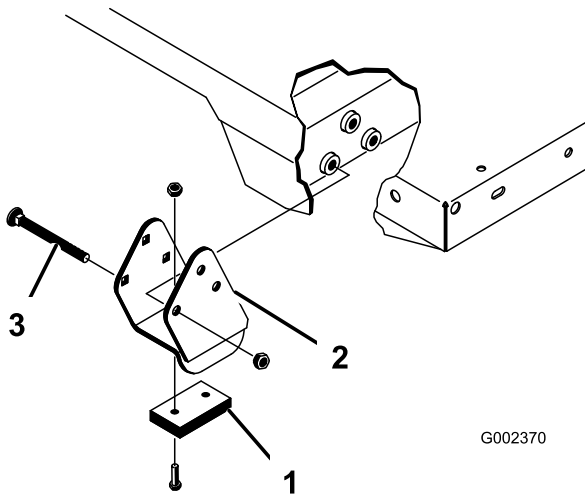

Figure 35

1. Wear block
2. Spacer bracket
3. Carriage bolt

1. Ensure that the lift cylinders are fully retracted.
2. Carefully set the bed onto the machine frame, aligning the rear bed pivot-plate holes with the holes in the rear frame channel and install 2 clevis pins and lynch pins (Figure 35).
3. With the bed lowered, secure each cylinder rod end, to the appropriate slots in the bed-mounting plates with a clevis pin and lynch pin.
4. Insert the clevis pin from outside of the bed with the lynch pin toward the outside (Figure 35).

**Note:** The rear slots are for a full bed installation and front slots are for a 2/3 bed installation.

**Note:** The engine may need to be started to extend or retract the cylinders for alignment with the holes.

**Note:** The unused slot can be plugged with a bolt and nut to prevent assembly errors.

5. Start the engine and engage the hydraulic-lift lever to raise the bed.
6. Release the lift lever and turn off the engine.
7. Install the bed-safety support to prevent accidental lowering of the bed; refer to [Using the Bed Support](#) (page 35).
8. Install the lynch pins to the inside ends of the clevis pins.

**Note:** If the automatic-tailgate release has been installed on the bed, ensure that the front dump link rod has been placed on the inside of the left side clevis pin before you install the lynch pin.

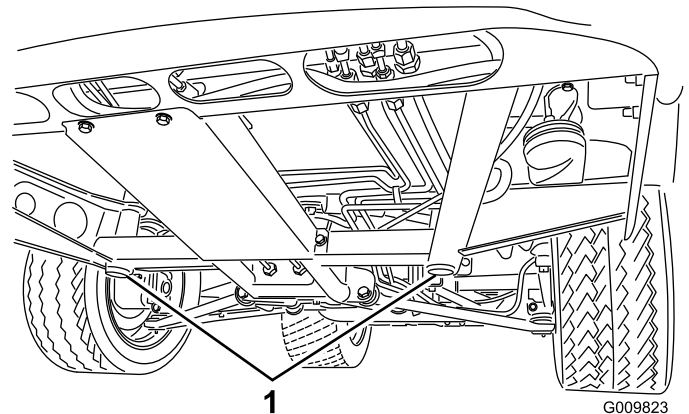
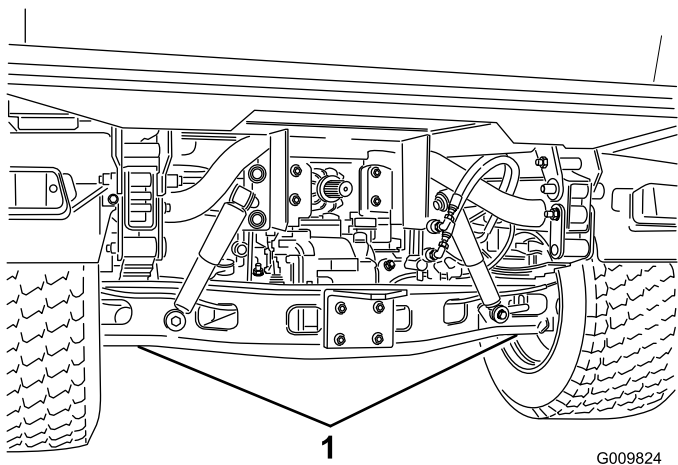

Figure 36

1. Front jacking points



**Figure 37**

1. Rear jacking points

## Installing the Hood

1. Connect the lights.
2. Insert the top mounting tabs into the frame slots.
3. Insert the lower mounting tabs into the frame slots.
4. Ensure that the hood is fully engaged in the top, sides and bottom grooves.

## Removing the Hood

1. While grasping the hood in the headlight openings, lift up the hood to release the lower mounting tabs from the frame slots (Figure 38).

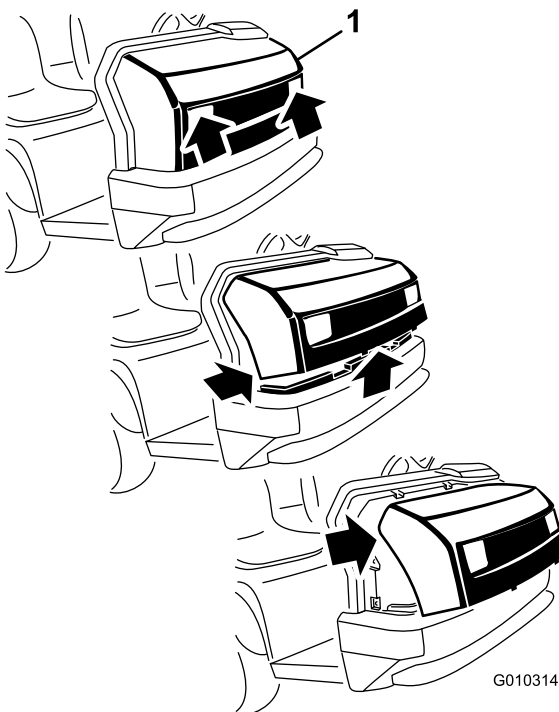

**Figure 38**

1. Hood
2. Pivot the bottom of the hood upward until the top mounting tabs can be pulled from the frame slots (Figure 38).
3. Pivot the top of the hood forward, and unplug the wire connectors from the head lights (Figure 38).
4. Remove the hood.

# Lubrication

## Greasing the Bearings and Bushings

**Service Interval:** Every 100 hours (lubricate more frequently in heavy duty applications).

The machine has grease fittings that must be lubricated regularly with No. 2 lithium grease.

The grease fitting locations and quantities are as follows:

- Ball joints (4), tie rods (2), pivot mounts (2) and steering cylinder (2) as shown in [Figure 39](#)
- Spring tower (2) as shown in [Figure 40](#)
- Clutch (1), accelerator (1), and brake (1) as shown in [Figure 41](#)
- U-joint (18) and 4-wheel-drive shaft (3) as shown in [Figure 42](#)

**Important:** When greasing the drive shaft universal shaft bearing crosses, pump grease until it comes out of all 4 cups at each cross.

1. Wipe each grease fitting clean so foreign matter cannot be forced into the bearing or bushing.
2. Pump grease into each bearing or bushing.
3. Wipe off excess grease.

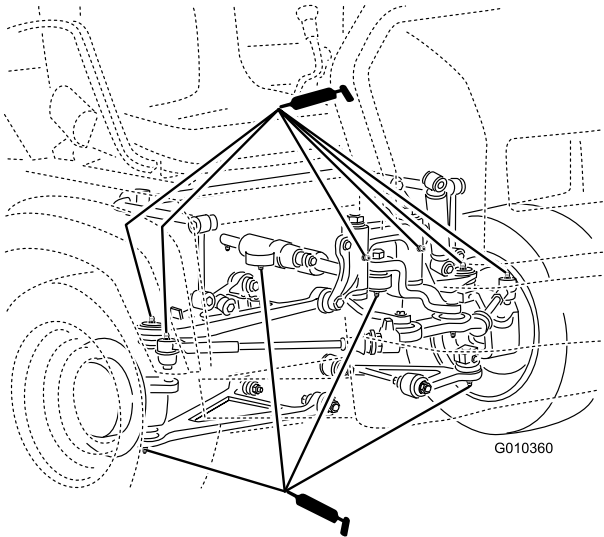

Figure 39

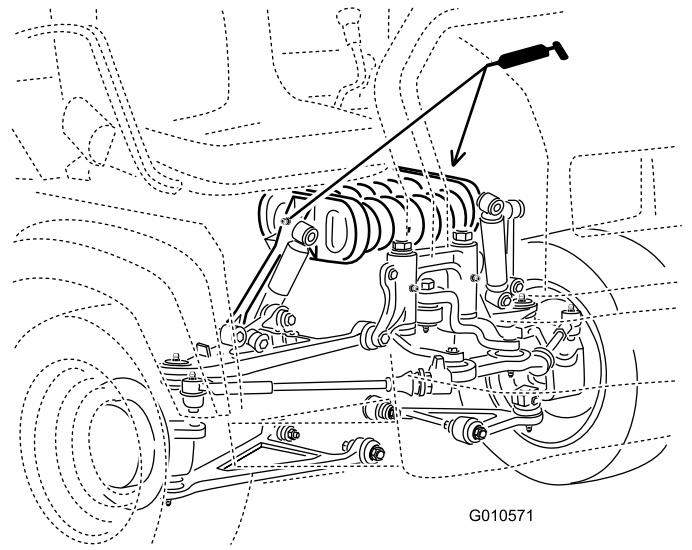

Figure 40

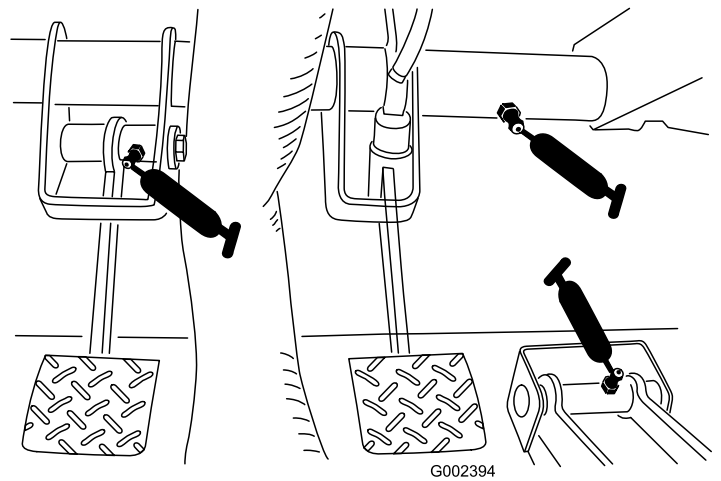
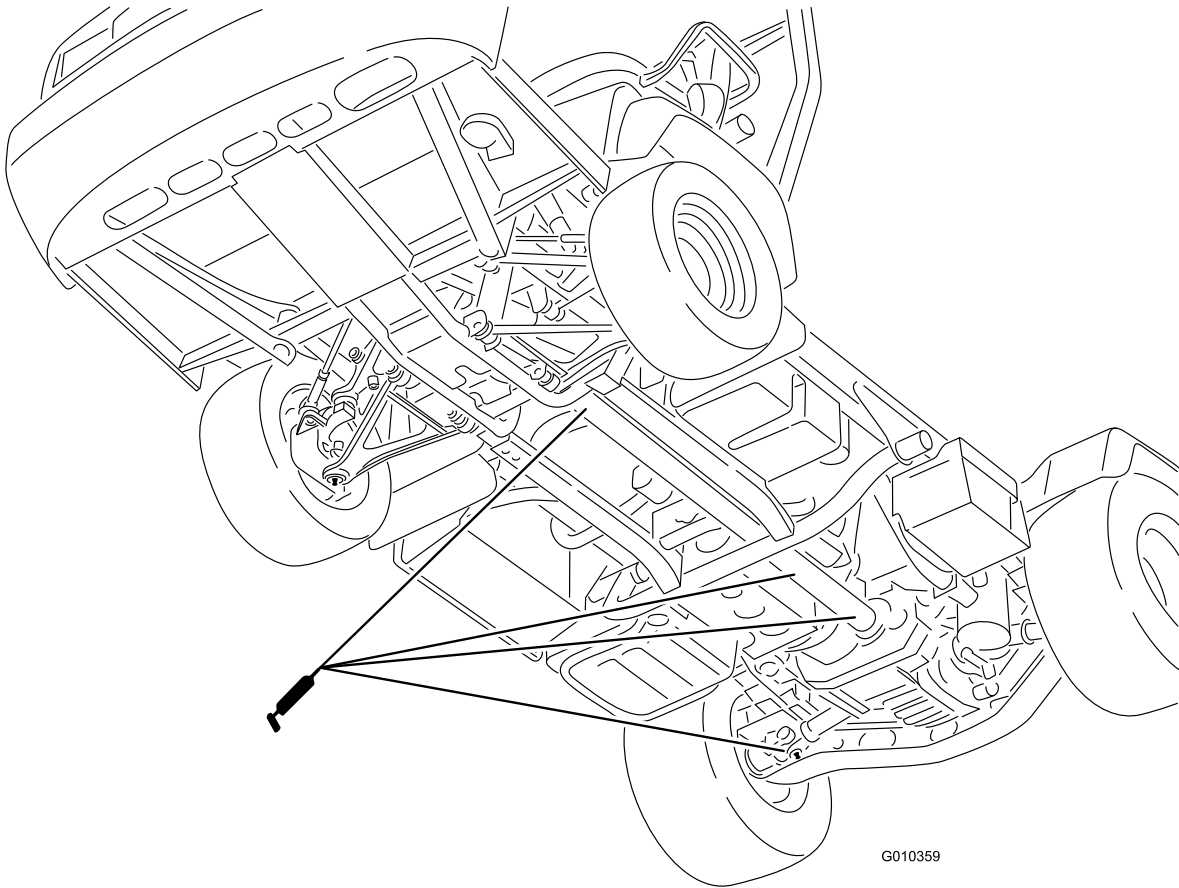

Figure 41



G010359

**Figure 42**



# Engine Maintenance

## Servicing the Air Cleaner

**Service Interval:** Every 25 hours—Remove the air-cleaner cover and clean out the debris.

Every 100 hours—Change the air-cleaner filter (more frequently in dusty or dirty conditions).

Inspect the air cleaner and hoses periodically to maintain maximum engine protection and to ensure maximum service life. Check the air-cleaner body for damage, which could possibly cause an air leak. Replace a damaged air-cleaner body.

Inspect and change the air-cleaner filter as described in the following procedure:

1. Release the latches on the air cleaner and pull the air-cleaner cover off the air-cleaner body (Figure 43).

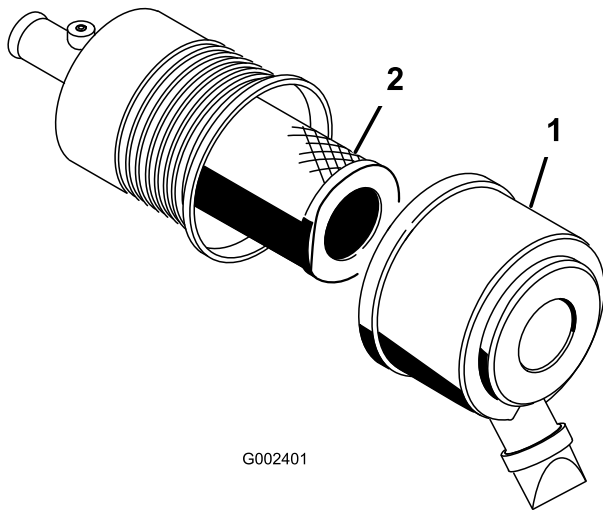

G002401

**Figure 43**

1. Air-cleaner cover
2. Filter

2. Squeeze the dust cap sides to open it and knock the dust out.
3. Gently slide the filter out of the air-cleaner body (Figure 43).

**Note:** Avoid knocking the filter into the side of the body.

**Note:** Do not attempt to clean the filter.

4. Inspect the new filter for damage by looking into the filter while shining a bright light on the outside of the filter.

**Note:** Holes in the filter will appear as bright spots.

Inspect the element for tears, an oily film, or damage to the rubber seal. If the filter is damaged do not use it.

To prevent engine damage, always operate the engine with the air filter and cover installed.

Take special care to keep particulates from dropping into the clean areas of the air-filter housing.

5. Carefully slide the filter over the body tube (Figure 43).

**Note:** Ensure that it is fully seated by pushing on the outer rim of the filter while installing it.

6. Install the air-cleaner cover with the side facing up, and secure the latches (Figure 43).

## Changing the Engine Oil and Filter

**Service Interval:** After the first 50 hours

Every 200 hours

**Engine-oil quantity:** 3.2 L (3.4 US qt) (with a filter)

**Engine-oil type:** Detergent engine oil API SJ or higher

**Engine-oil viscosity:** 10W-30; Choose an engine-oil viscosity according to the ambient-air temperature to the table in Figure 44.

### USE THESE SAE VISCOSITY OILS

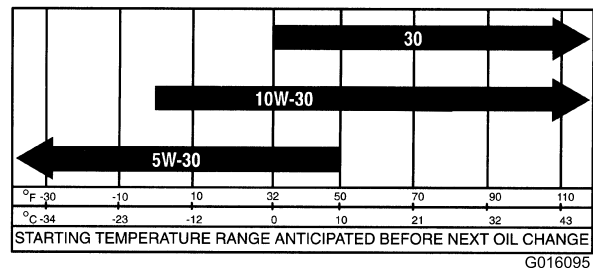

**Figure 44**

1. Raise the bed (if equipped), and place the safety support on the extended-lift cylinder to hold up the bed.
2. Remove the drain plug and let the oil flow into a drain pan (Figure 45).

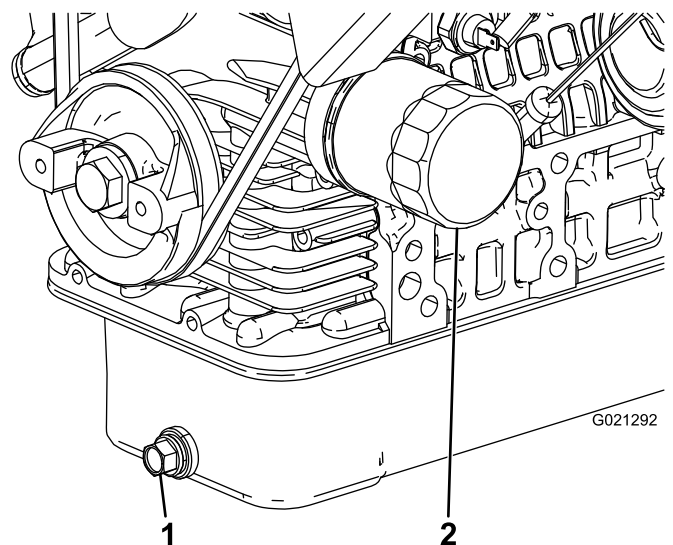

G021292

**Figure 45**

1. Engine-oil-drain plug
2. Engine-oil filter

3. When the oil stops, install the drain plug.
4. Remove the oil filter (Figure 45).
5. Apply a light coat of clean oil to the new filter seal before screwing it on.
6. Screw the filter on until the gasket contacts the mounting plate, then tighten the filter 1/2 to 2/3 of a turn.

**Note: Do not overtighten.**

7. Add the specified oil to the crankcase.

## Fuel System Maintenance

### Checking the Fuel Lines and Connections

**Service Interval:** Every 400 hours/Yearly (whichever comes first)

Every 1,000 hours/Every 2 years (whichever comes first)

Inspect the fuel lines and connections for deterioration, damage, or loose connections.

### Servicing the Fuel Filter/Water Separator

#### Draining the Fuel Filter/Water Separator

**Service Interval:** Before each use or daily—Drain water or other contaminants from the water separator.

1. Place a clean container under the fuel filter (Figure 46).
2. Loosen the drain plug on the bottom of the filter canister.

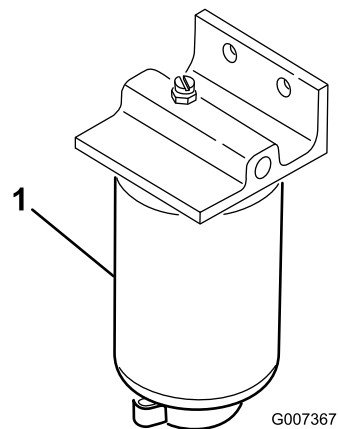

**Figure 46**

1. Filter canister

3. Tighten the drain plug on the bottom of the filter canister.

## Changing the Fuel Filter

**Service Interval:** Every 400 hours—Replace the fuel filter.

1. Drain the water from the water separator; refer to [Draining the Fuel Filter/Water Separator](#) (page 42).
2. Clean the area where the filter mounts ([Figure 46](#)).
3. Remove the filter and clean the mounting surface.
4. Lubricate the gasket on the filter with clean oil.
5. Install the filter by hand until the gasket contacts mounting surface, then rotate it an additional 1/2 turn.
6. Tighten the drain plug on the bottom of the filter canister.

# Electrical System Maintenance

## Servicing the Fuses

The fuses for the electrical system are located under the center of the dash panel ([Figure 47](#) and [Figure 48](#)).

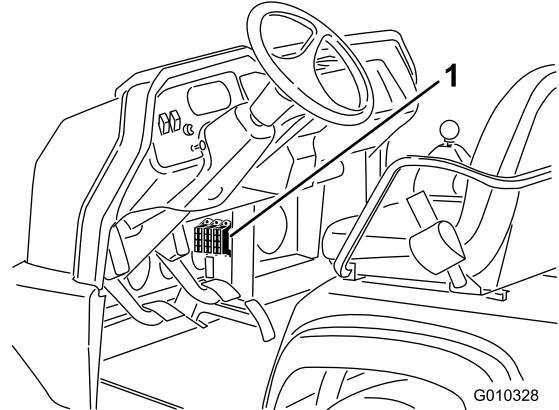

**Figure 47**

1. Fuses

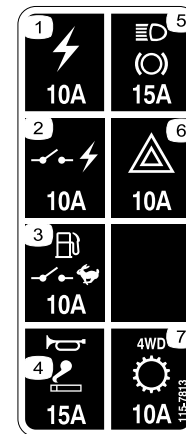

**Figure 48**

1. Power outlet—10 A
2. Switched power—10 A
3. Fuel pump, supervisor switch—10 A
4. Horn, power point—15 A
5. Lights, brake—15 A
6. Hazard—10 A
7. 4WD, Transmission—10 A

# Jump-Starting the Machine

## ⚠ WARNING

Jump-starting the machine can be dangerous, causing personal injury or damage to the electrical components in the machine.

- Never jump-start with a voltage source greater than 15 VDC; this will damage the electrical system.
- Never attempt to jump-start a discharged battery that is frozen. It could rupture or explode during jump-starting.
- Observe all battery warnings while jump-starting your machine.
- Be sure that your machine is not touching the jump-start machine.
- Connecting cables to the wrong post could result in personal injury and/or damage to the electrical system.

1. Squeeze the battery cover to release the tabs from the battery base, and remove the battery cover from the battery base (Figure 49).

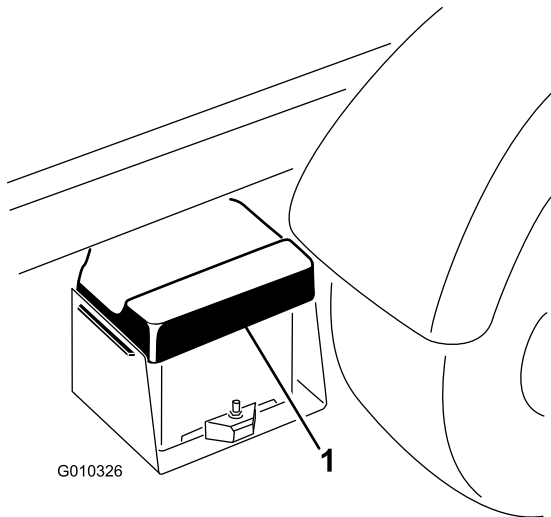

Figure 49

1. Battery cover

2. Connect a jumper cable between the positive posts of the 2 batteries (Figure 50).

**Note:** The positive post may be identified by a + sign on top of the battery cover.

3. Connect 1 end of the other jumper cable to the negative terminal of the battery in the other machine.

**Note:** The negative terminal has “NEG” on the battery cover.

**Note:** Do not connect the other end of the jumper cable to the negative post of the discharged battery. Connect the jumper cable to the engine or frame. Do not connect the jumper cable to the fuel system.

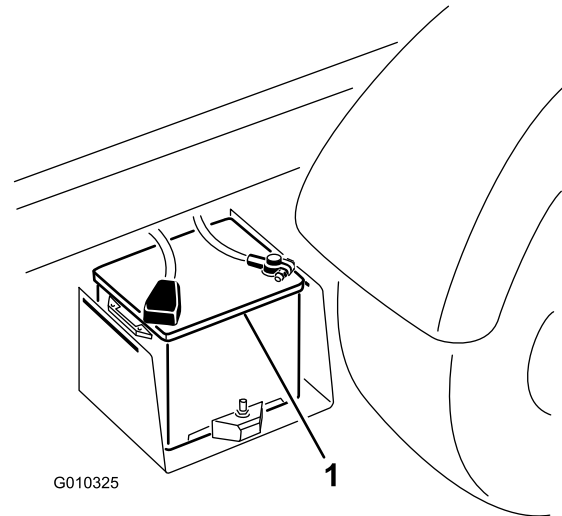

Figure 50

1. Battery

4. Start the engine in the machine providing the jump-start.

**Note:** Let it run for a few minutes, then start the engine.

5. Remove the negative jumper cable first from the engine, then the battery in the other machine.
6. Install the battery cover to the battery base.

# Servicing the Battery

**Service Interval:** Every 50 hours—Check the battery-fluid level (every 30 days if in storage).

Every 50 hours—Check the battery-cable connections.

## ⚠ WARNING

### CALIFORNIA

#### Proposition 65 Warning

Battery posts, terminals, and related accessories contain lead and lead compounds, chemicals known to the State of California to cause cancer and reproductive harm. Wash hands after handling.

## ⚠ DANGER

Battery electrolyte contains sulfuric acid, which is a deadly poison and causes severe burns.

- Do not drink electrolyte and avoid contact with skin, eyes or clothing. Wear safety glasses to shield your eyes and rubber gloves to protect your hands.
- Fill the battery where clean water is always available for flushing the skin.
- Keep the battery-electrolyte level properly maintained.
- Keep the top of the battery clean by washing it periodically with a brush dipped in ammonia or bicarbonate of soda solution. Flush the top surface with water after cleaning. Do not remove the fill cap while cleaning.
- Ensure that the battery cables are kept tight on the terminals to provide good electrical contact.
- If corrosion occurs at terminals, remove the battery cover, disconnect the cables (negative (–) cable first), and scrape the clamps and terminals separately. Connect the cables (positive (+) cable first) and coat the terminals with petroleum jelly.
- Maintain cell electrolyte level with distilled or demineralized water. Do not fill the cells above the bottom of the fill ring inside each cell.
- If you store the machine in a location where temperatures are extremely high, the battery runs down more rapidly than if the machine is stored in a location where temperatures are cool.

# Drive System Maintenance

## Changing the Front-Differential Oil

### 4-Wheel-Drive Models Only

**Service Interval:** Every 800 hours (4-wheel-drive models only).

**Differential-oil specification:** Mobil 424 hydraulic oil

1. Position the machine on a level surface, shut off the engine, set the parking brake, and remove the key from the ignition switch.
2. Clean the area around the drain plug on the side of the differential (Figure 51).
3. Place a drain pan under the drain plug.

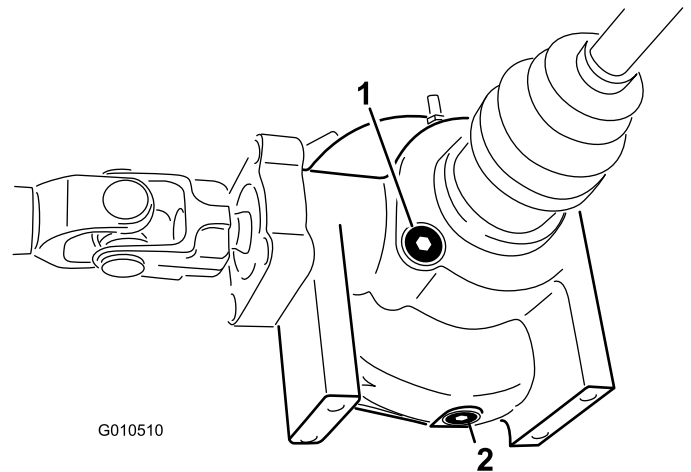

Figure 51

1. Fill/check plug

2. Drain plug

4. Remove the drain plug and let the oil flow into the drain pan.
5. Install and tighten the plug when the oil stops draining.
6. Clean the area around the fill/check plug on the bottom of the differential.
7. Remove the fill/check plug and add specified oil until the oil level is up to the hole.
8. Install the fill/check plug.

# Inspecting the Constant-Velocity Boot

## 4-Wheel-Drive Models Only

**Service Interval:** Every 200 hours (4-wheel-drive models only).

Inspect the constant-velocity boot for cracks, holes, or a loose clamp. Contact your Authorized Toro Distributor for repair if you find any damage.

## Adjusting the Shift Cables

**Service Interval:** After the first 10 hours

Every 200 hours

1. Move the shift lever to the NEUTRAL position.
2. Remove the clevis pins securing the shift cables to the transaxle-shift arms (Figure 52).

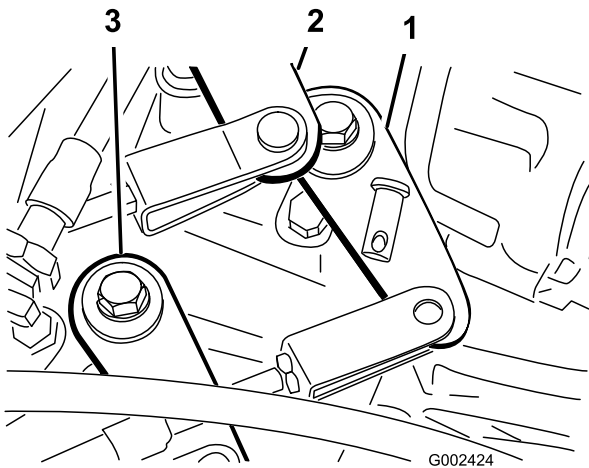

**Figure 52**

1. Shift arm (1st to reverse)
2. Shift arm (2nd to 3rd)
3. Shift arm (High to low)

3. Loosen the clevis jam nuts and adjust each clevis, so that the cable free play is equal forward and backward relative to the hole in the transaxle-shift arm (with the transaxle lever free play taken up in the same direction).
4. Install the clevis pins and tighten the jam nuts when finished.

# Adjusting the High-to-Low Cable

**Service Interval:** Every 200 hours

1. Remove the clevis pin securing the high-to-low cable to the transaxle (Figure 52).
2. Loosen the clevis jam nut and adjust the clevis so that the clevis hole aligns with the hole in the transaxle bracket.
3. Install the clevis pin and tighten the jam nut when finished.

## Adjusting Differential-Lock Cable

**Service Interval:** Every 200 hours

1. Move the differential-lock lever to the OFF position.
2. Loosen the jam nuts securing the differential-lock cable to the bracket on the transaxle (Figure 53).

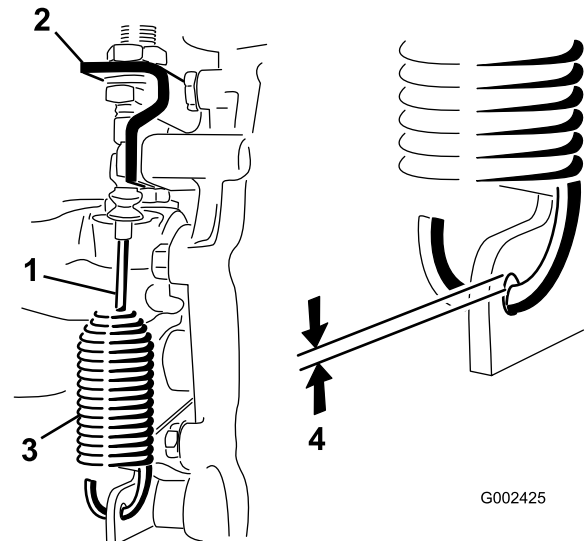

**Figure 53**

1. Differential-lock cable
2. Transaxle bracket
3. Spring
4. 0.25 to 1.5 mm (0.01 to 0.06 inch) gap

3. Adjust the jam nuts to obtain a 0.25 to 1.5 mm (0.01 to 0.06 inch) gap between the spring hook and the OD of the hole in the transaxle lever.
4. Tighten the jam nuts when finished.

# Inspecting the Tires

**Service Interval:** Every 100 hours

The air pressure in the front tires should be 220 kPa (32 psi) and the rear tires should be 124 kPa (18 psi).

Operating accidents, such as hitting curbs, can damage a tire or rim and also disrupt wheel alignment, so inspect the tire condition after an accident.

**Important:** Check the tire pressure frequently to ensure proper inflation. If the tires are not inflated to the correct pressure, the tires will wear prematurely and may cause 4-wheel drive to bind.

Figure 54 is an example of tire wear caused by under inflation.

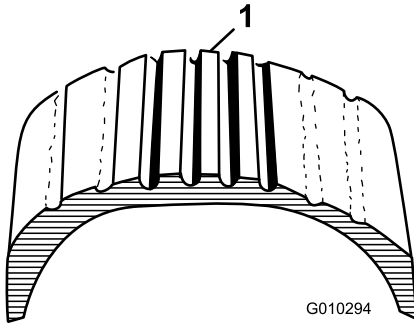

**Figure 54**

1. Under-inflated tire

Figure 55 is an example of tire wear caused by over inflation.

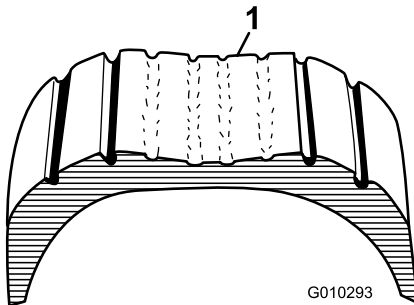

**Figure 55**

1. Over-inflated tire

# Checking the Front-Wheel Alignment

**Service Interval:** Every 400 hours/Yearly (whichever comes first)

1. Make sure that the tires are facing straight ahead.
2. Measure the center-to-center distance (at axle height) at the front and rear of the steering tires (Figure 56).

**Note:** The measurement must be within  $0 \pm 3$  mm ( $0 \pm 0.12$  inch) at the front of the tire then at the rear of the tire. Rotate the tire  $90^\circ$  and check the measurement.

**Important:** Check the measurements at consistent locations on the tire. The machine should be on a flat surface with the tires facing straight ahead.

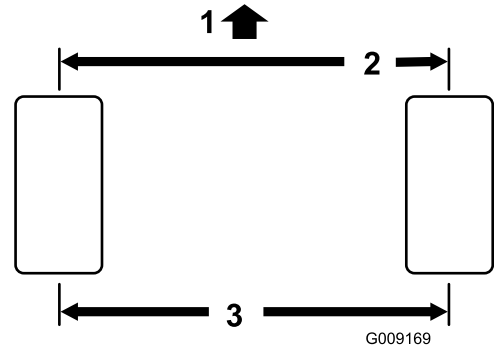
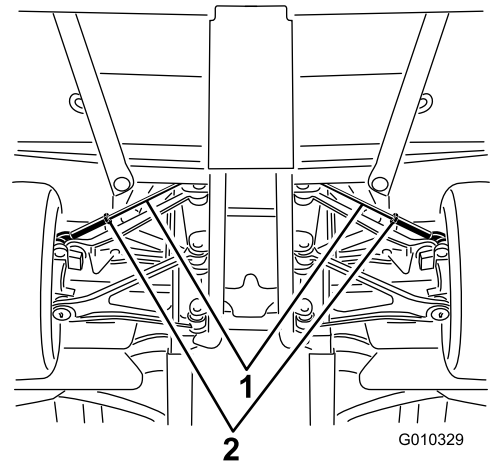

**Figure 56**

1. Front of the machine
2.  $0 \pm 3$  mm ( $0 \pm 0.12$  inch) front to rear of the tire
3. Center to center distance

3. Adjust the center-to-center distance as follows:

- A. Loosen the jam nut at the center of the tie rod (Figure 57).



**Figure 57**

1. Tie rods
2. Jam nuts

- B. Rotate the tie rod to move the front of the tire inward or outward to achieve the center to center distances from front to back.
- C. Tighten the tie rod jam nut when the adjustment is correct.
- D. Check to ensure that the tires turn an equal amount to the right and to the left.

**Note:** If the tires do not turn equally, refer to the *Service Manual* for the adjustment procedure.

# Cooling System Maintenance

## Removing Debris from the Cooling System

**Service Interval:** Before each use or daily (clean more frequently in dirty conditions).

1. Turn the engine off and clean the engine area thoroughly of all debris.
2. Unlatch and remove the radiator screen from the front of the radiator (Figure 58).

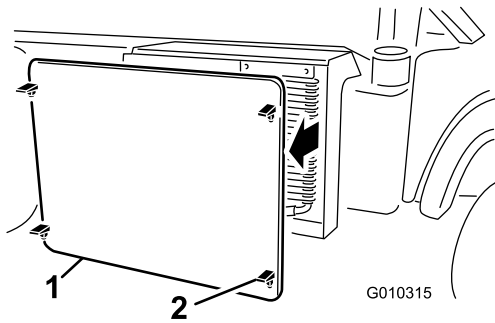

Figure 58

1. Radiator screen
2. Latch

3. If so equipped, rotate the latches and pivot the oil cooler away from the radiator (Figure 59).

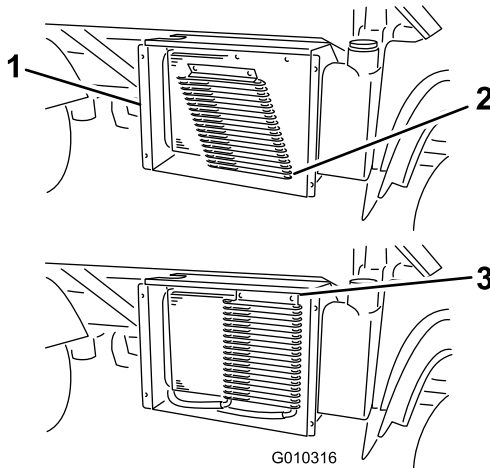

Figure 59

1. Radiator housing
2. Oil cooler
3. Latches

4. Clean the radiator, oil cooler, and screen thoroughly with compressed air.

**Note:** Blow debris away from the radiator. Do not use water to clean external surfaces of the radiator.

5. Install the cooler and screen to the radiator.

## Changing the Engine Coolant

**Service Interval:** Every 1,000 hours/Every 2 years (whichever comes first)

**Coolant type:** 50/50 mixture of water and permanent ethylene-glycol antifreeze

**Note:** Multiple cycles of the following procedure may be required to properly flush and change the engine coolant.

1. Park the machine on a level surface.
2. Raise the bed (if so equipped) and place the safety support on the extended-lift cylinder to hold up the bed.

### CAUTION

If the engine has been running, the pressurized, hot coolant can escape and cause burns.

- Do not open the reserve tank cap when the engine is running.
- Allow engine to cool at least 15 minutes or until the reserve tank cap is cool enough to touch without burning your hand.
- Use a rag when opening the reserve tank cap, and open the cap slowly to allow steam to escape.

3. Remove the radiator cap.

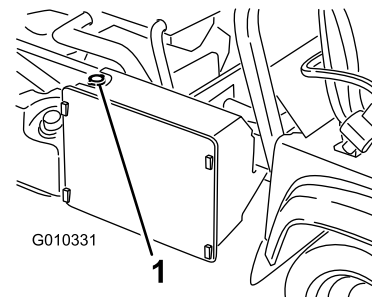

Figure 60

1. Radiator cap

4. Remove the reserve-tank cap (Figure 61).



# Brake Maintenance

## Adjusting the Parking Brake

**Service Interval:** After the first 10 hours

Every 200 hours

1. Remove the rubber grip from the parking-brake lever (Figure 62).

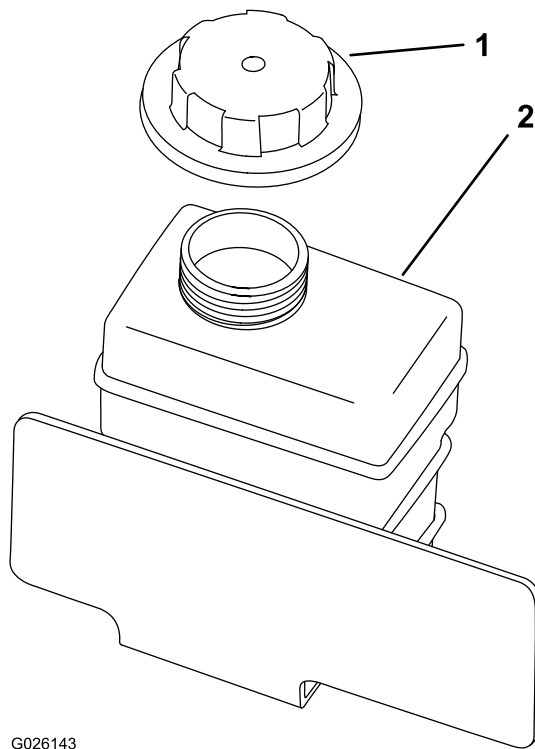

G026143

**Figure 61**

1. Reserve tank-cap
2. Reserve tank

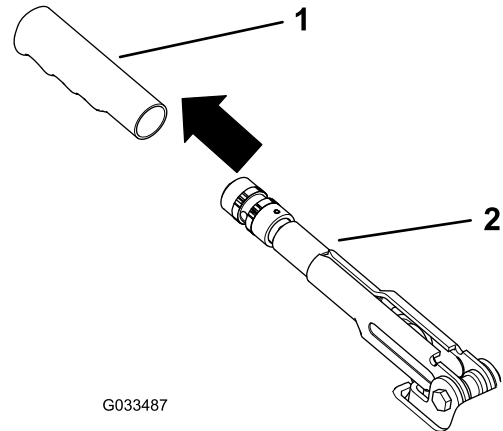

G033487

**Figure 62**

1. Grip
2. Parking-brake lever

5. Disconnect the lower radiator hose and allow coolant to flow into a drain pan.
6. When coolant stops, connect the lower radiator hose.
7. Remove the coolant-drain plug from the engine and allow coolant to flow into a drain pan.
8. When coolant stops, install the drain plug.
9. Slowly fill the radiator with a 50/50 mixture of water and permanent ethylene-glycol antifreeze.
10. Install the radiator cap.
11. Fill the reservoir tank to the bottom of the filler neck.
12. Start the engine and allow it to idle.
13. As air escapes, fill the reservoir to the bottom of the filler neck.

**Note:** Do not allow the engine to heat up to the running temperature.

14. Install the reserve-tank cap.
15. Run the machine until it reaches the operating temperature.
16. Turn off the machine and allow it to cool.
17. Check the coolant level again, and replenish it, if required.

2. Loosen the set screw securing the knob to the parking-brake lever (Figure 63).

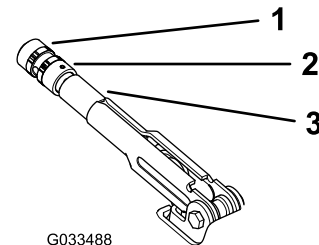

G033488

**Figure 63**

1. Knob
2. Set screw
3. Parking-brake lever

3. Rotate the knob until a force of 20 to 22 kg (45 to 50 lb) is required to actuate the lever.
4. Tighten the set screw when finished.

**Note:** If no adjustment is left at the handle, loosen the handle to the middle of the adjustment and adjust the cable at the rear, then repeat step 3.

5. Install the rubber grip onto the parking-brake lever.

# Adjusting the Brake Pedal

**Service Interval:** Every 200 hours

**Note:** Remove the front hood to ease the adjustment procedure.

1. Remove the cotter pin and clevis pin securing the master cylinder yoke to the brake-pedal pivot (Figure 64).

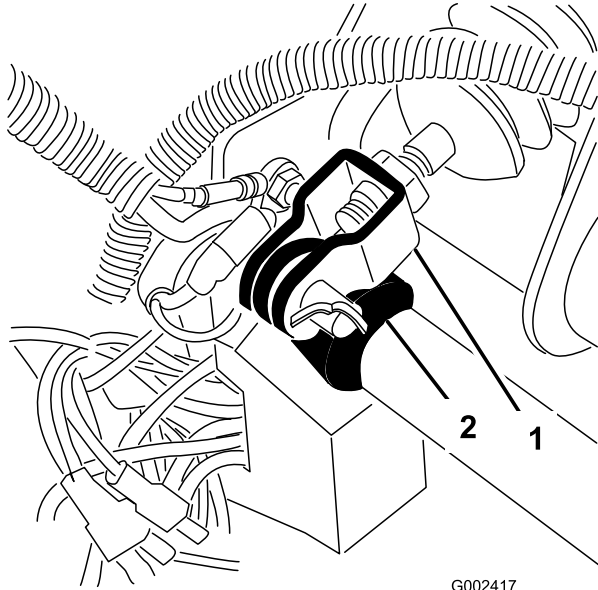

**Figure 64**

1. Master cylinder yoke
2. Brake-pedal pivot

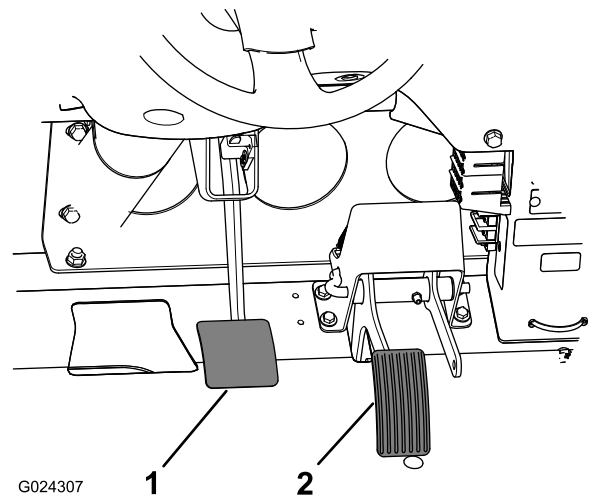

**Figure 65**

1. Brake pedal
2. Accelerator pedal

2. Lift up on the brake pedal (Figure 65) until it contacts the frame.
3. Loosen the jam nuts securing the yoke to the master cylinder shaft (Figure 65).
4. Adjust the yoke until its holes align with the hole in the brake-pedal pivot.
5. Secure the yoke to the pedal pivot with the clevis pin and cotter pin.
6. Tighten the jam nuts securing the yoke to the master cylinder shaft.

**Note:** The brake master cylinder must relieve pressure when properly adjusted.

# Belt Maintenance

## Adjusting the Alternator Belt

**Service Interval:** After the first 8 hours—Check the condition and tension of the alternator belt.

Every 200 hours—Check the condition and tension of the alternator belt.

1. Raise the bed (if equipped) and position the safety support on the extended-lift cylinder to hold up the bed.
2. Check the tension by pressing the belt at mid span between the crankshaft and alternator pulleys with 10 kg (22 lb) of force (Figure 66).

**Note:** A new belt should deflect 8 to 12 mm (0.3 to 0.5 inch).

**Note:** A used belt should deflect 10 to 14 mm (0.4 to 0.55 inch). If the deflection is incorrect, proceed to the next step. If correct, continue operation.

3. To adjust the belt tension, complete the following:
  - A. Loosen the 2 alternator-mounting bolts (Figure 66).

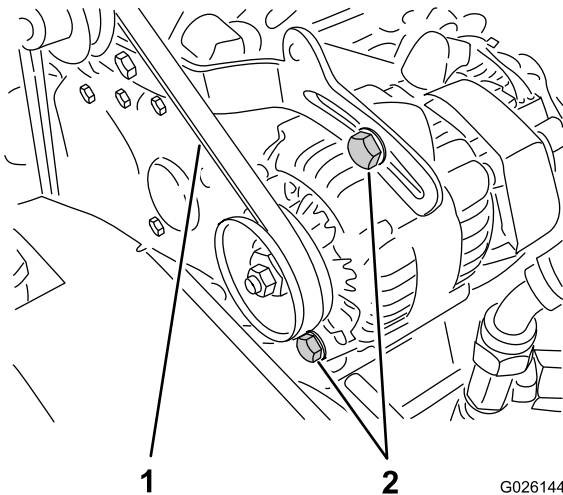

Figure 66

1. Alternator belt
2. Alternator-mounting bolts

- B. Using a pry bar, rotate the alternator until the proper belt tension is attained, then tighten the mounting bolts (Figure 66).

# Controls System Maintenance

## Adjusting the Accelerator Pedal

1. Position the machine on a level surface, shut off the engine, and engage the parking brake.
2. Adjust the ball joint on the accelerator cable (Figure 67) to allow 2.54 to 6.35 mm (0.100 to 0.250 inch) of clearance between the accelerator-pedal arm and the top of the diamond tread floor plate (Figure 68), when a 11.3 kg (25 lb) force is applied to the center of the pedal.

**Note:** The engine must not be running and the return spring must be attached.

3. Tighten the locknut (Figure 67).

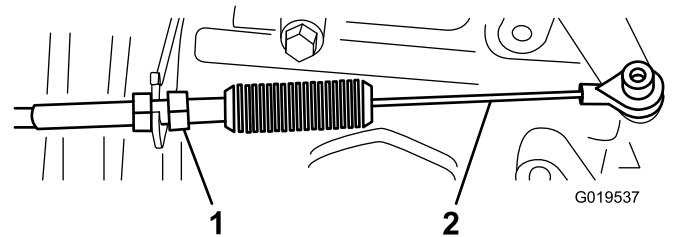

Figure 67

1. Locknut
2. Accelerator cable

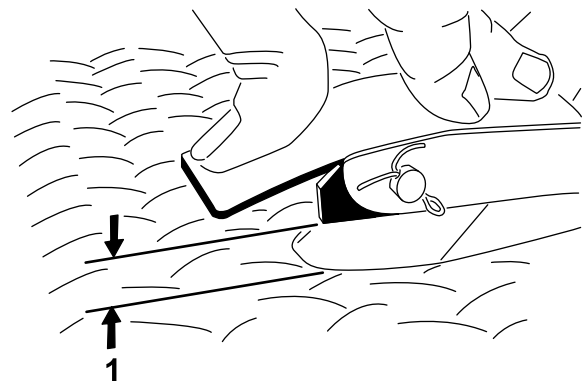

Figure 68

1. 2.54 to 6.35 mm (0.100 to 0.250 inch) clearance

**Important:** The maximum high-idle speed is 3,650 rpm. The high-idle stop should not be adjusted.

# Adjusting the Clutch Pedal

**Service Interval:** Every 200 hours

**Note:** You can adjust the clutch-pedal cable at the bell housing or at the clutch-pedal pivot. The front hood can be removed to ease the access to the pedal pivot.

1. Loosen the jam nuts securing the clutch cable to the bracket on the bell housing (Figure 69).

**Note:** You may remove and rotate the ball joint if additional adjustment is required.

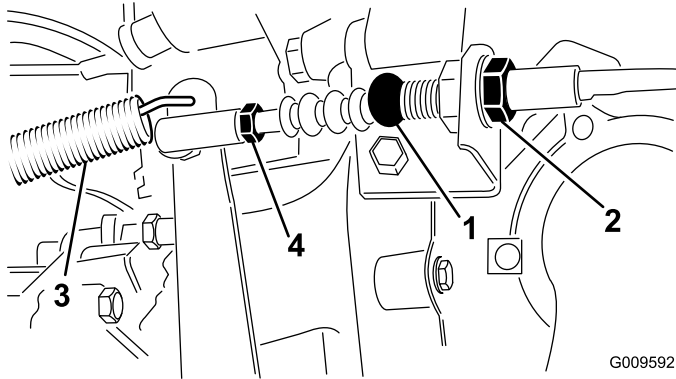

**Figure 69**

- |                 |                  |
|-----------------|------------------|
| 1. Clutch cable | 3. Return spring |
| 2. Jam nuts     | 4. Ball joint    |

**Note:** Adjust again if it is necessary.

6. Connect the return spring to the clutch lever.

**Important:** Ensure that the rod end is positioned squarely on the ball, not twisted, and remains parallel to the clutch pedal after the jam nut is tightened (Figure 71).

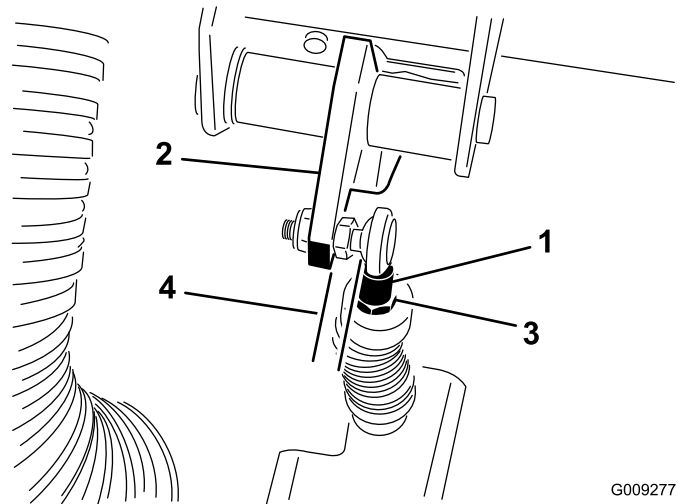

**Figure 71**

- |                         |                    |
|-------------------------|--------------------|
| 1. Clutch-cable rod end | 3. Rod end jam nut |
| 2. Clutch pedal         | 4. Parallel        |

2. Disconnect the return spring from the clutch lever.
3. Adjust the jam nuts or ball joint until the rear edge of the clutch pedal is 9.2 to 9.8 cm (3-5/8 to 3-7/8 inches) from the top of the floor plate diamond pattern, when an 1.8 kg (4 lb) force is applied to the pedal (Figure 70).

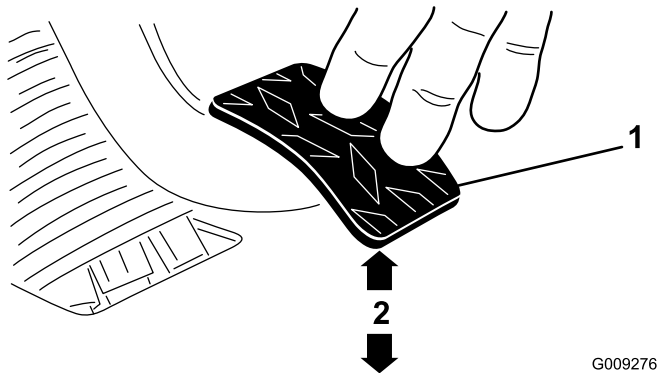

**Figure 70**

- |                 |  |
|-----------------|--|
| 1. Clutch pedal | 2. 9.2 to 9.8 cm (3.63 to 3.87 inches) |
|-----------------|--|

**Note:** The clutch free play should never be less than 19 mm (3/4 inch).

## Converting the Speedometer

You can convert the speedometer from mph to km/h or km/h to mph.

1. Position the machine on a level surface, shut off the engine, engage the parking brake, and remove the key from the ignition switch.
2. Remove the hood; refer to [Removing the Hood \(page 38\)](#).
3. Locate the 2 loose wires next to the speedometer.
4. Remove the connector plug from the harness wire and connect the wires together.

**Note:** The speedometer switches to km/h or mph.

5. Install the hood.

**Note:** Force is applied so the clutch release bearing lightly contacts the pressure plate fingers.

4. Tighten the jam nuts after the adjustment has been attained.
5. Check the 9.2 to 9.8 cm (3-5/8 to 3-7/8 inches) dimension after the jam nuts have been tightened to ensure proper adjustment.

# Hydraulic System Maintenance

## Changing the Hydraulic Fluid and Cleaning the Strainer

**Service Interval:** Every 800 hours

**Hydraulic-fluid capacity:** 7 L (7.5 US qt)

**Hydraulic-fluid type:** Dexron III ATF

1. Position the machine on a level surface, shut off the engine, engage the parking brake, and remove the key from the ignition switch.
2. Remove the drain plug from the side of the reservoir, and let the hydraulic fluid flow into a drain pan (Figure 72).

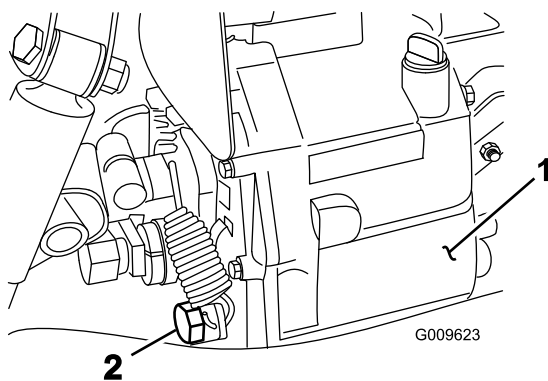

1. Hydraulic reservoir
2. Drain plug

3. Note the orientation of the hydraulic hose and 90° fitting connected to the strainer on the side of the reservoir (Figure 73).
4. Remove the hydraulic hose and 90° fitting.
5. Remove the strainer and clean it by back flushing it with a clean de-greaser.

**Note:** Allow it to air dry before installing.

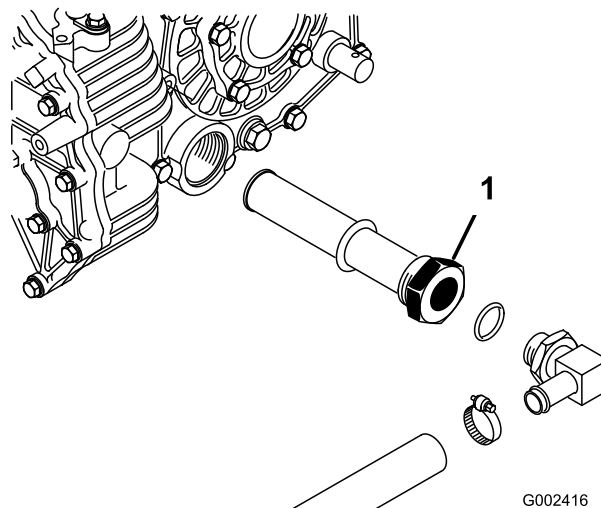

**Figure 73**

1. Hydraulic strainer
6. Install the strainer.
7. Install the hydraulic hose and 90° fitting to the strainer in the same orientation.
8. Install and tighten the drain plug.
9. Fill the reservoir with approximately 7 L (7.5 US qt) of the specified hydraulic fluid; refer to [Checking the Transaxle/Hydraulic-Fluid Level](#) (page 23).
10. Start the engine and operate the machine to fill the hydraulic system.
11. Check the hydraulic-fluid level and replenish it, if required.

**Important:** Use only the hydraulic fluid specified. Other fluids could cause system damage.

## Replacing the Hydraulic Filter

**Service Interval:** After the first 10 hours

Every 800 hours

**Important:** Use of any other filter may void the warranty on some components.

1. Position the machine on a level surface, shut off the engine, engage the parking brake, and remove the key from ignition switch.
2. Clean the area around the filter-mounting area.
3. Place a drain pan under the filter and remove the filter (Figure 74).

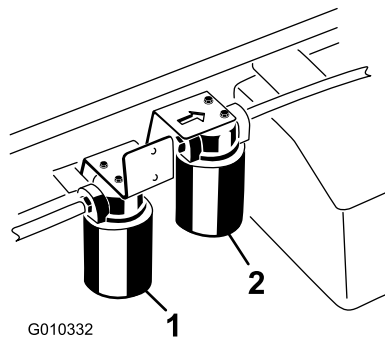

Figure 74

1. Hydraulic filter
2. High-flow hydraulic filter

4. Lubricate the gasket on the new filter.
5. Ensure that the filter mounting area is clean.
6. Screw the filter on until the gasket contacts the mounting plate, and tighten the filter 1/2 turn.
7. Start the engine and let it run for about 2 minutes to purge air from the system.
8. Shut off the engine and check the hydraulic-fluid level and for leaks.

## Changing the High-Flow Hydraulic Fluid and Filter

### TC Models Only

**Service Interval:** After the first 10 hours—Change the high-flow hydraulic fluid filter (TC models only).

Every 800 hours—Change the high-flow hydraulic fluid and filter (TC models only).

**Hydraulic-fluid capacity:** approximately 15 L (4 US gallons)

**Hydraulic-fluid type:** Toro Premium All Season Hydraulic Fluid (Available in 5 gallon pails or 55 gallon drums. See parts catalog or Toro distributor for part numbers.)

**Alternate fluids:** If the Toro fluid is not available, another conventional petroleum-based fluid may be used provided it meets the following material properties and industry specifications. Consult with your lubricant distributor to identify a satisfactory product.

**Note:** Toro will not assume responsibility for damage caused by improper substitutions, so use only products from reputable manufacturers who will stand behind their recommendation.

**High Viscosity Index/Low Pour Point Antiwear Hydraulic Fluid, ISO VG 46**

#### Material Properties:

- Viscosity—ASTM D445 cSt @ 40°C: 44 to 48/cSt @ 100°C: 7.9 to 8.5

- Viscosity Index, ASTM D2270—140 to 152
- Pour Point, ASTM D97— -35°F to -46°F
- FZG, Fail stage—11 or better
- Water content (new fluid)—500 ppm (maximum)

#### Industry Specifications:

Vickers I-286-S, Vickers M-2950-S, Denison HF-0, Vickers 35 VQ 25 (Eaton ATS373-C)

**Note:** Many hydraulic fluids are almost colorless, making it difficult to spot leaks. A red dye additive for the hydraulic system fluid is available in 20 ml (0.67 oz.) bottles. A bottle is sufficient for 15 to 22 L (4 to 6 US gallons) of hydraulic fluid. Order Part No. 44-2500 from your authorized Toro distributor.

**Note:** If the fluid becomes contaminated, contact your local Toro distributor because the system must be flushed. Contaminated fluid may look milky or black when compared to clean fluid. The service interval may need to be increased if using multiple attachments as the fluid may become contaminated quicker with the mixing of different hydraulic fluids.

1. Clean the area around the high-flow-filter mounting area (Figure 74).
2. Place a drain pan under the filter and remove the filter.

**Note:** If the fluid is not going to be drained, disconnect and plug the hydraulic line going to the filter.

3. Lubricate the new filter-sealing gasket and hand turn the filter onto the filter head until the gasket contacts the filter head. Then tighten it 3/4 turn further. The filter should now be sealed.
4. Fill the hydraulic reservoir with approximately 15 L (4 US gallons) of hydraulic fluid.
5. Start the machine and run it at idle for about 2 minutes to circulate the fluid and remove any air trapped in the system.
6. Stop the machine and check the fluid level.
7. Verify the fluid level.
8. Dispose of the fluid properly.

## Raising the Cargo Box in an Emergency

The cargo box can be raised in an emergency without starting the engine by cranking starter or by jumping hydraulic system.

### Raising the Cargo Box using the Starter

Crank the starter while holding the lift lever in the Raise position. Run the starter for 10 seconds, then wait 60 seconds before engaging the starter again. If the engine will not crank,

you must remove the load and box (attachment) to service the engine or transaxle.

## Raising the Cargo Box by Jumping the Hydraulic System

### ⚠ CAUTION

A raised bed full of material without the proper safety support rod may lower unexpectedly. Working under an unsupported raised bed may cause injury to you or others.

- Before servicing or making adjustments to the machine, shut off the engine, set the parking brake, and remove the key from the ignition switch.
- Remove any load material from the bed or other attachment and insert the safety support on a fully extended cylinder rod before working under a raised bed.

You will need 2 hydraulic hoses, each with a male and female quick coupler, that fit the vehicle couplers, to perform this operation.

1. Back another machine up to the rear of the disabled machine.

**Important:** The machine hydraulic system uses Dexron III ATF. To avoid system contamination, make sure that the vehicle used to jump the hydraulic system uses an equivalent fluid.

2. On both machine, disconnect the 2 quick-coupler hoses from the hoses secured to the coupler bracket (Figure 75).

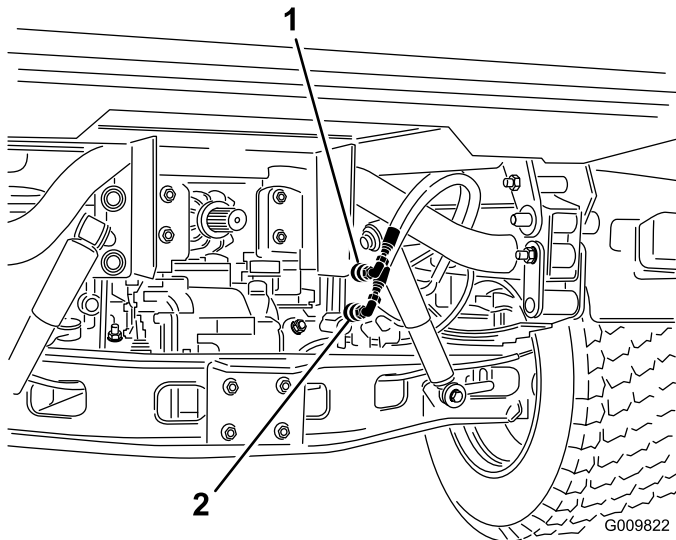

Figure 75

1. Quick-coupler hose A
2. Quick-coupler hose B

3. On the disabled machine, connect the 2 jumper hoses to the hoses that were disconnected (Figure 76).
4. Cap the unused fittings.

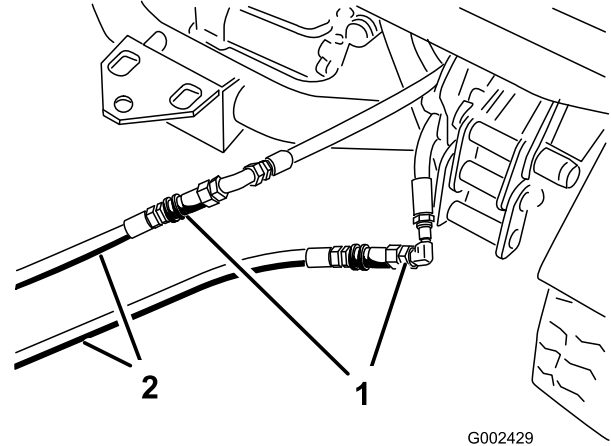

Figure 76

1. Disconnected hoses
2. Jumper hoses

5. On the other machine, connect the 2 hoses to the coupler still in the coupler bracket (connect the top hose to the top coupler and the bottom hose to the bottom coupler) (Figure 77).
6. Cap the unused fittings.

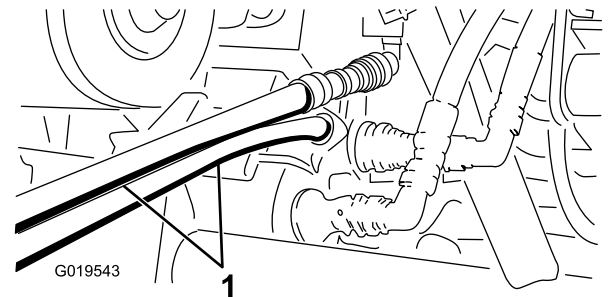

Figure 77

1. Jumper hoses

7. Keep all bystanders away from the machines.
8. Start the second machine, and move the lift lever to the raise position which will raise the disabled cargo box.
9. Move the hydraulic-lift lever to the NEUTRAL position, and engage the lift-lever lock.
10. Install the bed support onto the extended lift cylinder; refer to Using the Bed Support (page 35).

**Note:** With both the machine turned off, move the lift lever back and forth to remove the system pressure and ease the disconnection of the quick couplers.

11. After completing the operation, remove the jumper hoses and connect the hydraulic hoses to both machines.

**Important:** Check the hydraulic fluid levels, in both vehicles, before resuming operation.

# Cleaning

## Washing the Machine

Wash the machine as needed. Use water alone or with a mild detergent. You may use a rag when washing the machine; however, the hood will lose some of its luster.

**Important:** Do not use power-washing equipment to wash the machine. Power-washing equipment may damage the electrical system, loosen important decals, or wash away necessary grease at friction points. Avoid excessive use of water near the control panel, engine, and battery.

**Important:** Do not wash the machine with the engine running. Washing the machine with the engine running may result in internal engine damage.

# Storage

1. Position the machine on a level surface, set the parking brake, stop the engine, and remove the starter key.
2. Clean dirt and grime from the entire machine, including the outside of the engine cylinder head fins and blower housing.  
**Important:** You can wash the machine with mild detergent and water. Do not use high-pressure water to wash the machine. Pressure washing may damage the electrical system or wash away necessary grease at friction points. Avoid excessive use of water, especially near the control panel, lights, engine, and the battery.
3. Inspect the brakes; refer to [Checking the Brake-Fluid Level \(page 25\)](#).
4. Service the air cleaner; refer to [Servicing the Air Cleaner \(page 41\)](#).
5. Seal the air cleaner inlet and the exhaust outlet with weatherproof tape.
6. Grease the machine; refer to [Greasing the Bearings and Bushings \(page 39\)](#).
7. Change the engine oil and filter; refer to [Changing the Engine Oil and Filter \(page 41\)](#).
8. Flush the fuel tank with fresh, clean diesel fuel.
9. Secure all fuel system fittings.
10. Check the tire pressure; refer to [Checking the Tire Pressure \(page 25\)](#).
11. Check anti freeze protection and add a 50/50 solution of water and anti freeze as needed for expected minimum temperature in your area.
12. Remove the battery from the chassis, check the electrolyte level, and charge it fully; refer to [Servicing the Battery \(page 45\)](#).

**Note:** Do not connect the battery cables to the battery posts during storage.

**Important:** The battery must be fully charged to prevent it from freezing and being damaged at temperatures below 0°C (32°F). A fully charged battery maintains its charge for about 50 days at temperatures lower than 4°C (40°F). If the temperatures will be above 4°C (40°F), check the water level in the battery and charge it every 30 days.

13. Check and tighten all bolts, nuts, and screws. Repair or replace any part that is damaged.
14. Paint all scratched or bare metal surfaces.  
Paint is available from your Authorized Toro Service Dealer.
15. Store the machine in a clean, dry garage or storage area.
16. Cover the machine to protect it and keep it clean.



**Notes:**

**Notes:**

## International Distributor List

<b>Distributor:</b>	<b>Country:</b>	<b>Phone Number:</b>	<b>Distributor:</b>	<b>Country:</b>	<b>Phone Number:</b>
Agrolanc Kft	Hungary	36 27 539 640	Maquiver S.A.	Colombia	57 1 236 4079
Asian American Industrial (AAI)	Hong Kong	852 2497 7804	Maruyama Mfg. Co. Inc.	Japan	81 3 3252 2285
B-Ray Corporation	Korea	82 32 551 2076	Mountfield a.s.	Czech Republic	420 255 704 220
Brisa Goods LLC	Mexico	1 210 495 2417	Mountfield a.s.	Slovakia	420 255 704 220
Casco Sales Company	Puerto Rico	787 788 8383	Munditol S.A.	Argentina	54 11 4 821 9999
Ceres S.A.	Costa Rica	506 239 1138	Norma Garden	Russia	7 495 411 61 20
CSSC Turf Equipment (pvt) Ltd.	Sri Lanka	94 11 2746100	Oslinger Turf Equipment SA	Ecuador	593 4 239 6970
Cyril Johnston & Co.	Northern Ireland	44 2890 813 121	Oy Hako Ground and Garden Ab	Finland	358 987 00733
Cyril Johnston & Co.	Republic of Ireland	44 2890 813 121	Parkland Products Ltd.	New Zealand	64 3 34 93760
Fat Dragon	China	886 10 80841322	Perfetto	Poland	48 61 8 208 416
Femco S.A.	Guatemala	502 442 3277	Pratoverde SRL.	Italy	39 049 9128 128
FIVEMANS New-Tech Co., Ltd	China	86-10-6381 6136	Prochaska & Cie	Austria	43 1 278 5100
ForGarder OU	Estonia	372 384 6060	RT Cohen 2004 Ltd.	Israel	972 986 17979
G.Y.K. Company Ltd.	Japan	81 726 325 861	Riversa	Spain	34 9 52 83 7500
Geomechaniki of Athens	Greece	30 10 935 0054	Lely Turfcare	Denmark	45 66 109 200
Golf international Turizm	Turkey	90 216 336 5993	Lely (U.K.) Limited	United Kingdom	44 1480 226 800
Hako Ground and Garden	Sweden	46 35 10 0000	Solvart S.A.S.	France	33 1 30 81 77 00
Hako Ground and Garden	Norway	47 22 90 7760	Spypros Stavrinides Limited	Cyprus	357 22 434131
Hayter Limited (U.K.)	United Kingdom	44 1279 723 444	Surge Systems India Limited	India	91 1 292299901
Hydroturf Int. Co Dubai	United Arab Emirates	97 14 347 9479	T-Markt Logistics Ltd.	Hungary	36 26 525 500
Hydroturf Egypt LLC	Egypt	202 519 4308	Toro Australia	Australia	61 3 9580 7355
Irrimac	Portugal	351 21 238 8260	Toro Europe NV	Belgium	32 14 562 960
Irrigation Products Int'l Pvt Ltd.	India	0091 44 2449 4387	Valtech	Morocco	212 5 3766 3636
Jean Heybroek b.v.	Netherlands	31 30 639 4611	Victus Emak	Poland	48 61 823 8369

### European Privacy Notice

#### The Information Toro Collects

Toro Warranty Company (Toro) respects your privacy. In order to process your warranty claim and contact you in the event of a product recall, we ask you to share certain personal information with us, either directly or through your local Toro company or dealer.

The Toro warranty system is hosted on servers located within the United States where privacy law may not provide the same protection as applies in your country.

BY SHARING YOUR PERSONAL INFORMATION WITH US, YOU ARE CONSENTING TO THE PROCESSING OF YOUR PERSONAL INFORMATION AS DESCRIBED IN THIS PRIVACY NOTICE.

#### The Way Toro Uses Information

Toro may use your personal information to process warranty claims, to contact you in the event of a product recall and for any other purpose which we tell you about. Toro may share your information with Toro's affiliates, dealers or other business partners in connection with any of these activities. We will not sell your personal information to any other company. We reserve the right to disclose personal information in order to comply with applicable laws and with requests by the appropriate authorities, to operate our systems properly or for our own protection or that of other users.

#### Retention of your Personal Information

We will keep your personal information as long as we need it for the purposes for which it was originally collected or for other legitimate purposes (such as regulatory compliance), or as required by applicable law.

#### Toro's Commitment to Security of Your Personal Information

We take reasonable precautions in order to protect the security of your personal information. We also take steps to maintain the accuracy and current status of personal information.

#### Access and Correction of your Personal Information

If you would like to review or correct your personal information, please contact us by email at [legal@toro.com](mailto:legal@toro.com).

### Australian Consumer Law

Australian customers will find details relating to the Australian Consumer Law either inside the box or at your local Toro Dealer.



# The Toro Warranty

## A Two-Year Limited Warranty

### Conditions and Products Covered

The Toro Company and its affiliate, Toro Warranty Company, pursuant to an agreement between them, jointly warrant your Toro Commercial product ("Product") to be free from defects in materials or workmanship for two years or 1500 operational hours\*, whichever occurs first. This warranty is applicable to all products with the exception of Aerators (refer to separate warranty statements for these products). Where a warrantable condition exists, we will repair the Product at no cost to you including diagnostics, labor, parts, and transportation. This warranty begins on the date the Product is delivered to the original retail purchaser.

\* Product equipped with an hour meter.

### Instructions for Obtaining Warranty Service

You are responsible for notifying the Commercial Products Distributor or Authorized Commercial Products Dealer from whom you purchased the Product as soon as you believe a warrantable condition exists. If you need help locating a Commercial Products Distributor or Authorized Dealer, or if you have questions regarding your warranty rights or responsibilities, you may contact us at:

Toro Commercial Products Service Department  
Toro Warranty Company  
8111 Lyndale Avenue South  
Bloomington, MN 55420-1196  
952-888-8801 or 800-952-2740  
E-mail: commercial.warranty@toro.com

### Owner Responsibilities

As the Product owner, you are responsible for required maintenance and adjustments stated in your *Operator's Manual*. Failure to perform required maintenance and adjustments can be grounds for disallowing a warranty claim.

### Items and Conditions Not Covered

Not all product failures or malfunctions that occur during the warranty period are defects in materials or workmanship. This warranty does not cover the following:

- Product failures which result from the use of non-Toro replacement parts, or from installation and use of add-on, or modified non-Toro branded accessories and products. A separate warranty may be provided by the manufacturer of these items.
- Product failures which result from failure to perform recommended maintenance and/or adjustments. Failure to properly maintain your Toro product per the Recommended Maintenance listed in the *Operator's Manual* can result in claims for warranty being denied.
- Product failures which result from operating the Product in an abusive, negligent, or reckless manner.
- Parts subject to consumption through use unless found to be defective. Examples of parts which are consumed, or used up, during normal Product operation include, but are not limited to, brake pads and linings, clutch linings, blades, reels, rollers and bearings (sealed or greasable), bed knives, spark plugs, castor wheels and bearings, tires, filters, belts, and certain sprayer components such as diaphragms, nozzles, and check valves, etc.
- Failures caused by outside influence. Conditions considered to be outside influence include, but are not limited to, weather, storage practices, contamination, use of unapproved fuels, coolants, lubricants, additives, fertilizers, water, or chemicals, etc.
- Failure or performance issues due to the use of fuels (e.g. gasoline, diesel, or biodiesel) that do not conform to their respective industry standards.

### Countries Other than the United States or Canada

Customers who have purchased Toro products exported from the United States or Canada should contact their Toro Distributor (Dealer) to obtain guarantee policies for your country, province, or state. If for any reason you are dissatisfied with your Distributor's service or have difficulty obtaining guarantee information, contact the Toro importer.

- Normal noise, vibration, wear and tear, and deterioration.
- Normal "wear and tear" includes, but is not limited to, damage to seats due to wear or abrasion, worn painted surfaces, scratched decals or windows, etc.

### Parts

Parts scheduled for replacement as required maintenance are warranted for the period of time up to the scheduled replacement time for that part. Parts replaced under this warranty are covered for the duration of the original product warranty and become the property of Toro. Toro will make the final decision whether to repair any existing part or assembly or replace it. Toro may use remanufactured parts for warranty repairs.

### Deep Cycle and Lithium-Ion Battery Warranty:

Deep cycle and Lithium-Ion batteries have a specified total number of kilowatt-hours they can deliver during their lifetime. Operating, recharging, and maintenance techniques can extend or reduce total battery life. As the batteries in this product are consumed, the amount of useful work between charging intervals will slowly decrease until the battery is completely worn out. Replacement of worn out batteries, due to normal consumption, is the responsibility of the product owner. Battery replacement may be required during the normal product warranty period at owner's expense. Note: (Lithium-Ion battery only): A Lithium-Ion battery has a part only prorated warranty beginning year 3 through year 5 based on the time in service and kilowatt hours used. Refer to the *Operator's Manual* for additional information.

### Maintenance is at Owner's Expense

Engine tune-up, lubrication, cleaning and polishing, replacement of filters, coolant, and completing recommended maintenance are some of the normal services Toro products require that are at the owner's expense.

### General Conditions

Repair by an Authorized Toro Distributor or Dealer is your sole remedy under this warranty.

**Neither The Toro Company nor Toro Warranty Company is liable for indirect, incidental or consequential damages in connection with the use of the Toro Products covered by this warranty, including any cost or expense of providing substitute equipment or service during reasonable periods of malfunction or non-use pending completion of repairs under this warranty. Except for the Emissions warranty referenced below, if applicable, there is no other express warranty. All implied warranties of merchantability and fitness for use are limited to the duration of this express warranty.**

Some states do not allow exclusions of incidental or consequential damages, or limitations on how long an implied warranty lasts, so the above exclusions and limitations may not apply to you. This warranty gives you specific legal rights, and you may also have other rights which vary from state to state.

### Note regarding engine warranty:

The Emissions Control System on your Product may be covered by a separate warranty meeting requirements established by the U.S. Environmental Protection Agency (EPA) and/or the California Air Resources Board (CARB). The hour limitations set forth above do not apply to the Emissions Control System Warranty. Refer to the Engine Emission Control Warranty Statement supplied with your product or contained in the engine manufacturer's documentation for details