



Wheel Horse<sup>®</sup>  
**48" Snow/Dozer  
Blade**

for  
**5xi Lawn and Garden Tractors**  
Model No. 79355 – 8900001 & Up

---

# Operator's Manual

**IMPORTANT:** Read this manual, and **your tractor manual**, carefully. They contain information about your safety and the safety of others. Also become familiar with the controls and their proper use before you operate the product.

# Introduction

We want you to be completely satisfied with your new product, so feel free to contact your local Authorized Service Dealer for help with service, genuine replacement parts, or other information you may require.

Whenever you contact your Authorized Service Dealer or the factory, always know the model and serial numbers of your product. These numbers will help the Service Dealer or Service Representative provide exact information about your specific product. You will find the model and serial number plate located in a unique place on the product as shown below.

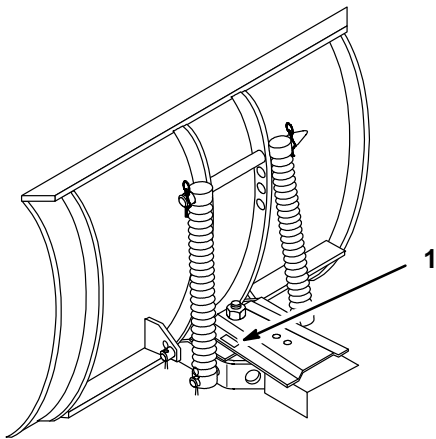

1. Model and Serial Number Plate

For your convenience, write the product model and serial numbers in the space below.

<b>Model No:</b> _____
<b>Serial No.</b> _____

The warning system in this manual identifies potential hazards and has special safety messages that help you and others avoid personal injury, even death. DANGER, WARNING and CAUTION are signal words used to identify the level of hazard. However, regardless of the hazard, be extremely careful.

**DANGER** signals an extreme hazard that will cause serious injury or death if the recommended precautions are not followed.

**WARNING** signals a hazard that may cause serious injury or death if the recommended precautions are not followed.

**CAUTION** signals a hazard that may cause minor or moderate injury if the recommended precautions are not followed.

Two other words are also used to highlight information. “Important” calls attention to special mechanical information and “Note” emphasizes general information worthy of special attention.

The left and right side of the machine is determined by sitting on the seat in the normal operator’s position.

# Contents

	<b>Page</b>		<b>Page</b>
Installation .....	2	Adjusting the Blade Angle .....	10
Loose Parts .....	2	Adjusting the Blade Trip Springs .....	10
Assembling the Blade .....	3	Tips for Using the Blade .....	10
Tractor Set-up .....	4	Maintenance .....	11
Installing the Blade to the Tractor .....	4	Service Interval Chart .....	11
Removing the Blade .....	7	Greasing and Lubrication .....	11
Operation .....	9	Reversing the Scraper Blade .....	12
Attachment Lift Lever .....	9	Storage .....	12

# Installation

## Loose Parts

**Note:** A rear-mount Attach-A-Matic™, which must be purchased separately, is required for this blade. Use the chart below to identify other parts used for assembly.

**Note:** Skids are available for the blade. They can be useful on rough or broken surfaces to keep the blade above the ground. Contact your authorized Toro dealer for more information.

DESCRIPTION	QTY.	USE
Blade assembly	1	Assembling the blade
Rod	1	
Cotter pin 1-1/4" (30 mm)	1	
Frame assembly	1	
Bolt 3/4-16 x 3-3/4" (95 mm)	1	
Lock nut 3/4"	1	
Control handle	1	
Angle control rod	1	
Cable bracket	1	
Cotter pin 1" (25 mm)	3	
Lift link	2	Attaching the center of the blade frame to the tractor
Clevis pin 3/8" x 1" (25 mm)	2	
Clevis pin 3/8" x 3/4" (19 mm)	2	
Hairpin cotter	2	
Cable	1	
Clevis pin 3/8" x 1" (25 mm)	2	Preparing the tractor attachment lift
Hairpin cotter	2	
Operator's Manual	1	Read before operating

## Assembling the Blade

1. Lift and rotate the channel assembly so its holes align with the lower blade mounts. Slide the rod through the holes and secure it with (2) 1" (26 mm) cotter pins (Fig. 1). Bend the ends of the cotter pins to secure the rod.

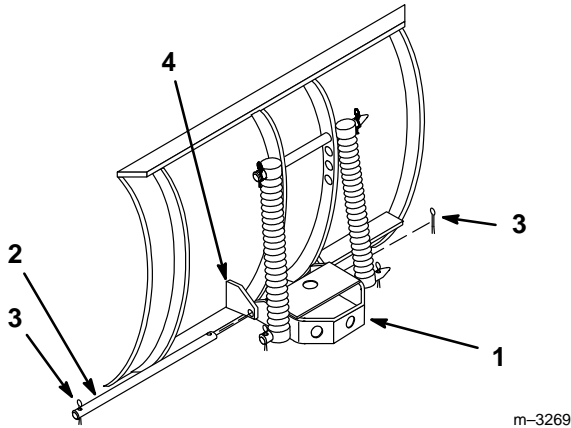

Figure 1

- |                     |                          |
|---------------------|--------------------------|
| 1. Channel assembly | 3. Cotter pin 1" (25 mm) |
| 2. Rod              | 4. Lower blade mounts    |

2. Insert one end of the angle control rod up through the hole in the bottom plate of the channel weldment (Fig. 2). Insert a cotter pin and bend the ends of the pin to secure the rod.

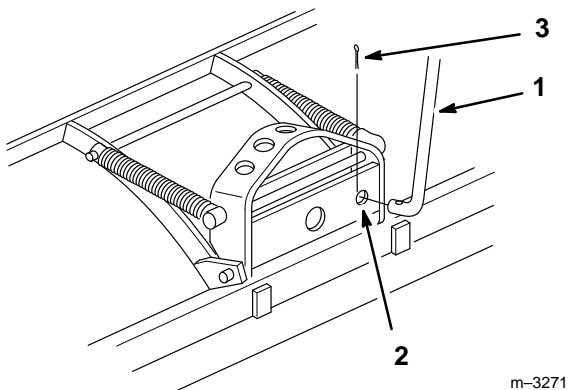

Figure 2

- |                      |                          |
|----------------------|--------------------------|
| 1. Angle control rod | 3. Cotter pin 1" (25 mm) |
| 2. Channel weldment  |                          |

3. Apply general purpose grease to the pivot area of the frame and channel. Slide the channel between the frame mount and secure it with a 3/4-16 x 3-3/4" (95 mm) bolt, down from the top, and 3/4" locknut (Fig. 3).

**IMPORTANT: Do not tighten the nut and bolt excessively, thereby causing binding on the channel weldment as it pivots from side to side.**

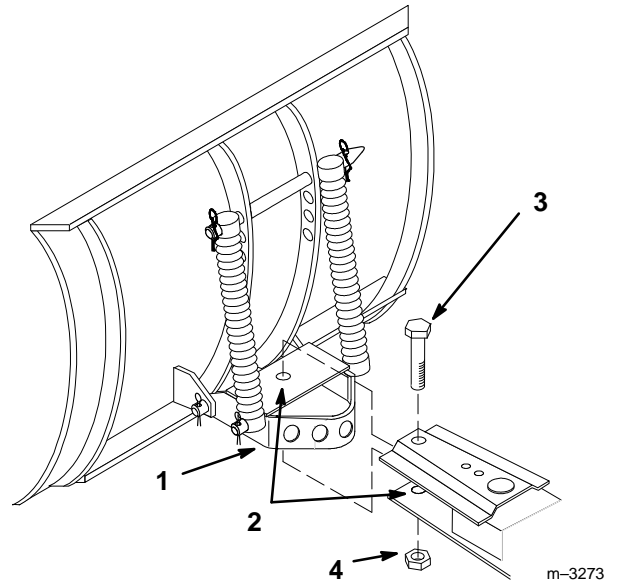

Figure 3

- |                     |                                 |
|---------------------|---------------------------------|
| 1. Channel assembly | 3. Bolt 3/4-16 x 3-3/4" (95 mm) |
| 2. Grease here      | 4. Lock nut 3/4"                |

## Tractor Set-up

### Installing the Rear Attach-A-Matic™ to the Tractor

Follow the installation instructions that come with the rear Attach-A-Matic™ mount.

### Preparing the Tractor's Attachment Lift

1. Start the tractor.
2. Raise the attachment lift.
3. Set the parking brake and turn the ignition key to "OFF" to stop the engine. Remove the ignition key.
4. Install (2) 3/8" x 1" (25 mm) clevis pins into each side of the lift assembly in the positions shown in Figure 4. Secure with (2) hairpin cotters.

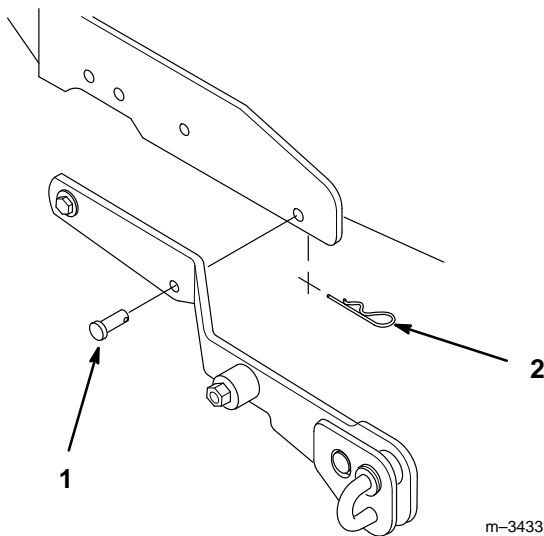

Figure 4

1. Clevis pin 3/8" x 1" (25 mm)
2. Hairpin cotter

These pins must be installed when operating with a blade, snowthrower, or the tiller attachment.

**Note:** The pins are removed to attach a mower.

## Installing the Blade to the Tractor

1. Position the snow blade and its frame on a level surface with space behind the blade assembly to accommodate the tractor.
2. Park the tractor over the snow blade assembly, with the frame between the tractor wheels (Fig. 5). Set the parking brake, lower the attachment lift, and turn the ignition key to "OFF" to stop the engine. Remove the ignition key.

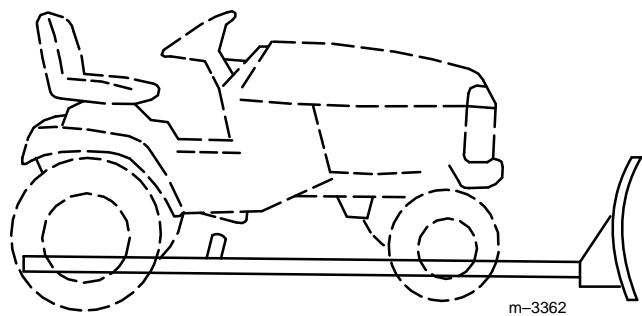
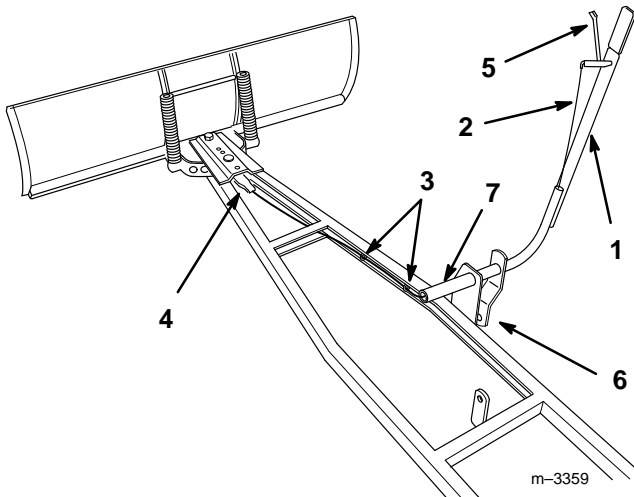

Figure 5

3. Now you will install the control handle (Fig. 6) into the blade frame. Holding the handle in approximately the 9:00 o'clock position, thread the cable through the handle mount in the frame. Then insert the handle into the handle mount. After inserting the handle, rotate it to the 12:00 o'clock position.



**Figure 6**

- |                          |                                       |
|--------------------------|---------------------------------------|
| 1. Control handle        | 5. Release lever                      |
| 2. Cable                 | 6. Connect the angle control rod here |
| 3. Eyelets for the cable | 7. Handle mount                       |
| 4. Cable bracket         |                                       |

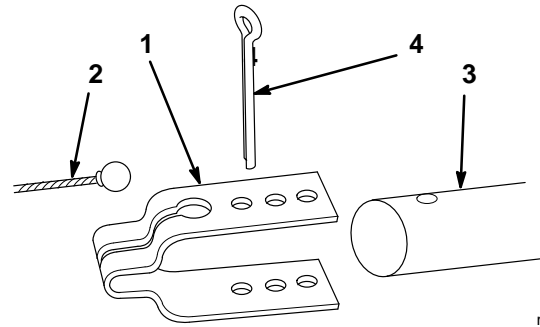
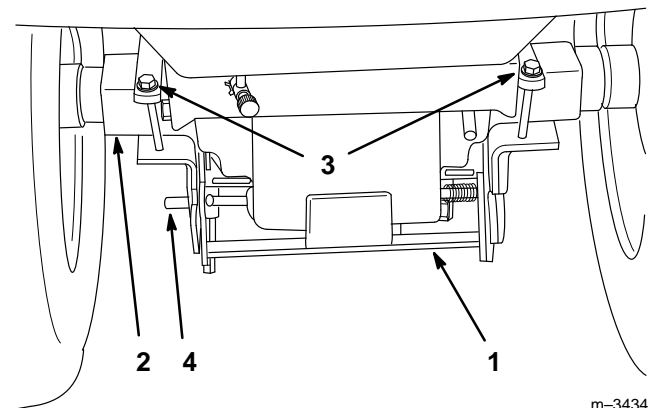

**Figure 7**

- |                  |               |
|------------------|---------------|
| 1. Cable bracket | 3. Angle pin  |
| 2. Cable         | 4. Cotter pin |

4. Insert the angle control rod into the bottom of the control handle, and secure it with a cotter pin.
5. Connect the cable to the release lever.
6. Thread the cable through the two eyelets on the side of the frame, then route it as shown in Figure 6. Insert the cable into the cable bracket, then attach the cable bracket to the angle pin at the blade assembly (Fig. 6 & 7) with a cotter pin. Put the cotter pin through the hole that removes the most slack from the cable. Bend the ends of the cotter pin to retain the cable bracket.

7. Press the release button (Fig. 8) at the Attach-A-Matic™ to open the latches. Place the rear cross-bar of the blade frame into the front two slots of the Attach-A-Matic™. Press on the latches at the rear until they lock the blade frame in place (Fig. 9).



**Figure 8**

- |                    |                   |
|--------------------|-------------------|
| 1. Attach-A-Matic™ | 3. Mounting bolts |
| 2. Axle housing    | 4. Release button |

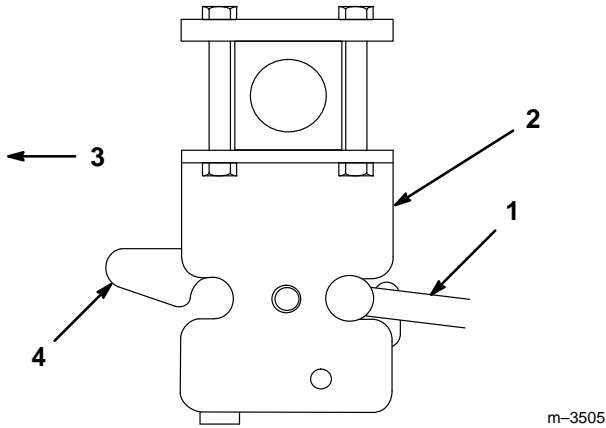

**Figure 9**

- |                               |                    |
|-------------------------------|--------------------|
| 1. Blade frame rear cross-bar | 3. Rear of tractor |
| 2. Rear Attach-A-Matic™       | 4. Latch           |

8. Now attach the blade frame to the mid section of the tractor by connecting the lift link to the blade frame and the lift attachment plate from beneath the tractor (Fig. 10 & 11).

A. Select the correct lift link for your application. The slotted link is the best choice for most applications, because it allows the blade to rise and fall over uneven or rough terrain (Fig. 10). Select the two-hole lift link for evenly dozing smooth, loose surfaces (Fig. 11).

The slotted link uses the (2) 3/8" x 3/4" (19 mm) clevis pins. Use the (2) 3/8" x 1" (25 mm) clevis pins with the two-hole (down pressure) link.

B. Connect the hole in the lift link to the upper front hole in the attachment lift plate with the proper (2) clevis pins (Fig. 10 & 11).

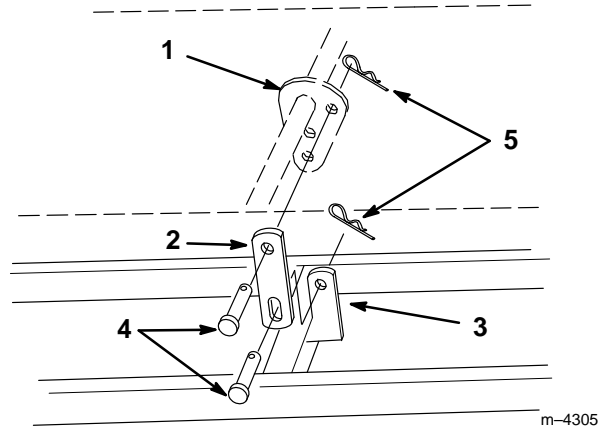
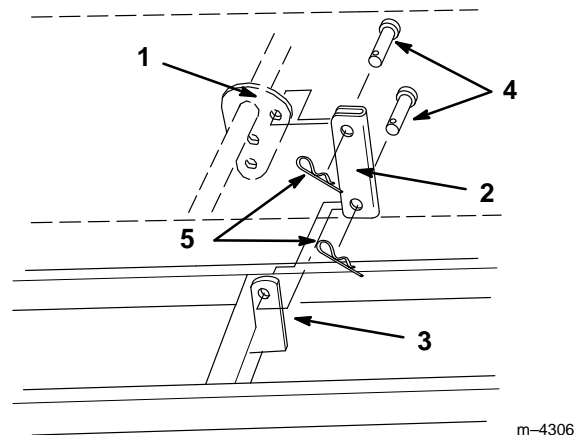

**Figure 10**

**Slotted Link Installation**

View from right side of tractor

- |                                 |                                    |
|---------------------------------|------------------------------------|
| 1. Attachment lift plate        | 4. Clevis pins 3/8" x 3/4" (19 mm) |
| 2. Slotted lift link            | 5. Hairpin cotter                  |
| 3. Blade frame connection plate |                                    |



**Figure 11**

**Two-hole Link Installation**

View from right side of tractor

- |                                 |                                  |
|---------------------------------|----------------------------------|
| 1. Attachment lift plate        | 4. Clevis pins 3/8" x 1" (25 mm) |
| 2. Two-hole lift link           | 5. Hairpin cotter                |
| 3. Blade frame connection plate |                                  |



**IMPORTANT:** Note the location of the fan and drive shaft on the tractor, because they will be rotating when the engine is started in the next step (Fig. 12).

**! DANGER**

**POTENTIAL HAZARD**

- Rotating shaft or cooling fan can cause injury.

**WHAT CAN HAPPEN**

- Fingers, hands, feet, hair, etc. can get caught by shaft.
- Loose clothing can get caught by shaft.

**HOW TO AVOID THE HAZARD**

- Keep hands and arms clear of rotating shaft or fan.

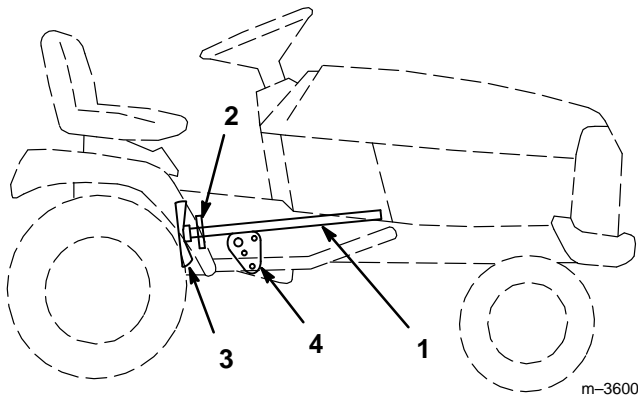

**Figure 12**

- |                         |                          |
|-------------------------|--------------------------|
| 1. Drive shaft          | 3. Fan                   |
| 2. Drive shaft coupling | 4. Attachment lift plate |

C. Ensure that the parking brake is set. Start the tractor and rise from the seat. Raise and lower the attachment lift until the hole in the lift link aligns with the hole in the blade frame connection plate. Then insert a clevis pin and hairpin cotter.

**! WARNING**

**POTENTIAL HAZARD**

- The “scissor” formed by moving parts of the tractor and the blade is dangerous.

**WHAT CAN HAPPEN**

- Hands and fingers can get caught between the blade parts and the tractor and be injured.

**HOW TO AVOID THE HAZARD**

- Keep hands away from moving parts while operating the attachment lift.

## Removing the Blade

**Note:** Save all hardware, rods, washers and hairpin cotters for re-use when installing the blade.

1. Park the machine on a level surface, set the parking brake, lower the attachment lift so the blade lightly touches the ground, and turn the ignition key to “OFF” to stop the engine. Remove the ignition key.

**! DANGER**

**POTENTIAL HAZARD**

- Rotating shaft or cooling fan can cause injury.

**WHAT CAN HAPPEN**

- Fingers, hands, feet, hair, etc. can get caught by shaft.
- Loose clothing can get caught by shaft.

**HOW TO AVOID THE HAZARD**

- Keep hands and arms clear of rotating shaft or fan.

2. Remove the (2) clevis pins and hairpin cotters securing the lift link between the blade and tractor attachment lift (Fig. 10 & 11).

3. Press the release button on the rear Attach-A-Matic™, release the latch levers and lower the frame.
4. Disconnect the cable from the release lever (Fig. 6).

**Note:** More slack in the cable may be obtained by moving the angle pin into the unlocked position.

5. Remove the control handle (Fig. 6) by rotating it to the 9:00 o'clock position, then pulling it out of its position in the frame.
6. Start the tractor and back it away from the blade control frame.

# Operation

## CAUTION

### POTENTIAL HAZARD

- Hitting fixed objects can cause the tractor to stop abruptly.

### WHAT CAN HAPPEN

- Stopping abruptly can cause loss of control, equipment damage and personal injury.

### HOW TO AVOID THE HAZARD

- Travel at a safe, slow speed.
- Check the area to be plowed and mark all fixed objects so they can be avoided.

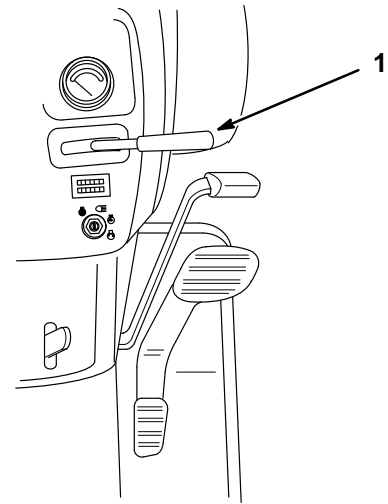

m-3258

Figure 13

1. Attachment lift lever

## Attachment Lift Lever

The attachment lift lever (Fig. 13 & 14) is used to raise and lower various attachments.

### Raising Attachments

1. Start the tractor.
2. Pull the attachment lift lever upward. In this position, the lift will hold the attachment in the up, or raised position.

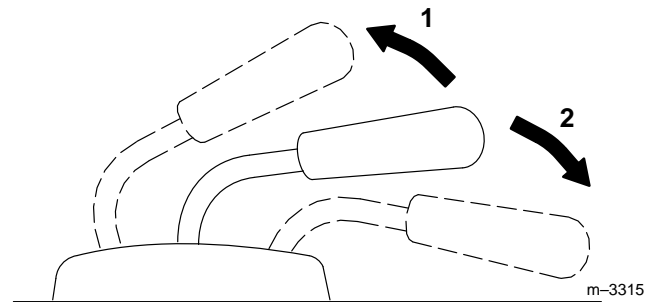

m-3315

Figure 14

1. Raise attachment
2. Lower attachment

## CAUTION

### POTENTIAL HAZARD

- When the engine is off, attachments in the raised position can gradually lower.

### WHAT CAN HAPPEN

- Someone nearby may be pinned or injured by the attachment as it lowers.

### HOW TO AVOID THE HAZARD

- Always lower the attachment lift each time you shut off the engine.

### Lowering Attachments

1. Start the tractor.
2. Push the attachment lift lever downward to lower the attachment.

## Adjusting the Blade Angle

The blade can be angled side to side, in five positions. The direction is controlled by the control handle (Fig. 15).

1. Raise the attachment.
2. Squeeze the release lever toward the handle (Fig. 15).
3. Push or pull the control handle to change blade-angle position and release the lever. The angle pin must snap into the hole in the channel to retain the blade position.

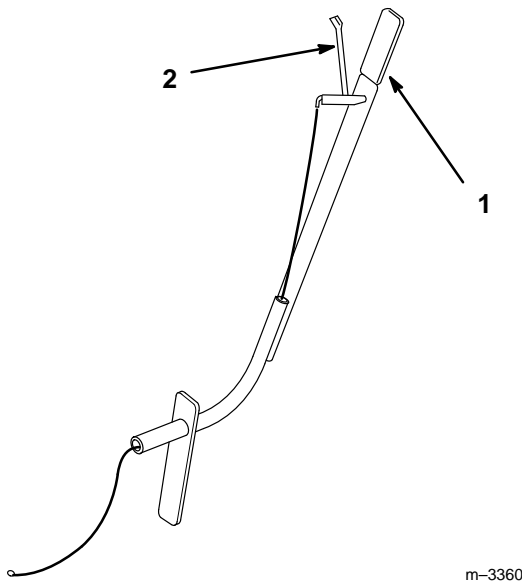

Figure 15

1. Control handle
2. Release lever

## Adjusting the Blade Trip Springs

The blade trip springs can be mounted in four positions. The top hole provides the greatest scraping pressure and the bottom hole provides the least scraping pressure (Fig. 16).

1. Remove the hairpin cotter and slide the rod from the blade and springs (Fig. 16).

2. Slide the rod through the springs and the new hole position in the blade (Fig. 16).

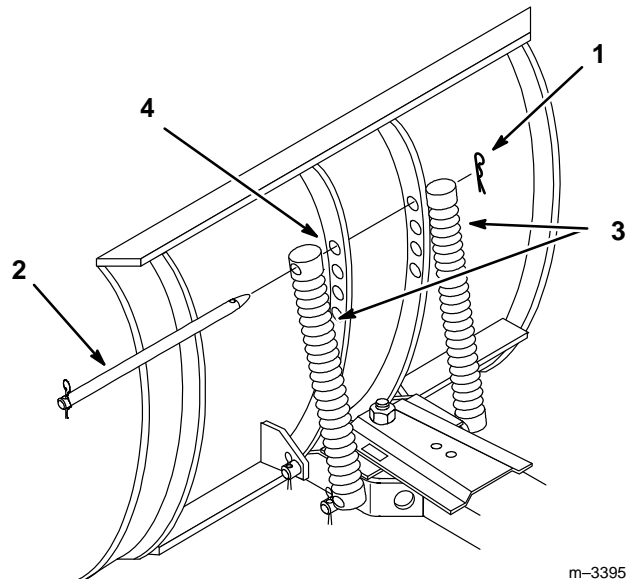

Figure 16

1. Hairpin cotter
2. Rod
3. Spring
4. Top hole

## Tips for Using the Blade

Remove snow as soon as possible after it falls. This produces best snow removal results.

Snow is generally removed from the driveway by making one pass down the center and then plowing snow to either side on successive passes.

If the tractor loses traction when using the snow blade, wheel weights and tire chains should be available from your dealer.

Blade trip springs can be adjusted for scraping aggressiveness and surface conditions. The second hole from the top is recommended for snow; refer to Adjusting the Blade Trip Springs, page 10.

# Maintenance

## Service Interval Chart

Service Operation	Each Use	5 Hours	25 Hours	Storage Service	Fall Service	Notes
Channel Pivot—grease			X	X	X	
Linkages—oil			X	X	X	
Chipped Surfaces—paint				X		
Scraper—check for wear				X	X	

** CAUTION**

**POTENTIAL HAZARD**

- If you leave the key in the ignition switch, someone could start the engine.

**WHAT CAN HAPPEN**

- Accidental starting of the engine could seriously injure you or other bystanders.

**HOW TO AVOID THE HAZARD**

- Remove the key from the ignition switch and pull the wire(s) off the spark plug(s) before you do any maintenance. Also push the wire(s) aside so it does not accidentally contact the spark plug(s).

## Greasing and Lubrication

### Service Interval Specification

Grease and oil the machine after every 25 operating hours or once a year, whichever occurs first.

**Grease Type:** General-purpose grease.

**Oil Type:** SAE 10W or 10W30.

### Grease the Channel Pivot

1. Lower the attachment.

2. Disengage the power take off (PTO), set the parking brake, and turn the ignition key to “OFF” to stop the engine. Remove the ignition key.
3. Clean the area around the channel pivot with a rag. Apply grease to the pivot bolt, frame and sector (Fig. 17).

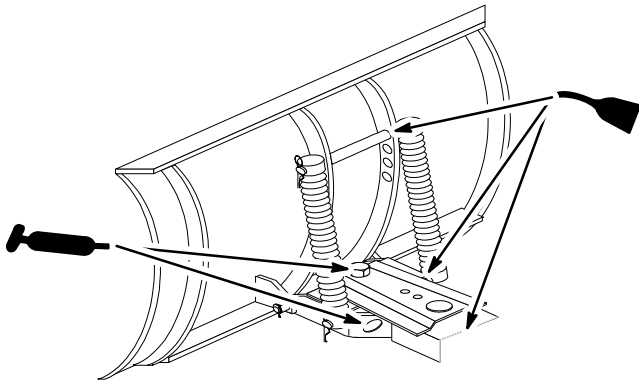

Figure 17

m-1473

4. Wipe off excess grease.

### Oil Linkages

1. Disengage the power take off (PTO), set the parking brake, and turn the ignition key to “OFF” to stop the engine. Remove the ignition key.
2. Place a few drops of oil on all movable linkages (Fig. 17).
3. Wipe off excess oil.

### Reversing the Scraper Blade

The scraper blade contacts the ground, preventing damage to the snow blade. Periodically inspect the scraper blade for wear. When the scraper becomes worn, before the working surface contacts the housing, reverse the scraper blade.

1. Start the tractor and raise the attachment lift lever (refer to Raising Attachments in your tractor owner’s manual) and support the housing off the ground.
2. Disengage the power take off (PTO), set the parking brake, and turn the ignition key to “OFF” to stop the engine. Remove the ignition key.

3. Remove the lock nuts and carriage bolts to remove the scraper blade (Fig. 18).
4. Reverse the scraper blade to replace a worn edge and install it with the previously removed hardware (Fig. 18).

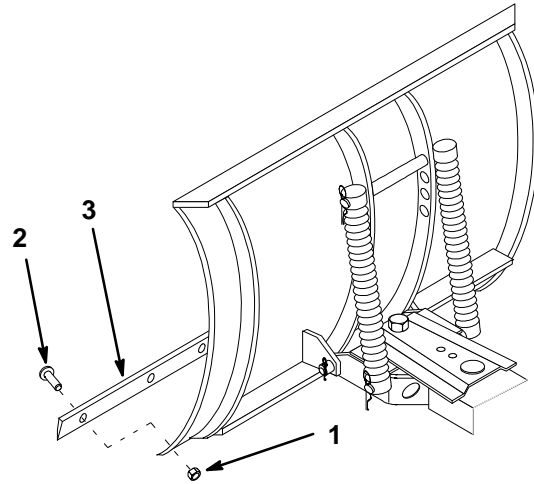

Figure 18

m-1468

1. Lock nut
2. Carriage bolt
3. Scraper blade

### Storage

1. Before long-term storage, wash the machine with mild detergent and water to remove dirt and grime from the entire machine.
2. Check the condition of the scraper blade; refer to Reversing the Scraper Blade, page 12.
3. Grease and oil the blade; refer to Greasing and Lubrication, page 11.
4. Check and tighten all bolts, nuts, and screws. Repair or replace any part that is damaged or defective.
5. Paint all scratched or bare metal surfaces. Paint is available from your Authorized Service Dealer.
6. Store the machine in a clean, dry garage or storage area. Cover the machine to protect it and keep it clean.



