



**Count on it.**

**Operator's Manual**

**Groundsmaster® 7200 Series  
Traction Unit**

Model No. 30495—Serial No. 316000001 and Up



This product complies with all relevant European directives; for details, please see the separate product-specific Declaration of Conformity (DOC) sheet.

**⚠ WARNING**

**CALIFORNIA  
Proposition 65 Warning**

**This product contains a chemical or chemicals known to the State of California to cause cancer, birth defects, or reproductive harm.**

**Diesel engine exhaust and some of its constituents are known to the State of California to cause cancer, birth defects, and other reproductive harm.**

It is a violation of California Public Resource Code Section 4442 or 4443 to use or operate the engine on any forest-covered, brush-covered, or grass-covered land unless the engine is equipped with a spark arrester, as defined in Section 4442, maintained in effective working order or the engine is constructed, equipped, and maintained for the prevention of fire.

This spark ignition system complies with Canadian ICES-002.

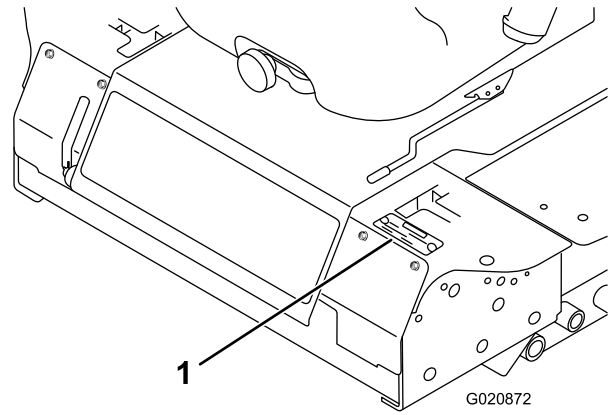
# Introduction

This machine is a ride-on, rotary-blade lawn mower intended to be used by professional, hired operators in commercial applications. It is primarily designed for cutting grass on well-maintained lawns in parks, sports fields, and on commercial grounds. It is not designed for cutting brush, mowing grass and other growth alongside highways, or for agricultural uses.

Read this information carefully to learn how to operate and maintain your product properly and to avoid injury and product damage. You are responsible for operating the product properly and safely.

You may contact Toro directly at [www.Toro.com](http://www.Toro.com) for product safety and operation training materials, accessory information, help finding a dealer, or to register your product.

Whenever you need service, genuine Toro parts, or additional information, contact an Authorized Service Dealer or Toro Customer Service and have the model and serial numbers of your product ready. [Figure 1](#) identifies the location of the model and serial numbers on the product. Write the numbers in the space provided.



**Figure 1**

1. Model and serial number location

<b>Model No.</b> _____
<b>Serial No.</b> _____

This manual identifies potential hazards and has safety messages identified by the safety-alert symbol ([Figure 2](#)), which signals a hazard that may cause serious injury or death if you do not follow the recommended precautions.



**Figure 2**

1. Safety-alert symbol

This manual also uses 2 words to highlight information. **Important** calls attention to special mechanical information and **Note** emphasizes general information worthy of special attention.

# Contents

Safety .....	4
General Safety.....	4
Sound and Vibration Level Information .....	4
Slope Table.....	4
Slope Indicator .....	5
Safety and Instructional Decals .....	6
Setup .....	12
1 Raising the ROPS .....	13
2 Installing the Mower Deck .....	13
3 Adjusting the Left, Front Caster Wheel.....	13
4 Checking the Tire Pressure .....	13
5 Installing Weights (for CE Compliance).....	14
6 Checking the Fluid Levels .....	15
7 Reading the Manuals and Viewing the Training Materials.....	15
Product Overview .....	15
Controls .....	15
Specifications .....	17
Attachments/Accessories.....	17
Before Operation .....	17
Before Operation Safety.....	17
Adding Fuel.....	18
Checking the Engine-Oil .....	19
Checking the Cooling System.....	19
Checking the Hydraulic System .....	19
Using the Rollover Protection System (ROPS) .....	19
Think Safety First.....	20
Using the Safety-Interlock System.....	21
Positioning the Seat .....	22
During Operation .....	23
During Operation Safety .....	23
Operating the Parking Brake .....	24
Starting and Stopping the Engine.....	25
Driving the Machine .....	25
Operating the Mower.....	26
Adjusting the Height of Cut .....	27
Operating Tips .....	27
After Operation .....	28
After Operation Safety .....	28
Pushing the Machine by Hand .....	28
Loading the Machine .....	29
Transporting the Machine.....	30
Maintenance .....	31
Recommended Maintenance Schedule(s) .....	31
Daily Maintenance Checklist.....	32
Pre-maintenance Procedures .....	33
Pre-Maintenance Safety.....	33
Unlatching the Seat.....	34
Lubrication .....	34
Greasing the Bearings and Bushings.....	34
Servicing the Mower-Deck Gear Box Lubricant.....	34
Engine Maintenance .....	35
Engine Safety.....	35
Checking the Air Cleaner.....	35
Servicing the Engine-Oil .....	36

Fuel System Maintenance .....	38
Servicing the Water Separator .....	38
Cleaning the Fuel Tank.....	38
Checking the Fuel Lines and Connections .....	39
Bleeding the Fuel System.....	39
Bleeding Air from the Injectors .....	39
Electrical System Maintenance .....	40
Electrical System Safety.....	40
Servicing the Battery.....	40
Storing the Battery.....	40
Checking the Fuses.....	40
Drive System Maintenance .....	41
Checking the Tire Pressure .....	41
Replacing the Caster Wheels and Bearings.....	42
Cooling System Maintenance .....	42
Cooling System Safety.....	42
Checking the Cooling System .....	42
Cleaning the Radiator.....	43
Brake Maintenance .....	43
Adjusting the Parking-Brake Interlock Switch .....	43
Belt Maintenance .....	44
Checking the Alternator-Belt Tension.....	44
Controls System Maintenance .....	45
Adjusting the Control-Lever Neutral-Interlock Switch.....	45
Adjusting the Control-Lever Neutral Return.....	45
Adjusting the Traction Drive for Neutral.....	46
Adjusting the Maximum Ground Speed .....	47
Adjusting the Tracking .....	48
Hydraulic System Maintenance .....	49
Hydraulic System Safety .....	49
Checking the Hydraulic System .....	49
Changing the Hydraulic Fluid And Filter.....	50
Cleaning .....	51
Cleaning Under the Mower.....	51
Disposing of Waste.....	51
Storage .....	51
Machine.....	51
Engine.....	52

# Safety

This machine has been designed in accordance with CEN standard ISO EN 5395:2013 and ANSI B71.4-2012 when the proper CE Kits have been installed per the Declaration of Conformity.

## General Safety

This product is capable of amputating hands and feet and of throwing objects. Always follow all safety instructions to avoid serious personal injury.

Using this product for purposes other than its intended use could prove dangerous to you and bystanders.

- Read and understand the contents of this *Operator's Manual* before you start the engine. Ensure that everyone using this product knows how to use it and understands the warnings.
- Do not put your hands or feet near moving components of the machine.
- Do not operate the machine without all guards and other safety protective devices in place and working on the machine.

- Keep clear of any discharge opening. Keep bystanders a safe distance from the machine.
- Keep children out of the operating area. Never allow children to operate the machine.
- Stop the machine and shut off the engine before servicing, fueling, or unclogging the machine.

Improperly using or maintaining this machine can result in injury. To reduce the potential for injury, comply with these safety instructions and always pay attention to the safety-alert symbol, which means Caution, Warning, or Danger—personal safety instruction. Failure to comply with these instructions may result in personal injury or death.

You can find additional items of safety information in their respective sections throughout this manual.

## Sound and Vibration Level Information

See the **CE Kit Manual (Model 30240)** for guaranteed sound powers, sound pressure levels, and vibration levels.

## Slope Table

This chart contains the maximum slope that you can safely operate the machine on.

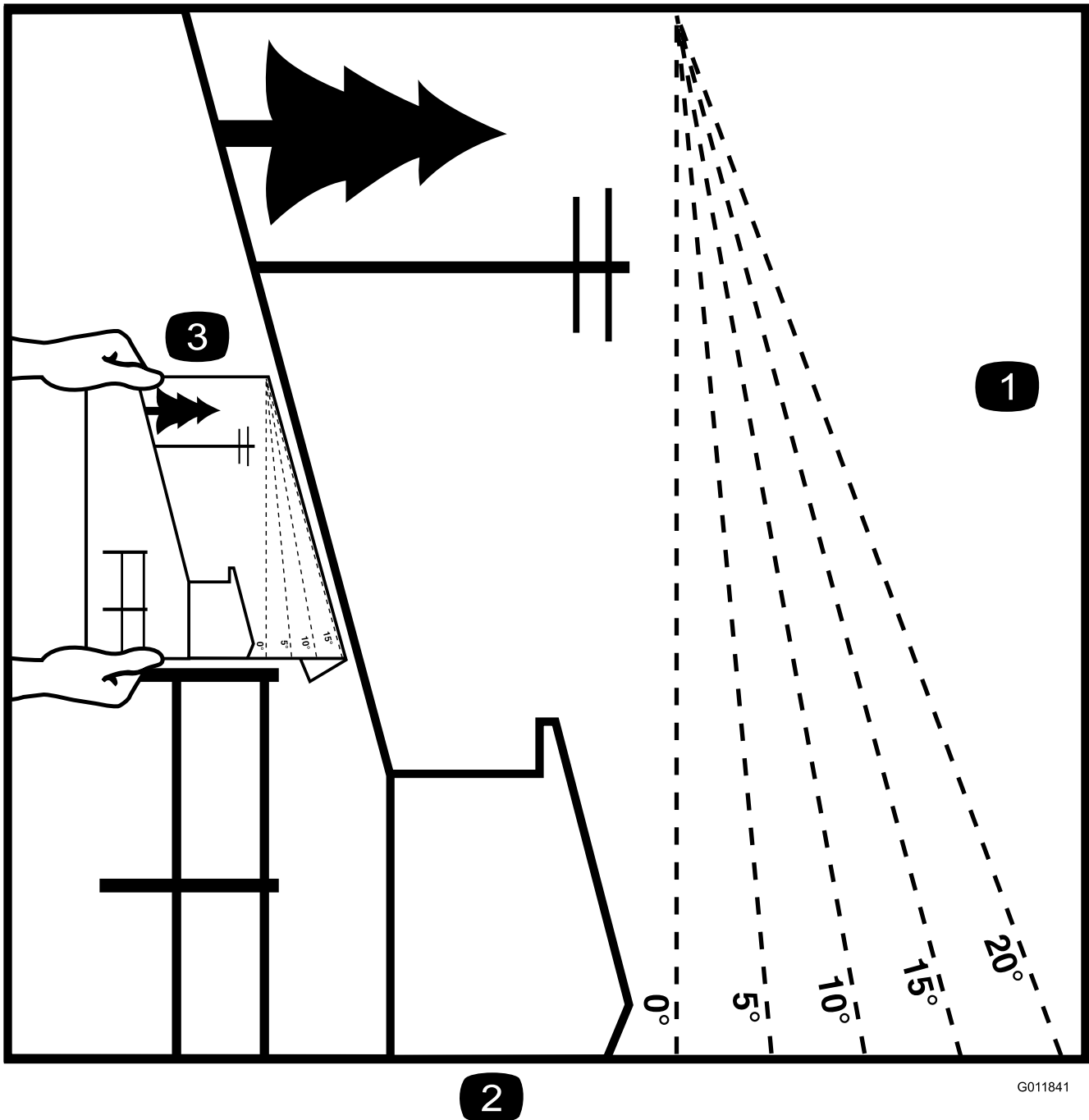
A	B	C
16 Degrees	17 Degrees	18 Degrees

### 2015+ Models

		30354	30353	30457	30456
		72 inch SDD	72 inch base	62 inch base	60 inch SDD
30495	GM7200	C	C	C	B

**Note:** Highlighted values shows the standard configuration of the model.

# Slope Indicator



G011841

**Figure 3**

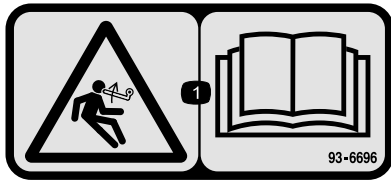
This page may be copied for personal use.

1. The maximum slope you can safely operate the machine on is noted in the table above. Use the slope chart to determine the degree of slope of hills before operating. **Do not operate this machine on a slope greater than what is rated for your machine.** Fold along the appropriate line to match the recommended slope.
2. Align this edge with a vertical surface, a tree, building, fence pole, etc.
3. Example of how to compare slope with folded edge.

# Safety and Instructional Decals



Safety decals and instructions are easily visible to the operator and are located near any area of potential danger. Replace any decal that is damaged or lost.



93-6696

1. Stored energy hazard—read the *Operator's Manual*.



106-6755

1. Engine coolant under pressure.
2. Explosion hazard—read the *Operator's Manual*.
3. Warning—do not touch the hot surface.
4. Warning—read the *Operator's Manual*.



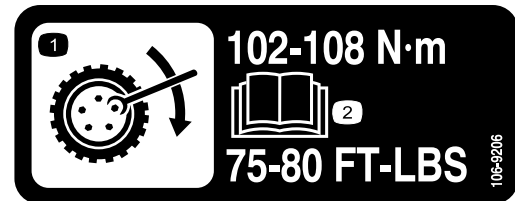
93-6697

1. Read the *Operator's Manual*.
2. Add SAE 80w-90 (API GL-5) oil every 50 hours.



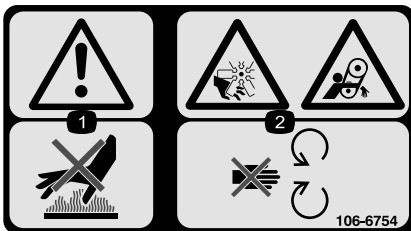
98-4387

1. Warning—wear hearing protection.



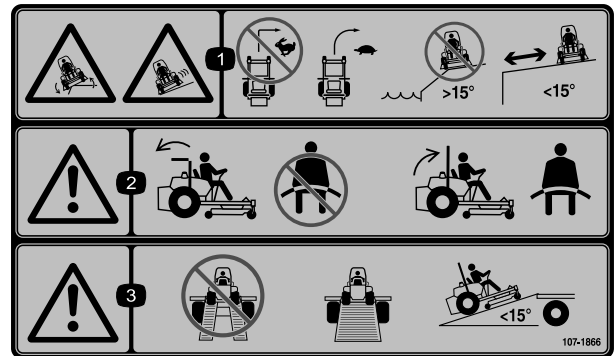
106-9206

1. Wheel torque specifications
2. Read the *Operator's Manual*.



106-6754

1. Warning—do not touch the hot surface.
2. Cutting/dismemberment hazard, fan and entanglement hazard, belt—stay away from moving parts.



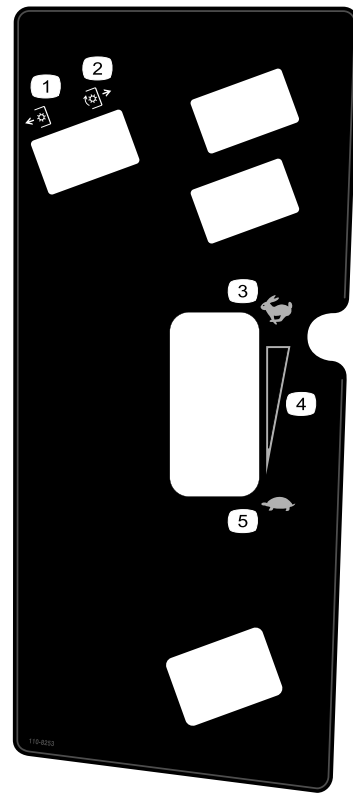
107-1866

1. Tipping hazard and sliding or loss of control hazard, drop-offs—do not turn sharply while traveling fast, instead, slow down and turn gradually; do not operate the machine near drop-offs, slopes greater than 15 degrees, or water; keep a safe distance from drop-offs.
2. Warning—if the roll bar is lowered, do not wear the seat belt; if the roll bar is raised, wear the seat belt.
3. Warning—do not use split ramps; use a full ramps when transporting machine; only use ramps with inclines less than 15 degrees.



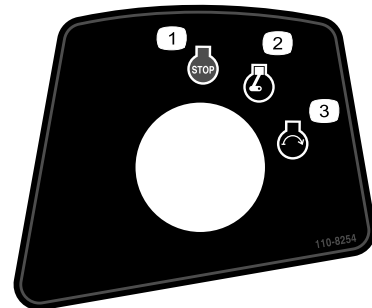
**107-3069**

1. Warning—there is no rollover protection when the roll bar is down.
2. To avoid injury or death from a rollover accident, keep the roll bar in the raised and locked position and wear the seat belt. Lower the roll bar only when absolutely necessary; do not wear the seat belt when the roll bar is down.
3. Read the *Operator's Manual*; drive slowly and carefully.



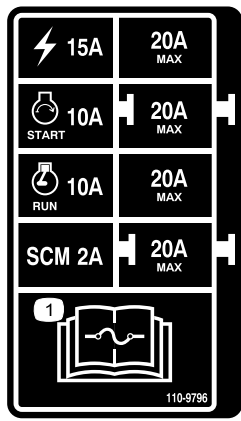
**110-8253**

- |            |                                |
|------------|--------------------------------|
| 1. PTO—Off | 4. Continuous-variable setting |
| 2. PTO—On  | 5. Slow                        |
| 3. Fast    |                                |



**110-8254**

- |                |                 |
|----------------|-----------------|
| 1. Engine—Stop | 3. Engine—Start |
| 2. Engine—Run  |                 |



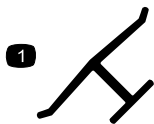
110-9796

1. Read the *Operator's Manual* for information on fuses.

**CALIFORNIA SPARK ARRESTER WARNING**

Operation of this equipment may create sparks that can start fires around dry vegetation. A spark arrester may be required. The operator should contact local fire agencies for laws or regulations relating to fire prevention requirements. 117-2718

117-2718



**Manufacturer's Mark**

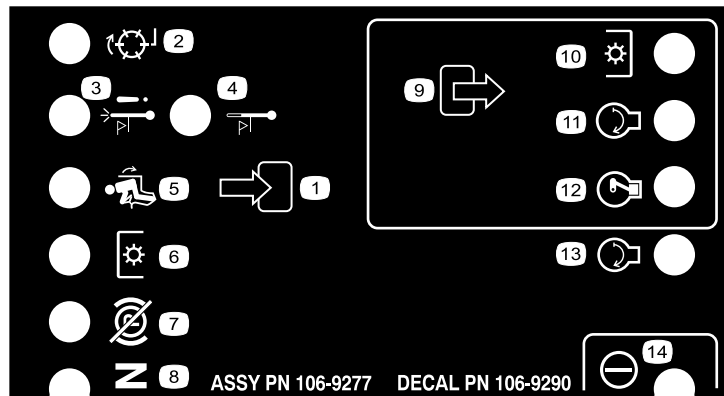
1. Indicates the blade is identified as a part from the original machine manufacturer.



**Battery Symbols**

Some or all of these symbols are on your battery

1. Explosion hazard
2. No fire, open flame, or smoking.
3. Caustic liquid/chemical burn hazard
4. Wear eye protection.
5. Read the *Operator's Manual*.
6. Keep bystanders a safe distance from the battery.
7. Wear eye protection; explosive gases can cause blindness and other injuries.
8. Battery acid can cause blindness or severe burns.
9. Flush eyes immediately with water and get medical help fast.
10. Contains lead; do not discard.



106-9290

- |                              |                        |                           |           |
|------------------------------|------------------------|---------------------------|-----------|
| 1. Inputs                    | 5. In seat             | 9. Outputs                | 13. Start |
| 2. Not active                | 6. Power takeoff (PTO) | 10. Power takeoff (PTO)   | 14. Power |
| 3. High temperature shutdown | 7. Parking brake off   | 11. Start                 |           |
| 4. High temperature warning  | 8. Neutral             | 12. Energize to run (ETR) |           |



# GROUNDMASTER 7200 / 7210 QUICK REFERENCE AID

## CHECK/SERVICE (daily)

1. OIL LEVEL, ENGINE
2. OIL LEVEL, HYDRAULIC TANK
3. COOLANT LEVEL, RADIATOR
4. FUEL /WATER SEPARATOR
5. PRECLEANER - AIR CLEANER

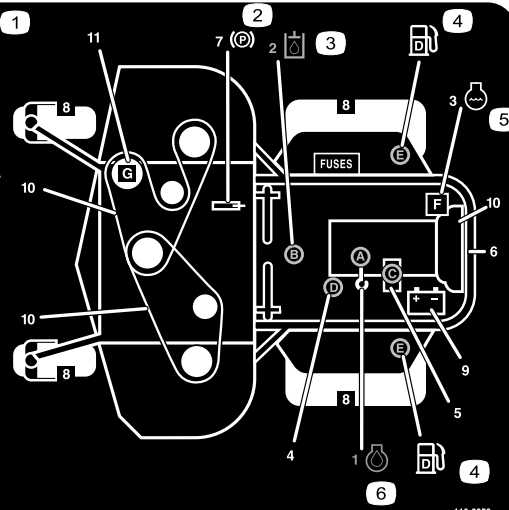
6. RADIATOR SCREEN
7. BRAKE FUNCTION
8. TIRE PRESSURE
9. BATTERY
10. BELTS - DECK, FAN, ALTERNATOR
11. GEARBOX

GREASING - SEE OPERATOR'S MANUAL

## FLUID SPECIFICATIONS/CHANGE INTERVALS

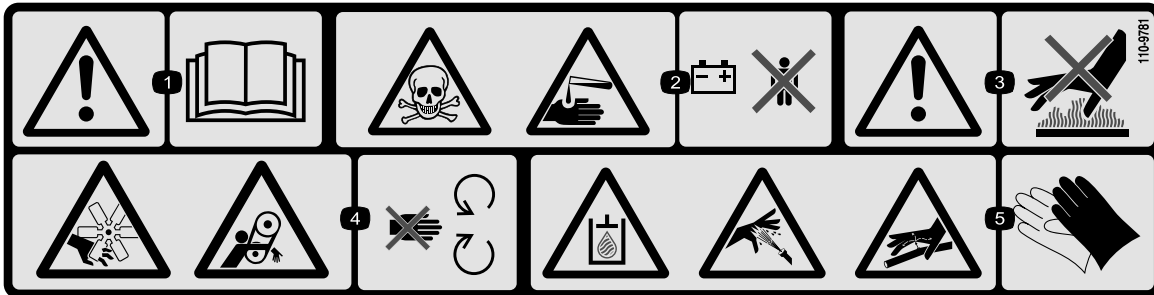
SEE OPERATOR'S MANUAL FOR INITIAL CHANGES.	FLUID TYPE	CAPACITY	CHANGE INTERVAL*		FILTER PART NO.
			FLUID	FILTER	
A. ENGINE OIL	*SAE 15W-40	3.9 QTS. WITH FILTER (3.7 LITERS)	150 HRS.	150 HRS.	108-3841
B. HYD. CIRCUIT OIL	MOBIL 424	10.9 QTS. (10.3 LITERS)	800 HRS.	800 HRS.	108-5194
C. AIR CLEANER			SEE INDICATOR		108-3810
D. WATER SEPARATOR			400 HRS.		110-9049
E. FUEL TANK	NO. 2-Diesel	11 GALS. (41 LITERS)	Drain and flush, 2 yrs.		
F. COOLANT	50/50 Ethylene glycol/water	6 QTS. (5.7 LITERS)	Drain and flush, 2 yrs.		
G. GEARBOX	SAE EP90W	12 oz. (355 mL)	400 HRS.		

\*SEE OPERATOR'S MANUAL FOR INITIAL CHANGES / WINTER USE.



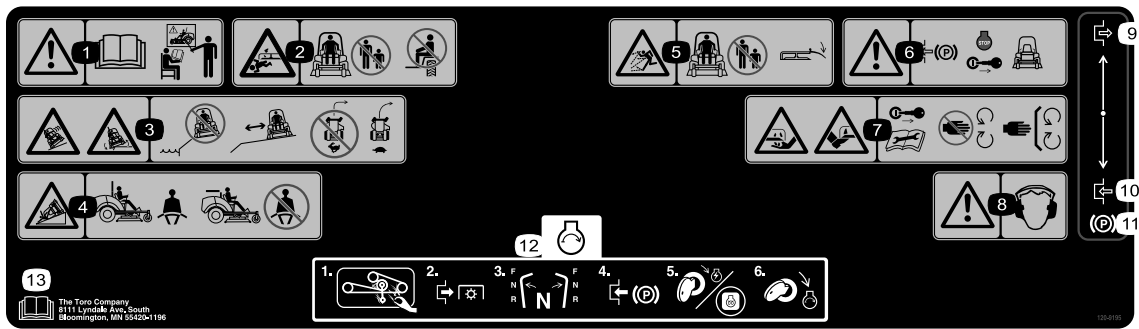
110-8252

1. Read the *Operator's Manual*.
2. Parking brake
3. Hydraulic oil
4. Fuel
5. Engine coolant
6. Engine oil



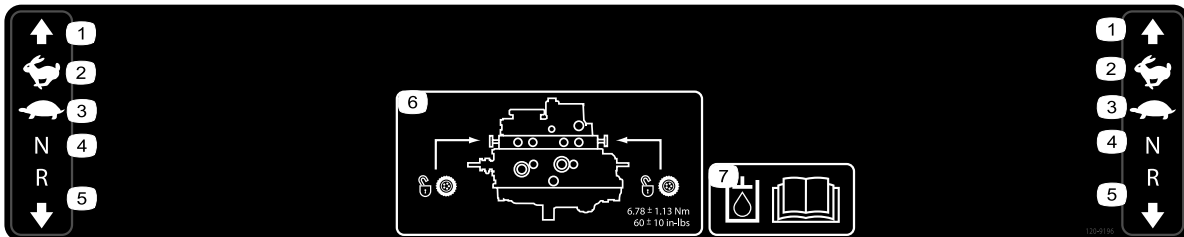
110-9781

1. Warning—read the *Operator's Manual*.
2. Poison and caustic liquid/chemical burn hazard—keep children a safe distance from the battery.
3. Warning—do not touch the hot surface.
4. Cutting/dismemberment hazard, fan and entanglement hazard, belt—stay away from moving parts.
5. Hydraulic fluid in system under pressure, escaping hydraulic fluid penetrating skin hazard, broken hydraulic lines hazard—wear protective hand protection when handling hydraulic system components.



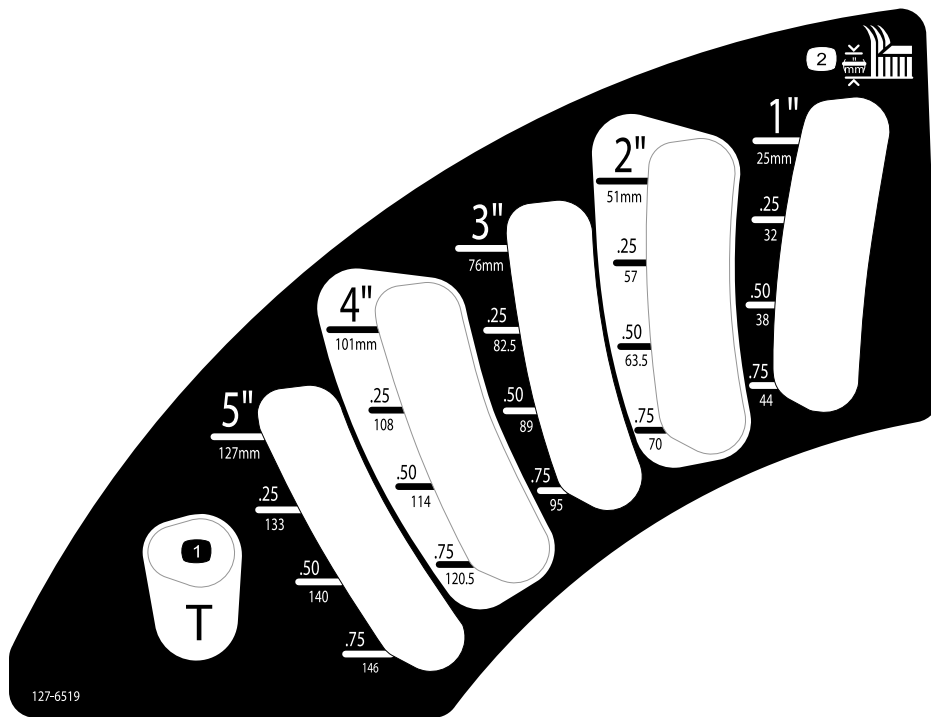
120-9195

1. Warning—read the *Operator's Manual* before operating and do not operate this machine unless you are trained.
2. Crushing/dismemberment hazard of bystanders—do not carry passengers, keep bystanders a safe distance from the machine.
3. Tipping, drop-off hazard—do not operate near water drop-offs, stay a safe distance from drop-offs, slow machine before turning, do not turn at high speeds.
4. Wear a seat belt when a ROPS is in place; do not wear a seat belt when ROPS is lowered.
5. Thrown object hazard—keep bystanders a safe distance from the machine; keep all deflectors and shields in place.
6. Warning—engage the parking brake, stop the engine and remove the ignition key before leaving the machine.
7. Cutting hazard of hand or foot—remove the ignition key and read the instructions before servicing or performing maintenance; keep away from moving parts.
8. Warning—wear hearing protection.
9. Engage
10. Disengage
11. Parking brake
12. To start the engine: clear any debris from the attachment, disengage the PTO, move the motion-control levers to the Neutral position, engage the parking brake, turn the ignition to Run, and wait for the glow plug light to turn off, turn the ignition key to Start.
13. Read the *Operator's Manual*.



120-9196

1. Forward
2. Fast
3. Slow
4. Neutral
5. Reverse
6. Tow valve location; torque the tow valves to 5.65 to 7.91 N·m (50 to 70 in-lb).
7. Read the *Operator's Manual* for more information on the hydraulic fluid.



1. Transport position

2. Height of cut

# Setup

## Loose Parts

Use the chart below to verify that all parts have been shipped.

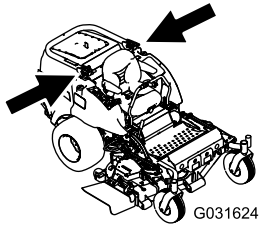
Procedure	Description	Qty.	Use
<b>1</b>	No parts required	–	Raise the ROPS.
<b>2</b>	Deck Installation Instructions	1	Install the mower deck.
<b>3</b>	No parts required	–	Adjust the left, front caster wheel.
<b>4</b>	No parts required	–	Check the tire pressure.
<b>5</b>	No parts required	–	Install weights.
<b>6</b>	No parts required	–	Check the hydraulic fluid, engine oil, and coolant levels.
<b>7</b>	Operator's Manual Engine owner's manual Parts Catalog Operator training material Engine warranty Declaration of Conformity Deck Installation Instructions	1 1 1 1 1 1 1	Read the manuals and view the training materials before operating the machine. Use the remaining parts for the installation of attachments.

# 1

## Raising the ROPS

No Parts Required

### Procedure



# 2

## Installing the Mower Deck

Parts needed for this procedure:

1	Deck <i>Installation Instructions</i>
---	---------------------------------------

### Procedure

Install the deck using the *Installation Instructions* for that deck.

# 3

## Adjusting the Left, Front Caster Wheel

No Parts Required

### Procedure

Adjust the left, front caster wheel to the outside position for 72-inch decks and to the inside position for 60-inch and 62-inch decks.

# 4

## Checking the Tire Pressure

No Parts Required

### Procedure

The tires are overinflated for shipping. Release some air to reduce the pressure. The correct air pressure is 103 kPa (15 psi) in the rear tires and 172 kPa (25 psi) in the caster wheels.

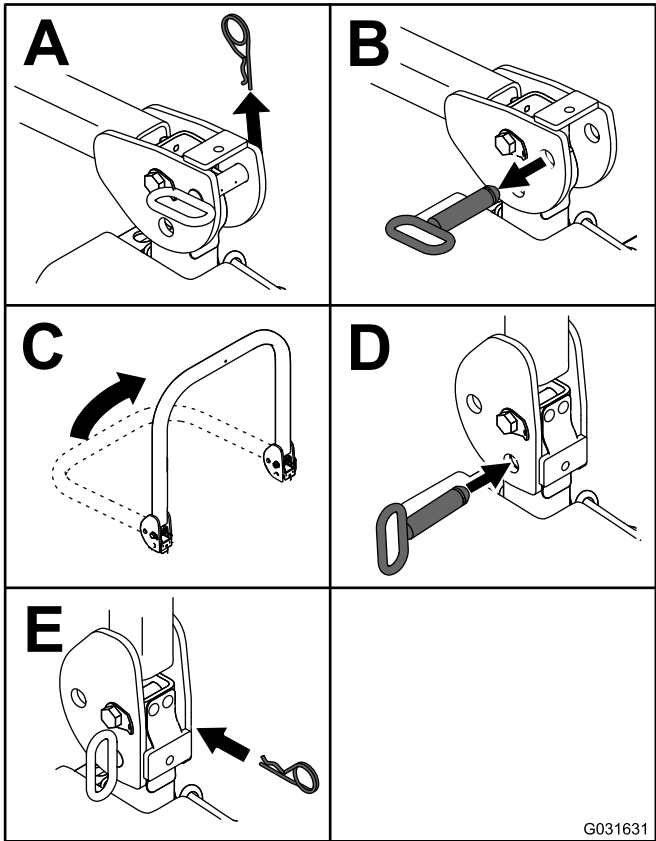


Figure 4

# 5

## Installing Weights (for CE Compliance)

### No Parts Required

### Procedure

Machines with 183 cm (72 inch) decks installed and no other attachments do not need added weight to meet CE standards. However, you may need to purchase and install additional weight depending on the mower deck size/type and the attachments that you install on the machine. The following table lists the various attachment configurations and the additional front weight needed for each model:

<b>Attachment Configuration</b>	<b>Weight Required with a 157.5 cm (62 inch) Base Deck (30457)</b>	<b>Weight Required with a 183 cm (72 inch) Base Deck (30353)</b>	<b>Weight Required with a 183 cm (72 inch) Side-discharge (30481)</b>
Groundsmaster 7200/7210 Traction Unit with no Added Attachments	10 kg (22 lb)	0 kg (0 lb)	0 kg (0 lb)
Groundsmaster 7200/7210 Traction Unit and Hard Canopy	34 kg (75 lb)	9.5 kg (21 lb)	15 kg (33 lb)
Groundsmaster 7200/7210 Traction Unit, Hard Canopy, and Road Light Kit	32.2 kg (71 lb)	28.5 kg (63 lb)	10 kg (22 lb)
Groundsmaster 7200/7210 Traction Unit, Hard Canopy, Road Light Kit, and Jack Stand	18 kg (40 lb)	17 kg (37 lb)	10 kg (22 lb)
Groundsmaster 7200/7210 Traction Unit, Hard Canopy, and Jack Stand	14 kg (31 lb)	10 kg (22 lb)	10 kg (22 lb)
Groundsmaster 7200/7210 Traction Unit, Road Light Kit, and Jack Stand	0 kg (0 lb)	0 kg (0 lb)	0 kg (0 lb)
Groundsmaster 7200/7210 Traction Unit and Road Light Kit	11.3 kg (25 lb)	0 kg (0 lb)	0 kg (0 lb)
Groundsmaster 7200/7210 Traction Unit and Jack Stand	0 kg (0 lb)	0 kg (0 lb)	0 kg (0 lb)

Contact your Authorized Toro Distributor to obtain the appropriate kits and weights for your machine.

# 6

## Checking the Fluid Levels

No Parts Required

### Procedure

1. Check the hydraulic fluid level before starting the engine, refer to [Hydraulic System Maintenance \(page 49\)](#).
2. Check the engine oil level before and after starting the engine, refer to [Checking the Engine-Oil Level \(page 36\)](#).
3. Check the cooling system before starting the engine; refer to [Checking the Cooling System \(page 42\)](#).

# 7

## Reading the Manuals and Viewing the Training Materials

Parts needed for this procedure:

1	<i>Operator's Manual</i>
1	Engine owner's manual
1	<i>Parts Catalog</i>
1	Operator training material
1	Engine warranty
1	<i>Declaration of Conformity</i>
1	<i>Deck Installation Instructions</i>

### Procedure

1. Read the manuals.
2. View the operator training materials.

## Product Overview

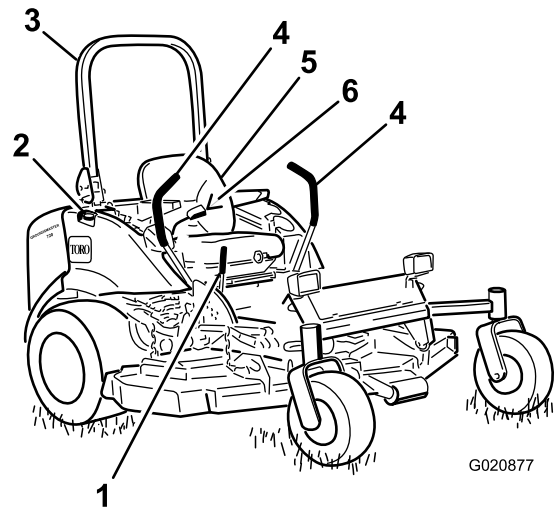


Figure 5

- |                          |                         |
|--------------------------|-------------------------|
| 1. Parking-brake lever   | 4. Motion-control lever |
| 2. Fuel cap (both sides) | 5. Seat                 |
| 3. Roll bar              | 6. Seat belt            |

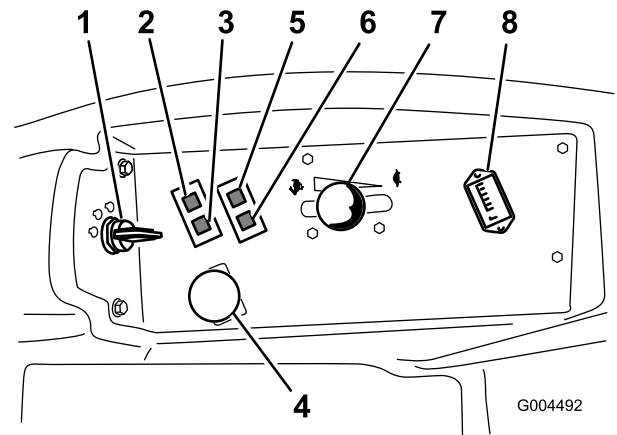


Figure 6

- |   |   |
|---|---|
| 1. Ignition switch                          | 5. Oil-pressure warning light           |
| 2. Engine-coolant-temperature warning light | 6. Charge-indicator light warning light |
| 3. Glow-plug light                          | 7. Throttle lever                       |
| 4. Power-takeoff (PTO) switch               | 8. Hour meter                           |

## Controls

Become familiar with all the controls before you start the engine and operate the machine ([Figure 5](#) and [Figure 6](#)).

### Motion-Control Levers

The motion-control levers control the forward and rearward motions as well as the turning of the machine. Refer to [Driving the Machine \(page 25\)](#).

## Parking-Brake Lever

Whenever you shut off the engine, engage the parking brake to prevent accidental movement of the machine. To engage the parking brake, pull the parking-brake lever rearward and up (Figure 7). To release the parking brake, push the parking-brake lever forward and down.

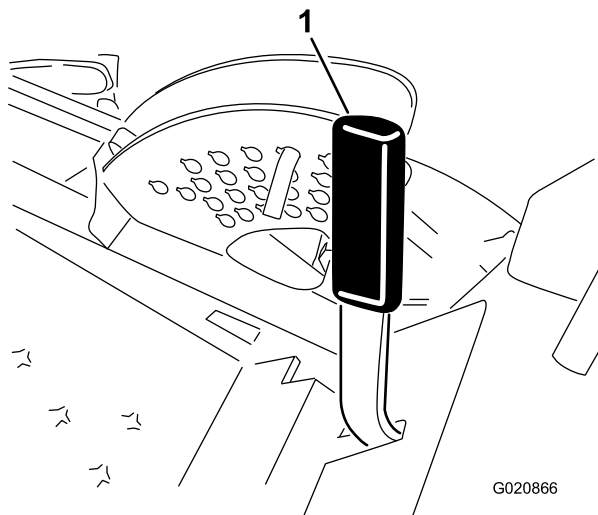


Figure 7

1. Parking-brake lever

## Ignition Switch

The ignition switch has 3 positions: OFF, ON/PREHEAT, and START.

## Throttle Lever

The throttle lever controls the speed of the engine, the speed of the blades, and, in conjunction with motion-control levers, the ground speed of the machine. Moving the throttle lever forward toward the FAST position increases the engine speed. Moving it rearward toward the SLOW position decreases the engine speed. Always run the machine with the throttle in the FAST position when cutting grass.

## Power-Takeoff (PTO) Switch

The power-takeoff (PTO) switch starts and stops the mower blades.

## Hour Meter

The hour meter records the number of hours that you operate the machine with the key switch in the RUN position. Use these times for scheduling regular maintenance.

## Glow-Plug Light (Orange Light)

The glow-plug indicator light illuminates when you turn the ignition switch to the ON position. It remains lit for 6 seconds. When the light turns off, the engine is ready to start.

## Engine-Coolant-Temperature Warning Light

This light illuminates and the cutting blades stop if the engine-coolant temperature is high. If you do not stop the machine and the coolant temperature rises another 11° C (20° F), the engine stops.

**Important:** If the mower deck shuts down and the temperature warning light is on, push the PTO knob down, drive to a safe, flat area, move the throttle lever to the SLOW position, move the motion-control levers into the NEUTRAL-LOCK position, and engage the parking brake. Idle the engine for several minutes while it cools to a safe level. Stop the engine and check the cooling system; refer to [Checking the Cooling System \(page 42\)](#).

## Charge-Indicator Light

The charge-indicator light illuminates when the system charging circuit malfunctions.

## Oil-Pressure-Warning Light

The oil-pressure warning light illuminates when the oil pressure in engine drops below a safe level. If the oil pressure is low, stop the engine and determine the cause. Repair the damage before starting the engine again.

## Fuel Gauge

The fuel gauge (Figure 8) indicates the quantity of fuel remaining in the fuel tanks.

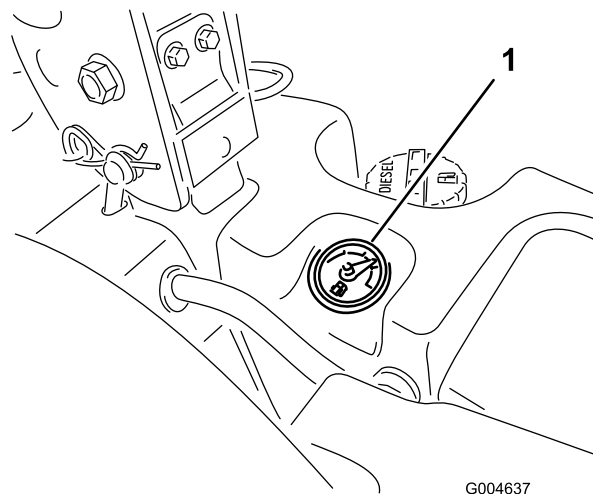


Figure 8

1. Fuel gauge



# Specifications

**Note:** Specifications and design are subject to change without notice.

Length	246 cm (97 inches)
Width (Rear Wheels)	145 cm (57 inches)
Height (Roll Bar Up)	184 cm (72 inches)
Height (Roll Bar Down)	122 cm (48 inches)
Weight, with 72 inch SDD (30354 or 30481)	934 kg (2,060 lb)
Weight, with 60 inch SDD (30456)	900 kg (1,985 lb)
Weight, with 72 inch Base Deck (30353)	876 kg (1,932 lb)
Weight, with 62 inch Base Deck (30457)	855 kg (1,884 lb)

## Attachments/Accessories

A selection of Toro approved attachments and accessories is available for use with the machine to enhance and expand its capabilities. Contact your Authorized Service Dealer or Distributor or go to [www.Toro.com](http://www.Toro.com) for a list of all approved attachments and accessories.

# Operation

**Note:** Determine the left and right sides of the machine from the normal operating position.

## Before Operation

### Before Operation Safety

#### General Safety

- Never allow children or untrained people to operate or service the machine. Local regulations may restrict the age of the operator. The owner is responsible for training all operators and mechanics.
- Become familiar with the safe operation of the equipment, operator controls, and safety signs. Know how to stop the machine and engine quickly.
- Check that all safety devices are attached and functioning properly. This includes, but is not limited to, operator-presence controls; safety switches and shields; the rollover protection system (ROPS); attachments; and brakes. Do not operate the machine unless all safety devices are in position and functioning as intended by the manufacturer.
- Always inspect the machine to ensure that the blades, blade bolts, and cutting assembly are not worn or damaged. Replace worn or damaged blades and bolts in sets to preserve balance.
- Inspect the area where you will use the machine and remove all objects that the machine could potentially throw.
- Evaluate the terrain to determine the appropriate equipment and any attachments or accessories required to operate the machine properly and safely.

## Fuel Safety

### **▲ DANGER**

In certain conditions, fuel is extremely flammable and highly explosive. A fire or explosion from fuel can burn you and others and can damage property.

- Fill the fuel tank outdoors, in an open area, when the engine is cold. Wipe up any fuel that spills.
- Never fill the fuel tank inside an enclosed trailer.
- Never smoke when handling fuel, and stay away from an open flame or where fuel fumes may be ignited by a spark.
- Store fuel in an approved container and keep it out of the reach of children. Never buy more than a 180-day supply of fuel.
- Do not operate the machine without the entire exhaust system in place and in proper working condition.

### **▲ WARNING**

Fuel is harmful or fatal if swallowed. Long-term exposure to vapors can cause serious injury and illness.

- Avoid prolonged breathing of vapors.
- Keep your hands and face away from the nozzle and the fuel-tank opening.
- Keep fuel away from your eyes and skin.
- Use only an approved fuel container.
- Never remove the fuel cap or add fuel to the fuel tank while the engine is running.
- Never fill containers inside a vehicle or on a truck or trailer bed with a plastic liner. Always place containers on the ground and away from your vehicle before filling.
- Remove the equipment from the truck or trailer and add fuel to it while it is on the ground. If this is not possible, then add fuel using a portable container rather than from a fuel-dispenser nozzle.
- Keep the fuel-dispenser nozzle in contact with the rim of the fuel tank or container opening at all times until fueling is complete. Do not use a nozzle lock-open device.
- If you spill fuel on your clothing, change your clothing immediately.
- Fill the fuel tank until the fuel level is 25 mm (1 inch) below the bottom of the filler neck. Do not overfill the fuel tank. Replace the fuel-tank cap and tighten it securely.

## Adding Fuel

### Recommended Fuel

Use only clean, fresh diesel fuel with ultra low (<15 ppm) sulfur content meeting ASTM D 975 or EN 590 specifications. The minimum cetane rating should be 40. Purchase fuel in quantities that can be used within 180 days to ensure fuel freshness.

**Important:** Use of non-ultra low sulfur fuel causes damage to the engine emission system.

**Fuel tank capacity:** 43.5 L (11.5 US gallons)

Use summer-grade diesel fuel (No. 2-D) at temperatures above -7°C (20°F) and winter grade (No. 1-D or No. 1-D/2-D blend) below that temperature. Use of winter-grade fuel at lower temperatures provides lower flash point and cold-flow characteristics, which eases starting and reduces fuel filter plugging.

Use of summer-grade fuel above -7°C (20°F) contributes toward longer fuel-pump life and increased power compared to winter-grade fuel.

**Important:** Do not use kerosene or gasoline instead of diesel fuel. Failure to observe this caution damages the engine.

### Biodiesel Ready

This machine can also use a biodiesel blended fuel of up to B20 (20% biodiesel, 80% petrodiesel). The petrodiesel portion must be ultra low sulfur. Observe the following precautions:

- The biodiesel portion of the fuel must meet specification ASTM D6751 or EN14214.
- The blended fuel composition should meet ASTM D975 or EN590.
- Painted surfaces may be damaged by biodiesel blends.
- Monitor seals, hoses, gaskets in contact with fuel as they may be degraded over time.
- Fuel filter plugging may be expected for a time after converting to biodiesel blended fuel.
- Contact your distributor if you wish more information on biodiesel.

## Filling the Fuel Tank

**Important:** The fuel tanks are connected, but the fuel does not transfer quickly from one tank to the other. It is important when filling that you park on a level surface. If you park on a hill, you may inadvertently overfill the tanks.

**Important:** Do not overfill the fuel tanks.

**Important:** Do not open the fuel tanks when parked on a hill. The fuel could spill out.

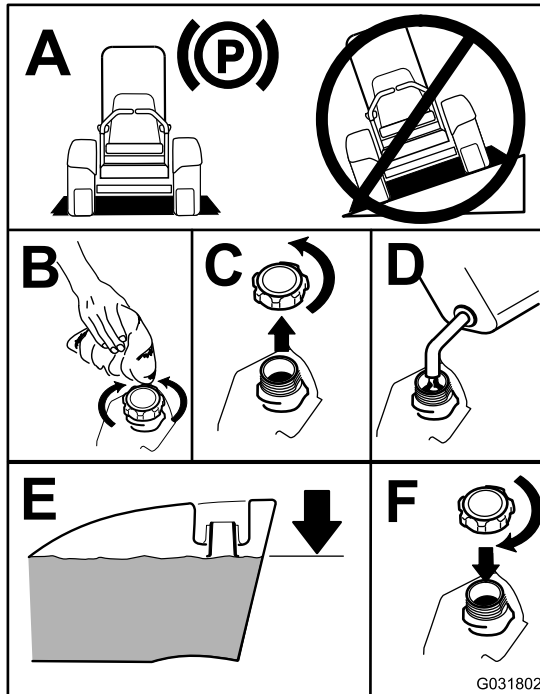


Figure 9

**Note:** If possible, fill the fuel tanks after each use. This minimizes buildup of condensation inside the fuel tank.

## Checking the Engine-Oil

Before you start the engine and use the machine, check the oil level in the engine crankcase; refer to [Checking the Engine-Oil Level \(page 36\)](#).

## Checking the Cooling System

Before you start the engine and use the machine, check the cooling system; refer to [Checking the Cooling System \(page 42\)](#).

## Checking the Hydraulic System

Before you start the engine and use the machine, check the hydraulic system; refer to [Checking the Hydraulic System \(page 49\)](#).

## Using the Rollover Protection System (ROPS)

### ⚠ WARNING

To avoid injury or death from rollover: keep the roll bar in the raised locked position and use the seat belt.

Ensure that the rear part of the seat is secured with the seat latch.

### ⚠ WARNING

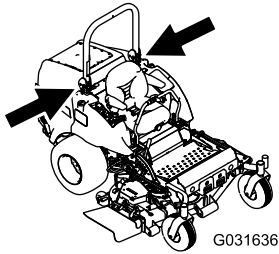
There is no rollover protection when the roll bar is in the down position.

- Lower the roll bar only when absolutely necessary.
- Do not wear the seat belt when the roll bar is in the down position.
- Drive slowly and carefully.
- Raise the roll bar as soon as clearance permits.
- Check carefully for overhead clearances (i.e. branches, doorways, electrical wires) before driving under any objects and do not contact them.

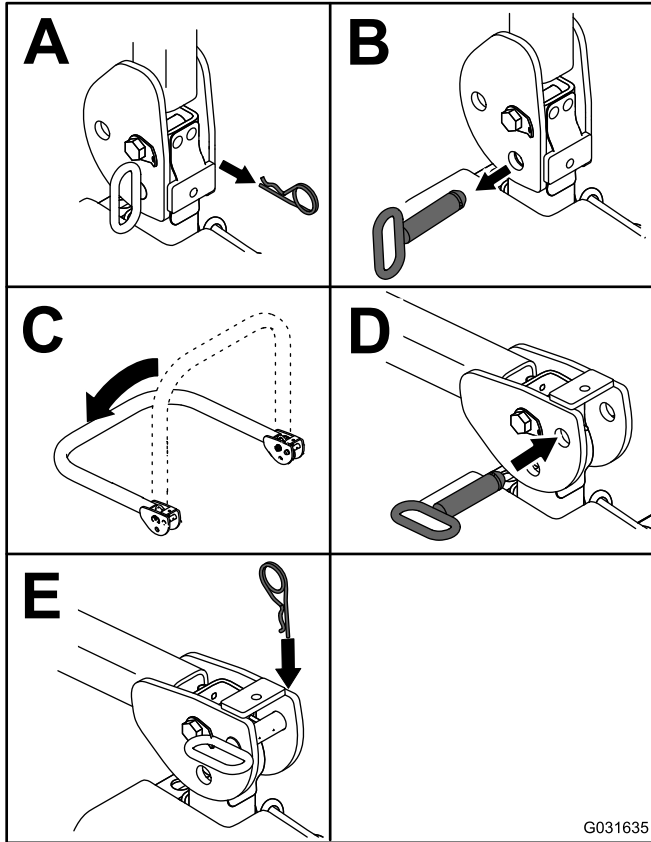
## Lowering the ROPS

Lower the ROPS as shown in [Figure 11](#).

**Note:** Push the bar forward to relieve pressure on the pins.



G031636



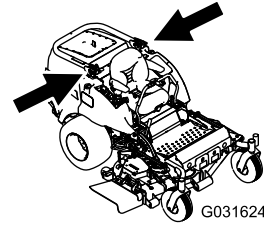
G031635

Figure 10

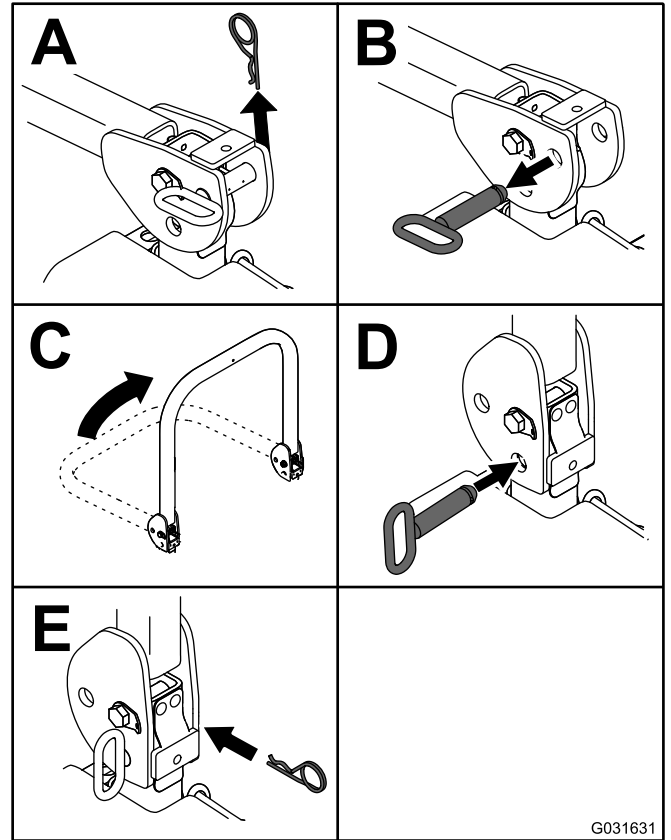
**Note:** Secure the ROPS so that it does not damage the hood.

## Raising the ROPS

Raise the ROPS as shown in [Figure 10](#).



G031624



G031631

Figure 11

**Important:** Always use the seat belt when the roll bar is in the raised and locked position. Do not use the seat belt when the roll bar is in the lowered position.

## Think Safety First

Please read all safety instructions and symbols in the safety section. Knowing this information could help you or bystanders avoid injury.

### **⚠ DANGER**

Operating the machine on wet grass or steep slopes can cause sliding and loss of control.

- Reduce speed and use extreme caution on slopes.
- Do not operate the machine near water.

## ⚠ DANGER

Wheels dropping over edges can cause rollovers, which may result in serious injury, death, or drowning.

Do not operate the machine near drop-offs.

## ⚠ DANGER

Operating the machine while the roll bar is down may lead to serious injury or death in the event of a rollover.

Always keep the roll bar in the fully raised and locked position and use the seat belt.

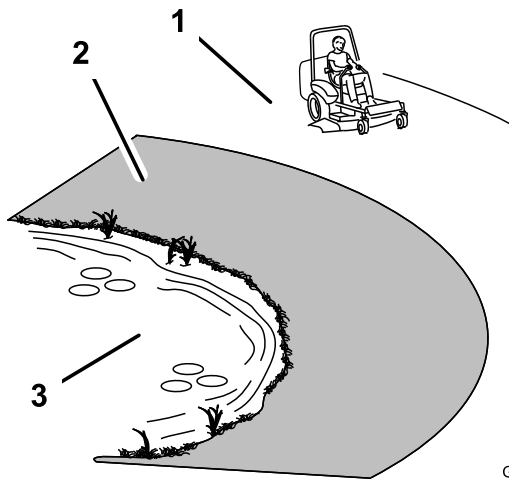


Figure 12

G032833

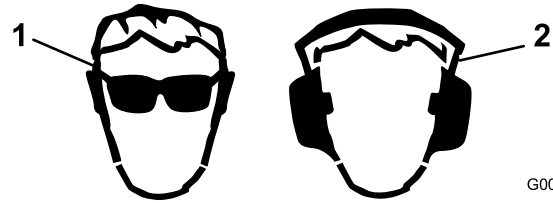
1. Safe zone
2. Use a walk-behind mower and/or hand trimmer near drop-offs and water.
3. Water

## ⚠ CAUTION

This machine produces sound levels in excess of 85 dBA at the operator's ear and can cause hearing loss through extended periods of exposure.

Wear hearing protection when operating this machine.

Use protective equipment for your eyes, ears, hands, feet, and head.



G009027

Figure 13

1. Wear eye protection.
2. Wear hearing protection.

## Using the Safety-Interlock System

### ⚠ CAUTION

If the safety-interlock switches are disconnected or damaged, the machine could operate unexpectedly, causing personal injury.

- Do not tamper with the interlock switches.
- Check the operation of the interlock switches daily and replace any damaged switches before operating the machine.

## Understanding the Safety-Interlock System

The safety-interlock system prevents the engine from starting unless:

- You are sitting on the seat or the parking brake is engaged.
- The power takeoff (PTO) is disengaged.
- The motion-control levers are in the NEUTRAL-LOCK position.
- The engine temperature is below the maximum operating temperature.

The safety-interlock system also stops the engine when you move the traction controls from the NEUTRAL-LOCK position with the parking brake engaged. If you rise from the seat when the PTO is engaged, there is a 1-second delay and then the engine stops.

## Testing the Safety-Interlock System

**Service Interval:** Before each use or daily

Test the safety-interlock system before you use the machine each time. If the safety system does not operate as described below, have an Authorized Service Dealer repair the safety system immediately.

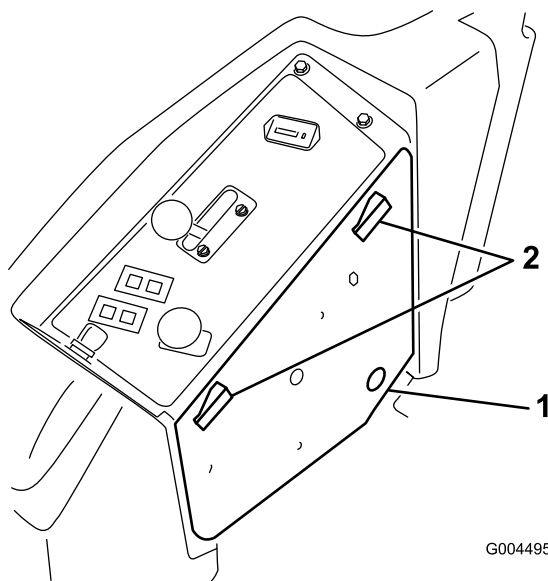
1. Sit on the seat, engage the parking brake, and move the PTO to the ON position. Try starting the engine; the engine should not crank.
2. Sit on the seat, engage the parking brake, and move the PTO to the OFF position. Move either motion-control lever out of the NEUTRAL-LOCK position. Try starting

the engine; the engine should not crank. Repeat for other motion-control lever.

3. Sit on the seat, engage the parking brake, move the PTO switch to the OFF position, and move the motion-control levers to the NEUTRAL-LOCK position. Start the engine. While the engine is running, release the parking brake, engage the PTO, and rise slightly from the seat; the engine should stop within 2 seconds.
4. Without an operator on the seat, engage the parking brake, move the PTO switch to the OFF position, and move the motion-control levers to the NEUTRAL-LOCK position. Start the engine. While the engine is running, center either motion control; the engine should stop within 2 seconds. Repeat for the other motion-control lever.
5. Without an operator on the seat, disengage the parking brake, move the PTO switch to the OFF position, and move the motion-control levers to the NEUTRAL-LOCK position. Try starting the engine; the engine should not crank.

## Using the SCM to Diagnose System Problems

The machine is equipped with a standard control module (SCM) monitoring system that tracks the function of various key systems. The SCM is located under the right control panel. Access it through the side panel cover (Figure 14). To open the side panel cover, release the 2 latches and pull out on it.

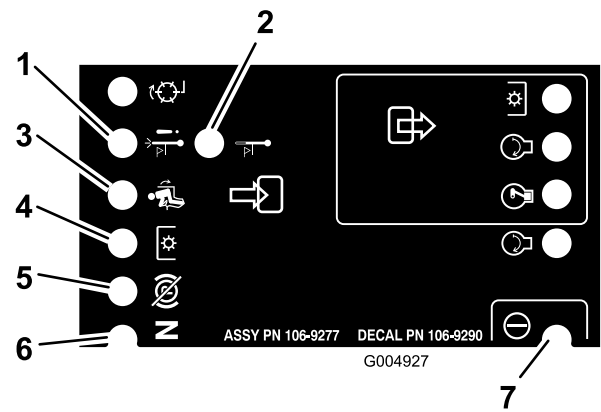


**Figure 14**

1. Side panel cover
2. Latches

On the face of the SCM are 11 LEDs that illuminate to indicate various system conditions. You can use 7 of these lights for system diagnosis. Refer to Figure 15 for a description of what each light means. For details on using the

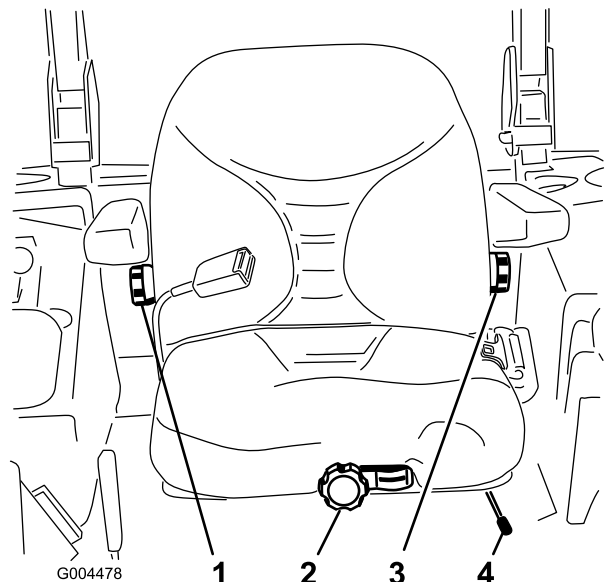
rest of the SCM functions, refer to the *Service Manual*, available through your Authorized Toro Distributor.



**Figure 15**

1. High temperature shutdown—the engine temperature has exceeded safe levels and the engine has been shut down. Check the cooling system.
2. High temperature warning—the engine temperature is approaching unsafe levels and the mower deck has been shut down. Check the cooling system.
3. Operator is in the seat.
4. The PTO is on.
5. The parking brake is not engaged.
6. Controls are in neutral.
7. The SCM is receiving power and is operational.

## Positioning the Seat



**Figure 16**

1. Back-rest knob
2. Seat-suspension knob
3. Lumbar-support-adjustment knob
4. Seat-position-adjustment lever

## Changing the Seat Position

You can move the seat forward and backward. Position the seat where you have the best control of the machine and are most comfortable.

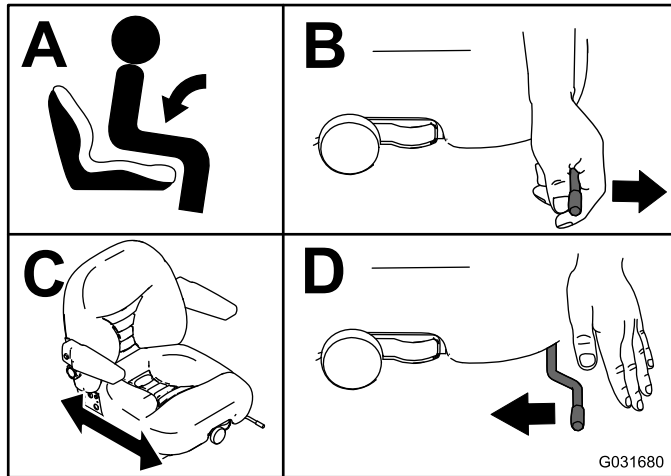


Figure 17

## Changing the Seat Suspension

You can adjust the seat for a smooth and comfortable ride. Position the seat where you are most comfortable.

Without sitting on the seat, turn the knob in front either direction (Figure 16).

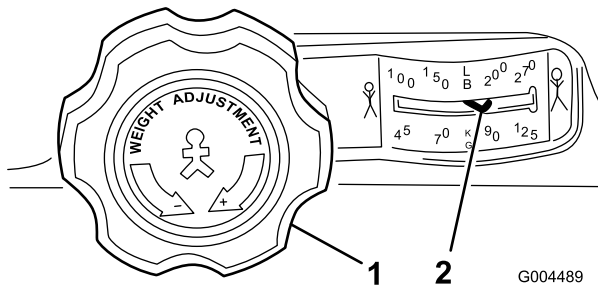


Figure 18

1. Seat-suspension knob
2. Operator-weight setting

## Changing the Back Position

You can adjust the back of the seat for a comfortable ride. Position the back of the seat where you are most comfortable.

To adjust it, turn the knob, under the right arm rest, in either direction (Figure 16).

## Changing the Lumbar Support

You can adjust the lumbar support for your lower back.

To adjust it, turn the knob, under the left arm rest, in either direction (Figure 16).

# During Operation

## During Operation Safety

### General Safety

- The owner/user can prevent and is responsible for accidents that may cause injuries to himself/herself and others and for damage to property.
- Wear appropriate clothing, including eye protection; slip-resistant, substantial footwear; and hearing protection. Wearing safety shoes and long pants is advisable and required by some local ordinances and insurance regulations. Tie back long hair, secure loose clothing, and do not wear jewelry.
- Ensure that all drives are in the NEUTRAL position, the parking brake is engaged, and you are in the operating position before you start the engine.
- Keep all body parts, including hands and feet, away from all moving parts.
- Do not operate the machine while ill, tired, or under the influence of alcohol or drugs.
- Keep the direction of the mower discharge away from people and pets.
- Do not mow in reverse unless it is absolutely necessary. If you must mow in reverse, look behind and down for small children before and while moving the machine in reverse. Stay alert and stop the machine if a child enters the area.
- Use extreme care when approaching blind corners, shrubs, trees, or other objects that may block your view.
- Do not mow near drop-offs, ditches, or embankments. The machine could suddenly roll over if a wheel goes over the edge or if the edge caves in.
- Never carry passengers on the machine.
- Operate the machine only in good visibility and appropriate weather conditions. Do not operate the machine when there is the risk of lightning.
- Do not mow on wet grass. Reduced traction could cause the machine to slide.
- Never raise the mower deck with the blades running.
- Stop the machine and inspect the blades after striking an object or if there is an abnormal vibration in the machine. Make all necessary repairs before resuming operation.
- Stop the blades whenever you are not mowing, especially while crossing loose terrain such as gravel.
- Slow down and use caution when making turns and crossing roads and sidewalks with the machine. Always yield the right-of-way.
- Turn on the flashing warning lights on the machine whenever you travel on a public road, except where such use is prohibited by law.
- Disengage the drive to the attachment and shut off the engine before adding fuel and adjusting the height of cut.

- Reduce the throttle setting before stopping the engine and, if the engine has a fuel-shutoff valve, shut off the fuel when you have finished operating the machine.
- Never run an engine in an area where exhaust gases are enclosed.
- Never leave a running engine unattended.
- Before leaving the operating position, do the following:
  - Stop the machine on level ground.
  - Disengage the power take-off and lower the attachments.
  - Set the parking brake.
  - Shut off the engine and remove the key.
  - Wait for all moving parts to stop.
- Do not change the governor settings on or overspeed the engine. Operating the engine at excessive speed may increase the potential for personal injury.
- Do not use the machine as a towing vehicle.
- Use accessories and attachments approved by The Toro® Company only.

## Rollover Protection System (ROPS) Safety

- **Do not** remove the ROPS from the machine.
- Ensure that the seat belt is attached and that you can release it quickly in the event of an emergency.
- Always wear your seat belt when the ROPS is up.
- Check carefully for overhead clearances, such as branches, doorways, and electrical wires, before driving the machine under them. Do not contact them.
- Keep the ROPS in safe operating condition by thoroughly inspecting it periodically for damage and keeping all the mounting fasteners tight.
- Replace a damaged ROPS. Do not repair or revise it.
- Any alterations to a ROPS must be approved by The Toro® Company.

## Slope Safety

- Slow down the machine and use extra care on hillsides. Travel in the recommended direction on hillsides. Turf conditions can affect the stability of the machine.
- Avoid starting, stopping, or turning the machine on a slope. If the tires lose traction, disengage the blade(s) and proceed slowly straight down the slope.
- Do not turn the machine sharply. Use care when reversing the machine.
- When operating the machine on a slope, always keep all cutting units lowered.

- Avoid turning the machine on slopes. If you must turn, turn slowly and gradually downhill, if possible.
- Use extra care while operating the machine with attachments; they can affect the stability of the machine.

## Operating the Parking Brake

Always set the parking brake when you stop the machine or leave it unattended.

### Setting the Parking Brake

#### **⚠ WARNING**

The parking brake may not hold the machine parked on a slope and could cause personal injury or property damage.

Do not park the machine on slopes unless the wheels are chocked or blocked.

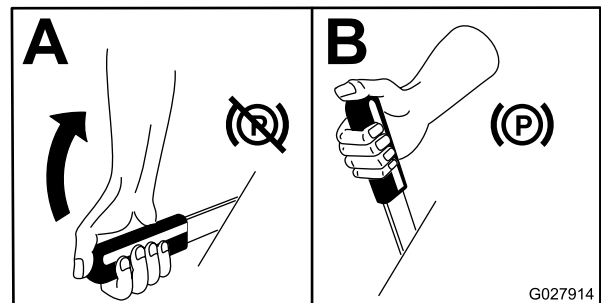


Figure 19

### Releasing the Parking Brake

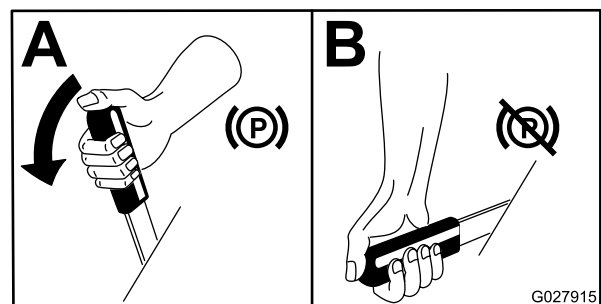


Figure 20



# Starting and Stopping the Engine

## Starting the Engine

**Note:** The glow plug light illuminates for 6 seconds when you turn the ignition key to the RUN position. Turn the ignition to the START position after the light goes out.

**Important:** Use starting cycles of no more than 15 seconds per minute to avoid overheating the starter motor.

**Important:** When you start the engine for the first time, change the engine oil or overhaul the engine, transmission, or wheel motor and operate the machine with the throttle lever in the SLOW position in both the forward and reverse directions for 1 to 2 minutes. Operate the lift lever and PTO lever to ensure that they operate properly. Shut the engine off, check fluid levels, and check for oil leaks, loose parts, and any other noticeable malfunctions.

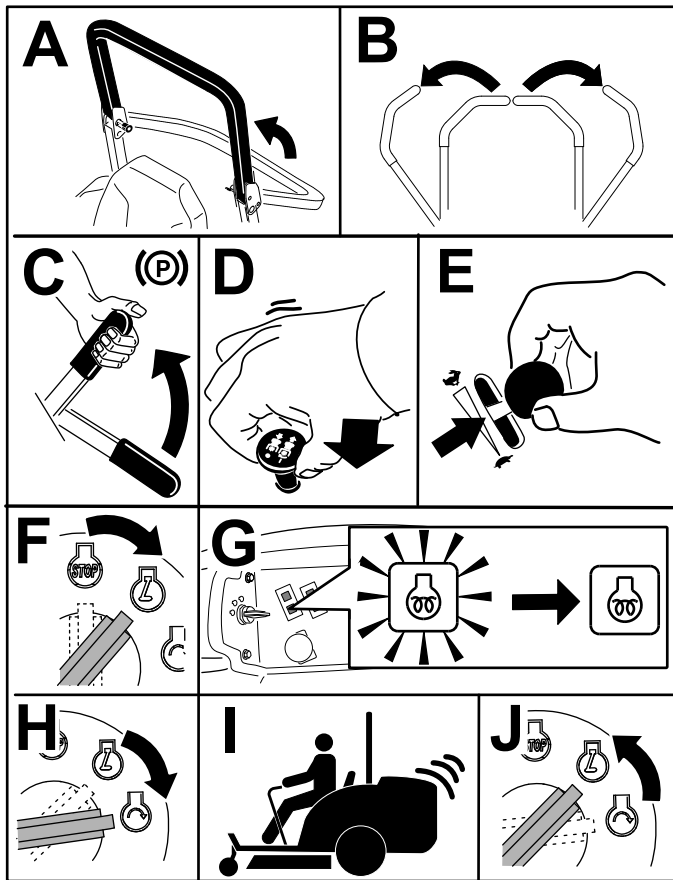


Figure 21

**Note:** Leave the throttle midway between the SLOW and FAST positions until the engine and hydraulic system warm up.

## Stopping the Engine

### ⚠ CAUTION

Children or bystanders may be injured if they attempt to move or operate the tractor while it is unattended.

Always remove the ignition key and set the parking brake when leaving the machine unattended, even if just for a few minutes.

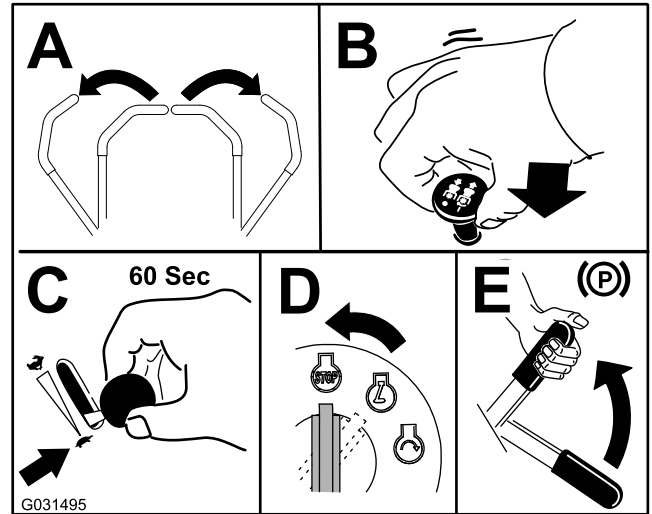


Figure 22

## Driving the Machine

The throttle control regulates the engine speed as measured in rpm (revolutions per minute). Place the throttle control in the FAST position for best performance. Always operate in the FAST throttle position when running powered attachments.

### ⚠ CAUTION

The machine can turn very rapidly. You may lose control of it and cause personal injury or damage the machine.

- Use caution when making turns.
- Slow the machine down before making sharp turns.

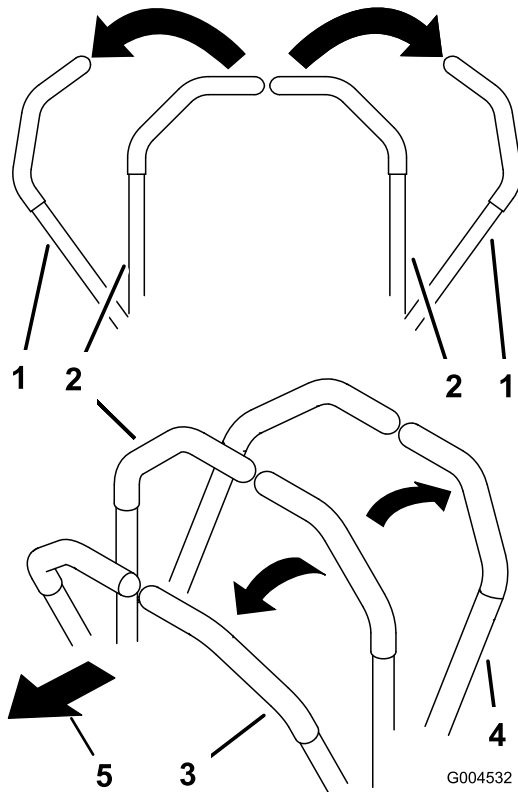
1. Release the parking brake.

**Note:** The engine shuts off if you move the motion-control levers out of the NEUTRAL-LOCK position with the parking brake engaged.

2. Move the levers to the center, unlocked position.
3. Drive the machine as follows:
  - To move straight forward, slowly push the motion-control levers forward (Figure 23).

- To move straight rearward, slowly pull the motion-control levers rearward (Figure 23).
- To turn, slow the machine by pulling back on both levers and then push forward on the lever on the opposite side from which you want to turn (Figure 23).
- To stop, pull the motion-control levers to the NEUTRAL position.

**Note:** The farther you move the motion-control levers in either direction, the faster the machine moves in that direction.



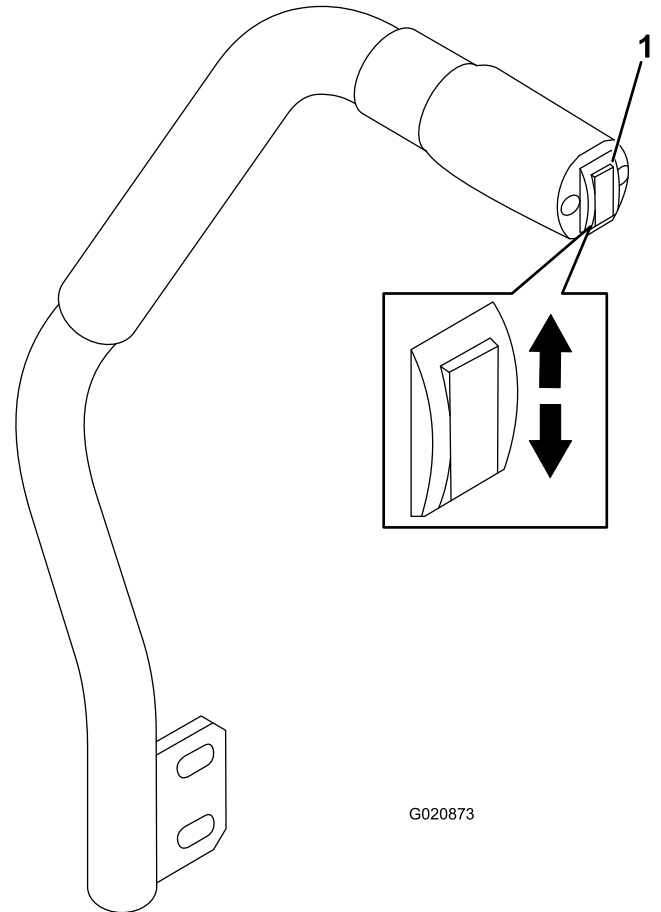
**Figure 23**

- |   |             |
|---|-------------|
| 1. Motion-control lever—NEUTRAL-LOCK position | 3. Forward  |
| 2. Center, unlocked position                  | 4. Backward |

## Operating the Mower

### Using the Deck-Lift Switch

The deck-lift switch raises and lowers the mower deck (Figure 24). The engine must be running for you to use this lever.



**Figure 24**

1. Deck-lift switch

- To lower the mower deck, push the deck-lift switch down (Figure 24).

**Important:** When you lower the mower deck, it sets in a float/idle position.

- To raise the mower deck, push the deck-lift switch up (Figure 24).

**Important:** Do not continue to hold the switch up or down after the mower has fully raised or lowered. Doing so damages the hydraulic system.

## Engaging the Power Takeoff (PTO)

The power-takeoff (PTO) switch starts and stops the mower blades and some powered attachments.

**Note:** If the engine is cold, allow the engine to warm up 5 to 10 minutes before engaging the PTO.

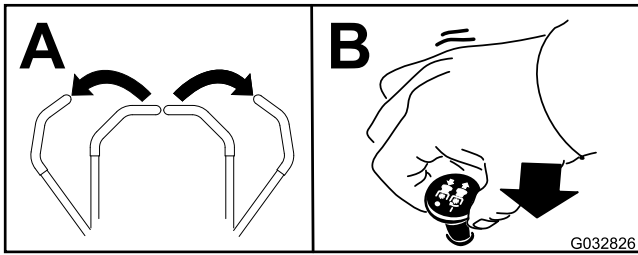
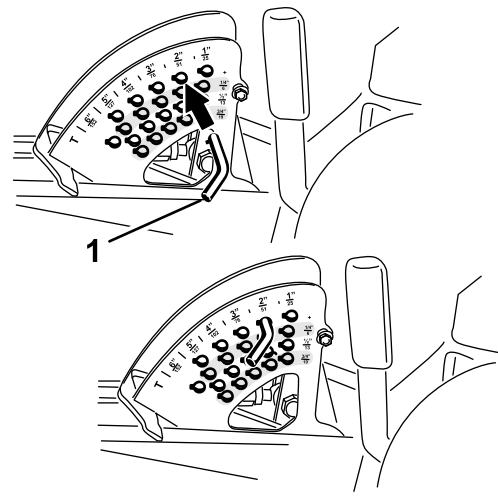


Figure 25



## Disengaging the PTO

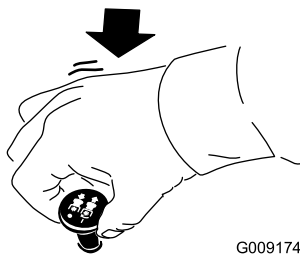


Figure 26



Figure 27

1. Stop pin
  2. Height-of-cut stop
- 
4. Adjust the anti-scalp rollers and skids as required.

## Adjusting the Height of Cut

You can adjust the height of cut from 2.5 to 15.8 cm (1 to 6 inches) in 6 mm (1/4 inch) increments by relocating the stop pin into different hole locations.

1. With the engine running, push the deck-lift switch up until the mower deck is fully raised and **release the switch immediately** (Figure 24).
2. Rotate the stop pin until the roll pin in it lines up with the slots in the holes in the height-of-cut bracket and remove it (Figure 27).
3. Select a hole in the height-of-cut bracket corresponding to the height of cut desired, insert the pin, and rotate it down to lock it in place (Figure 27).

**Note:** There are 4 rows of hole positions (Figure 27). The top row gives you the height of cut listed above the pin. The second row down gives you the height listed plus 6 mm (1/4 inch). The third row down gives you the height listed plus 12 mm (1/2 inch). The bottom row gives you the height listed plus 18 mm (3/4 inch). For the 15.8 cm (6 inch) position, there is only 1 hole, located in the second row. This does not add 6 mm (1/4 inch) to the 15.8 cm (6 inch) position.

## Operating Tips

### Fast Throttle Setting/Ground Speed

To maintain enough power for the machine and deck while mowing, operate the engine at the FAST throttle position and adjust your ground speed for conditions. Decrease the ground speed as the load on the cutting blades increase; increase the ground speed as the load on the blades decrease.

### Mowing Direction

Alternate mowing direction to avoid making ruts in the turf over time. This also helps disperse clippings, which enhances decomposition and fertilization.

### Cutting Speed

To improve cut quality, use a slower ground speed in certain conditions.

### Avoid Cutting Too Low

If the cutting width of the mower is wider than the mower you previously used, raise the cutting height to ensure that uneven turf is not cut too short.

## Select the Proper Height-of-Cut Setting

Remove approximately 25 mm (1 inch) or no more than 1/3 of the grass blade when cutting. In exceptionally lush and dense grass, you may have to slow down the forward speed and/or raise the height of cut to the next higher setting.

**Important:** If you are cutting more than 1/3 of the grass blade off or mowing in sparse long grass or dry conditions, the use flat sail blades to reduce airborne chaff, debris, and deck-drive component strain.

## Cutting Long Grass

If the grass ever grows slightly longer than normal, or if it contains a high degree of moisture, raise the cutting height higher than usual and cut the grass at this setting. Then cut the grass again using the lower, normal setting.

## Keeping the Mower Clean

Clean clippings and dirt from the underside of the mower after each use. If grass and dirt build up inside the mower, cutting quality eventually becomes unsatisfactory.

To reduce the risk of fire hazard, keep the engine, muffler, battery compartment, parking brake, cutting units, and fuel storage compartment free of grass, leaves, or excessive grease. Clean up any spilled oil or fuel.

## Maintaining the Blade

Maintain a sharp blade throughout the cutting season, because a sharp blade cuts cleanly without tearing or shredding the grass blades. Tearing and shredding turns grass brown at the edges, which slows growth and increases the chance of disease. Check the blades daily for sharpness and for any wear or damage. Sharpen the blades as necessary. If a blade is damaged or worn, replace it immediately with a genuine Toro replacement blade.

# After Operation

## After Operation Safety

### General Safety

- Clean grass and debris from the cutting units, drives, mufflers, and engine to help prevent fires. Clean up oil or fuel spills.
- Shut off the fuel while storing or transporting the machine.
- Disengage the drive to the attachment whenever you are transporting or not using the machine.
- Use full-width ramps for loading the machine into a trailer or truck. Do not exceed a 15° angle between the ramp and the trailer or truck.
- Tie the machine down securely using straps, chains, cable, or ropes. Both front and rear straps should be directed down and outward from the machine.
- Allow the engine to cool before storing the machine in any enclosure.
- Never store the machine or fuel container where there is an open flame, spark, or pilot light, such as on a water heater or on other appliances.

### Towing Safety

- Tow only with a machine that has a hitch designed for towing. Do not attach towed equipment except at the hitch point.
- Follow the manufacturer's recommendation for weight limits for towed equipment and towing on slopes. On slopes, the weight of the towed equipment may cause loss of traction and loss of control.
- Never allow children or others in or on towed equipment.
- Travel slowly and allow extra distance to stop when towing.

## Pushing the Machine by Hand

**Important:** Never tow the machine because hydraulic damage may occur.

### Pushing the Machine

1. Disengage the power takeoff (PTO) and turn the ignition key to off. Move the levers to the NEUTRAL-LOCK position and apply the parking brake. Remove the key.
2. Lift the seat.
3. Rotate each bypass valve counterclockwise 1 turn (Figure 28).

**Note:** This allows hydraulic fluid to bypass the pump enabling the wheels to turn.

**Important:** Do not rotate the bypass valves more than 1 turn. This prevents valves from coming out of the body and causing fluid to run out.

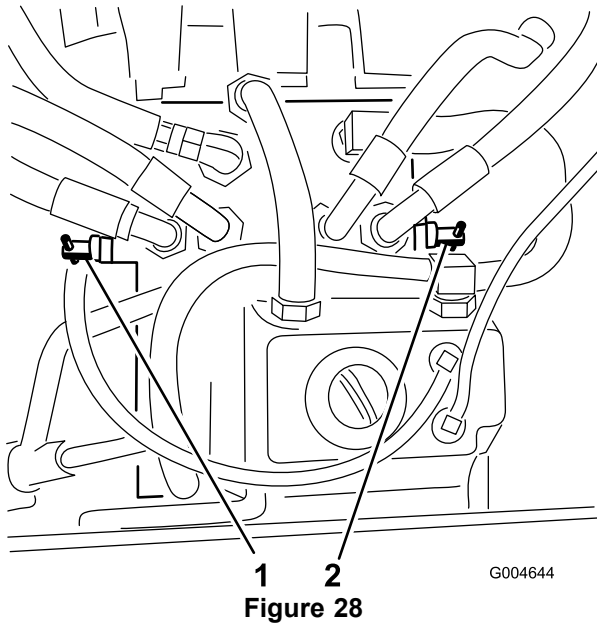


Figure 28

1. Right bypass valve
2. Left bypass valve

4. Disengage the parking brake before pushing.

## Changing to Machine Operation

Rotate each bypass valve clockwise 1 turn and hand-tighten them (Figure 28).

**Note:** The torque should be approximately 8 N·m (71 in-lb). Do not overtighten the bypass valves.

You cannot drive the machine unless the bypass valves are turned inward.

## Loading the Machine

Use extreme caution when loading units on trailers or trucks. One full-width ramp that is wide enough to extend beyond the rear tires is recommended instead of individual ramps for each side of the unit (Figure 29). The lower rear section of the tractor frame extends back between the rear wheels and serves as a stop for tipping backward. Having a full-width ramp provides a surface for the frame members to contact if the unit starts to tip backward. If it is not possible to use one full-width ramp, use enough individual ramps to simulate a full-width continuous ramp.

The ramp should be long enough so that the angles do not exceed 15 degrees (Figure 29). A steeper angle may cause mower components to get caught as the unit moves from ramp to trailer or truck. Steeper angles may also cause the unit to tip backward. If loading on or near a slope, position the trailer or truck so it is on the down side of the slope and the ramp extends up the slope. This will minimize the ramp angle. The trailer or truck should be as level as possible.

**Important:** Do not attempt to turn the unit while on the ramp; you may lose control and drive off the side.

Avoid sudden acceleration when driving up a ramp and sudden deceleration when backing down a ramp. Both maneuvers can cause the unit to tip backward.

### ⚠ WARNING

Loading a unit onto a trailer or truck increases the possibility of backward tip-over and could cause serious injury or death.

- Use extreme caution when operating a unit on a ramp.
- Use only a single, full-width ramp; Do not use individual ramps for each side of the unit.
- If individual ramps must be used, use enough ramps to create an unbroken ramp surface wider than the unit.
- Do not exceed a 15 degree angle between ramp and ground or between ramp and trailer or truck.
- Avoid sudden acceleration while driving unit up a ramp to avoid tipping backward.
- Avoid sudden deceleration while backing unit down a ramp to avoid tipping backward.

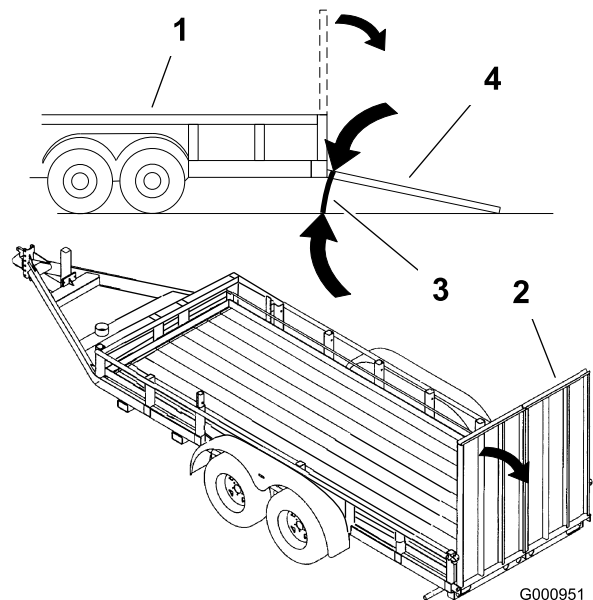


Figure 29

1. Trailer
2. Full-width ramp
3. Not greater than 15 degrees
4. Full-width ramp—side view

# Transporting the Machine

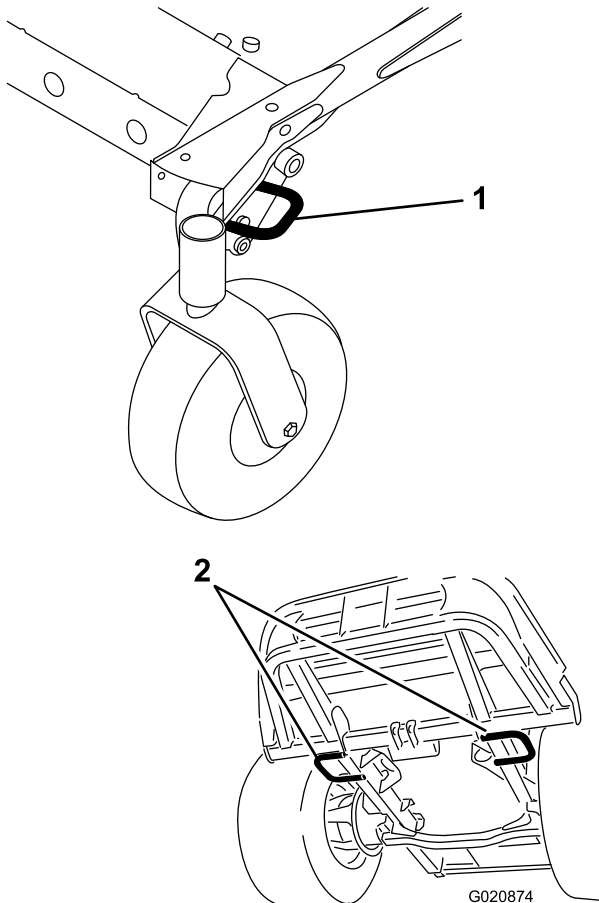
## ⚠ WARNING

Driving on the street or roadway without turn signals, lights, reflective markings, or a slow-moving vehicle emblem is dangerous and can lead to accidents, causing personal injury.

**Do not drive the machine on a public street or roadway without signs, lights, and/or markings required by local regulations.**

Use a heavy-duty trailer or truck to transport the machine. Ensure that the trailer or truck has all the necessary lighting and marking as required by law. Please carefully read all the safety instructions. Knowing this information could help you or bystanders avoid injury.

1. Ensure that your vehicle, hitch, safety chains, and trailer are adequate for the load you are pulling and that they meet all local traffic regulations for your area.
2. Lock the brake and block the wheels.
3. Securely fasten the machine to the trailer or truck with straps, chains, cable, or ropes as required by local traffic regulations in your area (Figure 30).



**Figure 30**

1. Front tie-down loop (left side shown)
2. Rear tie-down loops

# Maintenance

**Note:** Determine the left and right sides of the machine from the normal operating position.

## Recommended Maintenance Schedule(s)

Maintenance Service Interval	Maintenance Procedure
After the first 10 hours	<ul style="list-style-type: none"> <li>• Torque the frame-mounting bolts.</li> <li>• Torque the wheel lug nuts.</li> </ul>
After the first 50 hours	<ul style="list-style-type: none"> <li>• Change the mower-deck gearbox lubricant.</li> <li>• Change the engine oil and filter.</li> </ul>
After the first 200 hours	<ul style="list-style-type: none"> <li>• Change the hydraulic fluid and filter.</li> </ul>
Before each use or daily	<ul style="list-style-type: none"> <li>• Test the safety-interlock system.</li> <li>• Check the engine oil level.</li> <li>• Check the engine coolant level.</li> <li>• Clean the radiator with compressed air (more often in dirty and dusty conditions).</li> <li>• Check the hydraulic fluid level.</li> <li>• Clean the mower deck.</li> </ul>
Every 50 hours	<ul style="list-style-type: none"> <li>• Grease the bearing and bushing grease fittings (more often in dirty or dusty conditions and after every washing).</li> <li>• Check the battery cable connections.</li> <li>• Check the tire pressure.</li> </ul>
Every 100 hours	<ul style="list-style-type: none"> <li>• Check the alternator-belt tension.</li> </ul>
Every 150 hours	<ul style="list-style-type: none"> <li>• Check the lubricant in the mower-deck gearbox.</li> <li>• Change the engine oil and filter.</li> </ul>
Every 200 hours	<ul style="list-style-type: none"> <li>• Inspect the cooling-system hoses and seals. Replace them if cracked or torn.</li> <li>• Torque the wheel lug nuts.</li> </ul>
Every 400 hours	<ul style="list-style-type: none"> <li>• Change the mower-deck gearbox lubricant.</li> <li>• Service the air cleaner.</li> <li>• Replace the fuel-filter canister for the water separator.</li> <li>• Drain water or other contaminants from the water separator.</li> <li>• Check the fuel lines and connections.</li> </ul>
Every 800 hours	<ul style="list-style-type: none"> <li>• Change the hydraulic fluid and filter.</li> <li>• Inspect the engine-valve clearance. Refer to your engine owner's manual.</li> </ul>
Every 1,500 hours	<ul style="list-style-type: none"> <li>• Replace moving hoses.</li> </ul>
Every 2 years	<ul style="list-style-type: none"> <li>• Drain and clean the fuel tank.</li> <li>• Flush and replace the cooling-system fluid.</li> </ul>

**Important:** Refer to your engine owner's manual for additional maintenance procedures. A detailed Service Manual is also available for purchase from your Authorized Toro Distributor.

# Daily Maintenance Checklist

Duplicate this page for routine use.

Maintenance Check Item	For the week of:						
	Mon.	Tues.	Wed.	Thurs.	Fri.	Sat.	Sun.
Check the safety-interlock operation.							
Check the grass deflector in the down position (if applicable).							
Check the parking-brake operation.							
Check the fuel level.							
Check the hydraulic fluid level.							
Check the engine-oil level.							
Check the cooling-system fluid level.							
Check the drain water/fuel separator.							
Check the air-filter restriction indicator. <sup>1</sup>							
Check the radiator and screen for debris							
Check for unusual engine noises. <sup>2</sup>							
Check for unusual operating noises.							
Check the hydraulic hoses for damage							
Check for fluid leaks.							
Check the tire pressure.							
Check the instrument operation.							
Check the condition of the blades.							
Lubricate all grease fittings. <sup>3</sup>							
Touch up damaged paint.							

1. If the indicator shows red
2. Check glow plug and injector nozzles if you notice hard starting, excess smoke, or rough running.
3. Immediately after every washing, regardless of the interval listed.

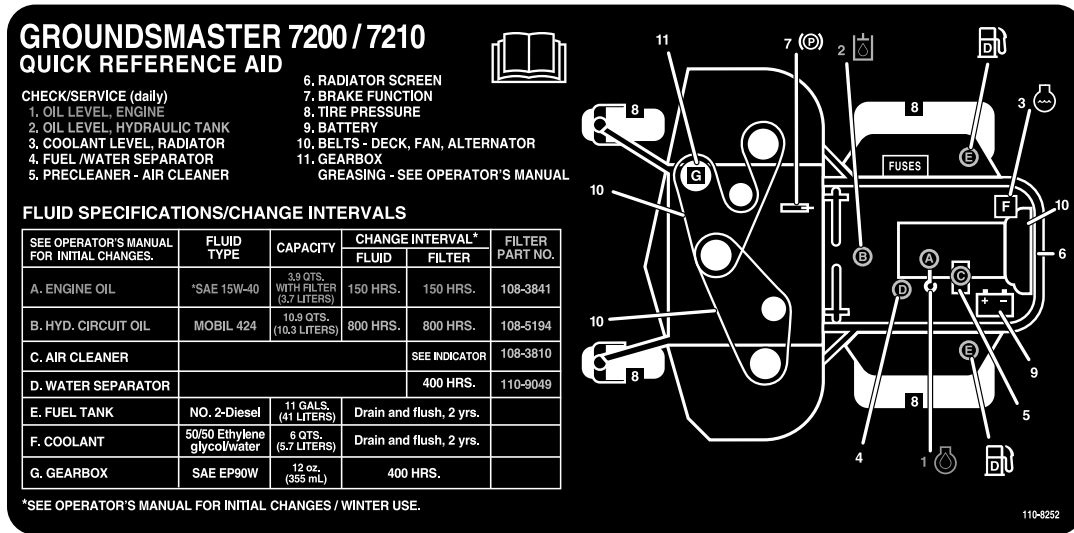
Notation for areas of concern		
Inspection performed by:		
Item	Date	Information



## ⚠ CAUTION

If you leave the key in the ignition switch, someone could accidentally start the engine and seriously injure you or other bystanders.

Remove the key from the ignition before you do any maintenance.



**Figure 31**  
Service Interval Chart

## Premaintenance Procedures

**Important:** The fasteners on the covers of this machine are designed to remain on the cover after removal. Loosen all the fasteners on each cover a few turns so that the cover is loose but still attached, then go back and loosen them until the cover comes free. This prevents you from accidentally stripping the bolts free of the retainers.

## Pre-Maintenance Safety

- Keep all parts of the machine in good working condition and all hardware tightened, especially blade-attachment hardware. Replace all worn or damaged decals.
- Never allow untrained personnel to service the machine.
- Before adjusting, cleaning, or repairing the machine, do the following:
  1. Move the machine to level ground.
  2. Disengage the drives.
  3. Lower the cutting units.
  4. Move the traction pedal to the NEUTRAL position.
  5. Engage the parking brake.
  6. Move the throttle switch to the LOW-IDLE position.

7. Shut off the engine and remove the key.
8. Wait for all moving parts to stop.

- Whenever you park or store the machine, or leave it unattended, lower the cutting units unless you use a positive mechanical lock.
- If possible, do not perform maintenance on the machine while the engine is running. If you must run the engine to perform maintenance on the machine, keep your hands, feet, other body parts, and clothing away from all moving parts, the mower-discharge area, and the underside of the mowers.
- Do not touch parts of the machine or an attachment that may be hot from operation. Allow the parts to cool before attempting to maintain, adjust, or service them.
- Use jack stands to support the machine and/or its components when required.
- Carefully release pressure from components with stored energy.
- If your machine requires major repairs or if you desire assistance, contact an Authorized Toro Distributor.
- Use only genuine Toro replacement parts and accessories. Replacement parts and accessories made by other manufacturers could be dangerous, and such use could void the product warranty.

## Unlatching the Seat

To access the hydraulic and other systems under the seat, unlatch the seat and swing it forward.

1. Use the seat-position adjustment lever to slide the seat all the way forward.
2. Pull the seat latch lever forward and lift up to unlatch the seat ([Figure 32](#)).

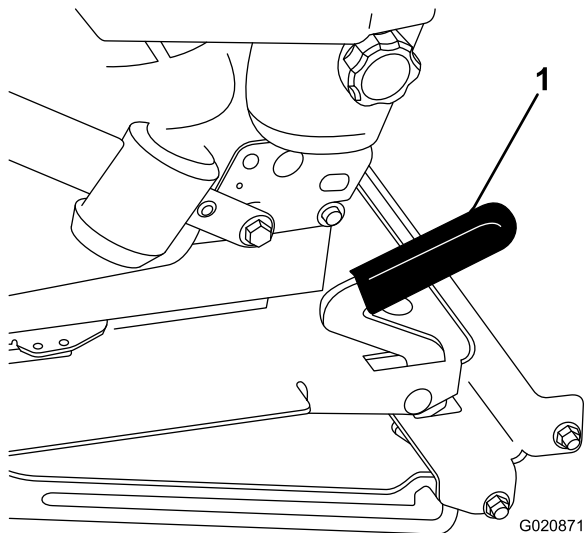


Figure 32

1. Seat latch

## Lubrication

### Greasing the Bearings and Bushings

**Service Interval:** Every 50 hours (more often in dirty or dusty conditions and after every washing).

The machine has grease fittings that you must lubricate regularly with No. 2 lithium grease. Lubricate more often in dirty or dusty conditions because dirt can get into the bearings and bushings and cause accelerated wear.

1. Wipe the grease fittings clean so that foreign matter cannot be forced into the bearing or bushing.
2. Pump grease into the fittings.
3. Wipe off excess grease.

**Note:** Improper wash-down procedures can negatively affect bearing life. Do not wash down the machine when it is still hot and avoid directing high-pressure or high-volume spray at the bearings or seals.

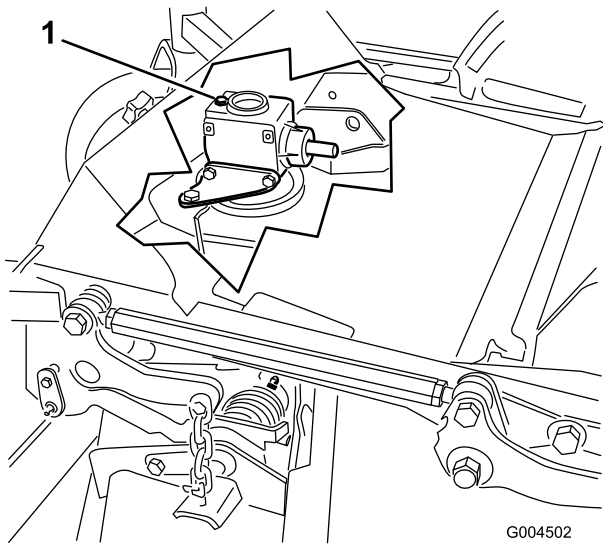
### Servicing the Mower-Deck Gear Box Lubricant

The gear box is designed to operate with SAE EP90W gear lube. Although the gear box comes from the factory with lubricant, check the level of the lubricant in the cutting unit before operating it and as recommended in the [Daily Maintenance Checklist](#) (page 32).

### Checking the Mower-Deck Gearbox Lubricant

**Service Interval:** Every 150 hours

1. Position the machine and mower deck on a level surface.
2. Lower the mower deck to the 2.5 cm (1 inch) height of cut.
3. Disengage the PTO, move the motion-control levers to the NEUTRAL-LOCK position, and set the parking brake.
4. Move the throttle lever to the SLOW position, shut off the engine, remove the key, and wait for all moving parts to stop before leaving the operating position.
5. Lift the footrest, exposing the top of the mower deck.
6. Remove the dipstick/fill plug from the top of the gearbox and make sure that the lubricant is between the marks on the dipstick ([Figure 33](#)).



**Figure 33**

1. Fill plug and dipstick

7. If the lubricant level is low, add enough lubricant until the level is between the marks on the dipstick.

**Important:** Do not overfill the gearbox; overfilling the gearbox may damage it.

## Changing the Mower-Deck Gearbox Lubricant

**Service Interval:** After the first 50 hours

Every 400 hours

1. Position the machine and cutting unit on a level surface.
2. Lower the mower deck to the 2.5 cm (1 inch) height of cut.
3. Disengage the PTO, move the motion-control levers to the NEUTRAL-LOCK position, and set the parking brake.
4. Move the throttle lever to the SLOW position, shut off the engine, remove the key, and wait for all moving parts to stop before leaving the operating position.
5. Lift the footrest, exposing the top of the mower deck.
6. Remove the dipstick/fill plug from the top of the gearbox (Figure 33).
7. Place a funnel and drain pan under the drain plug located under the front of the gearbox and remove the plug, draining the lubricant into the pan.
8. Replace the drain plug.
9. Add enough lubricant, approximately 283 ml (12 oz), until the level is between the marks on the dipstick.

**Important:** Do not overfill the gearbox; overfilling the gearbox may damage it.

# Engine Maintenance

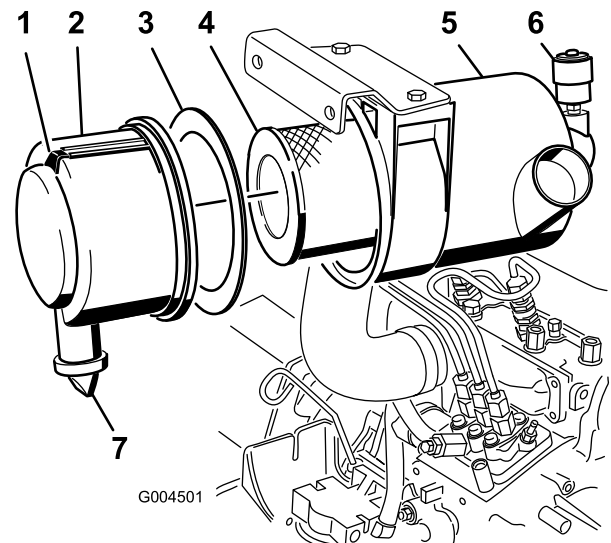
## Engine Safety

Shut off the engine before checking the oil or adding oil to the crankcase.

## Checking the Air Cleaner

1. Check the air-cleaner body for damage, which could possibly cause an air leak. Replace a damaged air-cleaner body.
2. Check the air-intake system for leaks, damage, or loose hose clamps.
3. Service the air-cleaner filter when the air-cleaner indicator shows red or every 400 hours and service it more frequently in extremely dusty or dirty conditions (Figure 34).

**Important:** Do not over-service the air filter.



**Figure 34**

- |                      |                          |
|----------------------|--------------------------|
| 1. Air-cleaner cover | 5. Air-cleaner indicator |
| 2. Gasket            | 6. Air-cleaner latch     |
| 3. Filter            | 7. Rubber outlet valve   |
| 4. Air-cleaner body  |                          |

4. Be sure that the cover is seated correctly and seals with the air-cleaner body.

## Servicing the Air Cleaner

**Service Interval:** Every 400 hours

**Note:** If the foam gasket in the cover is damaged, replace it.

**Important:** Avoid using high-pressure air, which could force dirt through the filter into the intake tract.

**Important:** Do not clean the used filter to avoid damage to the filter media.

**Important:** Do not use a damaged filter.

**Important:** Do not apply pressure to the flexible center of the filter.

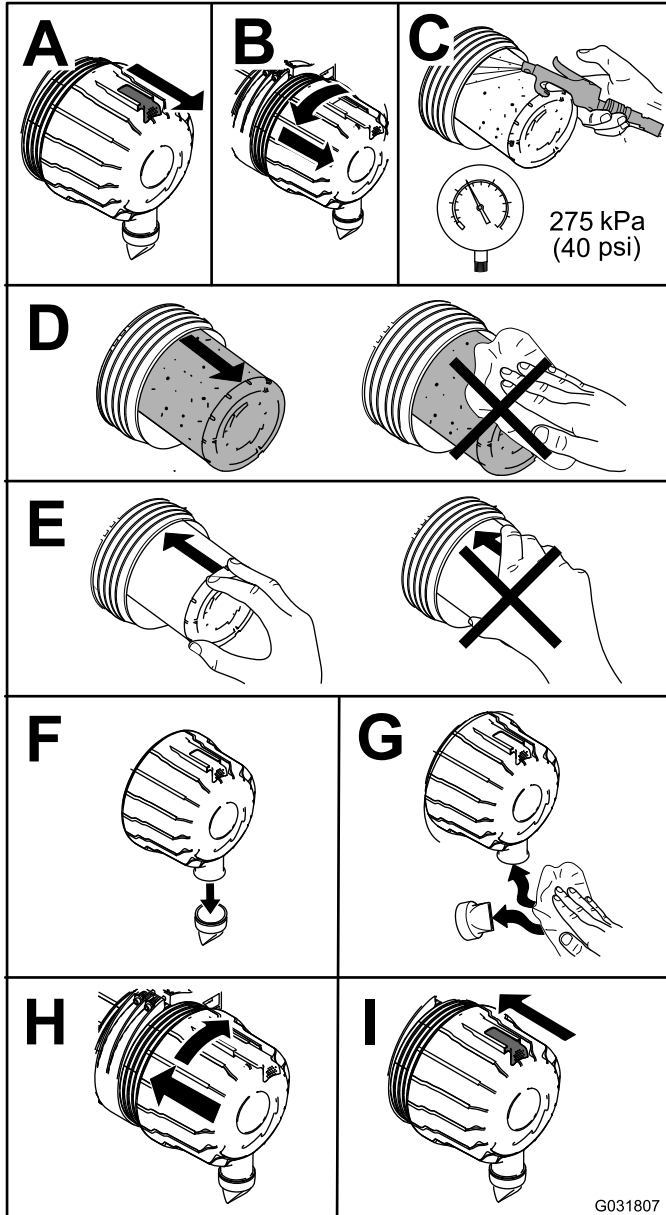


Figure 35

## Servicing the Engine-Oil

### Checking the Engine-Oil Level

**Service Interval:** Before each use or daily

The engine is shipped with oil in the crankcase; however, check the oil level before and after you first start the engine. Check the oil level before operating the machine each day or each time you use the machine.

The crankcase capacity is approximately 3.8 L(4 quarts) with the filter. Use high-quality engine oil that meets the following specifications:

- API Classification Level Required: CH-4, CI-4 or higher.
- Preferred oil: SAE 15W-40 (above 0°F (-17°C))
- Alternate oil: SAE 10W-30 or 5W-30 (all temperatures)

**Note:** Toro Premium Engine oil is available from your distributor in either 15W-40 or 10W-30 viscosity. See the parts catalog for part numbers.

1. Park the machine on a level surface, lower the mower deck, move the throttle lever to the SLOW position, shut off the engine, and remove the key from the ignition switch.
2. Open the hood.
3. Check the engine oil

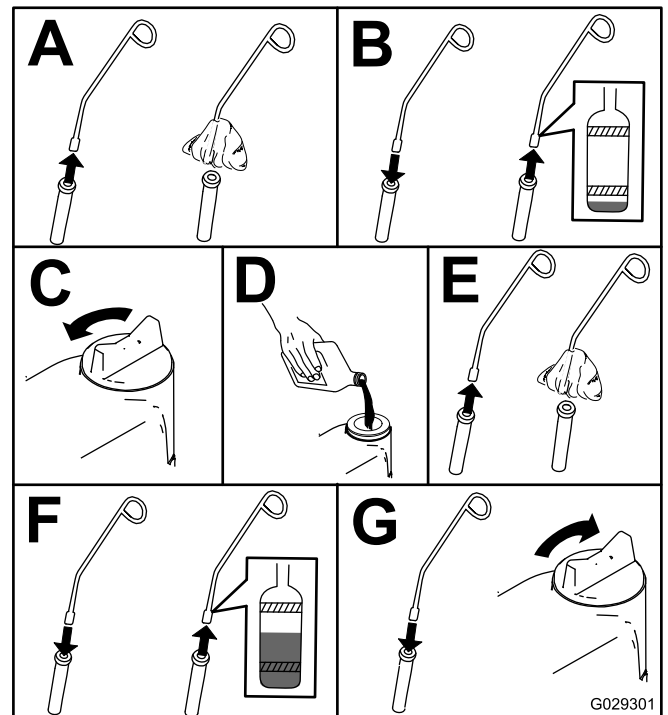


Figure 36

# Changing the Engine Oil And Filter

**Service Interval:** After the first 50 hours

Every 150 hours

If possible, run the engine just before changing the oil because warm oil flows better and carries more contaminants than cold oil.

1. Position the machine on a level surface.
2. Open the hood.
3. Change the oil ([Figure 37](#)).

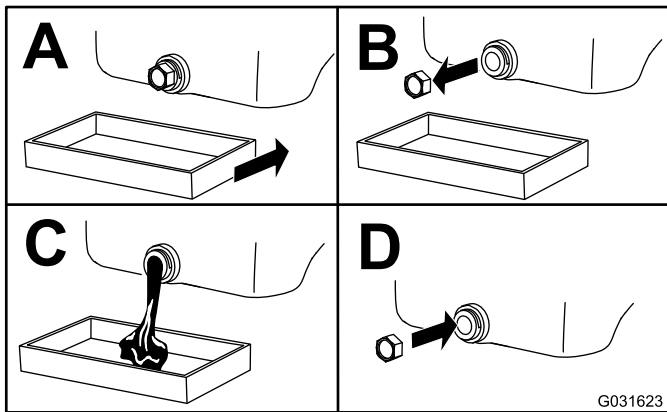


Figure 37

4. Replace the oil filter ([Figure 38](#)).

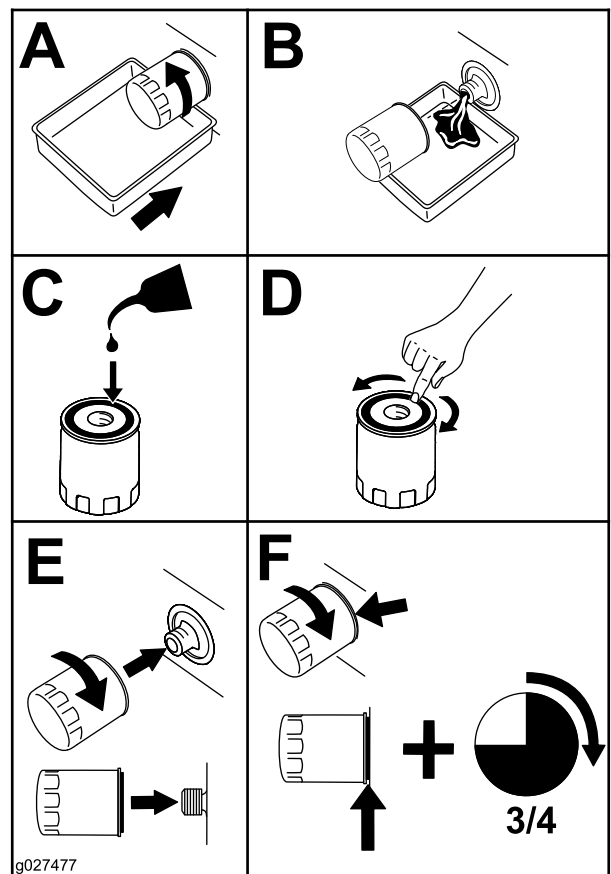


Figure 38

5. Fill the crankcase with oil; refer to [Checking the Engine-Oil Level](#) (page 36).

# Fuel System Maintenance

## **⚠ DANGER**

Under certain conditions, diesel fuel and fuel vapors are highly flammable and explosive. A fire or explosion from fuel can burn you and others and can cause property damage.

- Use a funnel and fill the fuel tank outdoors, in an open area, when the engine is off and is cold. Wipe up any fuel that spills.
- Do not fill the fuel tank completely full. Add fuel to the fuel tank until the level is to the bottom of the filler neck.
- Never smoke when handling fuel, and stay away from an open flame or where fuel fumes may be ignited by a spark.
- Store fuel in a clean, safety-approved container and keep the cap in place.

# Servicing the Water Separator

Service Interval: Every 400 hours

Every 400 hours

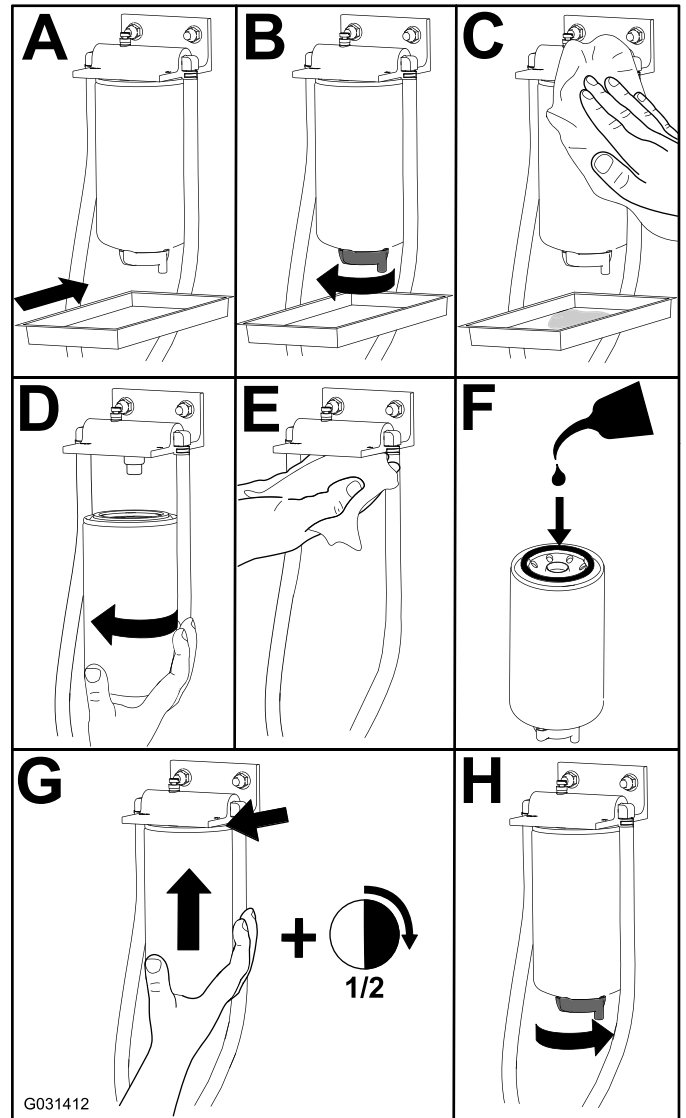


Figure 39

# Cleaning the Fuel Tank

Service Interval: Every 2 years

Remove and clean the in-line strainers after draining the tank. Use clean diesel fuel to flush out the tank.

**Important:** Drain and clean the tank if the fuel system becomes contaminated or if you are storing the machine for an extended period.

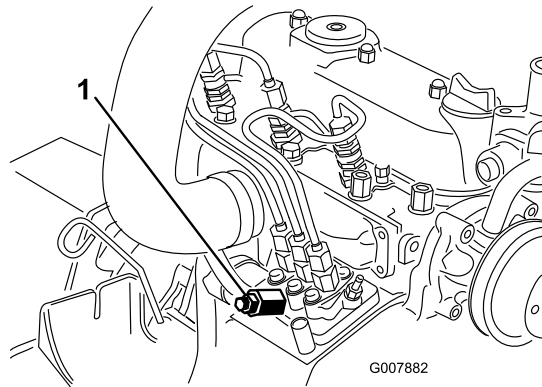
# Checking the Fuel Lines and Connections

**Service Interval:** Every 400 hours

Inspect the fuel lines for deterioration, damage, chaffing, or loose connections.

## Bleeding the Fuel System

1. Park the machine on a level surface. Ensure that the fuel tank is at least half full.
2. Unlatch and raise the hood.
3. Place a rag under the air-bleed screw on the fuel-injection pump and open it (Figure 40).



**Figure 40**

1. Fuel-injection-pump bleed screw

4. Turn the ignition key to the ON position.

**Note:** The electric fuel pump begins operation, thereby forcing air out at the air-bleed screw.

### **CAUTION**

**The engine may start during this procedure. Moving fans and belts in a running engine can severely injure you or bystanders.**

**Keep hands, fingers, loose clothing/jewelry, and hair away from the engine fan and belt during this procedure.**

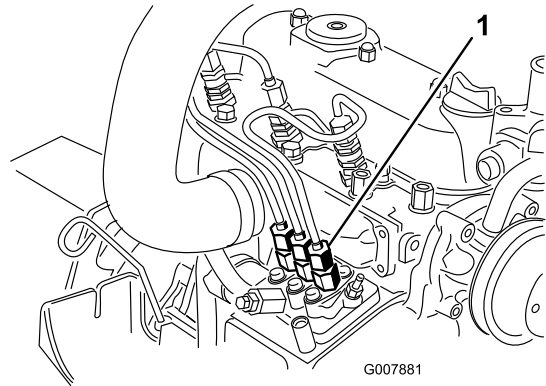
5. Leave the key in the ON position until a solid stream of fuel flows out around the screw.
6. Tighten the screw and turn key to the OFF position.

**Note:** Normally, the engine should start after you bleed the fuel system. However, if engine does not start, air may be trapped between injection pump and injectors; refer to [Bleeding Air from the Injectors](#) (page 39).

## Bleeding Air from the Injectors

**Note:** Use this procedure only if you purged the fuel system through normal priming procedures and the engine does not start; refer to [Bleeding the Fuel System](#) (page 39).

1. Place a rag under the pipe connection coming from the injection pump to the No. 1 injector nozzle as illustrated in Figure 41.



**Figure 41**

1. Pipe connection from the injection pump to the No. 1 injector nozzle

2. Move the throttle to the FAST position.
3. Turn the ignition key the START position and watch the fuel flow around the connector.

### **CAUTION**

**The engine may start during this procedure. Moving fans and belts in a running engine can severely injure you or bystanders.**

**Keep hands, fingers, loose clothing/jewelry, and hair away from the engine fan and belt during this procedure.**

4. Tighten the pipe connector securely when it attains a solid flow.
5. Turn the key to the OFF position.
6. Repeat this procedure for the remaining nozzles.



# Electrical System Maintenance

## Electrical System Safety

- Disconnect the battery before repairing the machine. Disconnect the negative terminal first and the positive last. Connect the positive terminal first and the negative last.
- Battery acid is poisonous and can cause burns. Avoid contact with your skin, eyes, and clothing. Protect your face, eyes, and clothing when working with a battery.
- Battery gases can explode. Keep cigarettes, sparks, and flames away from the battery.
- Charge the batteries in an open, well-ventilated area, away from sparks and flames. Unplug the charger before connecting or disconnecting the battery. Wear protective clothing and use insulated tools.
- Do not use a pressure washer near any electronic components.

### WARNING

#### CALIFORNIA Proposition 65 Warning

Battery posts, terminals, and related accessories contain lead and lead compounds, chemicals known to the State of California to cause cancer and reproductive harm.  
Wash hands after handling.

## Servicing the Battery

**Service Interval:** Every 50 hours

If you store the machine in a location where temperatures are extremely high, the battery runs down more rapidly than if the machine is stored in a location where the temperature is cool.

Keep the top of the battery clean by washing it periodically with a brush dipped in ammonia or bicarbonate soda solution. Flush the top surface with water after cleaning it.

**Important:** Do not remove the fill caps while cleaning the battery.

The battery cables must be tight on the terminals to provide good electrical contact.

If corrosion occurs at the terminals, disconnect the cables, negative (-) cable first, and scrape the clamps and terminals separately. Connect the cables, positive (+) cable first, and coat the terminals with petroleum jelly.

### ⚠ WARNING

Battery terminals or metal tools could short against metal machine components, causing sparks. Sparks can cause the battery gasses to explode, resulting in personal injury.

- When removing or installing the battery, do not allow the battery terminals to touch any metal parts of the machine.
- Do not allow metal tools to short between the battery terminals and metal parts of the machine.

### ⚠ WARNING

Incorrect battery cable routing could damage the machine and cables, causing sparks. Sparks can cause the battery gasses to explode, resulting in personal injury.

- Always disconnect the negative (black) battery cable before disconnecting the positive (red) cable.
- Always connect the positive (red) battery cable before connecting the negative (black) cable.

## Storing the Battery

If you are storing the machine more than 30 days, remove the battery and charge it fully. Either store it on a shelf or on the machine. Do not connect the cables if you store it on the machine. Store the battery in a cool environment to prevent the battery from discharging rapidly. To prevent the battery from freezing, make sure it is fully charged. The specific gravity of a fully charged battery is 1.265 to 1.299.

## Checking the Fuses

The fuses are located under the control panel. Access them through the side panel cover (Figure 42). To open the side panel cover, release the 2 latches and pull out on it.

If the machine stops or has other electrical system issues, check the fuses. Grasp each fuse in turn and remove them 1 at a time, checking if any are blown.

**Important:** If you need to replace a fuse, always use the same type and amperage-rated fuse as the one you are replacing, otherwise you could damage the electrical system. Refer to the decal next to the fuses for a diagram of each fuse and its amperage (Figure 43).

**Note:** If a fuse blows frequently, you probably have a short in the electrical system and should have it serviced by a qualified service technician.



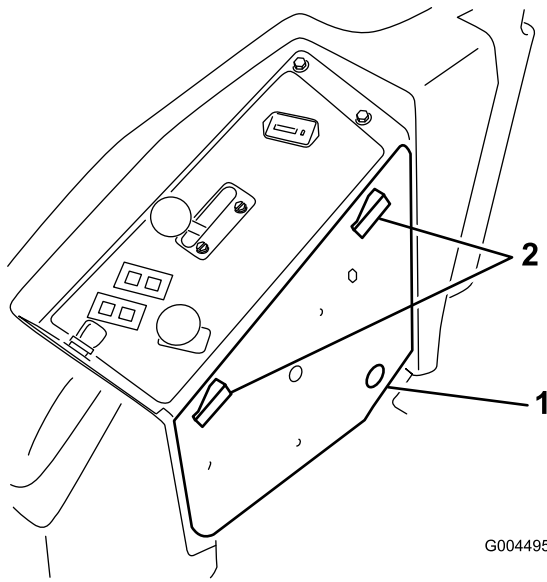
# Drive System Maintenance

## Checking the Tire Pressure

**Service Interval:** Every 50 hours

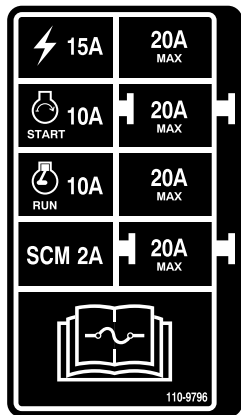
Check the pressure after every 50 operating hours or monthly, whichever occurs first (Figure 44).

Maintain the air pressure in the front and rear tires. The correct air pressure is 124 kPa (15 psi) in the rear tires and 103 kPa (25 psi) in the caster wheels. Uneven tire pressure can cause an uneven cut. Check the tires when they are cold to get the most accurate pressure reading.

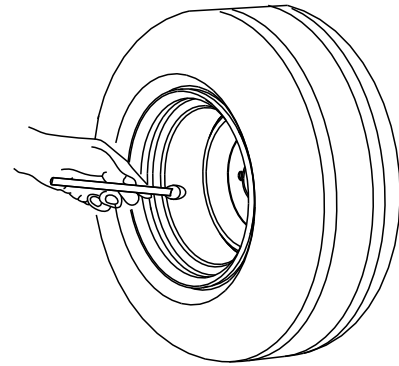


**Figure 42**

1. Side panel cover      2. Latch



**Figure 43**



**Figure 44**

# Replacing the Caster Wheels and Bearings

1. Obtain a new caster-wheel assembly, cone bearings, and bearing seals from your Authorized Toro Distributor.
2. Remove the locknut from the bolt (Figure 45).

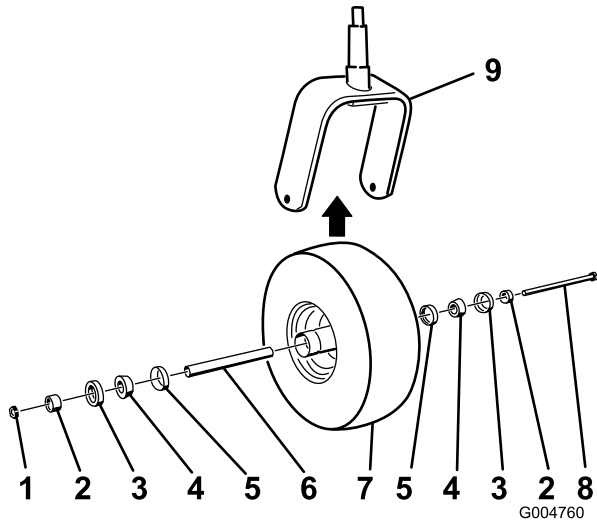


Figure 45

- |                       |                 |
|-----------------------|-----------------|
| 1. Locknut            | 6. Spacer       |
| 2. Bearing spacer     | 7. Caster wheel |
| 3. Outer bearing seal | 8. Axle bolt    |
| 4. Cone bearing       | 9. Caster fork  |
| 5. Inner bearing seal |                 |

3. Grasp the caster wheel and slide the bolt out of the fork or pivot arm.
4. Discard the old caster wheel and bearings.
5. Assemble the caster wheel by pushing the cone bearings and seals, packed with grease, into the wheel hub, positioned as shown in Figure 45.
6. Slide the spacer into the wheel hub through the bearings, captivating the spacer inside the wheel hub with 2 bearing spacers.

**Important:** Ensure that the seal lips are not folded inward.

7. Install the caster-wheel assembly between the castor fork and secure it in place with the bolt and locknut.
8. Tighten the locknut until the wheel no longer spins freely, then back it off just until the wheel spins freely.
9. Attach a grease gun to the grease fitting on the caster wheel and fill it with No. 2 lithium grease.

# Cooling System Maintenance

## Cooling System Safety

### ⚠ CAUTION

Discharge of hot, pressurized coolant or touching a hot radiator and surrounding parts can cause severe burns.

- Do not remove the radiator cap when the engine is hot. Always allow the engine to cool at least 15 minutes or until the radiator cap is cool enough to touch without burning your hand before removing the radiator cap.
- Do not touch the radiator and surrounding parts that are hot.

### ⚠ DANGER

The rotating fan and drive belt can cause personal injury.

- Do not operate the machine without the covers in place.
- Keep your fingers, hands, and clothing clear of the rotating fan and drive belt.
- Shut off the engine and remove the ignition key before performing maintenance.

### ⚠ DANGER

Swallowing engine coolant can cause poisoning.

- Do not swallow engine coolant.
- Keep out of reach from children and pets.

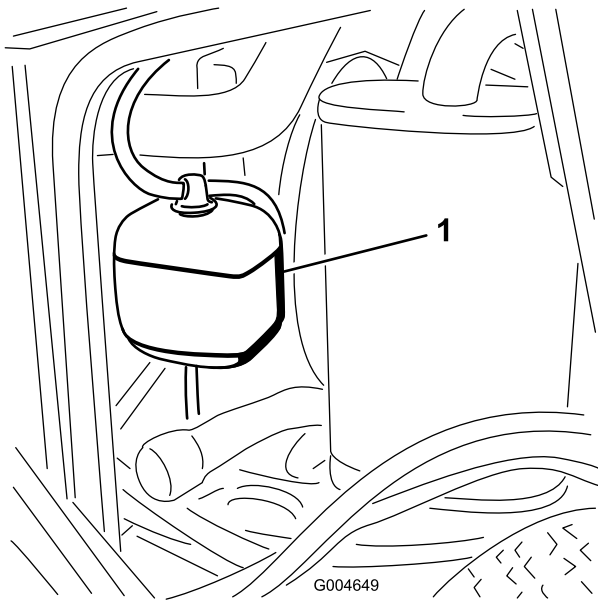
## Checking the Cooling System

**Service Interval:** Before each use or daily

The cooling system is filled with a 50/50 solution of water and permanent ethylene glycol anti freeze. The capacity of the cooling system is 7.5 L (6 US qt).

1. Check the level of the coolant in the expansion tank (Figure 46).

**Note:** The coolant level should be between the marks on the side of the tank.



**Figure 46**

1. Expansion tank

2. If coolant level is low, remove the expansion tank cap and replenish the system.

**Important:** Do not overfill.

3. Install the expansion-tank cap.

## Cleaning the Radiator

**Service Interval:** Before each use or daily

Every 1,500 hours—Replace moving hoses.

Every 200 hours—Inspect the cooling-system hoses and seals. Replace them if cracked or torn.

Every 2 years—Flush and replace the cooling-system fluid.

Clean the radiator to prevent the engine from overheating.

**Note:** If the mower deck or engine shuts off due to overheating, check the radiator for excessive buildup of debris.

Clean the radiator as follows:

1. Open the hood.
2. Working from the fan side of the radiator, blow out debris with low pressure (345 kPa or 50 psi), compressed air. Repeat from the front of the radiator and the other fan side.

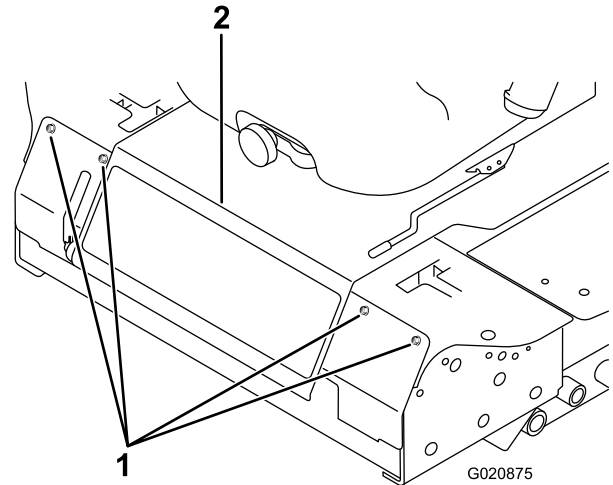
**Important:** Do not use water.

3. After you thoroughly clean the radiator, clean out debris that may have collected in the channel at the radiator base.
4. Close the hood.

## Brake Maintenance

### Adjusting the Parking-Brake Interlock Switch

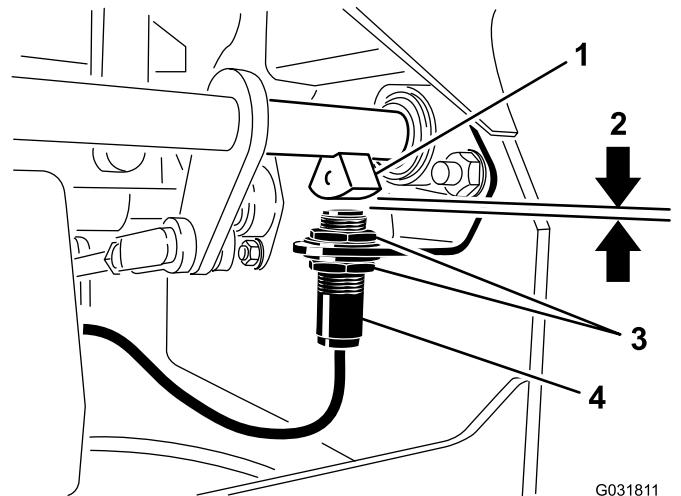
1. Stop the machine, move the motion-control levers to the NEUTRAL-LOCK position, set the parking brake, and remove the ignition key.
2. Remove the bolts securing the front panel and remove the panel (Figure 47).



**Figure 47**

1. Bolt
2. Control panel

3. Loosen the 2 jam nuts securing the parking-brake interlock switch to the mounting bracket.



**Figure 48**

1. Brake-shaft sensor
2. 4 mm (5/32 inch)
3. Jam nut
4. Parking-brake interlock switch

4. Move the switch up or down on the bracket until the distance between the brake-shaft sensor and the switch plunger is 4 mm (5/32 inch) as shown in Figure 48.

**Note:** Make sure that the brake-shaft sensor does not contact the switch plunger.

5. Secure the switch jam nuts.
6. Test the adjustment as follows:
  - A. Ensure that the parking brake is engaged and you are not sitting on the seat, then start the engine.
  - B. Move the control levers out of the NEUTRAL-LOCK position.

**Note:** The engine should stop. If not, check the adjustment that you made to the switch.

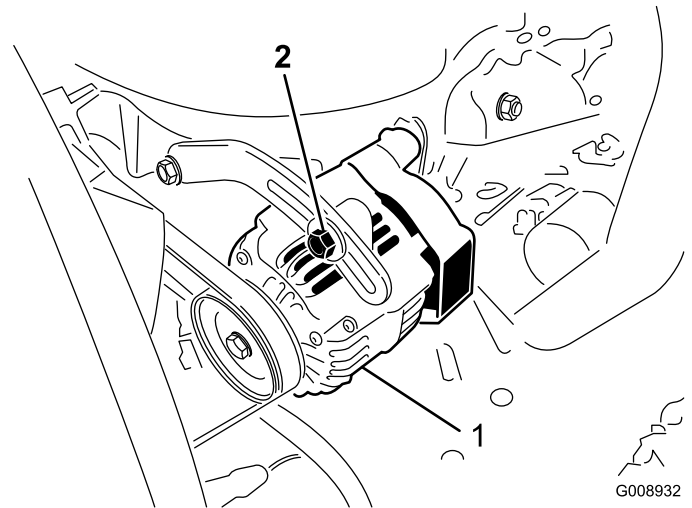
7. Install the front panel.

## Belt Maintenance

### Checking the Alternator-Belt Tension

**Service Interval:** Every 100 hours

1. Apply 44 N (10 lb) of force to the alternator belt, midway between the pulleys.
2. If the deflection is not 10 mm (3/8 inch), loosen the alternator mounting bolts (Figure 49).



**Figure 49**

1. Mounting bolt
2. Alternator

- 
3. Increase or decrease the alternator-belt tension.
  4. Tighten the mounting bolts.
  5. Check the deflection of the belt again to ensure that the tension is correct.

# Controls System Maintenance

## Adjusting the Control-Lever Neutral-Interlock Switch

1. Stop the machine, move the motion-control levers to the NEUTRAL-LOCK position, set the parking brake, and remove the ignition key.
2. Remove the bolts securing the front panel and remove the panel (Figure 50).

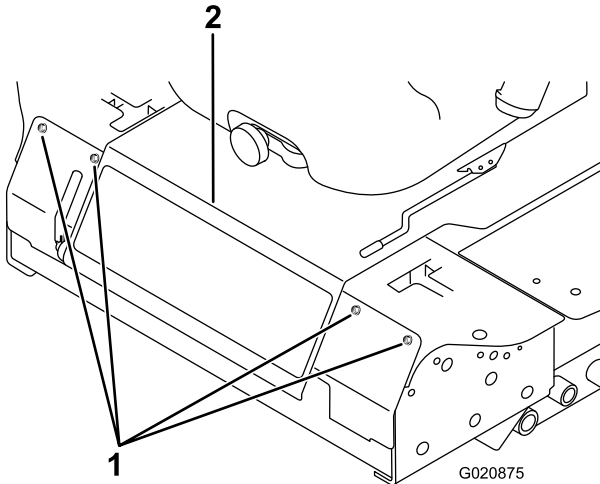


Figure 50

1. Bolt
2. Control panel

3. Loosen the 2 screws securing the interlock switch (Figure 51).

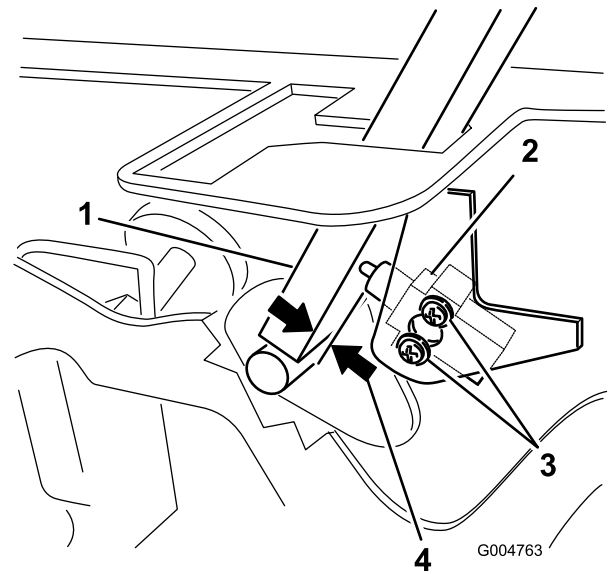


Figure 51

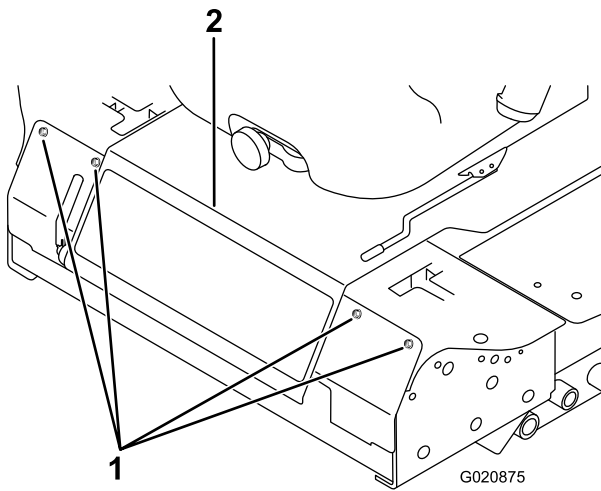
1. Control lever
2. Neutral-interlock switch
3. Screw
4. 0.4 to 1 mm (0.015 to 0.045 inch)

4. Holding the control lever against the frame, move the switch toward the lever until the distance between the lever and switch body is 0.4 to 1 mm (0.015 to 0.045 inch) as shown in Figure 51.
5. Secure the switch.
6. Repeat steps 3 to 5 for the other lever.
7. Install the front panel.

## Adjusting the Control-Lever Neutral Return

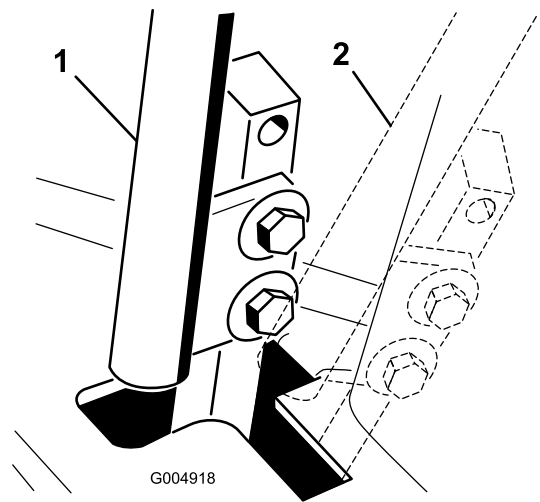
If the motion-control levers do not align with the neutral slots when released from the REVERSE position, adjustment is required. Adjust each lever, spring, and rod separately.

1. Disengage the PTO, move the control lever to the NEUTRAL-LOCK position, and set the parking brake.
2. Move the throttle lever to the SLOW position, shut off the engine, remove the key, and wait for all moving parts to stop before leaving the operating position.
3. Remove the bolts securing the front panel and remove the panel (Figure 52).



**Figure 52**

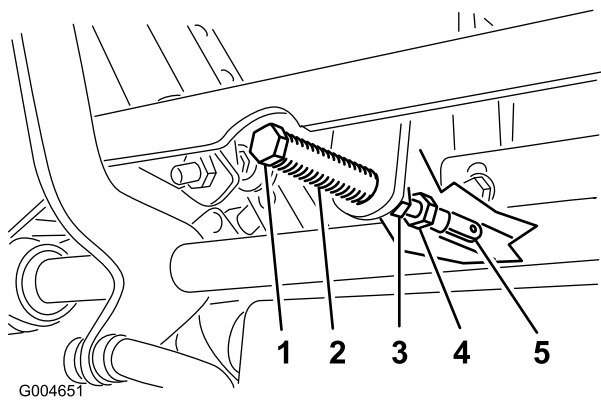
1. Bolt
2. Control panel



**Figure 54**

1. NEUTRAL position
2. NEUTRAL-LOCK position

4. Move the control lever to the NEUTRAL position but **not locked** (Figure 54).
5. Pull the lever back until the clevis pin (on an arm above the pivot shaft) contacts the end of the slot (just beginning to put pressure on the spring) as shown in Figure 53.



**Figure 53**

1. Clevis pin
2. Slot
3. Jam nut
4. Adjustment bolt
5. Yoke

6. Check where the control lever is relative to notch in the console (Figure 54).

**Note:** The control lever should be centered, allowing lever to pivot outward to the NEUTRAL-LOCK position.

7. If adjustment is needed, loosen the nut and jam nut against the yoke (Figure 53).
  8. Applying slight rearward pressure on the motion-control lever, turn the head of the adjustment bolt in the appropriate direction until the control lever is centered in the NEUTRAL-LOCK position (Figure 53).
- Note:** Rearward pressure on the lever keeps the pin at the end of the slot and allow the adjustment bolt to move the lever to the appropriate position.
9. Tighten the nut and jam nut (Figure 53).
  10. Repeat steps 4 through 9 for the other control lever.
  11. Install the front panel.

## Adjusting the Traction Drive for Neutral

Make this adjustment with the drive wheels turning.

### **⚠ DANGER**

Mechanical or hydraulic jacks may fail to support the machine and cause a serious injury.

- Use jack stands when supporting the machine.
- Do not use hydraulic jacks.

### **⚠ WARNING**

The engine must be running to perform this adjustment. Contact with moving parts or hot surfaces may cause personal injury.

Keep hands, feet, face, clothing, and other body parts away from rotating parts, muffler, and other hot surfaces.

1. Raise the frame onto stable jack stands so that the drive wheels can rotate freely.
2. Slide the seat forward, unlatch it, and swing it up and forward.
3. Disconnect the electrical connector from the seat safety switch.
4. Temporarily install a jumper wire across the terminals in the wire harness connector.
5. Start the engine, ensure that the throttle lever is midway between the FAST and SLOW positions, and release the parking brake.

**Note:** The motion-control levers must be in the NEUTRAL-LOCK position while you make any adjustments.

6. Adjust the pump rod length on one side by rotating the hex shaft, in the appropriate direction, until the corresponding wheel is still or slightly creeping in reverse (Figure 55).

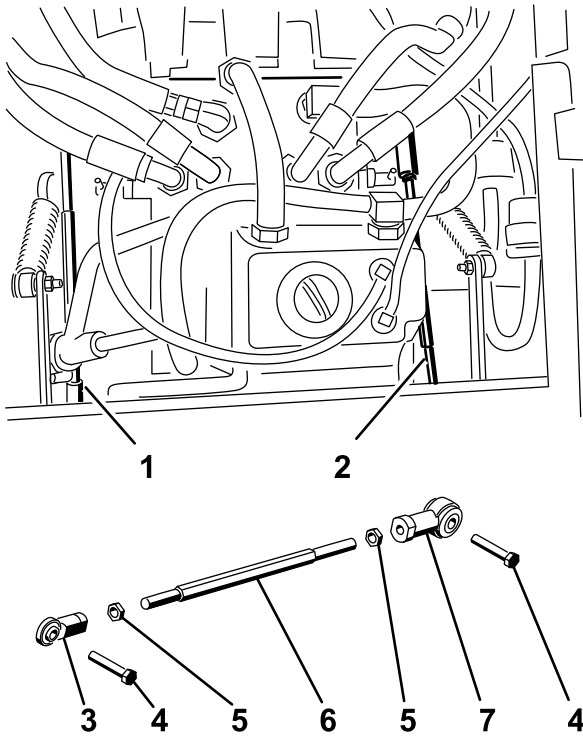


Figure 56

**Figure 55**

- |                   |               |
|-------------------|---------------|
| 1. Right pump rod | 5. Jam nut    |
| 2. Left pump rod  | 6. Hex shaft  |
| 3. Ball joint     | 7. Ball joint |
| 4. Bolt           |               |

7. Move the motion-control lever forward and reverse, then back to neutral.

**Note:** The wheel must stop turning or slightly creep in reverse.

8. Move the throttle lever to the FAST position.

**Note:** Make sure that the wheel remains stopped or slightly creeps in reverse; adjust it if necessary.

9. Repeat steps 6 through 8 for the other side of the machine.
10. Tighten the jam nuts at the ball joints (Figure 53).
11. Move the throttle lever to the SLOW position and shut off the engine.
12. Remove the jumper wire from the wire harness connector and plug the connector into the seat switch.

### ⚠ WARNING

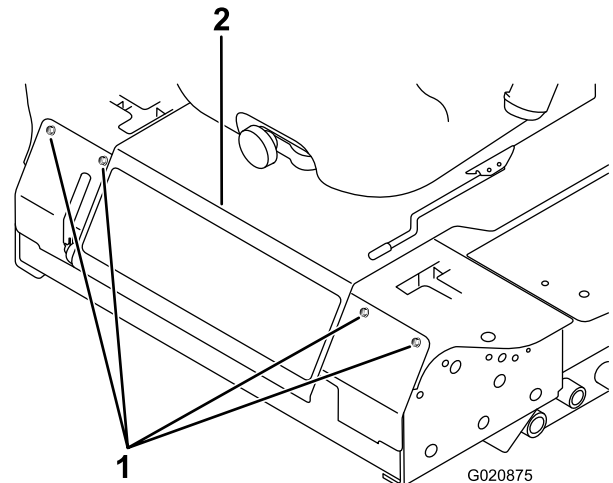
The electrical system does not perform proper safety shutoff with the jumper wire installed.

- Remove the jumper wire from the wire harness connector and plug the connector into the seat switch when you complete adjustment.
- Never operate the machine with the jumper installed and the seat switch bypassed.

13. Lower the seat into position.
14. Remove the jack stands.

## Adjusting the Maximum Ground Speed

1. Disengage the PTO, move the motion-control levers to the NEUTRAL-LOCK position, and set the parking brake.
2. Move the throttle lever to the SLOW position, shut off the engine, remove the key, and wait for all moving parts to stop before leaving the operating position.
3. Remove the bolts securing the front panel and remove the panel (Figure 56).

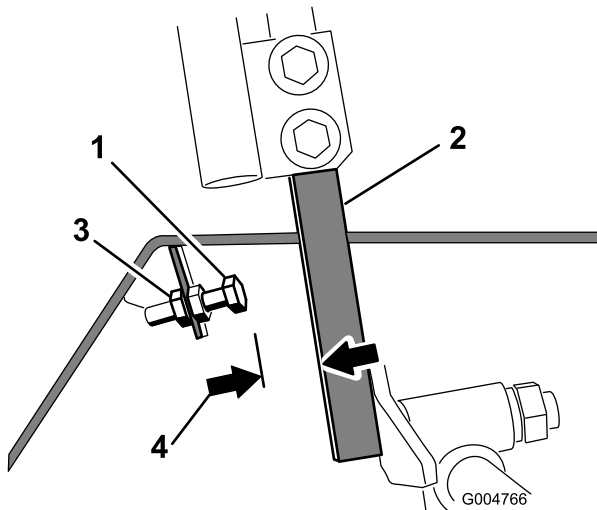


**Figure 56**

1. Bolt
2. Control panel



- Loosen the jam nut on the stop bolt for a control lever (Figure 57).



**Figure 57**

- |                  |                        |
|------------------|------------------------|
| 1. Stop bolt     | 3. Jam nut             |
| 2. Control lever | 4. 1.5 mm (0.060 inch) |

- Thread the stop bolt all the way in (away from the control lever).
- Push the control lever all the way forward until it stops and hold it there.
- Thread the stop bolt out (toward the control lever) until there is a gap of 1.5 mm (0.060 inch) between the head of the stop bolt and the control lever.

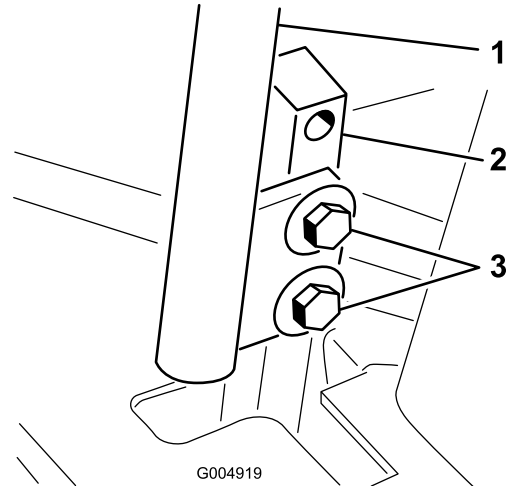
**Note:** If you want to reduce the maximum machine speed, back each stop bolt out an equal amount toward the control lever until you reach the desired maximum speed. You may need to test your adjustment several times.

- Tighten the jam nut to secure the stop bolt in place.
- Repeat steps 4 through 8 for the other control lever.
- Install the front panel.
- Ensure that the machine drives straight and does not turn when both control levers are pushed all the way forward.

**Note:** If the machine turns, the stop bolts are not evenly set and you need to adjust them further.

## Adjusting the Tracking

- Disengage the PTO, move the motion-control levers to the NEUTRAL-LOCK position, and set the parking brake.
- Move the throttle lever to the SLOW position, shut off the engine, remove the key, and wait for all moving parts to stop before leaving the operating position.
- Loosen the bolts securing the control levers (Figure 58)



**Figure 58**

- |                       |          |
|-----------------------|----------|
| 1. Control lever      | 3. Bolts |
| 2. Control-lever post |          |

- Have someone push the control-lever posts (not the control levers) all the way forward into the maximum-speed position and hold them there.
- Adjust the control levers so that they line up and tighten the bolts, securing the levers to the posts (Figure 59).



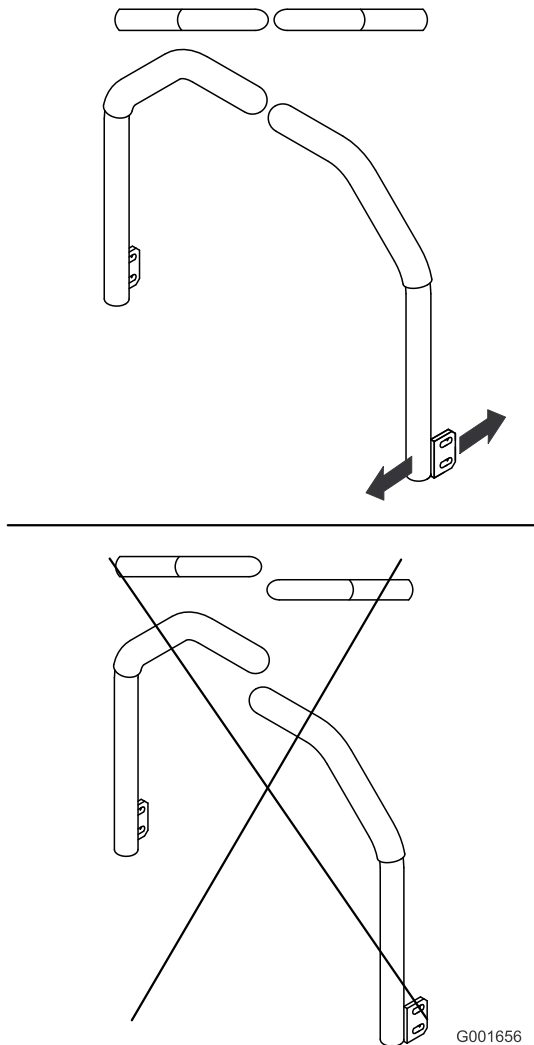


Figure 59

G001656

# Hydraulic System Maintenance

The reservoir is filled at the factory with approximately 4.7 L (5 quarts) of high-quality tractor transmission/hydraulic fluid. The recommended replacement fluid is as follows:

**Toro Premium Transmission/Hydraulic Tractor Fluid**  
(Available in 5 gallon pails or 55 gallon drums. See parts catalog or Toro distributor for part numbers.)

Alternate fluids: If the Toro fluid is not available, Mobil® 424 hydraulic fluid may be used.

**Note:** Toro will not assume responsibility for damage caused by improper substitutions.

**Note:** Many hydraulic fluids are almost colorless, making it difficult to spot leaks. A red dye additive for the hydraulic system fluid is available in 20 ml (2/3 fl oz) bottles. One bottle is sufficient for 15 to 22 L (4 to 6 gallons) of hydraulic fluid. Order part number 44-2500 from your Authorized Toro Distributor.

## Hydraulic System Safety

### ⚠ WARNING

Hydraulic fluid escaping under pressure can penetrate skin and cause injury.

- Ensure that all hydraulic-fluid hoses and lines are in good condition and all hydraulic connections and fittings are tight before applying pressure to the hydraulic system.
- Keep your body and hands away from pinhole leaks or nozzles that eject high-pressure hydraulic fluid.
- Use cardboard or paper to find hydraulic leaks.
- Safely relieve all pressure in the hydraulic system before performing any work on the hydraulic system.
- Seek immediate medical attention if fluid is injected into skin.

## Checking the Hydraulic System

**Service Interval:** Before each use or daily

Check the level of the hydraulic fluid before you first start the engine and daily thereafter.

1. Position the machine on a level surface.
2. Move the motion-control levers to the NEUTRAL-LOCK position and start the engine.

**Note:** Run the engine at the lowest possible rpm to purge the system of air.

**Important:** Do not engage the PTO.

3. Raise the deck to extend the lift cylinders, shut off the engine, and remove the key.
4. Raise the seat to access the hydraulic fluid tank.
5. Remove the hydraulic fill cap from the filler neck (Figure 60).

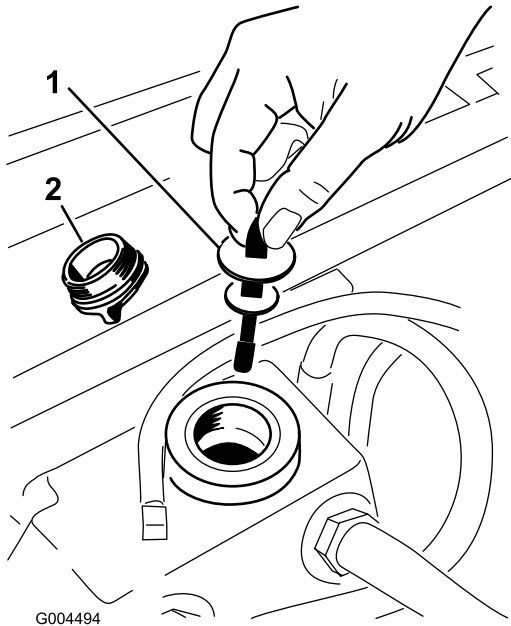


Figure 60

1. Dipstick
2. Fill cap

6. Remove the dipstick and wipe it with a clean rag (Figure 60).
7. Place the dipstick into the filler neck; then remove it and check the level of fluid (Figure 60).

**Note:** If the level is not within the notched area of the dipstick, add enough high-quality hydraulic fluid to raise the level to within the notched area.

**Important:** Do not overfill.

8. Replace the dipstick and thread the fill cap finger-tight onto the filler neck.
9. Check all hoses and fittings for leaks.

## Changing the Hydraulic Fluid And Filter

**Service Interval:** After the first 200 hours

Every 800 hours

1. Disengage the PTO, move the motion-control levers to the NEUTRAL-LOCK position, and set the parking brake.
2. Move the throttle lever to the SLOW position, shut off the engine, remove the key, and wait for all moving parts to stop before leaving the operating position.
3. Place a large pan under the hydraulic reservoir and transmission case and remove the plugs, draining all of the hydraulic fluid (Figure 61).

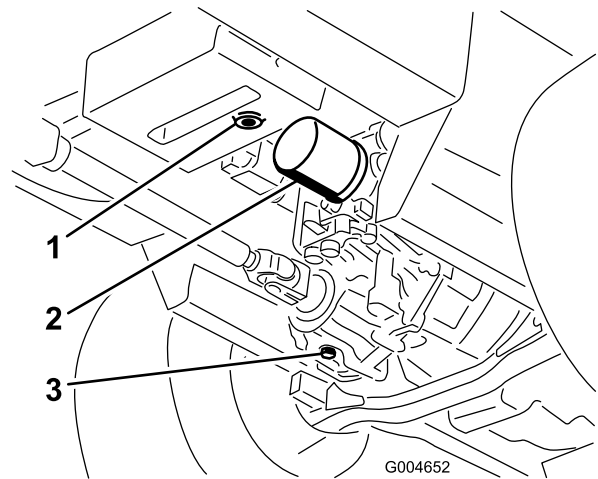


Figure 61

1. Hydraulic-reservoir drain plug
2. Filter
3. Transmission-case drain plug

4. Clean the area around the hydraulic fluid filter and remove the filter (Figure 61).
5. Immediately install a new hydraulic fluid filter.
6. Install the hydraulic-reservoir and transmission-case drain plugs.
7. Fill the reservoir to the proper level (approximately 5.7 L or 6 US qt); refer to [Checking the Hydraulic System \(page 49\)](#).
8. Start the engine and check for oil leaks. Allow the engine to run for about 5 minutes, then shut it off.
9. After 2 minutes, check the level of the hydraulic fluid; refer to [Checking the Hydraulic System \(page 49\)](#).

# Cleaning

## Cleaning Under the Mower

**Service Interval:** Before each use or daily

1. Disengage the PTO, move the motion-control levers to the NEUTRAL-LOCK position, and set the parking brake.
2. Move the throttle lever to the SLOW position, shut off the engine, remove the key, and wait for all moving parts to stop before leaving the operating position.
3. Raise the mower to the transport position.
4. Raise the front of the machine using jack stands.
5. Thoroughly clean the underside of the mower with water.

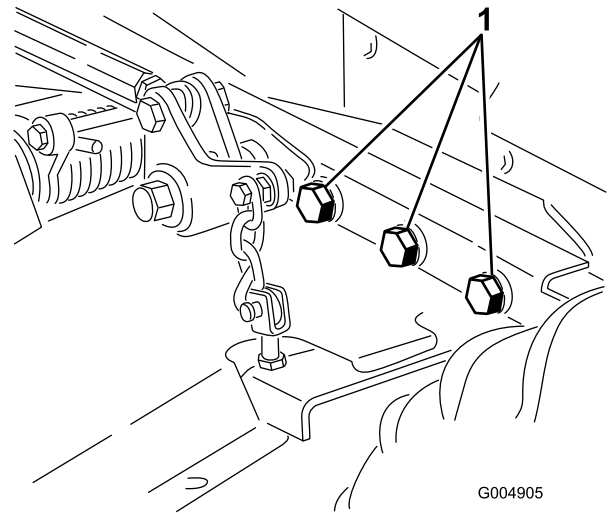
## Disposing of Waste

Engine oil, batteries, hydraulic fluid, and engine coolant are pollutants. Dispose of these according to your state and local regulations.

# Storage

## Machine

1. Thoroughly clean the machine, deck, and engine, paying special attention to these areas:
  - Radiator and radiator screen
  - Underneath the deck
  - Under the deck belt covers
  - Counterbalance springs
  - PTO-shaft assembly
  - All grease fittings and pivot points
  - Inside the control box
  - Beneath the seat plate and top of the transmission
2. Check and adjust front and rear tire pressure; refer to [Checking the Tire Pressure \(page 41\)](#).
3. Remove, sharpen, and balance the mower blades. Install the blades and torque the blade fasteners to 115 to 149 N·m (85 to 110 ft-lb).
4. Check all fasteners for looseness and tighten them as necessary. Torque the 6 bolts securing the mower deck frame to the traction unit ([Figure 62](#)) to 359 N·m (265 ft-lb).



**Figure 62**

Right side not shown.

1. Bolts
- 
5. Grease or oil all grease fittings, pivot points, and transmission-bypass-valve pins. Wipe off any excess lubricant.
  6. Lightly sand and use touch up paint on painted areas that are scratched, chipped or rusted. Repair any dents in the metal body.
  7. Service the battery and cables as follows:
    - A. Remove the battery terminals from the battery posts.

- B. Clean the battery, terminals, and posts with a wire brush and baking soda solution.
- C. Coat the cable terminals and battery posts with Grafo 112X skin-over grease (Toro Part No. 505-47) or petroleum jelly to prevent corrosion.
- D. Slowly recharge the battery for 24 hours every 60 days to prevent lead sulfation of the battery.

## Engine

1. Drain the engine oil from the oil pan and replace the drain plug.
2. Replace the oil filter.
3. Fill the engine with the recommended motor oil.
4. Start the engine and run it at idle speed for 2 minutes.
5. Drain the fuel from the fuel tank, fuel lines, pump, filter, and separator. Flush the fuel tank with clean diesel fuel and connect all fuel lines.
6. Thoroughly clean and service the air-cleaner assembly.
7. Seal the air-cleaner inlet and the exhaust outlet with weather proof masking tape.
8. Check the oil filler cap and fuel-tank cap to ensure that they are securely in place.

**Notes:**

**Notes:**

## International Distributor List

<b>Distributor:</b>	<b>Country:</b>	<b>Phone Number:</b>	<b>Distributor:</b>	<b>Country:</b>	<b>Phone Number:</b>
Agrolanc Kft	Hungary	36 27 539 640	Maquiver S.A.	Colombia	57 1 236 4079
Asian American Industrial (AAI)	Hong Kong	852 2497 7804	Maruyama Mfg. Co. Inc.	Japan	81 3 3252 2285
B-Ray Corporation	Korea	82 32 551 2076	Mountfield a.s.	Czech Republic	420 255 704 220
Brisa Goods LLC	Mexico	1 210 495 2417	Mountfield a.s.	Slovakia	420 255 704 220
Casco Sales Company	Puerto Rico	787 788 8383	Munditol S.A.	Argentina	54 11 4 821 9999
Ceres S.A.	Costa Rica	506 239 1138	Norma Garden	Russia	7 495 411 61 20
CSSC Turf Equipment (pvt) Ltd.	Sri Lanka	94 11 2746100	Oslinger Turf Equipment SA	Ecuador	593 4 239 6970
Cyril Johnston & Co.	Northern Ireland	44 2890 813 121	Oy Hako Ground and Garden Ab	Finland	358 987 00733
Cyril Johnston & Co.	Republic of Ireland	44 2890 813 121	Parkland Products Ltd.	New Zealand	64 3 34 93760
Fat Dragon	China	886 10 80841322	Perfetto	Poland	48 61 8 208 416
Femco S.A.	Guatemala	502 442 3277	Pratoverde SRL.	Italy	39 049 9128 128
FIVEMANS New-Tech Co., Ltd	China	86-10-6381 6136	Prochaska & Cie	Austria	43 1 278 5100
ForGarder OU	Estonia	372 384 6060	RT Cohen 2004 Ltd.	Israel	972 986 17979
G.Y.K. Company Ltd.	Japan	81 726 325 861	Riversa	Spain	34 9 52 83 7500
Geomechaniki of Athens	Greece	30 10 935 0054	Lely Turfcare	Denmark	45 66 109 200
Golf international Turizm	Turkey	90 216 336 5993	Lely (U.K.) Limited	United Kingdom	44 1480 226 800
Hako Ground and Garden	Sweden	46 35 10 0000	Solvart S.A.S.	France	33 1 30 81 77 00
Hako Ground and Garden	Norway	47 22 90 7760	Spypros Stavrinides Limited	Cyprus	357 22 434131
Hayter Limited (U.K.)	United Kingdom	44 1279 723 444	Surge Systems India Limited	India	91 1 292299901
Hydroturf Int. Co Dubai	United Arab Emirates	97 14 347 9479	T-Markt Logistics Ltd.	Hungary	36 26 525 500
Hydroturf Egypt LLC	Egypt	202 519 4308	Toro Australia	Australia	61 3 9580 7355
Irrimac	Portugal	351 21 238 8260	Toro Europe NV	Belgium	32 14 562 960
Irrigation Products Int'l Pvt Ltd.	India	0091 44 2449 4387	Valtech	Morocco	212 5 3766 3636
Jean Heybroek b.v.	Netherlands	31 30 639 4611	Victus Emak	Poland	48 61 823 8369

### European Privacy Notice

#### The Information Toro Collects

Toro Warranty Company (Toro) respects your privacy. In order to process your warranty claim and contact you in the event of a product recall, we ask you to share certain personal information with us, either directly or through your local Toro company or dealer.

The Toro warranty system is hosted on servers located within the United States where privacy law may not provide the same protection as applies in your country.

BY SHARING YOUR PERSONAL INFORMATION WITH US, YOU ARE CONSENTING TO THE PROCESSING OF YOUR PERSONAL INFORMATION AS DESCRIBED IN THIS PRIVACY NOTICE.

#### The Way Toro Uses Information

Toro may use your personal information to process warranty claims, to contact you in the event of a product recall and for any other purpose which we tell you about. Toro may share your information with Toro's affiliates, dealers or other business partners in connection with any of these activities. We will not sell your personal information to any other company. We reserve the right to disclose personal information in order to comply with applicable laws and with requests by the appropriate authorities, to operate our systems properly or for our own protection or that of other users.

#### Retention of your Personal Information

We will keep your personal information as long as we need it for the purposes for which it was originally collected or for other legitimate purposes (such as regulatory compliance), or as required by applicable law.

#### Toro's Commitment to Security of Your Personal Information

We take reasonable precautions in order to protect the security of your personal information. We also take steps to maintain the accuracy and current status of personal information.

#### Access and Correction of your Personal Information

If you would like to review or correct your personal information, please contact us by email at [legal@toro.com](mailto:legal@toro.com).

### Australian Consumer Law

Australian customers will find details relating to the Australian Consumer Law either inside the box or at your local Toro Dealer.



# The Toro Warranty

## A Two-Year Limited Warranty

### Conditions and Products Covered

The Toro Company and its affiliate, Toro Warranty Company, pursuant to an agreement between them, jointly warrant your Toro Commercial product ("Product") to be free from defects in materials or workmanship for two years or 1500 operational hours\*, whichever occurs first. This warranty is applicable to all products with the exception of Aerators (refer to separate warranty statements for these products). Where a warrantable condition exists, we will repair the Product at no cost to you including diagnostics, labor, parts, and transportation. This warranty begins on the date the Product is delivered to the original retail purchaser.

\* Product equipped with an hour meter.

### Instructions for Obtaining Warranty Service

You are responsible for notifying the Commercial Products Distributor or Authorized Commercial Products Dealer from whom you purchased the Product as soon as you believe a warrantable condition exists. If you need help locating a Commercial Products Distributor or Authorized Dealer, or if you have questions regarding your warranty rights or responsibilities, you may contact us at:

Toro Commercial Products Service Department  
Toro Warranty Company  
8111 Lyndale Avenue South  
Bloomington, MN 55420-1196  
952-888-8801 or 800-952-2740  
E-mail: commercial.warranty@toro.com

### Owner Responsibilities

As the Product owner, you are responsible for required maintenance and adjustments stated in your *Operator's Manual*. Failure to perform required maintenance and adjustments can be grounds for disallowing a warranty claim.

### Items and Conditions Not Covered

Not all product failures or malfunctions that occur during the warranty period are defects in materials or workmanship. This warranty does not cover the following:

- Product failures which result from the use of non-Toro replacement parts, or from installation and use of add-on, or modified non-Toro branded accessories and products. A separate warranty may be provided by the manufacturer of these items.
- Product failures which result from failure to perform recommended maintenance and/or adjustments. Failure to properly maintain your Toro product per the Recommended Maintenance listed in the *Operator's Manual* can result in claims for warranty being denied.
- Product failures which result from operating the Product in an abusive, negligent, or reckless manner.
- Parts subject to consumption through use unless found to be defective. Examples of parts which are consumed, or used up, during normal Product operation include, but are not limited to, brake pads and linings, clutch linings, blades, reels, rollers and bearings (sealed or greasable), bed knives, spark plugs, castor wheels and bearings, tires, filters, belts, and certain sprayer components such as diaphragms, nozzles, and check valves, etc.
- Failures caused by outside influence. Conditions considered to be outside influence include, but are not limited to, weather, storage practices, contamination, use of unapproved fuels, coolants, lubricants, additives, fertilizers, water, or chemicals, etc.
- Failure or performance issues due to the use of fuels (e.g. gasoline, diesel, or biodiesel) that do not conform to their respective industry standards.

### Countries Other than the United States or Canada

Customers who have purchased Toro products exported from the United States or Canada should contact their Toro Distributor (Dealer) to obtain guarantee policies for your country, province, or state. If for any reason you are dissatisfied with your Distributor's service or have difficulty obtaining guarantee information, contact the Toro importer.

- Normal noise, vibration, wear and tear, and deterioration.
- Normal "wear and tear" includes, but is not limited to, damage to seats due to wear or abrasion, worn painted surfaces, scratched decals or windows, etc.

### Parts

Parts scheduled for replacement as required maintenance are warranted for the period of time up to the scheduled replacement time for that part. Parts replaced under this warranty are covered for the duration of the original product warranty and become the property of Toro. Toro will make the final decision whether to repair any existing part or assembly or replace it. Toro may use remanufactured parts for warranty repairs.

### Deep Cycle and Lithium-Ion Battery Warranty:

Deep cycle and Lithium-Ion batteries have a specified total number of kilowatt-hours they can deliver during their lifetime. Operating, recharging, and maintenance techniques can extend or reduce total battery life. As the batteries in this product are consumed, the amount of useful work between charging intervals will slowly decrease until the battery is completely worn out. Replacement of worn out batteries, due to normal consumption, is the responsibility of the product owner. Battery replacement may be required during the normal product warranty period at owner's expense. Note: (Lithium-Ion battery only): A Lithium-Ion battery has a part only prorated warranty beginning year 3 through year 5 based on the time in service and kilowatt hours used. Refer to the *Operator's Manual* for additional information.

### Maintenance is at Owner's Expense

Engine tune-up, lubrication, cleaning and polishing, replacement of filters, coolant, and completing recommended maintenance are some of the normal services Toro products require that are at the owner's expense.

### General Conditions

Repair by an Authorized Toro Distributor or Dealer is your sole remedy under this warranty.

**Neither The Toro Company nor Toro Warranty Company is liable for indirect, incidental or consequential damages in connection with the use of the Toro Products covered by this warranty, including any cost or expense of providing substitute equipment or service during reasonable periods of malfunction or non-use pending completion of repairs under this warranty. Except for the Emissions warranty referenced below, if applicable, there is no other express warranty. All implied warranties of merchantability and fitness for use are limited to the duration of this express warranty.**

Some states do not allow exclusions of incidental or consequential damages, or limitations on how long an implied warranty lasts, so the above exclusions and limitations may not apply to you. This warranty gives you specific legal rights, and you may also have other rights which vary from state to state.

### Note regarding engine warranty:

The Emissions Control System on your Product may be covered by a separate warranty meeting requirements established by the U.S. Environmental Protection Agency (EPA) and/or the California Air Resources Board (CARB). The hour limitations set forth above do not apply to the Emissions Control System Warranty. Refer to the Engine Emission Control Warranty Statement supplied with your product or contained in the engine manufacturer's documentation for details