



Count on it.

Operator's Manual

**Greensmaster® 3300 TriFlex®
Traction Unit**

Model No. 04510—Serial No. 316000001 and Up



g014597



This product complies with all relevant European directives; for details, please see the separate product specific Declaration of Conformity (DOC) sheet.

⚠ WARNING

**CALIFORNIA
Proposition 65 Warning**

This product contains a chemical or chemicals known to the State of California to cause cancer, birth defects, or reproductive harm.

The engine exhaust from this product contains chemicals known to the State of California to cause cancer, birth defects, or other reproductive harm.

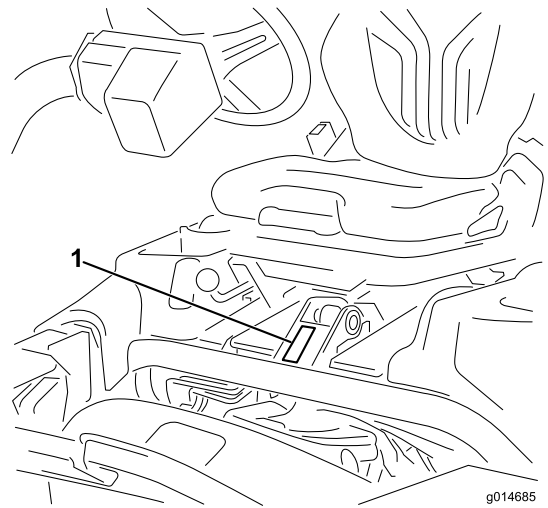

Figure 1

This spark ignition system complies with Canadian ICES-002.

It is a violation of California Public Resource Code Section 4442 or 4443 to use or operate the engine on any forest-covered, brush-covered, or grass-covered land unless the engine is equipped with a spark arrester, as defined in Section 4442, maintained in effective working order or the engine is constructed, equipped, and maintained for the prevention of fire.

Introduction

This machine is a ride-on, reel-blade lawn mower intended to be used by professional, hired operators in commercial applications. It is primarily designed for cutting grass on well-maintained lawns in parks, golf courses, sports fields, and on commercial grounds. It is not designed for cutting brush, mowing grass and other growth alongside highways, or for agricultural uses.

Read this information carefully to learn how to operate and maintain your product properly and to avoid injury and product damage. You are responsible for operating the product properly and safely.

You may contact Toro directly at www.Toro.com for product and accessory information, help finding a dealer, or to register your product.

Whenever you need service, genuine Toro parts, or additional information, contact an Authorized Service Dealer or Toro Customer Service and have the model and serial numbers of your product ready. [Figure 1](#) identifies the location of the model and serial numbers on the product. Write the numbers in the space provided.

1. Model and serial number location

Model No. _____
Serial No. _____

This manual identifies potential hazards and has safety messages identified by the safety-alert symbol ([Figure 2](#)), which signals a hazard that may cause serious injury or death if you do not follow the recommended precautions.



Figure 2

1. Safety-alert symbol

This manual uses 2 words to highlight information. **Important** calls attention to special mechanical information and **Note** emphasizes general information worthy of special attention.

Contents

Safety	4
Safe Operating Practices	4
Toro Mower Safety	5
Sound Power Level	6
Sound Pressure Level	6
Hand-Arm Vibration Level	6
Whole Body Vibration Level	6
Safety and Instructional Decals	7
Setup	11
1 Installing the Roll Bar	12
2 Installing the Seat	12
3 Installing the Steering Wheel	12
4 Activating and Charging the Battery	13
5 Installing the Oil Cooler (optional)	14
6 Installing the Grass-Basket Hooks	14
7 Installing the Cutting Units	15
8 Adding Rear Weight	15
9 Installing EU Decals	15
10 Reducing the Tire Pressure	15
11 Burnishing the Brakes	15
Product Overview	16
Controls	16
Specifications	19
Attachments/Accessories	19
Operation	20
Think Safety First	20
Checking the Engine Oil	20
Filling the Fuel Tank	21
Checking the Hydraulic-Fluid Level	22
Checking the Reel-to-Bedknife Contact	23
Checking the Tire Pressure	23
Checking the Torque of the Wheel Nuts	23
Breaking in the Machine	23
Starting and Stopping the Engine	23
Checking the Safety-Interlock System	24
Checking the Leak Detector	25
Installing and Removing the Cutting Units	26
Setting the Reel Speed	28
Mowing	29
Inspecting and Cleaning after Mowing	30
Driving the Machine without Mowing	30
Transporting the Machine	30
Towing the Machine	31
Maintenance	32
Recommended Maintenance Schedule(s)	32
Daily Maintenance Checklist	33
Engine Maintenance	34
Servicing the Air Cleaner	34
Changing the Engine Oil and Filter	34
Replacing the Spark Plugs	35
Fuel System Maintenance	35
Replacing the Fuel Filter	35
Inspecting the Fuel Lines and Connections	35
Electrical System Maintenance	36
Servicing the Battery	36
Locating the Fuses	36

Drive System Maintenance	37
Adjusting the Transmission for Neutral	37
Adjusting the Transport Speed	37
Adjusting the Mowing Speed	38
Brake Maintenance	38
Adjusting the Brakes	38
Hydraulic System Maintenance	39
Changing the Hydraulic Fluid and Filter	39
Checking the Hydraulic Lines and Hoses	39
Cutting Unit Maintenance	40
Backlapping the Reels	40
Diagnostics System	41
Diagnosing the Service-Indicator Light	41
Storage	41

Safety

This machine has been designed in accordance with EN ISO 5395:2013 and ANSI B71.4-2012 and meets these standards when the appropriate weight kit is added.

Improper use or maintenance by the operator or owner can result in injury. To reduce the potential for injury, comply with these safety instructions and always pay attention to the safety alert symbol (Figure 2), which means Caution, Warning, or Danger—personal safety instruction. Failure to comply with the instruction may result in personal injury or death.

Safe Operating Practices

Training

- Read the *Operator's Manual* and other training material. If the operator(s) or mechanic(s) cannot read the manual it is the owner's responsibility to explain this material to them.
- Become familiar with the safe operation of the equipment, operator controls, and safety signs.
- All operators and mechanics should be trained. The owner is responsible for training the users.
- Never let children or untrained people operate or service the equipment. Local regulations may restrict the age of the operator.
- The owner/user can prevent and is responsible for accidents or injuries occurring to people or property.

Preparation

- Evaluate the terrain to determine what accessories and attachments are needed to properly and safely perform the job. Use only accessories and attachments approved by the manufacturer.
- Wear appropriate clothing including substantial, slip-resistant footwear, safety glasses, and hearing protection. Tie back long hair. Do not wear jewelry.
- Inspect the area where you will use the equipment and remove all objects that could be thrown by the machine, such as rocks, toys, and wire.
- Check that operator presence controls, safety switches, and guards are attached and functioning properly. Do not operate the machine unless they are functioning properly.

Operation

- Do not operate the engine in a confined space where dangerous carbon monoxide and other exhaust gasses can collect.
- Operate the machine only in good light, keeping away from holes and hidden hazards.
- Be sure all drives are in neutral and the parking brake is engaged before the starting engine. Start the engine only from the operator's position.

- Slow down and use extra care on hillsides. Turf conditions can affect the machine's stability. Use caution while operating near drop-offs.
- Slow down and use caution when making turns and when changing directions on slopes.
- Never operate without guards securely in place. Be sure all interlocks are attached, adjusted, and functioning properly.
- Do not change the engine governor setting or overspeed the engine.
- Stop the machine on level ground, lower the cutting units, disengage the drives, engage the parking brake, and shut off the engine before leaving the operator's position for any reason, including emptying the grass baskets.
- Stop and inspect the machine after striking objects or if an abnormal vibration occurs. Make necessary repairs before resuming operations.
- Keep hands and feet away from the cutting units.
- Look behind and down before backing up to be sure of a clear path.
- Never carry passengers and keep pets and bystanders away.
- Slow down and use caution when making turns and crossing roads and sidewalks. Stop the reels if not mowing.
- Do not operate the machine when tired, ill, or under the influence of alcohol or drugs.
- Lightning can cause severe injury or death. If lightning is seen or thunder is heard in the area, do not operate the machine; seek shelter.
- Use care when loading or unloading the machine into a trailer or truck.
- Use care when approaching blind corners, shrubs, trees, or other objects that may obscure vision.

Rollover Protection System (ROPS)—Use and Maintenance

- The ROPS is an integral and effective safety device. Use the seat belt when operating the machine.
- Ensure that you can release the seat belt quickly in the event of an emergency.
- Check carefully for overhead clearances (i.e. branches, doorways, electrical wires) before driving under any objects and do not contact them.
- Keep the ROPS in safe operating condition by periodically thoroughly inspecting for damage and keeping all mounting fasteners tight.
- Replace a damaged ROPS. Do not repair or revise.
- Do not remove the ROPS.
- Any alterations to a ROPS must be approved by the manufacturer.

Maintenance and Storage

- Park the machine on level ground, disengage the drives, lower the cutting units, set the parking brake, stop the engine, remove the key, and disconnect spark plug wire(s). Wait for all movement to stop before adjusting, cleaning, or repairing the machine.
- Clean grass and debris from cutting units, drives, mufflers, and the engine to help prevent fires. Clean up oil or fuel spills.
- Let the engine cool before storing and do not store the machine near flames.
- Shut off the fuel while storing or transporting the machine. Do not store fuel near flames or drain the fuel tank indoors.
- Never allow untrained personnel to service the machine.
- Use jack stands to support components when required.
- Carefully release pressure from components with stored energy.
- Disconnect the battery and remove the spark plug wire(s) before making any repairs. Disconnect the negative terminal first and the positive last. Connect the positive terminal first and the negative terminal last.
- Use care and wear gloves when checking the reels.
- Keep hands and feet away from moving parts. If possible, do not make adjustments with the engine running.
- Charge batteries in an open, well-ventilated area, away from spark and flames. Unplug the charger before connecting or disconnecting it from the battery. Wear protective clothing and use insulated tools.
- Keep all parts in good working condition and all hardware and hydraulic fittings tightened. Replace all worn or damaged decals.
- Do not drive close to sand traps, ditches, creeks, or other hazards.
- Reduce speed when making sharp turns. Avoid sudden stops and starts.
- This machine is not designed or equipped for on-road use and is a “slow-moving vehicle.” If you must cross or travel on a public road, you should be aware of and comply with local regulations, such as required lights, slow-moving vehicle signs, and reflectors.
- Watch out for traffic when near or crossing roads. Always yield the right-of-way.
- Apply the service brakes when going downhill to keep forward speed slow and to maintain control of the machine.
- The grass baskets must be in place during operation of the reels or thatchers for maximum safety. Shut the engine off before emptying the baskets.
- Raise the cutting units when driving from one work area to another.
- Do not touch the engine, muffler, or exhaust pipe while the engine is running or soon after it has stopped because these areas could be hot enough to cause burns.
- Stay clear of the rotating screen at the side of the engine to prevent direct contact with your body or clothing.
- If a cutting unit strikes a solid object or vibrates abnormally, stop immediately, turn the engine off, wait for all motion to stop, and inspect the machine for damage. Repair or replace a damaged reel or bedknife before continuing operation.
- Before getting off the seat, move the functional control lever to NEUTRAL, raise the cutting units, and wait for the reels to stop spinning. Set the parking brake. Stop the engine and remove the key from the ignition switch.
- Traverse slopes carefully. Do not start or stop suddenly when traveling uphill or downhill.
- The operator must be skilled and trained in how to drive on hillsides. Failure to use caution on slopes or hills may cause loss of control and cause the machine to tip or roll, possibly resulting in personal injury or death.
- If the engine stalls or loses headway and cannot make it to the top of a slope, do not turn the machine around. Always back slowly, straight down the slope.
- When a person or animal appears unexpectedly in or near the mowing area, **stop mowing**. Careless operation, combined with terrain angles, ricochets, or improperly positioned guards can lead to thrown-object injuries. Do not resume mowing until the area is cleared.

Toro Mower Safety

The following list contains safety information specific to Toro products or other safety information that you must know that is not included in the ANSI standards.

This product is capable of amputating hands and feet and of throwing objects. Always follow all safety instructions to avoid serious injury or death.

Use of this product for purposes other than its intended use could prove dangerous to user and bystanders.

Operation

- Know how to stop the engine quickly.
- Check the safety interlock switches daily for proper operation.
- Before attempting to start the engine, disengage all blade attachment clutches, shift into neutral, and engage the parking brake.
- Using the machine demands attention. To prevent loss of control:

Maintenance and Storage

- Ensure that all hydraulic line connectors are tight and that all hydraulic hoses and lines are in good condition before applying pressure to the system.
- Keep your body and hands away from pin-hole leaks or nozzles that eject hydraulic fluid under high pressure.

Use paper or cardboard, not your hands, to search for leaks. Hydraulic fluid escaping under pressure can have sufficient force to penetrate the skin and cause serious injury.

- Before disconnecting or performing any work on the hydraulic system, all pressure in the system must be relieved by stopping the engine and lowering the cutting units and attachments to the ground.
- Check all fuel lines for tightness and wear on a regular basis. Tighten or repair them as needed.
- If the engine must be running to perform a maintenance adjustment, keep hands, feet, clothing, and any parts of the body away from the cutting units, attachments, and any moving parts, especially the screen at the side of the engine. Keep everyone away.
- Do not overspeed the engine by changing governor settings. To ensure safety and accuracy, have an Authorized Toro Distributor check the maximum engine speed with a tachometer..
- The engine must be shut off before checking the oil or adding oil to the crankcase.
- If major repairs are ever needed or if assistance is desired, contact an Authorized Toro Distributor.
- To ensure optimum performance and continued safety certification of the machine, use only genuine Toro replacement parts and accessories. Replacement parts and accessories made by other manufacturers could be dangerous, and such use could void the product warranty.

Whole Body Vibration Level

Measured vibration level = 0.35 m/s^2

Uncertainty Value (K) = 0.17 m/s^2

Measured values were determined according to the procedures outlined in EN ISO 5395:2013.

Sound Power Level

This unit has a guaranteed sound power level of 94 dBA, which includes an Uncertainty Value (K) of 1 dBA.

Sound power level was determined according to the procedures outlined in ISO 11094.

Sound Pressure Level

This unit has a sound pressure level at the operator's ear of 80 dBA, which includes an Uncertainty Value (K) of 1 dBA.

Sound pressure level was determined according to the procedures outlined in EN ISO 5395:2013.

Hand-Arm Vibration Level

Measured vibration level for right hand = 0.22 m/s^2

Measured vibration level for left hand = 0.24 m/s^2

Uncertainty Value (K) = 0.12 m/s^2

Measured values were determined according to the procedures outlined in EN ISO 5395:2013.

Safety and Instructional Decals



Safety decals and instructions are easily visible to the operator and are located near any area of potential danger. Replace any decal that is damaged or lost.

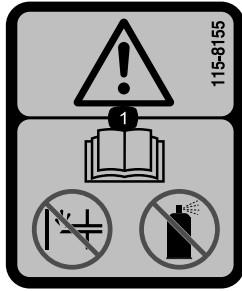

115-8155

1. Warning—read the *Operator's Manual*, do not prime or use starting fluid.

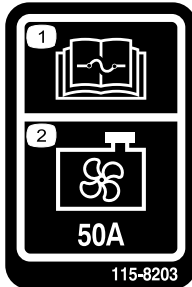

115-8203

1. Read the *Operator's manual* for fuse information.
2. Radiator fan—50 Amp

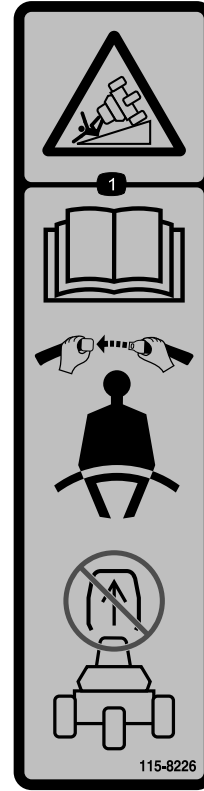

115-8226

1. Tipping hazard—read the *Operator's manual*; always wear a seat belt when operating; do not remove the rollover protection system (ROPS).

CALIFORNIA SPARK ARRESTER WARNING

Operation of this equipment may create sparks that can start fires around dry vegetation. A spark arrester may be required. The operator should contact local fire agencies for laws or regulations relating to fire prevention requirements. 117-2718

117-2718

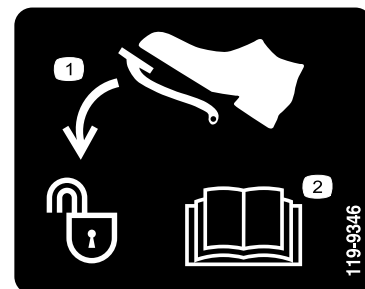

119-9346

1. Press pedal to unlock
2. Read the *Operator's Manual* for more information.

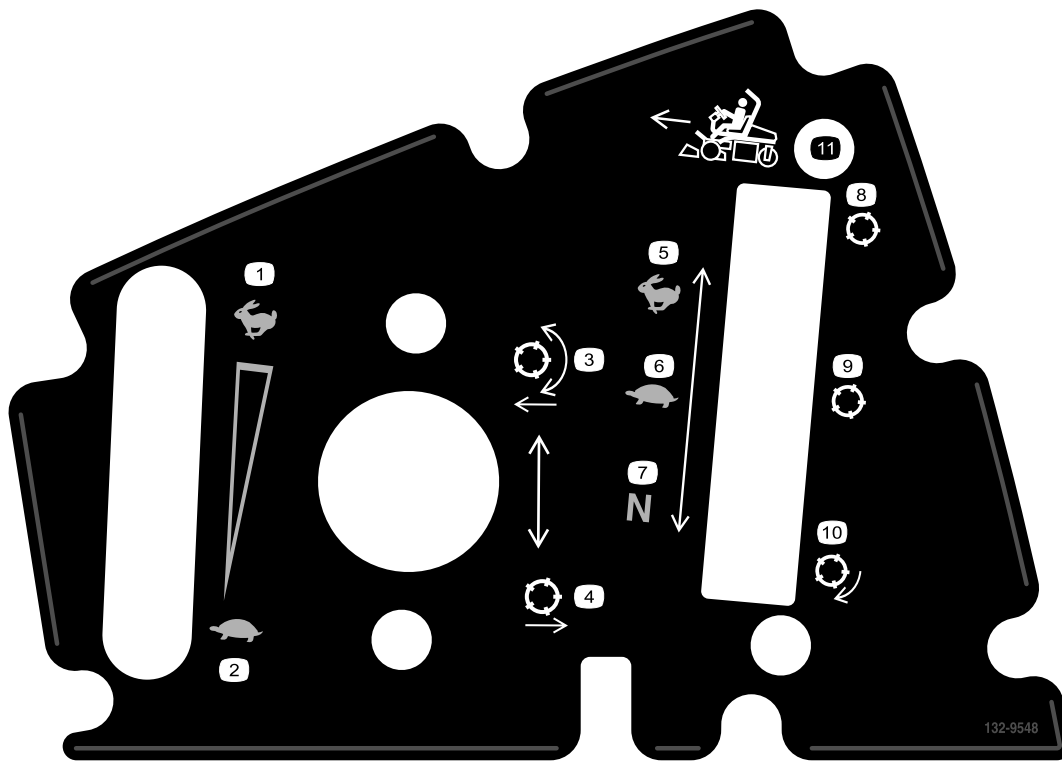

132-9548

- | | |
|----------------------------------|-----------------------|
| 1. Engine speed—fast | 7. Reel speed—neutral |
| 2. Engine speed—slow | 8. Reel—transport |
| 3. Lower and engage the reels | 9. Reel—mow |
| 4. Raise and disengage the reels | 10. Reel—backlapping |
| 5. Reel speed—fast | 11. Move forward |
| 6. Reel speed—slow | |

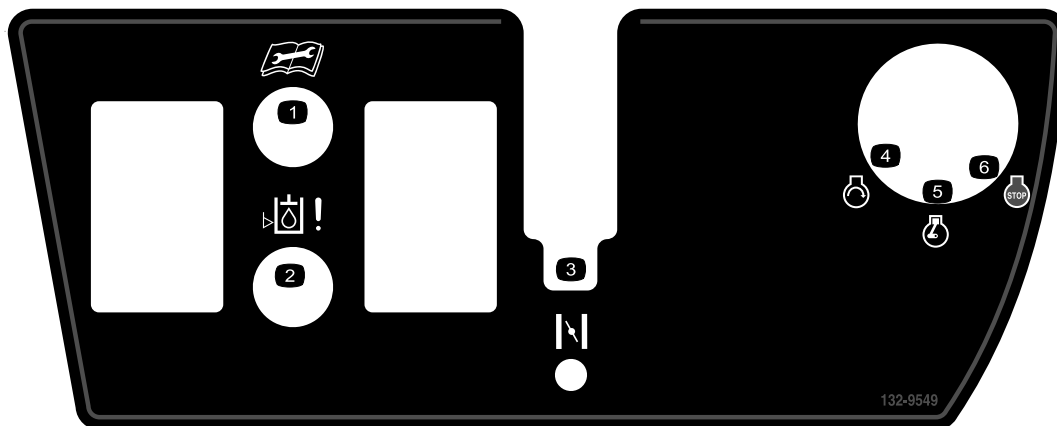

132-9549

- | | |
|--|-----------------|
| 1. Read the <i>Operator's Manual</i> before servicing or performing maintenance. | 4. Engine—start |
| 2. Hydraulic fluid level | 5. Engine—run |
| 3. Choke | 6. Engine—stop |



Battery Symbols

Some or all of these symbols are on your battery

- | | |
|--|--|
| 1. Explosion hazard | 6. Keep bystanders a safe distance from the battery. |
| 2. No fire, open flame, or smoking. | 7. Wear eye protection; explosive gases can cause blindness and other injuries |
| 3. Caustic liquid/chemical burn hazard | 8. Battery acid can cause blindness or severe burns. |
| 4. Wear eye protection | 9. Flush eyes immediately with water and get medical help fast. |
| 5. Read the <i>Operator's Manual</i> . | 10. Contains lead; do not discard. |

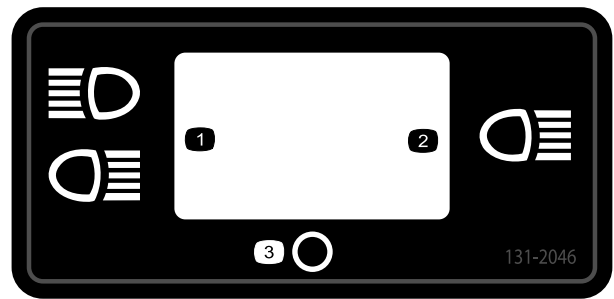

131-2046

- | | |
|------------------|--------|
| 1. Double lights | 3. Off |
| 2. Single light | |

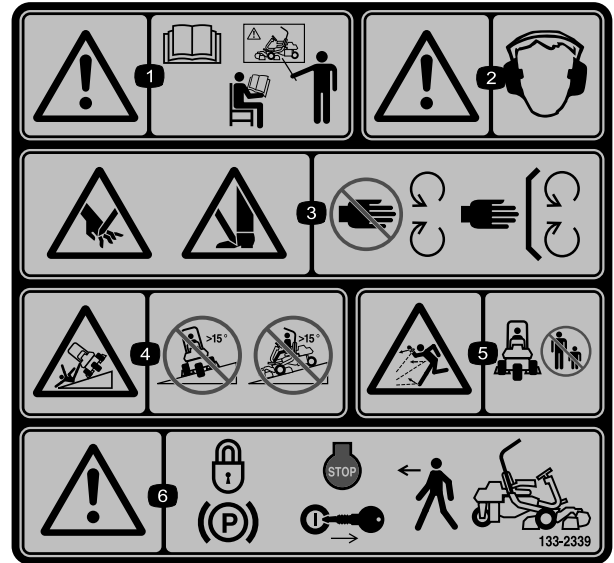

133-2339

Replaces Decal 133-2338 for CE Machines

- | | |
|---|--|
| 1. Warning—read the <i>Operator's Manual</i> , do not operate this machine unless you are trained. | 4. Tipping hazard—do not drive across or down slopes greater than 15 degrees. |
| 2. Warning—wear hearing protection. | 5. Thrown object hazard—keep bystanders a safe distance from the machine. |
| 3. Cutting/dismemberment hazard of hand or foot, mower blade—stay away from moving parts; keep all guards and shields in place. | 6. Warning—lock the parking brake, stop the engine and remove the ignition key before leaving the machine. |

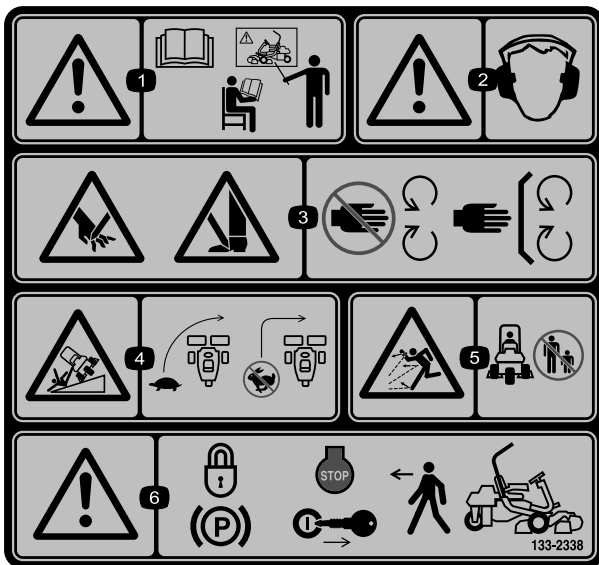

133-2338

- | | |
|---|--|
| 1. Warning—read the <i>Operator's Manual</i> , do not operate this machine unless you are trained. | 4. Tipping hazard—slow machine before turning, do not turn at high speeds. |
| 2. Warning—wear hearing protection. | 5. Thrown object hazard—keep bystanders a safe distance from the machine. |
| 3. Cutting/dismemberment hazard of hand or foot, mower blade—stay away from moving parts; keep all guards and shields in place. | 6. Warning—lock the parking brake, stop the engine and remove the ignition key before leaving the machine. |

GREENSMASTER 3XXX

1	2		3		4		5	6
	3.8 MPH 6.1 Km/h	5.0 MPH 8.0 Km/h	3.8 MPH 6.1 Km/h	5.0 MPH 8.0 Km/h	3.8 MPH 6.1 Km/h	5.0 MPH 8.0 Km/h	3.8 MPH 6.1 Km/h	
0.062" / 1.6mm	N/R	N/R	9	N/R	9	N/R	9	
0.094" / 2.4mm	N/R	N/R	9	N/R	9	N/R	9	
0.125" / 3.2mm	N/R	N/R	9	N/R	9	N/R	9	
0.156" / 4.0mm	N/R	N/R	9	N/R	9	N/R	N/R	
0.188" / 4.8mm	N/R	N/R	9	N/R	7	N/R	N/R	
0.218" / 5.5mm	N/R	N/R	9	N/R	6	N/R	N/R	
0.250" / 6.4mm	7	N/R	6	7	5	7	N/R	
0.312" / 7.9mm	6	N/R	5	6	4	6	N/R	
0.375" / 9.5mm	6	7	4	5	4	5	N/R	
0.438" / 11.1mm	6	6	4	5	3	4	N/R	
0.500" / 12.7mm	5	6	3	4	N/R	N/R	N/R	
0.625" / 15.9mm	4	5	3	3	N/R	N/R	N/R	
0.750" / 19.0mm	3	4	3	3	N/R	N/R	N/R	
0.875" / 22.2mm	3	4	N/R	3	N/R	N/R	N/R	
1.000" / 25.4mm	3	3	N/R	N/R	N/R	N/R	N/R	

115-8156

115-8156

- | | | | |
|-------------------------|--------------------------|--------------------------|---------|
| 1. Reel height | 3. 8-Blade cutting unit | 5. 14-Blade cutting unit | 7. Fast |
| 2. 5-Blade cutting unit | 4. 11-Blade cutting unit | 6. Reel speed | 8. Slow |

GREENSMASTER 3300/3320 TriFlex

QUICK REFERENCE AID

CHECK/SERVICE (daily)

1. OIL LEVEL, ENGINE	5. LEAK DETECTOR ALARM
2. OIL LEVEL, HYDRAULIC TANK	6. AIR FILTER / PRECLEANER
3. BRAKE FUNCTION	7. ENGINE COOLING FINS
4. INTERLOCK SYSTEM:	8. TIRE PRESSURE (12 - 16 psi)
4a. SEAT INTERLOCK	9. BATTERY
4b. NEUTRAL SENSOR	10. WHEEL NUT TORQUE (70-90 FT LBS)
4c. MOW SENSOR	11. FUEL - GAS
4d. PARKING BRAKE INTERLOCK	12. REEL SPEED / BACKLAP CONTROL

FLUID SPECIFICATIONS / CHANGE INTERVALS

See operator's manual for initial change	FLUID TYPE	CAPACITY		CHANGE INTERVALS		FILTER PART NO.
		L	QTS.	FLUID	FILTER	
A. ENGINE OIL	SAE 10W-30 SJ	1.6*	1.75*	100 HRS.	100 HRS.	107-7817
B. AIR CLEANER	_____	_____	_____	_____	100 HRS.	692519
C. FUEL FILTER	_____	_____	_____	_____	1000 HRS.	94-2690
D. HYDRAULIC OIL (3300)	ISO VG 46	22.7*	24*	800 HRS.	800 HRS.	108-5194
D. HYDRAULIC OIL (3320)	ISO VG 46	18.9*	20*	800 HRS.	800 HRS.	108-5194
E. FUEL TANK	UNLEADED GAS	22.7	6 GAL.	_____	_____	_____

*Including filter

119-9345

Setup

Loose Parts

Use the chart below to verify that all parts have been shipped.

Procedure	Description	Qty.	Use
1	Roll bar	1	Install the roll bar.
	Bolt (1/2 x 3-3/4 inches)	4	
	Flange-nut (1/2 inch)	4	
2	Seat	1	Install the seat to the base.
	Seat wiring harness	1	
3	Steering wheel	1	Install the steering wheel.
	Locknut (1-1/2 inches)	1	
	Washer	1	
	Steering-wheel cap	1	
4	No parts required	–	Activate and charge the battery.
5	No parts required	–	Install the optional oil cooler.
6	Grass-basket hook	6	Install the grass-basket hooks.
	Flange bolts	12	
7	Gauge bar	1	Install the cutting units.
	Cutting unit (obtain from your Toro Distributor)	3	
	Grass basket	3	
8	Weight kit, 119-7129 (purchase separately)	1	Add rear weight.
9	Warning decal, 133-2338	1	Install EU decals, if required.
10	No parts required	–	Reduce the tire pressure.
11	No parts required	–	Burnish the brakes.

Media and Additional Parts

Description	Qty.	Use
Operator's Manual (traction unit)	1	Read before operating the machine
Engine Operator's Manual (engine)	1	
Parts Catalog	1	Save for future parts ordering
Operator Training Materials	1	View before operating the machine
Pre-delivery Inspection Sheet	1	Save for future reference
Noise rating certificate	1	
Certificate of compliance	1	
Ignition keys	2	Start the engine

1

Installing the Roll Bar

Parts needed for this procedure:

1	Roll bar
4	Bolt (1/2 x 3-3/4 inches)
4	Flange-nut (1/2 inch)

Procedure

1. Remove the top crate support from the crate.
2. Remove the roll bar from the crate.
3. Install the roll bar into the pockets on each side of the machine, using 4 bolts (1/2 x 3-3/4 inches) and 4 flange-nuts (1/2 inch) (Figure 3).

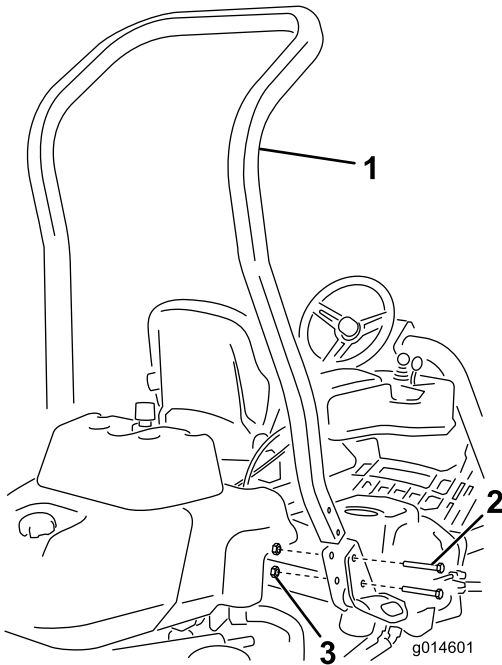

Figure 3

1. Roll bar
2. Bolt (1/2 x 3-3/4 inches)
3. Flange-nut (1/2 inch)

4. Torque the fasteners to 136 to 149 N·m (100 to 110 ft-lb).

2

Installing the Seat

Parts needed for this procedure:

1	Seat
1	Seat wiring harness

Procedure

Note: Mount the seat in the front set of mounting holes to gain an additional 7.6 cm (3 inches) in the forward adjustment, or in the rear mounting holes for an additional 7.6 cm (3 inches) in the rearward adjustment.

1. Remove and discard the lag bolts securing the seat slides and cut the shipping straps.
2. Remove the 4 bolts (5/16 x 3/4 inch) and washers from the shipping bracket and discard the bracket.
3. Secure the seat to the seat base with 4 bolts and washers removed previously (Figure 4).

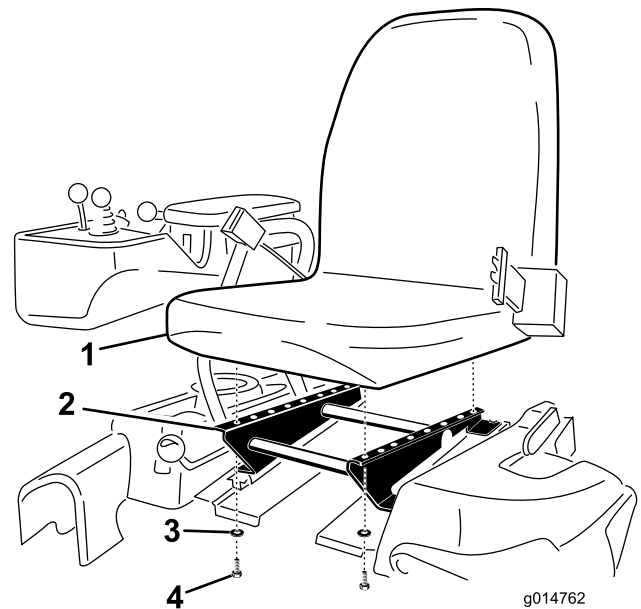

Figure 4

1. Seat
2. Seat base
3. Washer
4. Bolt (5/16 x 3/4 inch)

4. Locate the open connector on the main wiring harness to the right of the seat and connect it to the wiring harness that came with the seat.
5. Route the seat wiring harness around the seat slides, ensuring that it will not be pinched when the seat moves, and connect it to the port on the bottom of the seat.

3

Installing the Steering Wheel

Parts needed for this procedure:

1	Steering wheel
1	Locknut (1-1/2 inches)
1	Washer
1	Steering-wheel cap

Procedure

- Slide the steering wheel onto the steering shaft (Figure 5).

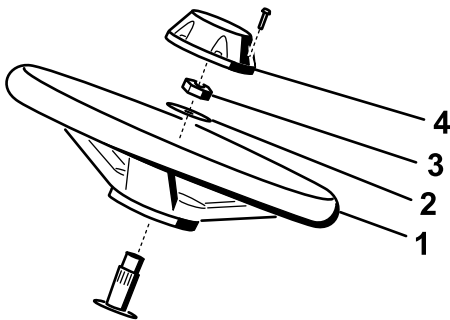

g014687

Figure 5

- | | |
|-------------------|------------|
| 1. Steering wheel | 3. Locknut |
| 2. Washer | 4. Cap |

- Slide the washer onto the steering shaft (Figure 5).
- Secure the steering wheel to the shaft with a locknut and tighten it to 27 to 35 N·m (20 to 26 ft-lb) (Figure 5).
- Install the cap to the steering wheel and secure it with 6 bolts (Figure 5).

4

Activating and Charging the Battery

No Parts Required

Procedure

Use only electrolyte (1.265 specific gravity) to fill the battery initially.

⚠ WARNING

CALIFORNIA Proposition 65 Warning

Battery posts, terminals, and related accessories contain lead and lead compounds, chemicals known to the State of California to cause cancer and reproductive harm.
Wash hands after handling.

- Remove the fasteners and battery clamp and lift out the battery.

Important: Do not add electrolyte while the battery is in the machine. You could spill it, causing corrosion.

- Clean the top of the battery and remove the vent caps (Figure 6).

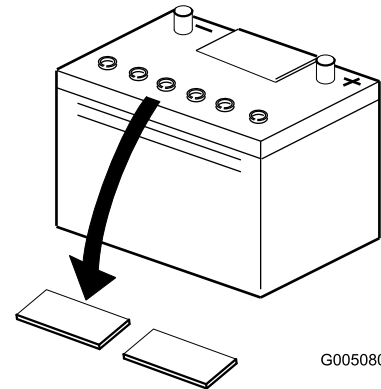

Figure 6

- Carefully fill each cell with electrolyte until the plates are covered with about 6 mm (1/4 inch) of fluid (Figure 7).

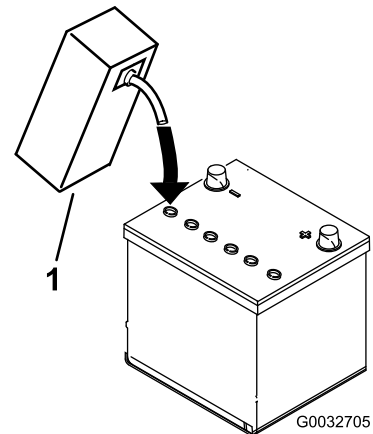

Figure 7

- Electrolyte

- Allow approximately 20 to 30 minutes for the electrolyte to soak into the plates. Fill as necessary to

bring the electrolyte to within about 6 mm (1/4 inch) of the bottom of the fill well (Figure 7).

5. Connect a 2 to 4 A battery charger to the battery posts. Charge the battery for at least 2 hours at 4 A or for at least 4 hours at 2 A until the specific gravity is 1.250 or higher and the temperature is at least 16°C (60°F) with all cells gassing freely.

⚠ WARNING

Charging the battery produces gasses that can explode.

Never smoke near the battery and keep sparks and flames away from the battery.

Important: If you do not charge the battery for at least the time specified above, you may reduce the life of the battery.

6. When the battery is charged, disconnect the charger from the electrical outlet and battery posts.

Note: After the battery has been activated, add only distilled water to replace normal loss, although maintenance-free batteries should not require water under normal operating conditions.

⚠ WARNING

Battery terminals or metal tools could short against metal tractor components causing sparks. Sparks can cause the battery gasses to explode, resulting in personal injury.

- When removing or installing the battery, do not allow the battery terminals to touch any metal parts of the tractor.
- Do not allow metal tools to short between the battery terminals and metal parts of the tractor.

Important: Failure to correctly activate the battery may result in battery gassing and/or premature battery failure.

7. Install the vent caps.
8. Place the battery on the battery tray and secure it with the battery clamp and fasteners removed previously.
9. Install the positive cable (red) to the positive (+) terminal and then the negative cable (black) to the negative (-) terminal of the battery and secure them with the bolts and nuts (Figure 8). Slide the rubber boot over the positive terminal to prevent a possible short from occurring.

⚠ WARNING

Incorrect battery cable routing could damage the tractor and cables causing sparks. Sparks can cause the battery gasses to explode, resulting in personal injury.

- Always disconnect the negative (black) battery cable before disconnecting the positive (red) cable.
- Always connect the positive (red) battery cable before connecting the negative (black) cable.

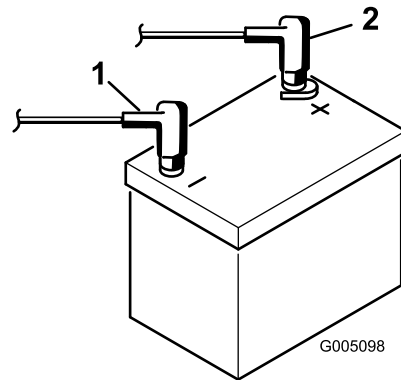

Figure 8

1. Negative (-)
2. Positive (+)

5

Installing the Oil Cooler (optional)

No Parts Required

Procedure

If you are operating the machine in hot climates, where the ambient temperature is above 29°C (85°F), or using it for heavy-duty use (mowing other than greens, such as fairways or verticutting), install a Hydraulic Oil Cooler Kit, Part No. 119-1691.

6

Installing the Grass-Basket Hooks

Parts needed for this procedure:

6	Grass-basket hook
12	Flange bolts

Procedure

Install the 6 grass-basket hooks onto the ends of the suspension-arm bars using the 12 flange bolts ([Figure 9](#)).

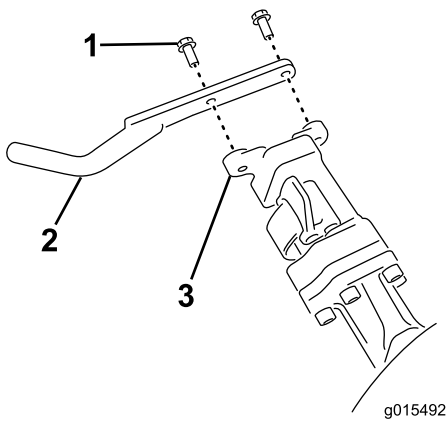

Figure 9

- 1. Flange bolt
- 2. Grass-basket hook
- 3. Suspension-arm bar

7

Installing the Cutting Units

Parts needed for this procedure:

1	Gauge bar
3	Cutting unit (obtain from your Toro Distributor)
3	Grass basket

Procedure

1. Setup the cutting units as described in the cutting unit *Operator's Manual*.
2. Apply grease to the inside diameter of the drive coupler.
3. Install the cutting units as described in [Installing the Cutting Units](#) (page 26).

8

Adding Rear Weight

Parts needed for this procedure:

1	Weight kit, 119-7129 (purchase separately)
---	--

Procedure

This unit complies with the ANSI B71.4-2012 and EN ISO 5395:2013 Standards when equipped with the Weight Kit, Part No. 119-7129.

9

Installing EU Decals

Parts needed for this procedure:

1	Warning decal, 133-2338
---	-------------------------

Procedure

If this machine will be used in the EU, affix the warning-decal 133-2338 over English warning-decal 133-2339.

10

Reducing the Tire Pressure

No Parts Required

Procedure

The tires are over-inflated at the factory for shipping purposes. Reduce the pressure to the proper levels before starting the machine. Refer to [Checking the Tire Pressure](#) (page 23).

11

Burnishing the Brakes

No Parts Required

Procedure

Firmly apply the brakes and drive the machine at mowing speed until the brakes are hot, as indicated by their smell. You may need to adjust the brakes after the break-in period; refer to [Adjusting the Brakes \(page 38\)](#).

Product Overview

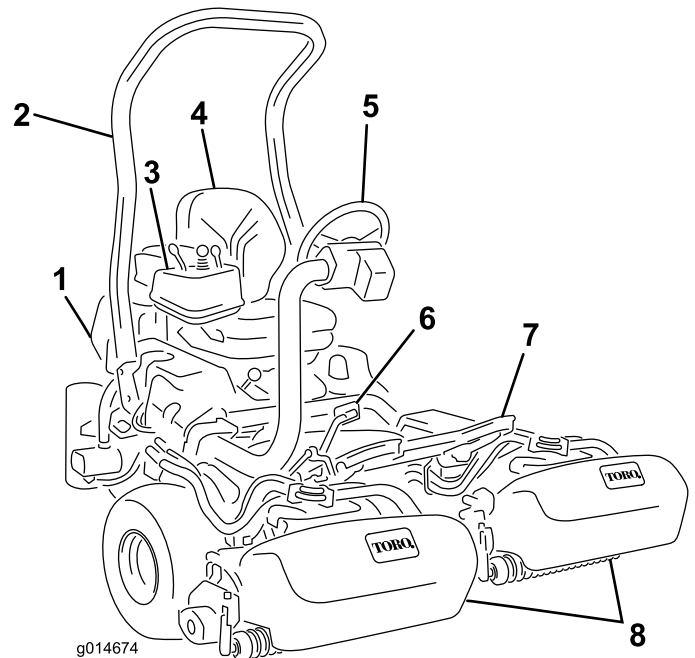

Figure 10

- | | |
|------------------|-------------------|
| 1. Engine | 5. Steering wheel |
| 2. Roll bar | 6. Traction pedal |
| 3. Control panel | 7. Footrest |
| 4. Seat | 8. Cutting units |

Controls

Traction Pedal

The traction pedal ([Figure 11](#)) has 3 functions: to make the machine move forward, to move it backward, and to stop the machine. Press the top of the pedal to move forward and the bottom of the pedal to move backward or to assist in stopping when moving forward. Also, allow the pedal to move to the neutral position to stop the machine. For operator comfort, do not rest the heel of your foot on reverse when operating forward ([Figure 12](#)).

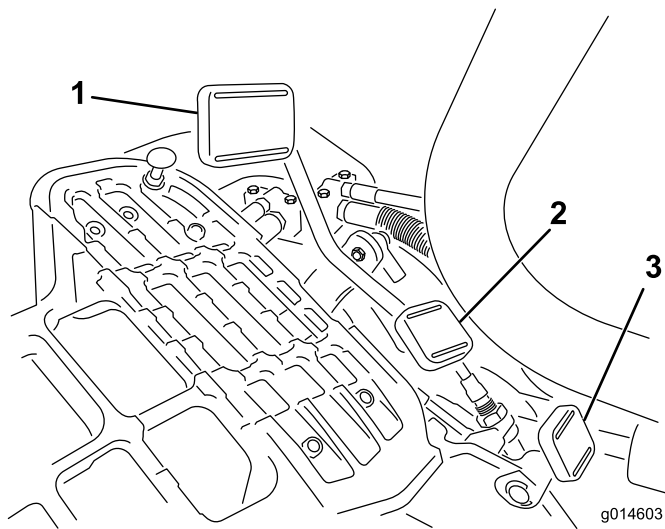

Figure 11

- | | |
|---------------------------|-------------------------------|
| 1. Traction pedal—forward | 3. Steering arm locking pedal |
| 2. Traction pedal—reverse | |

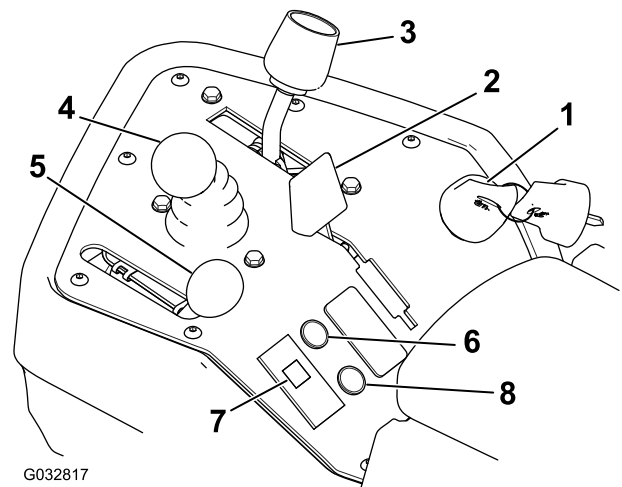

Figure 13

- | | |
|-----------------------------|------------------------------|
| 1. Ignition switch | 5. Throttle lever |
| 2. Choke lever | 6. Service-indicator light |
| 3. Functional-control lever | 7. Engine-oil-pressure light |
| 4. Raise/lower mow control | 8. Leak-indicator light |



Figure 12

Ground speeds are as follows:

- 3.2 to 8 km/h (2 to 5 mph) forward mowing speed
- 16 km/h (10 mph) maximum transport speed
- 4.0 km/h (2.5 mph) reverse speed

Steering-Arm-Locking Pedal

Press the pedal (Figure 11) and raise or lower the steering arm for operator comfort, then, release the pedal to lock the arm in place.

Throttle Lever

The throttle lever (Figure 13) allows you to control the speed of the engine. Move the throttle lever toward the FAST position to increase the engine speed; move it toward the SLOW position to decrease the engine speed.

Note: You cannot stop the engine cannot using the throttle lever.

Choke Lever

To start a cold engine, close the carburetor choke by pulling the choke lever rearward (Figure 13) to the CLOSED position. After the engine starts, regulate the choke lever to keep the engine running smoothly. As soon as possible, open the choke by pushing the lever forward to the OPEN position. A warm engine requires little or no choking.

Raise/Lower Mow Control

Moving the control (Figure 13) forward during operation lowers the cutting units and starts the reels. Pull back on the control to stop the reels and raise the cutting units. During operation the reels can be stopped by pulling back on the control momentarily and releasing it. Start the reels by moving the control forward.

Functional Control Lever

The functional control lever (Figure 13) provides 2 traction selections plus a NEUTRAL position. It is permissible to shift from mow to transport or transport to mow (not to neutral) while the machine is in motion. No damage will result.

- REAR Position—neutral and backlapping
- MIDDLE Position—used for mowing operation
- FRONT Position—used for transport operation

Ignition Switch

Insert the key into the switch (Figure 13) and turn it clockwise as far as possible to the START position to start the engine. Release the key as soon as the engine starts; the key will move to the ON position. Turn the key counterclockwise to the OFF position to stop the engine.

Engine-Oil-Pressure Light

The light (Figure 13) glows if the engine-oil pressure drops below a safe level.

Service-Indicator Light

The service-indicator light (Figure 13) illuminates when the machine sensors detect an issue with 1 of the systems of the machine. If this light illuminates, stop what you are doing and drive to a safe location where you or a service technician can diagnose the problem. For more information on diagnosing system issues using the service indicator light, refer to [Diagnosing the Service-Indicator Light](#) (page 41).

Leak-Indicator Light

This light illuminates and an alarm sounds if the hydraulic fluid level drops in the hydraulic reservoir; refer to [Operating the Leak Detector](#) (page 26) and [Checking the Hydraulic-Fluid Level](#) (page 22).

Hour Meter

The hour meter (Figure 14) indicates the total hours the machine has operated. It starts to function whenever you rotate the ignition switch to the ON position.

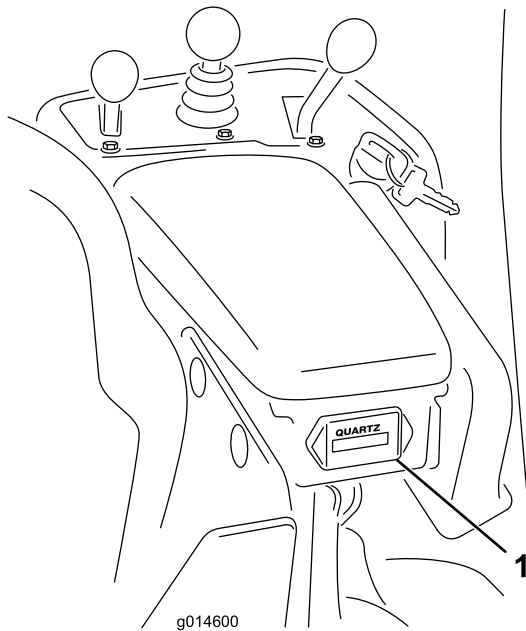

Figure 14

1. Hour meter

Parking-Brake Lever

Pull up on the brake lever (Figure 15) to set the parking brake. Disengage it by squeezing the release lever on the underside of the brake lever and lowering it down to its released position. Lock the parking brake any time you leave the machine.

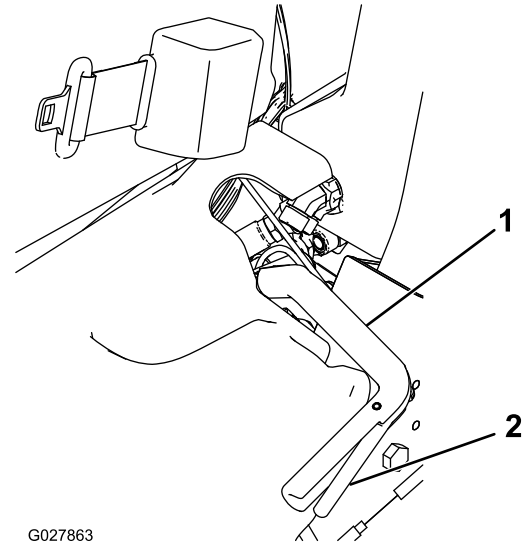

Figure 15

Backlap Lever

The backlap lever is located under the plastic cover to the left of the seat. Use the backlap lever (Figure 16) in conjunction with the raise/lower mower control lever and the reel-speed control for backlapping the reels.

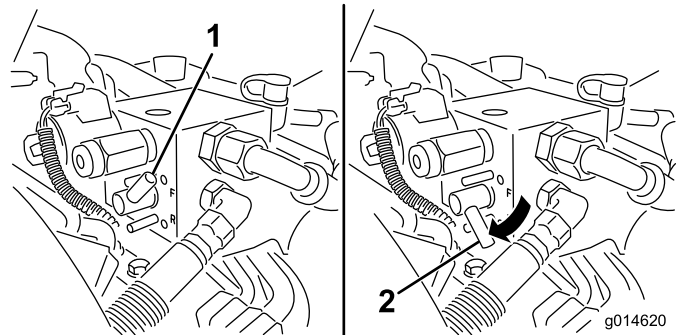

Figure 16

1. Backlap lever—mow position
2. Backlap lever—backlap position

Reel-Speed Control

The reel-speed control is located under the plastic cover to the left of the seat. Use the reel-speed control (Figure 17) to adjust the speed of the reels.

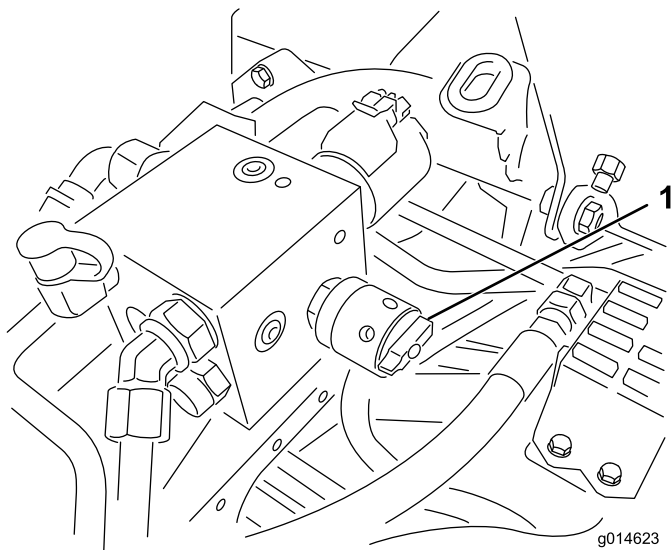

Figure 17

1. Reel-speed control

Seat-Adjusting Lever

The seat-adjusting lever is located on the front, right corner of the seat (Figure 18), allowing you to adjust the seat forward and rearward.

Note: If you need additional adjustment on the seat, you can remove the 4 bolts securing the seat to the base and move the seat to the second set of mounting holes provided.

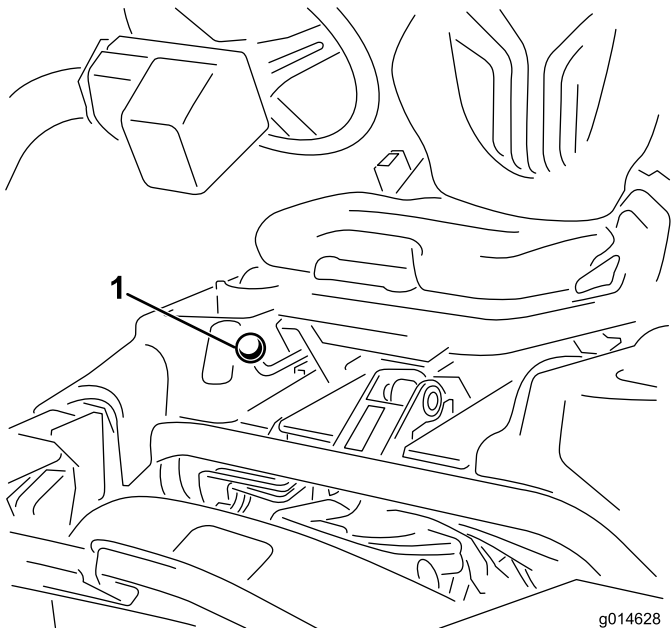

Figure 18

1. Seat-adjusting handle

Fuel-Shutoff Valve

Close the fuel-shutoff valve (Figure 19), behind the seat and under the fuel tank, when storing or transporting the machine on a truck or trailer.

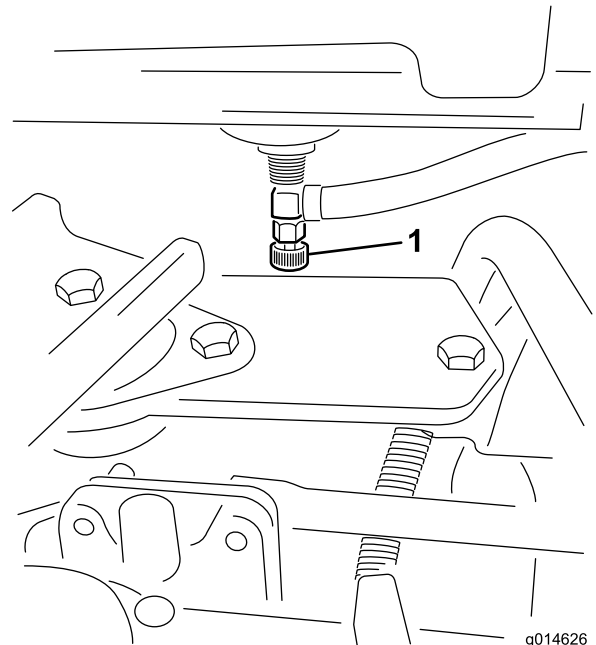

Figure 19

1. Fuel shutoff (under the fuel tank)

Specifications

Note: Specifications and design are subject to change without notice.

Width of cut	151 cm (59.5 inches)
Wheel tread	128 cm (50.5 inches)
Wheel base	119 cm (46.9 inches)
Overall length (w/baskets)	249 cm (98.0 inches)
Overall width	179 cm (70.6 inches)
Overall height	205 cm (80.8 inches)
Net Weight w/reels (8 Blade)	633 kg (1,395 lb)

Attachments/Accessories

A selection of Toro approved attachments and accessories is available for use with the machine to enhance and expand its capabilities. Contact your Authorized Service Dealer or Distributor or go to www.Toro.com for a list of all approved attachments and accessories.

To best protect your investment and maintain optimal performance of your Toro equipment, count on Toro genuine parts. When it comes to reliability, Toro delivers replacement

parts designed to the exact engineering specification of our equipment. For peace of mind, insist on Toro genuine parts.

Operation

Note: Determine the left and right sides of the machine from the normal operating position.

Think Safety First

Carefully read all safety instructions and symbols in the safety section. Knowing this information could help you or bystanders avoid injury.

⚠ DANGER

Operating the machine on wet grass or steep slopes can cause sliding and loss of control.

- Reduce speed and use extreme caution on slopes.
- Do not operate the machine near water.

⚠ DANGER

Wheels dropping over edges can cause rollovers, which may result in serious injury, death, or drowning.

Do not operate the machine near drop-offs.

⚠ CAUTION

This machine produces sound levels that can cause hearing loss through extended periods of exposure.

Wear hearing protection when operating this machine.

Use protective equipment for eyes, ears, hands, feet, and head.

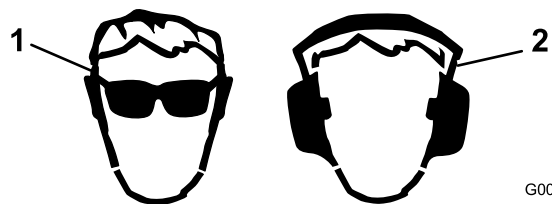

G009027

Figure 20

1. Wear eye protection.
2. Wear hearing protection.

Checking the Engine Oil

The engine is shipped with 1.65 L (1-3/4 US qt) (w/filter) of oil in the crankcase; however, you must check the oil level before and after starting the engine the first time.

The engine uses any high-quality detergent oil having the American Petroleum Institute (API) service classification of SG, SH, or SJ or higher. The recommended viscosity (weight) is SAE 30.

1. Position the machine on a level surface.
2. Unscrew the dipstick and wipe it with a clean rag.
3. Screw the dipstick into the tube and make sure it is seated fully (Figure 21).

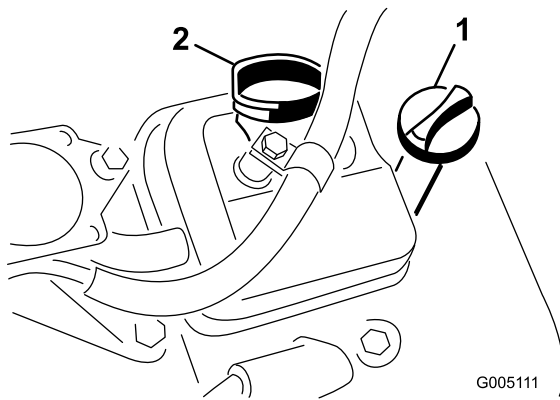

Figure 21

1. Dipstick
2. Filler cap

4. Unscrew the dipstick out of the tube and check the oil level.
5. If the oil level is low, remove the filler cap from the valve cover and pour oil into the opening in the valve cover until the oil level is up to the FULL mark on the dipstick. Add the oil slowly and check the level often during this process. **Do not overfill.**

Important: Check the oil level every 8 operating hours or daily.

6. Install the filler cap and dipstick firmly in place.

Filling the Fuel Tank

- **Fuel tank capacity:** 26.6 L (7 US gallons)
- **Recommended Fuel:**
 - For best results, use only clean, fresh (less than 30 days old), unleaded gasoline with an octane rating of 87 or higher ((R+M)/2 rating method).
 - **Ethanol:** Gasoline with up to 10% ethanol (gasohol) or 15% MTBE (methyl tertiary butyl ether) by volume is acceptable. Ethanol and MTBE are not the same. Gasoline with 15% ethanol (E15) by volume is not approved for use. **Never use gasoline that contains more than 10% ethanol by volume,** such as E15 (contains 15% ethanol), E20 (contains 20% ethanol), or E85 (contains up to 85% ethanol). Using unapproved gasoline may cause performance problems and/or engine damage, which may not be covered under the warranty.
 - **Do not** use gasoline containing methanol.
 - **Do not** store fuel either in the fuel tank or fuel containers over the winter unless you use a fuel stabilizer.
 - **Do not** add oil to gasoline.

Important: Do not use fuel additives other than a fuel stabilizer/conditioner. Do not use fuel stabilizers with an alcohol base such as ethanol, methanol, or isopropanol.

⚠ DANGER

In certain conditions, fuel is extremely flammable and highly explosive. A fire or explosion from fuel can burn you and others and can damage property.

- Fill the fuel tank outdoors, in an open area, when the engine is cold. Wipe up any fuel that spills.
- Never fill the fuel tank inside an enclosed trailer.
- Do not fill the fuel tank completely full. Add fuel to the fuel tank until the level is 1 inch (25 mm) below the bottom of the filler neck. This empty space in the tank allows fuel to expand.
- Never smoke when handling fuel, and stay away from an open flame or where fumes may be ignited by a spark.
- Store fuel in an approved container and keep it out of the reach of children. Never buy more than a 30-day supply of fuel.
- Do not operate without the entire exhaust system in place and in proper working condition.

⚠ DANGER

In certain conditions during fueling, static electricity can be released, causing a spark which can ignite the fuel vapors. A fire or explosion from fuel can burn you and others and can damage property.

- Always place fuel containers on the ground away from your vehicle before filling.
- Do not fill fuel containers inside a vehicle or on a truck or trailer bed because interior carpets or plastic truck bed liners may insulate the container and slow the loss of any static charge.
- When practical, remove the machine from the truck or trailer and refuel the machine with its wheels on the ground.
- If this is not possible, then refuel the machine on a truck or trailer from a portable container rather than from a fuel-dispenser nozzle.
- If you must use a fuel-dispenser nozzle, keep the nozzle in contact with the rim of the fuel tank or container opening at all times until fueling is complete.

1. Clean around the fuel-tank cap and remove it (Figure 22).

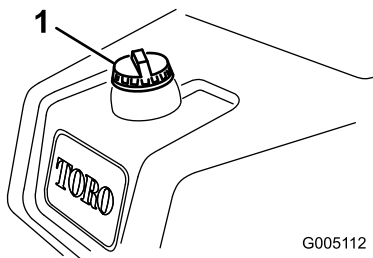

Figure 22

1. Fuel-tank cap

2. Add unleaded regular gasoline to the fuel tank until the level is 25 mm (1 inch) below the bottom of the filler neck.

This space in the tank allows the fuel to expand. **Do not fill the fuel tank completely full.**

3. Install the fuel tank cap securely. Wipe up any fuel that may have spilled.

Note: You will hear a click sound when the cap is secure.

Checking the Hydraulic-Fluid Level

The hydraulic-fluid reservoir is filled at the factory with approximately 25.7 L (6.8 US gallons) of high quality hydraulic fluid. Before operating the machine each day, check level of the hydraulic fluid in the white plastic window on the front of the hydraulic-fluid reservoir (behind the seat on the left side). The fluid should be between the lines in the window; if not, add an appropriate fluid as described in the following sections:

The recommended replacement fluid is as follows:

Toro Premium All Season Hydraulic Fluid (Available in 5-gallon pails or 55-gallon drums. See parts catalog or Toro distributor for part numbers.)

Alternate fluids: If the Toro fluid is not available, other fluids may be used provided they meet all the following material properties and industry specifications. We do not recommend the use of synthetic fluid. Consult with your lubricant distributor to identify a satisfactory product

Note: Toro will not assume responsibility for damage caused by improper substitutions, so use only products from reputable manufacturers who will stand behind their recommendation.

High Viscosity Index/Low Pour Point Anti-wear Hydraulic Fluid, ISO VG 46	
Material Properties:	
Viscosity, ASTM D445	cSt @ 40°C 44 to 48 cSt @ 100°C 7.9 to 8.5
Viscosity Index ASTM D2270	140 to 160

Pour Point, ASTM D97	-34°F to -49°F
Industry Specifications:	
Vickers I-286-S (Quality Level), Vickers M-2950-S (Quality Level), Denison HF-0	

Important: The ISO VG 46 Multigrade fluid has been found to offer optimal performance in a wide range of temperature conditions. For operation in consistently high ambient temperatures, 18° C (65° F) to 49° C (120° F), ISO VG 68 hydraulic fluid may offer improved performance.

Premium Biodegradable Hydraulic Fluid-Mobil EAL EnviroSyn 46H

Important: Mobil EAL EnviroSyn 46H is the only synthetic biodegradable fluid approved by Toro. This fluid is compatible with the elastomers used in Toro hydraulic systems and is suitable for a wide-range of temperature conditions. This fluid is compatible with conventional mineral oils, but for maximum biodegradability and performance the hydraulic system should be thoroughly flushed of conventional fluid. The oil is available in 19 L (5 gallon) containers or 55 gallon drums from your Mobil Distributor.

Important: Many hydraulic fluids are almost colorless, making it difficult to spot leaks. A red dye additive for the hydraulic system oil is available in 20 ml (2/3 oz) bottles. One bottle is sufficient for 15-22 L (4-6 gallons) of hydraulic fluid. Order part no. 44-2500 from your authorized Toro distributor. *This red dye is not recommended for use with biodegradable fluids. Use food coloring.*

Important: Regardless of the hydraulic fluid type used, any traction unit used for off green applications, verticutting or used during ambient temperatures above 29° C (85° F) should have Oil Cooler Kit installed; refer to [5 Installing the Oil Cooler \(optional\) \(page 14\)](#).

Filling the Hydraulic Tank

1. Position the machine on a level surface. Make sure the machine has cooled down so the oil is cold.
2. Remove the cap from the reservoir ([Figure 23](#)).

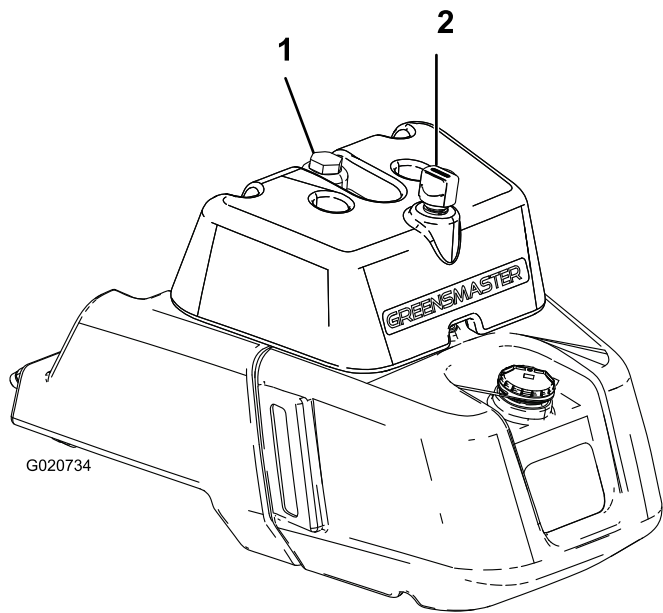

Figure 23

1. Hydraulic-tank cap
2. Breather

3. Slowly fill the reservoir with the appropriate hydraulic fluid until the level reaches the Full mark in the white window in the front of the reservoir. Do not overfill.

Important: To prevent system contamination, clean the top of the hydraulic fluid containers before puncturing. Ensure the pour spout and funnel are clean.

4. Install the reservoir cap. Wipe up any fluid that may have spilled.

Important: Check level of hydraulic fluid before engine is first started and daily thereafter.

Checking the Reel-to-Bedknife Contact

Each day before operating the machine, check the reel-to-bedknife contact, regardless if the quality of cut had previously been acceptable. There must be light contact across the full length of the reel and bedknife; refer to the Cutting Unit *Operator's Manual*.

Checking the Tire Pressure

Vary the tire pressure for the front wheels, depending upon your turf conditions, from a minimum of 83 to a maximum of 110 kPa (12 psi to 16 psi).

Vary the tire pressure for the rear wheel from a minimum of 83 to a maximum of 110 kPa (12 psi to 16 psi).

Checking the Torque of the Wheel Nuts

⚠ WARNING

Failure to maintain proper torque of the wheel nuts could result in personal injury.

Torque the wheel nuts to 95 to 122 N·m (70-90 ft-lb) after 1-4 hours of operation and again after 10 hours of operation. Torque every 200 hours thereafter.

To ensure even distribution, torque the brakes in a star pattern.

Breaking in the Machine

Refer to the engine manual supplied with the machine for oil change and maintenance procedures recommended during the break-in period.

Only 8 hours of mowing operation is required for the break-in period.

Since the first hours of operation are critical to future dependability of the machine, monitor its functions and performance closely so that minor difficulties, which could lead to major problems, are noted and can be corrected. Inspect the machine frequently during break-in for signs of oil leakage, loose fasteners, or any other malfunction.

Starting and Stopping the Engine

Note: Inspect the areas beneath the mowers to be certain they are clear of debris.

Starting the Engine

Note: Inspect the area beneath the mowers to be certain they are clear of debris.

1. Sit on the seat, lock the parking brake, disengage the raise/lower mow control and move the functional-control lever to the NEUTRAL position.
2. Remove your foot from the traction pedal and make sure the pedal is in the NEUTRAL position.
3. Move the choke lever to the CLOSED position (only when starting a cold engine) and the throttle lever to the HALF THROTTLE position.
4. Insert and rotate the ignition key clockwise until the engine starts.
5. After the engine starts, regulate the choke to keep the engine running smoothly. As soon as possible, open the choke by pulling it rearward to the OFF position. A warm engine requires little or no choking.
6. Check the machine out with the following procedures after the engine has started:

- A. Move the throttle lever to the FAST position and momentarily engage the reels by moving the raise/lower mow control lever forward. The cutting units should drop and all the reels should turn.
- B. Move the raise/lower mow control lever rearward. The cutting reels should stop and the cutting units should raise to the full transport position.
- C. Set the brake to keep the machine from moving, and operate the traction pedal through the forward and reverse positions.
- D. Continue the above procedure for 1-2 minutes. Move the functional-control lever to the NEUTRAL position, lock the parking brake, and turn the engine off.
- E. Check for oil leaks and tighten the hydraulic fittings if any are found.

Note: When the machine is new and the bearings and reels are tight, it is necessary to use the FAST throttle lever position for this check. A fast throttle setting may not be required after the break-in period.

Note: If oil leaks continue to appear, contact your Authorized Toro Distributor for assistance and, if necessary, replacement parts.

Important: A trace of oil on the motor or wheel seals is normal. Seals require a small amount of lubrication to perform properly.

Stopping the Engine

1. Move the throttle lever to the SLOW position, disengage the raise/lower mow control, and move the functional-control lever to the NEUTRAL position.
2. Rotate the starter key to the OFF position to shut the engine off. Remove the key from the switch to prevent accidental starting.
3. Close the fuel shut-off valves before storing the machine.

Checking the Safety-Interlock System

▲ CAUTION

If the safety interlock switches are disconnected or damaged the machine could operate unexpectedly causing personal injury.

- Do not tamper with the interlock switches.
- Check the operation of the interlock switches daily and replace any damaged switches before operating the machine.

The purpose of the safety-interlock system is to prevent operation of the machine where there is possible injury to the operator or damage to the machine.

- The traction pedal is in the NEUTRAL position.
- The functional-control lever is in the NEUTRAL position.

The safety-interlock system prevents the machine from moving unless:

- The parking brake is off.
- The operator is seated.
- The functional-control lever is in the MOW position or the TRANSPORT position.

The safety-interlock system prevents the reels from operating unless the functional-control lever is in the MOW position.

Perform the following system checks daily to ensure that the interlock system is operating correctly:

1. Sit on the seat, move the traction pedal to the NEUTRAL position, move the functional-control lever to the NEUTRAL position, and engage the parking brake.
2. Try to press the traction pedal.

The pedal should not press, which means that the interlock system is operating correctly. Correct the problem if it is not operating properly.

3. Sit on the seat, move the traction pedal to the NEUTRAL position, move the functional-control lever to the NEUTRAL position, and engage the parking brake.
4. Move the functional-control lever to the MOW position or the TRANSPORT position and try to start the engine.

The engine should not turn-over or start, which means that the interlock system is operating correctly. Correct the problem if it is not operating properly.

5. Sit on the seat, move the traction pedal to the NEUTRAL position, move the functional-control lever to the NEUTRAL position, and engage the parking brake.
6. Start the engine and move the functional-control lever to the MOW position or the TRANSPORT position.

The engine should kill, which means that the interlock system is operating correctly.

Correct the problem if it is not operating properly.

7. Sit on the seat, move the traction pedal to the NEUTRAL position, move the functional control lever to the NEUTRAL position, and engage the parking brake.
8. Start the engine.
9. Release the parking brake, move the functional control lever to the MOW position, and rise from the seat.

The engine should shut off, which means that the interlock system is operating correctly. Correct the problem if it is not operating properly.

10. Sit on the seat, move the traction pedal to the NEUTRAL position, move the functional control lever to the NEUTRAL position, and engage the parking brake.
11. Start the engine.
12. Move the raise/lower mow control forward to lower the cutting units. The cutting units should lower but not start rotating.

If they start rotating, the interlock system is not operating correctly; correct the problem before operating the machine.

Checking the Leak Detector

The leak detector system is designed to assist in early detection of hydraulic-fluid-system leaks. If the oil level in the main hydraulic reservoir, is lowered by 118 to 177 ml (4 to 6 oz), the float switch in the tank will close. After a 1 second delay, the alarm will sound, alerting the operator (Figure 26). Expansion of oil, due to normal heating during machine operation, will cause the oil to transfer into the auxiliary oil reservoir. The oil is allowed to return to the main tank when the ignition switch is turned off.

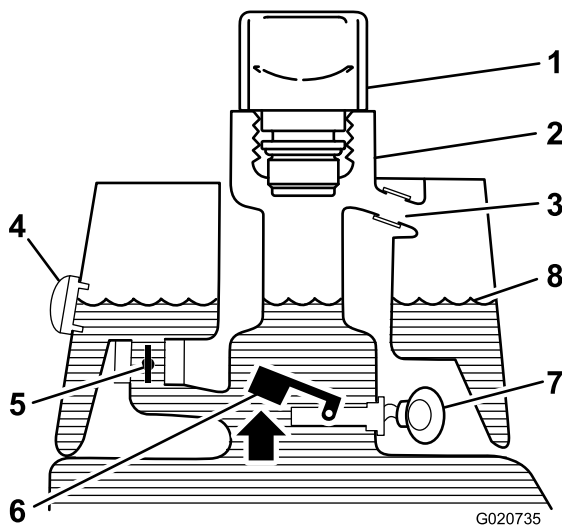

Figure 24

Before start (oil cold)

- | | |
|------------------|-------------------------------|
| 1. Breather cap | 5. Solenoid-return valve—open |
| 2. Filler neck | 6. Float-raised switch— open |
| 3. Overflow tube | 7. No sound |
| 4. Sight window | 8. Fluid level (cold) |

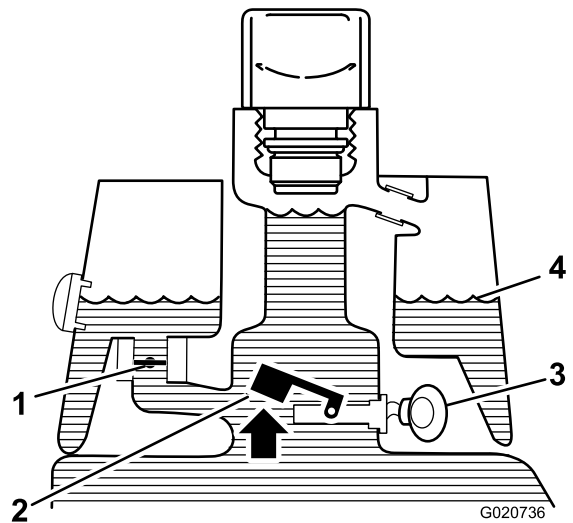

Figure 25

Normal operation (oil warm)

- | | |
|---------------------------------|-----------------------|
| 1. Solenoid-return valve—closed | 3. Warning buzzer |
| 2. Float-raised—switch open | 4. Fluid level (warm) |

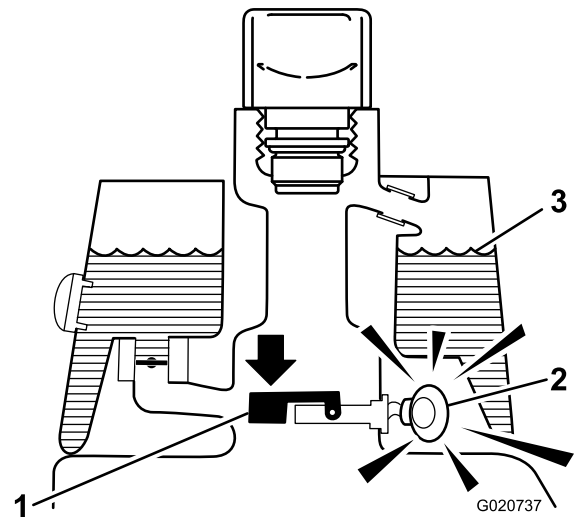

Figure 26

Leak Alert!

- | | |
|--|-----------------------|
| 1. Float-down—switch closed
Fluid level down 118–177 ml (4 to 6 ounces) | 3. Fluid level (warm) |
| 2. Warning buzzer | |

Checking the Leak-Detector System Operation

1. Move the ignition switch to the ON position. Do not start the engine.
2. Remove the hydraulic-tank cap and strainer from the neck of the tank.

- Insert a clean rod or screwdriver into the tank neck and gently push down on the switch float (Figure 27). The alarm should sound after the one-second delay.

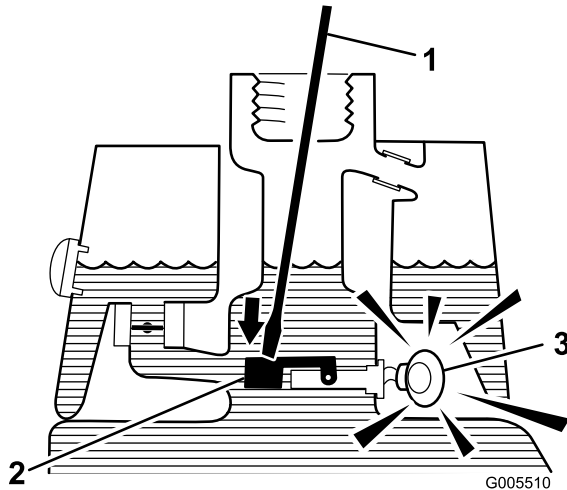

Figure 27

- Clean rod or screwdriver
- Press down on the switch
- Warning buzzer

- Release the float.

Note: The alarm should stop sounding.

- Install the strainer screen and hydraulic tank cap. Move the ignition switch to the OFF position.

Operating the Leak Detector

The leak detector alarm may sound for one of the following reasons:

- A leak of 118 to 177 ml (4 to 6 oz) has occurred.
- The oil level in the main reservoir is reduced by 118 to 177 ml (4 to 6 oz) due to contraction of the oil by cooling.

If the alarm sounds, turn off the machine as quickly as possible and inspect it for leaks. If the alarm sounds while operating on a green, drive off the green first. Determine the source of the leak and repair it before continuing operation.

If you do not find a leak and suspect a false alarm, move the ignition switch to the OFF position and allow the machine to stand for 1 to 2 minutes to allow the oil levels to stabilize. Then start the machine and operate it in a non-sensitive area to confirm that no leak exists.

False alarms, due to oil contraction, may be caused by extended idling of the machine after normal operation. A false alarm may also occur if you work the machine at a reduced workload after an extended period of a heavier workload. To avoid false alarms, turn the machine off rather than idling for extended periods.

Installing and Removing the Cutting Units

Note: When sharpening, setting the height-of-cut, or performing other maintenance procedures on the cutting units, store the cutting unit reel motors in the storage location on the front of the suspension arms to prevent damage to them.

Important: Do not raise the suspension to the transport position when the reel motors are in the holders in the machine frame. Damage to the motors or hoses could result.

Important: Whenever you need to tip the cutting unit, prop up rear of cutting unit to ensure that the nuts on the bedbar adjusting screws are not resting on work surface (Figure 28).

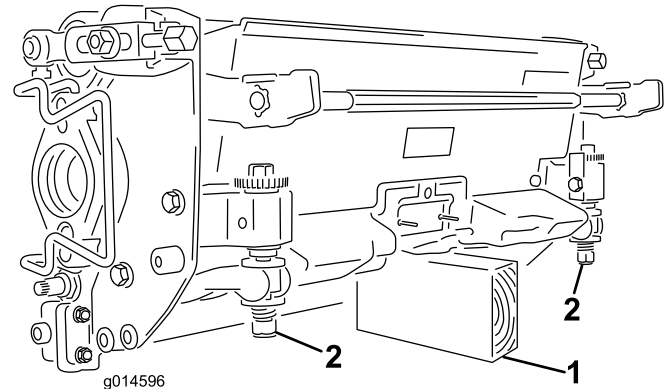

Figure 28

- Prop (not provided)
- Bedbar-adjusting-screw nut (2)

Installing the Cutting Units

- Lift up on the foot rest and swing it open, allowing access to the center cutting unit position (Figure 29).

CAUTION

The foot rest can pinch fingers if it falls into the closed position.

Keep your fingers clear of the area where the foot rest seats while it is open.

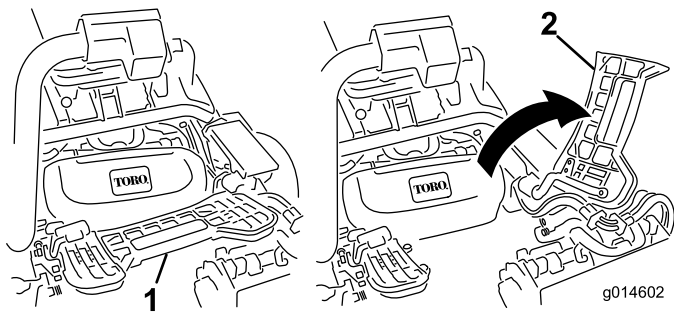

Figure 29

1. Footrest—closed 2. Footrest—open

2. Position the cutting unit under the center suspension arm.
3. With the latches on the suspension-arm bar pointing up (i.e., open) (Figure 30), push the suspension arm down so that the bar fits over the bar across the top of the cutting unit (Figure 31).

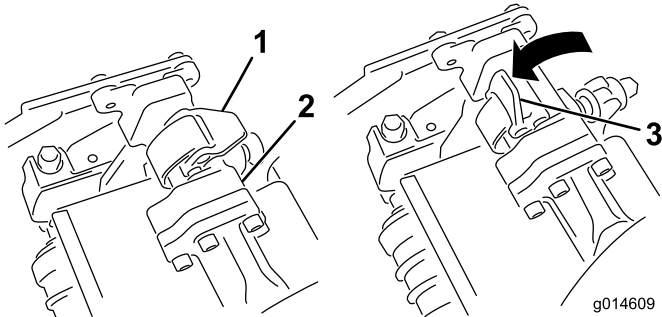

Figure 30

1. Latch—closed position 3. Latch—open position
2. Suspension-arm bar

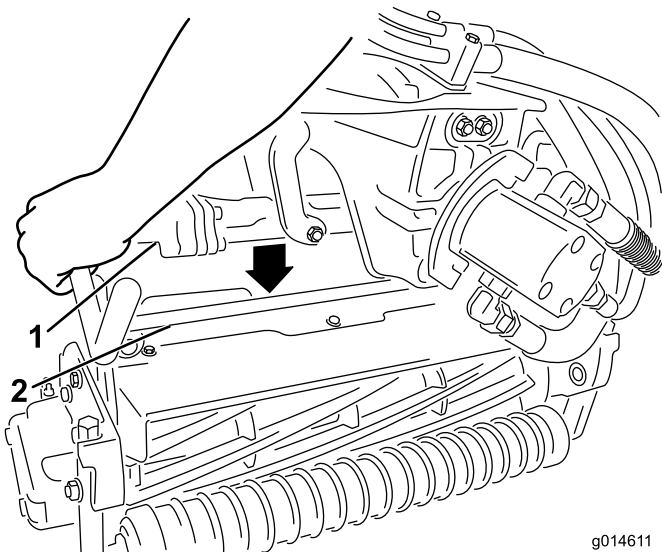

Figure 31

1. Suspension-arm bar 2. Cutting-unit bar

4. Close the latches down and around the cutting-unit bar and lock them in place (Figure 30).

Note: A “click” can be heard and felt when the latches are properly locked in place.

5. Coat the spline shaft of the cutting unit motor with clean grease (Figure 32).
6. Insert the motor into the left side of the cutting unit (as viewed from the operator's position) and pull the motor retaining bar on the cutting unit toward the motor until you hear an audible “click” from both sides of the motor (Figure 32).

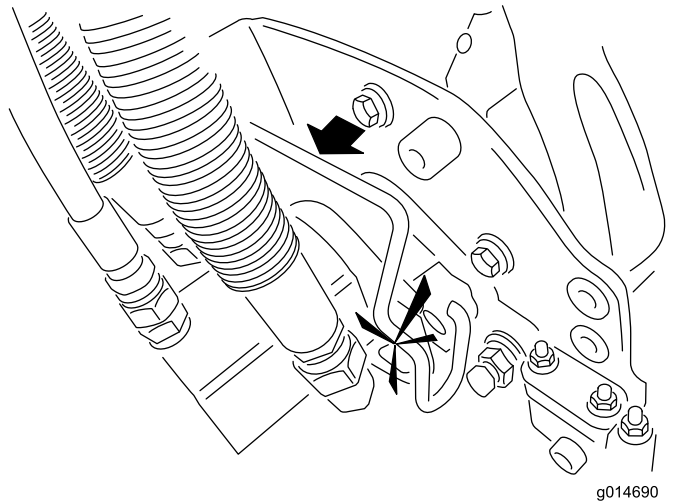
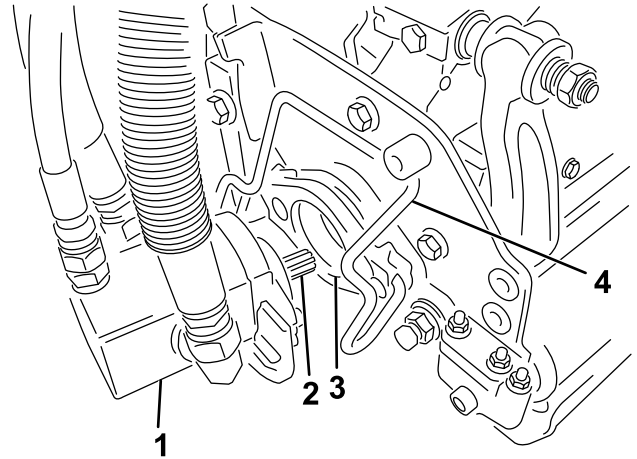

Figure 32

1. Reel motor 3. Cavity
2. Spline shaft 4. Motor-retaining bar

7. Mount a grass basket onto the basket hooks on the suspension arm.
8. Repeat this procedure for the other cutting units.

Removing the Cutting Units

1. Park the machine on a clean level surface, lower the cutting units to the ground until the suspension hydraulics are fully extended, stop the engine, and set the parking brake.

- Push the motor retaining bar out of the slots on the motor towards the cutting unit and remove the motor from the cutting unit.

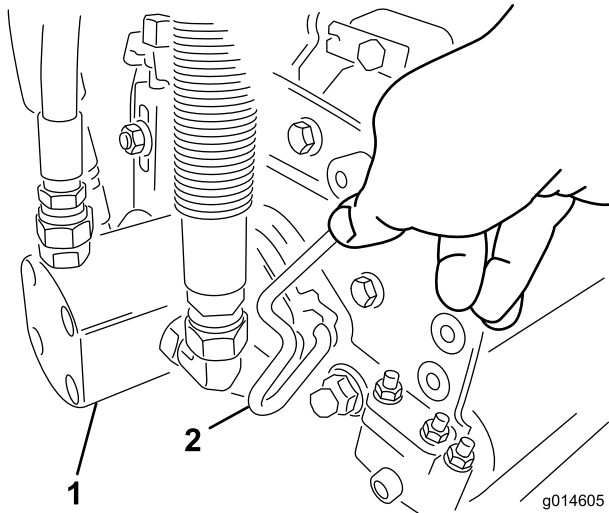

Figure 33

- Reel motor
- Motor-retaining bar

- Move the motor to the storage location on the front of the suspension arm (Figure 34).

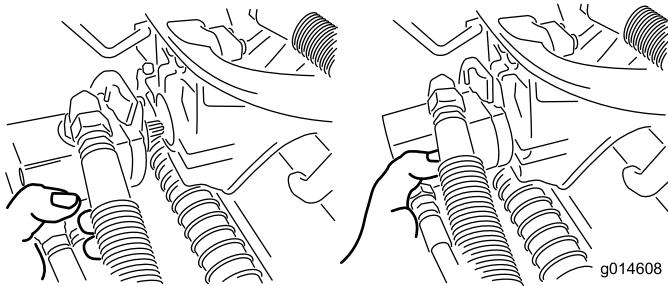

Figure 34

Note: When sharpening, setting the height-of-cut, or performing other maintenance procedures on the cutting units, store the cutting unit reel motors in the storage location on the front of the suspension arms to prevent damage to them.

Important: Do not raise the suspension to the transport position when the reel motors are in the holders in the machine frame. Damage to the motors or hoses could result. If you must move the traction unit without the cutting units installed, secure them to the suspension arms using cable ties.

- Open the latches on the suspension-arm bar of the cutting unit you are removing (Figure 30).
- Disconnect the latches from the cutting-unit bar.
- Roll the cutting unit out from under the suspension arm.
- Repeat steps 2 through 6 for the other cutting units as required.

Setting the Reel Speed

To achieve a consistent, high-quality cut and a uniform, after-cut appearance, you must correctly set the reel speed control (located on the manifold block under the cover to the left of the seat). Adjust the reel speed control as follows:

- Select the height-of-cut at which the cutting units are set.
- Choose the desired ground speed best suited for conditions.
- Using the appropriate graph (See Figure 35) for 5, 8, 11, or 14 blade cutting units, determine the proper reel speed setting.

	5		8		11		14
	3.8 MPH 6.1 Km/h	5.0 MPH 8.0 Km/h	3.8 MPH 6.1 Km/h	5.0 MPH 8.0 Km/h	3.8 MPH 6.1 Km/h	5.0 MPH 8.0 Km/h	3.8 MPH 6.1 Km/h
0.062" / 1.6mm	N/R	N/R	9	N/R	9	N/R	9
0.094" / 2.4mm	N/R	N/R	9	N/R	9	N/R	9
0.125" / 3.2mm	N/R	N/R	9	N/R	9	N/R	9
0.156" / 4.0mm	N/R	N/R	9	N/R	9	N/R	N/R
0.188" / 4.8mm	N/R	N/R	9	N/R	7	N/R	N/R
0.218" / 5.5mm	N/R	N/R	9	N/R	6	N/R	N/R
0.250" / 6.4mm	7	N/R	6	7	5	7	N/R
0.312" / 7.9mm	6	N/R	5	6	4	6	N/R
0.375" / 9.5mm	6	7	4	5	4	5	N/R
0.438" / 11.1mm	6	6	4	5	3	4	N/R
0.500" / 12.7mm	5	6	3	4	N/R	N/R	N/R
0.625" / 15.9mm	4	5	3	3	N/R	N/R	N/R
0.750" / 19.0mm	3	4	3	3	N/R	N/R	N/R
0.875" / 22.2mm	3	4	N/R	3	N/R	N/R	N/R
1.000" / 25.4mm	3	3	N/R	N/R	N/R	N/R	N/R

g014736

Figure 35

- To set the reel speed, rotate the knob (Figure 36) until the indicator arrows are in line with the number designating desired setting.

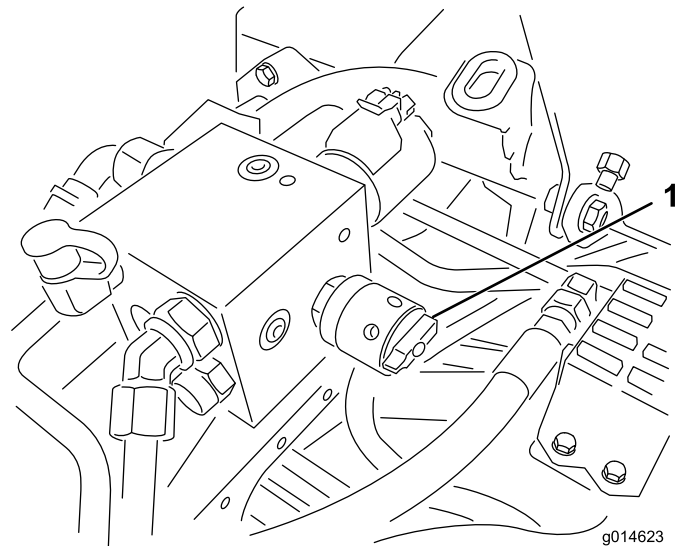

Figure 36

- Reel-speed control

Note: You can increase or decrease the reel speed to compensate for turf conditions.

Mowing

Before mowing greens, find a clear area and practice starting and stopping the machine, raising and lowering the cutting units, turning, etc.

Inspect the green for debris, remove the flag from the cup, and determine the best direction to mow. Base the direction to mow on the previous mowing direction. Always mow in an alternate pattern from the previous mowing so that the grass blades will be less apt to lay down and therefore be difficult to trap between the reel blades and the bedknife.

1. Approach the green with the functional-control lever in the MOW position and the throttle at full speed.
2. Start on one edge of the green so that you can use the ribbon procedure of cutting.

Note: This holds compaction to a minimum and leaves a neat, attractive pattern on the greens.

3. Actuate the raise/lower mow lever as the front edges of the grass baskets cross the outer edge of the green.

Note: This procedure drops the cutting units to the turf and starts the reels.

Important: The No. 1 cutting unit reel is delayed; therefore, you should practice to gain the required timing necessary to minimize the cleanup mowing operation.

4. Overlap a minimal amount with the previous cut on return passes.

Note: To assist in maintaining a straight line across the green and keep the machine an equal distance from the edge of the previous cut, establish an imaginary sight line approximately 1.8 to 3 m (6 to 10 ft) ahead of the machine to the edge of the uncut portion of the green (Figure 37). Some find it useful to include the outer edge of the steering wheel as part of the sight line; i.e. keep the steering wheel edge aligned with a point that is always kept the same distance away from the front of the machine.

5. As the front edges of the baskets cross the edge of the green, move the raise/lower mow lever rearward and hold it until all the cutting units have risen. This will stop the reels and lift the cutting units.

Note: It is important to time this step correctly so that you do not cut into the fringe area yet cut as much of the green as possible to minimize the amount of grass left to mow around the outer periphery.

6. To cut down on operating time and ease lineup for the next pass, momentarily turn the machine in the opposite direction, then turn it in the direction of the uncut portion; i.e., if intending to turn right, first swing slightly left, then right.

Note: This will assist in getting the machine more quickly aligned for the next pass. Try to make as short

of a turn as possible except during warmer weather when a wider arc will minimize the turf bruising.

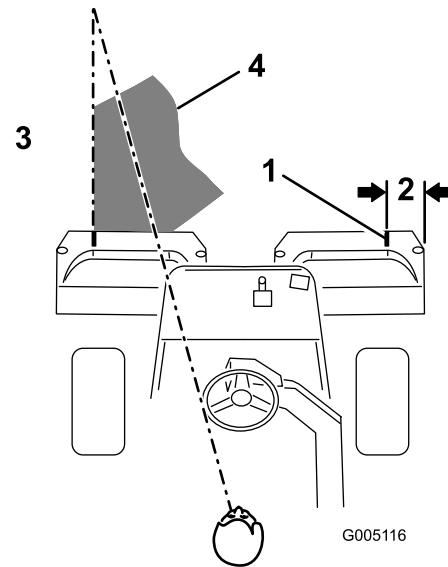

Figure 37

- | | |
|-------------------------------------|--|
| 1. Alignment strip | 3. Cut grass on the left |
| 2. Approximately 12.7 cm (5 inches) | 4. Keep a focal spot 2 to 3 m (6 to 10 ft) ahead of the machine. |

Note: Due to the nature of the power steering system, the steering wheel will not return to its original position after a turn has been completed.

Important: Never stop on a green with the cutting unit reels operating as damage to the turf may result. Stopping on a wet green with the machine may leave marks or indentations from the wheels.

7. If the leak detector alarm sounds while cutting on a green, immediately raise the cutting units, drive directly off the green and stop the machine in an area away from the green. Determine the cause of the alarm and correct the problem.
8. Finish cutting the green by mowing the outer periphery. Be sure to change the direction of cutting from the previous mowing.

Note: Always keep weather and turf conditions in mind and be sure to change the direction of mowing from the previous cutting.

9. When finished mowing the outer periphery, tap the raise/lower mow lever rearward to stop the reels, then drive off the green. When all of the cutting units are off of the green, raise them.

Note: This will minimize grass clumps left on the green.

10. Replace the flag.
11. Empty the grass baskets of all clippings before transporting to the next green.

Note: Heavy wet clippings place an undue strain on the baskets and will add unnecessary weight to the machine, thereby increasing the load on the engine, hydraulic system, brakes, etc.

Inspecting and Cleaning after Mowing

At the completion of the mowing operation, thoroughly wash the machine with a garden hose without a nozzle so excessive water pressure will not cause contamination and damage to the seals and bearings. **Never wash a warm engine or electrical connections with water.**

After cleaning, inspect the machine for possible hydraulic fluid leaks, damage or wear to hydraulic and mechanical components, and the cutting units for sharpness. Also, lubricate brake shaft assembly with SAE 30 oil or spray lubricant to deter corrosion and help keep the machine performing satisfactorily during the next mowing operation.

Driving the Machine without Mowing

Ensure that the cutting units are fully raised. Move the functional-control lever to the TRANSPORT position. Use the brakes to slow the machine while going down steep hills to avoid loss of control. Always approach rough areas at a reduced speed and cross severe undulations carefully. Familiarize yourself with the width of the machine. Do not attempt to pass between objects that are close together so that costly damage and down time can be prevented.

Transporting the Machine

Use a heavy-duty trailer or truck to transport the machine. Ensure that the trailer or truck has all necessary brakes, lighting, and marking as required by law. Read all the safety instructions. Knowing this information could help you, your family, pets, or bystanders avoid injury.

⚠ WARNING

Driving on the street or roadway without turn signals, lights, reflective markings, or a slow moving vehicle emblem is dangerous and can lead to accidents causing personal injury.

Do not drive the machine on a public street or roadway.

Use extreme caution when loading the machine onto a trailer or a truck. One full-width ramp that is wide enough to extend beyond the rear tires is required (Figure 38).

The ramp should be long enough so that the angles do not exceed 15 degrees (Figure 38). A steeper angle may cause

mower components to get caught as the unit moves from the ramp to the trailer or truck. Steeper angles may also cause the machine to tip backward. If loading on or near a slope, position the trailer or truck so that it is on the down side of the slope and the ramp extends up the slope. This will minimize the ramp angle. The trailer or truck should be as level as possible.

Important: Do not attempt to turn the machine while on the ramp; you may lose control and drive off the side.

Avoid sudden acceleration when driving up a ramp and sudden deceleration when backing down a ramp. Both maneuvers can cause the machine to tip backward.

⚠ WARNING

Loading a machine onto a trailer or truck increases the possibility of backward tip-over and could cause serious injury or death.

- Use extreme caution when operating a machine on a ramp.
- Use the seat belt when loading the machine. Ensure that the ROPS will clear the top of an enclosed trailer.
- Use only a single, full-width ramp; do not use individual ramps for each side of the machine.
- If individual ramps must be used, use enough ramps to create an unbroken ramp surface wider than the machine.
- Do not exceed a 15-degree angle between the ramp and the ground or between the ramp and the trailer or truck.
- Avoid sudden acceleration while driving the machine up a ramp, to avoid tipping backward.
- Avoid sudden deceleration while backing the machine down a ramp, to avoid tipping backward.

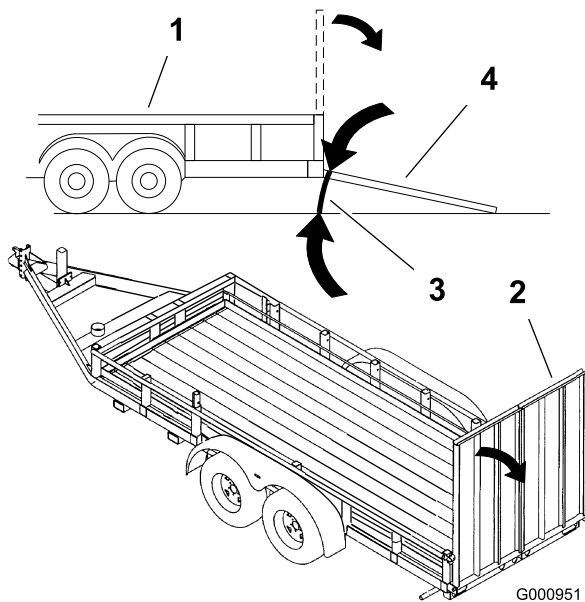

Figure 38

- | | |
|--------------------|--------------------------------|
| 1. Trailer | 3. Not greater than 15 degrees |
| 2. Full-width ramp | 4. Full-width ramp—side view |

1. If using a trailer, connect it to the towing vehicle and connect the safety chains.
2. If applicable, connect the trailer brakes.
3. Load the machine onto the trailer or truck.
4. Stop the engine, remove the key, set the parking brake, and close the fuel valve.
5. Use the metal tie-down loops on the machine to securely fasten the machine to the trailer or truck with straps, chains, cable, or ropes.

Towing the Machine

In case of an emergency, you can tow the machine for a short distance, less than 0.4 km (1/4 mile); however, Toro does not recommend this as standard procedure.

Important: Do not tow the machine faster than 3 to 5 km/h (2 to 3 mph) because the drive system may be damaged. If the machine must be moved a considerable distance, transport it on a truck or trailer.

1. Locate the bypass valve on the pump and rotate it so that the slot is vertical (Figure 39).

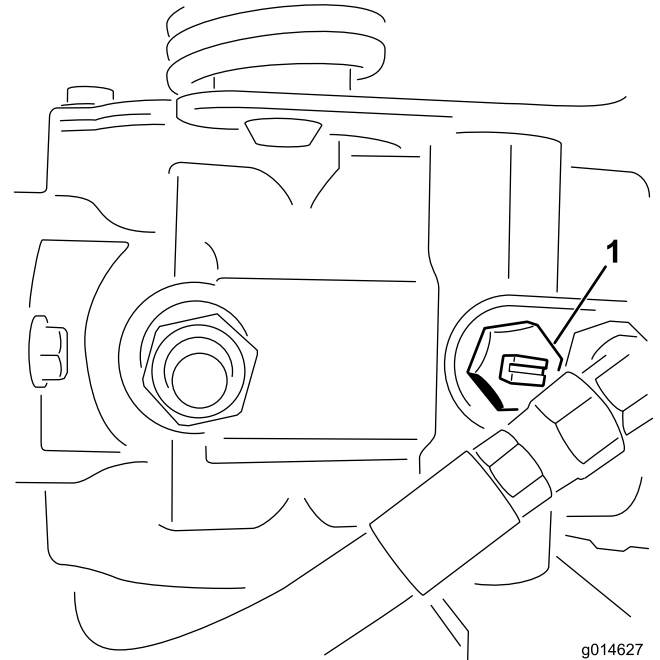

Figure 39

1. Bypass valve-slot shown in closed (horizontal) position
-
2. Before starting the engine, close the bypass valve by rotating it so that the slot is horizontal (Figure 39). Do not start the engine when the valve is open.

Maintenance

Note: Determine the left and right sides of the machine from the normal operating position.

Note: Download a free copy of the electrical or hydraulic schematic by visiting www.Toro.com and searching for your machine from the Manuals link on the home page.

Important: Refer to your engine owner's manual for additional maintenance procedures.

⚠ CAUTION

If you leave the key in the ignition switch, someone could accidentally start the engine and seriously injure you or other bystanders.

Remove the key from the ignition and disconnect the wires from the spark plugs before you do any maintenance. Set the wires aside so that they do not accidentally contact the spark plugs.

Recommended Maintenance Schedule(s)

Maintenance Service Interval	Maintenance Procedure
After the first hour	<ul style="list-style-type: none">• Check the torque of the wheel nuts.
After the first 10 hours	<ul style="list-style-type: none">• Check the torque of the wheel nuts.
After the first 25 hours	<ul style="list-style-type: none">• Change the engine oil and filter.
After the first 50 hours	<ul style="list-style-type: none">• Change the hydraulic-oil filter.• Check the engine speed (at idle and full throttle).
Before each use or daily	<ul style="list-style-type: none">• Check the engine oil.• Check the hydraulic fluid level.• Check the reel-to-bedknife contact.• Check the safety-interlock system.• Check the hydraulic lines and hoses.
Every 50 hours	<ul style="list-style-type: none">• Service the air-cleaner foam element (more frequently when operating conditions are dusty or dirty).• Check the battery electrolyte level.• Check the battery cable connections.
Every 100 hours	<ul style="list-style-type: none">• Service the air-cleaner paper element (more frequently when operating conditions are dusty or dirty).• Change the engine oil and filter.
Every 200 hours	<ul style="list-style-type: none">• Check the torque of the wheel nuts.
Every 400 hours	<ul style="list-style-type: none">• Grease the machine.
Every 800 hours	<ul style="list-style-type: none">• Replace the spark plugs.• Replace the fuel filter. (Sooner if the fuel flow is restricted)• Change the hydraulic fluid, filter, and tank breather.• Check the engine speed (at idle and full throttle).• Check the valve clearance.
Every 2 years	<ul style="list-style-type: none">• Check the fuel lines and connections.• Replace moving hoses.

Daily Maintenance Checklist

Duplicate this page for routine use.

Maintenance Check Item	For the week of:						
	Mon.	Tues.	Wed.	Thurs.	Fri.	Sat.	Sun.
Check the safety-interlock operation.							
Check the instrument operation							
Check the leak-detector alarm.							
Check the brake operation.							
Check the fuel level.							
Check the hydraulic-fluid level.							
Check the engine-oil level.							
Clean the engine, air-cooling fins.							
Inspect the air-filter pre-cleaner.							
Check any unusual engine noises.							
Check the reel-to-bedknife adjustment.							
Check the hydraulic hoses for damage.							
Check for fluid leaks.							
Check the tire pressure.							
Check the height-of-cut adjustment.							
Touch-up damaged paint.							

Notation for Areas of Concern		
Inspection performed by:		
Item	Date	Information

Engine Maintenance

Servicing the Air Cleaner

Service Interval: Every 50 hours—Service the air-cleaner foam element (more frequently when operating conditions are dusty or dirty).

Every 100 hours—Service the air-cleaner paper element (more frequently when operating conditions are dusty or dirty).

1. Clean the cover thoroughly (Figure 40).

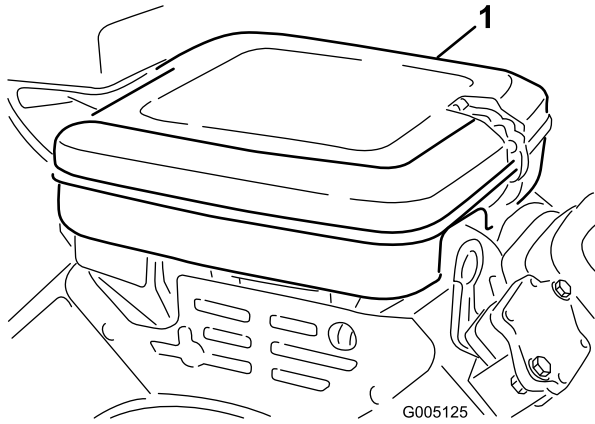

Figure 40

1. Air-cleaner cover

2. Release the locking clips and remove the air-cleaner cover.
3. Remove the wing nut securing the elements to the air-cleaner body (Figure 41).
4. If the foam element is dirty, remove it from the paper element (Figure 41). Clean it thoroughly, as follows:
 - A. Wash the foam element in a solution of liquid soap and warm water. Squeeze it to remove dirt, but do not twist it because the foam may tear.
 - B. Dry it by wrapping it in a clean rag. Squeeze the rag and foam element dry.

Important: Do not twist the foam element when drying it.

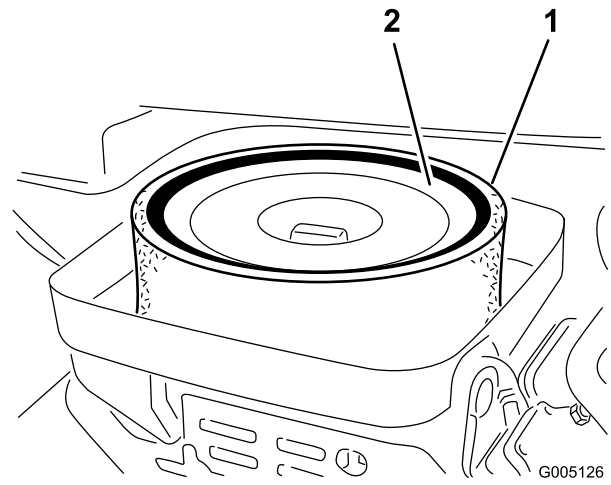

Figure 41

1. Foam element
2. Paper element
3. Wing nut

5. When servicing the foam element, check the condition of the paper element. Clean it by gently tapping it on a flat surface or replace it if needed.
6. Install the foam element, paper element, wing nut, and air-cleaner cover.

Important: Do not operate the engine without the air cleaner element because extreme engine wear and damage will likely result.

Changing the Engine Oil and Filter

Service Interval: After the first 25 hours—Change the engine oil and filter.

Every 100 hours

1. Remove the drain plug (Figure 42) and let the oil flow into a drain pan. When the oil stops, install the drain plug.

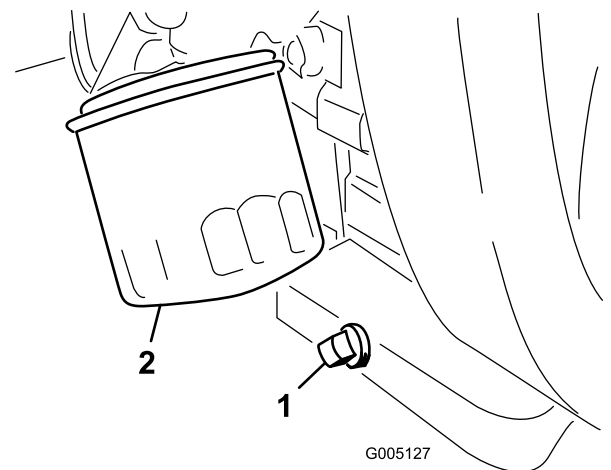

Figure 42

1. Drain plug
2. Oil filter

- Remove the oil filter (Figure 42).
- Apply a light coat of clean oil to the new filter gasket.
- Screw the filter on by hand until the gasket contacts the filter adapter, then tighten it 3/4 to 1 turn further. **Do not overtighten it.**
- Add oil to the crankcase; refer to [Checking the Engine Oil](#) (page 20).
- Dispose of the oil filter and used oil properly.

Replacing the Spark Plugs

Service Interval: Every 800 hours

The recommended air gap is 0.76 mm (0.030 inch)

The correct spark plug to use is a Champion RC 14YC.

Note: The spark plug usually lasts a long time; however, remove and check the plugs whenever the engine malfunctions.

- Clean the area around the spark plugs so foreign matter cannot fall into the cylinder.
- Pull the wires off of the spark plugs and remove the plugs.
- Check the condition of the side electrode, center electrode, and center electrode insulator to ensure that there is no damage.

Important: Replace a cracked, fouled, dirty, or otherwise malfunctioning spark plug. Do not sand blast, scrape, or clean electrodes by using a wire brush because grit may eventually release from the plug, fall into the cylinder, and damage the engine.

- Set the air gap between the center and side of the electrodes at 0.76 mm (0.030 inch) (Figure 43).

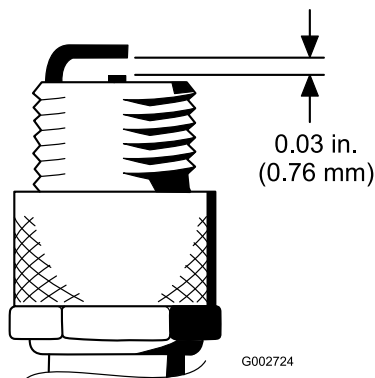

Figure 43

- Install the correctly-gapped spark plug with a gasket seal, and tighten the plug to 23 N·m (200 in-lb). If you do not have a torque wrench, tighten the plug firmly.

Fuel System Maintenance

Replacing the Fuel Filter

Service Interval: Every 800 hours (Sooner if the fuel flow is restricted)

An in-line filter is incorporated into the fuel line between the fuel tank and carburetor (Figure 44).

⚠ DANGER

In certain conditions, fuel is extremely flammable and highly explosive. A fire or explosion from fuel can burn you and others and can damage property.

- Drain fuel from the fuel tank when the engine is cold. Do this outdoors in an open area. Wipe up any fuel that spills.**
- Never smoke when draining fuel, and stay away from an open flame or where a spark may ignite the fumes.**

- Close the fuel-shutoff valve, loosen the hose clamp on the carburetor side of filter, and remove the fuel line from the filter (Figure 44).

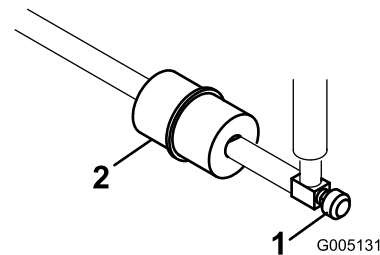

Figure 44

- Fuel-shutoff valve
- Fuel filter

- Place a drain pan under the filter, loosen the remaining hose clamp and remove the filter (Figure 44).
- Install the new filter with the arrow on the filter body pointing away from the fuel tank.

Inspecting the Fuel Lines and Connections

Service Interval: Every 2 years

Inspect the fuel lines for deterioration, damage, or loose connections.

Electrical System Maintenance

Servicing the Battery

Properly maintain the battery electrolyte and keep the top of the battery clean. Store the machine in a cool place to prevent the battery from running down.

Check the electrolyte level every 50 operating hours or, if machine is in storage, every 30 days.

⚠ DANGER

Battery electrolyte contains sulfuric acid which is a deadly poison and causes severe burns.

- Do not drink electrolyte and avoid contact with skin, eyes or clothing. Wear safety glasses to shield your eyes and rubber gloves to protect your hands.
- Fill the battery where clean water is always available for flushing the skin.

Maintain the cell level with distilled or demineralized water. Do not fill the cells above the bottom of the split ring inside each cell.

Keep the top of the battery clean by washing it periodically with a brush dipped in ammonia or bicarbonate of soda solution. Flush the top surface with water after cleaning it. Do not remove the fill caps while cleaning the battery.

The battery cables must be tight on the terminals to provide good electrical contact.

⚠ WARNING

Incorrect battery cable routing could damage the tractor and cables causing sparks. Sparks can cause the battery gasses to explode, resulting in personal injury.

- Always disconnect the negative (black) battery cable before disconnecting the positive (red) cable.
- Always connect the positive (red) battery cable before connecting the negative (black) cable.

If corrosion occurs at the terminals, disconnect the cables, negative (-) cable first, and scrape the clamps and terminals separately. Reconnect the cables, positive (+) cable first, and coat the terminals with petroleum jelly.

⚠ WARNING

CALIFORNIA
Proposition 65 Warning

Battery posts, terminals, and related accessories contain lead and lead compounds, chemicals known to the State of California to cause cancer and reproductive harm.
Wash hands after handling.

Locating the Fuses

The fuses in the electrical system are located under the seat (Figure 45).

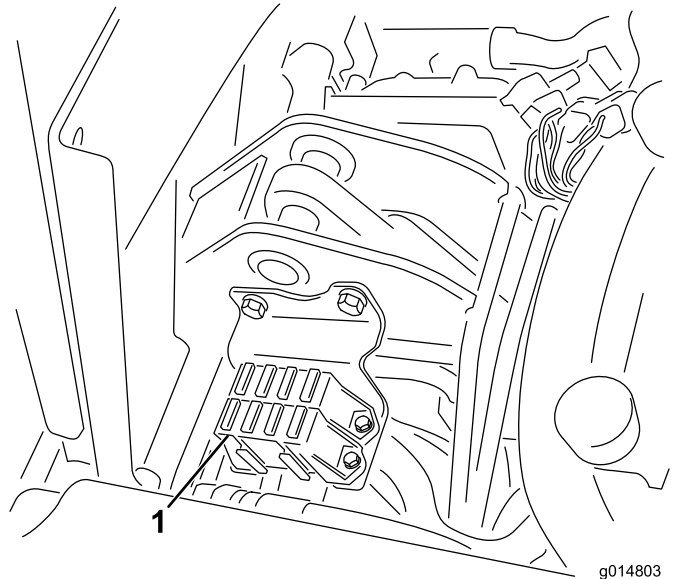

Figure 45

1. Fuses

Fuse Layout	
Hydraulic Fan Kit 15 A	Lift Reel E-Reel Enable 7.5 A
	Reel Engage Lift/Lower 7.5 A
Lights Leak Detector 15 A	Start/Run Diag. Lights Leak Detector 7.5 A
Run 10 A	ECM Logic Power 2 A

Drive System Maintenance

Adjusting the Transmission for Neutral

If the machine creeps when the traction-control pedal is in the NEUTRAL position, adjust the neutral-return mechanism.

1. Block up under the frame so that one of the front wheels is off of the floor.
Note: If machine is equipped with a 3-Wheel Drive Kit, also raise and block rear wheel.
2. Start the engine, move the throttle to the SLOW position, and ensure that the front wheel that is off of the floor is not rotating.
3. If the wheel is rotating, shut off the engine and proceed as follows:
 - A. Loosen the nut securing the eccentric to the top of the hydrostat (Figure 46).

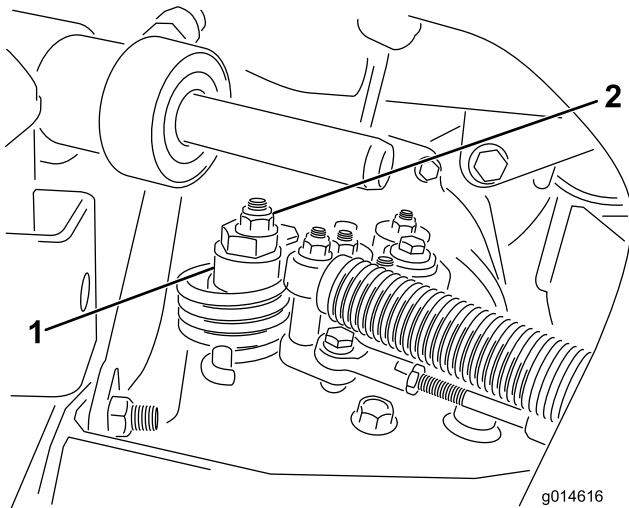

Figure 46

1. Eccentric
2. Locknut

- B. Move the functional-control lever to the NEUTRAL position and the throttle to the SLOW position. Start the engine.
- C. Rotate the eccentric until creep does not occur in either direction. When the wheel stops rotating, tighten the nut locking the eccentric and the adjustment (Figure 46). Verify the adjustment with the throttle in the SLOW and FAST position.

Note: If the wheel still turns when the eccentric is at the maximum adjustment, contact your Authorized Service Distributor or refer to the *Service Manual* for further adjustment.

Adjusting the Transport Speed

Obtaining the Maximum Transport Speed

The traction pedal is adjusted for maximum-transport speed at the factory, but you may need to adjust it if the pedal reaches full stroke before it contacts the pedal stop, or if you want to decrease the transport speed.

To obtain the maximum-transport speed, put the functional control lever in the TRANSPORT position and press down on the traction pedal. If the pedal contacts the stop (Figure 47) before you feel tension on the cable, perform the following adjustment procedure:

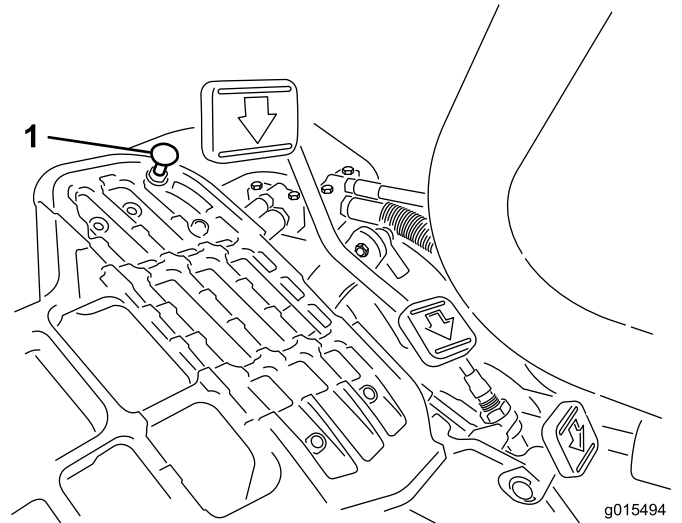

Figure 47

1. Pedal stop

1. Put the functional-control lever in the TRANSPORT position and loosen the locknut securing the pedal stop to the floor plate (Figure 47).
2. Tighten the pedal stop until it does not contact the traction pedal.
3. Continue applying a light load on the transport pedal and adjust the pedal stop so it contacts the pedal rod and tighten the nuts.

Important: Ensure that the tension on the cable is not excessive or you will reduce the cable life.

Reducing the Transport Speed

1. Press down on the traction pedal and loosen the locknut securing the pedal stop to the floor plate.
2. Loosen the pedal stop until you obtain the desired transport speed.
3. Tighten the locknut securing the pedal stop.

Adjusting the Mowing Speed

The mow speed is set to 3.8 mph at the factory.

The forward moving speed can be adjusted from 0 to 8 km/h (0 to 5 mph).

1. Loosen the jam nut on the trunnion bolt (Figure 48).
2. Loosen the nut securing the lock and mow brackets on the pedal pivot.

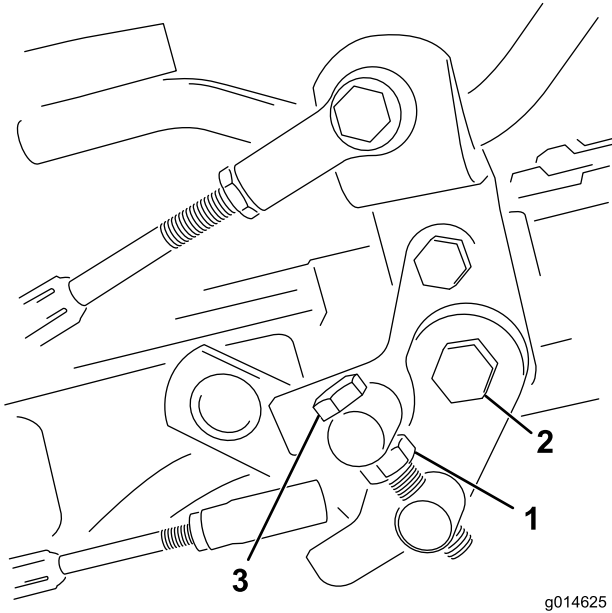

Figure 48

1. Jam nut
2. Nut
3. Trunnion bolt

3. Rotate the trunnion bolt clockwise to reduce the mowing speed and counterclockwise to increase the mowing speed.
4. Tighten the jam nut on the trunnion bolt and the nut on the pedal pivot to lock the adjustment (Figure 48). Check the adjustment and adjust as required.

Brake Maintenance

Adjusting the Brakes

If the brake fails to hold the machine while parked, you can adjust the brakes using the bulkhead fitting near the brake drum; contact your Authorized Service Distributor or refer to the *Service Manual* for more information.

Note: Burnish the brakes annually; refer to [Breaking in the Machine \(page 23\)](#).

Hydraulic System Maintenance

Changing the Hydraulic Fluid and Filter

Service Interval: After the first 50 hours

Every 800 hours

If the oil becomes contaminated, have your Toro distributor flush the system. Contaminated oil looks milky or black when compared to clean oil.

1. Clean the area around the filter mounting area ([Figure 49](#)). Place a drain pan under the filter and remove the filter.

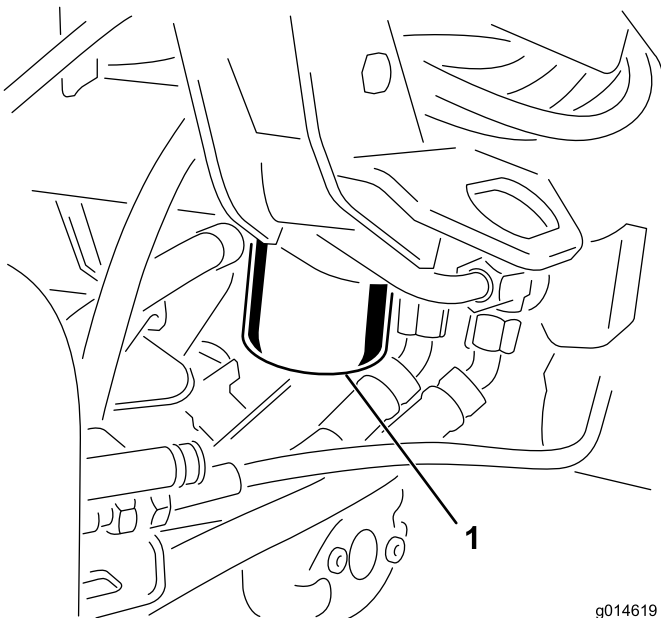

Figure 49

1. Hydraulic-oil filter

Note: If you will not be draining the oil, disconnect and plug the hydraulic line going to the filter.

2. Fill the replacement filter with the appropriate hydraulic fluid, lubricate the sealing gasket, and hand turn it until the gasket contacts the filter head. Then tighten it 3/4 turn further.
3. Fill the hydraulic reservoir with hydraulic fluid; refer to [Filling the Hydraulic Tank \(page 22\)](#).
4. Start the machine and run it at idle for 3 to 5 minutes to circulate the fluid and remove any air trapped in the system. Shut off the engine and check the fluid level.
5. Dispose of the oil and filter properly.

Checking the Hydraulic Lines and Hoses

⚠ WARNING

Hydraulic fluid escaping under pressure can penetrate skin and cause injury.

- Ensure that all hydraulic fluid hoses and lines are in good condition and all hydraulic connections and fittings are tight before applying pressure to the hydraulic system.
- Keep your body and hands away from pin-hole leaks or nozzles that eject high-pressure hydraulic fluid.
- Use cardboard or paper to find hydraulic leaks.
- Safely relieve all pressure in the hydraulic system before performing any work on the hydraulic system.
- Get immediate medical help if fluid is injected into skin.

Check the hydraulic lines and hoses daily for leaks, kinked lines, loose mounting supports, wear, loose fittings, weather deterioration, and chemical deterioration. Make all necessary repairs before operating.

Cutting Unit Maintenance

Backlapping the Reels

⚠ WARNING

Contact with the reels or other moving parts can result in personal injury.

- Keep fingers, hands, and clothing away from the reels or other moving parts.
- Never attempt to turn the reels by hand or foot while the engine is running.

1. Position the machine on a level surface, lower the cutting units, stop the engine, and engage the parking brake.
2. Remove the plastic cover to the left side of the seat.
3. Make initial reel to bedknife adjustments appropriate for backlapping on all cutting units which are to be backlapped; refer to the Cutting Unit *Operator's Manual*.

⚠ DANGER

Changing the engine speed while backlapping may cause the reels to stall.

- Never change the engine speed while backlapping.
 - Only backlap at idle engine speed.
4. Start the engine and run at low idle speed.
 5. Rotate the backlap lever to the REVERSE (R) position (Figure 50).

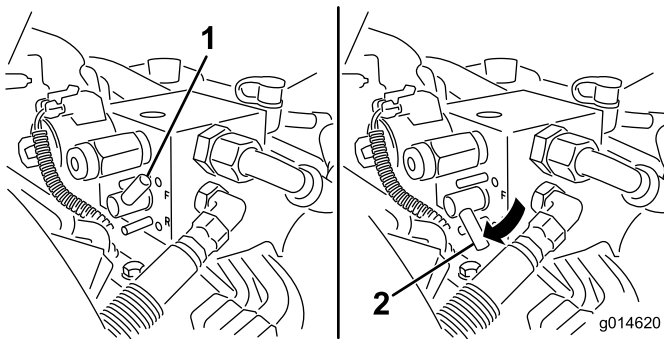

Figure 50

1. Backlap lever—FORWARD position
2. Backlap lever—REVERSE position

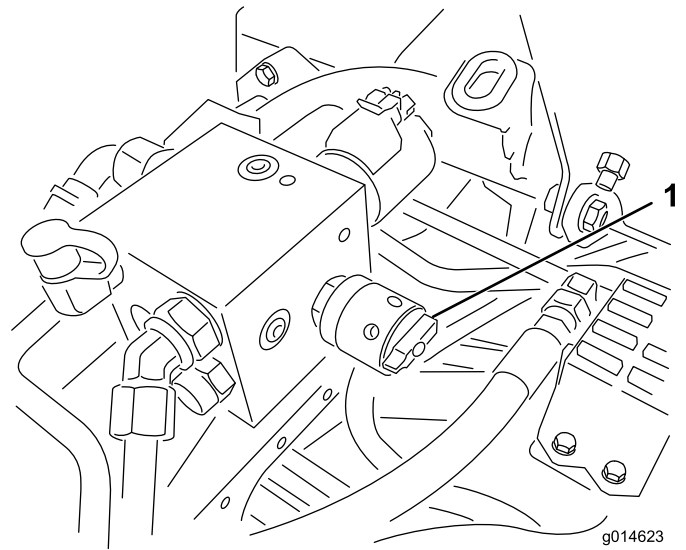

Figure 51

1. Reel-speed control

7. With the functional-control lever in the NEUTRAL position, move the raise/lower mow control forward to start the backlapping operation on the designated reels.
8. Apply lapping compound with a long handle brush. Never use a short handled brush.
9. If the reels stall or become erratic while backlapping, select a higher reel speed setting until the speed stabilizes, then return the reel speed to setting 1 or to your desired speed.
10. To make an adjustment to the cutting units while backlapping, turn the reels off by moving the raise/lower mow control rearward and stop the engine. After completing adjustments, repeat steps 4 through 8.
11. Repeat the procedure for all cutting units you want to backlap.
12. When finished, return the backlap levers to the FORWARD (F) position, replace the cover, and wash all lapping compound off of the cutting units. Adjust cutting unit reel to bedknife as needed. Move the cutting unit reel speed control to the desired mowing position.

Important: If the backlap lever is not returned to the FORWARD (F) position after backlapping, the cutting units will not raise or function properly.

6. Rotate the reel-speed control to setting 1 (Figure 51).

Diagnostics System

Diagnosing the Service-Indicator Light

The service indicator light illuminates in the event of a fault in the machine. When this light is on, you can access the computer codes to diagnose the problem by entering diagnostic mode. In diagnostic mode, the service indicator light will flash a number of times giving you the error code that you or your distributor can use to identify the problem.

Note: The engine cannot be started in diagnostic mode.

Entering Diagnostic Mode

1. Stop the machine, set the parking brake, and turn the ignition key to the OFF position.
2. Move the functional-control lever to the TRANSPORT position.
3. Ensure that the backlap lever is set to the FORWARD (F) position.
4. Get off of the seat.
5. Hold the raise/lower mow control in the RAISED position.
6. Turn the ignition switch to the RUN position.
7. Count the codes as they begin to flash (you may release the raise/lower mow control once they begin flashing).

When finished, turn the key to the OFF position to exit diagnostic mode.

Determining the Error Code

The system will display the last 3 faults that occurred in the last 40 hours. It displays the faults through a series of blinking lights, as follows:

- If there are no faults, the light will blink steadily at a medium rate without pauses (1 Hz).
- If there is a fault, it will first blink the tens place, followed by a pause, followed by the ones place. For the following examples, a # represents a blink. Examples:
 - If the code is 15, the blink pattern will be #_#####
 - If the code is 42, the blink pattern will be #####_##
 - If the code is 123, the blink pattern will be #####_###
- If there are more than one fault, the tens place of the next fault will begin after a pause after the ones place of the first fault.

Note: The system stores only the three most recent fault codes.

For a list of error codes, refer to your Authorized Distributor or the *Service Manual*.

Storage

If you wish to store the machine for a long period of time, the following steps should be performed prior to storage:

1. Remove accumulations of dirt and old grass clippings. Sharpen the reels and bedknives, if necessary; refer to the cutting unit *Operator's Manual*. Use a rust preventive on bedknives and reel blades. Grease and oil all lubrication points.
2. Block up the wheels to remove any weight on the tires.
3. Drain and replace the hydraulic fluid and filter and inspect the hydraulic lines and fittings. Replace, if necessary; refer to [Changing the Hydraulic Fluid and Filter \(page 39\)](#) and [Checking the Hydraulic Lines and Hoses \(page 39\)](#).
4. All fuel should be removed from the fuel tank. Run the engine until it stops from lack of fuel. Replace the fuel filter; refer to [Replacing the Fuel Filter \(page 35\)](#).
5. While the engine is still warm, drain the oil from the crankcase. Refill it with fresh oil; refer to [Changing the Engine Oil and Filter \(page 34\)](#).
6. Remove the spark plugs, pour one ounce of SAE 30 oil into the cylinders, and crank slowly to distribute the oil. Replace the spark plugs; refer to [Replacing the Spark Plugs \(page 35\)](#).
7. Clean dirt and chaff from the cylinder, cylinder head fins, and blower housing.
8. Remove the battery and charge it fully. Either store it on the shelf or on the machine. Leave the cables disconnected if it is stored on the machine. Store the battery in a cool atmosphere to avoid quick deterioration of the charge in the battery.
9. If possible, store the machine in a warm, dry location.

Notes:

International Distributor List

Distributor:	Country:	Phone Number:	Distributor:	Country:	Phone Number:
Agrolanc Kft	Hungary	36 27 539 640	Maquiver S.A.	Colombia	57 1 236 4079
Asian American Industrial (AAI)	Hong Kong	852 2497 7804	Maruyama Mfg. Co. Inc.	Japan	81 3 3252 2285
B-Ray Corporation	Korea	82 32 551 2076	Mountfield a.s.	Czech Republic	420 255 704 220
Brisa Goods LLC	Mexico	1 210 495 2417	Mountfield a.s.	Slovakia	420 255 704 220
Casco Sales Company	Puerto Rico	787 788 8383	Munditol S.A.	Argentina	54 11 4 821 9999
Ceres S.A.	Costa Rica	506 239 1138	Norma Garden	Russia	7 495 411 61 20
CSSC Turf Equipment (pvt) Ltd.	Sri Lanka	94 11 2746100	Oslinger Turf Equipment SA	Ecuador	593 4 239 6970
Cyril Johnston & Co.	Northern Ireland	44 2890 813 121	Oy Hako Ground and Garden Ab	Finland	358 987 00733
Cyril Johnston & Co.	Republic of Ireland	44 2890 813 121	Parkland Products Ltd.	New Zealand	64 3 34 93760
Fat Dragon	China	886 10 80841322	Perfetto	Poland	48 61 8 208 416
Femco S.A.	Guatemala	502 442 3277	Pratoverde SRL.	Italy	39 049 9128 128
FIVEMANS New-Tech Co., Ltd	China	86-10-6381 6136	Prochaska & Cie	Austria	43 1 278 5100
ForGarder OU	Estonia	372 384 6060	RT Cohen 2004 Ltd.	Israel	972 986 17979
G.Y.K. Company Ltd.	Japan	81 726 325 861	Riversa	Spain	34 9 52 83 7500
Geomechaniki of Athens	Greece	30 10 935 0054	Lely Turfcare	Denmark	45 66 109 200
Golf international Turizm	Turkey	90 216 336 5993	Lely (U.K.) Limited	United Kingdom	44 1480 226 800
Hako Ground and Garden	Sweden	46 35 10 0000	Solvart S.A.S.	France	33 1 30 81 77 00
Hako Ground and Garden	Norway	47 22 90 7760	Spypros Stavrinides Limited	Cyprus	357 22 434131
Hayter Limited (U.K.)	United Kingdom	44 1279 723 444	Surge Systems India Limited	India	91 1 292299901
Hydroturf Int. Co Dubai	United Arab Emirates	97 14 347 9479	T-Markt Logistics Ltd.	Hungary	36 26 525 500
Hydroturf Egypt LLC	Egypt	202 519 4308	Toro Australia	Australia	61 3 9580 7355
Irrimac	Portugal	351 21 238 8260	Toro Europe NV	Belgium	32 14 562 960
Irrigation Products Int'l Pvt Ltd.	India	0091 44 2449 4387	Valtech	Morocco	212 5 3766 3636
Jean Heybroek b.v.	Netherlands	31 30 639 4611	Victus Emak	Poland	48 61 823 8369

European Privacy Notice

The Information Toro Collects

Toro Warranty Company (Toro) respects your privacy. In order to process your warranty claim and contact you in the event of a product recall, we ask you to share certain personal information with us, either directly or through your local Toro company or dealer.

The Toro warranty system is hosted on servers located within the United States where privacy law may not provide the same protection as applies in your country.

BY SHARING YOUR PERSONAL INFORMATION WITH US, YOU ARE CONSENTING TO THE PROCESSING OF YOUR PERSONAL INFORMATION AS DESCRIBED IN THIS PRIVACY NOTICE.

The Way Toro Uses Information

Toro may use your personal information to process warranty claims, to contact you in the event of a product recall and for any other purpose which we tell you about. Toro may share your information with Toro's affiliates, dealers or other business partners in connection with any of these activities. We will not sell your personal information to any other company. We reserve the right to disclose personal information in order to comply with applicable laws and with requests by the appropriate authorities, to operate our systems properly or for our own protection or that of other users.

Retention of your Personal Information

We will keep your personal information as long as we need it for the purposes for which it was originally collected or for other legitimate purposes (such as regulatory compliance), or as required by applicable law.

Toro's Commitment to Security of Your Personal Information

We take reasonable precautions in order to protect the security of your personal information. We also take steps to maintain the accuracy and current status of personal information.

Access and Correction of your Personal Information

If you would like to review or correct your personal information, please contact us by email at legal@toro.com.

Australian Consumer Law

Australian customers will find details relating to the Australian Consumer Law either inside the box or at your local Toro Dealer.



The Toro Warranty

A Two-Year Limited Warranty

Conditions and Products Covered

The Toro Company and its affiliate, Toro Warranty Company, pursuant to an agreement between them, jointly warrant your Toro Commercial product ("Product") to be free from defects in materials or workmanship for two years or 1500 operational hours*, whichever occurs first. This warranty is applicable to all products with the exception of Aerators (refer to separate warranty statements for these products). Where a warrantable condition exists, we will repair the Product at no cost to you including diagnostics, labor, parts, and transportation. This warranty begins on the date the Product is delivered to the original retail purchaser.

* Product equipped with an hour meter.

Instructions for Obtaining Warranty Service

You are responsible for notifying the Commercial Products Distributor or Authorized Commercial Products Dealer from whom you purchased the Product as soon as you believe a warrantable condition exists. If you need help locating a Commercial Products Distributor or Authorized Dealer, or if you have questions regarding your warranty rights or responsibilities, you may contact us at:

Toro Commercial Products Service Department
Toro Warranty Company
8111 Lyndale Avenue South
Bloomington, MN 55420-1196
952-888-8801 or 800-952-2740
E-mail: commercial.warranty@toro.com

Owner Responsibilities

As the Product owner, you are responsible for required maintenance and adjustments stated in your *Operator's Manual*. Failure to perform required maintenance and adjustments can be grounds for disallowing a warranty claim.

Items and Conditions Not Covered

Not all product failures or malfunctions that occur during the warranty period are defects in materials or workmanship. This warranty does not cover the following:

- Product failures which result from the use of non-Toro replacement parts, or from installation and use of add-on, or modified non-Toro branded accessories and products. A separate warranty may be provided by the manufacturer of these items.
- Product failures which result from failure to perform recommended maintenance and/or adjustments. Failure to properly maintain your Toro product per the Recommended Maintenance listed in the *Operator's Manual* can result in claims for warranty being denied.
- Product failures which result from operating the Product in an abusive, negligent, or reckless manner.
- Parts subject to consumption through use unless found to be defective. Examples of parts which are consumed, or used up, during normal Product operation include, but are not limited to, brake pads and linings, clutch linings, blades, reels, rollers and bearings (sealed or greasable), bed knives, spark plugs, castor wheels and bearings, tires, filters, belts, and certain sprayer components such as diaphragms, nozzles, and check valves, etc.
- Failures caused by outside influence. Conditions considered to be outside influence include, but are not limited to, weather, storage practices, contamination, use of unapproved fuels, coolants, lubricants, additives, fertilizers, water, or chemicals, etc.
- Failure or performance issues due to the use of fuels (e.g. gasoline, diesel, or biodiesel) that do not conform to their respective industry standards.

Countries Other than the United States or Canada

Customers who have purchased Toro products exported from the United States or Canada should contact their Toro Distributor (Dealer) to obtain guarantee policies for your country, province, or state. If for any reason you are dissatisfied with your Distributor's service or have difficulty obtaining guarantee information, contact the Toro importer.

- Normal noise, vibration, wear and tear, and deterioration.
- Normal "wear and tear" includes, but is not limited to, damage to seats due to wear or abrasion, worn painted surfaces, scratched decals or windows, etc.

Parts

Parts scheduled for replacement as required maintenance are warranted for the period of time up to the scheduled replacement time for that part. Parts replaced under this warranty are covered for the duration of the original product warranty and become the property of Toro. Toro will make the final decision whether to repair any existing part or assembly or replace it. Toro may use remanufactured parts for warranty repairs.

Deep Cycle and Lithium-Ion Battery Warranty:

Deep cycle and Lithium-Ion batteries have a specified total number of kilowatt-hours they can deliver during their lifetime. Operating, recharging, and maintenance techniques can extend or reduce total battery life. As the batteries in this product are consumed, the amount of useful work between charging intervals will slowly decrease until the battery is completely worn out. Replacement of worn out batteries, due to normal consumption, is the responsibility of the product owner. Battery replacement may be required during the normal product warranty period at owner's expense. Note: (Lithium-Ion battery only): A Lithium-Ion battery has a part only prorated warranty beginning year 3 through year 5 based on the time in service and kilowatt hours used. Refer to the *Operator's Manual* for additional information.

Maintenance is at Owner's Expense

Engine tune-up, lubrication, cleaning and polishing, replacement of filters, coolant, and completing recommended maintenance are some of the normal services Toro products require that are at the owner's expense.

General Conditions

Repair by an Authorized Toro Distributor or Dealer is your sole remedy under this warranty.

Neither The Toro Company nor Toro Warranty Company is liable for indirect, incidental or consequential damages in connection with the use of the Toro Products covered by this warranty, including any cost or expense of providing substitute equipment or service during reasonable periods of malfunction or non-use pending completion of repairs under this warranty. Except for the Emissions warranty referenced below, if applicable, there is no other express warranty. All implied warranties of merchantability and fitness for use are limited to the duration of this express warranty.

Some states do not allow exclusions of incidental or consequential damages, or limitations on how long an implied warranty lasts, so the above exclusions and limitations may not apply to you. This warranty gives you specific legal rights, and you may also have other rights which vary from state to state.

Note regarding engine warranty:

The Emissions Control System on your Product may be covered by a separate warranty meeting requirements established by the U.S. Environmental Protection Agency (EPA) and/or the California Air Resources Board (CARB). The hour limitations set forth above do not apply to the Emissions Control System Warranty. Refer to the Engine Emission Control Warranty Statement supplied with your product or contained in the engine manufacturer's documentation for details.