

WSM

WORKSHOP MANUAL
DIESEL ENGINE

SM-E4B SERIES

Kubota

TO THE READER

This Workshop Manual tells the servicing personnel about the mechanism, servicing and maintenance of SM-E4B series. It contains 4 parts: "**Information**", "**General**", "**Mechanism**" and "**Servicing**".

■ **Information**

This section primarily contains information below.

- Safety First
- Specification
- Performance Curve
- Dimension

■ **General**

This section primarily contains information below.

- Engine Identification
- General Precautions
- Maintenance Check List
- Check and Maintenance
- Special Tools

■ **Mechanism**

This section contains information on the structure and the function of the unit. Before you continue with the subsequent sections, make sure that you read this section.

Refer to the latest version of Workshop Manual (Code No. 9Y021-01870 / 9Y021-18200) for the diesel engine / tractor mechanism that this workshop manual does not include.

■ **Servicing**

This section primarily contains information below.

- Troubleshooting
- Servicing Specifications
- Tightening Torques
- Checking, Disassembling and Servicing

All illustrations, photographs and specifications contained in this manual are of the newest information available at the time of publication.

KUBOTA reserves the right to change all information at any time without notice.

Since this manual includes many models, information or illustrations and photographs can show more than one model.

December, 2012

© KUBOTA Corporation 2012

I INFORMATION

INFORMATION

CONTENTS

- 1. SAFETY FIRST I-1
- 2. SPECIFICATIONS I-4
- 3. PERFORMANCE CURVES I-6
- 4. DIMENSIONS I-11

1. SAFETY FIRST

SAFETY FIRST

- This symbol, the industry's "Safety Alert Symbol", is used throughout this manual and on labels on the machine itself to warn of the possibility of personal injury. Read these instructions carefully.
- It is essential that you read the instructions and safety regulations before you try to repair or use this unit.

DANGER

- Indicates an imminently hazardous situation which, if not avoided, will result in death or serious injury.

WARNING

- Indicates a potentially hazardous situation which, if not avoided, could result in death or serious injury.

CAUTION

- Indicates a potentially hazardous situation which, if not avoided, may result in minor or moderate injury.

■ IMPORTANT

- Indicates that equipment or property damage could result if instructions are not followed.

■ NOTE

- Gives helpful information.

WSM000001INI0001US1

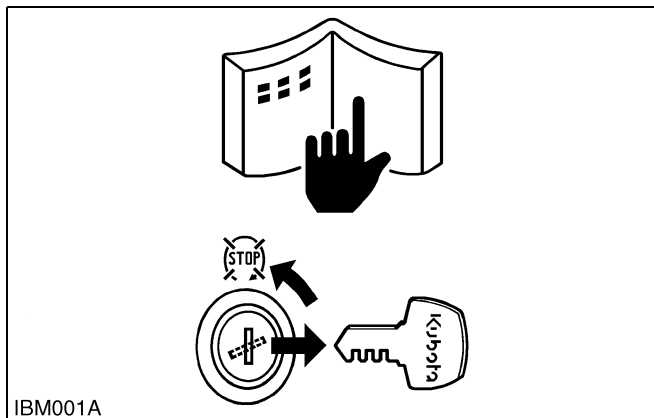

BEFORE YOU START SERVICE

- Read all instructions and safety instructions in this manual and on your engine safety decals.
- Clean the work area and engine.
- Park the machine on a stable and level ground.
- Let the temperature of the engine decrease before you start a job.
- Stop the engine, then remove the key.
- Disconnect the battery negative cable.
- Hang a "**DO NOT OPERATE**" tag in the operator station.

WSM000001INI0002US0



START SAFELY

- Do not do the procedures below when you start the engine.
 - short across starter terminals
 - bypass the safety start switch
- Do not make unauthorized modifications to the engine. This can cause damage and decrease the engine life.

WSM000001INI0003US0

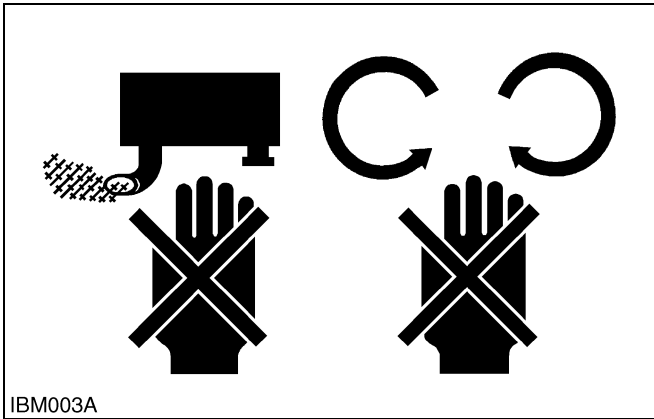

IBM003A

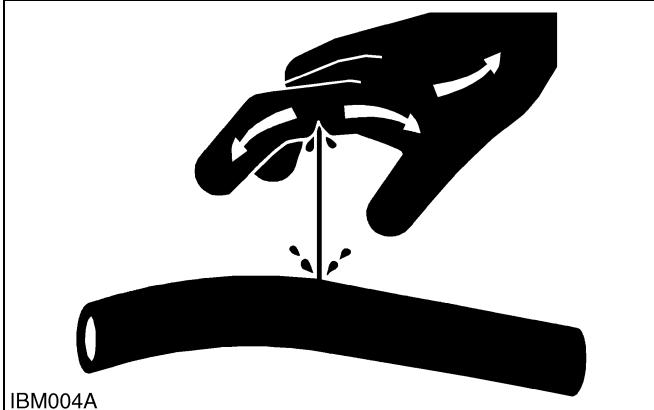

IBM004A

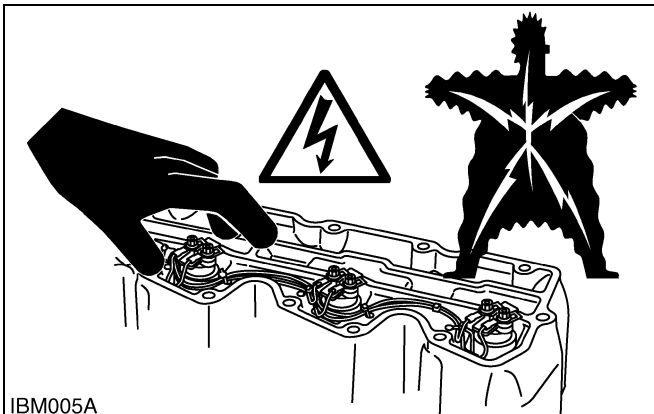

IBM005A

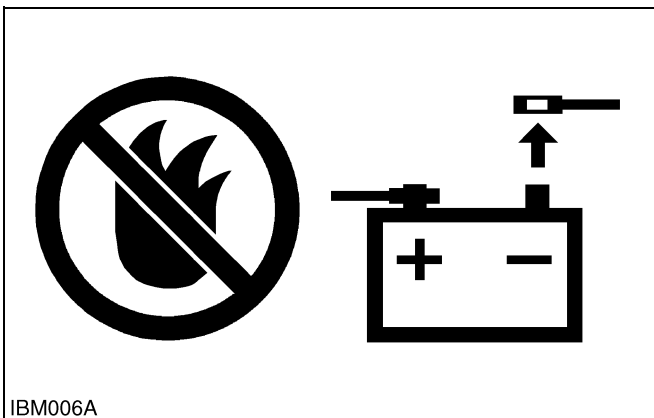

IBM006A

OPERATE SAFELY

- Do not use the machine after you consume alcohol or medication or when you are tired.
- Put on applicable clothing and safety equipment.
- Use applicable tools only. Do not use alternative tools or parts.
- When 2 or more persons do servicing, make sure that you do it safely.
- Do not touch the hot parts or parts that turn when the engine operates.
- Do not remove the radiator cap when the engine operates, or immediately after it stops. If not, hot water can spout out from the radiator. Only remove the radiator cap when it is at a sufficiently low temperature to touch with bare hands. Slowly loosen the cap to release the pressure before you remove it fully.
- Released fluid (fuel or hydraulic oil) under pressure can cause damage to the skin and cause serious injury. Release the pressure before you disconnect hydraulic or fuel lines. Tighten all connections before you apply the pressure.
- Do not open a fuel system under high pressure. The fluid under high pressure that stays in fuel lines can cause serious injury. Do not disconnect or repair the fuel lines, sensors, or any other components between the fuel pump and injectors on engines with a common rail fuel system under high pressure.
- Put on an applicable ear protective device (earmuffs or earplugs) to prevent injury against loud noises.
- Be careful about electric shock. The engine generates a high voltage of more than DC100 V in the ECU and is applied to the injector.

WSM000001INI0004US0

PREVENT A FIRE

- Fuel is very flammable and explosive under some conditions. Do not smoke or let flames or sparks in your work area.
- To prevent sparks from an accidental short circuit, always disconnect the battery negative cable first and connect it last.
- The battery gas can cause an explosion. Keep the sparks and open flame away from the top of battery, especially when you charge the battery.
- Make sure that you do not spill fuel on the engine.

WSM000001INI0005US1

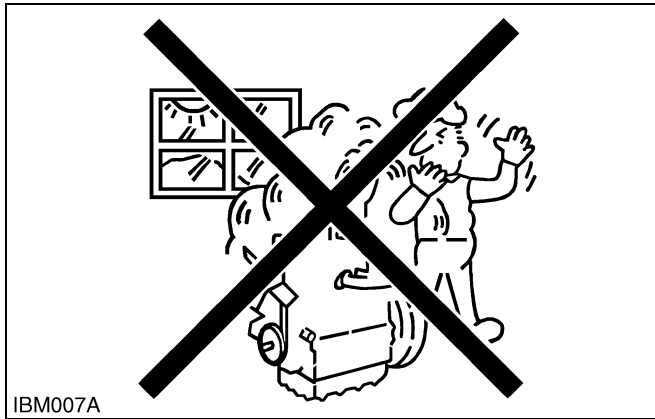

IBM007A

KEEP A GOOD AIRFLOW IN THE WORK AREA

- If the engine is in operation, make sure that the area has good airflow. Do not operate the engine in a closed area. The exhaust gas contains poisonous carbon monoxide.

WSM000001INI0006US1

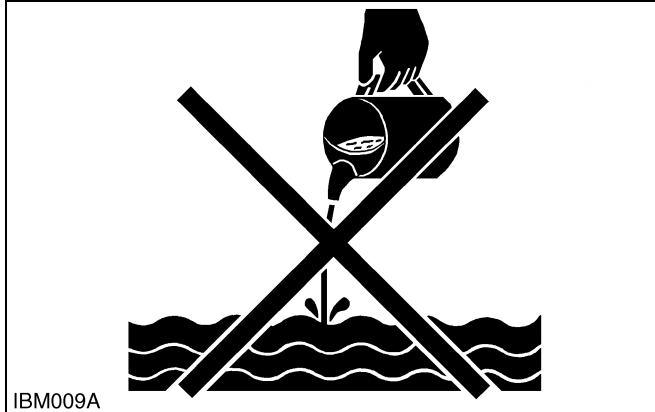

IBM009A

DISCARD FLUIDS CORRECTLY

- Do not discard fluids on the ground, down the drain, into a stream, pond, or lake. Obey related environmental protection regulations when you discard oil, fuel, coolant, electrolyte and other dangerous waste.

WSM000001INI0007US1

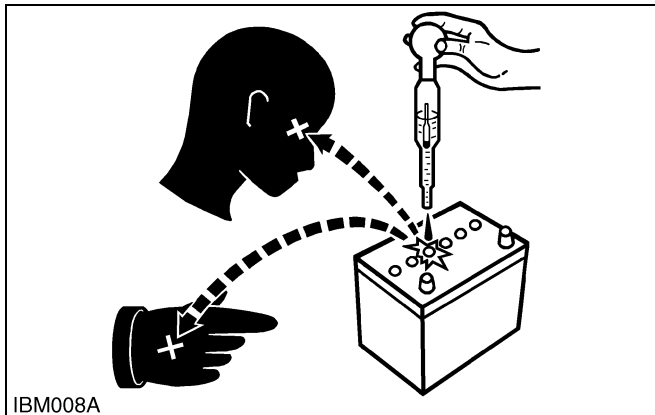

IBM008A

PREVENT ACID BURNS

- Keep electrolyte away from your eyes, hands and clothing. Sulfuric acid in battery electrolyte is poisonous and it can burn your skin and clothing and cause blindness. If you spill electrolyte on yourself, clean yourself with water, and get medical aid immediately.

WSM000001INI0008US1

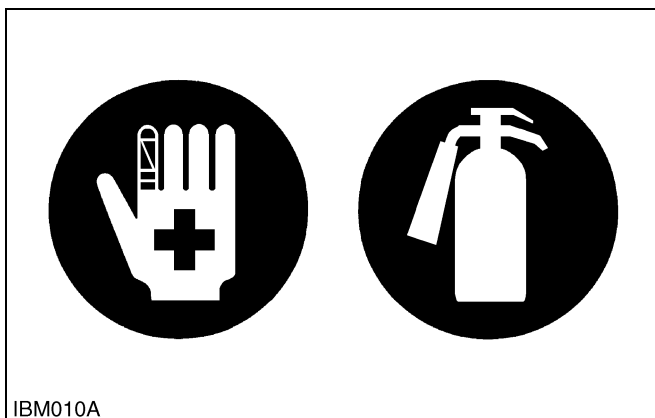

IBM010A

PREPARE FOR EMERGENCIES

- Keep a first aid kit and fire extinguisher ready at all times.
- Keep the emergency contact telephone numbers near your telephone at all times.

WSM000001INI0009US1

2. SPECIFICATIONS

Model	Z482-E4B	Z602-E4B	
Number of Cylinder	2		
Type	Vertical, Water-cooled, 4 cycle IDI diesel engine		
Bore × Stroke	67.0 × 68.0 mm (2.64 × 2.68 in.)	72.0 × 73.6 mm (2.83 × 2.90 in.)	
Total Displacement	479.0 cm ³ (29.23 cu.in.)	599.0 cm ³ (36.55 cu.in.)	
ISO Net Continuous	8.10 kW / 3600 min ⁻¹ (rpm) (10.9 HP / 3600 min ⁻¹ (rpm))	10.1 kW / 3600 min ⁻¹ (rpm) (13.5 HP / 3600 min ⁻¹ (rpm))	
ISO / SAE Net Intermittent	9.30 kW / 3600 min ⁻¹ (rpm) (12.5 HP / 3600 min ⁻¹ (rpm))	11.6 kW / 3600 min ⁻¹ (rpm) (15.5 HP / 3600 min ⁻¹ (rpm))	
SAE Gross Intermittent	9.90 kW / 3600 min ⁻¹ (rpm) (13.3 HP / 3600 min ⁻¹ (rpm))	12.5 kW / 3600 min ⁻¹ (rpm) (16.8 HP / 3600 min ⁻¹ (rpm))	
Maximum Bare Speed	3800 min ⁻¹ (rpm)	3850 min ⁻¹ (rpm)	
Minimum Bare Idling Speed	1250 to 1350 min ⁻¹ (rpm)	1050 to 1150 min ⁻¹ (rpm)	
Combustion Chamber	Spherical type (E-TVCS)		
Fuel Injection Pump	Bosch MD type mini pump		
Governor	All speed mechanical governor		
Direction of Rotation	Counter-clockwise (viewed from flywheel side)		
Injection Nozzle	Bosch "Throttle" type		
Injection Timing	0.33 rad (19 °) before T.D.C.		
Firing Order	1-2		
Injection Pressure	13.73 MPa (140.0 kgf/cm ² , 1991 psi)		
Compression Ratio	23.5 : 1	24 : 1	
Lubricating System	Forced lubrication by trochoid pump		
Oil Pressure Indicating	Electrical type switch		
Lubricating Filter	Full flow paper filter (Cartridge type)		
Cooling System	Pressurized radiator, forced circulation with water pump (not included in the basic engine)		
Starting System	Electric Starting with Starter		
Starting Motor	12 V, 0.8 kW	12 V, 1.0 kW	
Starting Support Device	By glow plug in combustion chamber		
EGR	None		
Battery	12 V, 28 AH equivalent	12 V, 36 AH equivalent	
Charging Alternator	12 V, 150 W	12 V, 480 W	
Fuel	Diesel Fuel No.2-D (ASTM D975)		
Lubricating Oil	Class CF lubricating oil as per API classification is recommended. For details on recommended lubricating oils, see page G-6		
Lubricating Oil Capacity	Oil Pan Depth 101 mm (3.98 in.)	2.1 L (0.55 U.S.gals)	2.5 L (0.66 U.S.gals)
	Oil Pan Depth 121 mm (4.76 in.)	2.5 L (0.66 U.S.gals)	-
Weight (Dry)	53.1 kg (117 lbs)	57.0 kg (125.7 lbs)	

*The specification described above is of the standard engine of each model.

*Conversion Formula : HP = 0.746 kW, PS = 0.7355 kW

Model	D722-E4B	D782-E4B	D902-E4B	
Number of Cylinder	3			
Type	Vertical, Water-cooled, 4 cycle IDI diesel engine			
Bore × Stroke	67.0 × 68.0 mm (2.64 × 2.68 in.)	67.0 × 73.6 mm (2.64 × 2.90 in.)	72.0 × 73.6 mm (2.83 × 2.90 in.)	
Total Displacement	719.0 cm ³ (43.88 cu.in.)	778.0 cm ³ (47.48 cu.in.)	898.0 cm ³ (54.80 cu.in.)	
ISO Net Continuous	12.2 kW / 3600 min ⁻¹ (rpm) (16.3 HP / 3600 min ⁻¹ (rpm))	11.9 kW / 3200 min ⁻¹ (rpm) (16.0 HP / 3200 min ⁻¹ (rpm))	15.2 kW / 3600 min ⁻¹ (rpm) (20.4 HP / 3600 min ⁻¹ (rpm))	
ISO / SAE Net Intermittent	14.0 kW / 3600 min ⁻¹ (rpm) (18.8 HP / 3600 min ⁻¹ (rpm))	13.5 kW / 3200 min ⁻¹ (rpm) (18.1 HP / 3200 min ⁻¹ (rpm))	17.5 kW / 3600 min ⁻¹ (rpm) (23.5 HP / 3600 min ⁻¹ (rpm))	
SAE Gross Intermittent	14.9 kW / 3600 min ⁻¹ (rpm) (20.0 HP / 3600 min ⁻¹ (rpm))	14.4 kW / 3200 min ⁻¹ (rpm) (19.3 HP / 3200 min ⁻¹ (rpm))	18.5 kW / 3600 min ⁻¹ (rpm) (24.8 HP / 3600 min ⁻¹ (rpm))	
Maximum Bare Speed	3800 min ⁻¹ (rpm)	3450 min ⁻¹ (rpm)	3850 min ⁻¹ (rpm)	
Minimum Bare Idling Speed	1250 to 1350 min ⁻¹ (rpm)	1000 to 1100 min ⁻¹ (rpm)	900 to 1000 min ⁻¹ (rpm)	
Combustion Chamber	Spherical type (E-TVCS)			
Fuel Injection Pump	Bosch MD type mini pump			
Governor	All speed mechanical governor			
Direction of Rotation	Counter-clockwise (viewed from flywheel side)			
Injection Nozzle	Bosch "Throttle" type			
Injection Timing	0.35 rad (20 °) before T.D.C.	0.30 rad (17 °) before T.D.C.	0.331 rad (19 °) before T.D.C.	
Firing Order	1-2-3			
Injection Pressure	13.73 MPa (140.0 kgf/cm ² , 1991 psi)			
Compression Ratio	23.5 : 1	24 : 1		
Lubricating System	Forced lubrication by trochoid pump			
Oil Pressure Indicating	Electrical type switch			
Lubricating Filter	Full flow paper filter (Cartridge type)			
Cooling System	Pressurized radiator, forced circulation with water pump (not included in the basic engine)			
Starting System	Electric Starting with Starter			
Starting Motor	12 V, 1.0 kW		12 V, 1.2 kW	
Starting Support Device	By glow plug in combustion chamber			
EGR	None			
Battery	12 V, 36 AH equivalent		12 V, 52 AH equivalent	
Charging Alternator	12 V, 150 W		12 V, 480 W	
Fuel	Diesel Fuel No.2-D (ASTM D975)			
Lubricating Oil	Class CF lubricating oil as per API classification is recommended. For details on recommended lubricating oils, see page G-6.			
Lubricating Oil Capacity	Oil Pan Depth 101 mm (3.98 in.)	3.2 L (0.85 U.S.gals)	–	3.7 L (0.98 U.S.gals)
	Oil Pan Depth 121 mm (4.76 in.)	3.8 L (1.0 U.S.gals)	3.6 L (0.95 U.S.gals)	–
Weight (Dry)	63.1 kg (139.1 lbs)	63.5 kg (140 lbs)	72.0 kg (159 lbs)	

*The specification described above is of the standard engine of each model.

*Conversion Formula : HP = 0.746 kW, PS = 0.7355 kW

9Y1210785INI0001US0

3. PERFORMANCE CURVES

Z482-E4B

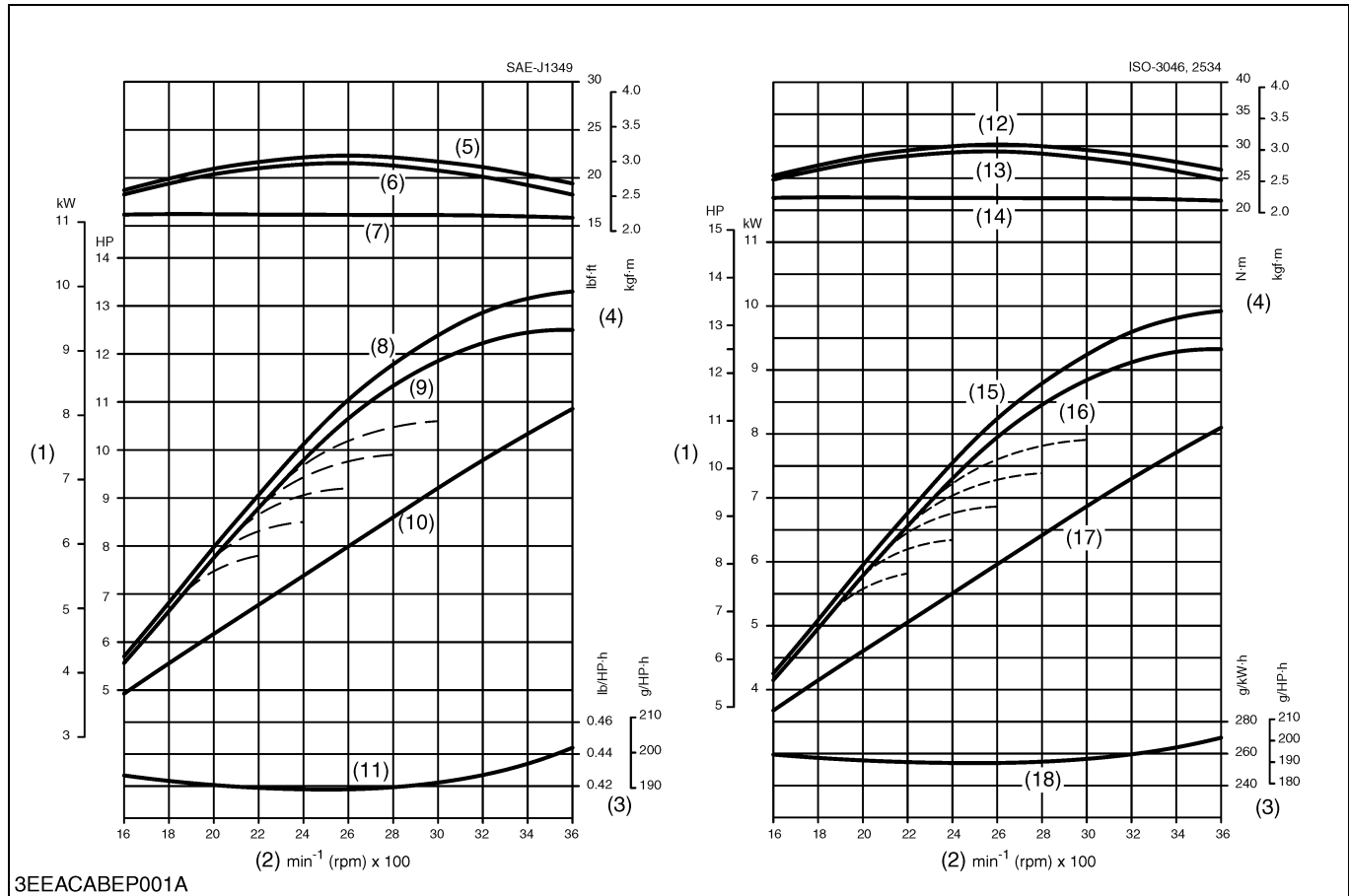

3EEACABEP001A

- | | | | |
|-------------------------------|-------------------------------|--------------------------------|------------------------|
| (1) Brake Horsepower | (6) Net Intermittent Torque | (11) Net Intermittent B.S.F.C. | (15) Gross B.H.P. |
| (2) Engine Speed | (7) Net Continuous Torque | (12) Gross Torque | (16) Overload B.H.P. |
| (3) B.S.F.C. | (8) Gross Intermittent B.H.P. | (13) Overload Torque | (17) Continuous B.H.P. |
| (4) Torque | (9) Net Intermittent B.H.P. | (14) Continuous Torque | (18) Overload B.S.F.C. |
| (5) Gross Intermittent Torque | (10) Net Continuous B.H.P. | | |

9Y1210785INI0002US0

Z602-E4B

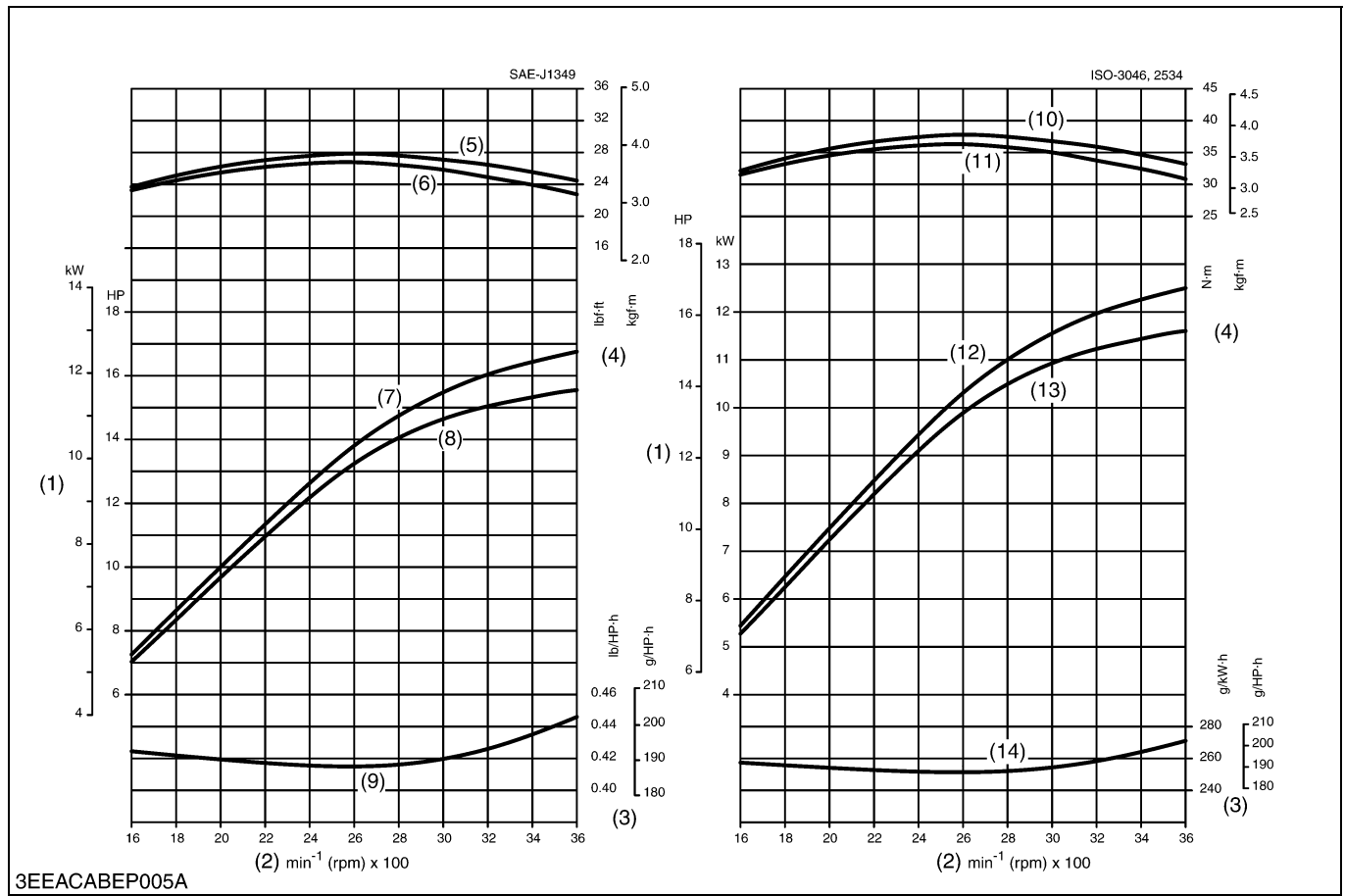

- | | | | |
|----------------------|-------------------------------|-------------------------------|------------------------|
| (1) Brake Horsepower | (5) Gross Intermittent Torque | (9) Net Intermittent B.S.F.C. | (12) Gross B.H.P. |
| (2) Engine Speed | (6) Net Intermittent Torque | (10) Gross Torque | (13) Overload B.H.P. |
| (3) B.S.F.C. | (7) Gross Intermittent B.H.P. | (11) Overload Torque | (14) Overload B.S.F.C. |
| (4) Torque | (8) Net Intermittent B.H.P. | | |

9Y1210785INI0003US0

D722-E4B

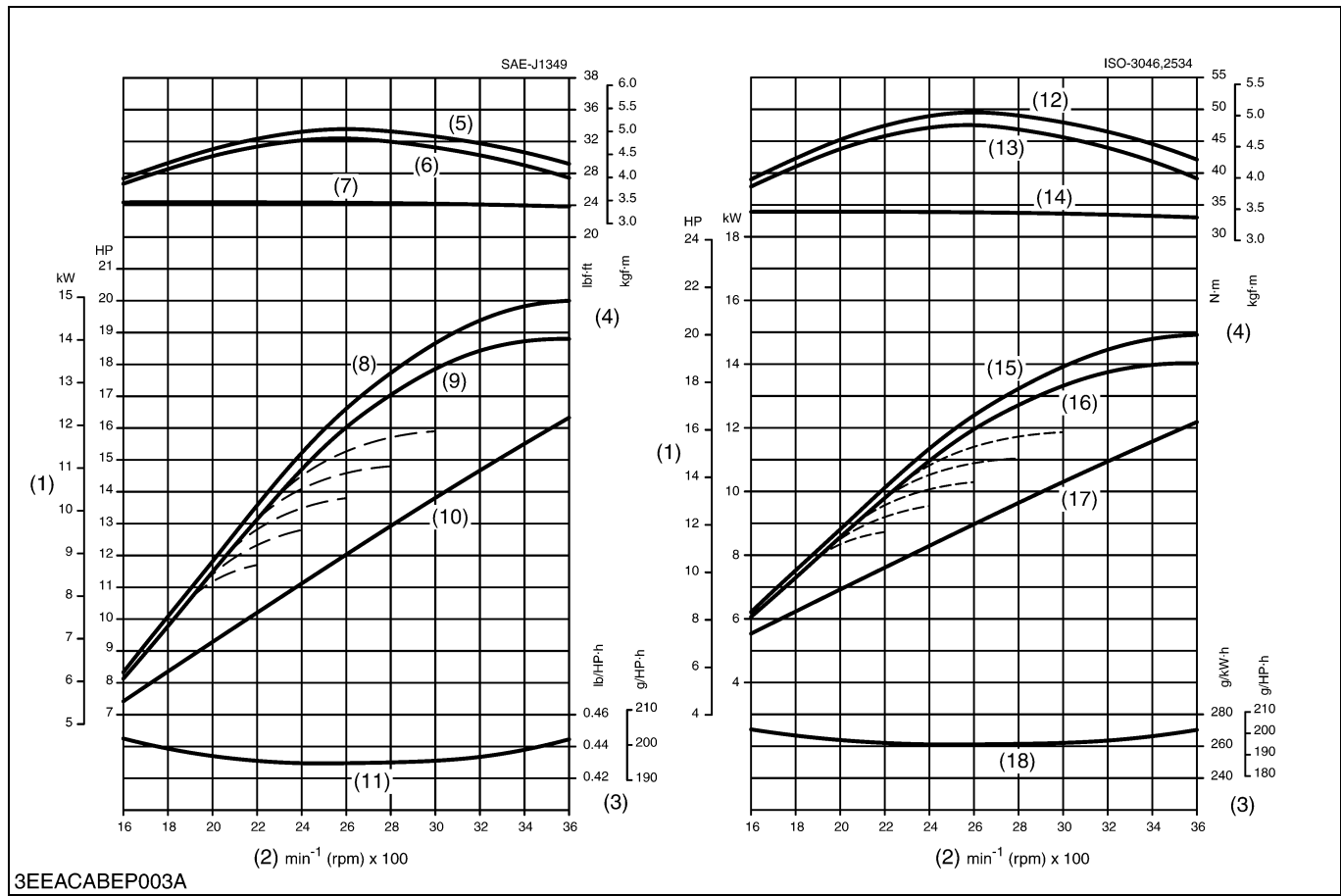

3EEACABEP003A

- | | | | |
|-------------------------------|-------------------------------|--------------------------------|------------------------|
| (1) Brake Horsepower | (6) Net Intermittent Torque | (11) Net Intermittent B.S.F.C. | (15) Gross B.H.P. |
| (2) Engine Speed | (7) Net Continuous Torque | (12) Gross Torque | (16) Overload B.H.P. |
| (3) B.S.F.C. | (8) Gross Intermittent B.H.P. | (13) Overload Torque | (17) Continuous B.H.P. |
| (4) Torque | (9) Net Intermittent B.H.P. | (14) Continuous Torque | (18) Overload B.S.F.C. |
| (5) Gross Intermittent Torque | (10) Net Continuous B.H.P. | | |

9Y1210785INI0004US0

D782-E4B

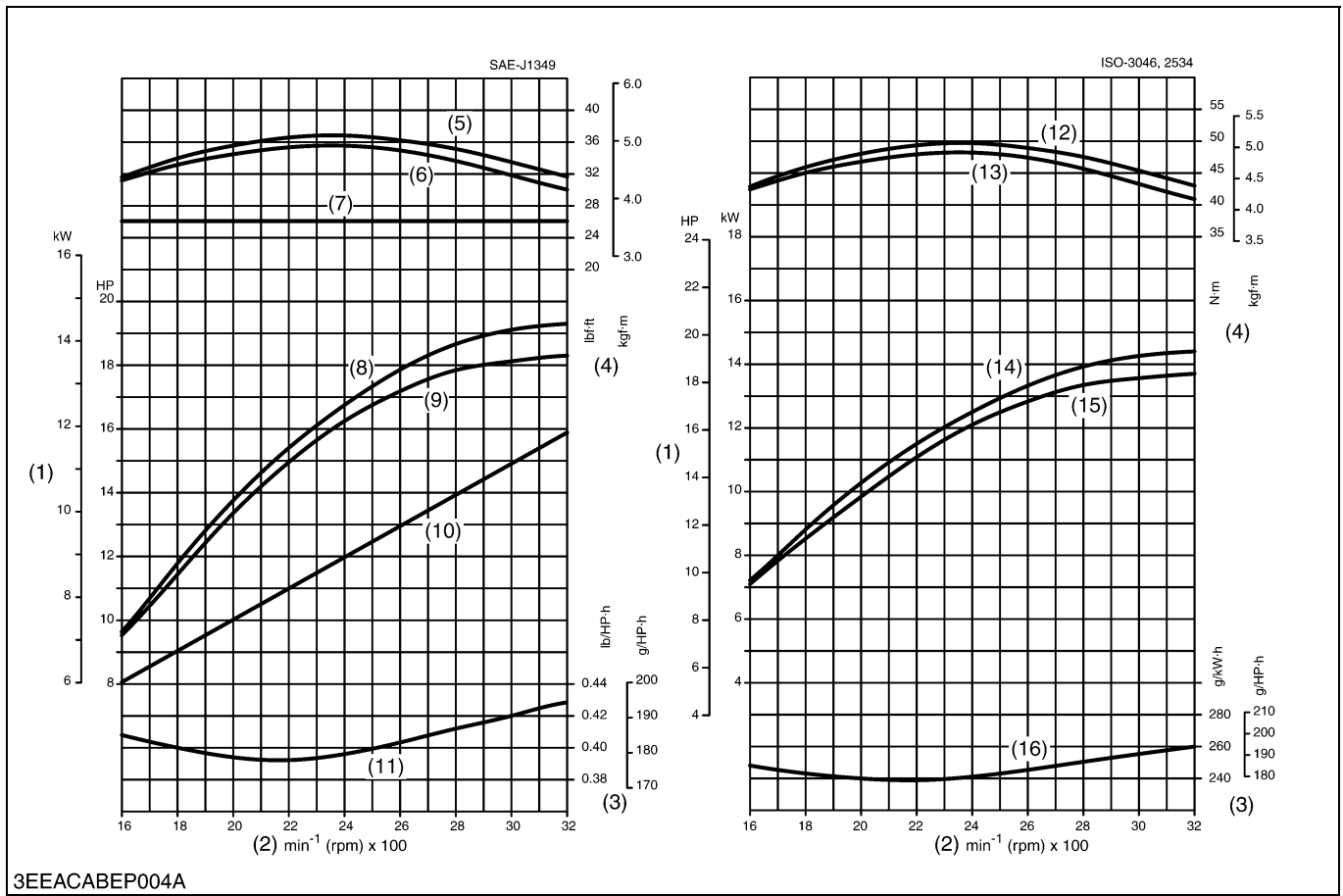

3EEACABEP004A

- | | | | |
|----------------------|-------------------------------|--------------------------------|------------------------|
| (1) Brake Horsepower | (5) Gross Intermittent Torque | (9) Net Intermittent B.H.P. | (13) Overload Torque |
| (2) Engine Speed | (6) Net Intermittent Torque | (10) Net Continuous B.H.P. | (14) Gross B.H.P. |
| (3) B.S.F.C. | (7) Net Continuous Torque | (11) Net Intermittent B.S.F.C. | (15) Overload B.H.P. |
| (4) Torque | (8) Gross Intermittent B.H.P. | (12) Gross Torque | (16) Overload B.S.F.C. |

9Y1210785INI0005US0

D902-E4B

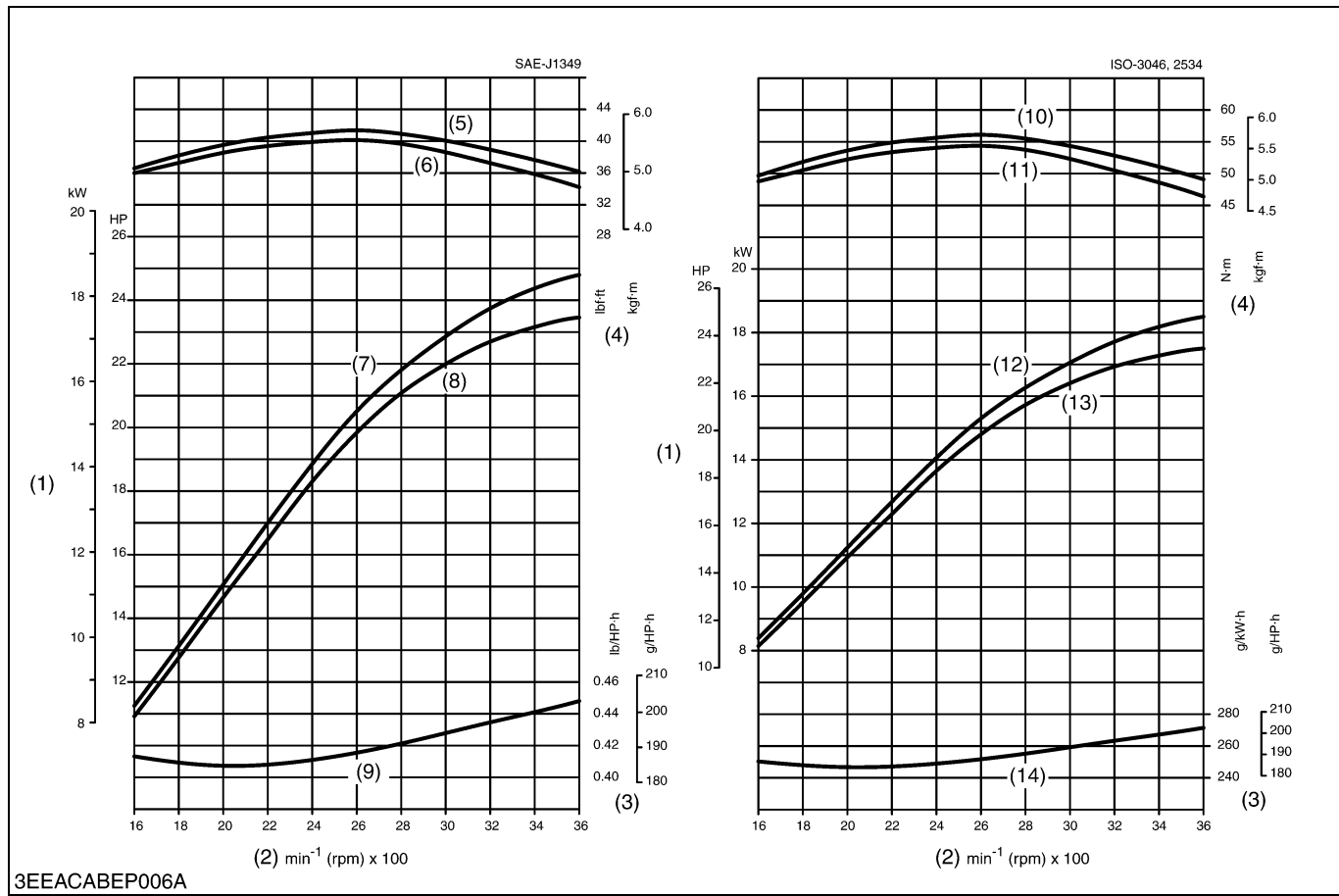

- | | | | |
|----------------------|-------------------------------|-------------------------------|------------------------|
| (1) Brake Horsepower | (5) Gross Intermittent Torque | (9) Net Intermittent B.S.F.C. | (12) Gross B.H.P. |
| (2) Engine Speed | (6) Net Intermittent Torque | (10) Gross Torque | (13) Overload B.H.P. |
| (3) B.S.F.C. | (7) Gross Intermittent B.H.P. | (11) Overload Torque | (14) Overload B.S.F.C. |
| (4) Torque | (8) Net Intermittent B.H.P. | | |

9Y1210785INI0006US0

4. DIMENSIONS

Z482-E4B

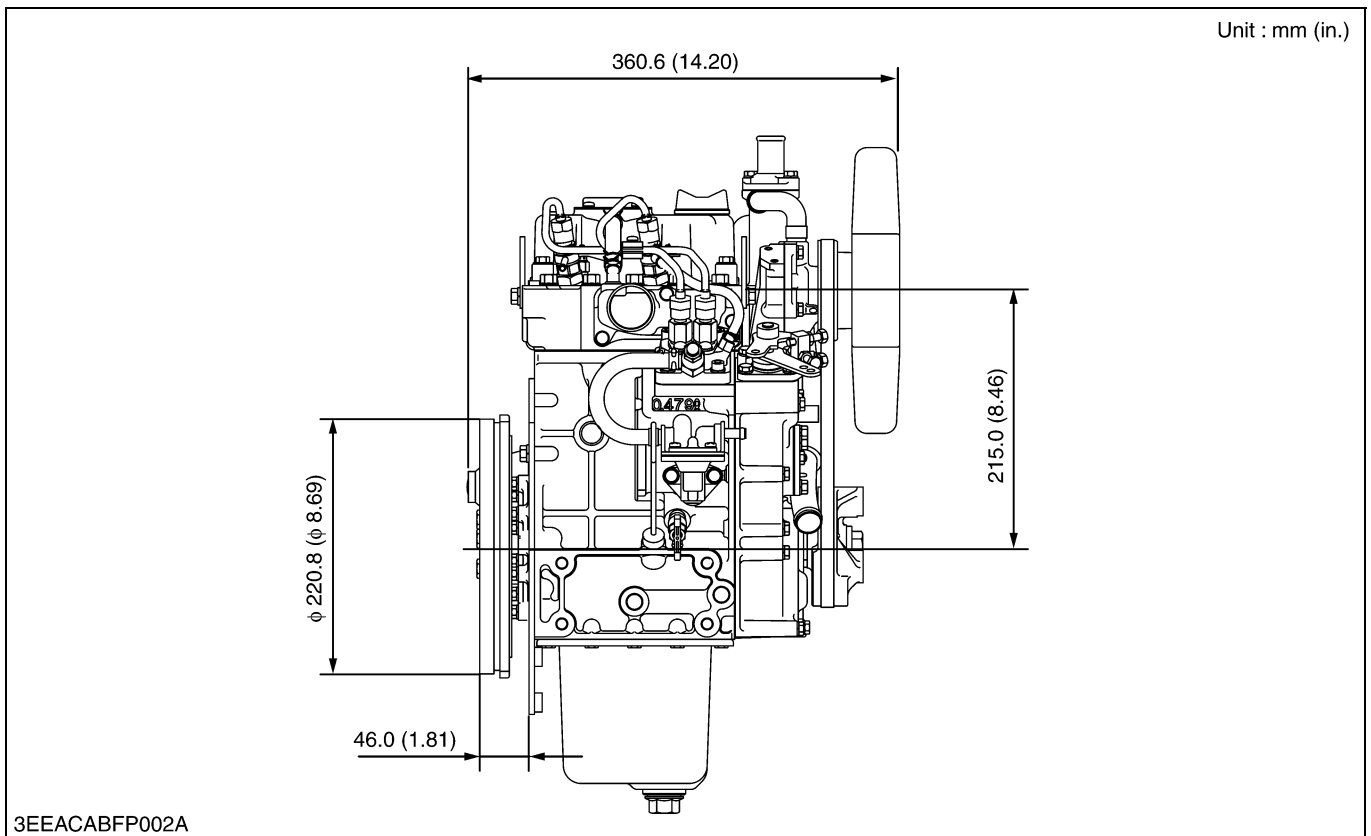
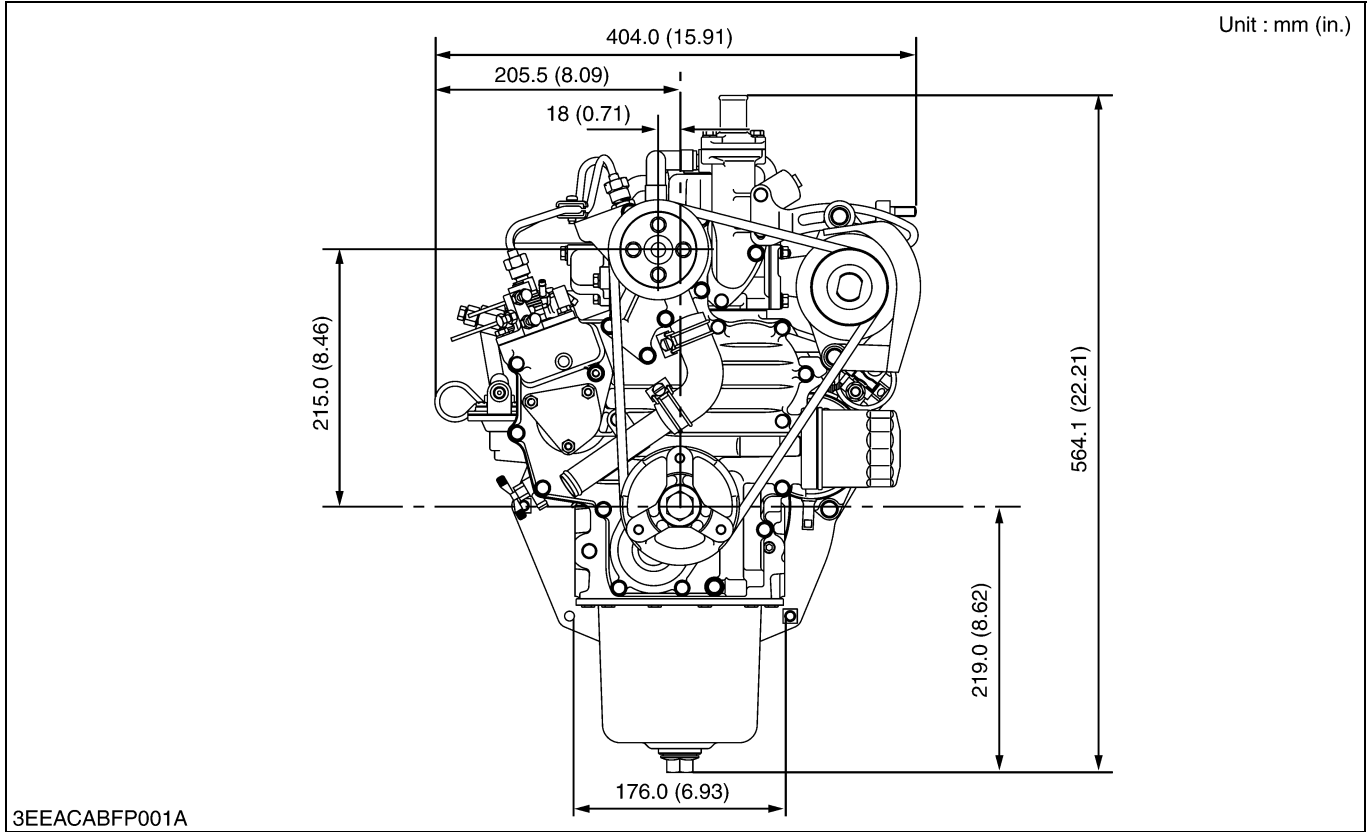

9Y1210785INI0007US0

Z602-E4B

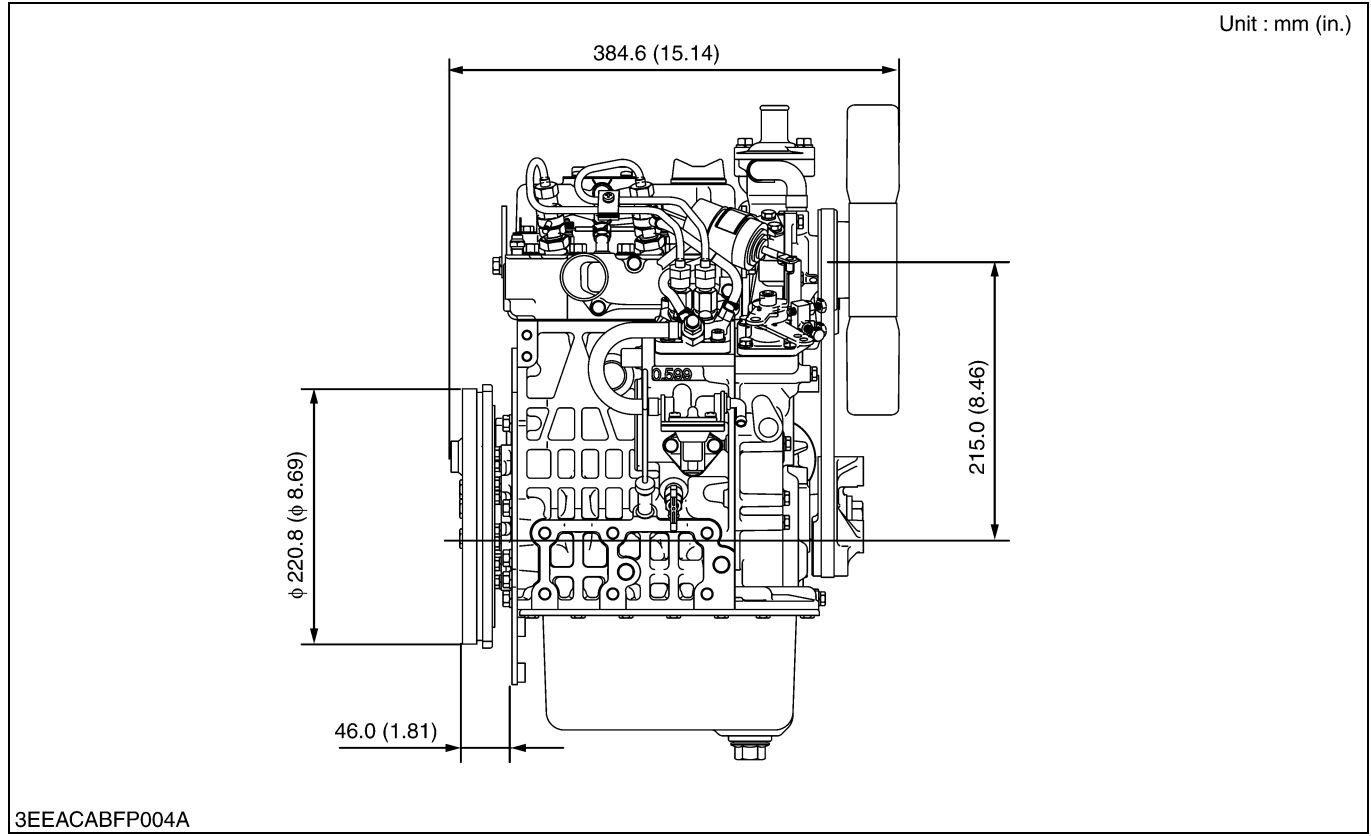
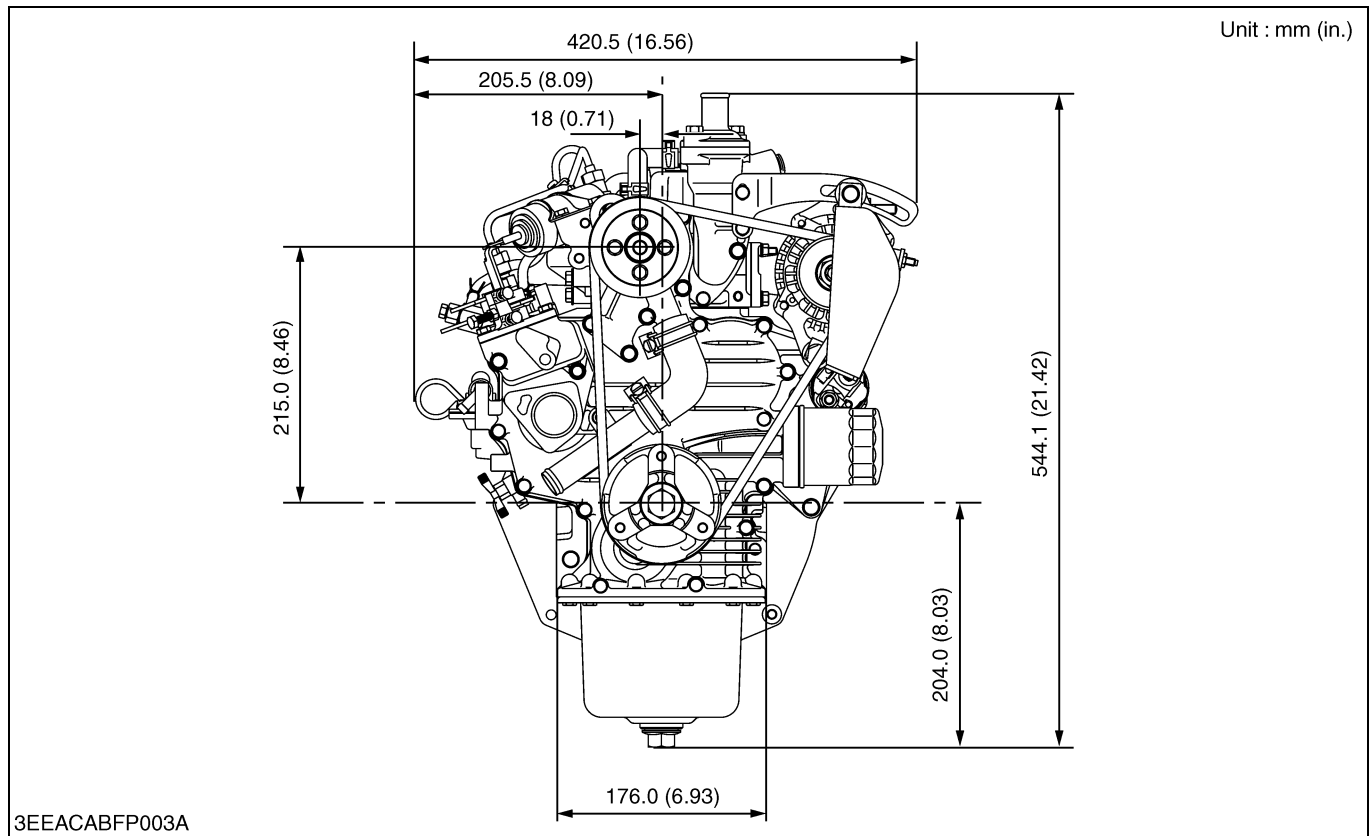

9Y1210785INI0008US0

D722-E4B

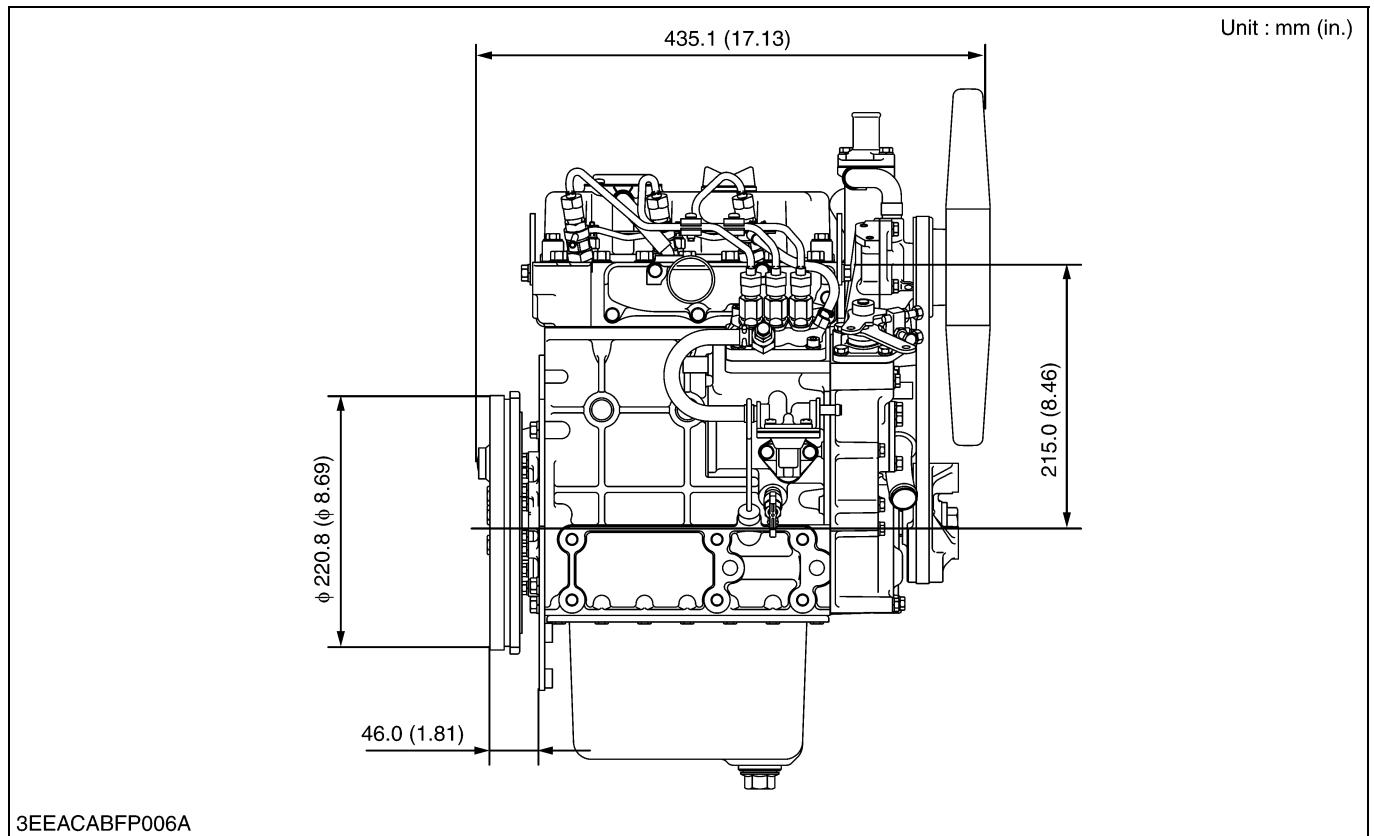
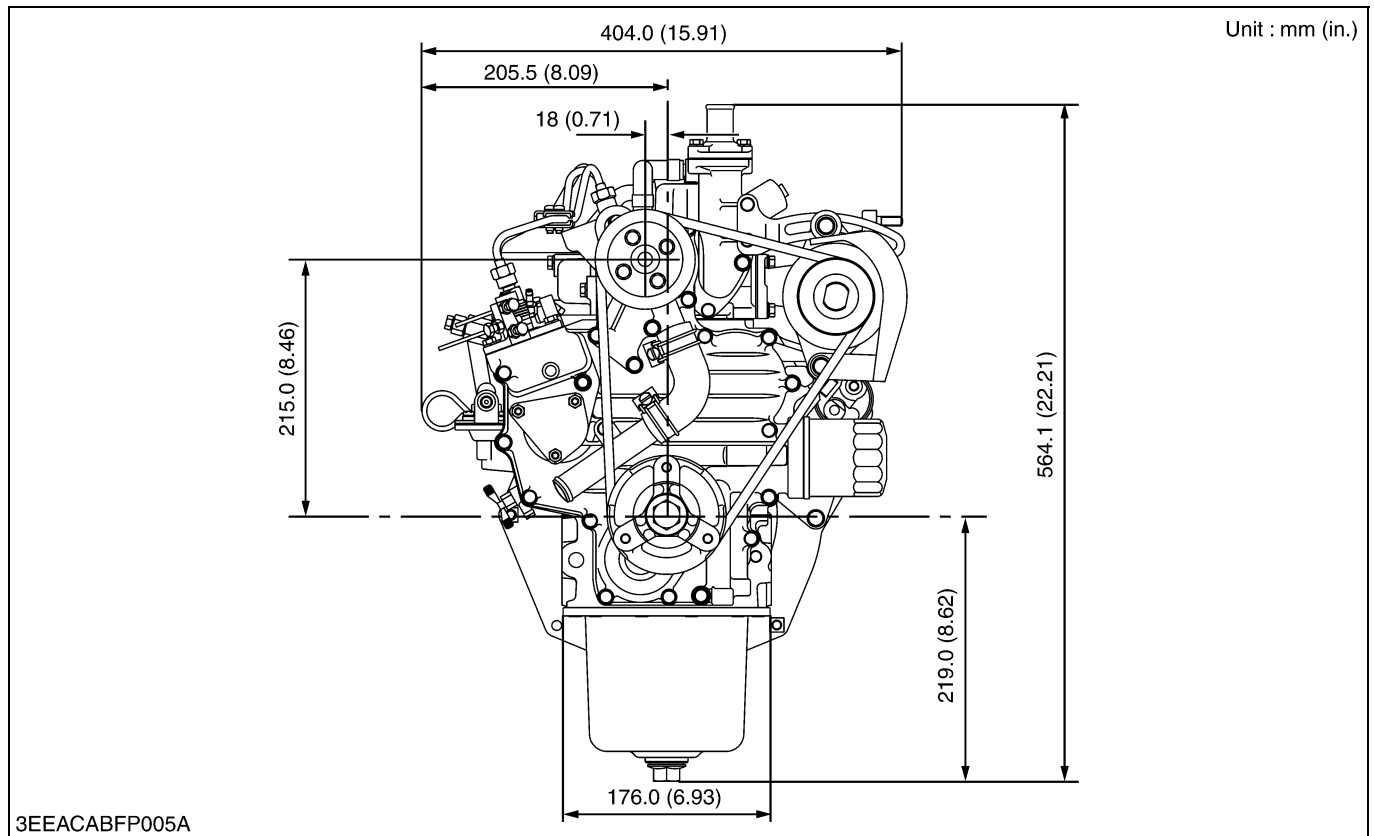

9Y1210785INI0009US0

D782-E4B

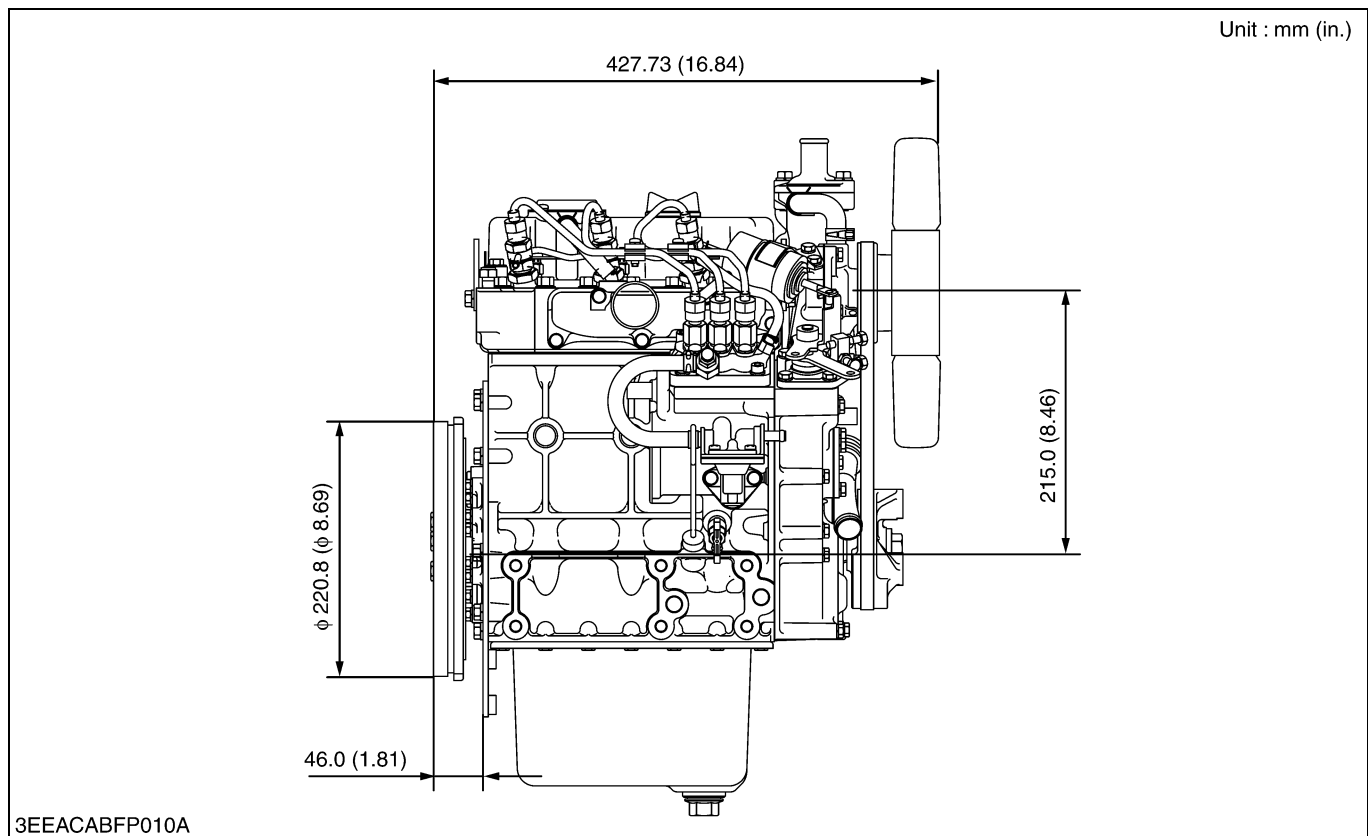
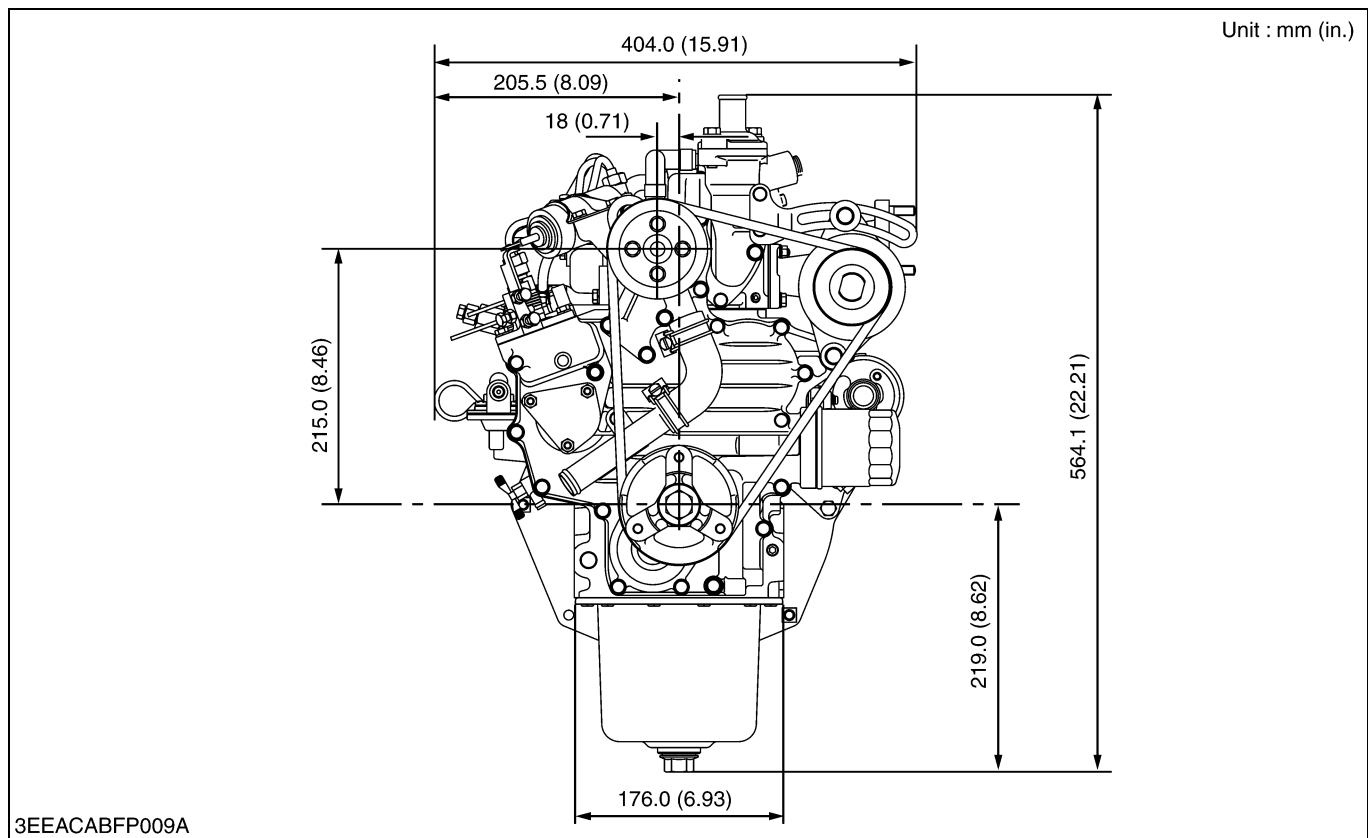

9Y1210785INI0010US0

D902-E4B

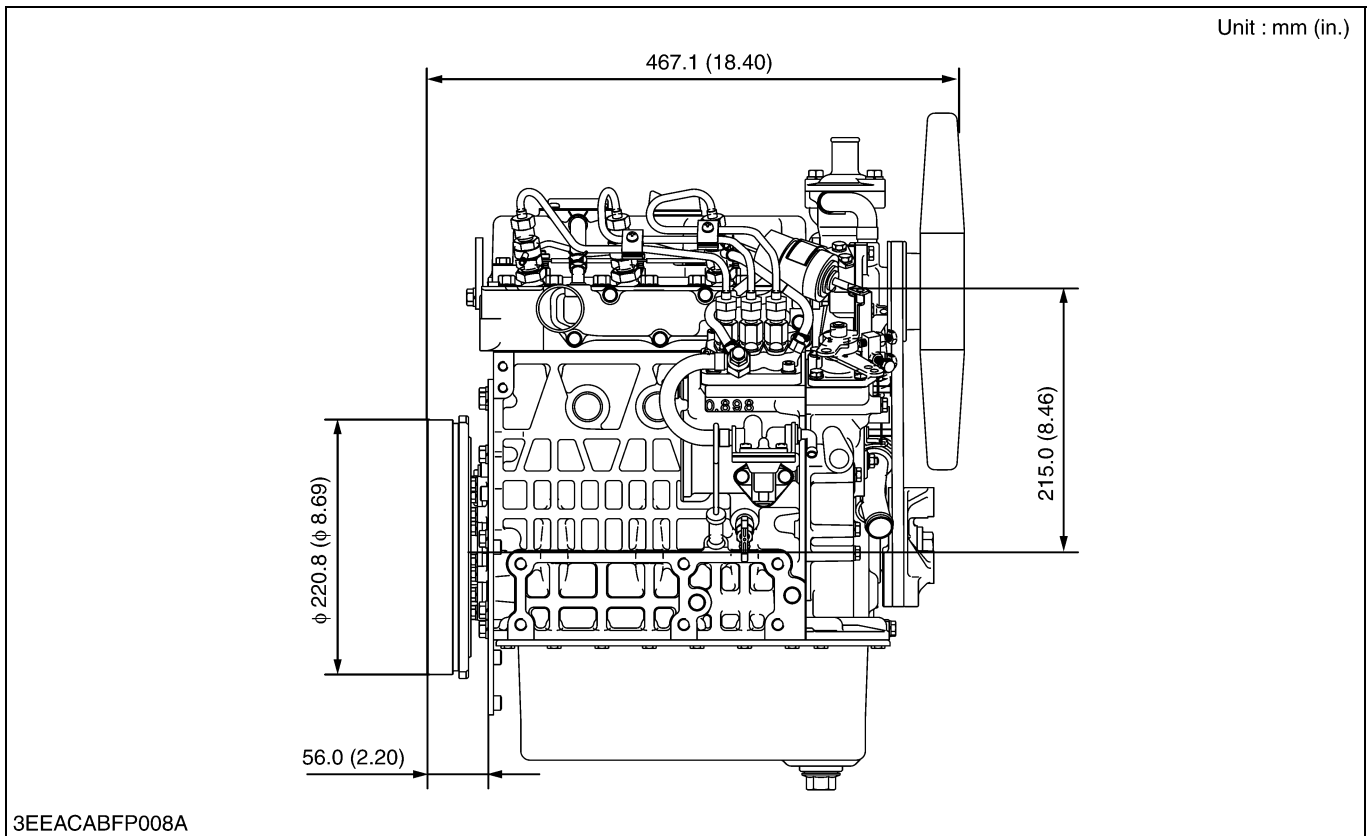
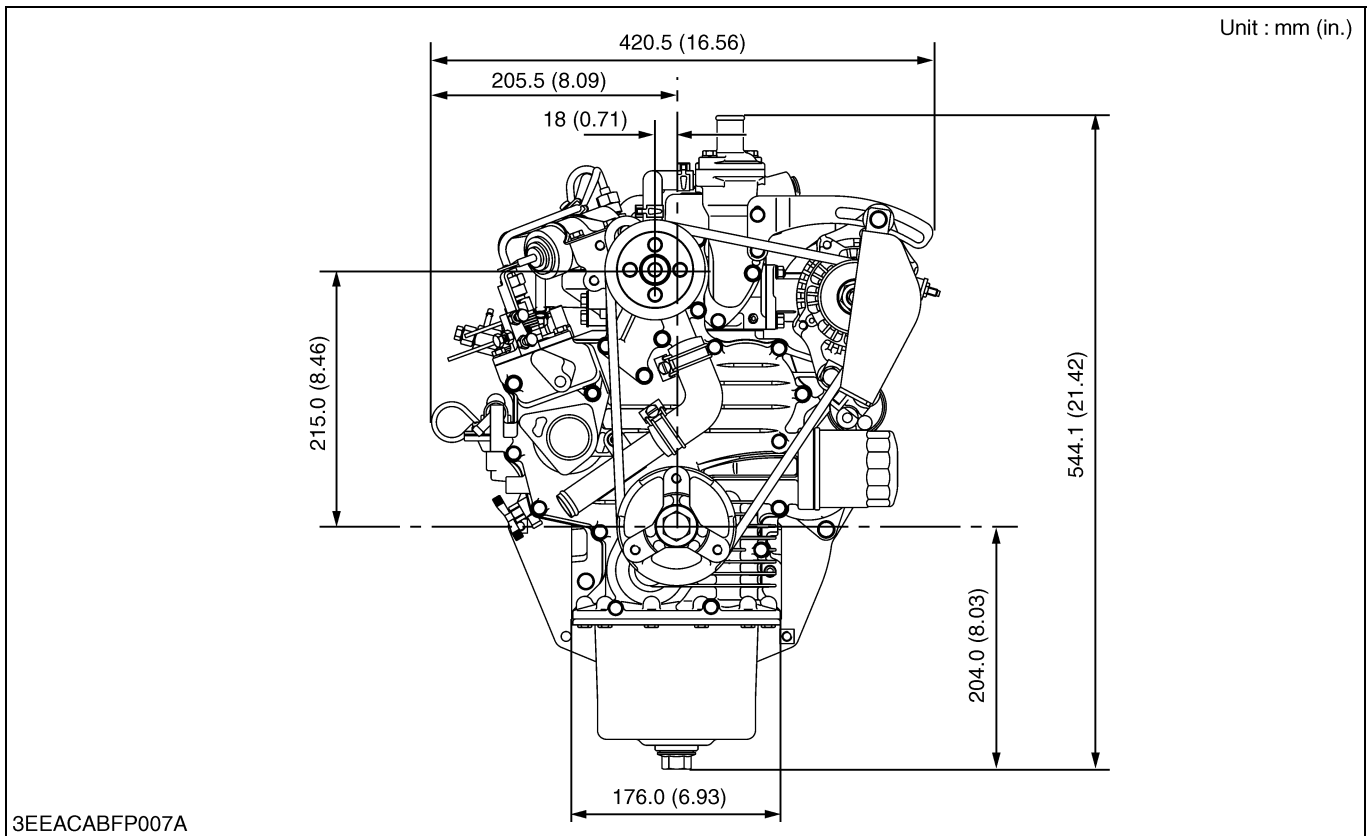

9Y1210785INI0011US0

G GENERAL

GENERAL

CONTENTS

1. ENGINE IDENTIFICATION	G-1
[1] MODEL NAME AND ENGINE SERIAL NUMBER.....	G-1
[2] E4B ENGINE	G-3
[3] CYLINDER NUMBER.....	G-3
2. GENERAL PRECAUTION	G-4
3. MAINTENANCE CHECK LIST	G-5
4. CHECK AND MAINTENANCE	G-7
[1] DAILY CHECK POINTS	G-7
[2] CHECK POINTS OF INITIAL 50 HOURS	G-9
[3] CHECK POINT OF EVERY 50 HOURS	G-11
[4] CHECK POINTS OF EVERY 75 HOURS	G-12
[5] CHECK POINTS OF EVERY 100 HOURS	G-13
[6] CHECK POINTS OF EVERY 150 HOURS	G-15
[7] CHECK POINTS OF EVERY 200 HOURS	G-16
[8] CHECK POINTS OF EVERY 400 HOURS	G-17
[9] CHECK POINTS OF EVERY 500 HOURS	G-18
[10]CHECK POINTS OF EVERY 1 OR 2 MONTHS	G-20
[11]CHECK POINT OF EVERY YEAR	G-22
[12]CHECK POINT OF EVERY 800 HOURS	G-23
[13]CHECK POINTS OF EVERY 1500 HOURS	G-24
[14]CHECK POINTS OF EVERY 3000 HOURS	G-26
[15]CHECK POINTS OF EVERY 2 YEARS	G-29
5. SPECIAL TOOLS	G-33

1. ENGINE IDENTIFICATION

[1] MODEL NAME AND ENGINE SERIAL NUMBER

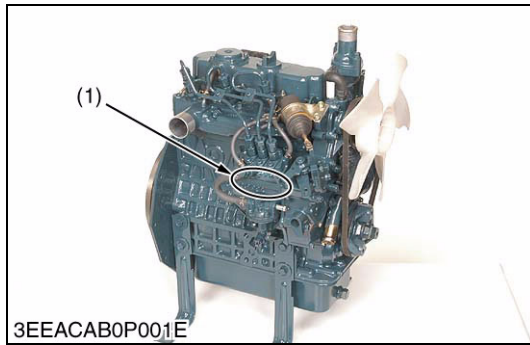

When contacting the manufacture, always specify your engine model name and serial number.

The engine model and its serial number need to be identified before the engine can be serviced or parts replaced.

■ Engine Serial Number

The engine serial number is an identification number.

It is marked after the engine model name.

It indicates the engine series, the production year and month, and the lot number.

Engine Series

Number or Alphabet	Series	Number or Alphabet	Series
1	05 (include: WG)	6	GZ, OC, AC, EA, E
2	V3	7	03
3	08	8	07
4	SM (include: WG)	A	EA, RK
5	Air Cooled Gasoline	B	03 (KET Production)

Production Year

Alphabet or Number	Year	Alphabet or Number	Year
1	2001	F	2015
2	2002	G	2016
3	2003	H	2017
4	2004	J	2018
5	2005	K	2019
6	2006	L	2020
7	2007	M	2021
8	2008	N	2022
9	2009	P	2023
A	2010	R	2024
B	2011	S	2025
C	2012	T	2026
D	2013	V	2027
E	2014		

(1) Engine Model Name and Serial Number

(To be continued)

(Continued)

Production Month and Lot Number

Month	Engine Lot Number	
January	A0001 ~ A9999	B0001 ~
February	C0001 ~ C9999	D0001 ~
March	E0001 ~ E9999	F0001 ~
April	G0001 ~ G9999	H0001 ~
May	J0001 ~ J9999	K0001 ~
June	L0001 ~ L9999	M0001 ~
July	N0001 ~ N9999	P0001 ~
August	Q0001 ~ Q9999	R0001 ~
September	S0001 ~ S9999	T0001 ~
October	U0001 ~ U9999	V0001 ~
November	W0001 ~ W9999	X0001 ~
December	Y0001 ~ Y9999	Z0001 ~

* Alphabetical letters "I" and "O" are not used.

(a) (b)(c)(d) (e)
e.g. D902 - 4 CW1237

- (a) **D902**: Engine Model Name
- (b) **4**: Engine Series (SM series)
- (c) **C**: Production Year (2012)
- (d) **W**: Production Month (November)
- (e) **1237**: Lot Number: (**0001 ~ 9999** or **A001 ~ Z999**)

9Y1210785GEG0001US0

[2] E4B ENGINE

[Example : Engine Model Name D902-**E4B**-XXXX]

The emission controls previously implemented in various countries to prevent air pollution will be stepped up as Non-Road Emission Standards continue to change. The timing or applicable date of the specific Non-Road Emission regulations depends on the engine output classification.

Over the past several years, KUBOTA has been supplying diesel engines that comply with regulations in the respective countries affected by Non-Road Emission regulations. For KUBOTA Engines, E4B will be the designation that identifies engine models affected by the next emission phase (See the table below).

When servicing or repairing ###-E4B series engines, use only replacement parts for that specific E4B engine, designated by the appropriate E4B KUBOTA Parts List and perform all maintenance services listed in the appropriate KUBOTA Operator's Manual or in the appropriate E4B KUBOTA Workshop Manual. Use of incorrect replacement parts or replacement parts from other emission level engines (for example: E2B engines), may result in emission levels out of compliance with the original E4B design and EPA or other applicable regulations. Please refer to the emission label located on the engine head cover to identify Output classification and Emission Control Information. E4B engines are identified with "EF" at the end of the Model designation, on the US EPA label. Please note : E4B is not marked on the engine.

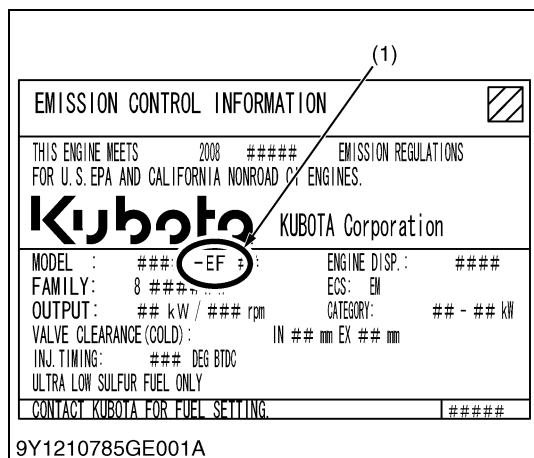

Category (1)	Engine output classification	EPA regulation
EF	Less than 19 kW	Tier 4

- (1) "E4B" engines are identified with "EF" at the end of the Model designation, on the US EPA label.
 "E4B" designates Tier 4, depending on engine output classification.

9Y1210785GEG0002US0

[3] CYLINDER NUMBER

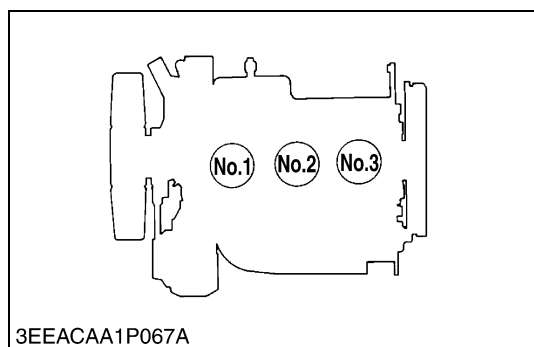

The cylinder numbers of KUBOTA diesel engine are designated as shown in the figure.

The sequence of cylinder numbers is given as No.1, No.2 and No.3 starting from the gear case side.

9Y1210785GEG0003US0

2. GENERAL PRECAUTION

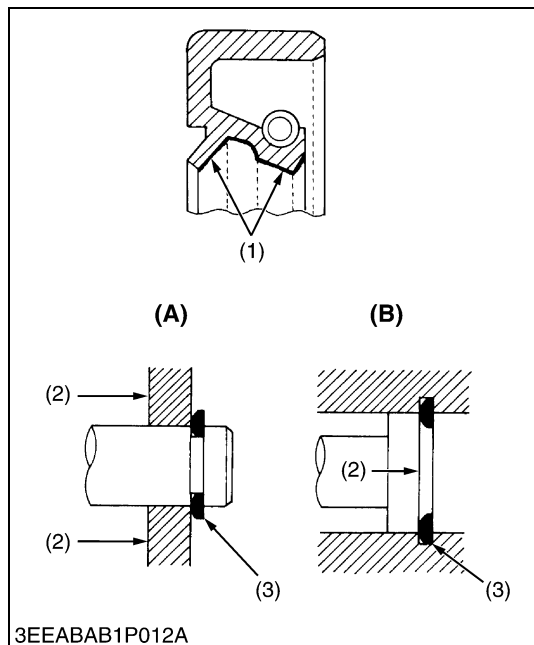

- When you disassemble, carefully put the parts in a clean area to make it easy to find the parts. You must install the screws, bolts and nuts in their initial position to prevent the reassembly errors.
- When it is necessary to use special tools, use KUBOTA special tools. Refer to the drawings when you make special tools that you do not use frequently.
- Before you disassemble or repair machine, make sure that you always disconnect the ground cable from the battery first.
- Remove oil and dirt from parts before you measure.
- Use only KUBOTA genuine parts for replacement to keep the machine performance and to make sure of safety.
- You must replace the gaskets and O-rings when you assemble again. Apply grease (1) to new O-rings or oil seals before you assemble.
- When you assemble the external or internal snap rings, make sure that the sharp edge (3) faces against the direction from which force (2) is applied.
- Make sure that you try to operate the engine after you repair or assemble it. Do not try to give a heavy load immediately, if not, you can cause serious damage to the engine.

- (1) Grease
 (2) Force
 (3) Sharp Edge

- (A) External Snap Ring**
(B) Internal Snap Ring

WSM000001GEG0091US0

3. MAINTENANCE CHECK LIST

To maintain long-lasting and safe engine performance, make it a rule to carry out regular inspections by following the table below.

Item		Service Interval												
		Every												
		50 hrs	75 hrs	100 hrs	150 hrs	200 hrs	400 hrs	500 hrs	1 or 2 months	1 year	800 hrs	1500 hrs	3000 hrs	2 years
*Checking fuel hoses and clamp bands		☆												
Changing Engine oil	(1) Oil pan depth (101 mm, 3.98 in.)	★	☆											
	(2) Oil pan depth (121 mm, 4.76 in.)	★		☆										
	(3) Extended oil pan depth (101 mm, 3.98 in.)	★		☆										
Checking fan belt tension and damage				☆										
*Cleaning air cleaner element (Replace the element after 6 times cleaning)				☆										
Cleaning fuel filter (element type)				☆										
Checking battery electrolyte level				☆										
Replacing oil filter cartridge	(1) Oil pan depth (101 mm, 3.98 in.)	★			☆									
	(2) Oil pan depth (121 mm, 4.76 in.)	★				☆								
	(3) Extended oil pan depth (101 mm, 3.98 in.)	★				☆								
Checking radiator hoses and clamp bands						☆								
*Checking intake air line						☆								
*Replacing fuel filter							☆							
Cleaning water jacket and radiator interior								☆						
Replacing fan belt								☆						
Recharging battery									☆					
*Replacing air cleaner element										☆				
Checking valve clearance											☆			
*Checking injection nozzle condition												☆		
*Checking injection timing													☆	
*Checking injection pump													☆	
*Replacing intake air line														☆
Replacing battery														☆
Replacing radiator hoses and clamp bands														☆
*Replacing fuel hoses and clamp bands														☆
Changing radiator coolant (L.L.C.)														☆

- (1) : This oil pan depth is optional for Z482-E4B and D722-E4B.
- (2) : This oil pan depth is standard for Z482-E4B, D722-E4B and D782-E4B.
- (3) : This oil pan depth is standard for Z602-E4B and D902-E4B.
- ★ : Change engine oil and replace oil filter cartridge after the first 50 hours of operation.
- * : The items listed above (* marked) are registered as emission related critical parts by KUBOTA in the U.S. EPA nonroad emission regulation. As the engine owner, you are responsible for the performance of the required maintenance on the engine according to the above instruction.



• **When changing or inspecting, be sure to level and stop the engine.**

■ **NOTE**

Engine Oil :

- Refer to the following table for the suitable American Petroleum Institute (API) classification of engine oil according to the engine type (with internal EGR, external EGR or non-EGR) and the Fuel Type Used : (Low Sulfur, Ultra Low Sulfur or High Sulfur Fuels).

Fuel Type	Engine oil classification (API classification)	
	Engines with non-EGR Engines with internal EGR	Engines with external EGR
High Sulfur Fuel [0.05 % (500 ppm) ≤ Sulfur Content < 0.50 % (5000 ppm)]	CF (If the "CF-4, CG-4, CH-4, or CI-4" engine oil is used with a high-sulfur fuel, change the engine oil at shorter intervals. (approximately half))	–
Low Sulfur Fuel [Sulfur Content < 0.05 % (500 ppm)] or Ultra Low Sulfur Fuel [Sulfur Content < 0.0015 % (15 ppm)]	CF, CF-4, CG-4, CH-4 or CI-4	CF or CI-4 (Class CF-4, CG-4 and CH-4 engine oils cannot be used on EGR type engines.)

EGR : Exhaust Gas Re-circulation

- **CJ-4 classification oil is intended for use in engines equipped with DPF (Diesel Particulate Filter) and is Not Recommended for use in KUBOTA E3 specification engines.**
- **Oil used in the engine should have API classification and Proper SAE Engine Oil Viscosity according to the ambient temperatures where the engine is operated.**
- **With strict emission control regulations now in effect, the CF-4 and CG-4 engine oils have been developed for use with low sulfur fuels, for On-Highway vehicle engines. When a Non-Road engine runs on high sulfur fuel, it is advisable to use a "CF or better" classification engine oil with a high Total Base Number (a minimum TBN of 10 is recommended).**

Fuel :

- **Cetane Rating : The minimum recommended Fuel Cetane Rating is 45. A cetane rating greater than 50 is preferred, especially for ambient temperatures below –20 °C (–4 °F) or elevations above 1500 m (5000 ft).**
- **Diesel Fuel Specification Type and Sulfur Content % (ppm) used, must be compliant with all applicable emission regulations for the area in which the engine is operated.**
- **Use of diesel fuel with sulfur content less than 0.10 % (1000 ppm) is strongly recommended.**
- **If high-sulfur fuel (sulfur content 0.50 % (5000 ppm) to 1.0 % (10000 ppm)) is used as a diesel fuel, change the engine oil and oil filter at shorter intervals. (approximately half)**
- **DO NOT USE Fuels that have sulfur content greater than 1.0 % (10000 ppm).**
- **Diesel fuels specified to EN 590 or ASTM D975 are recommended.**
- **No.2-D is a distillate fuel of lower volatility for engines in industrial and heavy mobile service. (SAE J313 JUN87)**
- **Since KUBOTA diesel engines of less than 56 kW (75 hp) utilize EPA Tier 4 and Interim Tier 4 standards, the use of low sulfur fuel or ultra low sulfur fuel is mandatory for these engines, when operated in US EPA regulated areas. Therefore, please use No.2-D S500 or S15 diesel fuel as an alternative to No.2-D, and use No.1-D S500 or S15 diesel fuel as an alternative to No.1-D for ambient temperatures below –10 °C (14 °F).**

- 1) SAE : Society of Automotive Engineers
- 2) EN : European Norm
- 3) ASTM : American Society of Testing and Materials
- 4) US EPA : United States Environmental Protection Agency
- 5) No.1-D or No.2-D, S500 : Low Sulfur Diesel (LSD) less than 500 ppm or 0.05 wt.%
No.1-D or No.2-D, S15 : Ultra Low Sulfur Diesel (ULSD) 15 ppm or 0.0015 wt.%

9Y1210785GEG0005US0

4. CHECK AND MAINTENANCE

[1] DAILY CHECK POINTS



Checking Engine Oil Level

1. Level the engine.
2. To check the oil level, draw out the dipstick (1), wipe it clean, reinsert it, and draw it out again.
Check to see that the oil level lies between the two notches.
3. If the level is too low, add new oil to the specified level.

■ IMPORTANT

- When using an oil of different maker or viscosity from the previous, drain old oil. Never mix two different types of oil.

■ NOTE

- Be sure to inspect the engine, locating it on a horizontal place. If placed on gradients, accurately, oil quantity may not be measured.
- Be sure to keep the oil level between upper and lower limits of the dipstick. Too much oil may cause a drop in output or excessive blow-by gas. On the closed breather type engine in which mist is sucked through port, too much oil may caused oil hammer. While too little oil, may seize the engine's rotating and sliding parts.

(1) Dipstick

9Y1210785GEG0006US0

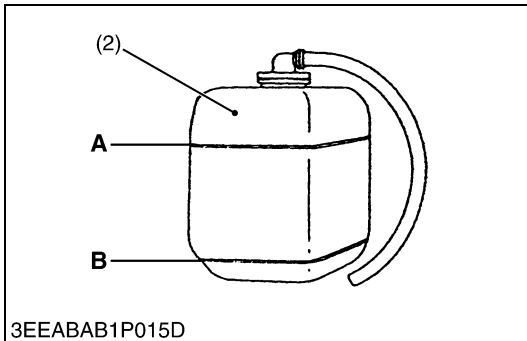
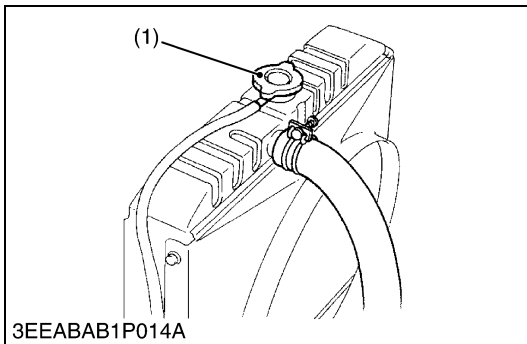

Checking and Replenish Coolant

1. Without recovery tank (2) :
Remove the radiator cap (1) and check to see that the coolant level is just below the port.
With recovery tank (2) :
Check to see that the coolant level lies between **FULL "A"** and **LOW "B"**.
2. If coolant level is too low, check the reason for decreasing coolant.

(Case 1)

If coolant is decreasing by evaporation, replenish only fresh, soft water.

(Case 2)

If coolant is decreasing by leak, replenish coolant of the same manufacture and type in the specified mixture ratio (fresh, soft water and L.L.C.). If the coolant brand cannot be identified, drain out all of the remaining coolant and refill with a totally new brand of coolant mix.



CAUTION

- Do not remove the radiator cap until coolant temperature is below its boiling point. Then loosen the cap slightly to relieve any excess pressure before removing the cap completely.
- **IMPORTANT**
- During filling the coolant, air must be vented from the engine coolant passages. The air vents by jiggling the radiator upper and lower hoses.
- Be sure to close the radiator cap securely. If the cap is loose or improperly closed, coolant may leak out and the engine could overheat.
- Do not use an antifreeze and scale inhibitor at the same time.
- Never mix the different type or brand of L.L.C..

- (1) Radiator Cap
(2) Recovery Tank

A : FULL

B : LOW

9Y1210785GEG0007US0

[2] CHECK POINTS OF INITIAL 50 HOURS

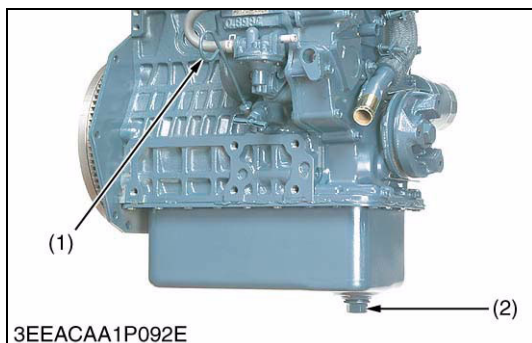

Changing Engine Oil

CAUTION

- **Be sure to stop engine before changing engine oil.**
- 1. Start and warm up the engine for approx. 5 minutes.
- 2. Place an oil pan underneath the engine.
- 3. To drain the used oil, remove the drain plug (2) at the bottom of the engine and drain the oil completely.
- 4. Screw the drain plug (2).
- 5. Fill new oil up to upper line on the dipstick (1).

IMPORTANT

- **When using an oil of different maker or viscosity from the previous one, remove all of the old oil.**
- **Never mix two different types of oil.**
- **Engine oil should have properties of API classification CF (See page G-6).**
- **Use the proper SAE Engine Oil according to ambient temperature.**
- **Upon an oil change, be sure to replace the gasket with new one.**

Above 25 °C (77 °F)	SAE 30 or SAE 10W-30, SAE 10W-40
0 °C to 25 °C (32 °F to 77 °F)	SAE 20 or SAE 10W-30, SAE 10W-40
Below 0 °C (32 °F)	SAE 10W or SAE 10W-30, SAE 10W-40

Model	Engine oil capacity	
	Oil pan depth	
	101 mm (3.98 in.)	121 mm (4.76 in.)
*Z482-E4B	2.1 L 0.55 U.S.gals	2.5 L 0.66 U.S.gals
*D722-E4B	3.2 L 0.85 U.S.gals	3.8 L 1.0 U.S.gals
D782-E4B	–	3.6 L 0.95 U.S.gals
Z602-E4B	2.5 L 0.66 U.S.gals	–
D902-E4B	3.7 L 0.98 U.S.gals	–

*101 mm (3.98 in.) oil pan depth is optional.

Tightening torque	Drain plug with copper gasket	M12 × 1.25	33 to 37 N·m 3.3 to 3.8 kgf·m 24 to 27 lbf·ft
		M22 × 1.5	64 to 73 N·m 6.5 to 7.5 kgf·m 47 to 54 lbf·ft
	Drain plug with rubber coated gasket	M22 × 1.5	45 to 53 N·m 4.5 to 5.5 kgf·m 33 to 39 lbf·ft

(1) Dipstick

(2) Drain Plug

9Y1210785GEG0008US0

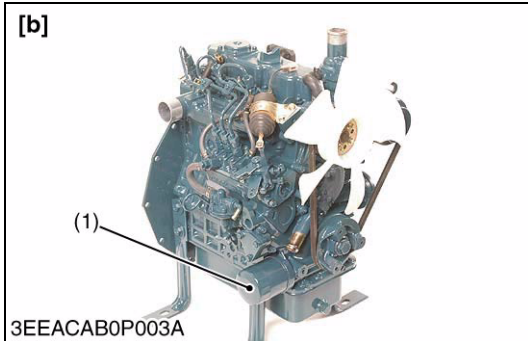

Replacing Oil Filter Cartridge

⚠ CAUTION

- **Be sure to stop the engine before changing filter cartridge.**
1. Remove the oil filter cartridge (1) with the filter wrench.
 2. Apply a slight coat of oil onto the new cartridge gasket.
 3. To install the new cartridge, screw it in by hand. Over tightening may cause deformation of rubber gasket.
 4. After the new cartridge has been replaced, the engine oil normally decrease a little. Thus see that the engine oil does not leak through the seal and be sure to read the oil level on the dipstick. Then, replenish the engine oil up to the specified level.

■ IMPORTANT

- **To prevent serious damage to the engine, replacement element must be highly efficient. Use only a KUBOTA genuine filter or its equivalent.**

■ NOTE

- **The oil pan of 101 mm (3.98 in.) depth is optional for Z482-E4B and D722-E4B. This service interval is every 150 hours.**

(1) Engine Oil Filter Cartridge

[a] Standard Type

[b] One-side Maintenance Type

9Y1210785GEG0009US0

[3] CHECK POINT OF EVERY 50 HOURS

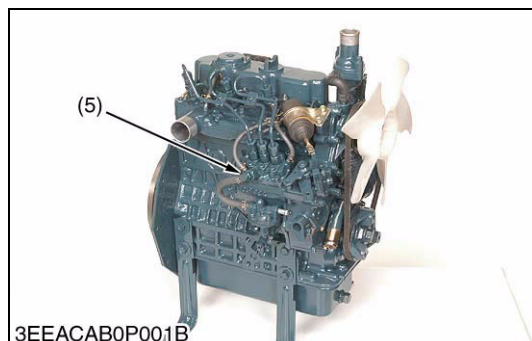
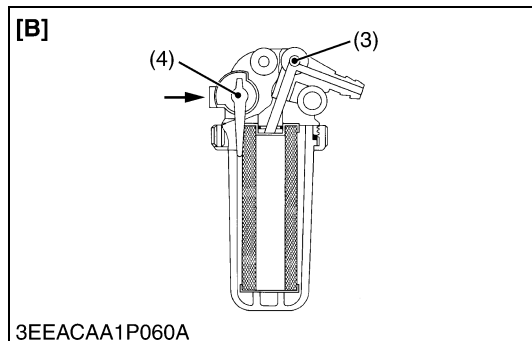
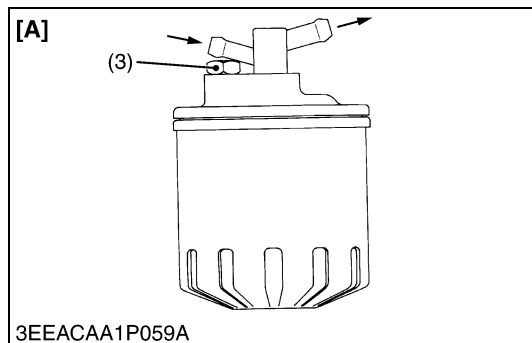
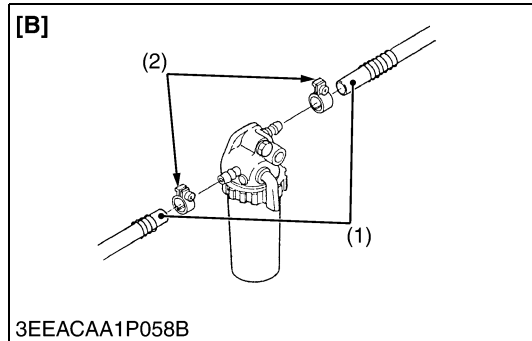
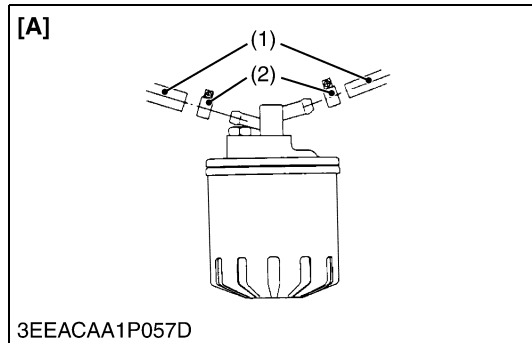

Checking Fuel Hose

1. If the clamp (2) is loose, apply oil to the threads and securely retighten it.
2. The fuel hose (1) is made of rubber and ages regardless of the period service.
Change the fuel hose together with the clamp every two years.
3. However, if the fuel hose and clamp are found to be damaged or deteriorate earlier than two years, then change or remedy.
4. After the fuel hose and the clamp have been changed, bleed the fuel system.

⚠ CAUTION

- Stop the engine when attempting the check and change prescribed above.

(When bleeding fuel system)

1. Fill the tank with fuel and open the cock (4). ([B] only.)
2. Loosen the air vent plug (3) of the fuel filter a few turns.
3. Screw back the plug when bubbles do not come up any more.
4. Open the air vent cock (5) on top of the fuel injection pump.
5. If equipped electrical fuel feed pump, turn the key to **AC** position and pump the fuel up for 10 to 15 seconds.
If equipped mechanical fuel feed pump, set the stop lever on stop position and crank the engine for 10 to 15 seconds.
6. Close securely the air vent cock after air bleeding.

■ NOTE

- Always keep the air vent cock on the fuel injection pump closed except when air is vented, or it may cause the engine to stop.

- (1) Fuel Hose
(2) Clamp
(3) Air Vent Plug
(4) Fuel Cock
(5) Air Vent Cock

- [A] Cartridge Type
[B] Element Type

9Y1210785GEG0010US0

[4] CHECK POINTS OF EVERY 75 HOURS

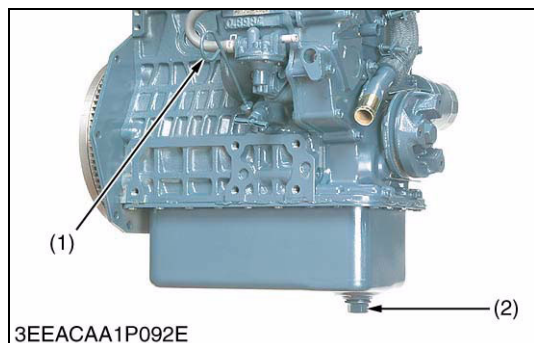

Changing Engine Oil (for Optional Depth Oil Pans)

CAUTION

- **Be sure to stop engine before changing engine oil.**
- 1. Start and warm up the engine for approx. 5 minutes.
- 2. Place an oil pan underneath the engine.
- 3. To drain the used oil, remove the drain plug (2) at the bottom of the engine and drain the oil completely.
- 4. Screw the drain plug (2).
- 5. Fill new oil up to upper line on the dipstick (1).

IMPORTANT

- **When using an oil of different maker or viscosity from the previous one, remove all of the old oil.**
- **Never mix two different types of oil.**
- **Engine oil should have properties of API classification CF (See page G-6).**
- **Use the proper SAE Engine Oil according to ambient temperature.**
- **Upon an oil change, be sure to replace the gasket with new one.**

Above 25 °C (77 °F)	SAE 30 or SAE 10W-30, SAE 10W-40
0 °C to 25 °C (32 °F to 77 °F)	SAE 20 or SAE 10W-30, SAE 10W-40
Below 0 °C (32 °F)	SAE 10W or SAE 10W-30 SAE 10W-40

Model	Engine oil capacity	
	Oil pan depth	
	101 mm (3.98 in.)	121 mm (4.76 in.)
*Z482-E4B	2.1 L 0.55 U.S.gals	2.5 L 0.66 U.S.gals
*D722-E4B	3.2 L 0.85 U.S.gals	3.8 L 1.0 U.S.gals
D782-E4B	–	3.6 L 0.95 U.S.gals
Z602-E4B	2.5 L 0.66 U.S.gals	–
D902-E4B	3.7 L 0.98 U.S.gals	–

*101 mm (3.98 in.) oil pan depth is optional.

Tightening torque	Drain plug with copper gasket	M12 × 1.25	33 to 37 N·m 3.3 to 3.8 kgf·m 24 to 27 lbf·ft
		M22 × 1.5	64 to 73 N·m 6.5 to 7.5 kgf·m 47 to 54 lbf·ft
	Drain plug with rubber coated gasket	M22 × 1.5	45 to 53 N·m 4.5 to 5.5 kgf·m 33 to 39 lbf·ft

(1) Dipstick

(2) Drain Plug

9Y1210785GEG0011US0

[5] CHECK POINTS OF EVERY 100 HOURS

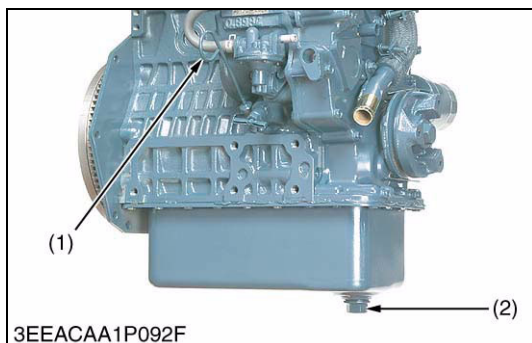

Changing Engine Oil (for Standard Depth Oil Pans)

⚠ CAUTION

- **Be sure to stop engine before changing engine oil.**
- 1. Start and warm up the engine for approx. 5 minutes.
- 2. Place an oil pan underneath the engine.
- 3. To drain the used oil, remove the drain plug (2) at the bottom of the engine and drain the oil completely.
- 4. Screw the drain plug (2).
- 5. Fill new oil up to upper line on the dipstick (1).

■ IMPORTANT

- **When using an oil of different maker or viscosity from the previous one, remove all of the old oil.**
- **Never mix two different types of oil.**
- **Engine oil should have properties of API classification CF (See page G-6).**
- **Use the proper SAE Engine Oil according to ambient temperature.**
- **Upon an oil change, be sure to replace the gasket with new one.**

Above 25 °C (77 °F)	SAE 30 or SAE 10W-30, SAE 10W-40
0 °C to 25 °C (32 °F to 77 °F)	SAE 20 or SAE 10W-30, SAE 10W-40
Below 0 °C (32 °F)	SAE 10W or SAE 10W-30 SAE 10W-40

Model	Engine oil capacity	
	Oil pan depth	
	101 mm (3.98 in.)	121 mm (4.76 in.)
*Z482-E4B	2.1 L 0.55 U.S.gals	2.5 L 0.66 U.S.gals
*D722-E4B	3.2 L 0.85 U.S.gals	3.8 L 1.0 U.S.gals
D782-E4B	–	3.6 L 0.95 U.S.gals
Z602-E4B	2.5 L 0.66 U.S.gals	–
D902-E4B	3.7 L 0.98 U.S.gals	–

*101 mm (3.98 in.) oil pan depth is optional.

Tightening torque	Drain plug with copper gasket	M12 × 1.25	33 to 37 N·m 3.3 to 3.8 kgf·m 24 to 27 lbf·ft
		M22 × 1.5	64 to 73 N·m 6.5 to 7.5 kgf·m 47 to 54 lbf·ft
	Drain plug with rubber coated gasket	M22 × 1.5	45 to 53 N·m 4.5 to 5.5 kgf·m 33 to 39 lbf·ft

(1) Dipstick

(2) Drain Plug

9Y1210785GEG0012US0

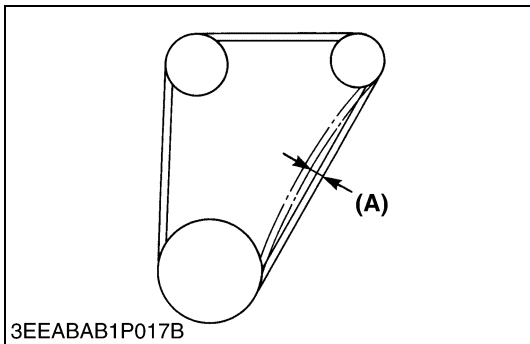

3EEABAB1P017B

Fan Belt Tension

1. Measure the deflection **(A)**, depressing the belt halfway between the fan drive pulley and alternator pulley at specified force 98 N (10 kgf, 22 lbf).
2. If the measurement is not within the factory specifications, loosen the alternator mounting screws and relocate the alternator to adjust.

Deflection (A)	Factory specification	7.0 to 9.0 mm 0.28 to 0.35 in.
-----------------------	-----------------------	-----------------------------------

(A) Deflection

9Y1210785GEG0013US0

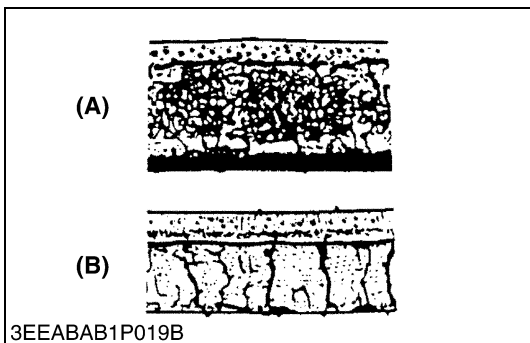

3EEABAB1P019B

Fan Belt Damage and Wear

1. Check the fan belt for damage.
2. If the fan belt is damaged, replace it.
3. Check if the fan belt is worn and sunk in the pulley groove.
4. If the fan belt is nearly worn out and deeply sunk in the pulley groove, replace it.

(A) Good

(B) Bad

9Y1210785GEG0014US0

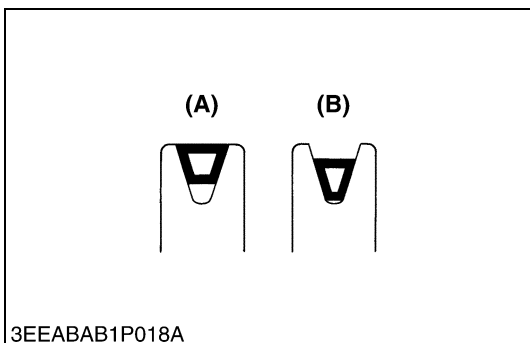

3EEABAB1P018A

Cleaning Air Cleaner Element

1. Remove the air cleaner element.
2. Use clean dry compressed air on the inside of the element. Pressure of compressed air must be under 205 kPa (2.1 kgf/cm², 30 psi). Maintain reasonable distance between the nozzle and the filter.

■ **NOTE**

- **The air cleaner uses a dry element. Never apply oil to it.**
- **Do not run the engine with filter element removed.**
- **Change the element once a year or every 6th cleaning.**

9Y1210785GEG0015US0

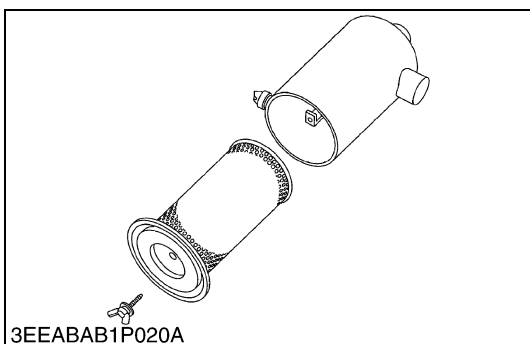

3EEABAB1P020A

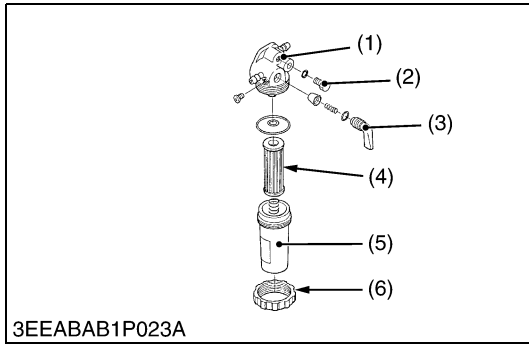

Cleaning Fuel Filter (Element Type only)

1. Close the fuel cock (3).
2. Unscrew the retaining ring (6) and remove the filter cup (5), and rinse the inside with kerosene.
3. Take out the element (4) and dip it in the kerosene to rinse.
4. After cleaning, reassemble the fuel filter, keeping out dust and dirt.
5. Bleed the fuel system.

IMPORTANT

- If dust and dirt enter the fuel, the fuel injection pump and injection nozzle will wear quickly. To prevent this, be sure to clean the fuel filter cup (5) periodically.

- | | |
|-------------------|--------------------|
| (1) Cock Body | (4) Filter Element |
| (2) Air Vent Plug | (5) Filter Cup |
| (3) Fuel Cock | (6) Retaining Ring |

9Y1210785GEG0016US0

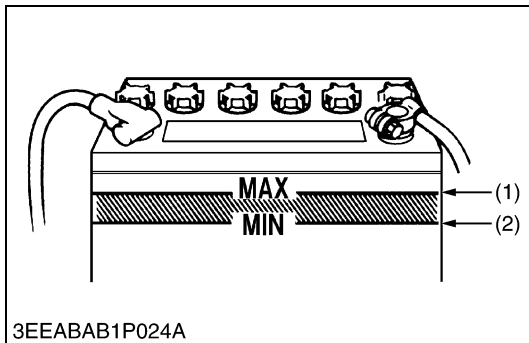

Checking Battery Electrolyte Level

1. Check the battery electrolyte level.
2. If the level is below than lower level line (2), and the distilled water to pour level of each cell.

- | | |
|----------------------|----------------------|
| (1) Upper Level Line | (2) Lower Level Line |
|----------------------|----------------------|

9Y1210785GEG0017US0

[6] CHECK POINTS OF EVERY 150 HOURS



Replacing Oil Filter Cartridge (for Optional Depth Oil Pans)

CAUTION

- Be sure to stop the engine before changing filter cartridge.
1. Remove the oil filter cartridge (1) with the filter wrench.
 2. Apply a slight coat of oil onto the new cartridge gasket.
 3. To install the new cartridge, screw it in by hand. Over tightening may cause deformation of rubber gasket.
 4. After the new cartridge has been replaced, the engine oil normally decrease a little. Thus see that the engine oil does not leak through the seal and be sure to read the oil level on the dipstick. Then, replenish the engine oil up to the specified level.

IMPORTANT

- To prevent serious damage to the engine, replacement element must be highly efficient. Use only a KUBOTA genuine filter or its equivalent.

- | | |
|---------------------------------|-------------------------------|
| (1) Engine Oil Filter Cartridge | [a] Standard Type |
| | [b] One-side Maintenance Type |

9Y1210785GEG0018US0

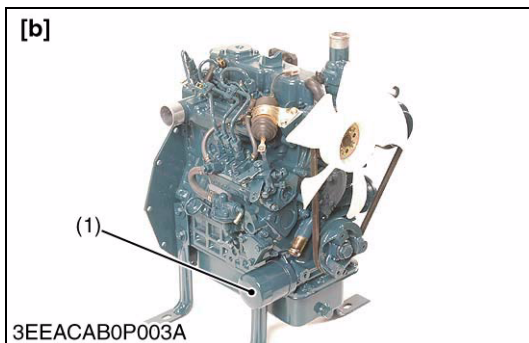

[7] CHECK POINTS OF EVERY 200 HOURS

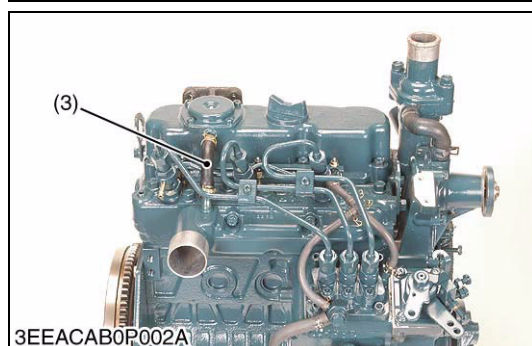
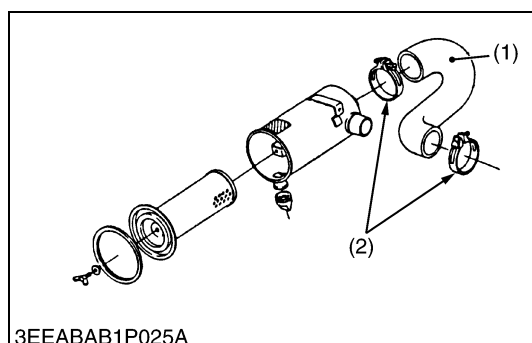
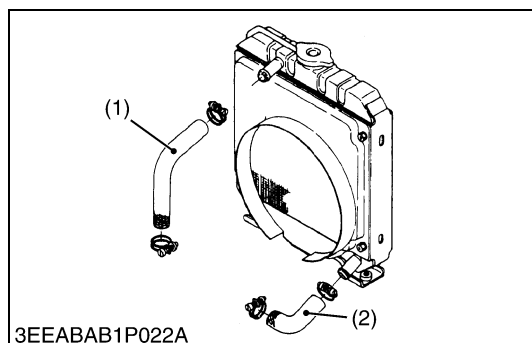
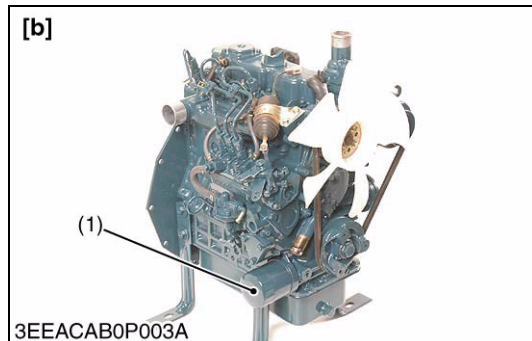

Replacing Oil Filter Cartridge (for Standard Depth Oil Pans)

⚠ CAUTION

- **Be sure to stop the engine before changing filter cartridge.**
1. Remove the oil filter cartridge (1) with the filter wrench.
 2. Apply a slight coat of oil onto the new cartridge gasket.
 3. To install the new cartridge, screw it in by hand. Over tightening may cause deformation of rubber gasket.
 4. After the new cartridge has been replaced, the engine oil normally decrease a little. Thus see that the engine oil does not leak through the seal and be sure to read the oil level on the dipstick. Then, replenish the engine oil up to the specified level.

■ IMPORTANT

- **To prevent serious damage to the engine, replacement element must be highly efficient. Use only a KUBOTA genuine filter or its equivalent.**

(1) Engine Oil Filter Cartridge

[a] Standard Type

[b] One-side Maintenance Type

9Y1210785GEG0019US0

Checking Radiator Hoses and Clamp Bands

1. Check to see if the radiator hoses are properly fixed every 200 hours of operation or every six months, whichever comes first.
2. If the clamp is loose, apply oil to the threads and retighten it securely.
3. The water hose is made of rubber and tends to age. It must be replaced every two years. Also replace the clamp and tighten it securely.

(1) Upper Hose

(2) Lower Hose

9Y1210785GEG0020US0

Checking Intake Air Line

1. Check to see if the intake air hose(s) (1) and the breather hose (3) are properly fixed every 200 hours of operation.
2. If the clamp (2) is loose, apply oil to the threads and retighten it securely.
3. The intake air hose(s) (1) and the breather hose (3) are made of rubber and tends to age. It must be changed every two years. Also change the clamp (2) and tighten it securely.

■ IMPORTANT

- **To prevent serious damage to the engine, keep out any dust inside the intake air line.**

(1) Intake Air Hose

(3) Breather Hose

(2) Clamp

9Y1210785GEG0021US0

[8] CHECK POINTS OF EVERY 400 HOURS

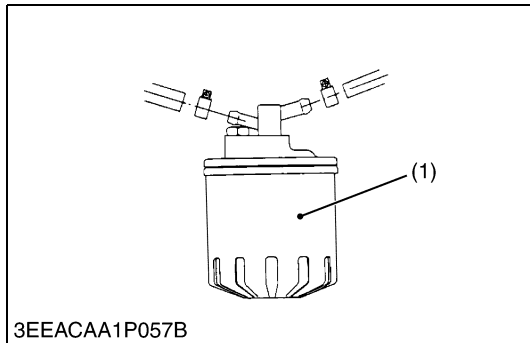

Replacing Fuel Filter Cartridge (Cartridge Type)

Water and dust in fuel are collected in the filter cartridge. So, change the filter cartridge every 400 hours service.

1. Remove the used filter cartridge with filter wrench.
2. Apply a thin film of fuel to the surface of new filter cartridge gasket before screwing on.
3. Then tighten enough by hand.
4. Loosen the air vent plug to let the air out.
5. Start engine and check for fuel leakage.

(1) Fuel Filter Cartridge

9Y1210785GEG0022US0

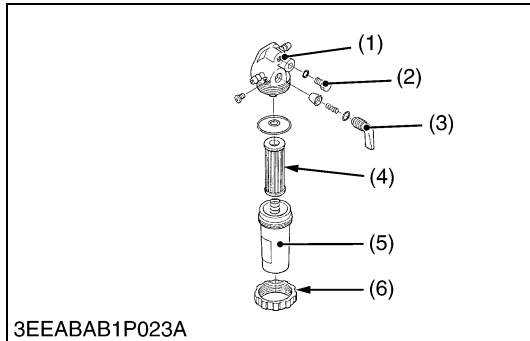

Replacing Fuel Filter Element (Element Type)

1. Close the fuel cock (3).
2. Unscrew the retaining ring (6) and remove the filter cup (5), and rinse the inside with kerosene.
3. Replace the filter element (4).
4. Reassemble the fuel filter, keeping out dust and dirt.
5. Bleed the fuel system.

(1) Cock Body
 (2) Air Vent Plug
 (3) Fuel Cock

(4) Filter Element
 (5) Filter Cup
 (6) Retaining Ring

9Y1210785GEG0023US0

[9] CHECK POINTS OF EVERY 500 HOURS

Cleaning Water Jacket and Radiator Interior

CAUTION

- Do not remove the radiator cap when the engine is hot. Then loosen cap slightly to the stop to relieve any excess pressure before removing cap completely.

1. Stop the engine and let cool down.
2. To drain the coolant, open the radiator drain plug (2) and remove the radiator cap (1). Then radiator cap (1) must be removed to completely drain the coolant. And open the drain cock (3).
3. After all coolant is drained, close the drain plug.
4. Fill with clean water and cooling system cleaner.
5. Follow directions of the cleaner instruction.
6. After flushing, fill with clean water and anti-freeze until the coolant level is just below the port. Install the radiator cap (1) securely.
7. Fill with coolant up to "FULL" (A) mark on the recovery tank (4).
8. Start and operate the engine for few minutes.
9. Stop the engine and let cool. Check coolant level of radiator and recovery tank (4) and add coolant if necessary.

■ IMPORTANT

- Do not start engine without coolant.
- Use clean, fresh, soft water and anti-freeze to fill the radiator and recovery tank.
- When the anti-freeze is mixed with fresh, soft water, the anti-freeze mixing ratio must be less than 50 %.
- Securely tighten radiator cap. If the cap is loose or improperly fitted, water may leak out and the engine could overheat.

- (1) Radiator Cap
 (2) Drain Plug
 (3) Drain Cock
 (4) Recovery Tank

A : Full
 B : Low

9Y1210785GEG0024US0

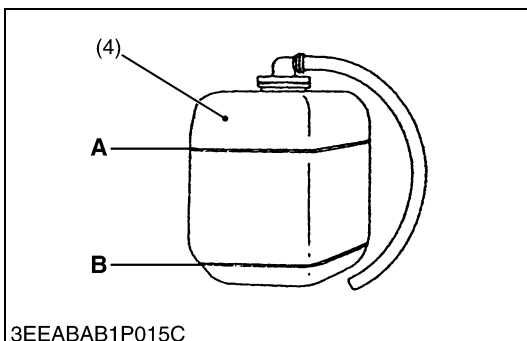
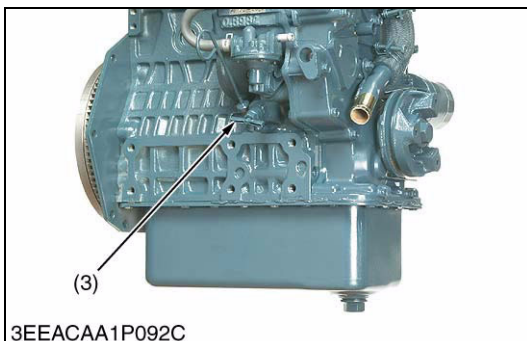
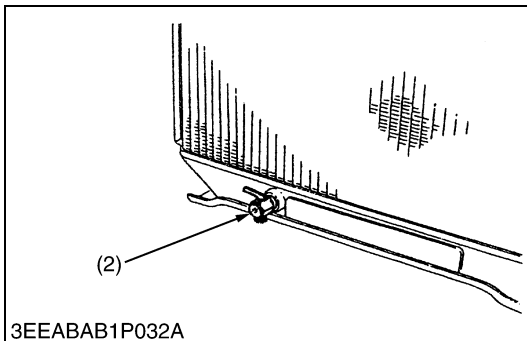
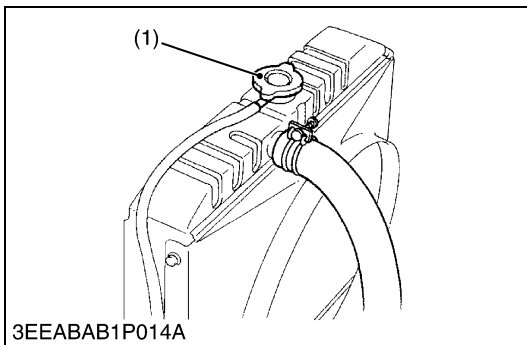

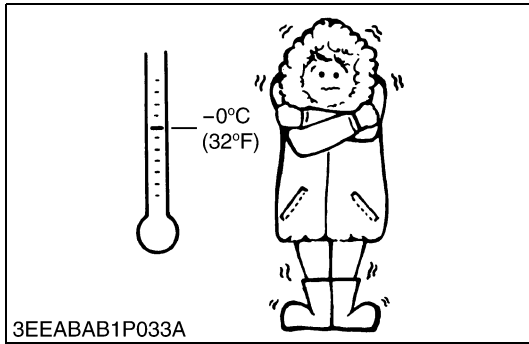

Anti-Freeze

- There are two types of anti-freeze available: use the permanent type (PT) for this engine.
- Before adding anti-freeze for the first time, clean the radiator interior by pouring fresh, soft water and draining it a few times.
- The procedure for mixing water and anti-freeze differs according to the maker of the anti-freeze and the ambient temperature. Basically, it should be referred to SAE J1034 standard, more specifically also to SAE J814c.
- Mix the anti-freeze with fresh, soft water, and then fill into the radiator.

IMPORTANT

- **When the anti-freeze is mixed with fresh, soft water, the anti-freeze mixing ratio must be less than 50 %.**

Vol % anti-freeze	Freezing point		Boiling point*	
	°C	°F	°C	°F
40	-24	-11	106	223
50	-37	-35	108	226

* At 1.013 × 100000 Pa (760 mmHg) pressure (atmospheric). A higher boiling point is obtained by using a radiator pressure cap which permits the development of pressure within the cooling system.

NOTE

- The above data represents industrial standards that necessitate a minimum glycol content in the concentrated anti-freeze.
- When the coolant level drops due to evaporation, add fresh, soft water only to keep the anti-freeze mixing ratio less than 50 %. In case of leakage, add anti-freeze and fresh, soft water in the specified mixing ratio.
- Anti-freeze absorbs moisture. Keep unused anti-freeze in a tightly sealed container.
- Do not use radiator cleaning agents when anti-freeze has been added to the coolant.
(Anti-freeze contains an anti-corrosive agent, which will react with the radiator cleaning agent forming sludge which will affect the engine parts.)

9Y1210785GEG0025US0

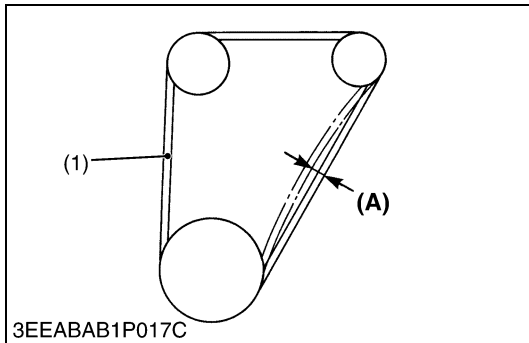

Replacing Fan Belt

1. Remove the alternator.
2. Remove the fan belt (1).
3. Replace new fan belt.
4. Install the alternator.
5. Check the fan belt tension.

Deflection (A)	Factory specification	7.0 to 9.0 mm / 98 N 0.28 to 0.35 in. / 98 N (10 kgf, 22 lbf)
----------------	-----------------------	---

(1) Fan Belt

(A) Deflection

9Y1210785GEG0026US0

[10] CHECK POINTS OF EVERY 1 OR 2 MONTHS

Recharging



CAUTION

- When the battery is being activated, hydrogen and oxygen gases in the battery are extremely explosive. Keep open sparks and flames away from the battery at all times, especially when charging the battery.
- When charging battery, remove battery vent plugs.
- When disconnecting the cable from the battery, start with the negative terminal first. When connecting the cable to the battery, start with the positive terminal first.
- Never check battery charge by placing a metal object across the posts.

Use a voltmeter or hydrometer.

1) Slow Charging

1. Add distilled water if the electrolyte level is low. When charging, the amount of electrolyte should be slightly lower than the specified level to prevent overflow.
2. Connect the battery to the charging unit, following the manufacture's instructions.
3. As the electrolyte generates gas while charging, remove all port caps.
4. The electrolyte temperature must not exceed 40 °C (104 °F) during charging.
If it exceed 40 °C (104 °F), decrease the charging amperage or stop charging for a while.
5. When charging several batteries in series, charging at the rate of the smallest battery in the line.

2) Quick Charging

1. Determine the proper charging current and charging time with the tester attached to the quick charger.
2. Determine the proper charging current as 1/1 of the battery capacity. If the battery capacity exceeds 50 Ah, consider 50 A as the maximum.

■ Precaution for Operating a Quick Charger

- Operating with a quick charger differs according to the type. Consult the instruction manual and use accordingly.

9Y1210785GEG0027US0

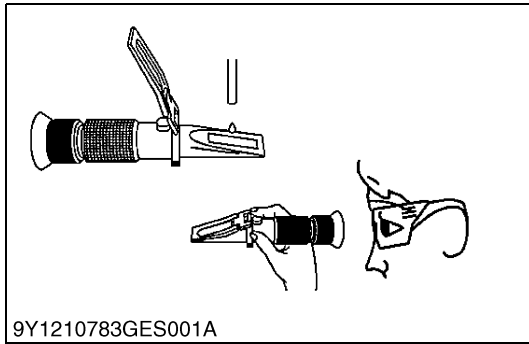

Battery Specific Gravity

⚠ CAUTION

- If battery acid (dilute sulfuric acid) gets on you it could cause blindness or burns, or could cause corrosion of machinery and tools so please be careful when handling.
- Wear safety glasses and rubber gloves when performing battery maintenance and inspection (measuring specific gravity, replenishing water, or charging).
- If the gas that is generated is ignited by an ignition source, it may explode so be very careful with sparks and fire.
- Keep your body and face as far away from the battery as you can when performing maintenance and inspection.
- Do not allow people who do not know how to handle a battery or who do not sufficiently understand the danger perform inspection or maintenance.

(Measurement items)

■ Zero adjustment

1. Open the cover and drip water on the prism surface using the included rod.
2. Close the cover.
3. Aim in a direction that is bright, look into the lens, and adjust the focus until the gradations can be seen clearly.
4. If the boundary line is not on the gradation baseline (0 position), turn the adjustment screw until it matches.
5. When zero adjustment is complete, wipe the prism and cover surface with a soft cloth or tissue paper.

■ Measurement of test fluid

1. Open the cover and drip test fluid on the prism surface using the included rod.
2. Close the cover.
3. Aim in a direction that is bright, look into the lens and read the gradation of the blue boundary line.
4. When the measurement is complete, wipe the prism and cover surface with a soft cloth or tissue paper.

(Reference)

Electrolyte specific gravity and amount of discharge. Use the following table as a reference.

(A) Electrolyte Specific Gravity	(C) Good
(B) Discharge	(D) Charging is necessary.

■ NOTE

Temperature conversion of electrolyte specific gravity

- Battery electrolyte specific gravity changes based on temperature.
- Insert the value identified on a specific gravity meter into the following conversion equation for temperature correction to learn an accurate specific gravity value. (Standard temperature assumed to be 20 °C (68 °F))

$$D_{20} = D_t + 0.0007 (t - 20)$$

$$D_{20} = \text{specific gravity value converted to standard temperature of } 20 \text{ } ^\circ\text{C (68 } ^\circ\text{F)}$$

$$D_t = \text{measured specific gravity value at the electrolyte temperature } t \text{ } ^\circ\text{C}$$

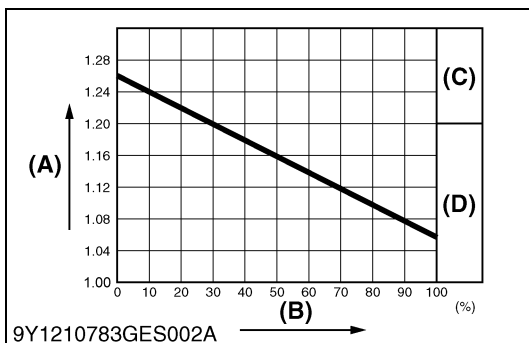

9Y1210785GEG0028US0

[11] CHECK POINT OF EVERY YEAR

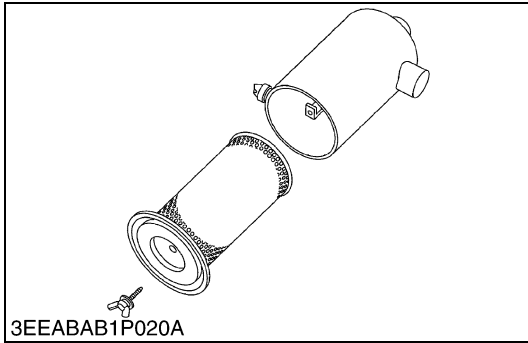

Replacing Air Cleaner Element

1. Remove used air cleaner element.
2. Replace new air cleaner element.

■ NOTE

- The air cleaner uses a dry element. Never apply oil to it.
- Do not run the engine with filter element removed.

9Y1210785GEG0029US0

[12] CHECK POINT OF EVERY 800 HOURS

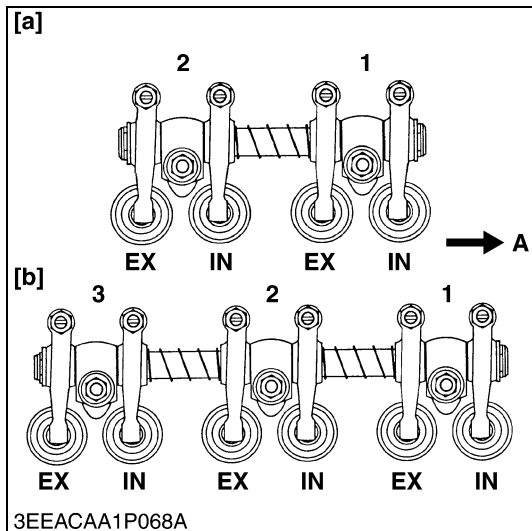
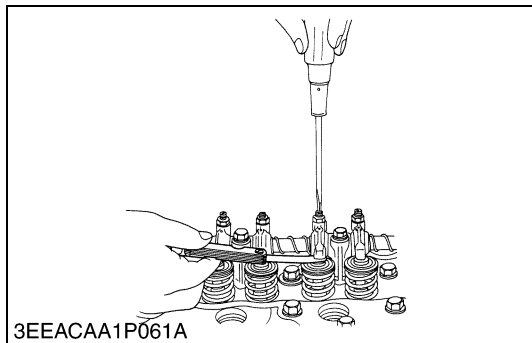
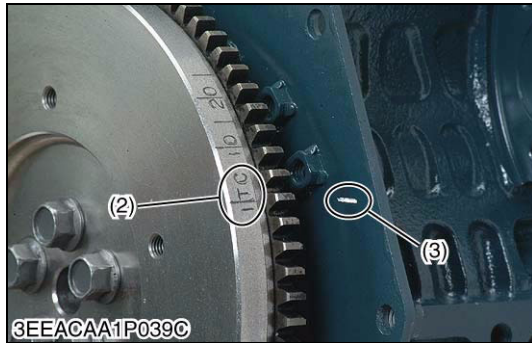
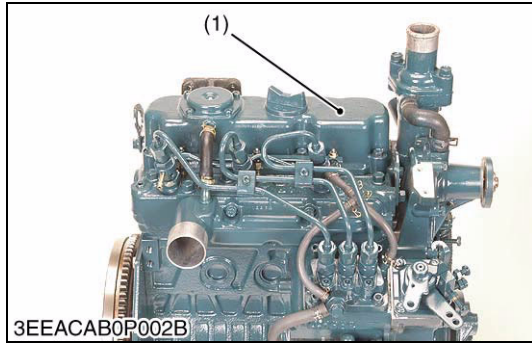

Checking Valve Clearance

■ IMPORTANT

- Valve clearance must be checked and adjusted when engine is cold.
1. Remove the cylinder head cover (1) and the glow plugs.
 2. Align the "1TC" mark (2) on the flywheel and alignment mark (3) on the rear end plate so that the No. 1 piston comes to the compression top dead center.
 3. Check the following valve clearance marked with "★" using a feeler gauge.
 4. If the clearance is not within the factory specifications, adjust with the adjusting screw.
 5. Then turn the flywheel 6.28 rad (360 °), and align the "1TC" mark (2) on the flywheel and alignment mark (3) on the rear end plate so that the No. 1 piston comes to the overlap position.
 6. Check the following valve clearance marked with "☆" using a feeler gauge.
 7. If the clearance is not within the factory specifications, adjust with the adjusting screw.

Adjustable cylinder location of piston	Number of cylinders Valve arrangement			
	Z482-E4B Z602-E4B		D722-E4B D782-E4B D902-E4B	
	Intake valve	Exhaust valve	Intake valve	Exhaust valve
No.1	★	★	★	★
No.2	☆	★	☆	★
No.3	—	—	★	☆

★ : When No. 1 piston is at the compression top dead center position.

☆ : When No. 1 piston is at the overlap position.

Intake and exhaust valve clearance (cold)	Factory specification	0.145 to 0.185 mm 0.00571 to 0.00728 in.
---	-----------------------	---

■ NOTE

- The sequence of cylinder numbers is given as No. 1, No. 2 and No. 3 starting from the gear case side.
- After adjusting the valve clearance, secure the adjusting screw with the lock nut.

- (1) Cylinder Head Cover
- (2) "1TC" Mark
- (3) Alignment Mark

- A: Gear Case Side
- [a] Z482-E4B, Z602-E4B
- [b] D722-E4B, D782-E4B, D902-E4B

9Y1210785GEG0030US0

[13] CHECK POINTS OF EVERY 1500 HOURS

CAUTION

- Check the injection pressure and condition after confirming that there is nobody standing in the direction the fume goes.
- If the fume from the nozzle directly contacts the human body, cells may be destroyed and blood poisoning may be caused.

9Y1210785GEG0031US0

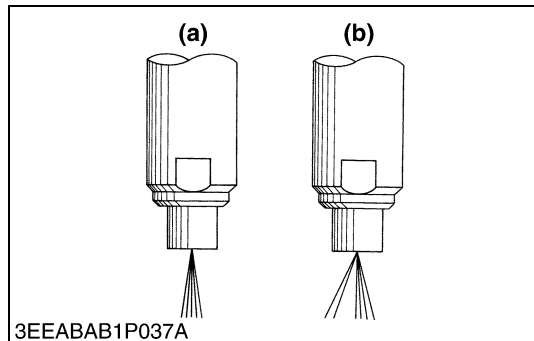

Nozzle Spraying Condition

1. Set the injection nozzle to a nozzle tester, and check the nozzle spraying condition.
2. If the spraying condition is defective, replace the nozzle piece.

(a) Good

(b) Bad

9Y1210785GEG0032US0

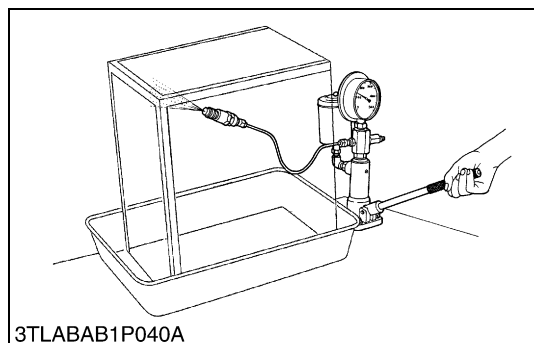

Fuel Injection Pressure

1. Set the injection nozzle to a nozzle tester.
2. Slowly move the tester handle to measure the pressure at which fuel begins jetting out from the nozzle.
3. If the measurement is not within the factory specifications, replace the adjusting washer (1) in the nozzle holder to adjust it.

(Reference)

- Pressure variation with 0.025 mm (0.00098 in.) difference of adjusting washer thickness.
Approx. 590 kPa (6.0 kgf/cm², 85 psi)

Fuel injection pressure	Factory specification	13.73 to 14.70 MPa 140.0 to 150.0 kgf/cm ² 1992 to 2133 psi
-------------------------	-----------------------	--

(1) Adjusting Washer

9Y1210785GEG0033US0

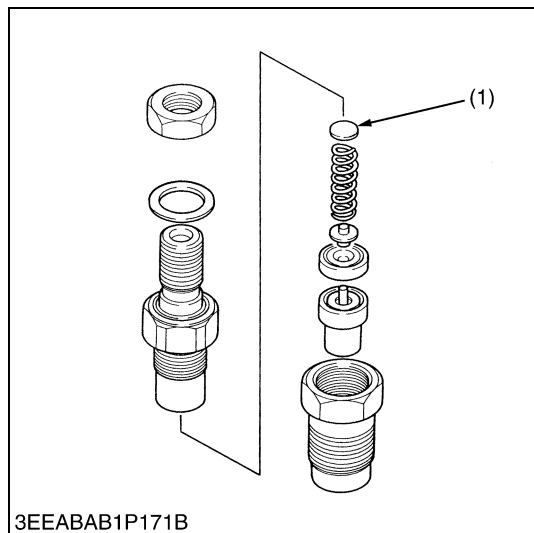

Nozzle Valve Seat Tightness

1. Set the injection nozzle to a nozzle tester.
2. Raise the fuel pressure, and keep at 12.75 MPa (130.0 kgf/cm², 1849 psi) for 10 seconds.
3. If any fuel leak is found, replace the nozzle piece.

Valve seat tightness	Factory specification	No fuel leak at 12.75 MPa 130.0 kgf/cm ² 1849 psi
----------------------	-----------------------	---

9Y1210785GEG0034US0

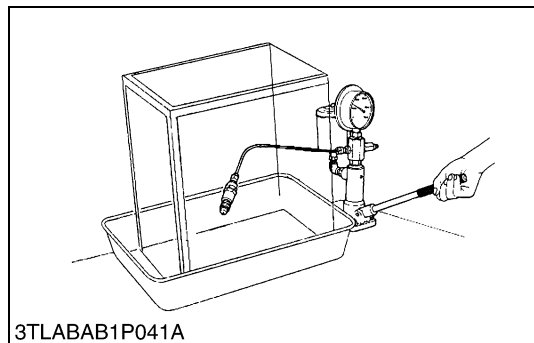

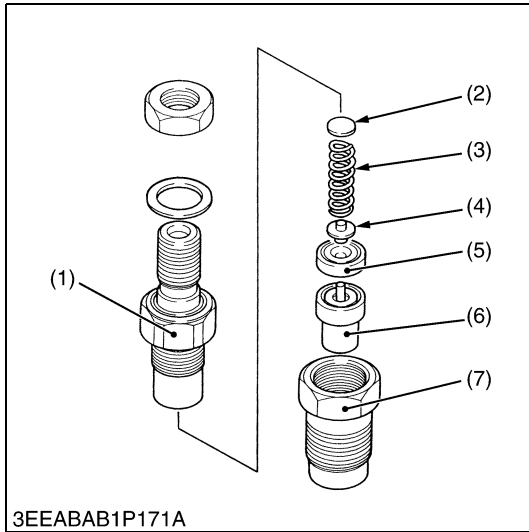

Nozzle Holder

1. Secure the nozzle retaining nut (7) with a vise.
2. Remove the nozzle holder (1), and take out parts inside.

(When reassembling)

- Assemble the nozzle in clean fuel oil.
- Install the push rod (4), noting its direction.
- After assembling the nozzle, be sure to adjust the fuel injection pressure.

Tightening torque	Nozzle holder	35 to 39 N·m 3.5 to 4.0 kgf·m 26 to 28 lbf·ft
	Overflow pipe retaining nut	20 to 24 N·m 2.0 to 2.5 kgf·m 15 to 18 lbf·ft
	Nozzle holder assembly	49 to 68 N·m 5.0 to 7.0 kgf·m 37 to 50 lbf·ft

- | | |
|----------------------|--------------------------|
| (1) Nozzle Holder | (5) Distance Piece |
| (2) Adjusting Washer | (6) Nozzle Piece |
| (3) Nozzle Spring | (7) Nozzle Retaining Nut |
| (4) Push Rod | |

9Y1210785GEG0035US0

[14] CHECK POINTS OF EVERY 3000 HOURS

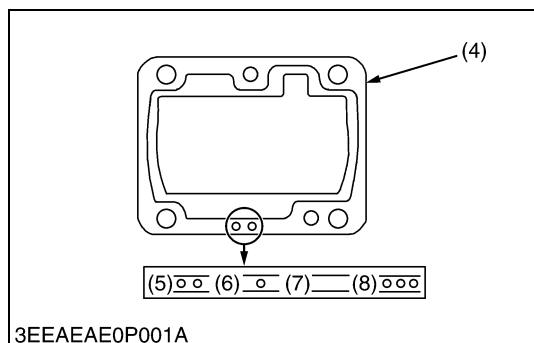
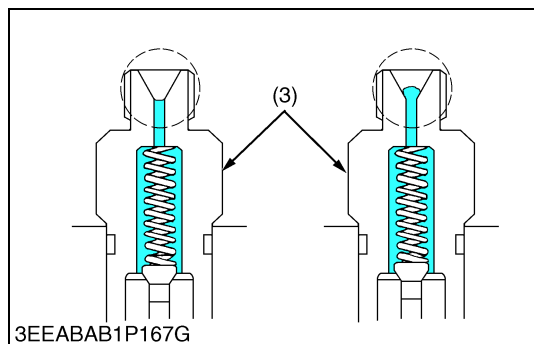
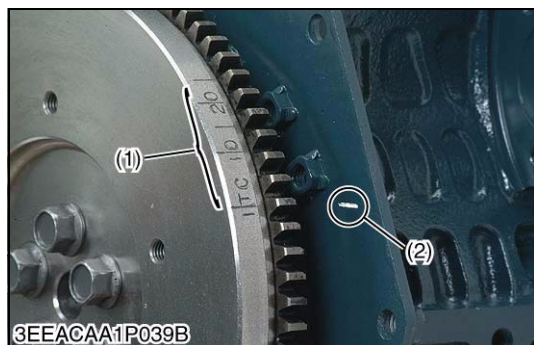

Injection Timing

1. Remove the injection pipes.
2. Remove the engine stop solenoid.
3. Turn the flywheel counterclockwise (viewed from flywheel side) until the fuel fills up to the hole of the delivery valve holder (3) for No. 1 cylinder.
4. After the fuel fills up to the hole of the delivery valve holder for No. 1 cylinder, turn back (clockwise) the flywheel around 1.6 rad (90 °).
5. Turn the flywheel counterclockwise to set at around 0.44 rad (25 °) before T.D.C..
6. Slowly turn the flywheel counterclockwise and stop turning when the fuel begins to come up, to get the present injection timing.
7. Check to see the degree on flywheel.
The flywheel has mark "1TC", "10" and "20" for the crank angle before the top dead center of No. 1 cylinder.
8. Check to see if the timing angle on the flywheel is aligned with the alignment mark (2).
9. If injection timing is out of adjustment, readjust the timing with shims.

Z482/D602-E4B (3600 min⁻¹ (rpm) spec.)

Injection timing	Factory specification	0.3186 to 0.3447 rad (18.25 to 19.75 °) before T.D.C.
------------------	-----------------------	---

D722-E4B (3200 min⁻¹ (rpm) spec.)

Injection timing	Factory specification	0.3360 to 0.3621 rad (19.25 to 20.75 °) before T.D.C.
------------------	-----------------------	---

D782-E4B (3200 min⁻¹ (rpm) spec.)

Injection timing	Factory specification	0.2837 to 0.3097 rad (16.25 to 17.75 °) before T.D.C.
------------------	-----------------------	---

D902-E4B (3600 min⁻¹ (rpm) spec.)

Injection timing	Factory specification	0.3186 to 0.3447 rad (18.25 to 19.75 °) before T.D.C.
------------------	-----------------------	---

- | | |
|-----------------------------------|--|
| (1) Timing Line | (5) Two-holes : 0.20 mm (0.0079 in.) |
| (2) Alignment Mark | Two-holes : 0.175 mm (0.00689 in.) |
| (3) Delivery Valve Holder | (6) One-hole : 0.25 mm (0.0098 in.) |
| (4) Shim (Soft Metal Gasket Shim) | (7) Without hole : 0.30 mm (0.012 in.) |
| | (8) Three-holes : 0.35 mm (0.014 in.) |

(To be continued)

(Continued)

■ **NOTE**

- The liquid gasket is not required for assembling.
- Shims are available in thickness of 0.20 mm (0.0079 in.), 0.25 mm (0.0098 in.), 0.30 mm (0.012 in.), 0.35 mm (0.014 in.) and 0.175 mm (0.00689 in.). Combine these shims for adjustments.
- Addition or reduction of shim (0.025 mm, 0.00098 in.) delays or advances the injection timing by approx. 0.0044 rad (0.25 °).
- In disassembling and replacing the injection pump, be sure to use the same number of new shims with the same thickness.
- The 0.175 mm (0.00689 in.) thick shim is coated only on the lower face. Therefore, do not use the 0.175 mm (0.00689 in.) thick shim as the top shim of the combination (injection pump side), because this can cause oil leakage.
- Refer to figure of the shim to check the thickness of the shims.
- The injection timing might be changed by the application.

9Y1210785GEG0036US0

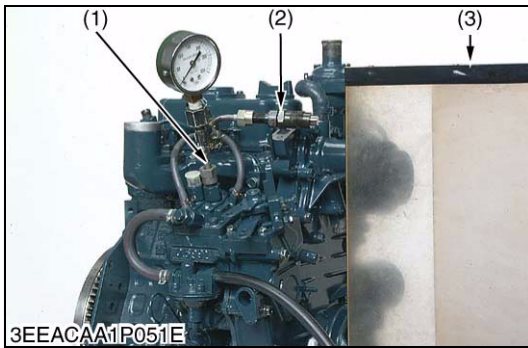

Checking Injection Pump

(Fuel Tightness of Pump Element)

1. Remove the engine stop solenoid.
2. Remove the injection pipes and glow plugs.
3. Install the injection pump pressure tester to the injection pump.
4. Install the injection nozzle (2) jetted with the proper injection pressure to the injection pump pressure tester (1). (Refer to the photo.)
5. Set the speed control lever to the maximum speed position.
6. Run the starter to increase the pressure.
7. If the pressure can not reach the allowable limit, replace the pump with new one or repair with a KUBOTA-authorized pump service shop.

(Fuel Tightness of Delivery Valve)

1. Remove the engine stop solenoid.
2. Remove the injection pipes and glow plugs.
3. Set a pressure tester to the fuel injection pump.
4. Install the injection nozzle (2) jetted with the proper injection pressure to the injection pump pressure tester (1).
5. Run the starter to increase the pressure.
6. Stop the starter when the fuel jets from the injection nozzle. After that, turn the flywheel by hands and raise the pressure to approx. 13.73 MPa (140.0 kgf/cm², 1991 psi).
7. Now turn the flywheel back about half a turn (to keep the plunger free). Maintain the flywheel at this position and clock the time taken for the pressure to drop from 13.73 to 12.75 MPa (from 140.0 to 130.0 kgf/cm², from 1991 to 1849 psi).
8. Measure the time needed to decrease the pressure from 13.73 to 12.75 MPa (140.0 to 130.0 kgf/cm², 1991 to 1849 psi).
9. If the measurement is less than allowable limit, replace the pump with new one or repair with a KUBOTA-authorized pump service shop.

Fuel tightness of pump element	Allowable limit	13.73 MPa 140.0 kgf/cm ² 1991 psi
Fuel tightness of delivery valve	Factory specification	10 seconds 13.73 → 12.75 MPa 140.0 → 130.0 kgf/cm ² 1991 → 1849 psi
	Allowable limit	5 seconds 13.73 → 12.75 MPa 140.0 → 130.0 kgf/cm ² 1991 → 1849 psi

■ NOTE

- **Never try to disassemble the injection pump assembly. For repairs, you are strongly requested to contact a KUBOTA-authorized pump service shop.**

- (1) Injection Pump Pressure Tester (3) Protection Cover for Jetted Fuel
(2) Injection Nozzle

9Y1210785GEG0037US0

[15] CHECK POINTS OF EVERY 2 YEARS

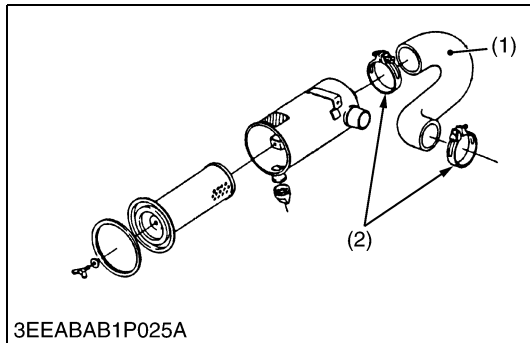

Replacing Intake Air Line

1. Loosen the clamp (2).
2. Remove the intake air hose (1) and clamp (2).
3. Replace new intake air hose (1) and new clamp (2).
4. Tighten the clamp (2).

■ NOTE

- To prevent serious damage to the engine, keep out any dust inside the intake air line.

(1) Intake Air Hose

(2) Clamp

9Y1210785GEG0038US0

Replacing Battery

⚠ CAUTION

- When the battery is being activated, hydrogen and oxygen gases in the battery are extremely explosive. Keep open sparks and flames away from the battery at all times, especially when charging the battery.
- When charging battery, remove battery vent plugs.
- When disconnecting the cable from the battery, start with the negative terminal first. When connecting the cable to the battery, start with the positive terminal first.
- Never check battery charge by placing a metal object across the posts.

1. Disconnect the negative terminal and positive terminal.
2. Remove the battery holder.
3. Remove the used battery.
4. Replace the new battery.
5. Tighten the battery holder.
6. Connect the positive terminal.
7. Connect the negative terminal.

9Y1210785GEG0039US0

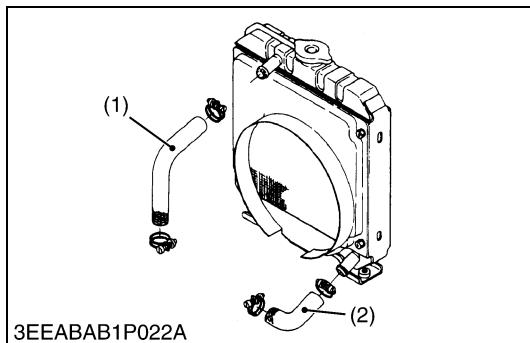

Replacing Radiator Hoses and Clamp Bands

⚠ CAUTION

- Do not remove the radiator cap when the engine is hot. Then loosen cap slightly to the stop to relieve any excess pressure before removing cap completely.

1. Drain the coolant.
2. Loosen the clamp bands.
3. Remove the upper hose (1) and lower hose (2).
4. Replace new upper / lower hose (1), (2) and clamp bands.
5. Tighten the clamp bands.
6. Fill with clean water and anti-freeze until the coolant level is just below the port. Install the radiator cap securely.

(1) Upper Hose

(2) Lower Hose

9Y1210785GEG0040US0

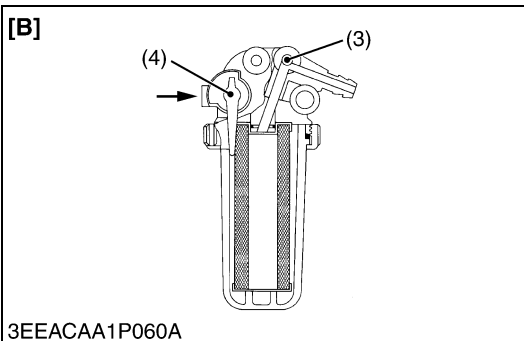
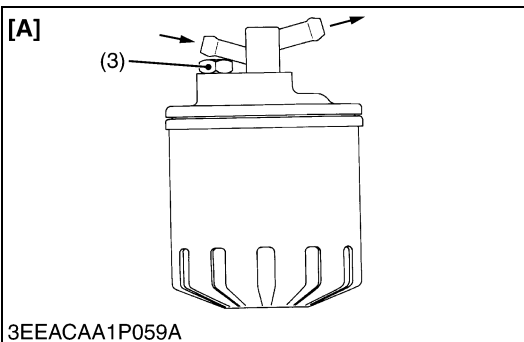
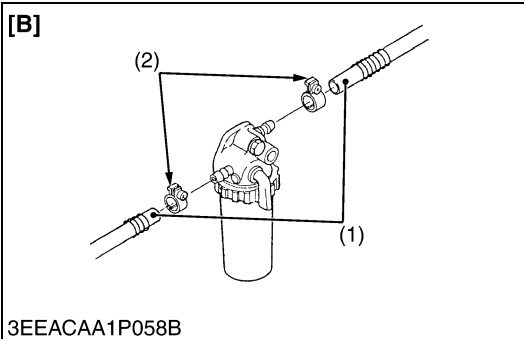
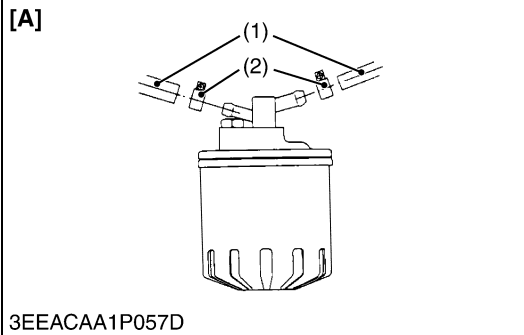

Replacing Fuel Hoses and Clamp Bands

1. Loosen the clamp (2) and remove the fuel hose (1).
2. Replace new fuel hose (1) and new clamp (2).
3. Tighten the clamp (2).



CAUTION

- Stop the engine when attempting the check and change prescribed above.

(When bleeding fuel system)

1. Fill the tank with fuel and open the cock (4). ([B] only.)
2. Loosen the air vent plug (3) of the fuel filter a few turns.
3. Screw back the plug when bubbles do not come up any more.
4. Open the air vent cock on top of the fuel injection pump.
5. If equipped electrical fuel feed pump, turn the key to **AC** position and pump the fuel up for 10 to 15 seconds.
If equipped mechanical fuel feed pump, set the stop lever on stop position and crank the engine for 10 to 15 seconds.
6. Close securely the air vent cock after air bleeding.

NOTE

- Always keep the air vent cock on the fuel injection pump closed except when air is vented, or it may cause the engine to stop.

- (1) Fuel Hose
(2) Clamp
(3) Air Vent Plug
(4) Fuel Cock

[A] Cartridge Type

[B] Element Type

9Y1210785GEG0041US0

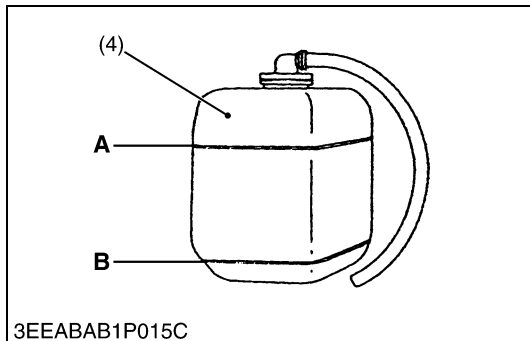
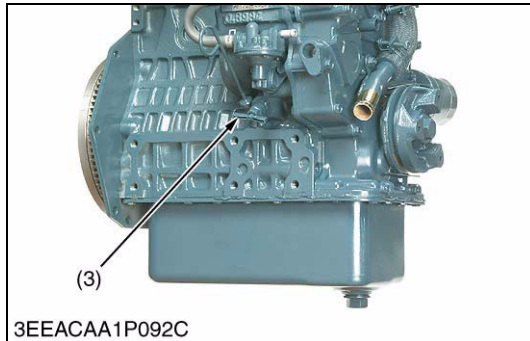
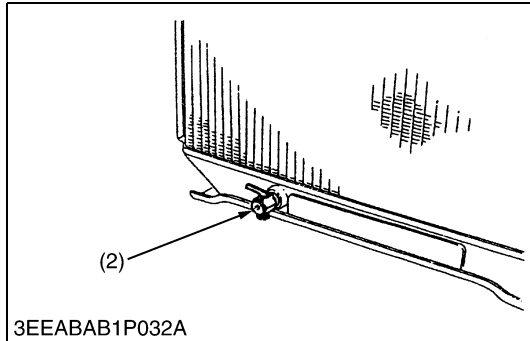
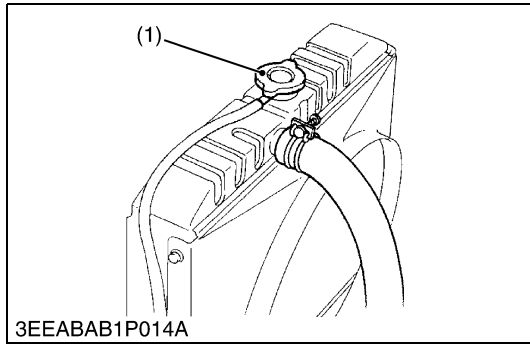

Cleaning Water Jacket and Radiator Interior

⚠ CAUTION

- **Do not remove the radiator cap when the engine is hot. Then loosen cap slightly to the stop to relieve any excess pressure before removing cap completely.**
1. Stop the engine and let cool down.
 2. To drain the coolant, open the radiator drain plug (2) and remove the radiator cap (1). Then radiator cap (1) must be removed to completely drain the coolant. And open the drain cock (3).
 3. After all coolant is drained, close the drain plug.
 4. Fill with clean water and cooling system cleaner.
 5. Follow directions of the cleaner instruction.
 6. After flushing, fill with clean water and anti-freeze until the coolant level is just below the port. Install the radiator cap (1) securely.
 7. Fill with coolant up to "**FULL**" (A) mark on the recovery tank (4).
 8. Start and operate the engine for few minutes.
 9. Stop the engine and let cool. Check coolant level of radiator and recovery tank (4) and add coolant if necessary.

■ IMPORTANT

- **Do not start engine without coolant.**
- **Use clean, fresh, soft water and anti-freeze to fill the radiator and recovery tank.**
- **When the anti-freeze is mixed with fresh, soft water, the anti-freeze mixing ratio must be less than 50 %.**
- **Securely tighten radiator cap. If the cap is loose or improperly fitted, water may leak out and the engine could overheat.**

- (1) Radiator Cap
 (2) Drain Plug
 (3) Drain Cock
 (4) Recovery Tank

A : Full
 B : Low

(To be continued)

(Continued)

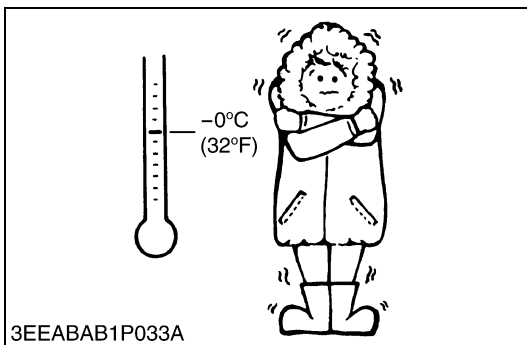
**(Anti-freeze)**

- There are two types of anti-freeze available: use the permanent type (PT) for this engine.
- Before adding anti-freeze for the first time, clean the radiator interior by pouring fresh, soft water and draining it a few times.
- The procedure for mixing water and anti-freeze differs according to the maker of the anti-freeze and the ambient temperature. Basically, it should be referred to SAE J1034 standard, more specifically also to SAE J814c.
- Mix the anti-freeze with fresh, soft water, and then fill into the radiator.

■ IMPORTANT

- **When the anti-freeze is mixed with fresh, soft water, the anti-freeze mixing ratio must be less than 50 %.**

Vol % anti-freeze	Freezing point		Boiling point*	
	°C	°F	°C	°F
40	-24	-11	106	223
50	-37	-35	108	226

* At 1.013×100000 Pa (760 mmHg) pressure (atmospheric). A higher boiling point is obtained by using a radiator pressure cap which permits the development of pressure within the cooling system.

■ NOTE

- **The above data represents industrial standards that necessitate a minimum glycol content in the concentrated anti-freeze.**
- **When the coolant level drops due to evaporation, add fresh, soft water only to keep the anti-freeze mixing ratio less than 50 %. In case of leakage, add anti-freeze and fresh, soft water in the specified mixing ratio.**
- **Anti-freeze absorbs moisture. Keep unused anti-freeze in a tightly sealed container.**
- **Do not use radiator cleaning agents when anti-freeze has been added to the coolant.**
(Anti-freeze contains an anti-corrosive agent, which will react with the radiator cleaning agent forming sludge which will affect the engine parts.)

9Y1210785GEG0042US0

5. SPECIAL TOOLS

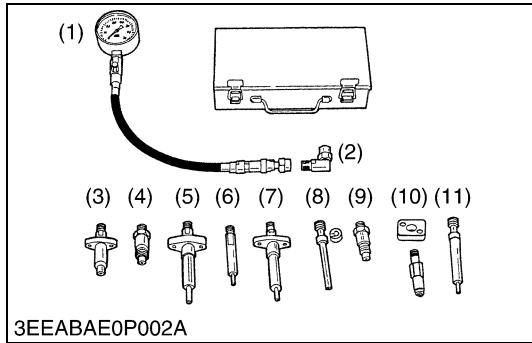

Diesel Engine Compression Tester (for Injection Nozzle)

Code No.

- 07909-30208 (Assembly)
- 07909-30934 (A to F)
- 07909-31211 (E and F)
- 07909-31231 (H)
- 07909-31251 (G)
- 07909-31271 (I)
- 07909-31281 (J)

Application

- Use to measure diesel engine compression and diagnostics of need for major overhaul.

- | | |
|---------------|----------------|
| (1) Gauge | (7) Adaptor F |
| (2) L Joint | (8) Adaptor G |
| (3) Adaptor A | (9) Adaptor H |
| (4) Adaptor B | (10) Adaptor I |
| (5) Adaptor C | (11) Adaptor J |
| (6) Adaptor E | |

WSM000001GEG0014US0

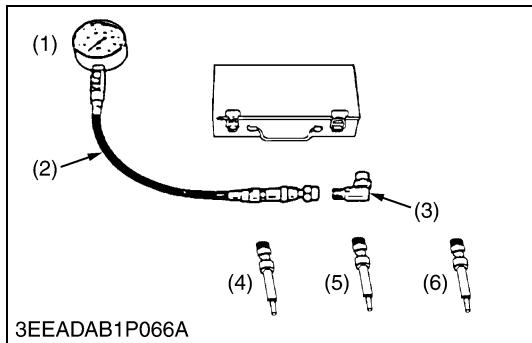

Diesel Engine Compression Tester (for Glow Plug)

Code No.

- 07909-39081 (Assembly)
- 07909-31291 (K)
- 07909-31301 (L)
- 07909-31311 (M)

Application

- Use to measure diesel engine compression and diagnosis of need for major overhaul.

- | | |
|-------------------|---------------|
| (1) Gauge | (4) Adaptor K |
| (2) Hose Assembly | (5) Adaptor L |
| (3) L Joint | (6) Adaptor M |

WSM000001GEG0096US0

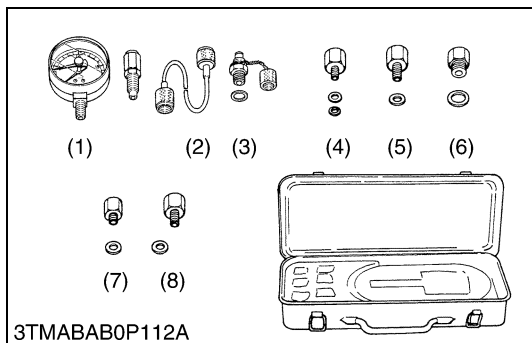

Oil Pressure Tester

Code No.

- 07916-32032

Application

- Use to measure lubricating oil pressure.

- | | |
|--------------------|---------------|
| (1) Gauge | (5) Adaptor 2 |
| (2) Cable | (6) Adaptor 3 |
| (3) Threaded Joint | (7) Adaptor 4 |
| (4) Adaptor 1 | (8) Adaptor 5 |

WSM000001GEG0015US0

■ **NOTE**

- The following special tools are not provided, so make them referring to the figure.

9Y1210785GEG0043US0

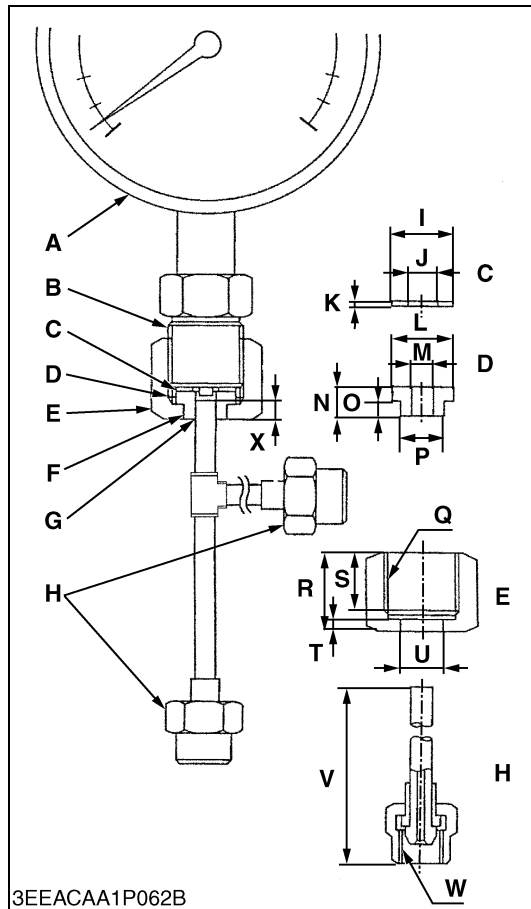

Injection Pump Pressure Tester

Application

- Use to check fuel tightness of injection pumps.

A	Pressure gauge full scale : More than 29.4 MPa (300 kgf/cm ² , 4270 psi)
B	PF 1/2
C	Copper gasket
D	Flange (Material Steel)
E	Hex. nut 27 mm (1.1 in.) across the plat
F	Adhesive application
G	Fillet welding on the enter circumference
H	Retaining nut
I	17 mm dia. (0.67 in. dia.)
J	8.0 mm dia. (0.31 in. dia.)
K	1.0 mm (0.039 in.)
L	17 mm dia. (0.67 in. dia.)
M	6.10 to 6.20 mm dia. (0.241 to 0.244 in. dia.)
N	8.0 mm (0.31 in.)
O	4.0 mm (0.16 in.)
P	11.97 to 11.99 mm dia. (0.4713 to 0.4720 in. dia.)
Q	PF 1/2
R	23 mm (0.91 in.)
S	17 mm (0.67 in.)
T	4.0 mm (0.16 in.)
U	12.00 to 12.02 mm dia. (0.4725 to 0.4732 in. dia.)
V	100 mm (3.94 in.)
W	M12 × P1.5
X	5.0 mm (0.20 in.)

9Y1210785GEG0044US0

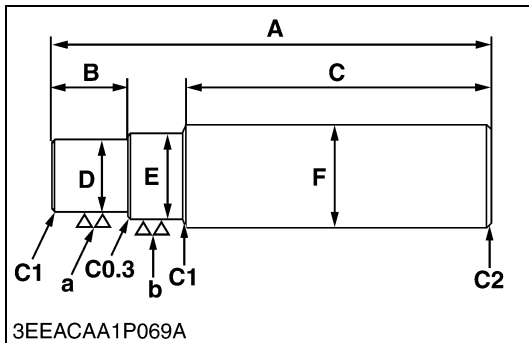
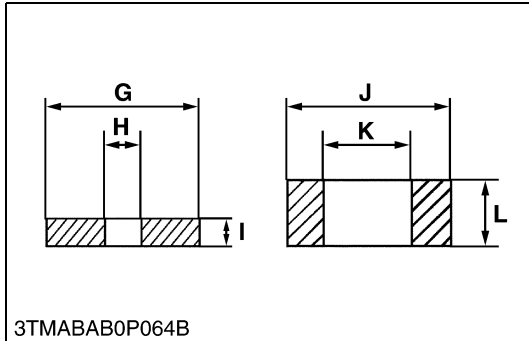
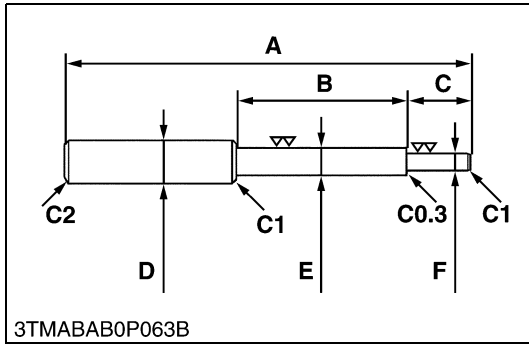

Valve Guide Replacing Tool

Application

- Use to press out and press fit the valve guide.

A	220 mm (8.66 in.)
B	80 mm (3.1 in.)
C	40 mm (1.6 in.)
D	20 mm dia. (0.79 in. dia.)
E	9.960 to 9.980 mm dia. (0.3922 to 0.3929 in. dia.)
F	5.50 to 5.70 mm dia. (0.217 to 0.224 in. dia.)
G	25 mm dia. (0.98 in. dia.)
H	6.00 to 6.10 mm dia. (0.237 to 0.240 in. dia.)
I	5.0 mm (0.20 in.)
J	18 mm dia. (0.71 in. dia.)
K	10.6 to 10.7 mm dia. (0.418 to 0.421 in. dia.)
L	6.90 to 7.10 mm (0.272 to 0.279 in.)
C1	Chamfer 1.0 mm (0.039 in.)
C2	Chamfer 2.0 mm (0.079 in.)
C0.3	Chamfer 0.3 mm (0.01 in.)

9Y1210785GEG0045US0

Bushing Replacing Tool

Application

- Use to press out and press fit the bushing.

■ For small end bushing

A	145 mm (5.71 in.)
B	20 mm (0.79 in.)
C	100 mm (3.94 in.)
D	19.90 to 19.95 mm dia. (0.7835 to 0.7854 in. dia.)
E	21.90 to 21.95 mm dia. (0.8622 to 0.8641 in. dia.)
F	25 mm dia. (0.98 in. dia.)
C1	Chamfer 1.0 mm (0.039 in.)
C2	Chamfer 2.0 mm (0.079 in.)
C0.3	Chamfer 0.3 mm (0.01 in.)
a	6.3 μm (250 μin.)
b	6.3 μm (250 μin.)

■ For idle gear bushing

A	150 mm (5.91 in.)
B	23 mm (0.91 in.)
C	100 mm (3.94 in.)
D	19.90 to 19.95 mm dia. (0.7835 to 0.7854 in. dia.)
E	21.90 to 21.95 mm dia. (0.8622 to 0.8641 in. dia.)
F	25 mm dia. (0.98 in. dia.)
C1	Chamfer 1.0 mm (0.039 in.)
C2	Chamfer 2.0 mm (0.079 in.)
C0.3	Chamfer 0.3 mm (0.01 in.)
a	6.3 μm (250 μin.)
b	6.3 μm (250 μin.)

9Y1210785GEG0046US0

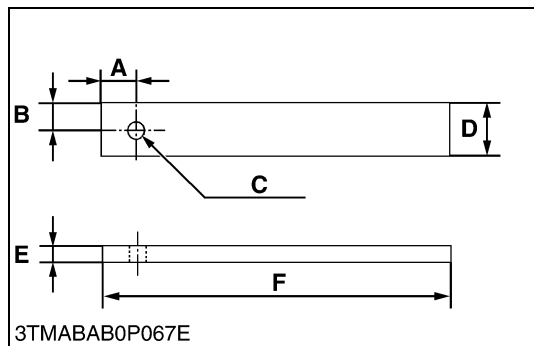

Flywheel Stopper

Application

- Use to loosen and tighten the flywheel screw.

A	20 mm (0.79 in.)
B	15 mm (0.59 in.)
C	10 mm dia. (0.39 in. dia.)
D	30 mm (1.2 in.)
E	8.0 mm (0.31 in.)
F	200 mm (7.87 in.)

9Y1210785GEG0047US0

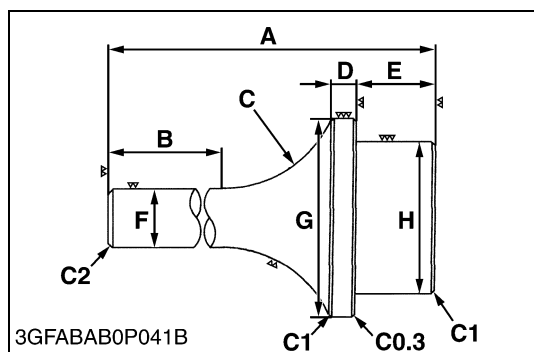

Crankshaft Bearing 1 Replacing Tool

Application

- Use to press out and press fit the crankshaft bearing 1.

■ Press Out

A	135 mm (5.31 in.)
B	72 mm (2.8 in.)
C	40 mm radius (1.6 in. radius)
D	10 mm (0.39 in.)
E	22 mm (0.87 in.)
F	20 mm dia. (0.79 in. dia.)
G	47.90 to 47.95 mm dia. (1.886 to 1.887 in. dia.)
H	43.90 to 43.95 mm dia. (1.729 to 1.730 in. dia.)
C1	Chamfer 1.0 mm (0.039 in.)
C2	Chamfer 2.0 mm (0.079 in.)
C0.3	Chamfer 0.3 mm (0.01 in.)

■ Press Fit for Z482/D722-E4B, D782-E4B

A	130 mm (5.12 in.)
B	72 mm (2.8 in.)
C	40 mm radius (1.6 in. radius)
D	9.0 mm (0.35 in.)
E	24 mm (0.94 in.)
F	20 mm dia. (0.79 in. dia.)
G	68 mm dia. (2.7 in. dia.)
H	39.90 to 39.95 mm dia. (1.571 to 1.572 in. dia.)
C1	Chamfer 1.0 mm (0.039 in.)
C2	Chamfer 2.0 mm (0.079 in.)
C0.3	Chamfer 0.3 mm (0.01 in.)

■ Press Fit for Z602/D902-E4B

A	130 mm (5.12 in.)
B	72 mm (2.8 in.)
C	40 mm radius (1.6 in. radius)
D	9.0 mm (0.35 in.)
E	24 mm (0.94 in.)
F	20 mm dia. (0.79 in. dia.)
G	68 mm dia. (2.7 in. dia.)
H	43.90 to 43.95 mm dia. (1.729 to 1.730 in. dia.)
C1	Chamfer 1.0 mm (0.039 in.)
C2	Chamfer 2.0 mm (0.079 in.)
C0.3	Chamfer 0.3 mm (0.01 in.)

9Y1210785GEG0048US0

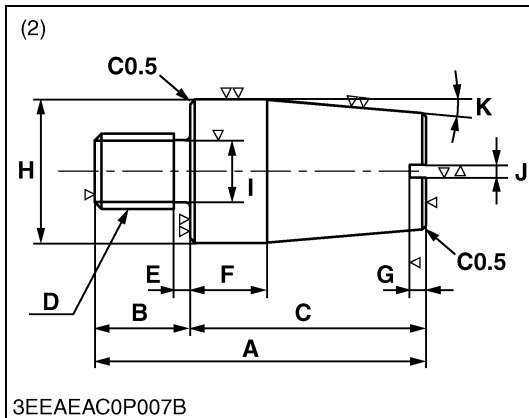
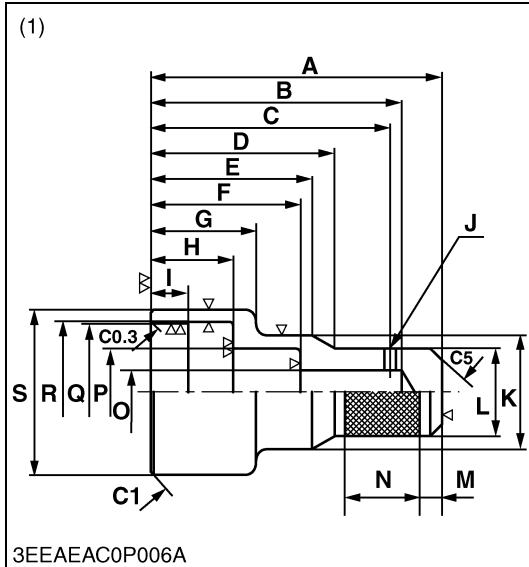
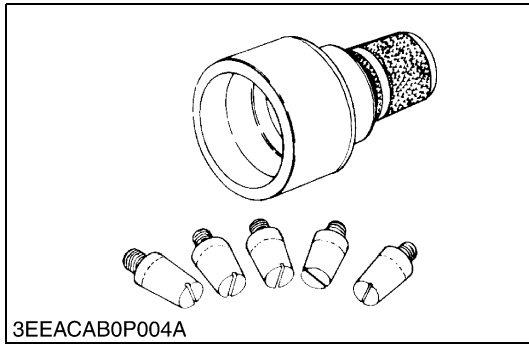

Crank Sleeve Setter (for Z482/D722-E4B, D782-E4B)

Application

- Use to fix the crankshaft sleeve.

(1) Auxiliary Socket for Pushing

A	130 mm (5.12 in.)
B	112 mm (4.41 in.)
C	107 mm (4.21 in.)
D	82 mm (3.2 in.)
E	72 mm (2.8 in.)
F	67 mm (2.6 in.)
G	47 mm (1.8 in.)
H	37.00 to 37.20 mm (1.457 to 1.464 in.)
I	17 mm (0.67 in.)
J	5.0 mm dia. (0.20 in. dia.)
K	52 mm dia. (2.0 in. dia.)
L	40 mm dia. (1.6 in. dia.)
M	10 mm (0.39 in.)
N	33 mm (1.3 in.)
O	20 mm dia. (0.79 in. dia.)
P	40 mm dia. (1.6 in. dia.)
Q	63.10 to 63.15 mm dia. (2.485 to 2.486 in. dia.)
R	64 mm dia. (2.5 in. dia.)
S	75 mm dia. (3.0 in. dia.)
C0.3	Chamfer 0.3 mm (0.01 in.)
C1	Chamfer 1.0 mm (0.039 in.)
C5	Chamfer 5.0 mm (0.20 in.)

(2) Sleeve Guide

A	42 mm (1.7 in.)
B	12 mm (0.47 in.)
C	30 mm (1.2 in.)
D	M10 × Pitch 1.25
E	2.0 mm (0.079 in.)
F	10 mm (0.39 in.)
G	2.0 mm (0.079 in.)
H	17.90 to 17.95 mm dia. (0.7048 to 0.7066 in. dia.)
I	8.0 mm dia. (0.31 in. dia.)
J	1.8 mm (0.071 in.)
K	0.09 rad (5 °)
C0.5	Chamfer 0.5 mm (0.02 in.)

9Y1210785GEG0049US0

1 ENGINE

MECHANISM

CONTENTS

1. ENGINE BODY	1-M1
[1] HALF-FLOATING HEAD COVER	1-M1
[2] CLOSED BREATHER	1-M1
[3] PISTON (Z602-E4B, D782-E4B, D902-E4B)	1-M2
[4] OIL PAN (Z602-E4B, D902-E4B)	1-M2
2. COOLING SYSTEM	1-M3
[1] COOLING FIN (Z602-E4B, D902-E4B)	1-M3

1. ENGINE BODY

[1] HALF-FLOATING HEAD COVER

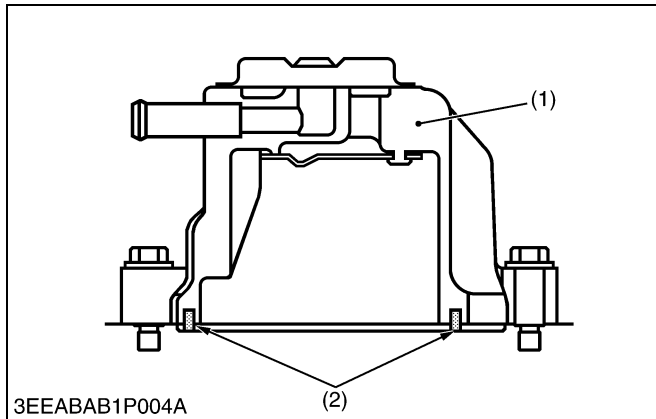

The rubber packing is fitted in to maintain the cylinder head cover 0.5 mm (0.02 in.) or so off the cylinder head. This arrangement helps reduce noise coming from the cylinder head.

- (1) Cylinder Head Cover (2) Rubber Packing

9Y1210785ENM0001US0

[2] CLOSED BREATHER

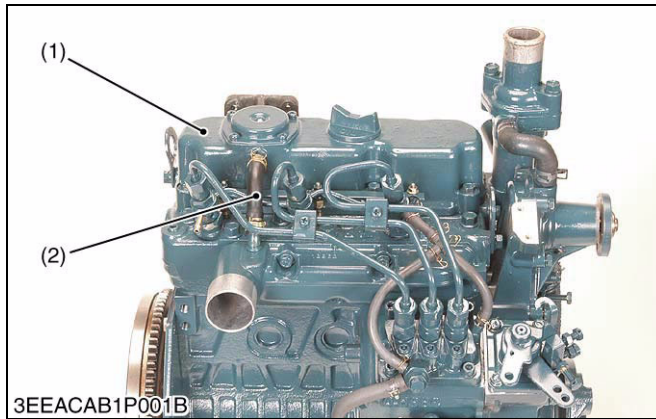

Closed breather system has been adopted to prevent the release of blow-by gas into the atmosphere.

After its oil content is filtered by oil shield (4), the blow-by gas is fed back to the intake manifold through breather valve (3) to be used for re-combustion.

- (1) Cylinder Head Cover (4) Oil Shield
(2) Breather Hose (5) Rubber Packing
(3) Breather Valve

9Y1210785ENM0002US0

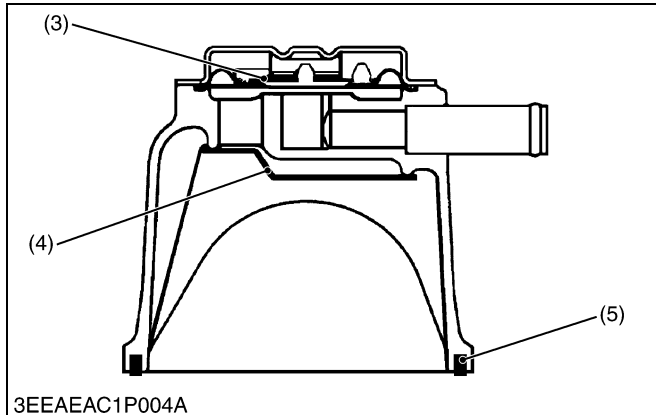

[3] PISTON (Z602-E4B, D782-E4B, D902-E4B)



Piston's skirt is coated with **molybdenum disulfide***, which reduces the piston slap noise and thus the entire operating noise.

*Molybdenum disulfide (MoS₂)

The molybdenum disulfide (1) serves as a solid lubricant, like a Graphite or Teflon. This material helps resist metal wears even with little lube oil.

- (1) Molybdenum Disulfide

9Y1210785ENM0003US0

[4] OIL PAN (Z602-E4B, D902-E4B)



The oil pan is extended under the gear case. Therefore, the height of the engine can be lowered more than so far while securing a necessary amount of oil.

- (1) Cylinder Block (3) Oil Pan
(2) Gear Case

9Y1210785ENM0004US0

2. COOLING SYSTEM

[1] COOLING FIN (Z602-E4B, D902-E4B)

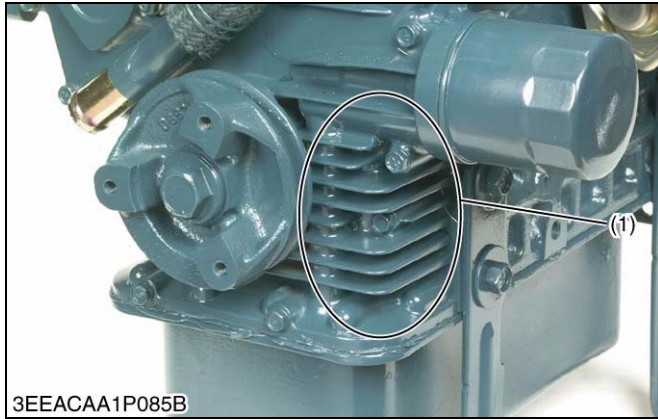

The cooling fin is set up around the oil passage in the gear case.

Therefore, the temperature of oil is decreased by the wind generated by the cooling fan.

(1) Cooling Fin

9Y1210785ENM0005US0

SERVICING

CONTENTS

1. TROUBLESHOOTING.....	1-S1
2. SERVICING SPECIFICATIONS.....	1-S4
3. TIGHTENING TORQUES.....	1-S12
[1] TIGHTENING TORQUES FOR GENERAL USE SCREWS, BOLTS AND NUTS.....	1-S12
[2] TIGHTENING TORQUES FOR SPECIAL USE SCREWS, BOLTS AND NUTS.....	1-S13
4. CHECKING, DISASSEMBLING AND SERVICING.....	1-S14
[1] CHECKING AND ADJUSTING.....	1-S14
(1) Engine Body.....	1-S14
(2) Lubricating System.....	1-S16
(3) Cooling System.....	1-S17
(4) Fuel System.....	1-S19
(5) Electrical System.....	1-S23
[2] DISASSEMBLING AND ASSEMBLING.....	1-S29
(1) Draining Engine Oil and Coolant.....	1-S29
(2) External Components.....	1-S30
(3) Cylinder Head, Valves and Oil Pan.....	1-S30
(4) Gear Case and Timing Gears.....	1-S35
(5) Piston and Connecting Rod.....	1-S41
(6) Flywheel and Crankshaft.....	1-S43
(7) Starter.....	1-S47
(8) Dynamo.....	1-S49
(9) Alternator.....	1-S50
[3] SERVICING.....	1-S51
(1) Cylinder Head and Valves.....	1-S51
(2) Timing Gears.....	1-S56
(3) Piston and Connecting Rod.....	1-S59
(4) Crankshaft.....	1-S61
(5) Cylinder.....	1-S67
(6) Oil Pump.....	1-S68
(7) Starter.....	1-S69
(8) Alternator.....	1-S72

1. TROUBLESHOOTING

Symptom	Probable Cause	Solution	Reference Page
Engine Does Not Start	No fuel	Replenish fuel	G-11
	Air in the fuel system	Bleed	G-11
	Water in the fuel system	Change fuel and repair or replace fuel system	G-11
	Fuel hose clogged	Clean or replace	G-11
	Fuel filter clogged	Replace	G-17
	Excessively high viscosity of fuel or engine oil at low temperature	Use specified fuel or engine oil	I-4, G-6
	Fuel with low cetane number	Use specified fuel	I-4, G-6
	Fuel leak due to loose injection pipe retaining nut	Tighten retaining nut	1-S31
	Incorrect injection timing	Adjust	I-4, G-26
	Fuel camshaft worn	Replace	1-S57
	Injection nozzle clogged	Clean or replace	1-S22
	Injection pump malfunctioning	Repair or replace	G-28, 1-S21
	Seizure of crankshaft, camshaft, piston, cylinder or bearing	Repair or replace	1-S39, 1-S41, 1-S43
	Compression leak from cylinder	Replace head gasket, tighten cylinder head screw, glow plug and nozzle holder	1-S14, 1-S32
	Improper valve timing	Correct or replace timing gear	1-S39
	Piston ring and cylinder worn	Replace	1-S60, 1-S61, 1-S67
	Excessive valve clearance	Adjust	G-23
Stop solenoid malfunctioning	Replace	1-S28, 1-S29	
Starter Does Not Run	Battery discharged	Charge	1-S23, 1-S24
	Starter malfunctioning	Repair or replace	1-S25, 1-S26
	Wiring disconnected	Connect	–

Symptom	Probable Cause	Solution	Reference Page
Engine Revolution Is Not Smooth	Fuel filter clogged or dirty	Replace	G-17
	Air cleaner clogged	Clean or replace	G-14
	Fuel leak due to loose injection pipe retaining nut	Tighten retaining nut	1-S31
	Injection pump malfunctioning	Repair or replace	G-28, 1-S21
	Incorrect nozzle injection pressure	Adjust	G-24
	Injection nozzle stuck or clogged	Repair or replace	G-24
	Governor malfunctioning	Repair	1-S45
Either White or Blue Exhaust Gas Is Observed	Excessive engine oil	Reduce to specified level	I-4, G-7, G-9
	Piston ring and cylinder worn or stuck	Repair or replace	1-S60, 1-S61
	Incorrect injection timing	Adjust	I-4, G-26
Either Black or Dark Gray Exhaust Gas Is Observed	Overload	Reduce the load	I-4
	Low grade fuel used	Use specified fuel	I-4, G-6
	Fuel filter clogged	Replace	G-17
	Air cleaner clogged	Clean or replace	G-14
	Deficient nozzle injection	Repair or replace nozzle	G-24
Deficient Output	Incorrect injection timing	Adjust	I-4, G-26
	Engine's moving parts seem to be seizing	Repair or replace	1-S39, 1-S45
	Injection pump malfunctioning	Repair or replace	G-28, 1-S21
	Deficient nozzle injection	Repair or replace nozzle	G-28
	Compression leak	Check the compression pressure and repair	1-S14, 1-S32
Excessive Lubricant Oil Consumption	Piston ring's gap facing the same direction	Shift ring gap direction	1-S41
	Oil ring worn or stuck	Replace	1-S42
	Piston ring groove worn	Replace piston	1-S61
	Valve stem and valve guide worn	Replace	1-S52
	Crankshaft bearing and crank pin bearing worn	Replace	1-S61, 1-S63
	Oil leaking due to defective seals or packing	Replace	1-S67
Fuel Mixed into Lubricant Oil	Injection pump's plunger worn	Repair or replace	G-28
	Deficient nozzle injection	Repair or replace nozzle	G-24
	Injection pump broken	Replace	G-28

Symptom	Probable Cause	Solution	Reference Page
Water Mixed into Lubricant Oil	Head gasket defective	Replace	1-S32
	Cylinder block or cylinder head flawed	Replace	1-S51
Low Oil Pressure	Engine oil insufficient	Replenish	I-4, G-7
	Oil strainer clogged	Clean	1-S34
	Relief valve stuck with dirt	Clean	–
	Relief valve spring weaken or broken	Replace	–
	Excessive oil clearance of crankshaft bearing	Replace	1-S63
	Excessive oil clearance of crankpin bearing	Replace	1-S62
	Excessive oil clearance of rocker arm	Replace	1-S55
	Oil passage clogged	Clean	–
	Different type of oil	Use specified type of oil	I-4, G-6
	Oil pump defective	Replace	1-S40
High Oil Pressure	Different type of oil	Use specified type of oil	I-4, G-6
	Relief valve defective	Replace	–
Engine Overheated	Engine oil insufficient	Replenish	I-4, G-7
	Fan belt broken or elongated	Replace or adjust	G-14
	Coolant insufficient	Replenish	G-8, G-19
	Radiator net and radiator fin clogged with dust	Clean	–
	Inside of radiator corroded	Clean or replace	–
	Coolant flow route corroded	Clean or replace	–
	Radiator cap defective	Replace	1-S18
	Overload running	Reduce the load	–
	Head gasket defective	Replace	1-S32
	Incorrect injection timing	Adjust	I-4, G-26
	Unsuitable fuel used	Use specified fuel	I-4, G-6
Battery Quickly Discharged	Battery electrolyte insufficient	Replenish distilled water and charge	G-15
	Fan belt slips	Adjust belt tension or replace	G-19
	Wiring disconnected	Connect	–
	Rectifier defective	Replace	1-S73
	Alternator defective	Replace	1-S72
	Battery defective	Replace	G-21

9Y1210785ENS0001US0

2. SERVICING SPECIFICATIONS

ENGINE BODY

Item		Factory Specification	Allowable Limit
Valve Clearance (Cold)		0.145 to 0.185 mm 0.00571 to 0.00728 in.	–
Compression Pressure	Z482-E4B D722-E4B D782-E4B	2.85 to 3.23 MPa 29.0 to 33.0 kgf/cm ² 413 to 469 psi	2.26 MPa 23.0 kgf/cm ² 327 psi
	Z602-E4B D902-E4B	3.53 to 4.02 MPa 36.0 to 41.0 kgf/cm ² 512 to 583 psi	2.55 MPa 26.0 kgf/cm ² 370 psi
• Difference among Cylinders		–	10 % or less
Top Clearance		0.50 to 0.70 mm 0.020 to 0.027 in.	–
Cylinder Head Surface	Flatness	–	0.05 mm 0.002 in.
Valve Recessing (Intake and Exhaust)		–0.10 to 0.10 mm –0.0039 to 0.0039 in.	0.30 mm 0.012 in.
Valve Stem to Valve Guide (Intake and Exhaust)	Clearance	0.030 to 0.057 mm 0.0012 to 0.0022 in.	0.10 mm 0.0039 in.
• Valve Stem	O.D.	5.968 to 5.980 mm 0.2350 to 0.2354 in.	–
• Valve Guide	I.D.	6.010 to 6.025 mm 0.2367 to 0.2372 in.	–
Valve Face (Intake and Exhaust)	Angle	0.79 rad 45 °	–
Valve Seat (Intake and Exhaust)	Angle	0.79 rad 45 °	–
	Width	2.12 mm 0.0835 in.	–
Intake Valve Timing [Z482/D722/D782-E4B]	Open	0.445 rad (25.5 °) before T.D.C.	–
	Close	0.881 rad (50.5 °) after B.D.C.	–
Exhaust Valve Timing [Z482/D722/D782-E4B]	Open	0.969 rad (55.5 °) before B.D.C.	–
	Close	0.201 rad (11.5 °) after T.D.C.	–
Intake Valve Timing [Z602/D902-E4B]	Open	0.35 rad (20 °) before T.D.C.	–
	Close	0.79 rad (45 °) after B.D.C.	–

Item		Factory Specification	Allowable Limit
Exhaust Valve Timing [Z602/D902-E4B]	Open	0.87 rad (50 °) before B.D.C.	–
	Close	0.26 rad (15 °) after T.D.C.	–
Valve Spring (Intake and Exhaust)	Tilt	–	1.2 mm 0.047 in.
	Free Length	31.3 to 31.8 mm 1.24 to 1.25 in.	28.4 mm 1.12 in.
	Setting Load / Setting Length	65 N / 27.0 mm 6.6 kgf / 27.0 mm 15 lbf / 1.06 in.	55 N / 27.0 mm 5.6 kgf / 27.0 mm 12 lbf / 1.06 in.
Rocker Arm Shaft to Rocker Arm • Rocker Arm Shaft • Rocker Arm	Oil Clearance	0.016 to 0.045 mm 0.00063 to 0.0017 in.	0.15 mm 0.0059 in.
	O.D.	10.473 to 10.484 mm 0.41233 to 0.41275 in.	–
	I.D.	10.500 to 10.518 mm 0.41339 to 0.41409 in.	–
Push Rod	Alignment	–	0.25 mm 0.0098 in.
Tappet to Tappet Bore • Tappet • Tappet Bore	Oil Clearance	0.016 to 0.052 mm 0.00063 to 0.0020 in.	0.10 mm 0.0039 in.
	O.D.	17.966 to 17.984 mm 0.70733 to 0.70803 in.	–
	I.D.	18.000 to 18.018 mm 0.70867 to 0.70937 in.	–
Timing Gear • Crank Gear to Idle Gear • Idle Gear to Cam Gear • Idle Gear to Injection Pump Gear • Crank Gear to Oil Pump Drive Gear	Backlash	0.0430 to 0.124 mm 0.00170 to 0.00488 in.	0.15 mm 0.0059 in.
	Backlash	0.0470 to 0.123 mm 0.00185 to 0.00484 in.	0.15 mm 0.0059 in.
	Backlash	0.0460 to 0.124 mm 0.00182 to 0.00488 in.	0.15 mm 0.0059 in.
	Backlash	0.0410 to 0.123 mm 0.00162 to 0.00484 in.	0.15 mm 0.0059 in.
Idle Gear	Side Clearance	0.20 to 0.51 mm 0.0079 to 0.020 in.	0.80 mm 0.031 in.
Camshaft	Side Clearance	0.15 to 0.31 mm 0.0059 to 0.012 in.	0.50 mm 0.020 in.
	Alignment	–	0.01 mm 0.0004 in.

Item		Factory Specification	Allowable Limit
Cam Height [Z482/D722/D782-E4B]	Intake	26.88 mm 1.058 in.	26.83 mm 1.056 in.
	Exhaust	25.88 mm 1.019 in.	25.83 mm 1.017 in.
	Intake and Exhaust	26.88 mm 1.058 in.	26.83 mm 1.056 in.
Camshaft Journal to Cylinder Block Bore	Oil Clearance	0.050 to 0.091 mm 0.0020 to 0.0035 in.	0.15 mm 0.0059 in.
	• Camshaft Journal O.D.	32.934 to 32.950 mm 1.2967 to 1.2972 in.	–
	• Cylinder Block Bore I.D.	33.000 to 33.025 mm 1.2993 to 1.3001 in.	–
Idle Gear Shaft to Idle Gear Bushing	Oil Clearance	0.020 to 0.084 mm 0.00079 to 0.0033 in.	0.10 mm 0.0039 in.
	• Idle Gear Shaft O.D.	19.967 to 19.980 mm 0.78611 to 0.78661 in.	–
	• Idle Gear Bushing I.D.	20.000 to 20.051 mm 0.78740 to 0.78940 in.	–
Piston Pin Bore	I.D.	20.000 to 20.013 mm 0.78741 to 0.78791 in.	20.05 mm 0.7894 in.
Piston Pin to Small End Bushing	Oil Clearance	0.014 to 0.038 mm 0.00056 to 0.0014 in.	0.10 mm 0.0039 in.
	• Piston Pin O.D.	20.002 to 20.011 mm 0.78748 to 0.78783 in.	–
	• Small End Bushing I.D.	20.025 to 20.040 mm 0.78839 to 0.78897 in.	–
Piston Pin to Small End Bushing (Spare Parts)	Oil Clearance	0.015 to 0.075 mm 0.00059 to 0.0029 in.	0.15 mm 0.0059 in.
	• Small End Bushing I.D.	20.026 to 20.077 mm 0.78843 to 0.79043 in.	–
Piston Ring Gap [Z482/D722/D782-E4B]	Top Ring	0.12 to 0.27 mm 0.0047 to 0.010 in.	1.15 mm 0.0453 in.
	Second Ring	0.30 to 0.45 mm 0.012 to 0.017 in.	1.20 mm 0.0472 in.
	Oil Ring	0.15 to 0.35 mm 0.0059 to 0.013 in.	1.20 mm 0.0472 in.
Piston Ring Gap [Z602/D902-E4B]	Top Ring	0.15 to 0.30 mm 0.0059 to 0.011 in.	1.25 mm 0.0472 in.
	Second Ring	0.35 to 0.50 mm 0.014 to 0.019 in.	1.25 mm 0.0492 in.
	Oil Ring	0.15 to 0.35 mm 0.0059 to 0.013 in.	1.20 mm 0.0472 in.

Item		Factory Specification	Allowable Limit
Piston Ring to Piston Ring Groove • Second Ring	Clearance	0.0900 to 0.120 mm 0.00355 to 0.00472 in.	0.15 mm 0.0059 in.
	• Oil Ring	Clearance	0.040 to 0.080 mm 0.0016 to 0.0031 in.
Connecting Rod	Alignment	–	0.05 mm 0.002 in.
Crankshaft	Side Clearance	0.15 to 0.35 mm 0.0059 to 0.012 in.	0.50 mm 0.020 in.
	Alignment	–	0.02 mm 0.0008 in.
Crank Pin to Crank Pin Bearing • Crank Pin • Crankpin Bearing	Oil Clearance	0.020 to 0.051 mm 0.00079 to 0.0020 in.	0.15 mm 0.0059 in.
	O.D.	33.959 to 33.975 mm 1.3370 to 1.3375 in.	–
	O.D.	33.995 to 34.010 mm 1.3384 to 1.3389 in.	–
Crankshaft Journal to Crankshaft Bearing 1 [Z482/D722/D782-E4B] • Crankshaft Journal • Crankshaft Bearing 1	Oil Clearance	0.0340 to 0.106 mm 0.00134 to 0.00417 in.	0.20 mm 0.0079 in.
	O.D.	39.934 to 39.950 mm 1.5722 to 1.5728 in.	–
	I.D.	39.984 to 40.040 mm 1.5742 to 1.5763 in.	–
Crankshaft Journal to Crankshaft Bearing 1 [Z602/D902-E4B] • Crankshaft Journal • Crankshaft Bearing 1	Oil Clearance	0.0340 to 0.106 mm 0.00134 to 0.00417 in.	0.20 mm 0.0079 in.
	O.D.	43.934 to 43.950 mm 1.7297 to 1.7303 in.	–
	I.D.	43.984 to 44.040 mm 1.7317 to 1.7338 in.	–
Crankshaft Journal to Crankshaft Bearing 2 (Flywheel Side) • Crankshaft Journal • Crankshaft Bearing 2	Oil Clearance	0.028 to 0.059 mm 0.0011 to 0.0023 in.	0.20 mm 0.0079 in.
	O.D.	43.934 to 43.950 mm 1.7297 to 1.7303 in.	–
	I.D.	43.978 to 43.993 mm 1.7315 to 1.7320 in.	–
Crankshaft Journal to Crankshaft Bearing 3 (Intermediate) [Z482/D722/D782-E4B] • Crankshaft Journal • Crankshaft Bearing 3	Oil Clearance	0.028 to 0.059 mm 0.0011 to 0.0023 in.	0.20 mm 0.0079 in.
	O.D.	39.934 to 39.950 mm 1.5722 to 1.5728 in.	–
	I.D.	39.978 to 39.993 mm 1.5740 to 1.5745 in.	–

Item		Factory Specification	Allowable Limit
Crankshaft Journal to Crankshaft Bearing 3 (Intermediate) [Z602/D902-E4B] • Crankshaft Journal • Crankshaft Bearing 3	Oil Clearance	0.028 to 0.059 mm 0.0011 to 0.0023 in.	0.20 mm 0.0079 in.
	O.D.	43.934 to 43.950 mm 1.7297 to 1.7303 in.	–
	I.D.	43.978 to 43.993 mm 1.7315 to 1.7320 in.	–
Cylinder Liner [Z482/D722/D782-E4B]	I.D.	67.000 to 67.019 mm 2.6378 to 2.6385 in.	67.150 mm 2.6437 in.
Cylinder Liner [Z602/D902-E4B]	I.D.	72.000 to 72.019 mm 2.8347 to 2.8353 in.	72.150 mm 2.8406 in.
Cylinder Liner [Oversize : 0.25 mm (0.0098 in.)] [Z482/D722/D782-E4B]	I.D.	67.250 to 67.269 mm 2.6477 to 2.6483 in.	67.400 mm 2.6535 in.
Cylinder Liner [Oversize : 0.25 mm (0.0098 in.)] [Z602/D902-E4B]	I.D.	72.250 to 72.269 mm 2.8445 to 2.8452 in.	72.400 mm 2.8504 in.

LUBRICATING SYSTEM

Item		Factory Specification	Allowable Limit
Engine Oil Pressure	At Idle Speed	More than 49 kPa 0.50 kgf/cm ² 7.1 psi	—
	At Rated Speed	197 to 441 kPa 2.00 to 4.50 kgf/cm ² 28.5 to 64.0 psi	147 kPa 1.50 kgf/cm ² 21.3 psi
Inner Rotor to Outer Rotor	Clearance	0.030 to 0.14 mm 0.0012 to 0.0055 in.	—
Outer Rotor to Pump Body	Clearance	0.070 to 0.15 mm 0.0028 to 0.0059 in.	—
Inner Rotor to Cover	Clearance	0.0750 to 0.135 mm 0.00296 to 0.00531 in.	—

COOLING SYSTEM

Item		Factory Specification	Allowable Limit
Fan Belt	Tension	7.0 to 9.0 mm / 98 N 0.28 to 0.35 in. / 98 N (10 kgf, 22 lbf)	—
Thermostat	Valve Opening Temperature (At Beginning)	69.5 to 72.5 °C 157.1 to 162.5 °F	—
	Valve Opening Temperature (Opened Completely)	85 °C 185 °F	—
Radiator Cap	Pressure Falling Time	10 seconds or more 88 → 59 kPa 0.90 → 0.60 kgf/cm ² 13 → 8.5 psi	—
Radiator	Water Leakage Test Pressure	No leak at specified pressure	—

FUEL SYSTEM

Item		Factory Specification	Allowable Limit
Injection Pump [Z482/D602-E4B]	Injection Timing (3600 min ⁻¹ (rpm))	0.3186 to 0.3447 rad (18.25 to 19.75 °) before T.D.C.	–
Injection Pump [D722-E4B]	Injection Timing (3200 min ⁻¹ (rpm))	0.3360 to 0.3621 rad (19.25 to 20.75 °) before T.D.C.	–
Injection Pump [D782-E4B]	Injection Timing (3200 min ⁻¹ (rpm))	0.2837 to 0.3097 rad (16.25 to 17.75 °) before T.D.C.	–
Injection Pump [D902-E4B]	Injection Timing (3600 min ⁻¹ (rpm))	0.3186 to 0.3447 rad (18.25 to 19.75 °) before T.D.C.	–
Pump Element	Fuel Tightness	–	13.73 MPa 140.0 kgf/cm ² 1991 psi
Delivery Valve	Fuel Tightness	10 seconds 13.73 → 12.75 MPa 140.0 → 130.0 kgf/cm ² 1991 → 1849 psi	5 seconds 13.73 → 12.75 MPa 140.0 → 130.0 kgf/cm ² 1991 → 1849 psi
Injection Nozzle	Injection Pressure	13.73 to 14.70 MPa 140.0 to 150.0 kgf/cm ² 1992 to 2133 psi	–
Injection Nozzle Valve Seat	Valve Seat Tightness	When the pressure is 12.75 MPa (130.0 kgf/cm ² , 1849 psi), the valve seat must be fuel tightness	–

ELECTRICAL SYSTEM

Item		Factory Specification	Allowable Limit
Glow Plug	Resistance	Approx. 1.1 Ω	–
Starter (Electromagnetic Drive Type) • Commutator	O.D.	28.0 mm 1.10 in.	27.0 mm 1.06 in.
	• Difference	Less than 0.05 mm 0.002 in.	0.40 mm 0.016 in.
	• Mica	Undercut 0.50 to 0.80 mm 0.020 to 0.031 in.	0.20 mm 0.0079 in.
	• Brush	Length 16.0 mm 0.630 in.	10.5 mm 0.413 in.
Starter (Planetary Gear Reduction Type) • Commutator	O.D.	30.0 mm 1.18 in.	29.0 mm 1.14 in.
	• Difference	Less than 0.02 mm 0.0008 in.	0.05 mm 0.002 in.
	• Mica	Undercut 0.50 to 0.80 mm 0.020 to 0.031 in.	0.20 mm 0.0079 in.
	• Brush	Length 14.0 mm 0.551 in.	9.0 mm 0.35 in.
Dynamo • No-load	Output Voltage	AC20V or more at 5200 min ⁻¹ (rpm)	–
	• Regulating	Output Voltage 14 to 15 V at 5200 min ⁻¹ (rpm)	–
Alternator • Stator	Resistance	Less than 1.0 Ω	–
	• Rotor	Resistance 2.9 Ω	–
	• Slip Ring	O.D. 14.4 mm 0.567 in.	14.0 mm 0.551 in.
	• Brush	Length 10.0 mm 0.394 in.	8.4 mm 0.33 in.

9Y1210785ENS0002US0



3. TIGHTENING TORQUES

Screws, bolts and nuts must be tightened to the specified torque using a torque wrench, several screws, bolts and nuts such as those used on the cylinder head must be tightened in proper sequence and the proper torque.

9Y1210785ENS0003US0

[1] TIGHTENING TORQUES FOR GENERAL USE SCREWS, BOLTS AND NUTS

When the tightening torques are not specified, tighten the screws, bolts and nuts according to the table below.

Indication on top of bolt	 No-grade or 4T			 7T			
	Unit	N·m	kgf·m	lbf·ft	N·m	kgf·m	lbf·ft
M6		7.9 to 9.3	0.80 to 0.95	5.8 to 6.8	9.81 to 11.2	1.00 to 1.15	7.24 to 8.31
M8		18 to 20	1.8 to 2.1	13 to 15	24 to 27	2.4 to 2.8	18 to 20
M10		40 to 45	4.0 to 4.6	29 to 33	48 to 55	4.9 to 5.7	36 to 41
M12		63 to 72	6.4 to 7.4	47 to 53	78 to 90	7.9 to 9.2	58 to 66

Screw and bolt material grades are shown by numbers punched on the screw and bolt heads. Prior to tightening, be sure to check out the numbers as shown below.

Punched number	Screw and bolt material grade
None or 4	Standard screw and bolt SS41, S20C
7	Special screw and bolt S43C, S48C (Refined)

9Y1210785ENS0004US0

[2] TIGHTENING TORQUES FOR SPECIAL USE SCREWS, BOLTS AND NUTS

■ NOTE

- For "*" marked screws, bolts and nuts on the table, apply engine oil to their threads and seats before tightening.
- The letter "M" in Size × Pitch means that the screw, bolt or nut dimension stands for metric. The size is the nominal outside diameter in mm of the threads. The pitch is the nominal distance in mm between two threads.

Item	Dimension × Pitch	N·m	kgf·m	lbf·ft
*Cylinder head cover screw	M6 × 1	9.81 to 11.2	1.00 to 1.15	7.24 to 8.31
Injection pipe retaining nut	M12 × 1.5	25 to 34	2.5 to 3.5	18 to 25
Overflow pipe retaining nut	M12 × 1.5	20 to 24	2.0 to 2.5	15 to 18
Nozzle holder assembly	M20 × 1.5	49 to 68	5.0 to 7.0	37 to 50
Glow plug	M8 × 1	7.9 to 14	0.80 to 1.5	5.8 to 10
*Rocker arm bracket nut	M6 × 1	9.81 to 11.2	1.00 to 1.15	7.24 to 8.31
*Cylinder head screw	M8 × 1.25	38 to 42	3.8 to 4.3	28 to 31
*Fan drive pulley screw	M12 × 1.5	118 to 127	12.0 to 13.0	86.8 to 94.0
*Idle gear shaft mounting screw	M6 × 1	9.81 to 11.2	1.00 to 1.15	7.24 to 8.31
Oil pump mounting screw	M8 × 1.25	17.7 to 21.5	1.80 to 2.20	13.1 to 15.9
*Connecting rod screw	M7 × 0.75	27 to 30	2.7 to 3.1	20 to 22
*Flywheel screw	M10 × 1.25	54 to 58	5.5 to 6.0	40 to 43
Bearing case cover mounting screw	M6 × 1	9.81 to 11.2	1.00 to 1.15	7.24 to 8.31
*Main bearing case screw 2	M7 × 1	27 to 30	2.7 to 3.1	20 to 22
*Main bearing case screw 1	M6 × 1	13 to 15	1.3 to 1.6	9.4 to 11
Oil pressure switch	PT 1/8	15 to 19	1.5 to 2.0	11 to 14
Nozzle holder	–	35 to 39	3.5 to 4.0	26 to 28
Starter's terminal B mounting nut (Electromagnetic drive type)	M8	7.9 to 9.8	0.80 to 1.0	5.8 to 7.2
Starter's terminal B mounting nut (Planetary gear reduction type)	M8	5.9 to 11	0.60 to 1.2	4.4 to 8.6
Dynamo's pulley nut	M10 × 1.25	40 to 44	4.0 to 4.5	29 to 32
Alternator's pulley nut	–	58.4 to 78.9	5.95 to 8.05	43.1 to 58.2
Drain plug with copper gasket	M12 × 1.25	33 to 37	3.3 to 3.8	24 to 27
Drain plug with copper gasket	M22 × 1.5	64 to 73	6.5 to 7.5	47 to 54
Drain plug with rubber coated gasket	M22 × 1.5	45 to 53	4.5 to 5.5	33 to 39

9Y1210785ENS0005US0

4. CHECKING, DISASSEMBLING AND SERVICING

[1] CHECKING AND ADJUSTING

(1) Engine Body



Compression Pressure

1. Run the engine until it is warmed up.
2. Stop the engine.
3. **[a] Nozzle Hole Adaptor Setting :**
Remove the air cleaner, the muffler and all injection nozzles.
[b] Glow Plug Hole Adaptor Setting :
Remove the air cleaner, the muffler, the breather tube, the head cover and all glow plugs.
4. **[a] Nozzle Hole Adaptor Setting :**
Set a compression tester (Code No. 07909-30208) with the adaptor (Adaptor H, code No. 07909-31231) to the nozzle hole.
[b] Glow Plug Hole Adaptor Setting :
Set a compression tester (Code No. 07909-30208) with the adaptor (Adaptor L, code No. 07909-31301) to the glow plug hole.
5. After making sure that the stop lever is set at the stop position (non-injection), run the engine with the starter and measure the compression pressure.
6. Repeat steps 4 and 5 for each cylinder.
7. If the measurement is below the allowable limit, apply a small amount of oil to the cylinder wall through the glow plug hole (or nozzle hole) and measure the compression pressure again.
8. If the compression pressure is still less than the allowable limit, check the top clearance, valve clearance and cylinder head.
9. If the compression pressure increases after applying oil, check the cylinder wall and piston rings.

■ NOTE

- Check the compression pressure with the specified valve clearance.
- Always use a fully charged battery for performing this test.
- Variances in cylinder compression values should be under 10 %.

Compression pressure	Z482-E4B D722-E4B D782-E4B	Factory specification	2.85 to 3.23 MPa 29.0 to 33.0 kgf/cm ² 413 to 469 psi
		Allowable limit	2.26 MPa 23.0 kgf/cm ² 327 psi
	Z602-E4B D902-E4B	Factory specification	3.53 to 4.02 MPa 36.0 to 41.0 kgf/cm ² 512 to 583 psi
		Allowable limit	2.55 MPa 26.0 kgf/cm ² 370 psi

[a] Nozzle Hole Adaptor Setting

[b] Glow Plug Hole Adaptor Setting

9Y1210785ENS0006US0

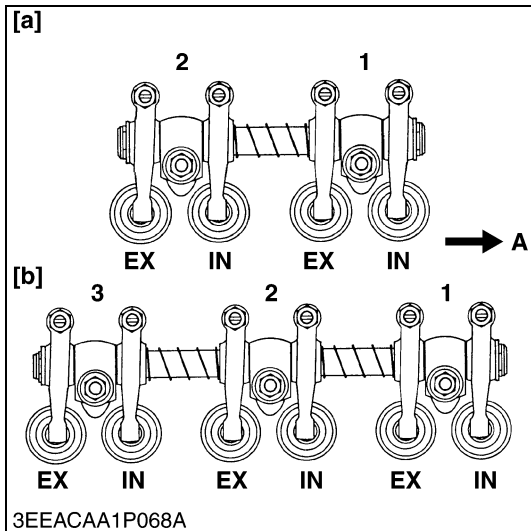
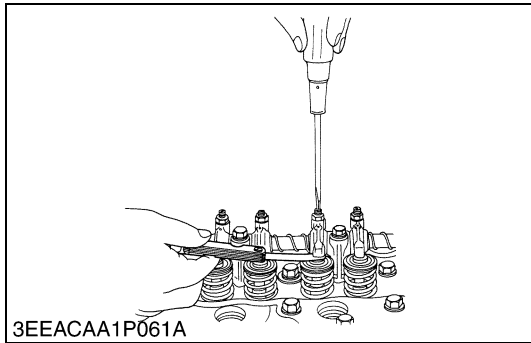
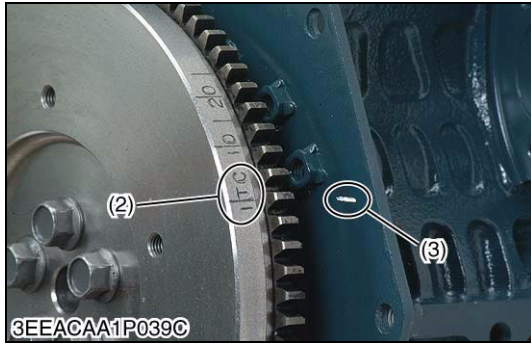
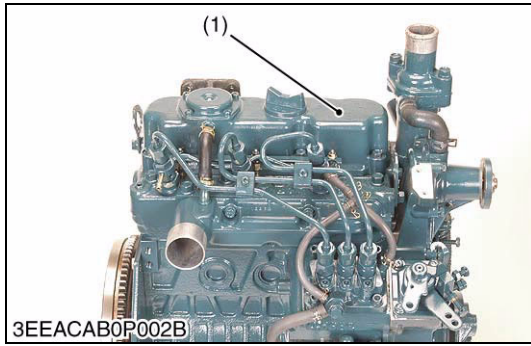

Checking Valve Clearance

■ **IMPORTANT**

- **Valve clearance must be checked and adjusted when engine is cold.**
1. Remove the cylinder head cover (1) and the glow plugs.
 2. Align the "1TC" mark (2) on the flywheel and alignment mark (3) on the rear end plate so that the No. 1 piston comes to the compression top dead center.
 3. Check the following valve clearance marked with "★" using a feeler gauge.
 4. If the clearance is not within the factory specifications, adjust with the adjusting screw.
 5. Then turn the flywheel 6.28 rad (360 °), and align the "1TC" mark (2) on the flywheel and alignment mark (3) on the rear end plate so that the No. 1 piston comes to the overlap position.
 6. Check the following valve clearance marked with "☆" using a feeler gauge.
 7. If the clearance is not within the factory specifications, adjust with the adjusting screw.

Adjustable cylinder location of piston	Number of cylinders Valve arrangement			
	Z482-E4B Z602-E4B		D722-E4B D782-E4B D902-E4B	
	Intake valve	Exhaust valve	Intake valve	Exhaust valve
No.1	★	★	★	★
No.2	☆	★	☆	★
No.3	—	—	★	☆

★ : When No. 1 piston is at the compression top dead center position.
 ☆ : When No. 1 piston is at the overlap position.

Intake and exhaust valve clearance (cold)	Factory specification	0.145 to 0.185 mm 0.00571 to 0.00728 in.
---	-----------------------	---

■ **NOTE**

- **The sequence of cylinder numbers is given as No. 1, No. 2 and No. 3 starting from the gear case side.**
- **After adjusting the valve clearance, secure the adjusting screw with the lock nut.**

- (1) Cylinder Head Cover
- (2) "1TC" Mark
- (3) Alignment Mark

- A: Gear Case Side
- [a] Z482-E4B, Z602-E4B
- [b] D722-E4B, D782-E4B, D902-E4B

9Y1210785GEG0030US0

(2) Lubricating System

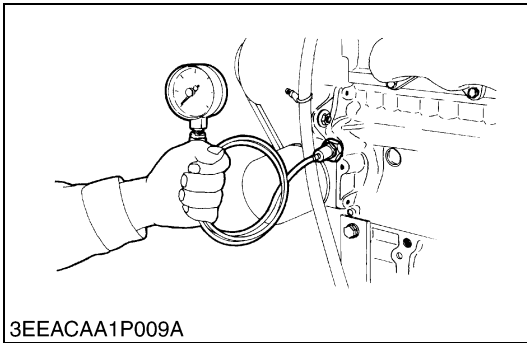

Engine Oil Pressure

1. Remove the engine oil pressure switch, and set an oil pressure tester. (Code No. : 07916-32032)
2. Start the engine. After warming up, measure the oil pressure of both idling and rated speeds.
3. If the oil pressure is less than the allowable limit, check the following.
 - Engine oil insufficient
 - Oil pump defective
 - Oil strainer clogged
 - Oil filter cartridge clogged
 - Oil gallery clogged
 - Excessive oil clearance
 - Foreign matter in the relief valve

Engine oil pressure	At idle speed	Factory specification	More than 49 kPa 0.50 kgf/cm ² 7.1 psi
	At rated speed	Factory specification	197 to 441 kPa 2.00 to 4.50 kgf/cm ² 28.5 to 64.0 psi
		Allowable limit	147 kPa 1.50 kgf/cm ² 21.3 psi

(When reassembling)

- After checking the engine oil pressure, tighten the engine oil pressure switch to the specified torque.

Tightening torque	Oil pressure switch	15 to 19 N·m 1.5 to 2.0 kgf·m 11 to 14 lbf·ft
-------------------	---------------------	---

9Y1210785ENS0007US0

(3) Cooling System

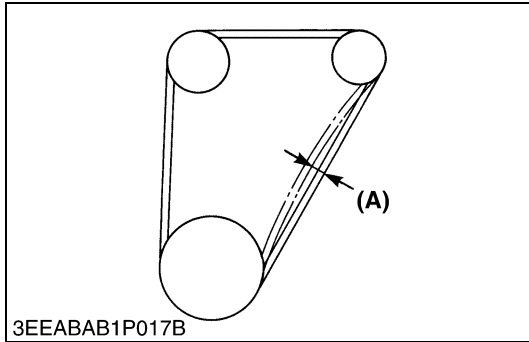

Fan Belt Tension

1. Measure the deflection **(A)**, depressing the belt halfway between the fan drive pulley and alternator pulley at specified force 98 N (10 kgf, 22 lbf).
2. If the measurement is not within the factory specifications, loosen the alternator mounting screws and relocate the alternator to adjust.

Deflection (A)	Factory specification	7.0 to 9.0 mm 0.28 to 0.35 in.
-----------------------	-----------------------	-----------------------------------

(A) Deflection

9Y1210785GEG0013US0

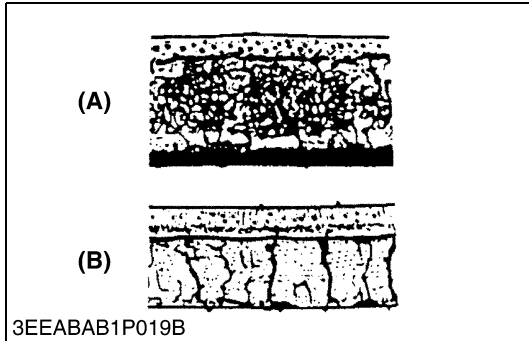

Fan Belt Damage and Wear

1. Check the fan belt for damage.
2. If the fan belt is damaged, replace it.
3. Check if the fan belt is worn and sunk in the pulley groove.
4. If the fan belt is nearly worn out and deeply sunk in the pulley groove, replace it.

(A) Good

(B) Bad

9Y1210785GEG0014US0

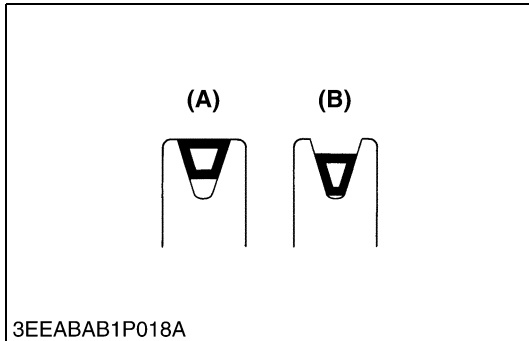

CAUTION

- When removing the radiator cap, wait at least ten minutes after the engine has stopped and cooled down. Otherwise, hot water may gush out, scalding nearby people.

9Y1210785ENS0008US0

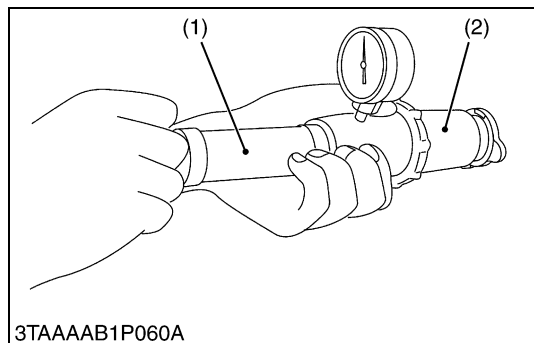

Radiator Cap Air Leakage

- Set a radiator tester (1) and an adaptor (2) on the radiator cap.
- Apply the specified pressure of 88 kPa (0.90 kgf/cm², 13 psi), and measure the time for the pressure to fall to 59 kPa (0.60 kgf/cm², 8.5 psi).
- If the measurement is less than the factory specification, replace the radiator cap.

Pressure falling time	Factory specification	More than 10 seconds for pressure fall 88 → 59 kPa (0.90 → 0.60 kgf/cm ² , 13 → 8.5 psi)
-----------------------	-----------------------	--

(1) Radiator Tester (2) Adaptor

9Y1210785ENS0009US0

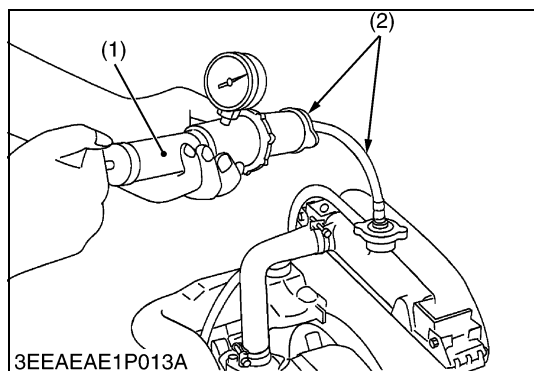

Radiator Water Leakage

- Pour a specified amount of water into the radiator.
- Set a radiator tester (1) and an adaptor (2) and raise the water pressure to the specified pressure.
- Check the radiator for water leaks.
- For water leak from the pinhole, replace the radiator or repair with the radiator cement. When water leak is excessive, replace the radiator.

Radiator water leakage test pressure	Factory specification	No leak at specified pressure
--------------------------------------	-----------------------	-------------------------------

NOTE

- The pressure of the leak test is different from each radiator specification. Thus, do the leak test, refer to the test pressure of each radiator specification.

(1) Radiator Tester (2) Adaptor

9Y1210785ENS0010US0

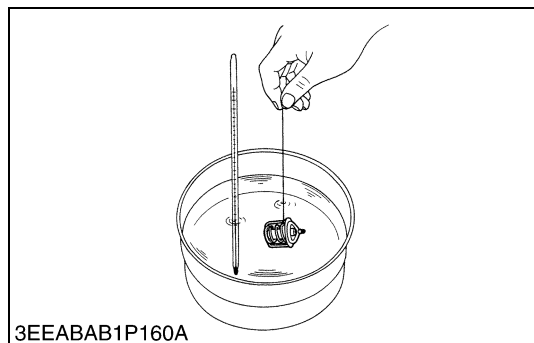

Thermostat Valve Opening Temperature

- Suspend the thermostat in the water by a string with its end inserted between the valve and seat.
- Heating the water gradually, read the temperature when the valve opens and leaves the string.
- Continue heating and read the temperature when the valve opens approx. 8.0 mm (0.31 in.).
- If the measurement is not within the factory specifications, replace the thermostat.

Thermostat's valve opening temperature	Factory specification	69.5 to 72.5 °C 157.1 to 162.5 °F
Temperature at which thermostat completely opens	Factory specification	85 °C 185 °F

9Y1210785ENS0011US0

(4) Fuel System

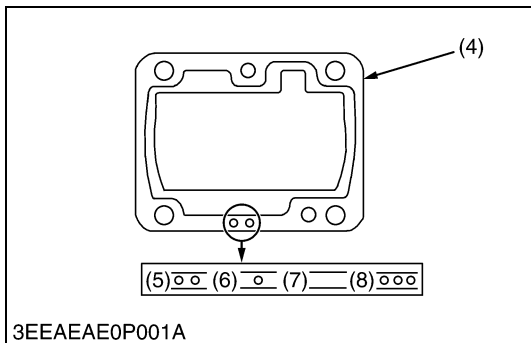
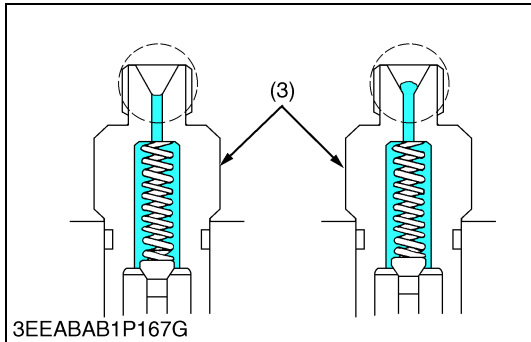
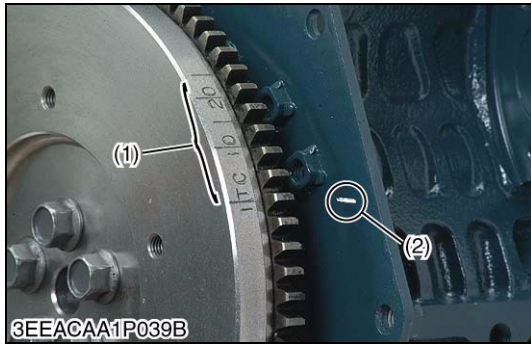

Injection Timing

1. Remove the injection pipes.
2. Remove the engine stop solenoid.
3. Turn the flywheel counterclockwise (viewed from flywheel side) until the fuel fills up to the hole of the delivery valve holder (3) for No. 1 cylinder.
4. After the fuel fills up to the hole of the delivery valve holder for No. 1 cylinder, turn back (clockwise) the flywheel around 1.6 rad (90 °).
5. Turn the flywheel counterclockwise to set at around 0.44 rad (25 °) before T.D.C..
6. Slowly turn the flywheel counterclockwise and stop turning when the fuel begins to come up, to get the present injection timing.
7. Check to see the degree on flywheel.
The flywheel has mark "1TC", "10" and "20" for the crank angle before the top dead center of No. 1 cylinder.
8. Check to see if the timing angle on the flywheel is aligned with the alignment mark (2).
9. If injection timing is out of adjustment, readjust the timing with shims.

Z482/D602-E4B (3600 min⁻¹ (rpm) spec.)

Injection timing	Factory specification	0.3186 to 0.3447 rad (18.25 to 19.75 °) before T.D.C.
------------------	-----------------------	---

D722-E4B (3200 min⁻¹ (rpm) spec.)

Injection timing	Factory specification	0.3360 to 0.3621 rad (19.25 to 20.75 °) before T.D.C.
------------------	-----------------------	---

D782-E4B (3200 min⁻¹ (rpm) spec.)

Injection timing	Factory specification	0.2837 to 0.3097 rad (16.25 to 17.75 °) before T.D.C.
------------------	-----------------------	---

D902-E4B (3600 min⁻¹ (rpm) spec.)

Injection timing	Factory specification	0.3186 to 0.3447 rad (18.25 to 19.75 °) before T.D.C.
------------------	-----------------------	---

- | | |
|--|---|
| <p>(1) Timing Line
 (2) Alignment Mark
 (3) Delivery Valve Holder
 (4) Shim (Soft Metal Gasket Shim)</p> | <p>(5) Two-holes : 0.20 mm (0.0079 in.)
 Two-holes : 0.175 mm (0.00689 in.)
 (6) One-hole : 0.25 mm (0.0098 in.)
 (7) Without hole : 0.30 mm (0.012 in.)
 (8) Three-holes : 0.35 mm (0.014 in.)</p> |
|--|---|

(To be continued)

(Continued)

■ **NOTE**

- The liquid gasket is not required for assembling.
- Shims are available in thickness of 0.20 mm (0.0079 in.), 0.25 mm (0.0098 in.), 0.30 mm (0.012 in.), 0.35 mm (0.014 in.) and 0.175 mm (0.00689 in.). Combine these shims for adjustments.
- Addition or reduction of shim (0.025 mm, 0.00098 in.) delays or advances the injection timing by approx. 0.0044 rad (0.25 °).
- In disassembling and replacing the injection pump, be sure to use the same number of new shims with the same thickness.
- The 0.175 mm (0.00689 in.) thick shim is coated only on the lower face. Therefore, do not use the 0.175 mm (0.00689 in.) thick shim as the top shim of the combination (injection pump side), because this can cause oil leakage.
- Refer to figure of the shim to check the thickness of the shims.
- The injection timing might be changed by the application.

9Y1210785GEG0036US0

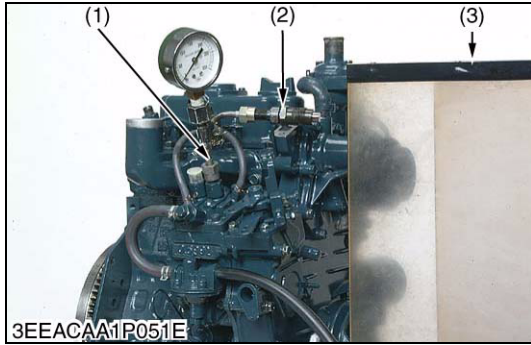

Fuel Tightness of Pump Element

1. Remove the engine stop solenoid.
2. Remove the injection pipes and glow plugs.
3. Install the injection pump pressure tester to the injection pump.
4. Install the injection nozzle (2) jetted with the proper injection pressure to the injection pump pressure tester (1). (Refer to the photo.)
5. Set the speed control lever to the maximum speed position.
6. Run the starter to increase the pressure.
7. If the pressure can not reach the allowable limit, replace the pump with new one or repair with a KUBOTA-authorized pump service shop.

Fuel tightness of pump element	Allowable limit	13.73 MPa 140.0 kgf/cm ² 1991 psi
--------------------------------	-----------------	--

NOTE

- **Never try to disassemble the injection pump assembly. For repairs, you are strongly requested to contact a KUBOTA-authorized pump service shop.**

- (1) Injection Pump Pressure Tester (3) Protection Cover for Jetted Fuel
(2) Injection Nozzle

9Y1210785ENS0012US0

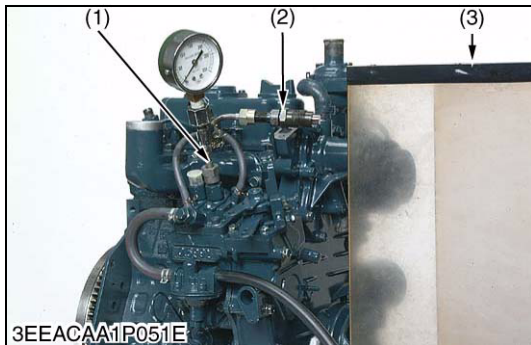

Fuel Tightness of Delivery Valve

1. Remove the engine stop solenoid.
2. Remove the injection pipes and glow plugs.
3. Set a pressure tester to the fuel injection pump.
4. Install the injection nozzle (2) jetted with the proper injection pressure to the injection pump pressure tester (1).
5. Run the starter to increase the pressure.
6. Stop the starter when the fuel jets from the injection nozzle. After that, turn the flywheel by hands and raise the pressure to approx. 13.73 MPa (140.0 kgf/cm², 1991 psi).
7. Now turn the flywheel back about half a turn (to keep the plunger free). Maintain the flywheel at this position and clock the time taken for the pressure to drop from 13.73 to 12.75 MPa (from 140.0 to 130.0 kgf/cm², from 1991 to 1849 psi).
8. Measure the time needed to decrease the pressure from 13.73 to 12.75 MPa (from 140.0 to 130.0 kgf/cm², from 1991 to 1849 psi).
9. If the measurement is less than allowable limit, replace the pump with new one or repair with a KUBOTA-authorized pump service shop.

Fuel tightness of delivery valve	Factory specification	10 seconds 13.73 → 12.75 MPa 140.0 → 130.0 kgf/cm ² 1991 → 1849 psi
	Allowable limit	5 seconds 13.73 → 12.75 MPa 140.0 → 130.0 kgf/cm ² 1991 → 1849 psi

NOTE

- **Never try to disassemble the injection pump assembly. For repairs, you are strongly requested to contact a KUBOTA-authorized pump service shop.**

- (1) Injection Pump Pressure Tester (3) Protection Cover for Jetted Fuel
(2) Injection Nozzle

9Y1210785ENS0013US0

CAUTION

- Check the injection pressure and condition after confirming that there is nobody standing in the direction the fume goes.
- If the fume from the nozzle directly contacts the human body, cells may be destroyed and blood poisoning may be caused.

9Y1210785GEG0031US0

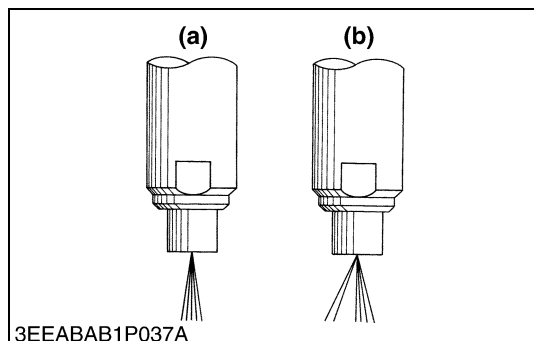

Nozzle Spraying Condition

1. Set the injection nozzle to a nozzle tester, and check the nozzle spraying condition.
2. If the spraying condition is defective, replace the nozzle piece.

(a) Good

(b) Bad

9Y1210785GEG0032US0

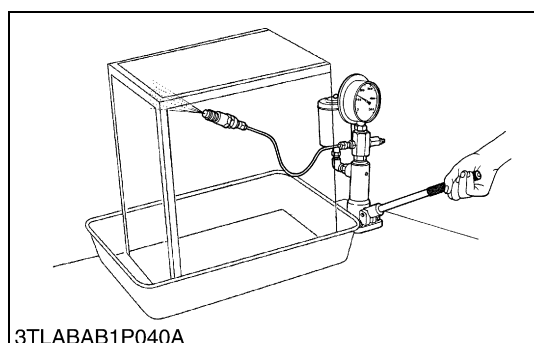

Fuel Injection Pressure

1. Set the injection nozzle to a nozzle tester.
2. Slowly move the tester handle to measure the pressure at which fuel begins jetting out from the nozzle.
3. If the measurement is not within the factory specifications, replace the adjusting washer (1) in the nozzle holder to adjust it.

(Reference)

- Pressure variation with 0.025 mm (0.00098 in.) difference of adjusting washer thickness.
Approx. 590 kPa (6.0 kgf/cm², 85 psi)

Fuel injection pressure	Factory specification	13.73 to 14.70 MPa 140.0 to 150.0 kgf/cm ² 1992 to 2133 psi
-------------------------	-----------------------	--

(1) Adjusting Washer

9Y1210785GEG0033US0

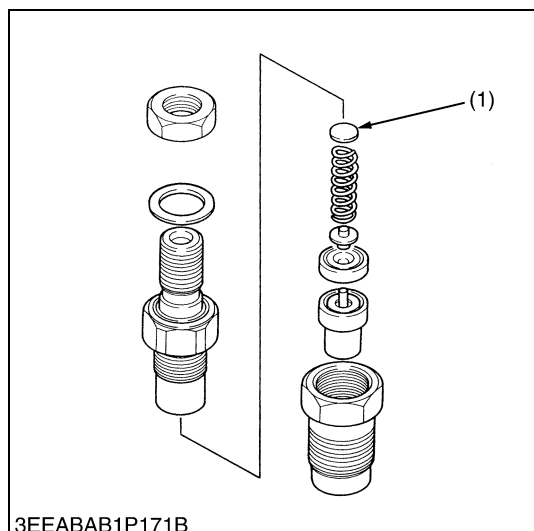

Nozzle Valve Seat Tightness

1. Set the injection nozzle to a nozzle tester.
2. Raise the fuel pressure, and keep at 12.75 MPa (130.0 kgf/cm², 1849 psi) for 10 seconds.
3. If any fuel leak is found, replace the nozzle piece.

Valve seat tightness	Factory specification	No fuel leak at 12.75 MPa 130.0 kgf/cm ² 1849 psi
----------------------	-----------------------	---

9Y1210785GEG0034US0

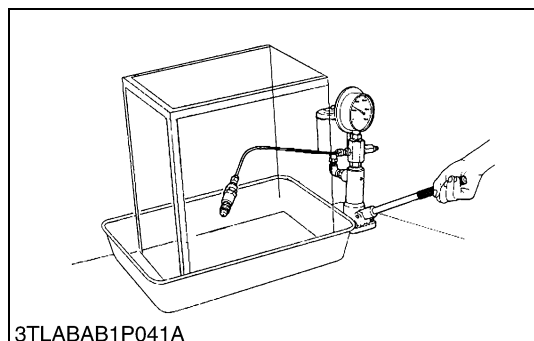

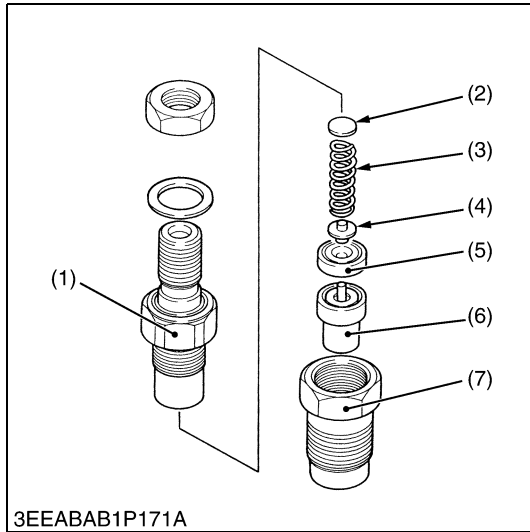

Nozzle Holder

1. Secure the nozzle retaining nut (7) with a vise.
2. Remove the nozzle holder (1), and take out parts inside.

(When reassembling)

- Assemble the nozzle in clean fuel oil.
- Install the push rod (4), noting its direction.
- After assembling the nozzle, be sure to adjust the fuel injection pressure.

Tightening torque	Nozzle holder	35 to 39 N·m 3.5 to 4.0 kgf·m 26 to 28 lbf·ft
	Overflow pipe retaining nut	20 to 24 N·m 2.0 to 2.5 kgf·m 15 to 18 lbf·ft
	Nozzle holder assembly	49 to 68 N·m 5.0 to 7.0 kgf·m 37 to 50 lbf·ft

- | | |
|----------------------|--------------------------|
| (1) Nozzle Holder | (5) Distance Piece |
| (2) Adjusting Washer | (6) Nozzle Piece |
| (3) Nozzle Spring | (7) Nozzle Retaining Nut |
| (4) Push Rod | |

9Y1210785GEG0035US0

(5) Electrical System

⚠ CAUTION

- To avoid accidental short circuit, be sure to attach the positive cable to the positive terminal before the negative cable is attached to the negative terminal.
- Never remove the battery cap while the engine is running.
- Keep electrolyte away from eyes, hands and clothes. If you are splattered with it, wash it away completely with water immediately.
- Keep open sparks and flames away from the battery at all times. Hydrogen gas mixed with oxygen becomes very explosive.

■ IMPORTANT

- If the machine is to be operated for a short time without battery (using a slave battery for starting), use additional current (lights) while engine is running and insulate terminal of battery. If this advice is disregarded, damage to alternator and regulator may result.

9Y1210785ENS0014US0

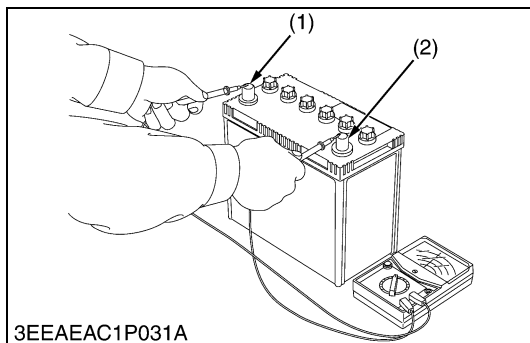

Battery Voltage

1. Stop the engine.
2. Measure the voltage with a circuit tester between the battery terminals.
3. If the battery voltage is less than the factory specification, check the battery specific gravity and recharge the battery.

Battery voltage	Factory specification	More than 12 V
-----------------	-----------------------	----------------

- | | |
|-----------------------|-----------------------|
| (1) Positive Terminal | (2) Negative Terminal |
|-----------------------|-----------------------|

9Y1210785ENS0015US0

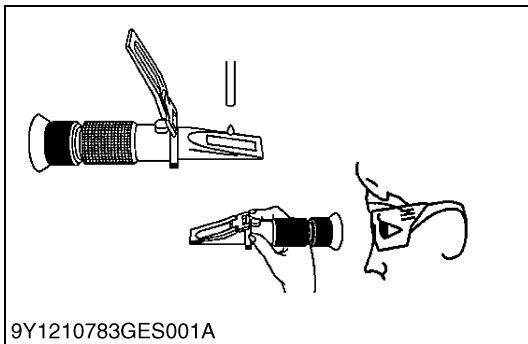

Battery Specific Gravity

⚠ CAUTION

- If battery acid (dilute sulfuric acid) gets on you it could cause blindness or burns, or could cause corrosion of machinery and tools so please be careful when handling.
- Wear safety glasses and rubber gloves when performing battery maintenance and inspection (measuring specific gravity, replenishing water, or charging).
- If the gas that is generated is ignited by an ignition source, it may explode so be very careful with sparks and fire.
- Keep your body and face as far away from the battery as you can when performing maintenance and inspection.
- Do not allow people who do not know how to handle a battery or who do not sufficiently understand the danger perform inspection or maintenance.

(Measurement items)

■ Zero adjustment

1. Open the cover and drip water on the prism surface using the included rod.
2. Close the cover.
3. Aim in a direction that is bright, look into the lens, and adjust the focus until the gradations can be seen clearly.
4. If the boundary line is not on the gradation baseline (0 position), turn the adjustment screw until it matches.
5. When zero adjustment is complete, wipe the prism and cover surface with a soft cloth or tissue paper.

■ Measurement of test fluid

1. Open the cover and drip test fluid on the prism surface using the included rod.
2. Close the cover.
3. Aim in a direction that is bright, look into the lens and read the gradation of the blue boundary line.
4. When the measurement is complete, wipe the prism and cover surface with a soft cloth or tissue paper.

(Reference)

Electrolyte specific gravity and amount of discharge.
Use the following table as a reference.

(A) Electrolyte Specific Gravity	(C) Good
(B) Discharge	(D) Charging is necessary.

■ NOTE

Temperature conversion of electrolyte specific gravity

- Battery electrolyte specific gravity changes based on temperature.
- Insert the value identified on a specific gravity meter into the following conversion equation for temperature correction to learn an accurate specific gravity value. (Standard temperature assumed to be 20 °C (68 °F))

$$D_{20} = D_t + 0.0007 (t - 20)$$

$$D_{20} = \text{specific gravity value converted to standard temperature of } 20 \text{ }^\circ\text{C (68 }^\circ\text{F)}$$

$$D_t = \text{measured specific gravity value at the electrolyte temperature } t \text{ }^\circ\text{C}$$

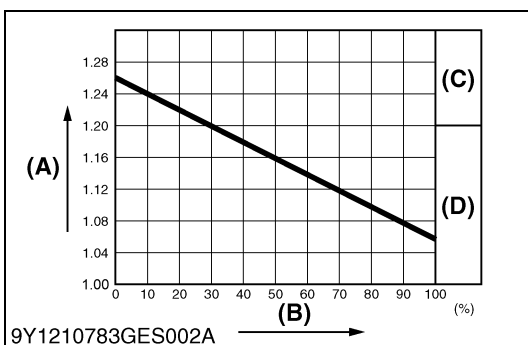

9Y1210785GEG0028US0

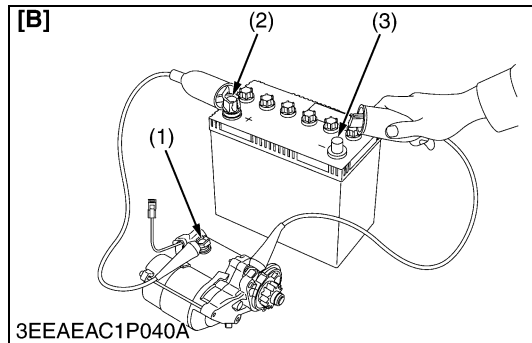
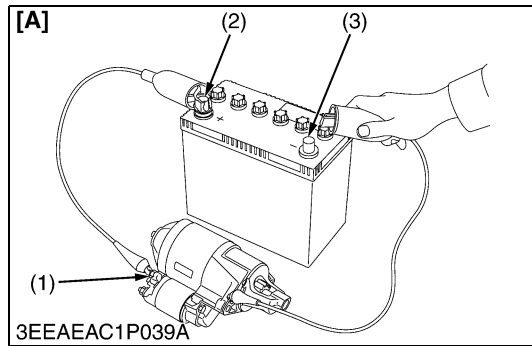

Motor Test



CAUTION

- **Secure the starter to prevent it from jumping up and down while testing the motor.**
1. Disconnect the battery negative cable from the battery.
 2. Disconnect the battery positive cable from the battery.
 3. Disconnect the leads from the starter **B** terminal.
 4. Remove the starter from the engine.
 5. Connect a jumper lead from the starter **C** terminal (1) to the battery positive terminal (2).
 6. Connect a jumper lead momentarily between the starter's body and the battery negative terminal (3).
 7. If the motor does not run, starter is failure. Repair or replace the starter.

NOTE

- **B terminal** : It is the terminal which connects the cable from the battery to the starter.
- **C terminal** : It is the terminal which connects the cable from the motor to the magnet switch.

- (1) C Terminal
 (2) Positive Terminal
 (3) Negative Terminal

[A] Electromagnetic Drive Type

[B] Planetary Gear Reduction Type

9Y1210785ENS0016US0

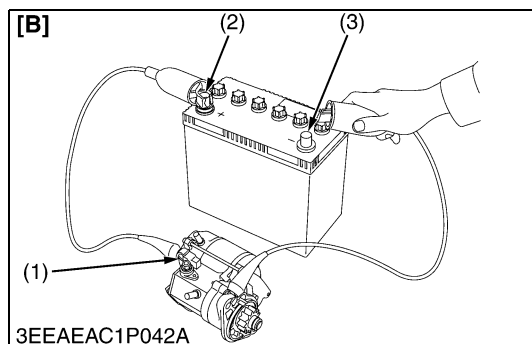
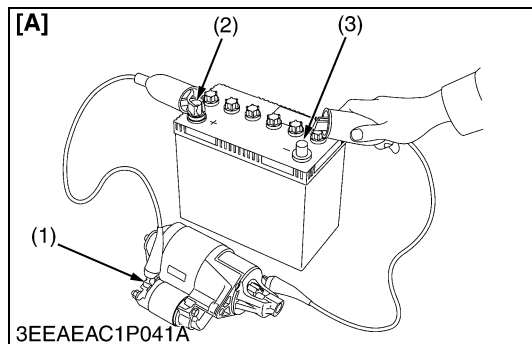

Magnetic Switch Test

1. Disconnect the battery negative cable from the battery.
2. Disconnect the battery positive cable from the battery.
3. Disconnect the leads from the starter **B** terminal.
4. Remove the starter from the engine.
5. Connect a jumper lead from the starter **S** terminal (1) to the battery positive terminal (2).
6. Connect a jumper lead momentarily between the starter's body and the battery negative terminal (3).
7. If the pinion gear does not pop out, the magnetic switch is failure. Repair or replace the starter.

NOTE

- **B terminal** : It is the terminal which connects the cable from the battery to the starter.
- **S terminal** : It is the terminal which connects the cable from the starter switch to the magnet switch.

- (1) S Terminal
 (2) Positive Terminal
 (3) Negative Terminal

[A] Electromagnetic Drive Type

[B] Planetary Gear Reduction Type

9Y1210785ENS0017US0

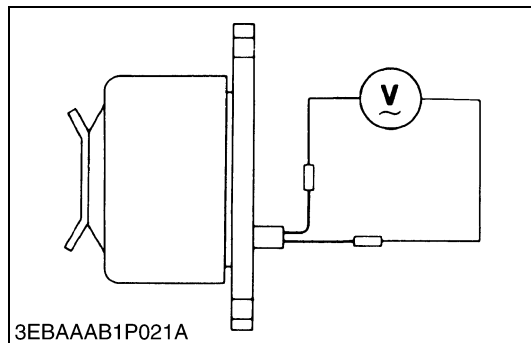
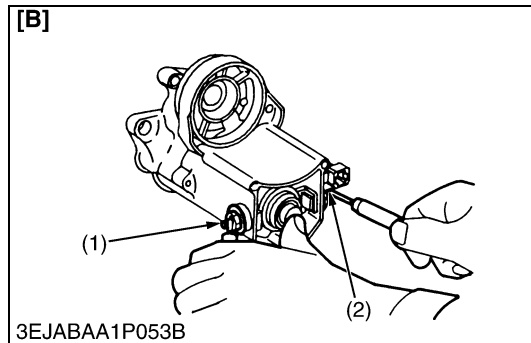
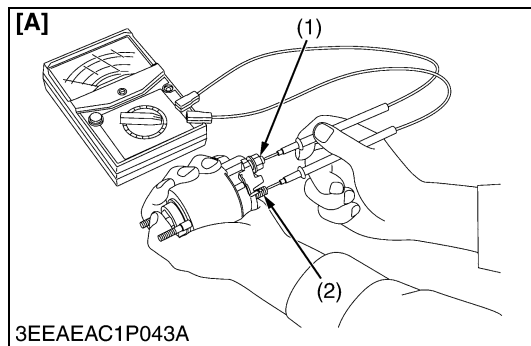

Magnet Switch Continuity Test

1. Check the continuity across the **C** terminal (1) and the **B** terminal (2) with a circuit tester, pushing in the plunger.
2. If not continuous or if a certain value is indicated, replace the magnet switch.

- (1) **C** Terminal
(2) **B** Terminal

- [A]** Electromagnetic Drive Type
[B] Planetary Gear Reduction Type

9Y1210785ENS0018US0

No-load Dynamo Output

1. Disconnect the lead wires from the dynamo.
2. Start the engine and operate the dynamo at the specified speed.
3. Measure the output voltage with a volt meter.
If the measurement is not within the specified values, replace the dynamo.

No-load output voltage	Factory specification	AC 20 V or more at 5200 min ⁻¹ (rpm)
------------------------	-----------------------	--

9Y1210785ENS0019US0

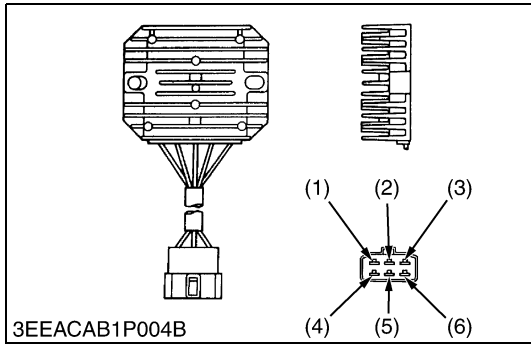

Continuity across Regulator's Terminals

1. Measure with a circuit tester according to the list below.

■ **NOTE**

- For this test, use only Analog Meter and do not use a high voltage tester such as a M Ω meter.
- This check sheet shows the results of the test conducted by using the "Sanwa-made tester SP-10 and SP-15D" (Analog Meter).
- Use of other testers than those above may show different measured results. Ω shall be used as the unit for the measuring range.
- The judgement should be as below table.
"ON" if the indicator moves, otherwise "OFF".

Check Table (★ : ON, ☆ : OFF)

		Code colors (Tester + Terminal)					
		Blue	Black	Blue	Green	Yellow	Red
Code colors (Tester - Terminal)	Blue		☆	☆	☆	☆	★
	Black	☆		☆	☆	☆	☆
	Blue	☆	☆		☆	☆	★
	Green	☆	☆	☆		☆	☆
	Yellow	★	★	★	☆		★
	Red	☆	☆	☆	☆	☆	

- | | |
|-----------|------------|
| (1) Blue | (4) Green |
| (2) Black | (5) Yellow |
| (3) Blue | (6) Red |

9Y1210785ENS0020US0

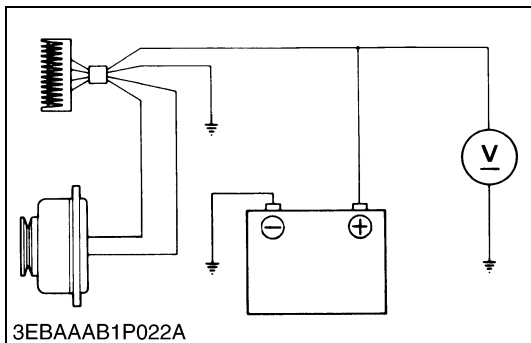

Regulating Voltage

1. Complete the charging circuit with a fully charged battery and operate the dynamo at the specified speed.
2. Measure the output voltage with a volt meter.
3. If the measurement is not within the specified values, replace the dynamo.

Regulating output voltage	Factory specification	14 to 15 V at 5200 min ⁻¹ (rpm)
---------------------------	-----------------------	--

9Y1210785ENS0021US0

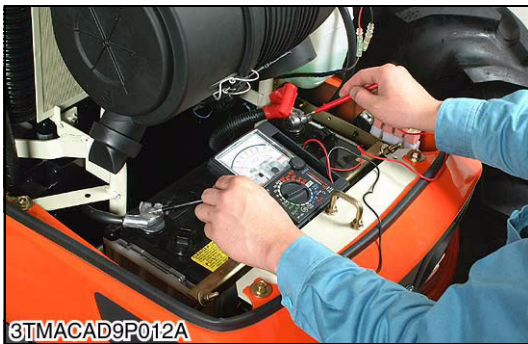

3TMACAD9P012A

Alternator on Unit Test

(Before testing)

- Before alternator on unit test, check the battery terminal connections, circuit connection, fan belt tension, charging indicator lamp, fuses on the circuit, and abnormal noise from the alternator.
- Prepare full charged battery for the test.

■ NOTE

- **Be careful not to touch the rotating engine parts while engine is running.**

Keep safety distance from the engine rotating parts.

1. Start the engine.
2. When the engine is operating measure the voltage between two battery terminals. If the voltage is between 13.8 V and 14.8 V, the alternator is operating normally.
3. If the results of alternator on unit test are not within the specifications, disassemble the alternator and check the each component part for finding out the failure. See the "DISASSEMBLING AND ASSEMBLING" and "SERVICING" for alternator.

Regulating voltage at no load	Factory specification	13.8 to 14.8 V at 25 °C (77 °F)
-------------------------------	-----------------------	---------------------------------

9Y1210785ENS0022US0

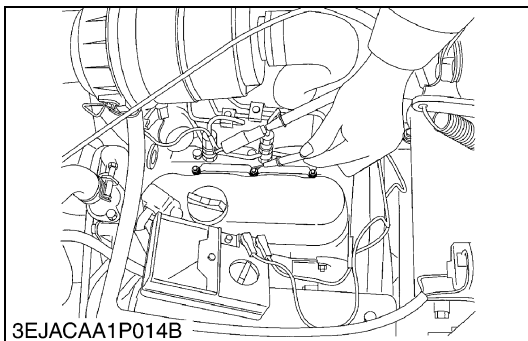

3EJACAA1P014B

Glow Plug Lead Terminal Voltage

1. Turn the key switch to the "**GLOW** (or **PREHEAT**)" position, and measure the voltage with a circuit tester between the lead terminal and the engine body.
2. If the voltage differs from the battery voltage, the wiring harness or main switch is faulty.

Voltage	Main switch key at GLOW (or PREHEAT)	Approx. battery voltage
---------	---	-------------------------

9Y1210785ENS0023US0

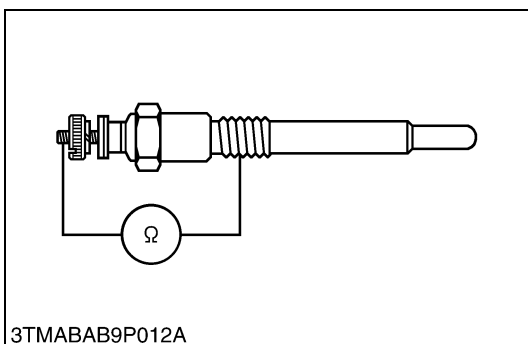

3TMABAB9P012A

Glow Plug Continuity

1. Remove the glow plug.
2. Measure the resistance with a circuit tester between the glow plug terminal and the glow plug housing.
3. If the factory specification is not indicated, glow plug is faulty.

Resistance	Factory specification	Approx. 1.1 Ω
------------	-----------------------	---------------

9Y1210785ENS0024US0

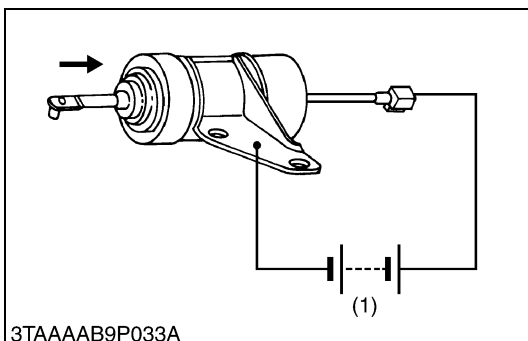

3TAAAB9P033A

Engine Stop Solenoid Test (Energize to Stop Type)

1. Disconnect the **1P** connector from the engine stop solenoid.
2. Remove the engine stop solenoid from the engine.
3. Connect the jumper leads from the battery positive terminal to the **1P** connector, and from the battery negative terminal to the engine stop solenoid body.
4. If the solenoid plunger is not attracted, the engine stop solenoid is faulty.

- (1) Battery (12 V)

9Y1210785ENS0025US0

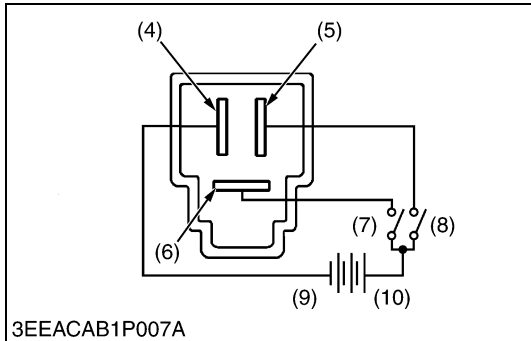
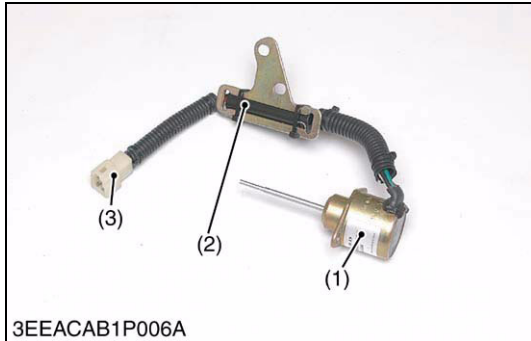
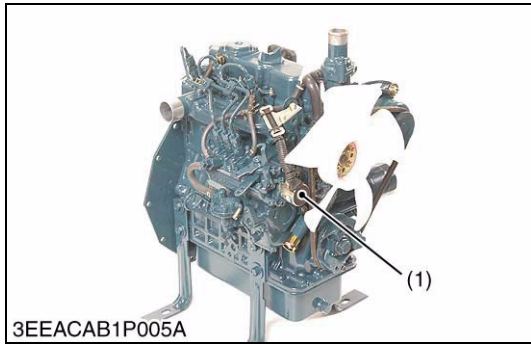

Engine Stop Solenoid Test (Energize to Run Type)

1. Disconnect the **3P** connector (3) from the engine stop solenoid (1) wiring harness.
2. Remove the engine stop solenoid (1) from the engine.
3. Connect the jumper leads from the pulling coil terminal (6) to the switch (7), and from switch (7) to the battery positive terminal (10).
4. Connect the jumper leads from the holding coil terminal (5) to the switch (8), and from switch (8) to the battery positive terminal (10).
5. Connect the jumper leads from the ground terminal (4) to the battery negative terminal (9).
6. When the switch (7) is turn on, the plunger pull into the solenoid body and then the plunger comes out within approximately 1.2 seconds.
7. Turn on the switch (8) then turn on the switch (7), the plunger pull into the solenoid body and it keeps in holding position after turn off the switch (7).
8. If the plunger is not attracted, the engine stop solenoid is faulty.

NOTE

- **This solenoid assembly includes reverse polarity protected pulling coil timer module (2) to prevent solenoid burnout due to engine over crank or misadjustment of linkage by limiting the pull coil ON time.**

Pull coil energized time	Factory specification	0.52 to 1.20 seconds
--------------------------	-----------------------	----------------------

- | | |
|-------------------------------|--------------------------------|
| (1) Engine Stop Solenoid | (6) Pulling Coil Terminal |
| (2) Pulling Coil Timer Module | (7) Switch for Pulling Coil |
| (3) 3P Connector | (8) Switch for Holding Coil |
| (4) Ground Terminal | (9) Battery Negative Terminal |
| (5) Holding Coil Terminal | (10) Battery Positive Terminal |

9Y1210785ENS0026US0

[2] DISASSEMBLING AND ASSEMBLING

(1) Draining Engine Oil and Coolant

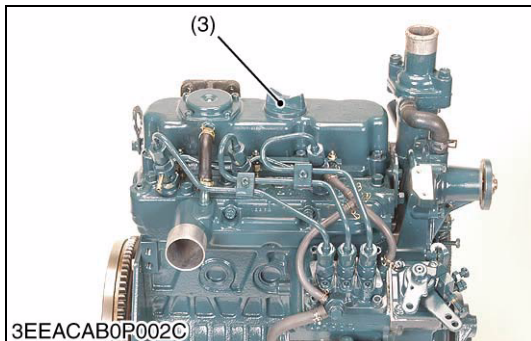
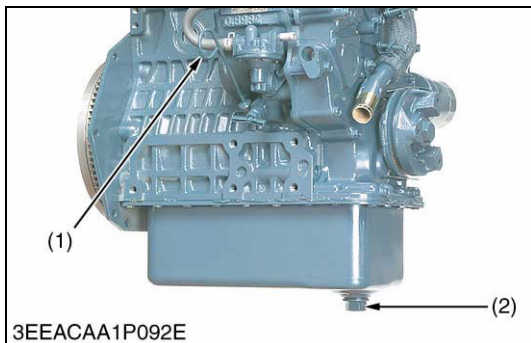

Draining Engine Oil

1. Start and warm up the engine for approx. 5 minutes.
2. Place an oil pan underneath the engine.
3. Remove the drain plug (2) to drain oil.
4. After draining, screw in the drain plug.

(When refilling)

- Fill the engine oil up to the upper line on the dipstick (1).

IMPORTANT

- **Never mix two different types of oil.**
- **Use the proper SAE Engine Oil according to ambient temperature.**

- | | |
|----------------|--------------------|
| (1) Dipstick | (3) Oil Inlet Plug |
| (2) Drain Plug | |

9Y1210785ENS0027US0

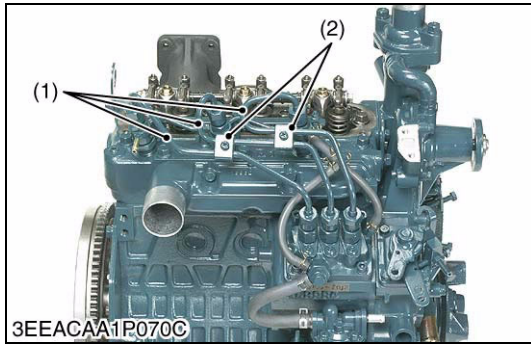

Injection Pipes

1. Loosen the screws to the pipe clamp (2).
2. Detach the injection pipes (1).

(When reassembling)

- Sent compressed air into the pipes to blow out dust. Then, reassemble the pipes in the reverse order.

Tightening torque	Injection pipe retaining nut	25 to 34 N·m 2.5 to 3.5 kgf·m 18 to 25 lbf·ft
-------------------	------------------------------	---

(1) Injection Pipe

(2) Pipe Clamp

9Y1210785ENS0031US0

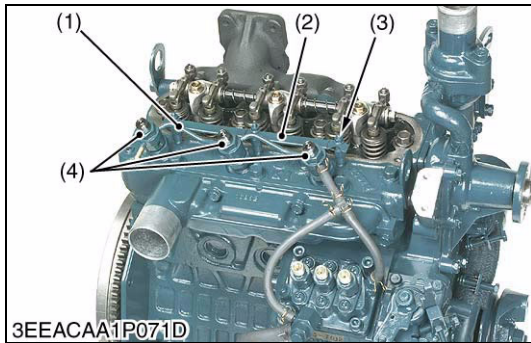

Nozzle Holder Assembly and Glow Plug

1. Remove the overflow pipe (1).
2. Remove the nozzle holder assemblies (4).
3. Remove the copper gasket (5) and heat seal (6).
4. Remove the lead (2) from the glow plugs (3).
5. Remove the glow plugs (3).

(When reassembling)

- Replace the copper gasket and heat seal with new one.

Tightening torque	Overflow pipe retaining nut	20 to 24 N·m 2.0 to 2.5 kgf·m 15 to 18 lbf·ft
	Nozzle holder assembly	49 to 68 N·m 5.0 to 7.0 kgf·m 37 to 50 lbf·ft
	Glow plug	7.9 to 14 N·m 0.80 to 1.5 kgf·m 5.8 to 10 lbf·ft

(1) Overflow Pipe

(4) Nozzle Holder Assembly

(2) Lead

(5) Copper Gasket

(3) Glow Plug

(6) Heat Seal

9Y1210785ENS0032US0

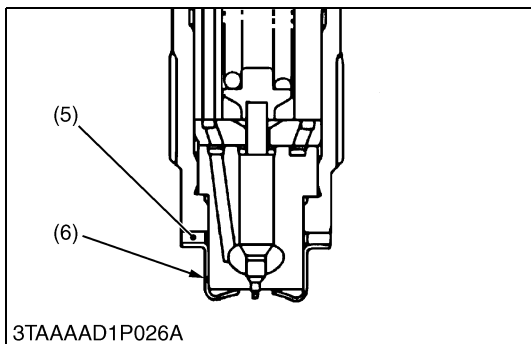

Nozzle Heat Seal Service Removal Procedure

■ IMPORTANT

- Use a plus (phillips head) screw driver (1) that has a diameter which is bigger than the heat seal hole (Approx. 6.0 mm (0.24 in.)).

1. Drive screw driver (1) lightly into the heat seal hole.
2. Turn screw driver three or four times each way.
3. While turning the screw driver, slowly pull the heat seal (4) out together with the injection nozzle gasket (3).
4. If the heat seal drops, repeat the above procedure.

(When reassembling)

- Heat seal and injection nozzle gasket must be changed when the injection nozzle is removed for cleaning or for service.

(1) Plus Screw Driver

(3) Injection Nozzle Gasket

(2) Injection Nozzle

(4) Heat Seal

9Y1210785ENS0033US0

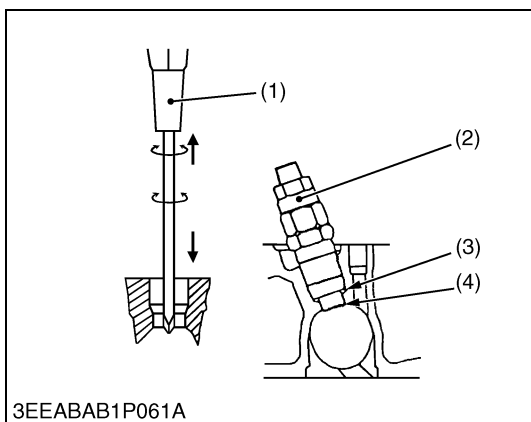

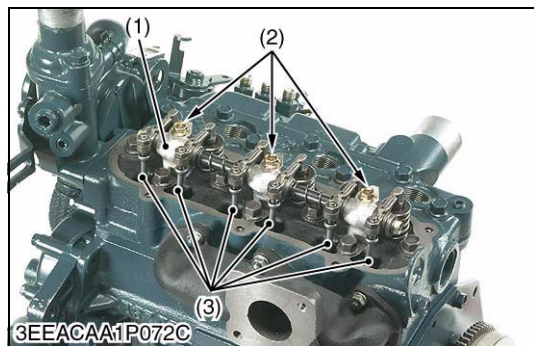

Rocker Arm and Push Rod

1. Remove the rocker arm bracket screws (2).
2. Detach the rocker arm assembly (1).
3. Remove the push rods (3).

(When reassembling)

- When putting the push rods (3) onto the tappets (4), check to see if their ends are properly engaged with the dimples.

■ IMPORTANT

- **After installing the rocker arm, be sure to adjust the valve clearance.**

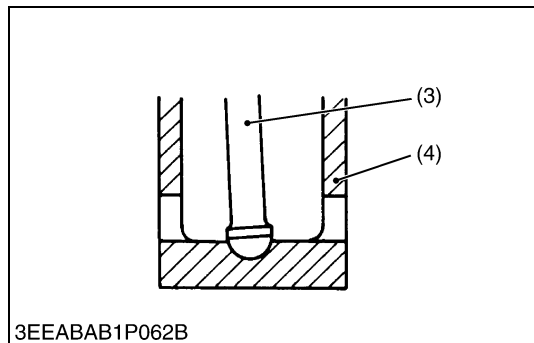

Tightening torque	Rocker arm bracket screw	9.81 to 11.2 N·m 1.00 to 1.15 kgf·m 7.24 to 8.31 lbf·ft
-------------------	--------------------------	---

- (1) Rocker Arm Assembly (3) Push Rod
(2) Rocker Arm Bracket Screws (4) Tappet

9Y1210785ENS0034US0

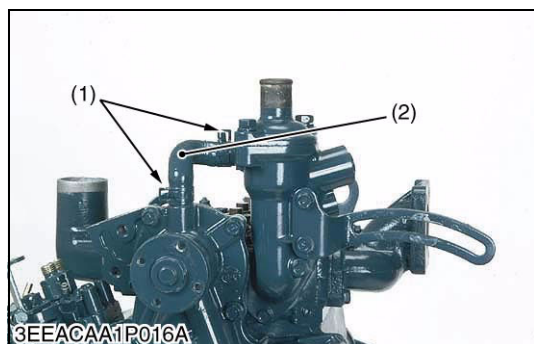

Cylinder Head and Cylinder Head Gasket

1. Loosen the pipe clamps (1), and remove the water return pipe (2).
2. Remove the cylinder head screw in the order of (n or j) to (a).
3. Remove the cylinder head gasket.

(When reassembling)

- Replace the cylinder head gasket with a new one.
- When mounting the gasket, set it to the pin pipe holes. Take care not to mount it reversely.
- The cylinder head should be free of scratches and dust.
- Install the cylinder head, using care not to damage the gasket.
- After applying engine oil to the thread of screws, tighten them in several steps and specified sequence (a) to (n or j).

■ NOTE

- **Do not use O-ring on the pin pipe.**
- **It is not necessary to retighten the cylinder head screw and to readjust valve clearance after engine warmed up.**

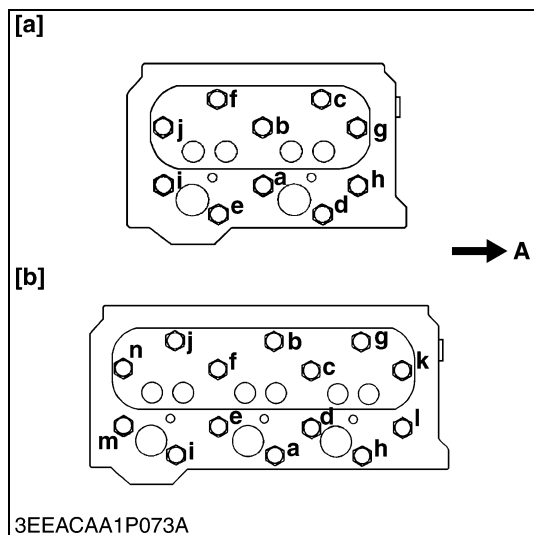

Tightening torque	Cylinder head screw	38 to 42 N·m 3.8 to 4.3 kgf·m 28 to 31 lbf·ft
-------------------	---------------------	---

- (1) Pipe Clamp
(2) Water Return Pipe
(3) Pin Pipe

A : Gear Case Side
(n or j) to (a) : To Loosen
(a) to (n or j) : To Tighten
[a] Z482-E4B, Z602-E4B
[b] D722-E4B, D782-E4B, D902-E4B

9Y1210785ENS0035US0

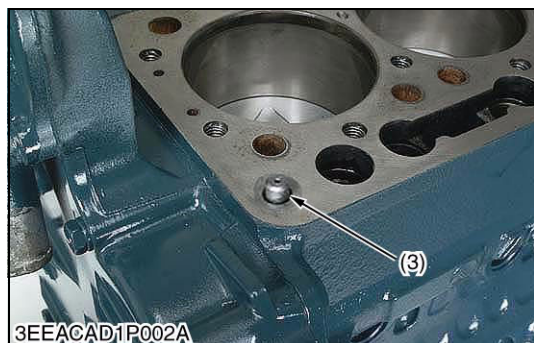

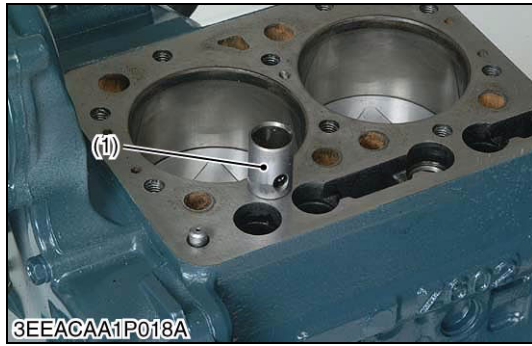

Tappets

1. Remove the tappets (1) from the crankcase.

(When reassembling)

- Visually check the contact between tappets and cams for proper rotation. If defect is found, replace tappets.
- Before installing the tappets, apply engine oil thinly around them.

■ **IMPORTANT**

- **Do not change the combination of tappet and tappet guide.**

(1) Tappet

9Y1210785ENS0036US0

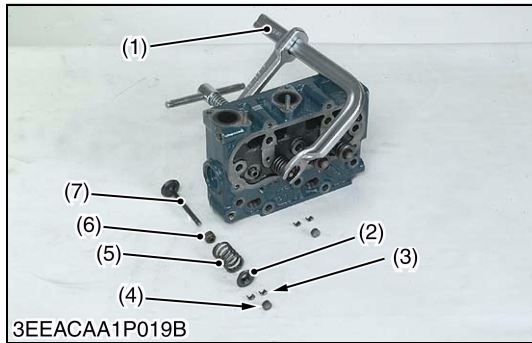

Valves

1. Remove the valve caps (4).
2. Remove the valve spring collet (3), pushing the valve spring retainer (2) by valve spring replacer (1).
3. Remove the valve spring retainer (2), valve spring (5) and valve stem seal (6).
4. Remove the valve (7).

(When reassembling)

- Wash the valve stem and valve guide hole, and apply engine oil sufficiently.
- After installing the valve spring collets, lightly tap the stem to assure proper fit with a plastic hammer.

■ **IMPORTANT**

- **Do not change the combination of valve and valve guide.**

(1) Valve Spring Replacer

(2) Valve Spring Retainer

(3) Valve Spring Collet

(4) Valve Cap

(5) Valve Spring

(6) Valve Stem Seal

(7) Valve

9Y1210785ENS0037US0

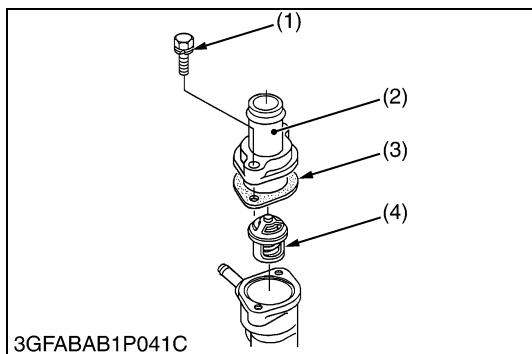

Thermostat Assembly

1. Remove the thermostat cover mounting screws (1), and remove the thermostat cover (2).
2. Remove the thermostat assembly (4).

(When reassembling)

- Replace the gasket (3) with a new one.

(1) Thermostat Cover Mounting Screw

(2) Thermostat Cover

(3) Thermostat Cover Gasket

(4) Thermostat Assembly

9Y1210785ENS0038US0

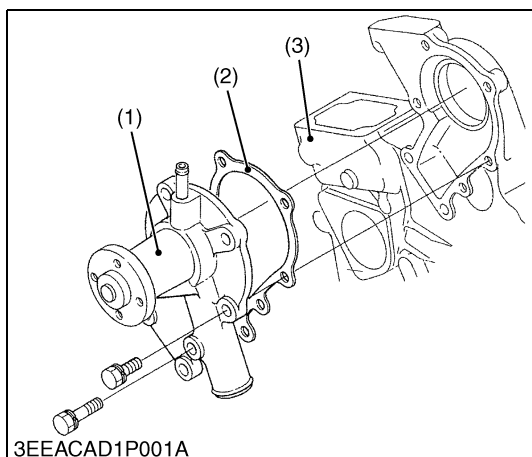

Water Pump Assembly (If necessary)

1. Loosen the alternator mounting screws, and remove the fan belt.
2. Remove the fan and fan pulley.
3. Remove the water pump assembly (1) from the gear case cover (3).

(When reassembling)

- Replace the gasket (2) with a new one.

(1) Water Pump Assembly

(2) Water Pump Gasket

(3) Gear Case Cover

9Y1210785ENS0039US0

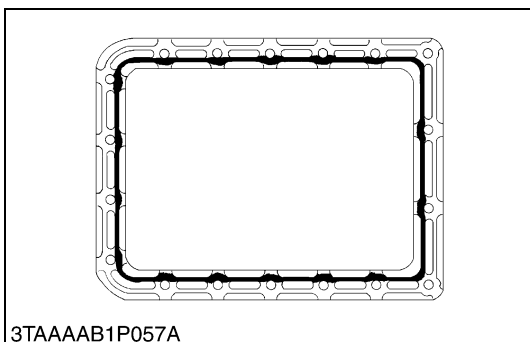
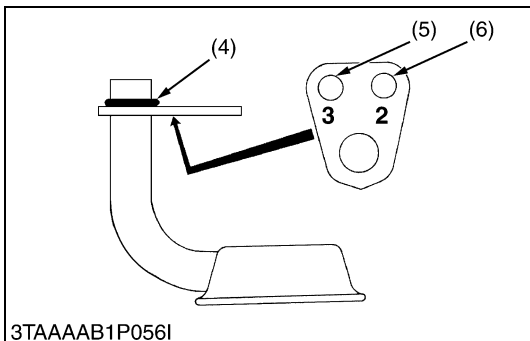
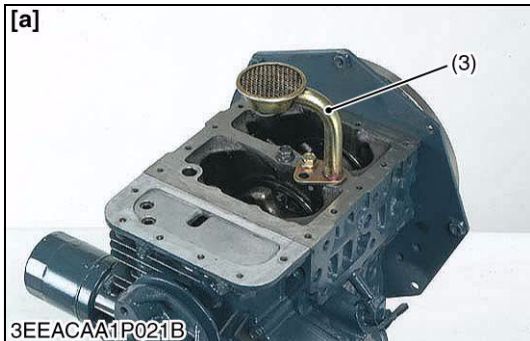
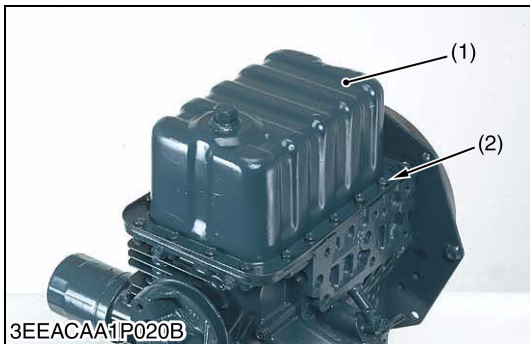

Oil Pan and Oil Strainer

1. Remove the oil pan mounting screws (2).
2. Remove the oil pan (1) by lightly tapping the rim of the pan with a wooden hammer.
3. Remove the oil strainer (3).

(When reassembling)

- After cleaning the oil strainer, check to see that the filter mesh is clean, and install it.
- Visually check the O-ring (4), apply engine oil, and install it.
- Securely fit the O-ring to the oil strainer.
- To avoid uneven tightening, tighten oil pan mounting screws in diagonal order from the center.

For Z482-E4B, Z602-E4B

- Using the hole (6) numbered "2", install the oil strainer by mounting screw.

For D722-E4B, D782-E4B, D902-E4B

- Using the hole (5) numbered "3", install the oil strainer by mounting screw.

■ IMPORTANT

- **Scrape off the old adhesive completely. Wipe the sealing surface clean using waste cloth soaked with gasoline. Now apply new adhesive 3.0 to 5.0 mm (0.12 to 0.19 in.) thick all over the contact surface. Apply the adhesive also on the center of the flange as well as on the inner wall of each bolt hole.**
- **Cut the nozzle of the "liquid gasket" (Three Bond 1207D or equivalent) container at its second notch. Apply "liquid gasket" about 3.0 to 5.0 mm (0.12 to 0.19 in.) thick. Within 20 minutes after the application of fluid sealant, reassemble the components. Wait then for about 30 minutes, and pour oil in the crankcase.**

- | | |
|----------------------------|----------------------------------|
| (1) Oil Pan | [a] Z482-E4B, Z602-E4B |
| (2) Oil Pan Mounting Screw | [b] D722-E4B, D782-E4B, D902-E4B |
| (3) Oil Strainer | |
| (4) O-ring | |
| (5) Hole Numbered "3" | |
| (6) Hole Numbered "2" | |

9Y1210785ENS0040US0

(4) Gear Case and Timing Gears

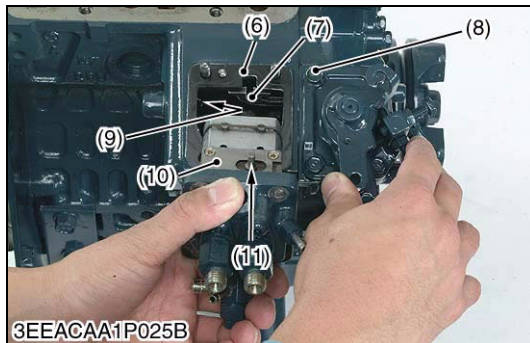
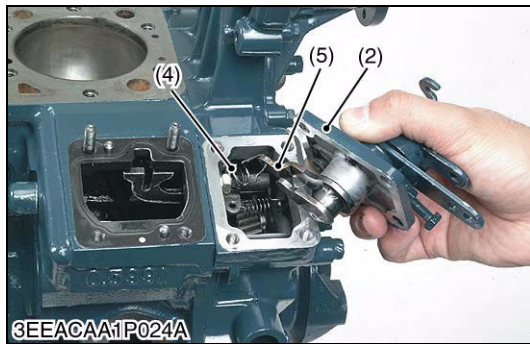
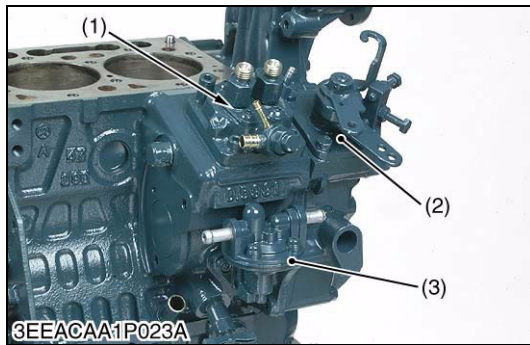

Injection Pump, Fuel Feed Pump and Speed Control Plate (for Energize to Stop Type Engine Stop Solenoid)

1. Remove the socket head screws and nuts, and remove the injection pump (1).
2. Remove the screws and separate the speed control plate (2), taking care not to damage the governor spring (4).
3. Disconnect the governor spring (4) and remove the speed control plate (2).
4. Remove the fuel feed pump (3).

(When reassembling)

- Hook the governor spring (4) to the governor lever (5) first and install the speed control plate (2).
- Be sure to place the copper washers underneath two screws (8). (Two screws (8) in the upper of the speed control plate (2).)
- Position the slot (7) on the fork lever just under the slot (6) on the crankcase.
- Insert the injection pump (1) so that the control rod (10) should be pushed by the idling adjusting spring (9) at its end and the pin (11) on the rod engages with the slot (7) on the fork lever (as shown in the photo).

■ **NOTE**

- **The sealant is applied to both sides of the soft metal gasket shim. The liquid gasket is not required for assembling.**
- **Addition or reduction of shim (0.05 mm, 0.002 in.) delays or advances the injection timing by approx. 0.009 rad (0.5 °).**
- **In disassembling and replacing, be sure to use the same number of new gasket shims with the same thickness.**

- | | |
|---------------------------|-----------------------------|
| (1) Injection Pump | (7) Slot (Fork Lever Side) |
| (2) Speed Control Plate | (8) Screw and Copper Washer |
| (3) Fuel Feed Pump | (9) Idling Adjusting Spring |
| (4) Governor Spring | (10) Control Rod |
| (5) Governor Lever | (11) Pin |
| (6) Slot (Crankcase Side) | |

(To be continued)

(Continued)

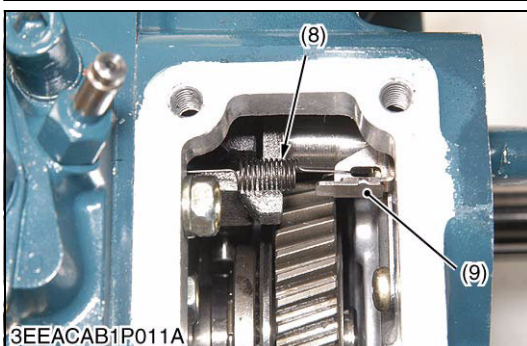
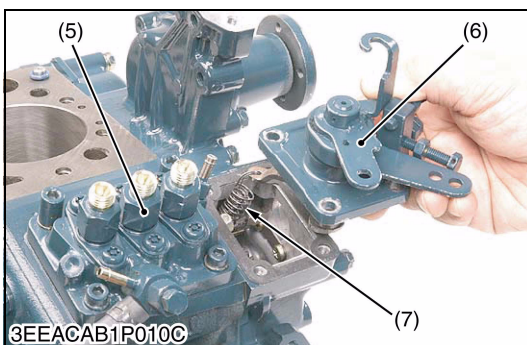
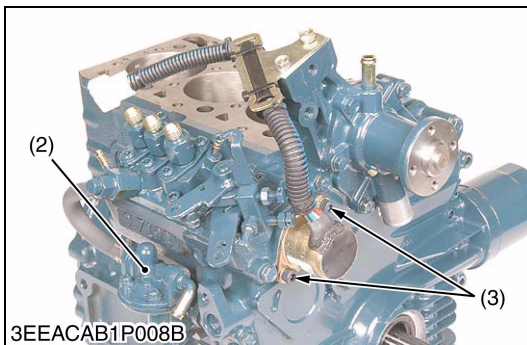
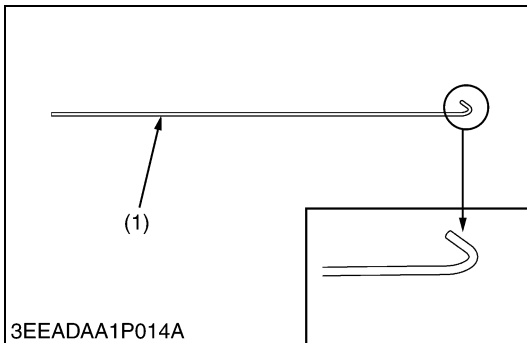

■ **NOTE**

- **Specific tool (1) :**
1.2 mm (0.047 in.) diameter hard wire with its end hooked, overall length 200 mm (7.87 in.).
The tip of wire is bent like the hook to hang governor springs.

1. Remove the socket head screws (3), and remove the engine stop solenoid (4).
2. Remove the screws and separate the speed control plate (6), taking care not to damage the governor spring (7).
3. Disconnect the governor spring (7) and remove the speed control plate (6) using the specific tool (1).
4. Remove the fuel feed pump (2).
5. Disconnect the start spring (8) from the bracket (9) using the specific tool (1).
6. Remove the socket head screws and nuts, and remove the injection pump (5).

- | | |
|--------------------------|-------------------------|
| (1) Specific Tool | (6) Speed Control Plate |
| (2) Fuel Feed Pump | (7) Governor Spring |
| (3) Socket Head Screw | (8) Start Spring |
| (4) Engine Stop Solenoid | (9) Bracket |
| (5) Injection Pump | |

(To be continued)

(Continued)

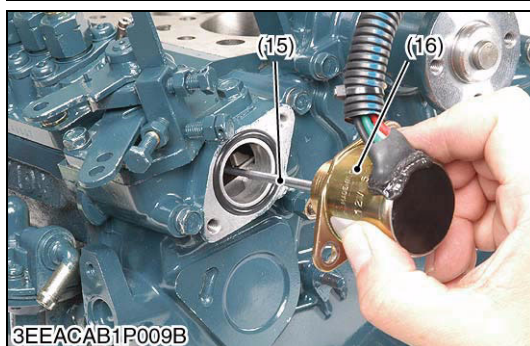
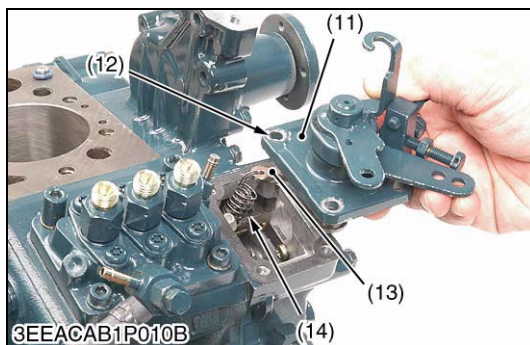
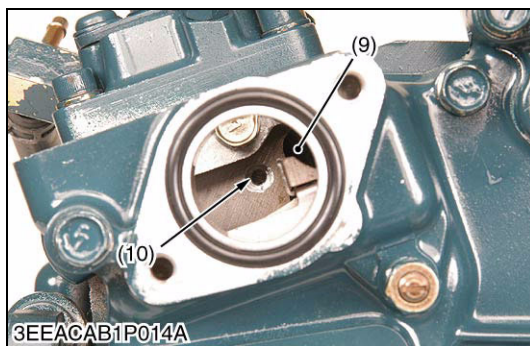
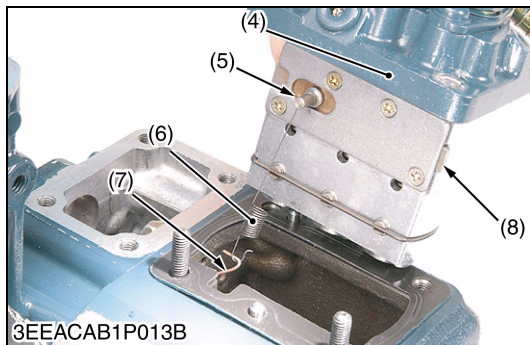
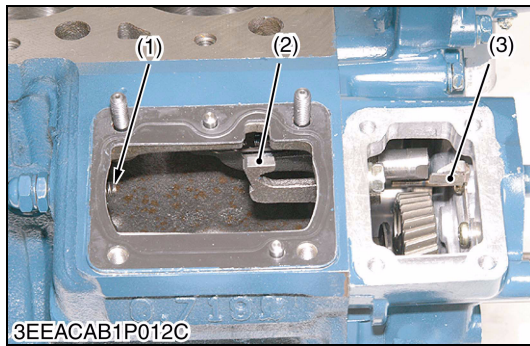
**(When reassembling)**

1. Move the fork lever (2) to the gear case side.
2. Hook the start spring (6) to the injection pump control rack pin (5).
3. Put the specific tool (7) through the fork lever hole of cylinder block (9) and hook the start spring (6).
4. Keep this spring slightly extended and install the injection pump (4). Make sure the control rod (8) should be pushed by the idling adjusting spring (1) and the pin (5) on the rod engages with the fork lever (2).
5. Hook the start spring (6) to the bracket (3) using the specific tool (7).
6. Hook the governor springs (small and large) (14) to the governor lever (13) using the specific tool (7) and install the speed control plate (11). Be sure to place the copper washers underneath two screws (12) in the upper of the speed control plate.
7. Install the engine stop solenoid rod (15) to the guide hole of cylinder block (10) and fix the engine stop solenoid (16) with socket head screws.

NOTE

- Be careful not to stretch the start spring (6) too long. Otherwise it may get deformed permanently.
- Make sure the start spring (6) is tight on the bracket (3).
- The sealant is applied to both sides of the soft metal gasket shim. The liquid gasket is not required for assembling.
- Addition or reduction of shim (0.05 mm, 0.002 in.) delays or advances the injection timing by approx. 0.009 rad (0.5 °).
- In disassembling and replacing, be sure to use the same number of new gasket shims with the same thickness.

- | | |
|-------------------------------------|---------------------------------------|
| (1) Idling Adjusting Spring | (9) Fork Lever Hole of Cylinder Block |
| (2) Fork Lever | (10) Guide Hole of Cylinder Block |
| (3) Bracket | (11) Speed Control Plate |
| (4) Injection Pump | (12) Screw and Copper Washer |
| (5) Injection Pump Control Rack Pin | (13) Governor Lever |
| (6) Start Spring | (14) Governor Spring |
| (7) Specific Tool | (15) Engine Stop Solenoid Rod |
| (8) Injection Pump Control Rod | (16) Engine Stop Solenoid |

9Y1210785ENS0041US0

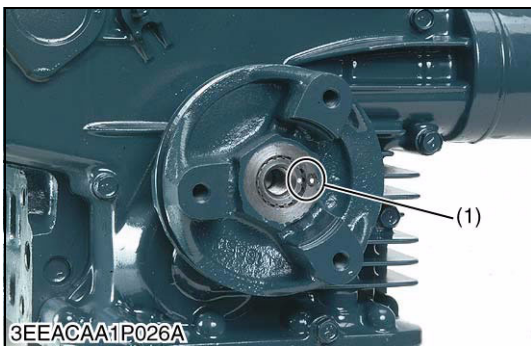

Fan Drive Pulley

1. Secure the flywheel to keep it from turning.
2. Remove the fan drive pulley screw.
3. Draw out the fan drive pulley with a puller.

(When reassembling)

- Install the pulley to crankshaft, aligning the mark (1) on them.
- Apply engine oil to the fan drive pulley retaining screw. And tighten it.

Tightening torque	Fan drive pulley screw	118 to 127 N·m 12.0 to 13.0 kgf·m 86.8 to 94.0 lbf·ft
-------------------	------------------------	---

(1) Alignment Mark

9Y1210785ENS0042US0

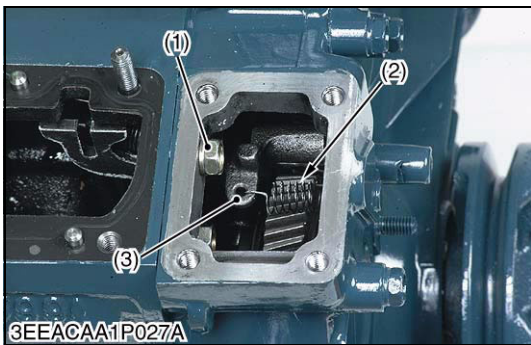

Gear Case

1. Disconnect the start spring (2) from the fork lever 1 (3).
2. Remove the screw (1) of inside the gear case and outside screws.
3. Remove the gear case (4).

(When reassembling)

- Apply a liquid gasket (Three Bond 1215 or equivalent) to both sides of the gear case gasket.
- Be sure to set three O-rings inside the gear case.

NOTE

- **The gear case for energize to run type stop solenoid and the gear case for one-side maintenance are available to meet customer's requirements. (Option)**

- (1) Screw (Inside)
- (2) Start Spring
- (3) Fork Lever 1
- (4) Gear Case

- [a] Gear Case for Energize to Run Type Stop Solenoid (Option)
- [b] Gear Case for One-side Maintenance (Option)

9Y1210785ENS0043US0

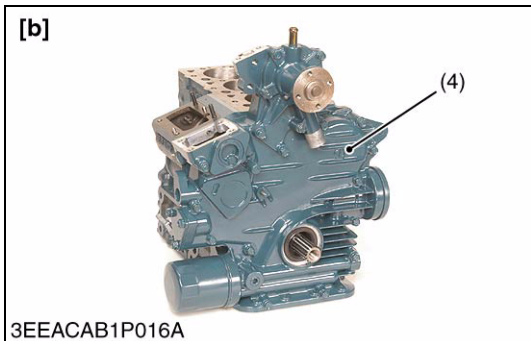
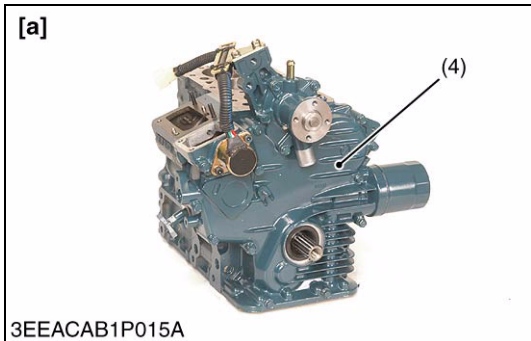
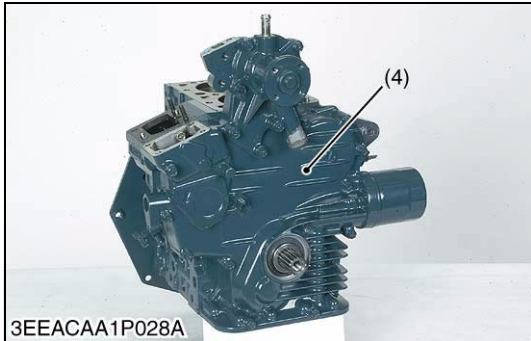

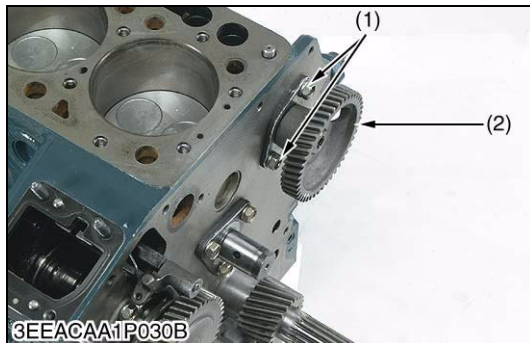
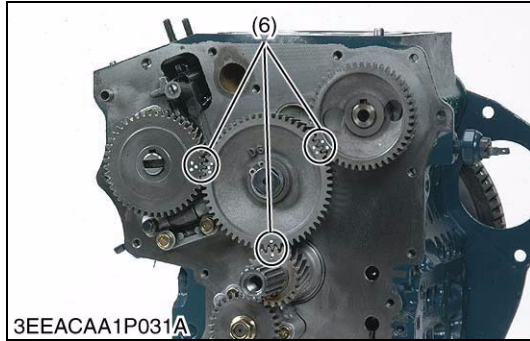
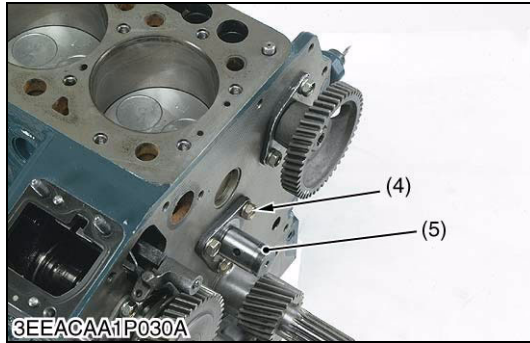
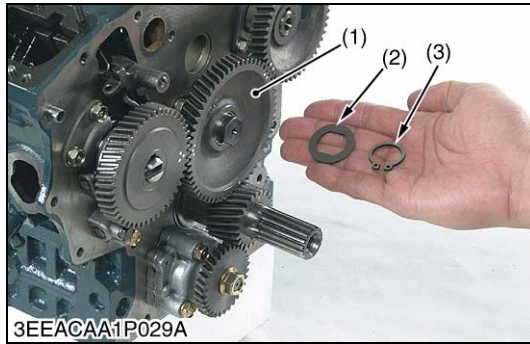

Idle Gear

1. Remove the external snap ring (3), the collar (2) and the idle gear (1).
2. Remove the idle gear shaft mounting screws (4).
3. Remove the idle gear shaft (5) (if necessary).

(When reassembling)

- Apply engine oil to the idle gear shaft mounting screw (4). And tighten them.
- Install the idle gear, aligning the mark (6) on the gears referring to the photo.

Tightening torque	Idle gear shaft mounting screw	9.81 to 11.2 N·m 1.00 to 1.15 kgf·m 7.24 to 8.31 lbf·ft
-------------------	--------------------------------	---

- | | |
|------------------------|------------------------------------|
| (1) Idle Gear | (4) Idle Gear Shaft Mounting Screw |
| (2) Idle Gear Collar | (5) Idle Gear Shaft |
| (3) External Snap Ring | (6) Alignment Mark |

9Y1210785ENS0044US0

Camshaft

1. Remove the camshaft mounting screws (1) and draw out the camshaft with gear (2) on it.

(When reassembling)

- When install the camshaft, apply engine oil to the camshaft journals.
- Apply engine oil to the camshaft mounting screws. And tighten them.

- | | |
|-----------------------------|-------------------|
| (1) Camshaft Mounting Screw | (2) Camshaft Gear |
|-----------------------------|-------------------|

9Y1210785ENS0045US0

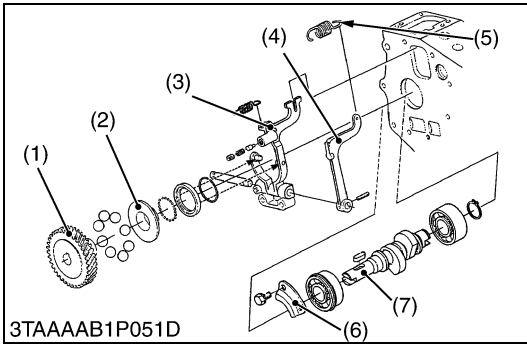

3TAAAB1P051D

Fuel Camshaft

1. Remove the retaining plate (6).
2. Remove the fork lever holder mounting screws (8), then draw out the injection pump gear (1) and fuel camshaft (7) with the governor fork assembly.

(When reassembling)

- Hook the governor spring (5) to the fork lever 2 (4) before installing the fork lever assembly to the crankcase.

- | | |
|-------------------------|--------------------------------------|
| (1) Injection Pump Gear | (5) Governor Spring |
| (2) Governor Sleeve | (6) Retaining Plate |
| (3) Fork Lever 1 | (7) Fuel Camshaft |
| (4) Fork Lever 2 | (8) Fork Lever Holder Mounting Screw |

9Y1210785ENS0046US0

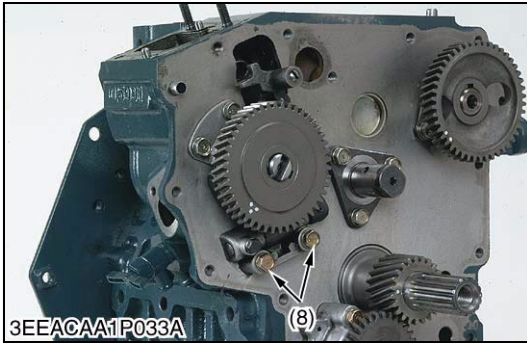

3EEACAA1P033A

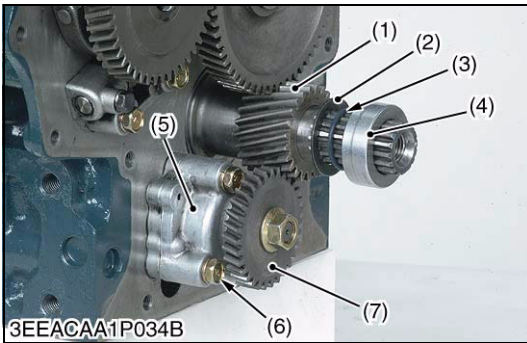

3EEACAA1P034B

Oil Pump and Crankshaft Gear

1. Remove the oil pump gear (7).
2. Remove the oil pump mounting screw (6) and the oil pump (5).
3. Remove the collar (4), O-ring (3) and crankshaft oil slinger (2).

For Z482-E4B, D722-E4B, D782-E4B

4. Remove the crankshaft gear (1) with a puller.

(When reassembling)

- Install the collar (4) after aligning the marks on the gears. (See the photo at "Idle Gear".)

Tightening torque	Oil pump mounting screw	18 to 21 N·m 1.8 to 2.2 kgf·m 13 to 15 lbf·ft
-------------------	-------------------------	---

- | | |
|----------------------------|-----------------------------|
| (1) Crankshaft Gear | (5) Oil Pump |
| (2) Crankshaft Oil Slinger | (6) Oil Pump Mounting Screw |
| (3) O-ring | (7) Oil Pump Gear |
| (4) Crankshaft Collar | |

9Y1210785ENS0047US0

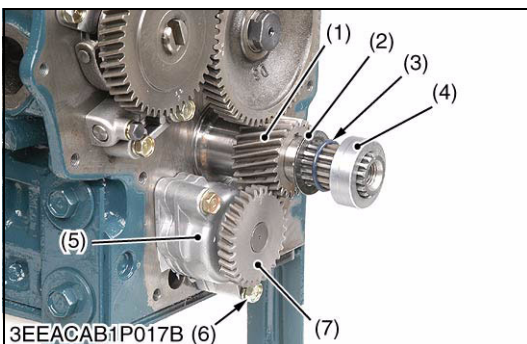

3EEACAB1P017B

Oil Pump and Crankshaft Gear (One-side Maintenance Type)

1. Remove the oil pump mounting screw (6) and the oil pump (5).
2. Remove the collar (4), O-ring (3) and crankshaft oil slinger (2).

For Z482-E4B, D722-E4B, D782-E4B

3. Remove the crankshaft gear (1) with a puller.

(When reassembling)

- Install the collar (4) after aligning the marks on the gears. (See the photo at "Idle Gear".)

Tightening torque	Oil pump mounting screw	18 to 21 N·m 1.8 to 2.2 kgf·m 13 to 15 lbf·ft
-------------------	-------------------------	---

- | | |
|----------------------------|-----------------------------|
| (1) Crankshaft Gear | (5) Oil Pump |
| (2) Crankshaft Oil Slinger | (6) Oil Pump Mounting Screw |
| (3) O-ring | (7) Oil Pump Gear |
| (4) Crankshaft Collar | |

9Y1210785ENS0048US0

(5) Piston and Connecting Rod

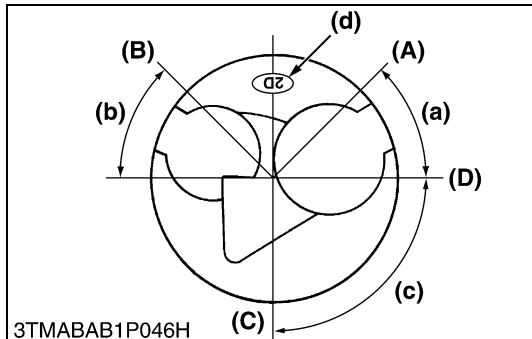
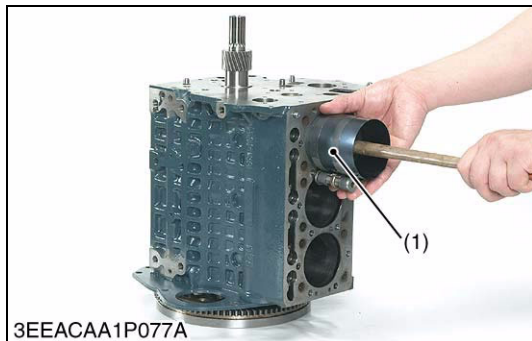
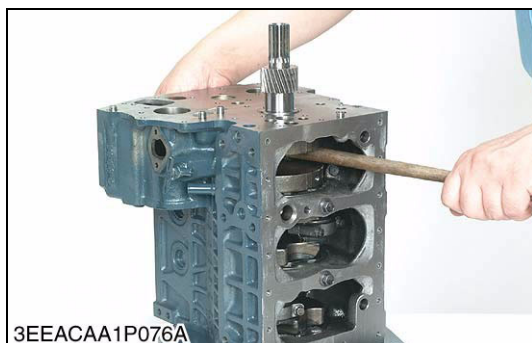
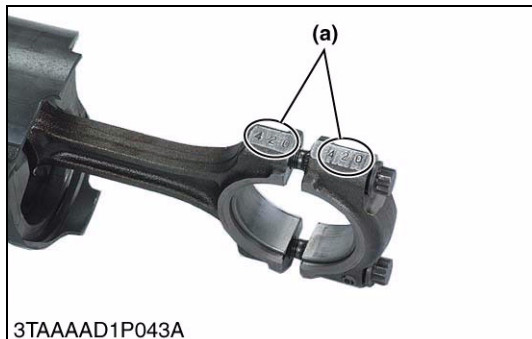
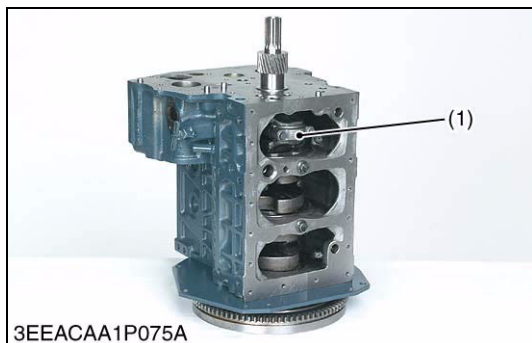

Connecting Rod Cap

1. Remove the connecting rod caps (1) using a bihexagonal 8 mm socket.

(When reassembling)

- Align the marks (a) with each other. (Face the marks toward the injection pump.)
- Apply engine oil to the connecting rod screws and lightly screw it in by hand, then tighten it to the specified torque.
If the connecting rod screw won't be screwed in smoothly, clean the threads.
If the connecting rod screw is still hard to screw in, replace it.

Tightening torque	Connecting rod screw	27 to 30 N·m 2.7 to 3.1 kgf·m 20 to 22 lbf·ft
-------------------	----------------------	---

(1) Connecting Rod Cap

(a) Mark

9Y1210785ENS0049US0

Piston

1. Turn the flywheel and bring the piston to top dead center.
2. Draw out the piston upward by lightly tapping it from the bottom of the crankcase with the grip of a hammer.
3. Draw out the other pistons after the same method as above.

(When reassembling)

- Before inserting the piston into the cylinder, apply enough engine oil to the cylinder.
- When inserting the piston into the cylinder, face the mark on the connecting rod to the injection pump.

■ IMPORTANT

- Do not change the combination of cylinder and piston. Make sure of the position of each piston by marking. For example, mark "1" on the No. 1 piston.
- When installing the piston into the cylinder, place the gaps of all of the piston rings as shown in the figure.
- Carefully insert the piston using a piston ring compressor (1). Otherwise, their chrome-plated section may be scratched, causing trouble inside the cylinder.

Models	Mark
Z482-E4B, D722-E4B	3
D782-E4B	B
Z602-E4B, D902-E4B (3200 min ⁻¹ (rpm) spec.)	1C
Z602-E4B, D902-E4B (3600 min ⁻¹ (rpm) spec.)	2D

(1) Piston Ring Compressor

(a) 0.79 rad (45°)

(b) 0.79 rad (45°)

(c) 1.6 rad (90°)

(d) Mark

(A) Top Ring Gap

(B) Second Ring Gap

(C) Oil Ring Gap

(D) Piston Pin Hole

9Y1210785ENS0050US0

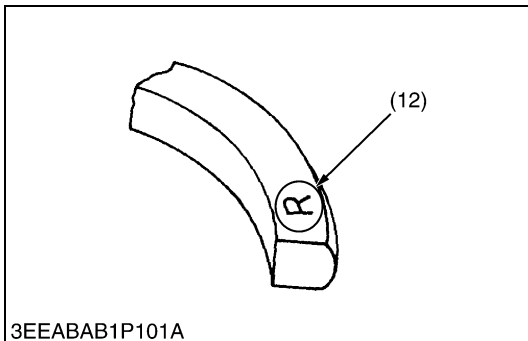
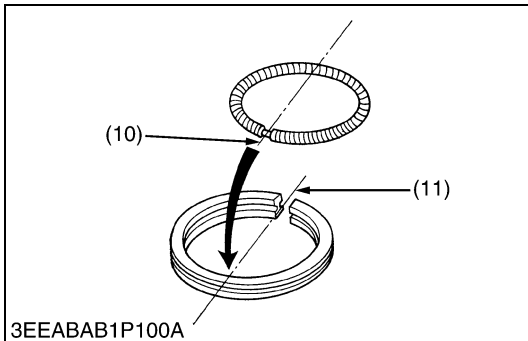
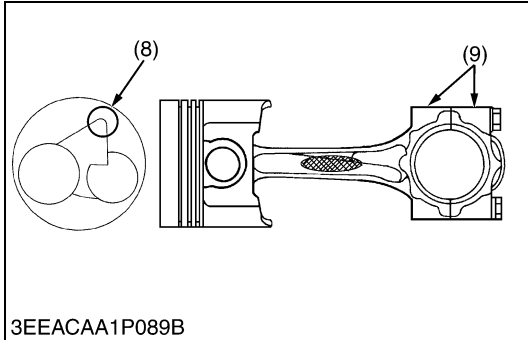
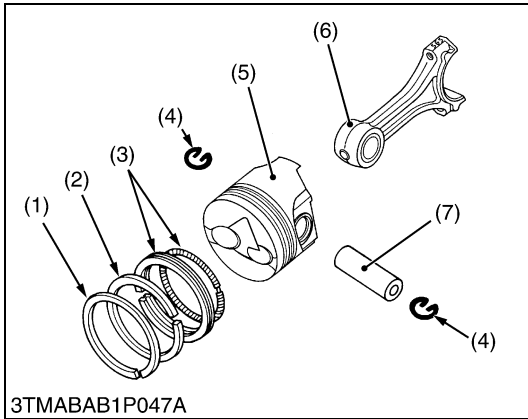

Piston Ring and Connecting Rod

1. Remove the piston rings using a piston ring tool.
2. Remove the piston pin (7), and separate the connecting rod (6) from the piston (5).

(When reassembling)

- When installing the ring, assemble the rings so that the manufacturer's mark (12) near the gap faces the top of the piston.
- When installing the oil ring onto the piston, place the expander joint (10) on the opposite side of the oil ring gap (11).
- Apply engine oil to the piston pin.
- When installing the connecting rod to the piston, immerse the piston in 80 °C (176 °F) oil for 10 to 15 minutes and insert the piston pin to the piston.
- When installing the connecting rod to the piston, align the mark (9) on the connecting rod to the fan-shaped concave (8).

■ **IMPORTANT**

- **Mark the same number on the connecting rod and the piston so as not to change the combination.**

- | | |
|--------------------------|--------------------------|
| (1) Top Ring | (7) Piston Pin |
| (2) Second Ring | (8) Fan-Shaped Concave |
| (3) Oil Ring | (9) Mark |
| (4) Piston Pin Snap Ring | (10) Expander Joint |
| (5) Piston | (11) Oil Ring Gap |
| (6) Connecting Rod | (12) Manufacturer's Mark |

9Y1210785ENS0051US0

(6) Flywheel and Crankshaft

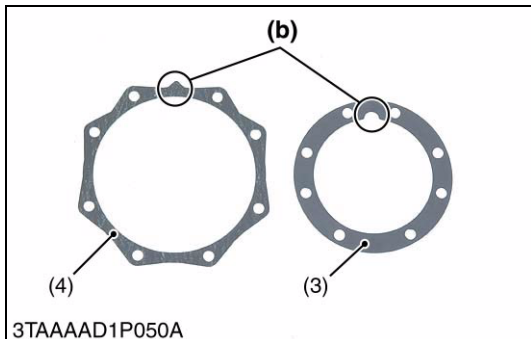
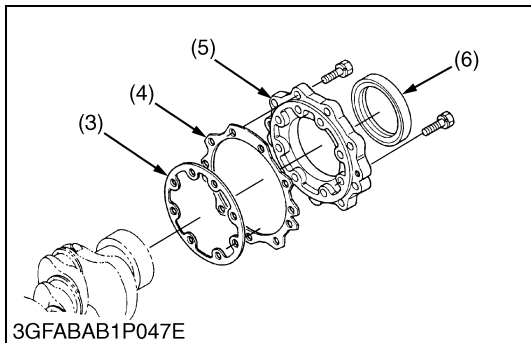
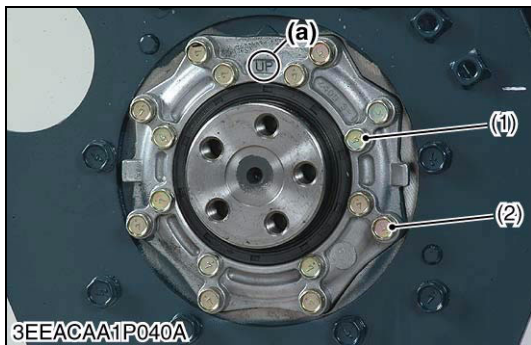
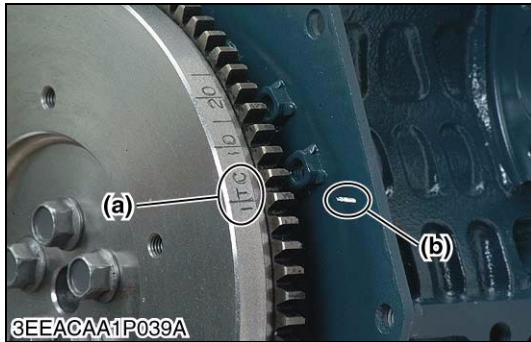
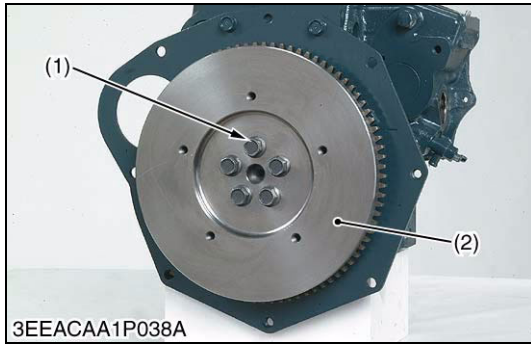

Flywheel

1. Secure the flywheel to keep it from turning using a flywheel stopper. (Refer to "SPECIAL TOOLS".)
2. Remove all flywheel screws (1) and then remove the flywheel (2).

(When reassembling)

- Set the No. 1 crankpin at the top dead center (T.D.C.).
- Align the "1TC" mark (a) on the outer surface of the flywheel horizontally with the alignment mark (b) on the rear end plate.
- Apply engine oil to the threads and the undercut surface of the flywheel screw and fit the screw.

Tightening torque	Flywheel screw	54 to 58 N·m 5.5 to 6.0 kgf·m 40 to 43 lbf·ft
-------------------	----------------	---

- (1) Flywheel Screw
- (2) Flywheel

- (a) 1TC Mark
- (b) Alignment Mark

9Y1210785ENS0052US0

Bearing Case Cover

1. Remove the bearing case cover mounting screws. First, remove inside screws (1) and then outside screws (2).
2. Remove the bearing case cover (5).

(When reassembling)

- Fit the bearing case gasket (3) and the bearing case cover gasket (4) with correct directions.
- Install the bearing case cover (5) to position the casting mark "UP" (a) on it upward.
- Apply engine oil to the oil seal (6) lip and take care that it is not rolled when installing.
- Tighten the bearing case cover mounting screws with even force on the diagonal line.

Tightening torque	Bearing case cover mounting screw	9.81 to 11.2 N·m 1.00 to 1.15 kgf·m 7.24 to 8.31 lbf·ft
-------------------	-----------------------------------	---

- (1) Bearing Case Cover Mounting Screw (Inside)
- (2) Bearing Case Cover Mounting Screw (Outside)
- (3) Bearing Case Gasket
- (4) Bearing Case Cover Gasket
- (5) Bearing Case Cover
- (6) Oil Seal

- (a) Top Mark "UP"
- (b) Upside

9Y1210785ENS0053US0

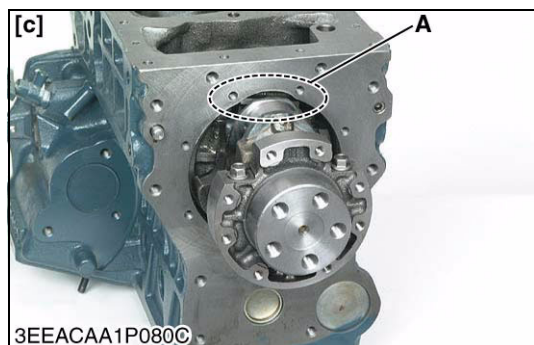
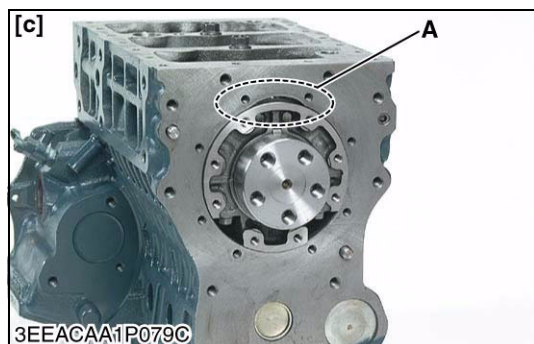
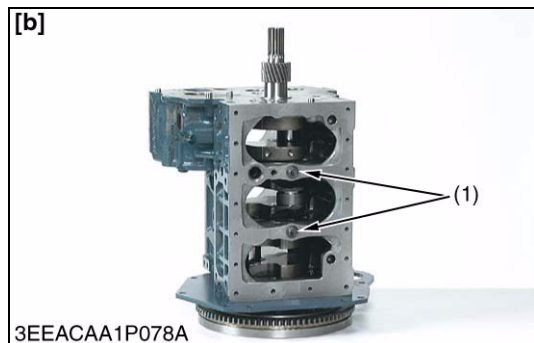
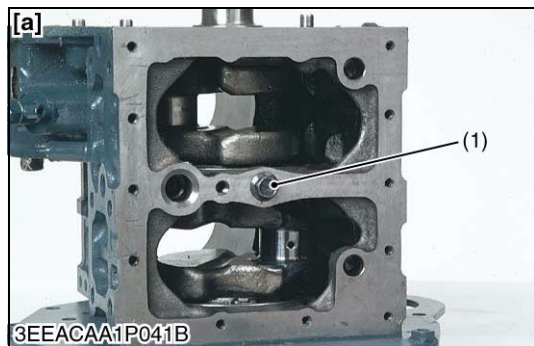

Crankshaft Assembly

For Z482-E4B, D722-E4B

1. Remove the main bearing case screw 2 (1).
2. Draw out all the crankshaft.

For Z602-E4B

1. Remove the main bearing case screw 2 (1).
2. Turn the crankshaft to set the crankpin of the cylinder to the horizontal directions (right or left). Then draw out all the crankshaft, holding the crankpins to the horizontal directions.

For D782-E4B, D902-E4B

1. Remove the main bearing case screw 2 (1).
2. Turn the crankshaft to set the crankpin of the third cylinder to the bottom dead center. Then draw out the crankshaft until the crankpin of the second cylinder comes to the center of the third cylinder.
3. Turn the crankshaft by 2.09 rad (120 °) counterclockwise to set the crankpin of the second cylinder to the bottom dead center. Draw out the crankshaft until the crankpin of the first cylinder comes to the center of the third cylinder.
4. Repeat the above steps to draw out all the crankshaft.

(When reassembling)

- Clean the oil passage of the crankshaft with compressed air.
- Install the crankshaft assembly, aligning the screw hole of main bearing case screw 2 with the screw hole of crankcase.
- When tightening the main bearing case 2, apply oil to the main bearing case screw 2 (1) and screw by hand before tightening the specific torque. If not smooth to screw by hand, align the screw holes between the crankcase and the main bearing case.

Tightening torque	Main bearing case screw 2	27 to 30 N·m
		2.7 to 3.1 kgf·m
		20 to 22 lbf·ft

(1) Main Bearing Case Screw 2

[a] Z482-E4B, Z602-E4B

[b] D722-E4B, D782-E4B, D902-E4B

[c] D782-E4B, D902-E4B

A : Cut place for removing and installing the crankshaft (D782-E4B, D902-E4B)

9Y1210785ENS0054US0

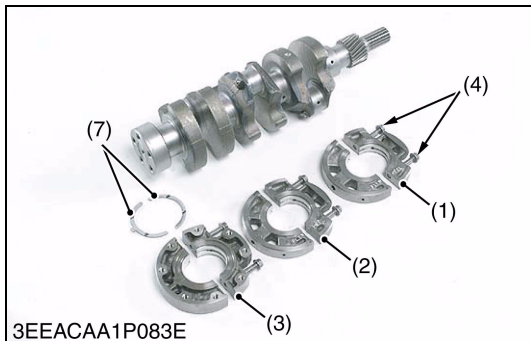
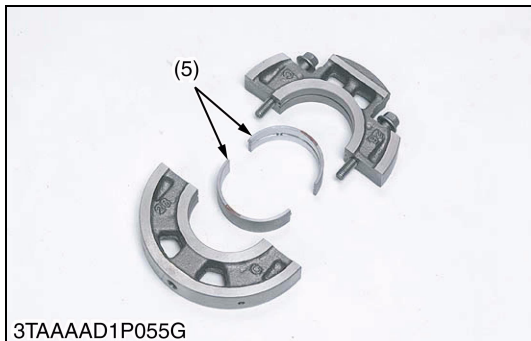
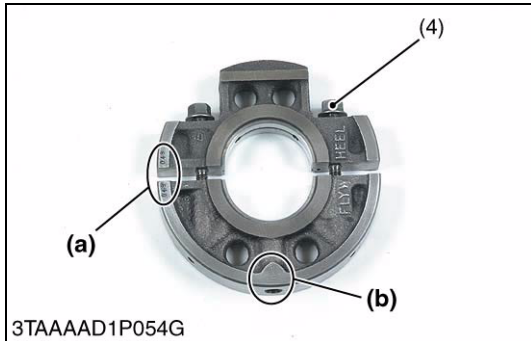
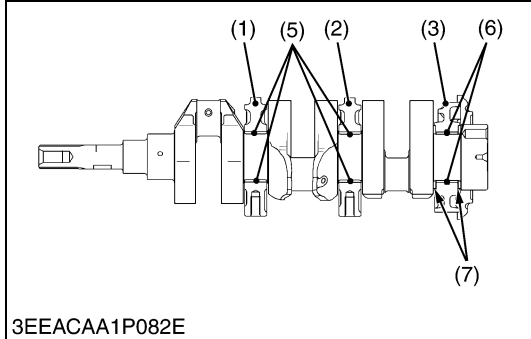
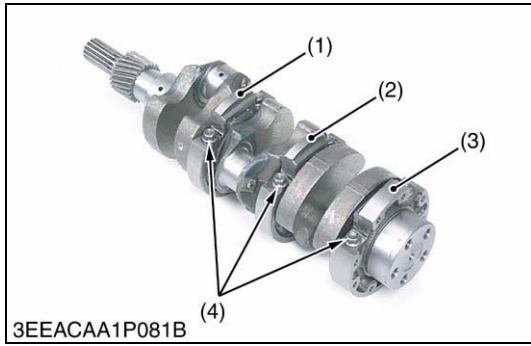

Main Bearing Case Assembly (Z482-E4B, D722-E4B, D782-E4B)

1. Remove the two main bearing case screws 1 (4), and remove the main bearing case assembly 1 (1), being careful with crankshaft bearing 3 (5).
2. Remove the main bearing case assembly 2 (2) and the main bearing case assembly (3) as above. Keep in mind, however, that the thrust bearing (7) is installed in the main bearing case assembly (3).

(When reassembling)

- Clean the oil passage in the main bearing cases.
- Apply clean engine oil to the bearings.
- Install the main bearing case assemblies in original positions. Since diameters of main bearing cases vary, install them in order of marking **(b)** (1 for Z482-E4B and 1, 2 for D722-E4B, D782-E4B) from the gear case side. (Refer to the figure.)
- Match the alignment numbers **(a)** on the main bearing case assembly 1 (1).
- Do the same for the main bearing case assembly 2 (2) and the main bearing case assembly (3) too.
- When installing the main bearing case 1 and 2, face the mark **"FLYWHEEL"** to the flywheel.
- Install the thrust bearing (7) with its oil groove facing outward.
- Confirm that the main bearing case moves smoothly after tightening the main bearing case screw 1 to the specified torque.

Tightening torque	Main bearing case screw 1	13 to 15 N·m 1.3 to 1.6 kgf·m 9.4 to 11 lbf·ft
-------------------	---------------------------	--

- (1) Main Bearing Case Assembly 1 **(a) Alignment Number**
- (2) Main Bearing Case Assembly 2 **(b) Marking (1 or 2)**
- (3) Main Bearing Case Assembly
- (4) Main Bearing Case Screw 1
- (5) Crankshaft Bearing 3
- (6) Crankshaft Bearing 2
- (7) Thrust Bearing

9Y1210785ENS0055US0

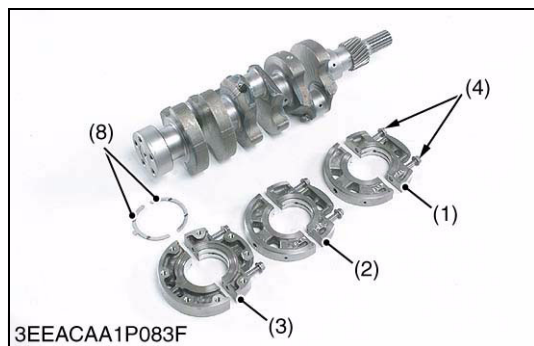
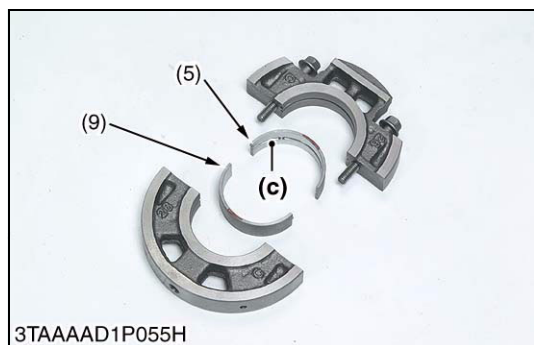
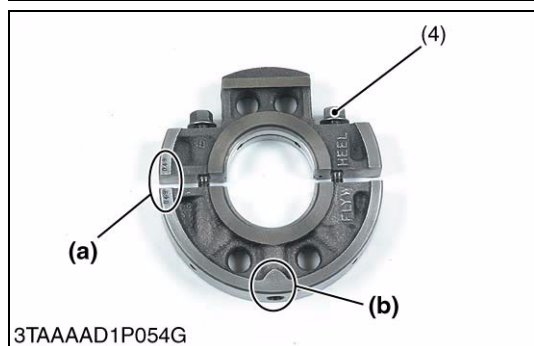
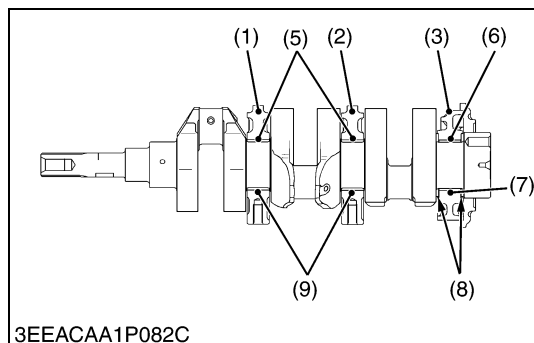
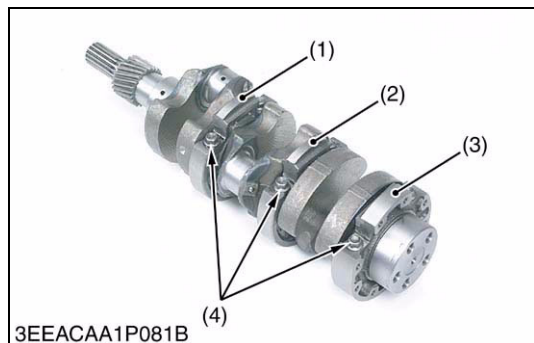

Main Bearing Case Assembly (Z602-E4B, D902-E4B)

1. Remove the two main bearing case screws 1 (4), and remove the main bearing case assembly 1 (1), being careful with crankshaft bearing 3 (5) (9).
2. Remove the main bearing case assembly 2 (2) and the main bearing case assembly (3) as above. Keep in mind, however, that the thrust bearing (8) is installed in the main bearing case assembly (3).

(When reassembling)

- Clean the oil passage in the main bearing cases.
- Apply clean engine oil to the bearings.
- Install the main bearing case assemblies in original positions. Since diameters of main bearing cases vary, install them in order of marking **(b)** (1 for Z602-E4B and 1, 2 for D902-E4B) from the gear case side. (Refer to the figure.)
- Be careful not to confuse the top and bottom of the crankshaft bearing 3 (5) (9). (Install the bearing with the oil groove **(c)** up.)
- Match the alignment numbers **(a)** on the main bearing case assembly 1 (1).
- Do the same for the main bearing case assembly 2 (2) and the main bearing case assembly (3) too.
- When installing the main bearing case 1 and 2, face the mark **"FLYWHEEL"** to the flywheel.
- Install the thrust bearing (8) with its oil groove facing outward.
- Confirm that the main bearing case moves smoothly after tightening the main bearing case screw 1 to the specified torque.

Tightening torque	Main bearing case screw 1	13 to 15 N·m 1.3 to 1.6 kgf·m 9.4 to 11 lbf·ft
-------------------	---------------------------	--

- (1) Main Bearing Case Assembly 1 **(a) Alignment Number**
- (2) Main Bearing Case Assembly 2 **(b) Marking (1 or 2)**
- (3) Main Bearing Case Assembly 3 **(c) Oil Groove**
- (4) Main Bearing Case Screw 1
- (5) Crankshaft Bearing 3
(Upper, with Oil Groove)
- (6) Crankshaft Bearing 2
(Upper, with Oil Groove)
- (7) Crankshaft Bearing 2 (Lower)
- (8) Thrust Bearing
- (9) Crankshaft Bearing 3 (Lower)

9Y1210785ENS0056US0

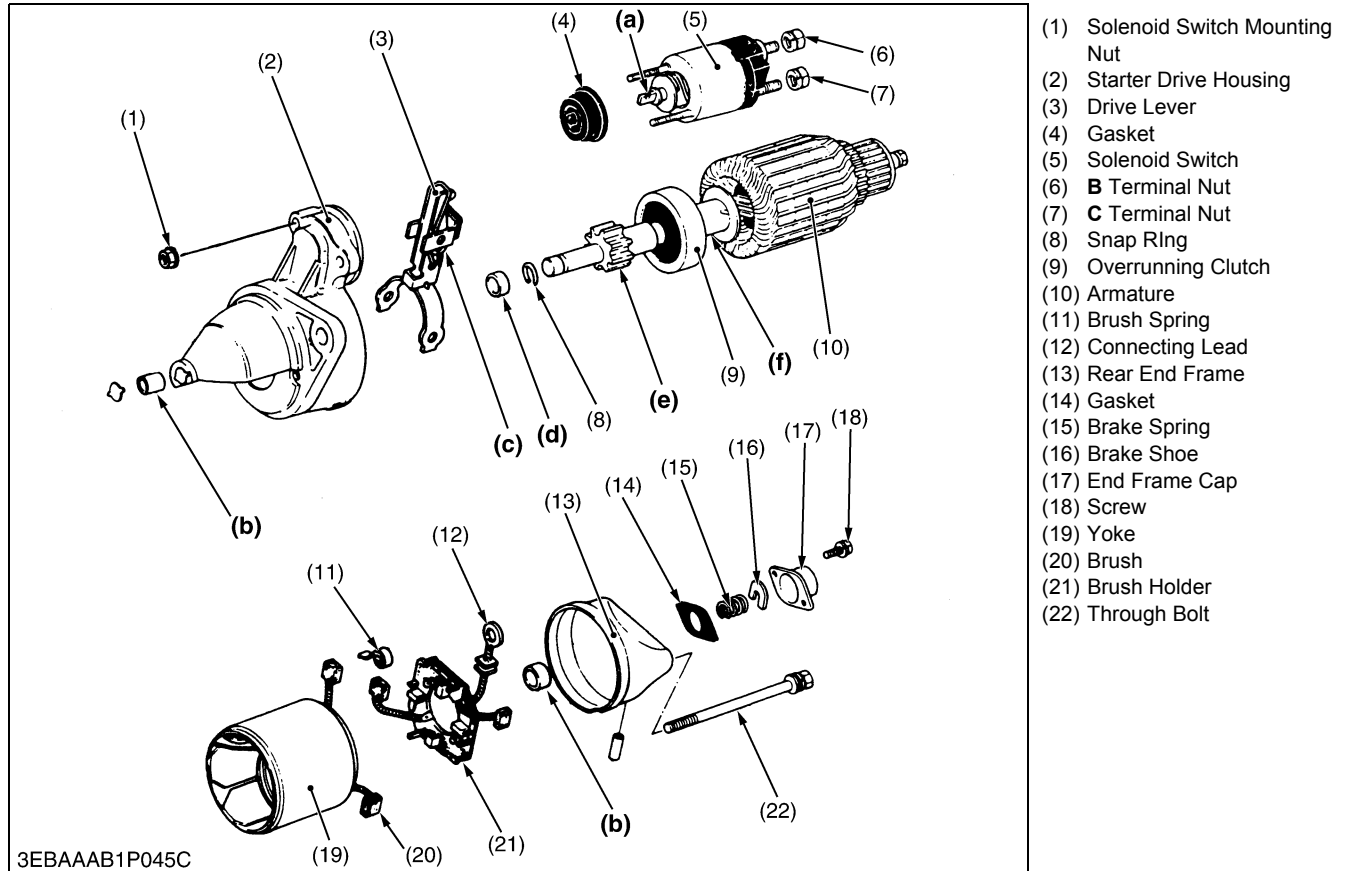
(7) Starter**Electromagnetic Drive Type**

- (1) Solenoid Switch Mounting Nut
- (2) Starter Drive Housing
- (3) Drive Lever
- (4) Gasket
- (5) Solenoid Switch
- (6) **B** Terminal Nut
- (7) **C** Terminal Nut
- (8) Snap Ring
- (9) Overrunning Clutch
- (10) Armature
- (11) Brush Spring
- (12) Connecting Lead
- (13) Rear End Frame
- (14) Gasket
- (15) Brake Spring
- (16) Brake Shoe
- (17) End Frame Cap
- (18) Screw
- (19) Yoke
- (20) Brush
- (21) Brush Holder
- (22) Through Bolt

1. Unscrew the **C** terminal nut (7), and disconnect the connecting lead (12).
2. Unscrew the solenoid switch mounting nuts (1), and remove the solenoid switch (5).
3. Remove the end frame cap (17).
4. Remove the brake shoe (16), brake spring (15) and gasket (14).
5. Unscrew the through bolts (22), and remove the rear end frame (13).
6. Remove the brush from the brush holder while holding the spring up.
7. Remove the brush holder (21).
8. Draw out the yoke (19) from the starter drive housing (2).
9. Draw out the armature (10) with the drive lever (3).

NOTE

- Do not damage to the brush and commutator.

(When reassembling)

- Apply grease (DENSO.CO.LTD. No. 50 or equivalent) to the parts indicated in the figure.
 - Joint of solenoid switch (**a**)
 - Bushing (**b**)
 - Drive lever (**c**)
 - Collar (**d**)
 - Teeth of pinion gear (**e**)
 - Armature shaft (**f**)

Tightening torque	B terminal nut	7.8 to 9.8 N·m 0.80 to 1.0 kgf·m 5.8 to 7.2 lbf·ft
-------------------	-----------------------	--

9Y1210785ENS0057US0

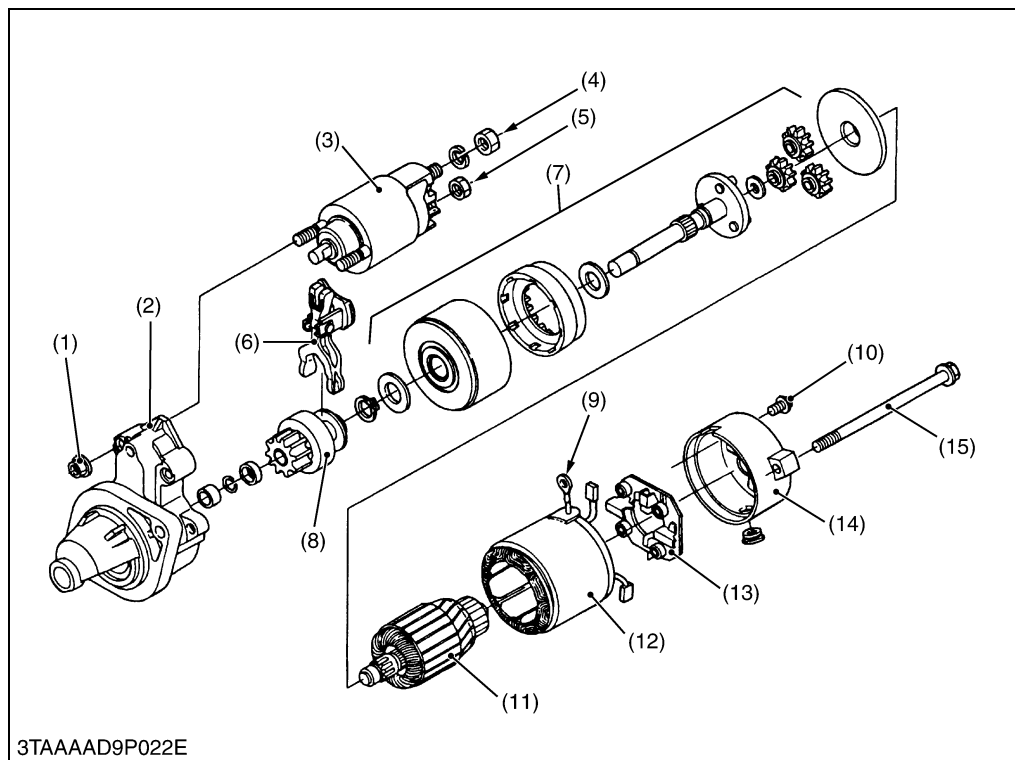
Planetary Gear Reduction Type

- (1) Magnetic Switch Mounting Nut
- (2) Housing
- (3) Magnetic Switch
- (4) **B** Terminal Nut
- (5) **C** Terminal Nut
- (6) Drive Lever
- (7) Shaft Assembly
- (8) Overrunning Clutch
- (9) Connecting Lead
- (10) Mounting Screw
- (11) Armature
- (12) Yoke
- (13) Brush Holder
- (14) Rear End Frame
- (15) Through Bolt

1. Unscrew the **C** terminal nut (5), and disconnect the connecting lead (9).
2. Unscrew the magnetic switch mounting nuts (1), and remove the magnetic switch (3) from the housing (2).
3. Unscrew the through bolts (15) and mounting screw (10), and remove the rear end frame (14).
4. Remove the brush from the brush holder while holding the spring up.
5. Remove the brush holder (13).
6. Draw out the armature (11) and yoke (12) from the housing.
7. Draw out the shaft assembly (7) with the drive lever (6) and overrunning clutch (8) from the housing.

(When reassembling)

Tightening torque	B terminal nut	5.9 to 11 N·m 0.60 to 1.2 kgf·m 4.4 to 8.6 lbf·ft
-------------------	-----------------------	---

9Y1210785ENS0058US0

(8) Dynamo

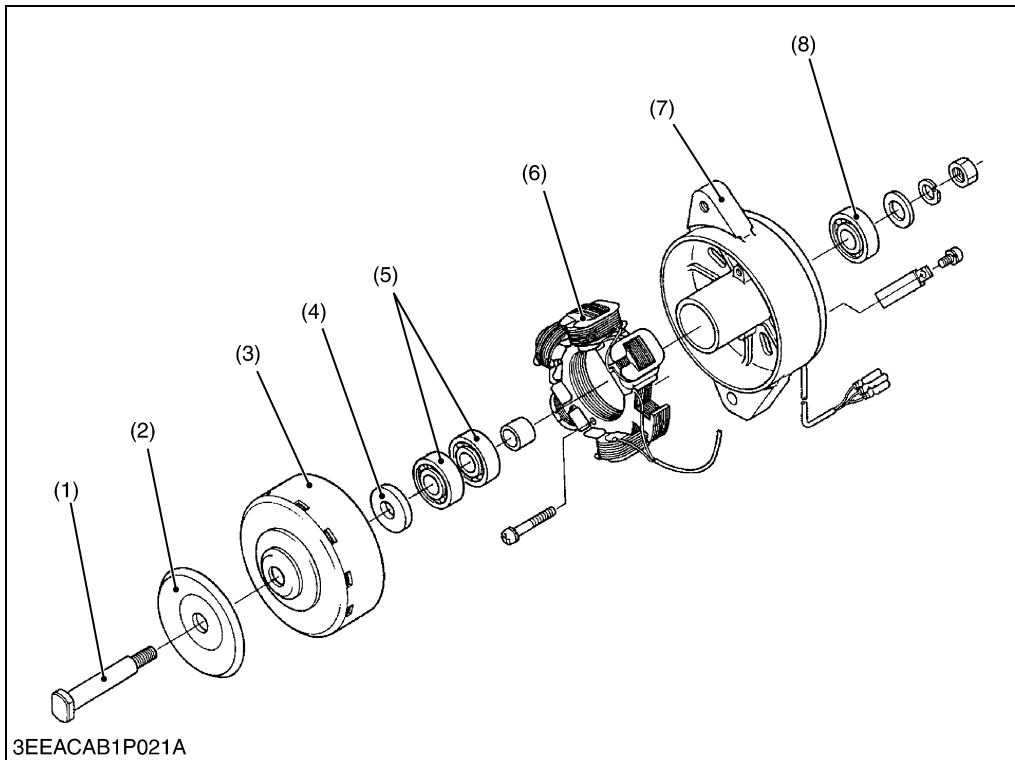

- (1) Shaft
- (2) Pulley
- (3) Rotor
- (4) Collar
- (5) Bearing
- (6) Stator
- (7) Plate
- (8) Bearing

1. Remove the nut and separate the plate (7).
2. Tap out the shaft (1) from the rotor (3).
3. Unscrew the screws and remove the stator (6).

(When reassembling)

- Take care the direction of the collar (4), the flat side should face to the pulley side.

Tightening torque	Pulley nut	40 to 44 N·m 4.0 to 4.5 kgf·m 29 to 32 lbf·ft
-------------------	------------	---

9Y1210785ENS0059US0

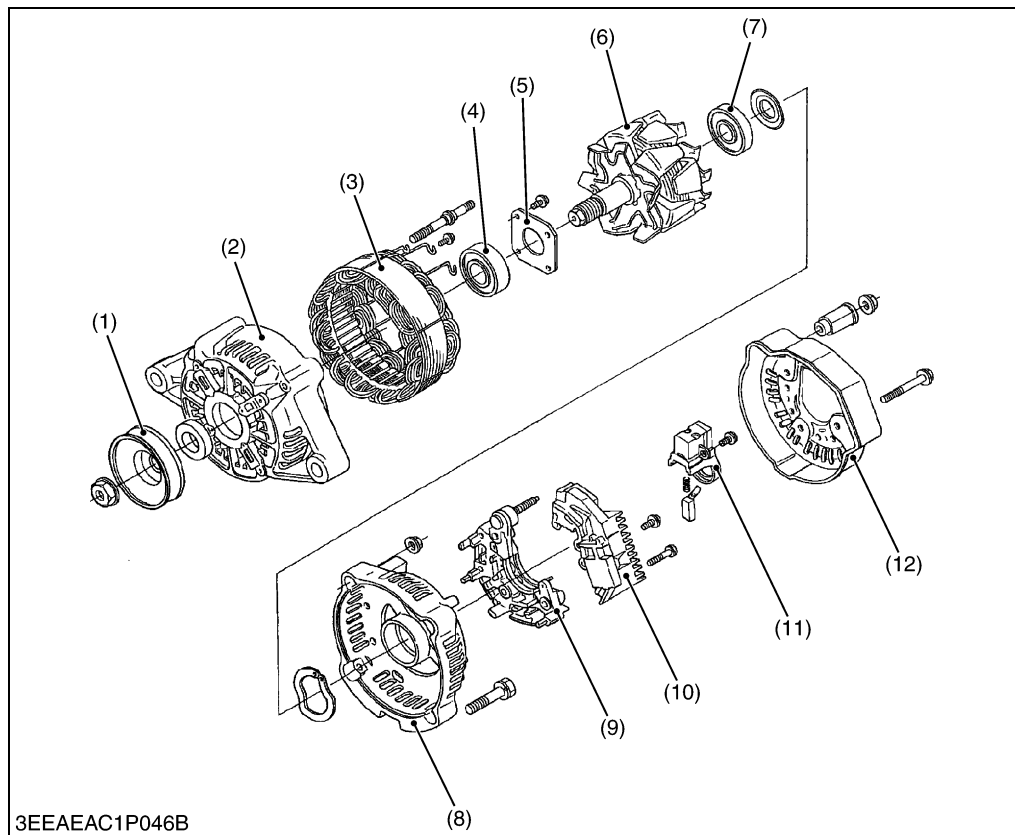
(9) Alternator

- (1) Pulley
- (2) Drive End Frame
- (3) Stator
- (4) Bearing
- (5) Retainer Plate
- (6) Rotor
- (7) Bearing
- (8) Rear End Frame
- (9) Rectifier
- (10) IC Regulator
- (11) Brush Holder
- (12) Rear End Cover

1. Remove the pulley (1).
2. Remove the rear end cover (12).
3. Remove the brush holder (11).
4. Remove the IC regulator (10).
5. Remove the four screws holding the stator lead wires.
6. Remove the rectifier (9).
7. Remove the rear end frame (8).
8. Press out the rotor (6) from drive end frame (2).
9. Remove the retainer plate (5).
10. Press out the bearing (4) from drive end frame (2) with a press and jig.
11. Lightly secure the rotor with a vise to prevent damage, and remove the bearing (7) with a puller.

(When reassembling)

Tightening torque	Pulley nut	58.4 to 78.9 N·m 5.95 to 8.05 kgf·m 43.1 to 58.2 lbf·ft
-------------------	------------	---

9Y1210785ENS0060US0

[3] SERVICING

(1) Cylinder Head and Valves

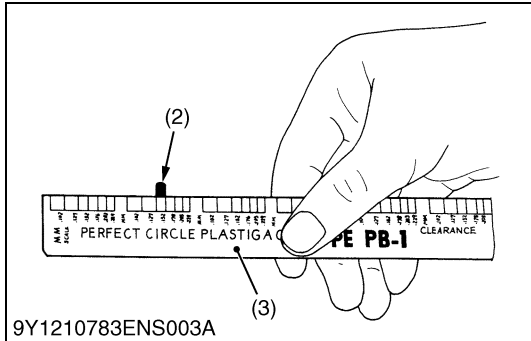
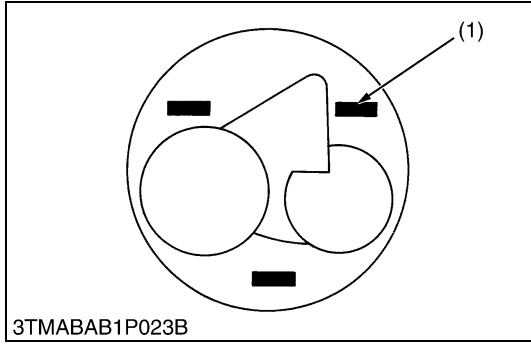

Top Clearance

1. Remove the cylinder head.
2. With the piston at TDC, use grease to affix three or four plastigauges of a diameter 1.5 mm (0.059 in.) x 5.0 to 7.0 mm (0.20 to 0.27 in.) long to the crown of the piston; keep the gauges away from the intake valve and combustion chamber fittings.
3. Take the piston to an intermediate position, install the cylinder head and tighten the head bolts to the specified torque.
4. Turn the crankshaft so the piston goes through TDC.
5. Remove the cylinder head and measure the thickness of the plastigauges.
6. If they are out of spec, check the oil clearance of the crank pin journal and piston pins.

Top clearance	Factory specification	0.50 to 0.70 mm 0.020 to 0.027 in.
---------------	-----------------------	---------------------------------------

Tightening torque	Cylinder head screw	38 to 42 N·m 3.8 to 4.3 kgf·m 28 to 31 lbf·ft
-------------------	---------------------	---

- (1) Plastigauge (3) Scale
(2) Crushed Plastigauge

9Y1210785ENS0061US0



Cylinder Head Surface Flatness

1. Clean the cylinder head surface.
2. Place a straightedge on the cylinder head's four sides and two diagonal as shown in the figure.
3. Measure the clearance with a thickness gauge.
4. If the measurement exceeds the allowable limit, correct it with a surface grinder.

■ IMPORTANT

- Do not place the straightedge on the combustion chamber.
- Be sure to check the valve recessing after correcting.

Cylinder head surface flatness	Allowable limit	0.05 mm 0.002 in.
--------------------------------	-----------------	----------------------

9Y1210785ENS0062US0

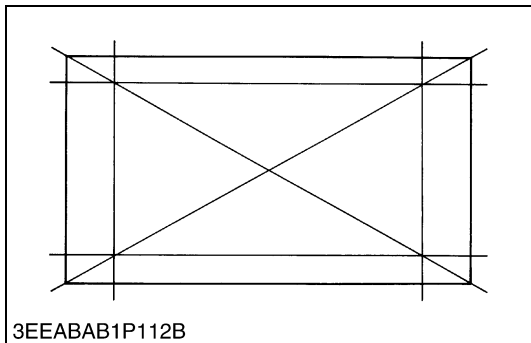

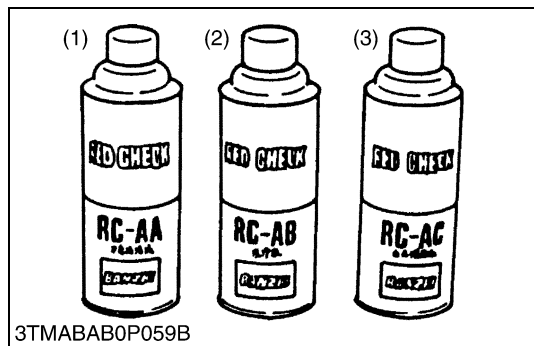

Cylinder Head Flaw

1. Prepare an air spray red check.
2. Clean the surface of the cylinder head with detergent (2).
3. Spray the cylinder head surface with the red permeative liquid (1). Leave it five to ten minutes after spraying.
4. Wash away the red permeative liquid on the cylinder head surface with the detergent (2).
5. Spray the cylinder head surface with white developer (3).
6. If flawed, it can be identified as red marks.

- (1) Red Permeative Liquid (3) White Developer
 (2) Detergent

9Y1210785ENS0063US0



Valve Recessing

1. Clean the cylinder head surface, valve face and valve seat.
2. Insert the valve into the valve guide.
3. Measure the valve recessing with a depth gauge.
4. If the measurement exceeds the allowable limit, replace the valve.
5. If it still exceeds the allowable limit after replacing the valve, replace the cylinder head.

Valve recessing (Intake and exhaust)	Factory specification	-0.10 (protrusion) to 0.10 (recessing) mm -0.0039 (protrusion) to 0.0039 (recessing) in.
	Allowable limit	0.30 (recessing) mm 0.012 (recessing) in.

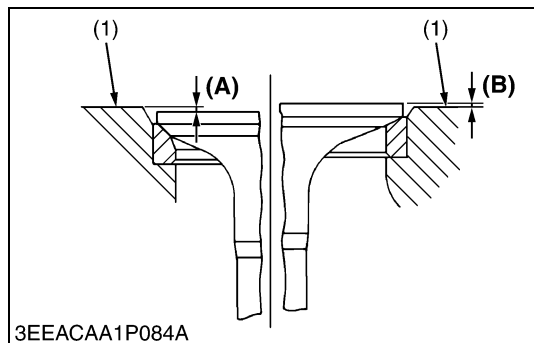

- (1) Cylinder Head Surface (A) Recessing (B) Protrusion

9Y1210785ENS0064US0

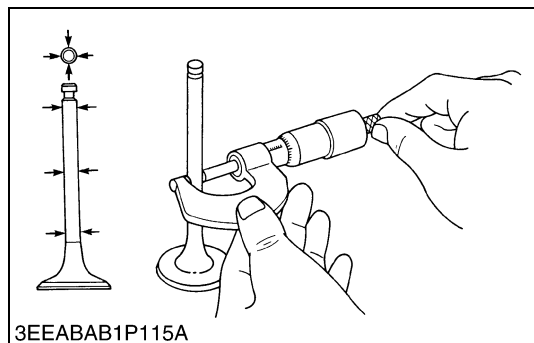

Clearance between Valve Stem and Valve Guide

1. Remove carbon from the valve guide section.
2. Measure the valve stem O.D. with an outside micrometer.
3. Measure the valve guide I.D. with a small hole gauge, and calculate the clearance.
4. If the clearance exceeds the allowable limit, replace the valves. If it still exceeds the allowable limit, replace the valve guide.

Clearance between valve stem and valve guide	Factory specification	0.030 to 0.057 mm 0.0012 to 0.0022 in.
	Allowable limit	0.10 mm 0.0039 in.

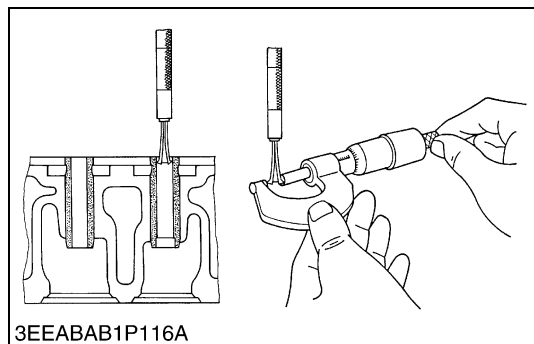

Valve stem O.D.	Factory specification	5.968 to 5.980 mm 0.2350 to 0.2354 in.
Valve guide I.D.	Factory specification	6.010 to 6.025 mm 0.2367 to 0.2372 in.

9Y1210785ENS0065US0

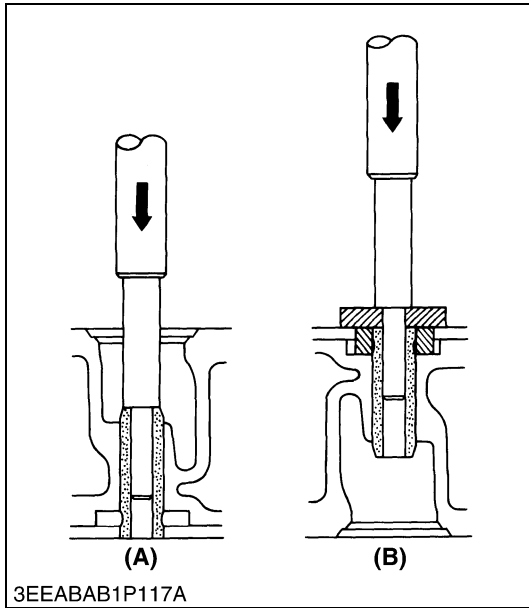

Replacing Valve Guide

(When removing)

1. Press out the used valve guide using a valve guide replacing tool. (Refer to "SPECIAL TOOLS".)

(When installing)

1. Clean a new valve guide and valve guide bore, and apply engine oil to them.
2. Press in a new valve guide using a valve guide replacing tool.
3. Ream precisely the I.D. of the valve guide to the specified dimension.

Valve guide I.D. (Intake and exhaust)	Factory specification	6.010 to 6.025 mm 0.2367 to 0.2372 in.
--	-----------------------	---

■ IMPORTANT

- Do not hit the valve guide with a hammer during replacement.

(A) When Removing

(B) When Installing

9Y1210785ENS0066US0

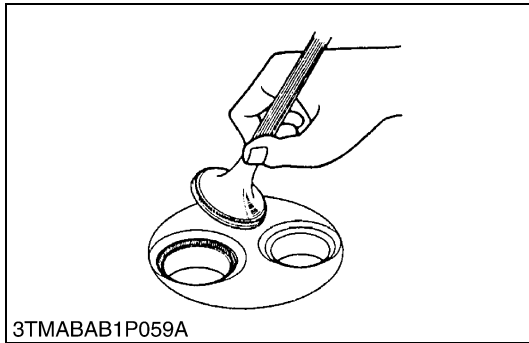

Valve Seating

1. Coat the valve face lightly with prussian blue and put the valve on its seat to check the contact.
2. If the valve does not seat all the way around the valve seat or the valve contact is less than 70 %, correct the valve seating as follows.
3. If the valve contact does not comply with the reference value, replace the valve or correct the contact of valve seating.

Valve seat width	Factory specification	2.12 mm 0.0835 in.
------------------	-----------------------	-----------------------

- (1) Correct
(2) Incorrect

(3) Incorrect

9Y1210785ENS0067US0

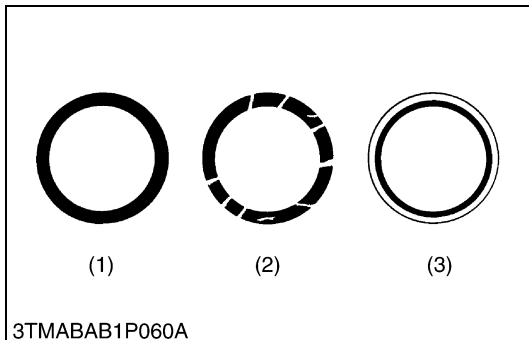

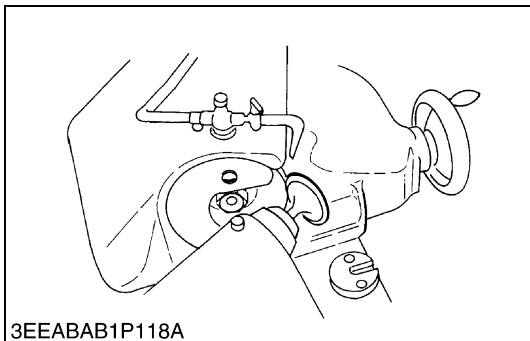

3EEABAB1P118A

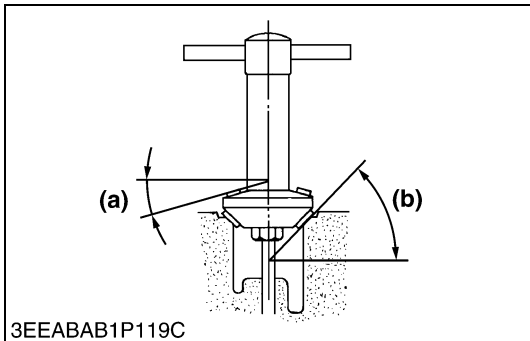

3EEABAB1P119C

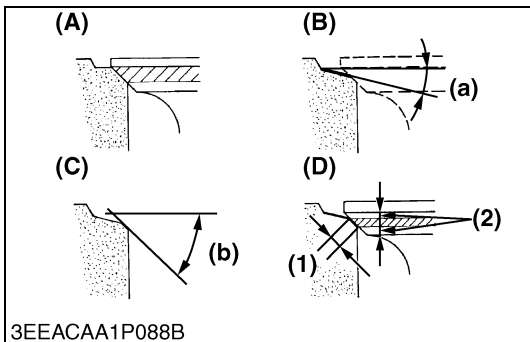

3EEACAA1P088B

Correcting Valve and Valve Seat

■ **NOTE**

- Before correcting the valve and seat, check the valve stem and the I.D. of valve guide section, and repair them if necessary.
- After correcting the valve seat, be sure to check the valve recessing.

1) Correcting Valve

1. Correct the valve with a valve refacer.

Valve face angle	Factory specification	0.79 rad 45 °
------------------	-----------------------	------------------

2) Correcting Valve Seat

1. Slightly correct the seat surface with a 0.79 rad (45 °) valve seat cutter.
2. Fitting the valve, check the contact position of the valve face and seat surface with prussian blue. (Visual check) [If the valve has been used for a long period, the seat tends to come in contact with the upper side of the valve face.]
3. Grind the upper surface of the seat with a 0.26 rad (15 °) valve seat cutter until the valve seat touches to the center of the valve face (so that (1) equals (2) as shown in the figure).
4. Grind the seat with a 0.79 rad (45 °) valve seat cutter again, and visually recheck the contact between the valve and seat.
5. Repeat steps 3 and 4 until the correct contact is achieved.
6. Continue lapping until the seated rate becomes more than 70 % of the total contact area.

Valve seat angle	Factory specification	0.79 rad 45 °
------------------	-----------------------	------------------

- | | |
|--------------------------|------------------------|
| (1) Valve Seat Width | (A) Check Contact |
| (2) Identical Dimensions | (B) Correct Seat Width |
| | (C) Check Seat Surface |
| | (D) Check Contact |
| | (a) 0.26 rad (15 °) |
| | (b) 0.79 rad (45 °) |

9Y1210785ENS0068US0



3EEACAA1P044A

Valve Lapping

1. Apply compound evenly to the valve lapping surface.
2. Insert the valve into the valve guide. Lap the valve onto its seat with a valve flapper or screwdriver.
3. After lapping the valve, wash the compound away and apply oil, then repeat valve lapping with oil.
4. Apply prussian blue to the contact surface to check the seated rate. If it is less than 70 %, repeat valve lapping again.

■ **IMPORTANT**

- When valve lapping is performed, be sure to check the valve recessing and adjust the valve clearance after assembling the valve.

9Y1210785ENS0069US0

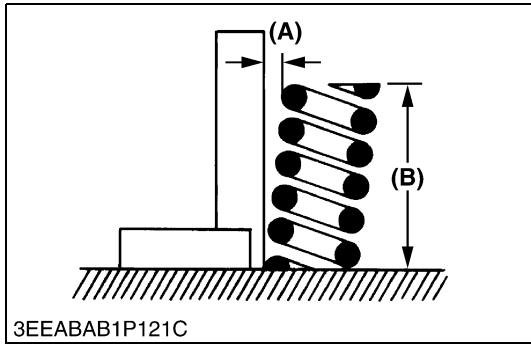

Free Length and Tilt of Valve Spring

1. Measure the free length **(B)** of valve spring with vernier calipers. If the measurement is less than the allowable limit, replace it.
2. Put the valve spring on a surface plate, place a square on the side of the valve spring.
3. Check to see if the entire side is in contact with the square. Rotate the valve spring and measure the maximum tilt **(A)**. If the measurement exceeds the allowable limit, replace it.
4. Check the entire surface of the valve spring for scratches. If there is any defect, replace it.

Tilt (A)	Allowable limit	1.2 mm 0.047 in.
-----------------	-----------------	---------------------

Free length (B)	Factory specification	31.3 to 31.8 mm 1.24 to 1.25 in.
	Allowable limit	28.4 mm 1.12 in.

(A) Tilt

(B) Free length

9Y1210785ENS0070US0

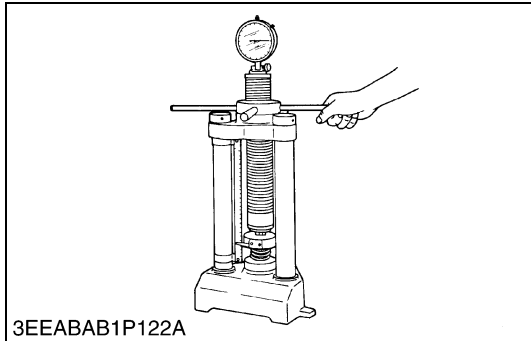

Valve Spring Setting Load

1. Place the valve spring on a tester and compress it to the same length it is actually compressed the engine.
2. Read the compression load on the gauge.
3. If the measurement is less than the allowable limit, replace it.

Setting load / Setting length	Factory specification	65 N / 27.0 mm 6.6 kgf / 27.0 mm 15 lbf / 1.06 in.
	Allowable limit	55 N / 27.0 mm 5.6 kgf / 27.0 mm 12 lbf / 1.06 in.

9Y1210785ENS0071US0



Oil Clearance between Rocker Arm and Rocker Arm Shaft

1. Measure the rocker arm shaft O.D. with an outside micrometer.
2. Measure the rocker arm I.D. with an inside micrometer, and then calculate the oil clearance.
3. If the clearance exceeds the allowable limit, replace the rocker arm and measure the oil clearance again. If it still exceeds the allowable limit, replace also the rocker arm shaft.

Oil clearance between rocker arm and rocker arm shaft	Factory specification	0.016 to 0.045 mm 0.00063 to 0.0017 in.
	Allowable limit	0.15 mm 0.0059 in.

Rocker arm shaft O.D.	Factory specification	10.473 to 10.484 mm 0.41233 to 0.41275 in.
-----------------------	-----------------------	---

Rocker arm I.D.	Factory specification	10.500 to 10.518 mm 0.41339 to 0.41409 in.
-----------------	-----------------------	---

9Y1210785ENS0072US0

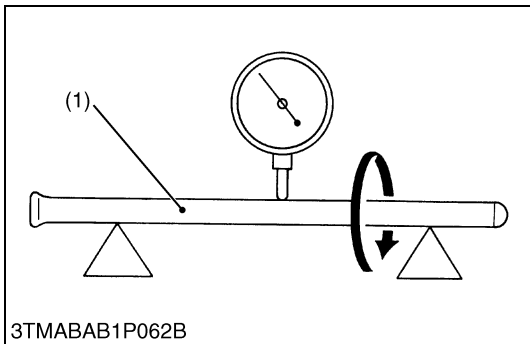

3TMABAB1P062B

Push Rod Alignment

1. Place the push rod on V blocks.
2. Measure the push rod alignment.
3. If the measurement exceeds the allowable limit, replace the push rod.

Push rod alignment	Allowable limit	0.25 mm 0.0098 in.
--------------------	-----------------	-----------------------

(1) Push Rod

9Y1210785ENS0073US0



3TAAAD1P061A

Oil Clearance between Tappet and Tappet Guide Bore

1. Measure the tappet O.D. with an outside micrometer.
2. Measure the I.D. of the tappet guide bore with a cylinder gauge, and calculate the oil clearance.
3. If the oil clearance exceeds the allowable limit or the tappet is damaged, replace the tappet.

Oil clearance between tappet and tappet guide bore	Factory specification	0.016 to 0.052 mm 0.00063 to 0.0020 in.
	Allowable limit	0.10 mm 0.0039 in.



3EEACAA1P045A

Tappet O.D.	Factory specification	17.966 to 17.984 mm 0.70733 to 0.70803 in.
Tappet guide bore I.D.	Factory specification	18.000 to 18.018 mm 0.70867 to 0.70937 in.

9Y1210785ENS0074US0

(2) Timing Gears



3EEACAA1P046A

Timing Gear Backlash

1. Set a dial indicator (lever type) with its tip on the gear tooth.
2. Move the gear to measure the backlash, holding its mating gear.
3. If the backlash exceeds the allowable limit, check the oil clearance of the shaft and the gear.
4. If the oil clearance is proper, replace the gear.

Backlash between idle gear and crank gear	Factory specification	0.0430 to 0.124 mm 0.00170 to 0.00488 in.
	Allowable limit	0.15 mm 0.0059 in.

Backlash between idle gear and cam gear	Factory specification	0.0470 to 0.123 mm 0.00185 to 0.00484 in.
	Allowable limit	0.15 mm 0.0059 in.

Backlash between idle gear and injection pump gear	Factory specification	0.0460 to 0.124 mm 0.00182 to 0.00488 in.
	Allowable limit	0.15 mm 0.0059 in.

Backlash between oil pump drive gear and crank gear	Factory specification	0.0410 to 0.123 mm 0.00162 to 0.00484 in.
	Allowable limit	0.15 mm 0.0059 in.

9Y1210785ENS0075US0

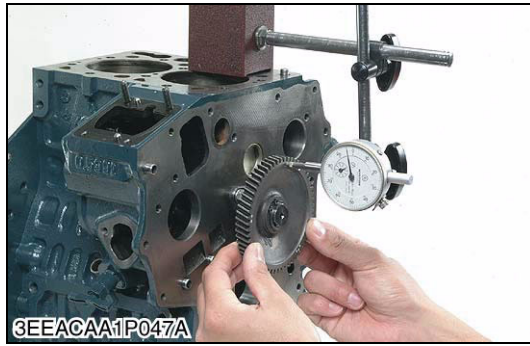

Idle Gear Side Clearance

1. Set a dial indicator with its tip on the idle gear.
2. Measure the side clearance by moving the idle gear to the front and rear.
3. If the measurement exceeds the allowable limit, replace the idle gear collar.

Idle gear side clearance	Factory specification	0.20 to 0.51 mm 0.0079 to 0.020 in.
	Allowable limit	0.80 mm 0.031 in.

9Y1210785ENS0076US0

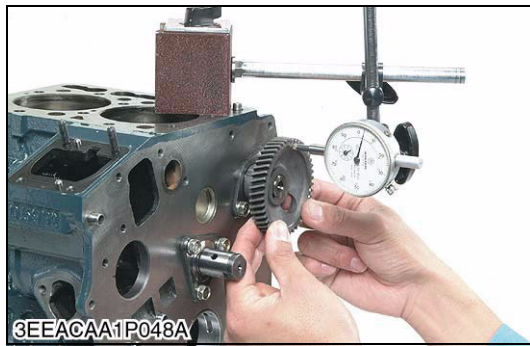

Camshaft Side Clearance

1. Set a dial indicator with its tip on the camshaft.
2. Measure the side clearance by moving the cam gear to the front and rear.
3. If the measurement exceeds the allowable limit, replace the camshaft stopper.

Camshaft side clearance	Factory specification	0.15 to 0.31 mm 0.0059 to 0.012 in.
	Allowable limit	0.50 mm 0.020 in.

9Y1210785ENS0077US0

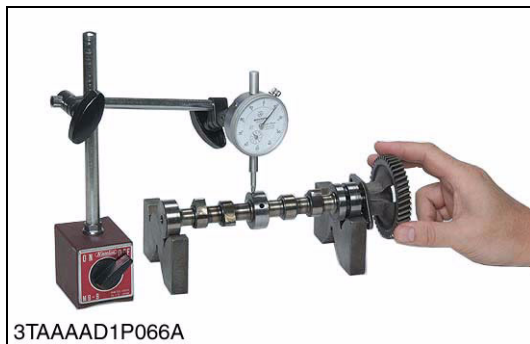

Camshaft Alignment

1. Support the camshaft with V blocks on the surface plate at both end journals.
2. Set a dial indicator with its tip on the intermediate journal.
3. Measure the camshaft alignment.
4. If the measurement exceeds the allowable limit, replace the camshaft.

Camshaft alignment	Allowable limit	0.01 mm 0.0004 in.
--------------------	-----------------	-----------------------

9Y1210785ENS0078US0

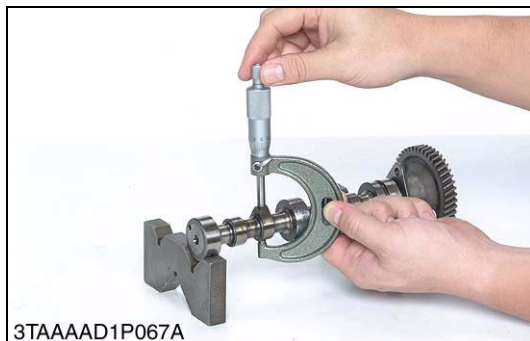

Cam Height

1. Measure the height of the cam at its highest point with an outside micrometer.
2. If the measurement is less than the allowable limit, replace the camshaft.

[Z482-E4B, D722-E4B, D782-E4B]

Cam height	Intake	Factory specification	26.88 mm 1.058 in.
		Allowable limit	26.83 mm 1.056 in.
	Exhaust	Factory specification	25.88 mm 1.019 in.
		Allowable limit	25.83 mm 1.017 in.

[Z602-E4B, D902-E4B]

Cam height	Intake and Exhaust	Factory specification	26.88 mm 1.058 in.
		Allowable limit	26.83 mm 1.056 in.

9Y1210785ENS0079US0



3TAAAD1P069A

Oil Clearance of Camshaft Journal

1. Measure the camshaft journal O.D. with an outside micrometer.
2. Measure the cylinder block bore I.D. for camshaft with a inside micrometer, and calculate the oil clearance.
3. If the oil clearance exceeds the allowable limit, replace the camshaft.

Oil clearance of camshaft journal	Factory specification	0.050 to 0.091 mm 0.0020 to 0.0035 in.
	Allowable limit	0.15 mm 0.0059 in.



3EEACAA1P049A

Camshaft journal O.D.	Factory specification	32.934 to 32.950 mm 1.2967 to 1.2972 in.
Camshaft Bearing I.D. (Cylinder block bore I.D.)	Factory specification	33.000 to 33.025 mm 1.2993 to 1.3001 in.

9Y1210785ENS0080US0



3EEACAA1P050A

Oil Clearance between Idle Gear Shaft and Idle Gear Bushing

1. Measure the idle gear shaft O.D. with an outside micrometer.
2. Measure the idle gear bushing I.D. with an inside micrometer, and calculate the oil clearance.
3. If the oil clearance exceeds the allowable limit, replace the bushing.
4. If it still exceeds the allowable limit, replace the idle gear shaft.

Oil clearance between idle gear shaft and idle gear bushing	Factory specification	0.020 to 0.084 mm 0.00079 to 0.0033 in.
	Allowable limit	0.10 mm 0.0039 in.

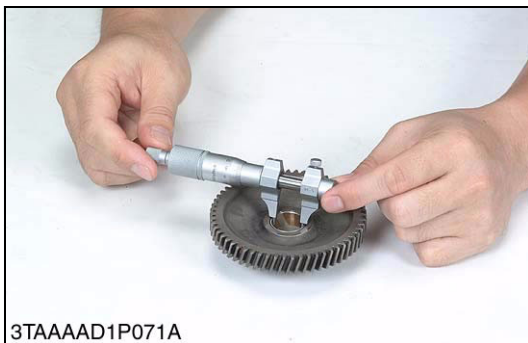

3TAAAD1P071A

Idle gear shaft O.D.	Factory specification	19.967 to 19.980 mm 0.78611 to 0.78661 in.
Idle gear bushing I.D.	Factory specification	20.000 to 20.051 mm 0.78741 to 0.78940 in.

9Y1210785ENS0081US0

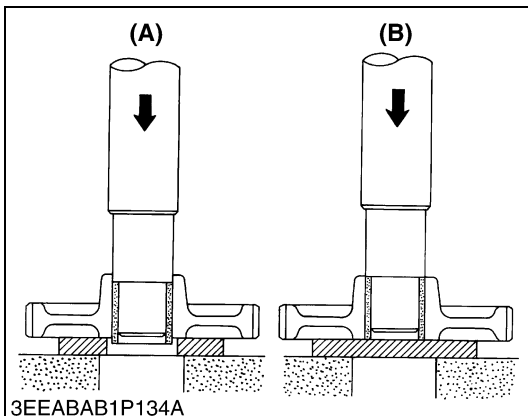

3EEABAB1P134A

Replacing Idle Gear Bushing

(When removing)

1. Press out the used idle gear bushing using an idle gear bushing replacing tool. (Refer to "SPECIAL TOOLS".)

(When installing)

1. Clean a new idle gear bushing and idle gear bore, and apply engine oil to them.
2. Press in a new bushing using an idle gear bushing replacing tool, until it is flush with the end of the idle gear.

(A) When Removing

(B) When Installing

9Y1210785ENS0082US0

(3) Piston and Connecting Rod

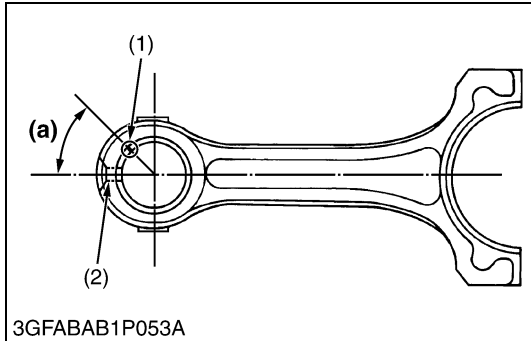
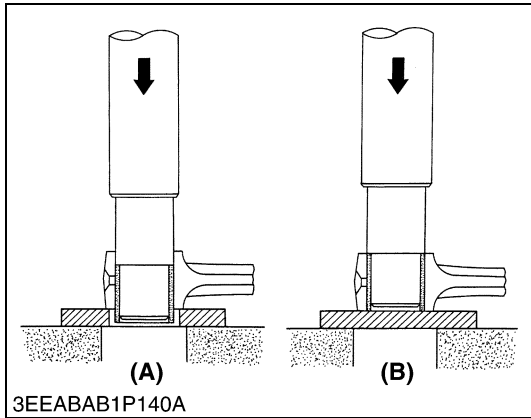
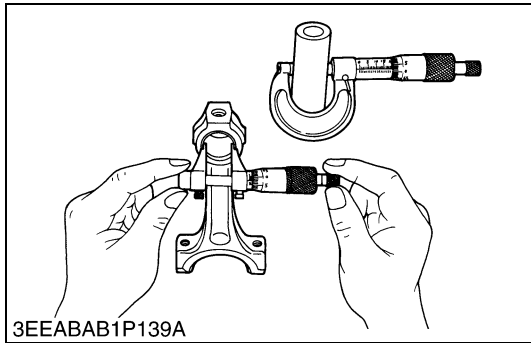
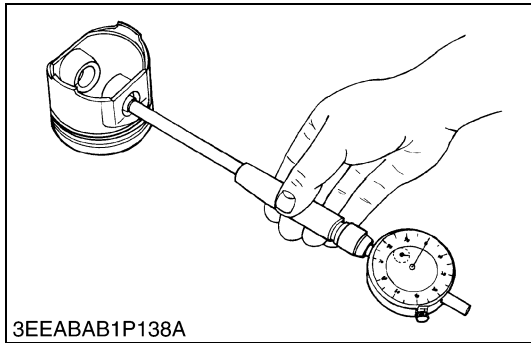

Piston Pin Bore I.D.

1. Measure the piston pin bore I.D. in both the horizontal and vertical directions with a cylinder gauge.
2. If the measurement exceeds the allowable limit, replace the piston.

Piston pin bore I.D.	Factory specification	20.000 to 20.013 mm 0.78741 to 0.78791 in.
	Allowable limit	20.05 mm 0.7894 in.

9Y1210785ENS0083US0

Oil Clearance between Piston Pin and Small End Bushing

1. Measure the piston pin O.D. where it contacts the bushing with an outside micrometer.
2. Measure the small end bushing I.D. with an inside micrometer, and calculate the oil clearance.
3. If the oil clearance exceeds the allowable limit, replace the bushing. If it still exceeds the allowable limit, replace the piston pin.

Oil clearance between piston pin and small end bushing	Factory specification	0.014 to 0.038 mm 0.00056 to 0.0014 in.
	Allowable limit	0.10 mm 0.0039 in.

Piston pin O.D.	Factory specification	20.002 to 20.011 mm 0.78748 to 0.78783 in.
Small end bushing I.D.	Factory specification	20.025 to 20.040 mm 0.78839 to 0.78897 in.

9Y1210785ENS0084US0

Replacing Small End Bushing

(When removing)

1. Press out the used bushing using a small end bushing replacing tool. (Refer to "SPECIAL TOOLS").

(When installing)

1. Clean a new small end bushing and small end hole, and apply engine oil to them.
2. Using a small end bushing replacing tool, press in a new bushing (service parts) taking due care to see that the position of the connecting rod oil hole matches the bushing hole.

[Servicing parts dimension]

Oil clearance between piston pin and small end bushing (Spare parts)	Factory specification	0.015 to 0.075 mm 0.00059 to 0.0029 in.
	Allowable limit	0.15 mm 0.0059 in.

Small end bushing I.D. (Spare parts)	Factory specification	20.026 to 20.077 mm 0.78843 to 0.79043 in.
--------------------------------------	-----------------------	---

- (1) Seam
- (2) Oil Hole

- (A) When Removing**
- (B) When Installing**
- (C) 0.79 rad (45 °)**

9Y1210785ENS0085US0

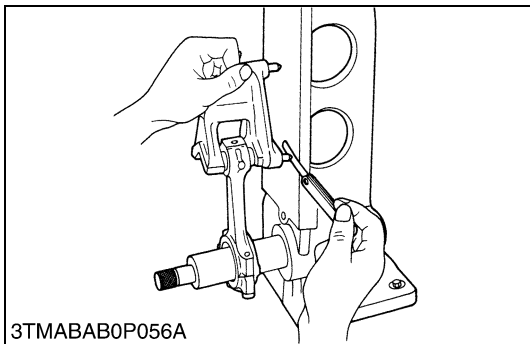

Connecting Rod Alignment

■ **NOTE**

- Since the I.D. of the connecting rod small end bushing is the basis of this check, check bushing for wear beforehand.

1. Install the piston pin into the connecting rod.
2. Install the connecting rod on the connecting rod alignment tool.
3. Put a gauge over the piston pin, and move it against the face plate.
4. If the gauge does not fit squarely against the face plate, measure the space between the pin of the gauge and the face plate.
5. If the measurement exceeds the allowable limit, replace the connecting rod.

Connecting rod alignment	Allowable limit	0.05 mm 0.002 in.
--------------------------	-----------------	----------------------

9Y1210785ENS0086US0

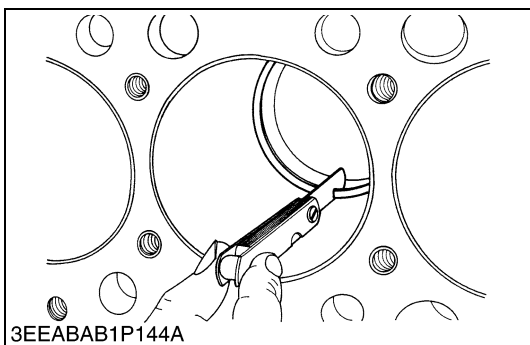

Piston Ring Gap

1. Insert the piston ring into the lower part of the cylinder (the least worn out part) with a piston ring compressor and piston.
2. Measure the ring gap with a feeler gauge.
3. If the measurement exceeds the allowable limit, replace the piston ring.

Piston ring gap [Z482-E4B] [D722-E4B] [D782-E4B]	Top ring	Factory specification	0.12 to 0.27 mm 0.0047 to 0.010 in.
		Allowable limit	1.15 mm 0.0453 in.
	Second ring	Factory specification	0.30 to 0.45 mm 0.012 to 0.017 in.
		Allowable limit	1.20 mm 0.0472 in.
	Oil ring	Factory specification	0.15 to 0.35 mm 0.0059 to 0.013 in.
		Allowable limit	1.20 mm 0.0472 in.
Piston ring gap [Z602-E4B] [D902-E4B]	Top ring	Factory specification	0.15 to 0.30 mm 0.0059 to 0.011 in.
		Allowable limit	1.25 mm 0.0472 in.
	Second ring	Factory specification	0.35 to 0.50 mm 0.014 to 0.019 in.
		Allowable limit	1.25 mm 0.0492 in.
	Oil ring	Factory specification	0.15 to 0.35 mm 0.0059 to 0.013 in.
		Allowable limit	1.20 mm 0.0472 in.

9Y1210785ENS0087US0

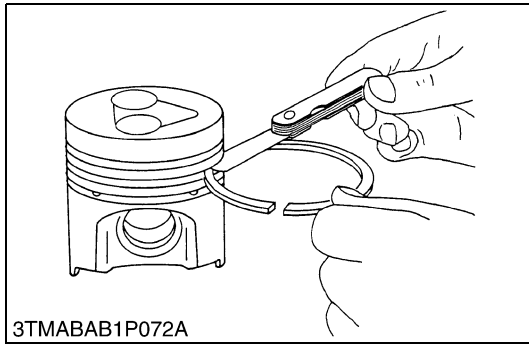

3TMABAB1P072A

Clearance between Piston Ring and Piston Ring Groove

1. Clean the rings and the ring grooves, and install each ring in its groove.
2. Measure the clearance between the ring and the groove with a feeler gauge.
3. If the clearance exceeds the allowable limit, replace the piston ring.
4. If the clearance still exceeds the allowable limit after replacing the ring, replace the piston.

Clearance between piston ring and piston ring groove	Second ring	Factory specification	0.0900 to 0.120 mm 0.00355 to 0.00472 in.
		Allowable limit	0.15 mm 0.0059 in.
	Oil ring	Factory specification	0.040 to 0.080 mm 0.0016 to 0.0031 in.
		Allowable limit	0.15 mm 0.0059 in.

9Y1210785ENS0088US0

(4) Crankshaft

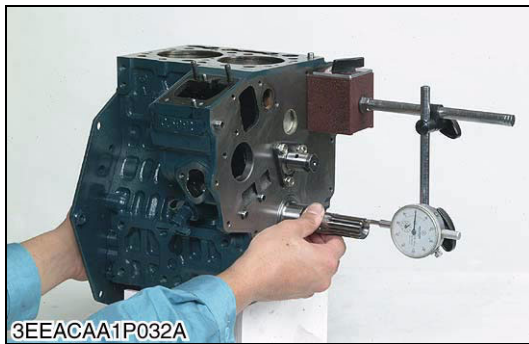

3EEACAA1P032A

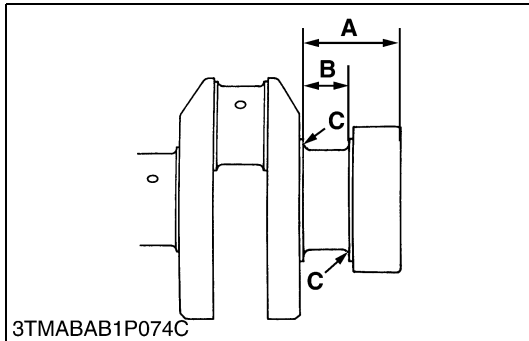

3TMABAB1P074C

Crankshaft Side Clearance

1. Set a dial indicator with its tip on the end of the crankshaft.
2. Measure the side clearance by moving the crankshaft to the front and rear.
3. If the measurement exceeds the allowable limit, replace the thrust bearings.
4. If the same size bearing is useless because of the crankshaft journal wear, replace it with an oversize one referring to the table and figure.

Crankshaft side clearance	Factory specification	0.15 to 0.31 mm 0.0059 to 0.012 in.
	Allowable limit	0.50 mm 0.020 in.

(Reference)

- Oversize thrust bearing

Oversize	Bearing	Code Number	Marking
0.20 mm 0.0079 in.	Thrust bearing 1 02	15261-23950	020 OS
	Thrust bearing 2 02	15261-23970	020 OS
0.40 mm 0.016 in.	Thrust bearing 1 04	15261-23960	040 OS
	Thrust bearing 2 04	15261-23980	040 OS

- Oversize dimensions of crankshaft journal

Oversize	0.20 mm 0.0079 in.	0.40 mm 0.016 in.
Dimension A	46.10 to 46.30 mm 1.815 to 1.822 in.	46.30 to 46.50 mm 1.823 to 1.830 in.
Dimension B	23.40 to 23.45 mm 0.9213 to 0.9232 in.	23.80 to 23.85 mm 0.9370 to 0.9389 in.
Dimension C	1.8 to 2.2 mm radius 0.071 to 0.086 in. radius	1.8 to 2.2 mm radius 0.071 to 0.086 in. radius

The crankshaft journal must be fine-finished to higher than Rmax. = 0.8S

9Y1210785ENS0089US0

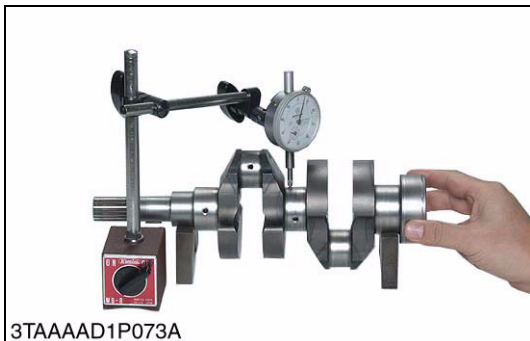

Crankshaft Alignment

1. Support the crankshaft with V blocks on the surface plate at both end journals.
2. Set a dial indicator with its tip on the intermediate journal.
3. Measure the crankshaft alignment.
4. If the measurement exceeds the allowable limit, replace the crankshaft.

Crankshaft alignment	Allowable limit	0.02 mm 0.0008 in.
----------------------	-----------------	-----------------------

9Y1210785ENS0090US0

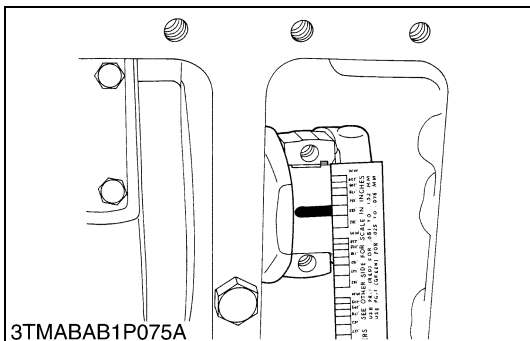

Oil Clearance between Crankpin and Crankpin Bearing

1. Clean the crankpin and crankpin bearing.
2. Put a strip of plastigage on the center of the crankpin.
3. Install the connecting rod cap and tighten the connecting rod screws to the specified torque, and remove the cap again.
4. Measure the amount of the flattening with the scale, and get the oil clearance.
5. If the oil clearance exceeds the allowable limit, replace the crankpin bearing.
6. If the same size bearing is useless because of the crankpin wear, replace it with an undersize one referring to the table and figure.

■ **NOTE**

- Never insert the plastigage into the crankpin oil hole.
- Be sure not to move the crankshaft while the connecting rod screws are tightened.

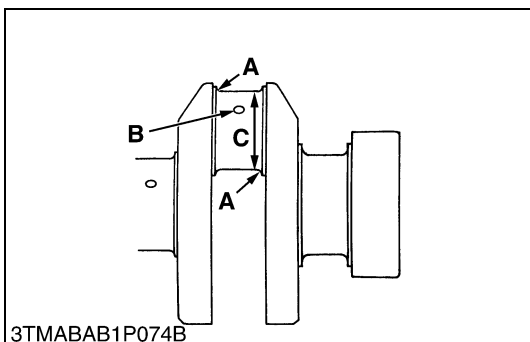

Oil clearance between crankpin and crankpin bearing	Factory specification	0.020 to 0.051 mm 0.00079 to 0.0020 in.
	Allowable limit	0.15 mm 0.0059 in.

Crankpin O.D.	Factory specification	33.959 to 33.975 mm 1.3370 to 1.3375 in.
Crankpin bearing I.D.	Factory specification	33.995 to 34.010 mm 1.3384 to 1.3389 in.

(Reference)

- Undersize crankpin bearing

Undersize	Bearing	Code Number	Marking
0.20 mm 0.0079 in.	Crankpin bearing 02	15861-22970	020 US
0.40 mm 0.016 in.	Crankpin bearing 04	15861-22980	040 US

- Undersize dimensions of crankpin

Undersize	0.20 mm 0.0079 in.	0.40 mm 0.016 in.
Dimension A	2.3 to 2.7 mm radius 0.091 to 0.10 in.radius	2.3 to 2.7 mm radius 0.091 to 0.10 in.radius
*Dimension B	1.0 to 1.5 mm relief 0.040 to 0.059 in. relief	1.0 to 1.5 mm relief 0.040 to 0.059 in. relief
Dimension C	33.759 to 33.775 mm dia. 1.3291 to 1.3297 in. dia.	33.559 to 33.575 mm dia. 1.3213 to 1.3218 in. dia.

The crankpin must be fine-finished to higher than Rmax. = 0.8S
 *Holes to be de-burred and edges rounded with 1.0 to 1.5 mm (0.040 to 0.059 in.) relief.

9Y1210785ENS0091US0

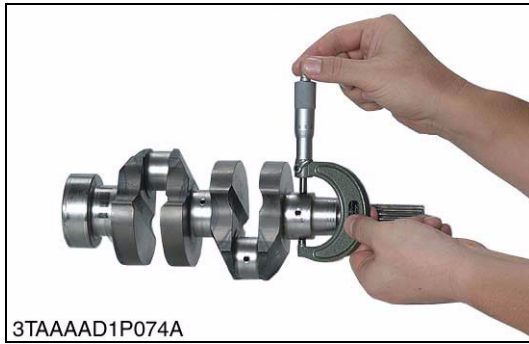

3TAAAD1P074A



3EEACAA1P012A

Oil Clearance between Crankshaft Journal and Crankshaft Bearing 1

1. Measure the O.D. of the crankshaft front journal with an outside micrometer.
2. Measure the I.D. of the crankshaft bearing 1 with an inside micrometer, and calculate the oil clearance.
3. If the oil clearance exceeds the allowable limit, replace the crankshaft bearing 1.
4. If the same size bearing is useless because of the crankshaft journal wear, replace it with an undersize one referring to the table and the figure.

Oil Clearance between crankshaft journal and crankshaft bearing 1	Factory specification	0.0340 to 0.106 mm 0.00134 to 0.00417 in.
	Allowable limit	0.20 mm 0.0079 in.

Crankshaft journal O.D.	Factory specification	Z482-E4B D722-E4B D782-E4B	39.934 to 39.950 mm 1.5722 to 1.5728 in.
		Z602-E4B D902-E4B	43.934 to 43.950 mm 1.7297 to 1.7303 in.
Crankshaft bearing 1 I.D.	Factory specification	Z482-E4B D722-E4B D782-E4B	39.984 to 40.040 mm 1.5742 to 1.5763 in.
		Z602-E4B D902-E4B	43.984 to 44.040 mm 1.7317 to 1.7338 in.

(To be continued)

(Continued)

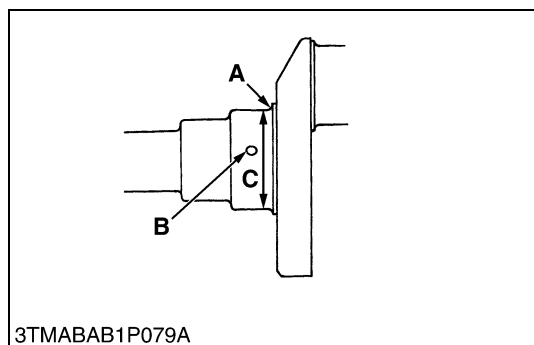

(Reference)

- Undersize crankshaft bearing 1

Undersize	Models	Bearing	Code Number	Marking
0.20 mm 0.0079 in.	Z482-E4B D722-E4B D782-E4B	Crankshaft bearing 1 02	15861-23910	020 US
	Z602-E4B D902-E4B		1G460-23910	
0.40 mm 0.016 in.	Z482-E4B D722-E4B D782-E4B	Crankshaft bearing 1 04	15861-23920	040 US
	Z602-E4B D902-E4B		1G460-23920	

- Undersize dimensions of crankshaft journal

Undersize	Models	0.20 mm 0.0079 in.	0.40 mm 0.016 in.
Dimension A	All models	1.8 to 2.2 mm radius 0.071 to 0.086 in. radius	1.8 to 2.2 mm radius 0.071 to 0.086 in. radius
*Dimension B	All models	1.0 to 1.5 mm relief 0.040 to 0.059 in. relief	1.0 to 1.5 mm relief 0.040 to 0.059 in. relief
Dimension C	Z482-E4B D722-E4B D782-E4B	39.734 to 39.750 mm dia. 1.5644 to 1.5649 in. dia.	39.534 to 39.550 mm dia. 1.5565 to 1.5570 in. dia.
	Z602-E4B D902-E4B	43.734 to 43.750 mm dia. 1.7219 to 1.7224 in. dia.	43.534 to 43.550 mm dia. 1.7140 to 1.7145 in. dia.

The crankshaft journal must be fine-finished to higher than Rmax. = 0.8S
 *Holes to be de-burred and edges rounded with 1.0 to 1.5 mm (0.040 to 0.059 in.) relief.

9Y1210785ENS0092US0

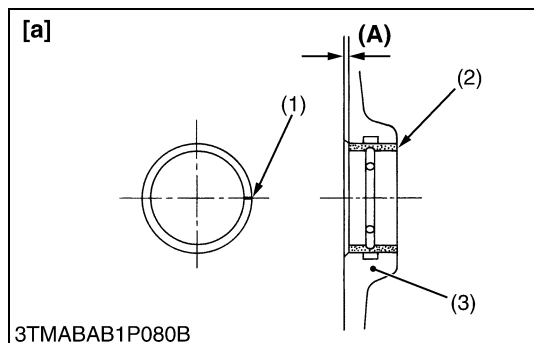

3TMABAB1P080B

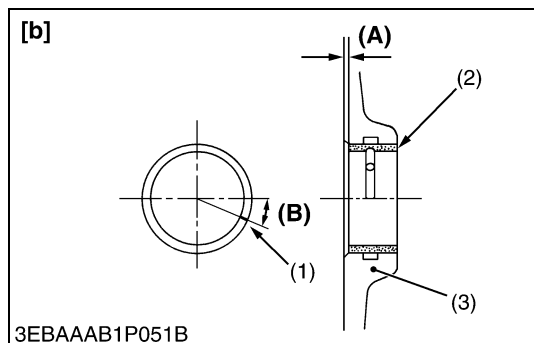

3EBAAAB1P051B

Replacing Crankshaft Bearing 1

(When removing)

1. Press out the used crankshaft bearing 1 using a crankshaft bearing 1 replacing tool. (Refer to "SPECIAL TOOLS".)

(When installing)

1. Clean a new crankshaft bearing 1 and crankshaft journal bore, and apply engine oil to them.
2. Using a crankshaft bearing 1 replacing tool, press in a new bearing 1 (2) so that its seam (1) directs toward the exhaust manifold side. (See figure.)

Dimension (A)	Factory specification	0 to 0.3 mm 0 to 0.01 in.
---------------	-----------------------	------------------------------

- (1) Seam
- (2) Crankshaft Bearing 1
- (3) Cylinder Block

- (A) Dimension
- (B) 0.37 rad (21 °)
- [a] Z482-E4B, D722-E4B, D782-E4B
- [b] Z602-E4B, D902-E4B

9Y1210785ENS0093US0

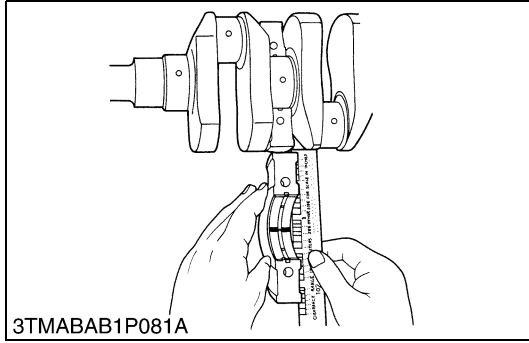

Oil Clearance between Crankshaft Journal and Crankshaft Bearing 2 and Crankshaft Bearing 3

1. Put a strip of plastigage on the center of the journal.
2. Install the bearing case and tighten the bearing case screws 1 to the specified torque, and remove the bearing case again.
3. Measure the amount of the flattening with the scale, and get the oil clearance.
4. If the oil clearance exceeds the allowable limit, replace the crankshaft bearing 2 (crankshaft bearing 3).
5. If the same size bearing is useless because of the crankshaft journal wear, replace it with an undersize one referring to the table and figure.

■ NOTE

- **Be sure not to move the crankshaft while the bearing case screws are tightened.**

Oil clearance between crankshaft journal and crankshaft bearing 2 (crankshaft bearing 3)	Factory specification	0.028 to 0.059 mm 0.0011 to 0.0023 in.
	Allowable limit	0.20 mm 0.0079 in.

Crankshaft journal O.D. (Flywheel side)	Factory specification	43.934 to 43.950 mm 1.7297 to 1.7303 in.
---	-----------------------	---

Crankshaft bearing 2 I.D.	Factory specification	43.978 to 43.993 mm 1.7315 to 1.7320 in.
---------------------------	-----------------------	---

Crankshaft journal O.D. (Intermediate)	Factory specification	Z482-E4B D722-E4B D782-E4B	39.934 to 39.950 mm 1.5722 to 1.5728 in.
		Z602-E4B D902-E4B	43.934 to 43.950 mm 1.7297 to 1.7303 in.
Crankshaft bearing 3 I.D.	Factory specification	Z482-E4B D722-E4B D782-E4B	39.978 to 39.993 mm 1.5740 to 1.5745 in.
		Z602-E4B D902-E4B	43.978 to 43.993 mm 1.7315 to 1.7320 in.

(To be continued)

(Continued)

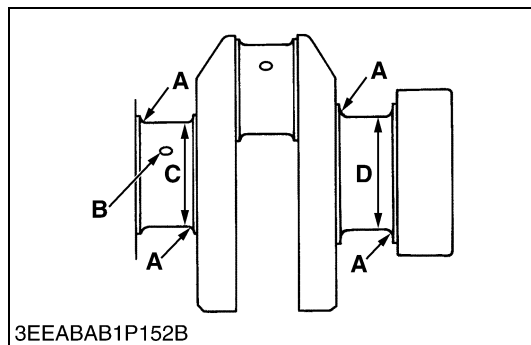

3EEABAB1P152B

(Reference)

- Undersize crankshaft bearing 2 and 3

Undersize	Models	Bearing	Code Number	Marking
0.20 mm 0.0079 in.	Z482-E4B D722-E4B D782-E4B	Crankshaft bearing 2 02	15694-23930	020 US
		Crankshaft bearing 3 02	15861-23860	
	Z602-E4B D902-E4B	Crankshaft bearing 2 02	1G460-23930	
		Crankshaft bearing 3 02	1G460-23940	

- Undersize crankshaft bearing 2 and 3

Undersize	Models	Bearing	Code Number	Marking
0.40 mm 0.016 in.	Z482-E4B D722-E4B D782-E4B	Crankshaft bearing 2 04	15694-23940	040 US
		Crankshaft bearing 3 04	15861-23870	
	Z602-E4B D902-E4B	Crankshaft bearing 2 04	1G460-23950	
		Crankshaft bearing 3 04	1G460-23960	

- Undersize dimensions of crankshaft journal

Undersize	Models	0.20 mm 0.0079 in.	0.40 mm 0.016 in.
Dimension A	All models	1.8 to 2.2 mm radius 0.071 to 0.086 in. radius	1.8 to 2.2 mm radius 0.071 to 0.086 in. radius
*Dimension B	All models	1.0 to 1.5 mm relief 0.040 to 0.059 in. relief	1.0 to 1.5 mm relief 0.040 to 0.059 in. relief
Dimension C	Z482-E4B D722-E4B D782-E4B	39.734 to 39.750 mm dia. 1.5644 to 1.5649 in. dia.	39.534 to 39.550 mm dia. 1.5565 to 1.5570 in. dia.
	Z602-E4B D902-E4B	43.734 to 43.750 mm dia. 1.7219 to 1.7224 in. dia.	43.534 to 43.550 mm dia. 1.7140 to 1.7145 in. dia.
Dimension D	All models	43.734 to 43.750 mm dia. 1.7219 to 1.7224 in. dia.	43.534 to 43.550 mm dia. 1.7140 to 1.7145 in. dia.
The crankshaft journal must be fine-finished to higher than Rmax. = 0.8S *Holes to be de-burred and edges rounded with 1.0 to 1.5 mm (0.040 to 0.059 in.) relief.			

9Y1210785ENS0094US0

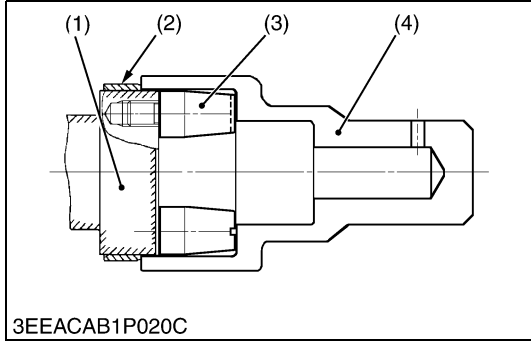
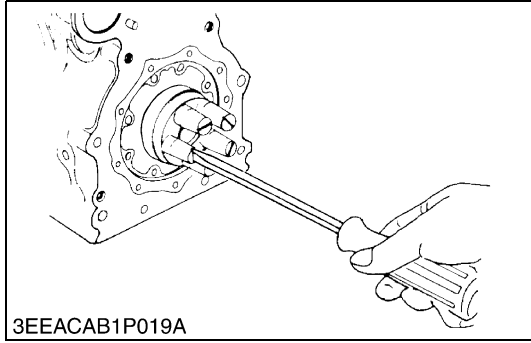

Replacing Crankshaft Sleeve (Z482-E4B, D722-E4B, D782-E4B)

1. Remove the used crankshaft sleeve (2).
2. Set the sleeve guide (3) to the crankshaft (1).
3. Heat a new sleeve to a temperature between 150 and 200 °C (302 and 392 °F), and fix the sleeve to the crankshaft as shown in figure.
4. Press fit the sleeve using the auxiliary socket for pushing (4). (Refer to "SPECIAL TOOLS".)

NOTE

- Mount the sleeve with its largely chamfered surface facing outward.
- Should heating is not enough, a sleeve might stop halfway, so careful.

- | | |
|-----------------------|----------------------------------|
| (1) Crankshaft | (3) Sleeve Guide |
| (2) Crankshaft Sleeve | (4) Auxiliary Socket for Pushing |

9Y1210785ENS0095US0

(5) Cylinder

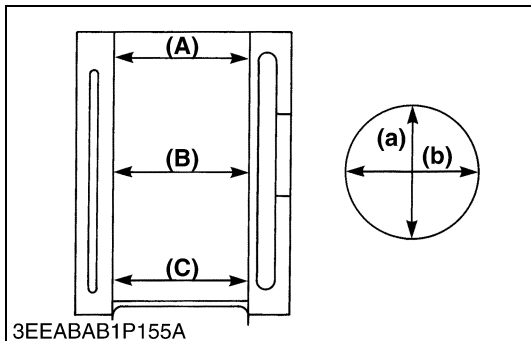

Cylinder Wear

1. Measure the cylinder liner I.D. at the six positions (see figure) with a cylinder gauge to find the maximum and minimum I.D.'s.
2. Get the difference (Maximum wear) between the maximum and the minimum I.D.'s.
3. If the wear exceeds the allowable limit, bore and hone to the oversize dimension. (Refer to "Correcting Cylinder".)
4. Visually check the cylinder wall for scratches. If deep scratches are found, the cylinder should be bored. (Refer to "Correcting Cylinder".)

Cylinder liner I.D.	Factory specification	Z482-E4B D722-E4B D782-E4B	67.000 to 67.019 mm 2.6378 to 2.6385 in.
		Z602-E4B D902-E4B	72.000 to 72.019 mm 2.8347 to 2.8353 in.
	Allowable limit	Z482-E4B D722-E4B D782-E4B	67.150 mm 2.6437 in.
		Z602-E4B D902-E4B	72.150 mm 2.8406 in.

- (A) Top
- (B) Middle
- (C) Bottom (Skirt)

- (a) Right-angled to piston pin
- (b) Piston pin direction

9Y1210785ENS0096US0

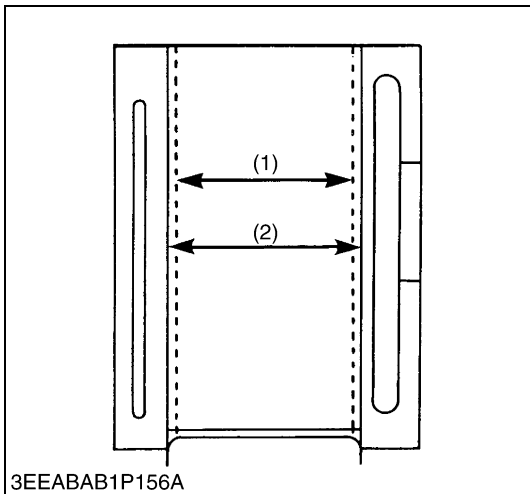

Correcting Cylinder (Oversize)

1. When the cylinder is worn beyond the allowable limit, bore and hone it to the specified dimension.

Cylinder liner I.D.	Factory specification	Z482-E4B	67.250 to 67.269 mm
		D722-E4B	2.6477 to 2.6483 in.
	Allowable limit	Z602-E4B	72.250 to 72.269 mm
		D902-E4B	2.8445 to 2.8452 in.
Finishing	Hone to 2.2 to 3.0 μm Rz (87 to 110 μin. Rz)		

2. Replace the piston and piston rings with oversize ones.
Oversize : 0.25 mm (0.0098 in.)
Marking : 025

NOTE

- When the oversize cylinder is worn beyond the allowable limit, replace the cylinder block with a new one.

(1) Cylinder I.D. (Before Correction) (2) Cylinder I.D. [Oversize]

9Y1210785ENS0097US0

(6) Oil Pump



Rotor Lobe Clearance

1. Measure the clearance between lobes of the inner rotor and the outer rotor with a thickness gauge.
2. If the clearance exceeds the factory specifications, replace the oil pump rotor assembly.

Rotor lobe clearance	Factory specification	0.030 to 0.14 mm 0.0012 to 0.0055 in.
----------------------	-----------------------	--

9Y1210785ENS0098US0

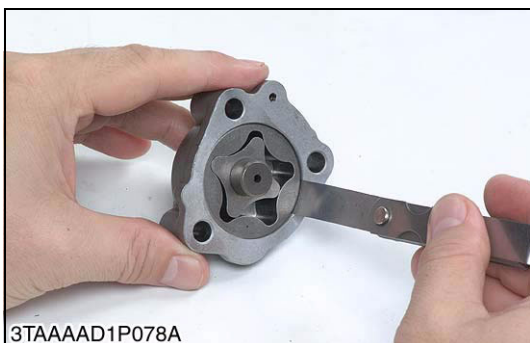

Clearance between Outer Rotor and Pump Body

1. Measure the clearance between the outer rotor and the pump body with a thickness gauge.
2. If the clearance exceeds the factory specifications, replace the oil pump rotor assembly.

Clearance between outer rotor and pump body	Factory specification	0.070 to 0.15 mm 0.0028 to 0.0059 in.
---	-----------------------	--

9Y1210785ENS0099US0

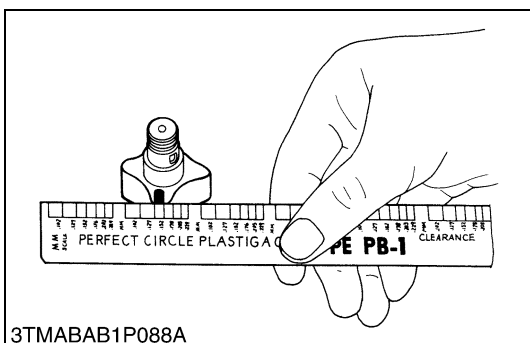

Clearance between Rotor and Cover

1. Put a strip of plastigage onto the rotor face with grease.
2. Install the cover and tighten the screws.
3. Remove the cover carefully, and measure the amount of the flattening with the scale and get the clearance.
4. If the clearance exceeds the factory specifications, replace oil pump rotor assembly.

Clearance between rotor and cover	Factory specification	0.0750 to 0.135 mm 0.00296 to 0.00531 in.
-----------------------------------	-----------------------	--

9Y1210785ENS0100US0

(7) Starter

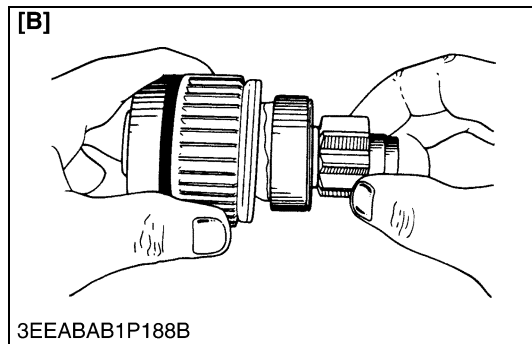
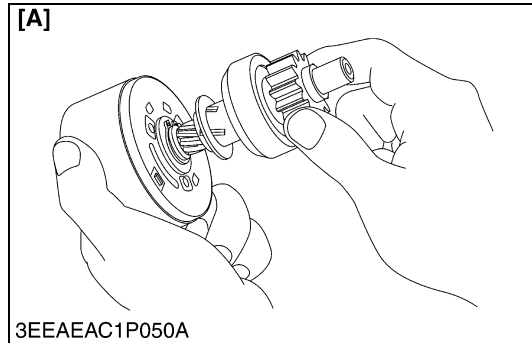

Overrunning Clutch

1. Check the pinion and if worn or damaged, replace the clutch assembly.
2. Check that the pinion turns freely and smoothly in the overrunning direction and does not slip in the cranking direction.
3. If the pinion slips or does not turn in both directions, replace the overrunning clutch assembly.

■ NOTE

- Do not wash off the grease in the overrunning clutch with the chemicals or oils.

[A] Electromagnetic Drive Type

[B] Planetary Gear Reduction Type

9Y1210785ENS0101US0

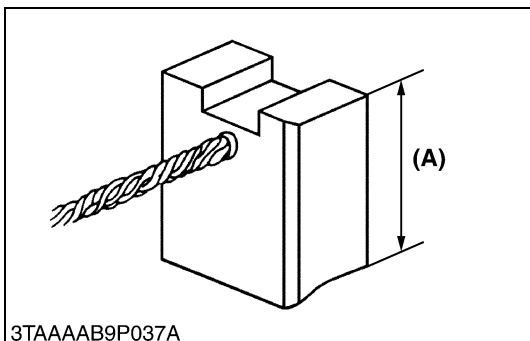
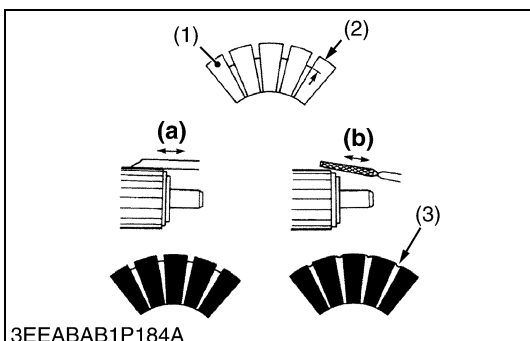
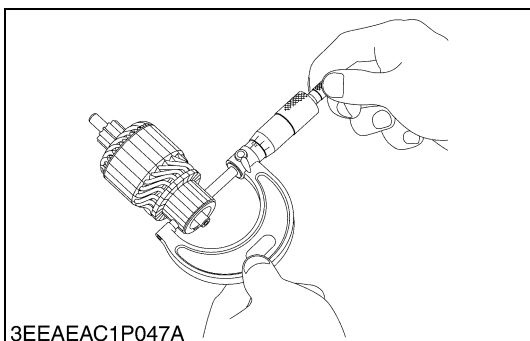
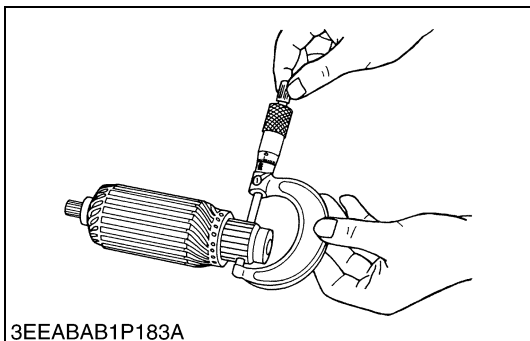
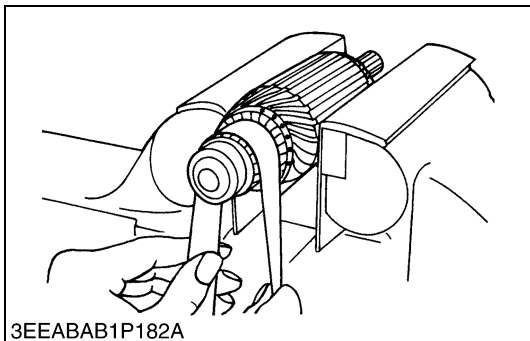

Commutator and Mica

1. Check the contact of the commutator for wear, and grind the commutator with emery paper if it is slightly worn.
2. Measure the commutator O.D. with an outside micrometer at several points.
3. If the minimum O.D. is less than the allowable limit, replace the armature.
4. If the difference of the O.D.'s exceeds the allowable limit, correct the commutator on a lathe to the factory specification.
5. Measure the mica undercut.
6. If the undercut is less than the allowable limit, correct it with a saw blade and chamfer the segment edges.

Commutator O.D.	Factory specification	Electromagnetic drive type	28.0 mm 1.10 in.
		Planetary gear reduction type	30.0 mm 1.18 in.
	Allowable limit	Electromagnetic drive type	27.0 mm 1.06 in.
		Planetary gear reduction type	29.0 mm 1.14 in.

Difference of O.D.'s	Factory specification	Electromagnetic drive type	Less than 0.05 mm 0.002 in.
		Planetary gear reduction type	Less than 0.02 mm 0.0008 in.
	Allowable limit	Electromagnetic drive type	0.40 mm 0.016 in.
		Planetary gear reduction type	0.05 mm 0.002 in.

Mica under cut	Factory specification	0.50 to 0.80 mm 0.020 to 0.031 in.
	Allowable limit	0.20 mm 0.0079 in.

- | | |
|-------------------|---------------|
| (1) Segment | (a) Correct |
| (2) Depth of Mica | (b) Incorrect |
| (3) Mica | |

9Y1210785ENS0102US0

Brush Wear

1. If the connect face of the brush is dirty or dusty, clean it with emery paper.
2. Measure the brush length (A) with vernier caliper.
3. If the length is than the allowable limit, replace the yoke assembly and brush holder.

Brush length (A)	Factory specification	Electromagnetic drive type	16.0 mm 0.630 in.
		Planetary gear reduction type	14.0 mm 0.551 in.
	Allowable limit	Electromagnetic drive type	10.5 mm 0.413 in.
		Planetary gear reduction type	9.0 mm 0.35 in.

9Y1210785ENS0103US0

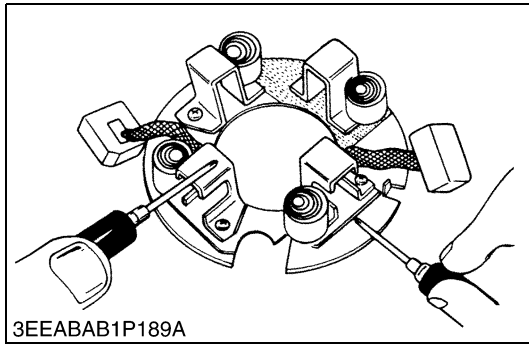

3EEABAB1P189A

Brush Holder

1. Check the continuity across the brush holder and the holder support with a circuit tester.
2. If it conducts, replace the brush holder.

9Y1210785ENS0104US0

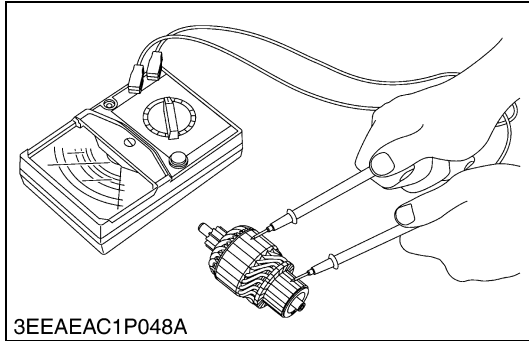

3EEAEAC1P048A

Armature Coil

1. Check the continuity across the commutator and armature coil with resistance range of circuit tester.
2. If it conducts, replace the armature.
3. Check the continuity across the segments of the commutator with resistance range of circuit tester.
4. If it does not conduct, replace the armature.

9Y1210785ENS0105US0

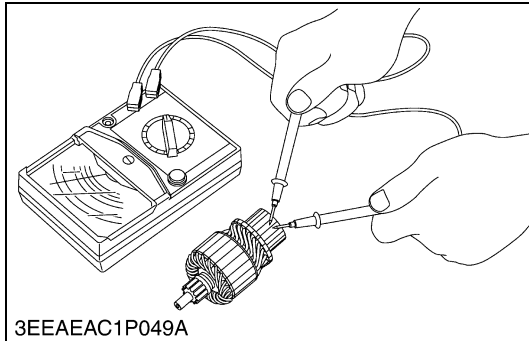

3EEAEAC1P049A

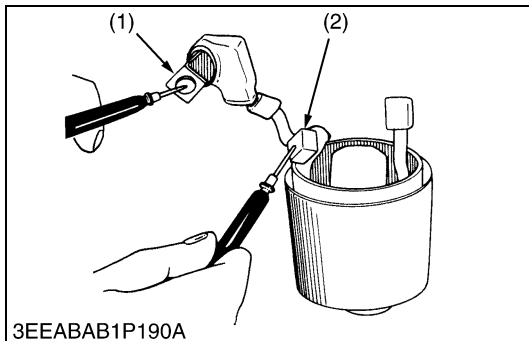

3EEABAB1P190A

Field Coil

1. Check the continuity across the lead (1) and brush (2) with a circuit tester.
2. If it does not conduct, replace the yoke assembly.
3. Check the continuity across the brush (2) and yoke (3) with a circuit tester.
4. If it conducts, replace the yoke assembly.

(1) Lead
(2) Brush

(3) Yoke

9Y1210785ENS0106US0

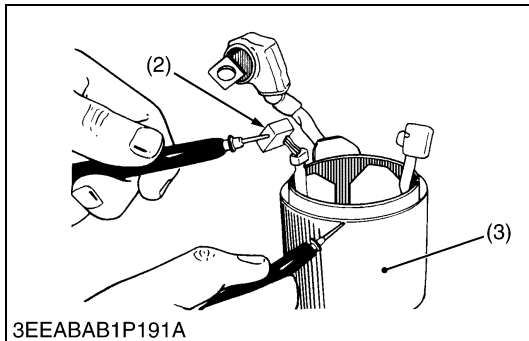

3EEABAB1P191A

(8) Alternator

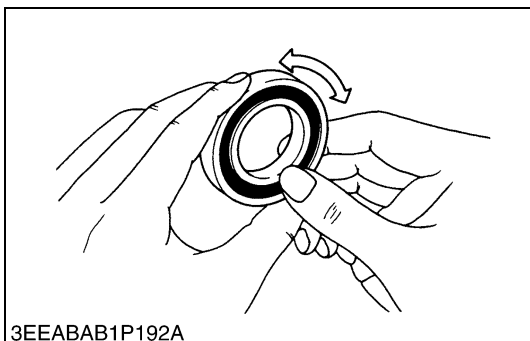

3EEABAB1P192A

Bearing

1. Check the bearing for smooth rotation.
2. If it does not rotate smoothly, replace it.

9Y1210785ENS0107US0

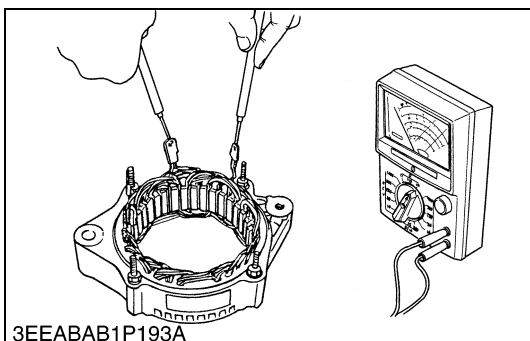

3EEABAB1P193A

Stator

1. Measure the resistance across each lead of the stator coil with resistance range of circuit tester.
2. If the measurement is not within factory specification, replace it.
3. Check the continuity across each stator coil lead and core with resistance range of circuit tester.
4. If infinity is not indicated, replace it.

Resistance	Factory specification	Less than 1.0 Ω
------------	-----------------------	-----------------

9Y1210785ENS0108US0

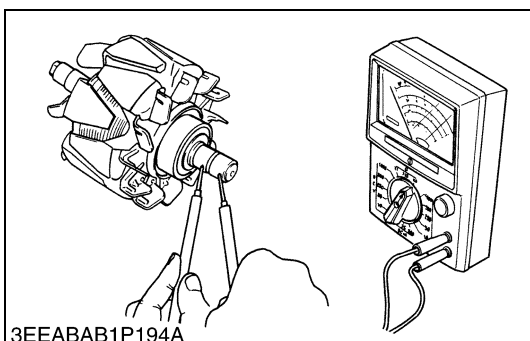

3EEABAB1P194A

Rotor

1. Measure the resistance across the slip rings.
2. If the resistance is not the factory specification, replace it.
3. Check the continuity across the slip ring and core with resistance range of circuit tester.
4. If infinity is not indicated, replace it.

Resistance	Factory specification	2.9 Ω
------------	-----------------------	-------

9Y1210785ENS0109US0

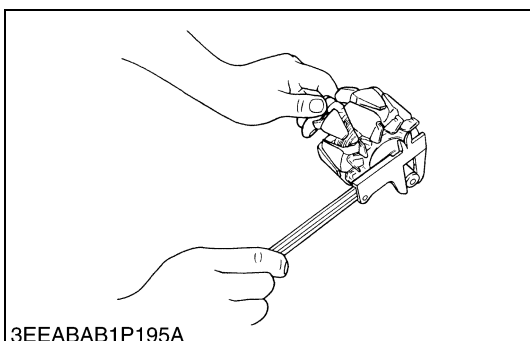

3EEABAB1P195A

Slip Ring

1. Check the slip ring for score.
2. If scored, correct with an emery paper or on a lathe.
3. Measure the O.D. of slip ring with vernier calipers.
4. If the measurement is less than the allowable limit, replace it.

Slip ring O.D.	Factory specification	14.4 mm 0.567 in.
	Allowable limit	14.0 mm 0.551 in.

9Y1210785ENS0110US0

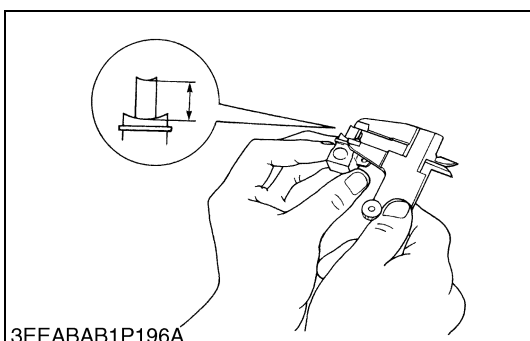

3EEABAB1P196A

Brush Wear

1. Measure the brush length with vernier calipers.
2. If the measurement is less than allowable limit, replace it.
3. Make sure that the brush moves smoothly.
4. If the brush is defective, replace it.

Brush length	Factory specification	10.0 mm 0.394 in.
	Allowable limit	8.4 mm 0.33 in.

9Y1210785ENS0111US0

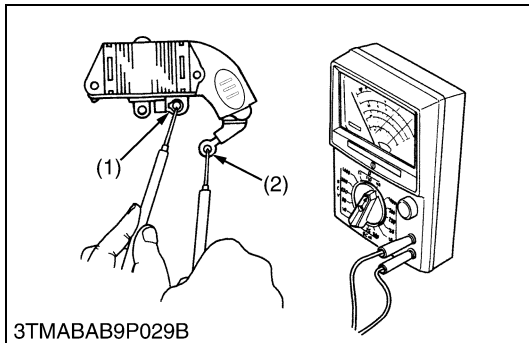
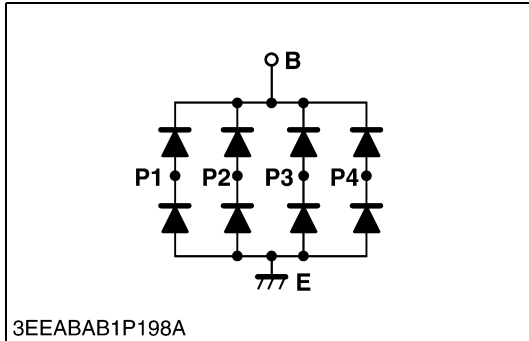
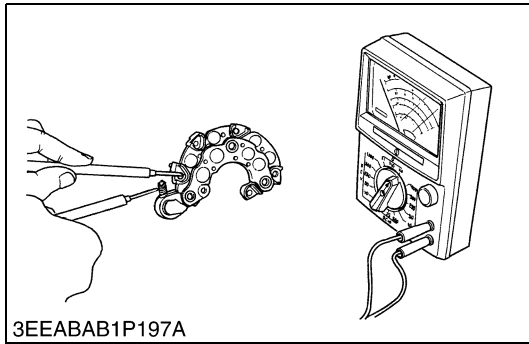

Rectifier

1. Check the continuity across each diode of rectifier with resistance range of circuit tester.
2. The rectifier is normal if the diode in the rectifier conducts in one direction and does not conduct in the reverse direction.

9Y1210785ENS0112US0

IC Regulator

1. Check the continuity across the **B** terminal (2) and the **F** terminal (1) of IC regulator with resistance range of circuit tester.
2. The IC regulator is normal if the conducts in one direction and does not conduct in the reverse direction.

(1) **F** Terminal(2) **B** Terminal

9Y1210785ENS0113US0

EDITOR:

KUBOTA FARM & INDUSTRIAL MACHINERY SERVICE, LTD.

64, ISHIZU-KITAMACHI, SAKAI-KU, SAKAI-CITY, OSAKA, 590-0823, JAPAN

PHONE : (81)72-241-1129

FAX : (81)72-245-2484

E-mail : ks_g.ksos-pub@kubota.com
