



Count on it.

Operator's Manual

Workman® HDX-Auto Utility Vehicle

Model No. 07390—Serial No. 315000001 and Up

Model No. 07390H—Serial No. 315000001 and Up

Model No. 07390TC—Serial No. 315000001 and Up



This product complies with all relevant European directives. For details, please see the separate product specific Declaration of Conformity (DOC) sheet.

⚠ WARNING

**CALIFORNIA
Proposition 65 Warning**

This product contains a chemical or chemicals known to the State of California to cause cancer, birth defects, or reproductive harm.

The engine exhaust from this product contains chemicals known to the State of California to cause cancer, birth defects, or other reproductive harm.

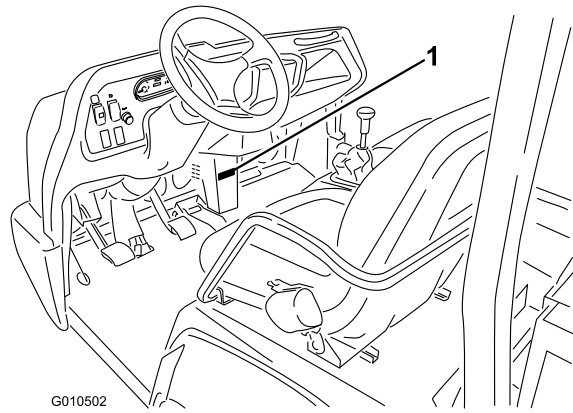

G010502

Figure 1

1. Model and serial number location

Model No. _____
Serial No. _____

Important: The engine in this product is not equipped with a spark arrested muffler. It is a violation of California Public Resource code Section 4442 to use or operate this engine on any forest-covered, brush covered, or grass-covered land as defined in CPRC 4126. Other states or federal areas may have similar laws.

This manual identifies potential hazards and has safety messages identified by the safety alert symbol (Figure 2), which signals a hazard that may cause serious injury or death if you do not follow the recommended precautions.

Introduction

This machine is a utility vehicle intended to be used by professional, hired operators in commercial applications. It is primarily designed for the transport of implements used in such applications. This vehicle allows for the safe transport of an operator and one passenger in the identified seats. The bed of this vehicle is not suitable for any riders.

Read this information carefully to learn how to operate and maintain your product properly and to avoid injury and product damage. You are responsible for operating the product properly and safely.

You may contact Toro directly at www.Toro.com for product safety and operation training materials, accessory information, help finding a dealer, or to register your product.

Whenever you need service, genuine Toro parts, or additional information, contact an Authorized Service Dealer or Toro Customer Service and have the model and serial numbers of your product ready. Figure 1 identifies the location of the model and serial numbers on the product. Write the numbers in the space provided.



Figure 2

1. Safety-alert symbol

This manual uses 2 words to highlight information. **Important** calls attention to special mechanical information and **Note** emphasizes general information worthy of special attention.

Contents

Safety	4	Jacking the Machine	37
Safe Operating Practices	4	Removing and Installing the Hood	38
Supervisor's Responsibilities	4	Lubrication	39
Before Operating	4	Greasing the Bearings and the Bushings	39
Safe Handling of Fuels	4	Engine Maintenance	40
Operation	5	Servicing the Air Filter	40
Maintenance	6	Changing the Engine Oil and Filter	41
Rollover Protection System (ROPS) - Use and		Replacing the Spark Plug	42
Maintenance	6	Fuel System Maintenance	42
Hauling	6	Replacing the Fuel Filter	42
Sound Pressure	7	Inspecting the Carbon Canister Air Filter	43
Vibration	7	Inspecting the Fuel Lines and Connections	43
Safety and Instructional Decals	7	Electrical System Maintenance	43
Setup	12	Servicing the Fuses	43
1 Installing the Steering Wheel (TC and H Models		Jump-Starting the Machine	44
only)	12	Servicing the Battery	45
2 Installing the ROPS	13	Drive System Maintenance	45
3 Connecting the Battery (TC and H Models		Maintaining the Tires, Wheels, and	
only)	13	Suspension	45
4 Connecting the CVT Intake Duct (TC and H		Maintaining the Transmission	47
Models only)	14	Maintaining the Differential and Axles	50
5 Checking the Fluid Levels	15	Cooling System Maintenance	51
Product Overview	15	Changing the Engine Coolant	51
Controls	15	Brake Maintenance	52
Dashboard Switches	17	Adjusting the Parking Brake	52
Instrument Cluster	17	Adjusting the Brake Pedal	53
Specifications	19	Controls System Maintenance	54
Attachments/Accessories	19	Converting the Speedometer	54
Operation	19	Adjusting the Accelerator Pedal	54
Operating the Cargo Box	19	Hydraulic System Maintenance	57
Checking the Fluid Levels	20	Replacing the Hydraulic Filter	57
Checking the Oil Pressure Warning Light	24	Changing the Hydraulic Fluid	57
Adding Fuel	25	Raising the Box in an Emergency	58
Checking the Tire Pressure	26	Storage	59
Removing Debris from the Cooling System	26	Troubleshooting	61
Performing Pre-start Checks	26		
Starting the Engine	27		
Driving the Vehicle	27		
Stopping the Vehicle	27		
Stopping the Engine	27		
Using the Speed-range Control	27		
Using the Differential Lock	28		
Breaking in a New Machine	28		
Checking the Interlock System	29		
Transporting the Machine	29		
Towing the Machine	30		
Towing a Trailer with the Machine	30		
Using the Hydraulic Control	30		
Operating Tips	31		
Maintenance	34		
Recommended Maintenance Schedule(s)	34		
Heavy Duty Operation	35		
Pre-maintenance Procedures	35		
Using the Bed Safety Support	36		
Removing the Full Bed	36		
Installing the Full Bed	37		

Safety

The machine meets the requirements of SAE J2258.

Safe Operating Practices

Important: The machine is designed primarily as an off-road vehicle and is not intended for extensive use on public roads.

When using the machine on public roads, follow all traffic regulations and use any additional accessories that may be required by law, such as lights, turn signals, slow moving vehicle (SMV) sign, and others as required.

The Workman was designed and tested to offer safe service when operated and maintained properly. Although hazard control and accident prevention partially are dependent upon the design and configuration of the machine, these factors are also dependent upon the awareness, concern, and proper training of the personnel involved in the operation, maintenance and storage of the machine. Improper use or maintenance of the machine can result in injury or death.

This is a specialized utility vehicle designed for off-road use only. Its ride and handling will have a different feel than what drivers experience with passenger cars or trucks. So take time to become familiar with your machine.

Not all of the attachments that adapt to the machine are covered in this manual. See the specific *Operator's Manual* provided with each attachment for additional safety instructions. **Read these manuals.**

To reduce the potential for injury or death, comply with the following safety instructions:

Supervisor's Responsibilities

- Make sure operators are thoroughly trained and familiar with the *Operator's Manual* and all labels on the vehicle.
- Be sure to establish your own special procedures and work rules for unusual operating conditions (e.g. slopes too steep for the safe operation of the machine).

Before Operating

- Operate the machine only after reading and understanding the contents of this manual. A replacement manual is available by sending complete model and serial number to: The Toro® Company, 8111 Lyndale Avenue South, Minneapolis, Minnesota 55420.
- This machine is designed to carry **only you**, the operator, and **one passenger** in the seat provided by the manufacturer. **Never** carry any other passengers on the vehicle.
- Become familiar with the controls and know how to stop the engine quickly.
- **Never** operate the machine when under the influence of drugs or alcohol.

- Always wear substantial shoes. Do not operate the machine while wearing sandals, tennis shoes, or sneakers. Do not wear loose fitting clothing or jewelry which could get caught in moving parts and cause personal injury.
- Wearing safety glasses, substantial safety shoes, long pants, and a helmet is advisable and required by some local safety and insurance regulations.
- **Never** allow children to operate the machine. **Never** allow adults to operate it without proper instructions. Only trained and authorized persons should operate this machine. Make sure all operators are physically and mentally capable of operating the machine.
- Keep everyone, especially children and pets, away from the areas of operation.
- Check the safety interlock system daily for proper operation. If a switch should malfunction, replace the switch before operating machine.
- Keep all shields, safety devices and decals in place. If a shield, safety device or decal is malfunctioning, illegible, or damaged, repair or replace it before operating the machine.
- Before operating the vehicle, always check all parts of the vehicle and any attachments. If something is wrong, **stop using vehicle**. Make sure the problem is corrected before vehicle or attachment is operated again.
- Use only an approved nonmetal, portable fuel container. Static electric discharge can ignite fuel vapors in a fuel container that is not grounded. Remove the fuel container from the bed of the machine and place it on the ground and away from the vehicle before filling. Keep the nozzle in contact with the container while filling the fuel container. Remove equipment from bed of the machine before fueling it.
- Operate the machine only outdoors or in a well ventilated area.

Safe Handling of Fuels

- To avoid personal injury or property damage, use extreme care in handling gasoline. Gasoline is extremely flammable and the vapors are explosive.
- Extinguish all cigarettes, cigars, pipes, and other sources of ignition.
- Use only an approved fuel container.
- Never remove fuel cap or add fuel with the engine running.
- Allow engine to cool before refueling.
- Never refuel the machine indoors.
- Never store the machine or fuel container where there is an open flame, spark, or pilot light such as on a water heater or on other appliances.
- Never fill containers inside a vehicle or on a truck or trailer bed with a plastic liner. Always place containers on the ground away from your vehicle before filling.

- Remove equipment from the truck or trailer and refuel it on the ground. If this is not possible, then refuel such equipment with a portable container, rather than from a fuel dispenser nozzle.
- Keep the nozzle in contact with the rim of the fuel tank or container opening at all times until fueling is complete. Do not use a nozzle lock open device.
- If fuel is spilled on clothing, change clothing immediately.
- Never overfill fuel tank. Replace fuel cap and tighten securely.

Operation

- The operator and passenger should remain seated and use the seat belts whenever the vehicle is in motion. The operator should keep both hands on the steering wheel, whenever possible, and the passenger should use the hand holds provided. Keep arms and legs within the vehicle body at all times. Never carry passengers in the box or on attachments. Remember your passenger may not be expecting you to brake or turn and may not be ready.
- Never overload your vehicle. The name plate (located under the middle of the dash) shows the load limits for the vehicle. Never overfill attachments or exceed the vehicle maximum gross vehicle weight (GVW).
- When starting the engine:
 - Sit on operator’s seat and ensure that the parking brake is engaged.
 - Disengage PTO (if so equipped) and return the hand throttle lever to the Off position (if so equipped).
 - Make sure the hydraulic lift lever is in the center position.
 - Press in the brake pedal.
 - Keep your foot off of the accelerator pedal.
 - Turn the ignition key to the Start position.
- Using the machine demands attention. Failure to operate machine safely may result in an accident, tip over of the machine, and serious injury or death. Drive carefully. To prevent tipping or loss of control, take the following precautions:
 - Use extreme caution, reduce speed, and maintain a safe distance around sand traps, ditches, creeks, ramps, any unfamiliar areas, or other hazards.
 - Watch for holes or other hidden hazards.
 - Use caution when operating the vehicle on a steep slope. Normally, travel straight up and down slopes. Reduce speed when making sharp turns or when turning on hillsides. Avoid turning on hillsides whenever possible.
 - Use extra caution when operating the machine on wet surfaces, at higher speeds, or with a full load. Stopping time will increase with a full load.
 - When loading the bed, distribute the load evenly. Use extra caution if the load exceeds the dimensions of the vehicle/bed. Operate the machine with extra caution when handling off-center loads that cannot be centered. Keep loads balanced and secure to prevent them from shifting.
- Avoid sudden stops and starts. Do not go from reverse to forward or forward to reverse without first coming to a complete stop.
- Do not attempt sharp turns or abrupt maneuvers or other unsafe driving actions that may cause a loss of control of the machine.
- Do not pass another machine traveling in the same direction at intersections, blind spots, or at other dangerous locations.
- When dumping, do not let anyone stand behind machine and do not dump the load on anyone’s feet. Release the tailgate latches from the side of box, not from behind.
- Keep all bystanders away. Before backing up, look to the rear and ensure that no one is behind the vehicle. Back up slowly.
- Watch out for traffic when near or crossing roads. Always yield the right of way to pedestrians and other vehicles. Always signal your turns or stop early enough so other persons know what you plan to do. Obey all traffic rules and regulations.
- Never operate the machine in or near an area where there is dust or fumes in the air which are explosive. The electrical and exhaust systems of the machine can produce sparks capable of igniting explosive materials.
- Always watch out for and avoid low overhangs such as tree limbs, door jambs, over head walkways, etc. Make sure there is enough room over head to easily clear the machine and your head.
- If you are ever unsure about the safe operation of the machine, **stop your work** and ask your supervisor.
- Before getting off the seat:
 - Stop movement of the machine.
 - Lower bed.
 - Shut engine off and wait for all movement to stop.
 - Set parking brake.
 - Remove key from ignition.
- Do not touch engine, transmission, radiator, muffler or muffler manifold while engine is running or soon after it has stopped because these areas may be hot enough to cause burns.
- If the machine ever vibrates abnormally, stop the machine immediately, turn engine off, wait for all motion to stop and inspect for damage. Repair all damage before resuming operation.
- Lightning can cause severe injury or death. If lightning is seen or thunder is heard in the area, do not operate the machine; seek shelter.

Maintenance

- Before servicing or making adjustments to the machine, move the machine to a level surface, stop the engine, set the parking brake, and remove the key from ignition to prevent accidental starting of the engine.
- Never work under a raised bed without placing the bed-safety support onto the fully extended bed-actuator rod.
- Make sure all hydraulic fittings are tight, and all hydraulic hoses and lines are in good condition before applying pressure to the system.
- Keep your body and hands away from pin hole leaks or nozzles that eject hydraulic fluid under high pressure. Use paper or cardboard, **not your hands**, to search for leaks. Hydraulic fluid escaping under pressure can have sufficient force to penetrate skin and cause serious damage to your body. If fluid is injected into the skin, it must be surgically removed within a few hours by a doctor familiar with this form of injury, or gangrene may result.
- Before disconnecting or performing any work on the hydraulic system, all pressure in the hydraulic system must be relieved by stopping the engine and cycling the hydraulic control valve for the bed lift from raise to lower and/or lowering box and attachments. If equipped, place the remote-hydraulics lever in the float position. If the box must be in raised position, secure it with the bed-safety support.
- To make sure the entire machine is in good condition, keep all nuts, bolts, and screws properly tightened.
- To reduce the potential fire hazard, keep the engine area free of excessive grease, grass, leaves, and accumulation of dirt.
- If the engine must be running to perform a maintenance adjustment, keep hands, feet, clothing, and any parts of the body away from the engine and any moving parts. Keep everyone away.
- Do not overspeed the engine by changing the governor settings. The maximum engine speed is 3650 rpm. To ensure safety and accuracy, have an Authorized Toro Distributor check the maximum engine speed with a tachometer.
- If major repairs are ever needed or assistance is required, contact an Authorized Toro Distributor.
- To be sure of optimum performance and safety, always purchase genuine Toro replacement parts and accessories. Replacement parts and accessories made by other manufacturers could be dangerous. Altering this machine in any manner may affect the operation, performance, durability of the machine, or its use may result in injury or death. Such use could void the product warranty of The Toro® Company.
- This machine should not be modified without authorization from The Toro® Company. Direct any

inquiries to The Toro® Company, Commercial Division, Vehicle Engineering Dept., 8111 Lyndale Ave. So., Bloomington, Minnesota 55420-1196 USA.

Rollover Protection System (ROPS) - Use and Maintenance

- The ROPS is an integral and effective safety device. Use the seat belt when operating the machine with ROPS.
- Be certain that the seat belt can be released quickly in the event of an emergency.
- Check carefully for overhead clearances (i.e. branches, doorways, electrical wires) before driving under any objects and do not contact them.
- Keep the ROPS in safe operating condition by periodically thoroughly inspecting for damage and keeping all mounting fasteners tight.
- Replace a damaged ROPS. Do not repair or revise.
- **Do not** remove the ROPS.
- Any alterations to a ROPS must be approved by the manufacturer.

Hauling

- Use care when loading or unloading the machine into a trailer or truck.
- Use full width ramps for loading machine into trailer or truck.
- Tie the machine down securely using straps, chains, cable, or ropes. Both front and rear straps should be directed down and outward from the machine.

Sound Pressure

This unit has a sound pressure level at the operator's ear of 79 dBA, which includes an Uncertainty Value (K) of 1 dBA.

The sound pressure level was determined according to the procedures outlined in EN ISO 11201.

Vibration

Hand-Arm

- Measured vibration level for right hand = 0.3 m/s²

- Measured vibration level for left hand = 0.4 m/s²
- Uncertainty Value (K) = 0.2 m/s²

Measured values were determined according to the procedures outlined in EN ISO 20643.

Whole Body

- Measured vibration level = 0.18 m/s²
- Uncertainty Value (K) = 0.09 m/s²

Measured values were determined according to the procedures outlined in EN 1032.

Safety and Instructional Decals



Safety decals and instructions are easily visible to the operator and are located near any area of potential danger. Replace any decal that is damaged or lost.



106-6755

- Engine coolant under pressure.
- Explosion hazard—read the *Operator's Manual*.
- Warning—do not touch the hot surface.
- Warning—read the *Operator's Manual*.

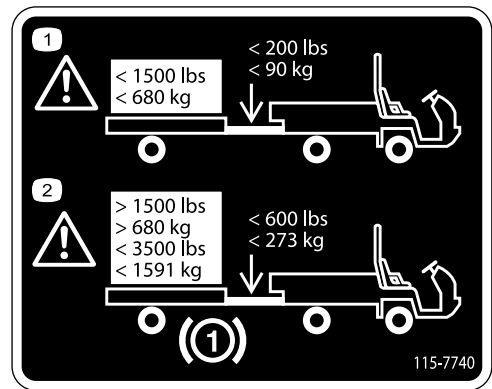

115-7740

- Warning—maximum trailer weight is 680 kg (1500 lb); maximum tongue weight is 90 kg (200 lb).
- Warning—trailer brakes are required when towing greater than 680 kg (1500 lb). Maximum trailer weight with trailer brakes is 1591 kg (3500 lb) maximum tongue weight with trailer brakes is 273 kg (600 lb).

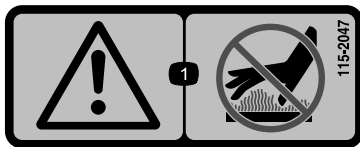

115-2047

- Warning—do not touch the hot surface.

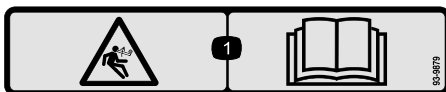

93-9879

- Stored energy hazard—read the *Operator's Manual*.



115-7756

- High flow hydraulics—engaged

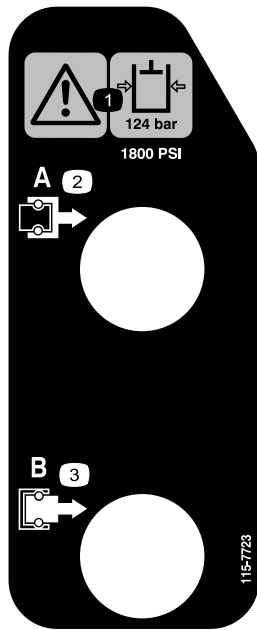

115-7723

1. Warning—the hydraulic oil pressure is 124 bar (1800 psi).
2. Coupler A
3. Coupler B



93-9899

1. Crushing hazard—install the cylinder lock.

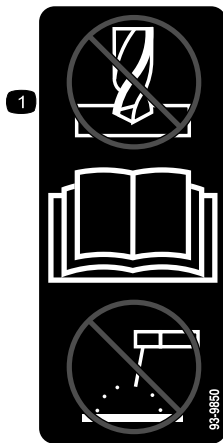

93-9850

1. Do not repair or revise—read the *Operator's Manual*.



106-7767

1. Warning—read the *Operator's Manual*; avoid tipping the machine; wear the seat belt; lean away from the direction the machine is tipping.

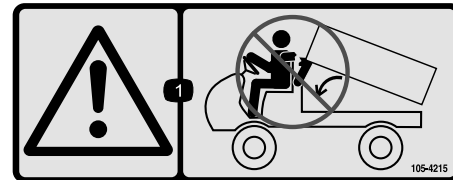

105-4215

1. Warning—avoid pinch points.

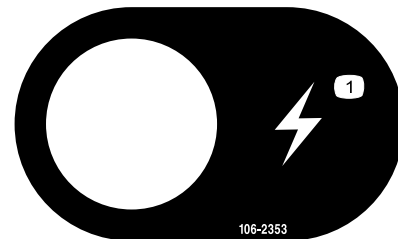

106-2353

1. Electrical power point

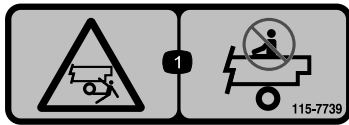

115-7739

1. Falling, crushing hazard, bystanders—no riders on machine.

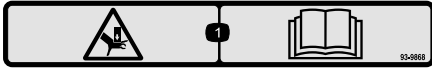

93-9868

1. Crushing hazard of hand—read the *Operator's Manual*.



Battery Symbols

Some or all of these symbols are on your battery.

- | | |
|--|--|
| 1. Explosion hazard | 6. Keep bystanders a safe distance from the battery. |
| 2. No fire, open flame, or smoking. | 7. Wear eye protection; explosive gases can cause blindness and other injuries |
| 3. Caustic liquid/chemical burn hazard | 8. Battery acid can cause blindness or severe burns. |
| 4. Wear eye protection | 9. Flush eyes immediately with water and get medical help fast. |
| 5. Read the <i>Operator's Manual</i> . | 10. Contains lead; do not discard. |



115-2282

1. Warning—read the *Operator's Manual*.
2. Warning—stay away from moving parts and keep all guards and shields in place.
3. Crushing/dismemberment hazard of bystanders—keep bystanders a safe distance from the vehicle, do not carry passengers in the cargo bed, keep arms and legs inside of the vehicle at all times, and use seat belts and handholds.



93-9852

1. Warning—read the *Operator's Manual*.
2. Crushing hazard—install the cylinder lock.



105-7977

1. Tank
2. Pressure

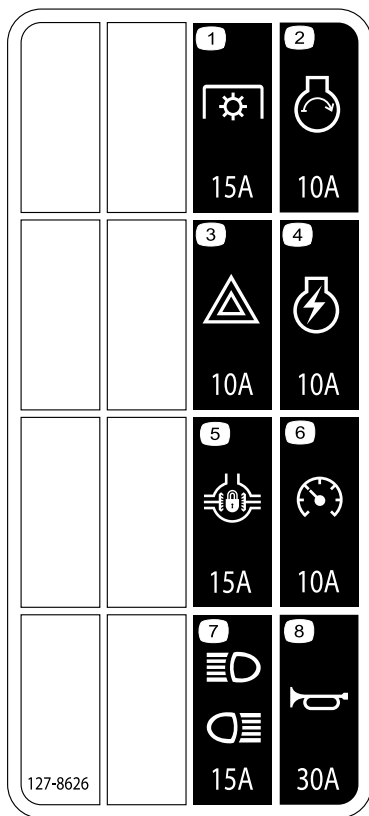

127-8626

- | | |
|------------------------|-----------------------------------|
| 1. Power take-off—15A | 5. Differential lock—15A |
| 2. Engine start—10A | 6. Speedometer—10A |
| 3. Hazards—10A | 7. Headlights and rear lights—15A |
| 4. Engine ignition—10A | 8. Horn—30A |

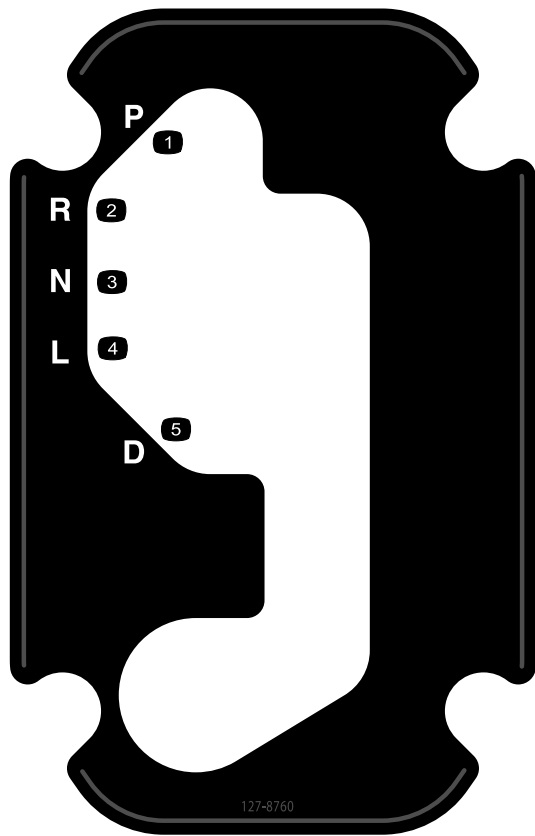

127-8760

- | | |
|------------|-------------|
| 1. Park | 4. Low gear |
| 2. Reverse | 5. Drive |
| 3. Neutral | |



115-7746

- | | |
|---|--|
| 1. Warning—do not operate this machine unless you are trained. | 3. Fire hazard—stop the engine before fueling. |
| 2. Warning—lock the parking brake, stop the engine, and remove the ignition key before leaving the machine. | 4. Tipping hazard—slow down and turn gradually, use caution and drive slowly when driving on slopes, do not exceed 32 kph (20 mph), and drive slowly over rough terrain or when carrying a full or heavy load. |

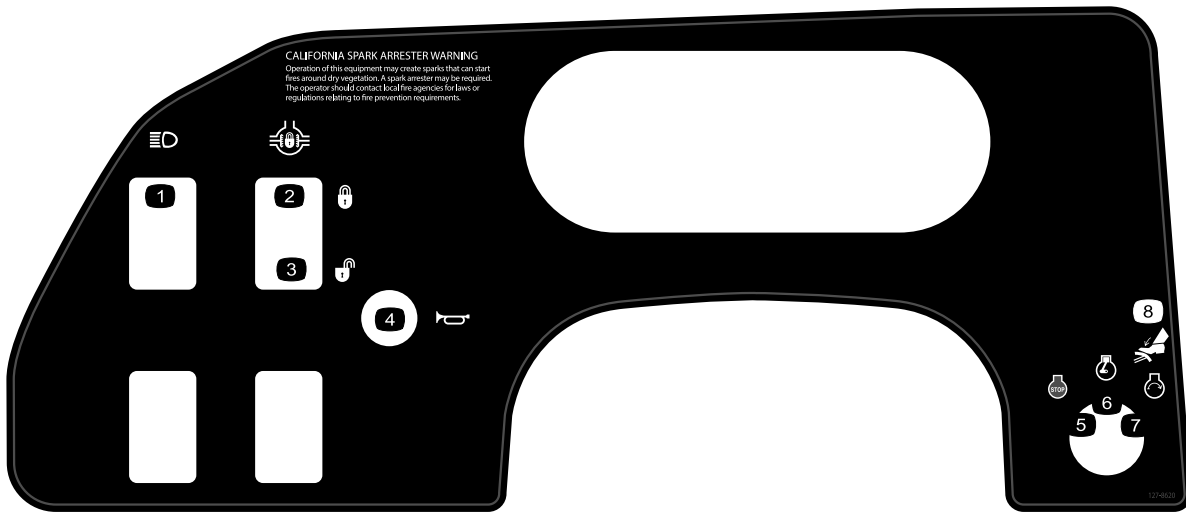

127-8620

- | | | |
|-----------------------------|----------------|-----------------|
| 1. Head lights | 4. Horn | 7. Engine—start |
| 2. Differential lock—lock | 5. Engine—stop | 8. Brake |
| 3. Differential lock—unlock | 6. Engine—run | |

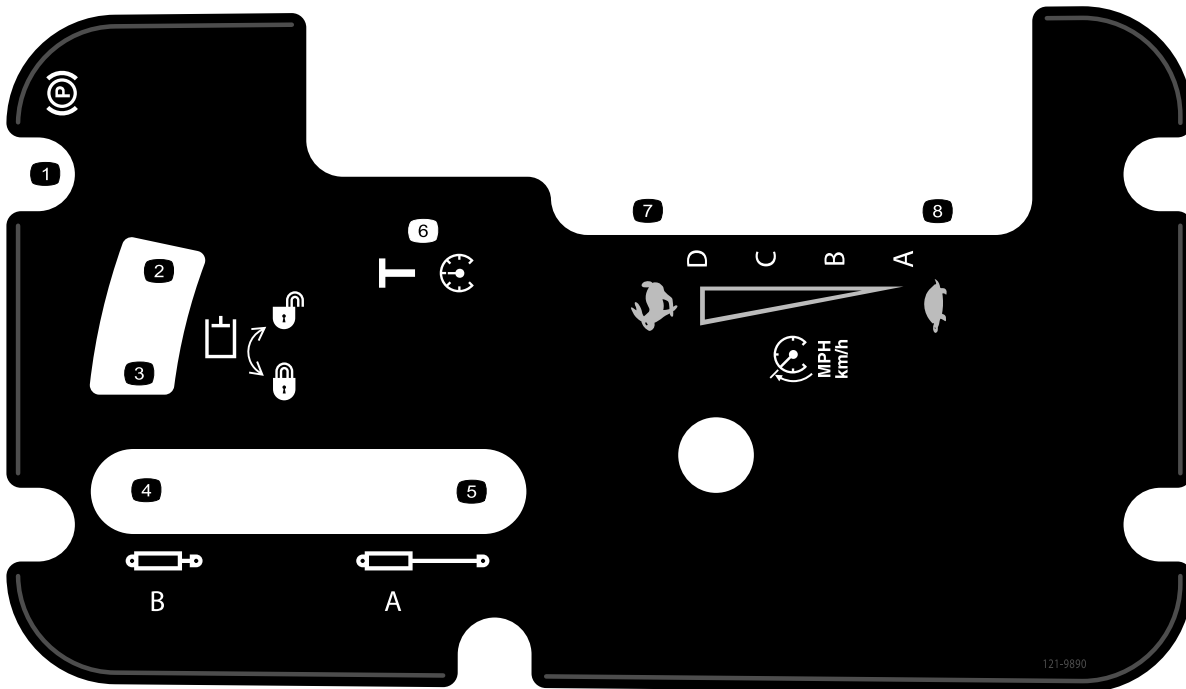

121-9890

- | | | |
|----------------------------|---------------------|---------|
| 1. Parking brake | 4. Cylinder retract | 7. Fast |
| 2. Unlock—hydraulic system | 5. Cylinder extend | 8. Slow |
| 3. Lock— hydraulic system | 6. Transport | |

Setup

Loose Parts

Use the chart below to verify that all parts have been shipped.

Procedure	Description	Qty.	Use
1	Steering wheel	1	Install the steering wheel.
	Cover	1	
	Washer (5/8 inch)	1	
2	ROPS frame	1	Mount the ROPS (Rollover Protection System).
	Flange-head bolt (1/2 x 1-1/4 inch)	6	
3	No parts required	–	Connect the battery.
4	No parts required	–	Connect the continuously variable transmission intake duct.
5	No parts required	–	Check the engine oil, transaxle/hydraulic fluid, coolant, and brake fluid levels.

Media and Additional Parts

Description	Qty.	Use
Operator's Manual	1	Read before operating the vehicle.
Parts Manual	1	Use to reference part numbers.
Operator Training Material	1	View before operating the machine.
CVT Kit 121-9853	1	Connecting the CVT Intake Duct (TC and H Models Only)
CVT Adapter 127-8750	1	Connecting the CVT Intake Duct (TC and H Models Only)

Note: Determine the left and right side of the machine from the normal operating position.



- Secure the steering wheel to the shaft with the nut and tighten it to 27–34 N-m (20-25 ft-lb).
- Install the cover on the steering wheel (Figure 3).

Installing the Steering Wheel (TC and H Models only)

Parts needed for this procedure:

1	Steering wheel
1	Cover
1	Washer (5/8 inch)

Procedure

- If the cover is installed, remove the it from the hub of the steering wheel (Figure 3).
- Remove the nut from the steering shaft (Figure 3).
- Slide the steering wheel and washer onto the steering shaft (Figure 3).

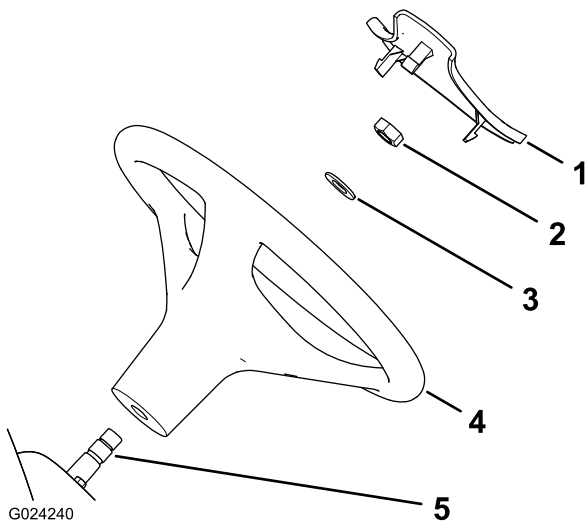

Figure 3

- | | |
|----------------------|-------------------|
| 1. Cover | 4. Steering wheel |
| 2. Nut | 5. Steering shaft |
| 3. Washer (5/8 inch) | |

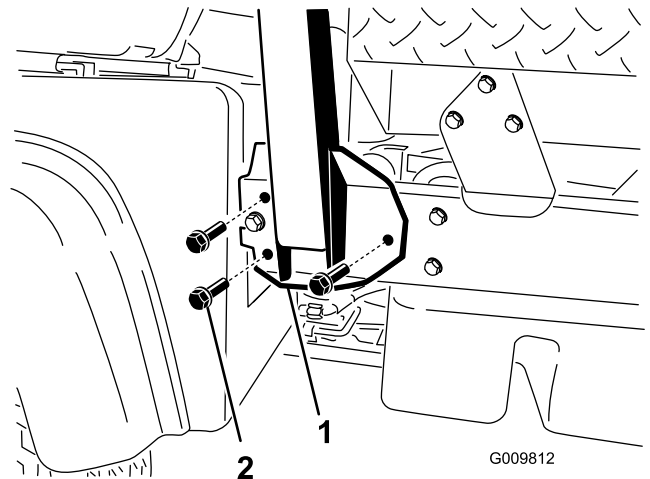

Figure 4

1. ROPS mounting bracket 2. Flange-head bolt
3. Secure each side of the ROPS mounting bracket to frame of the machine with 3 flange-head bolt (1/2 x 1-1/4 inch).
4. Torque the flange-head bolts to 115 N-m (85 ft-lb).

2

Installing the ROPS

Parts needed for this procedure:

1	ROPS frame
6	Flange-head bolt (1/2 x 1-1/4 inch)

Procedure

1. Apply medium-grade (service-removable) thread locking compound to the threads of the 6 flange-head bolts (1/2 x 1-1/4 inch).
2. Align each side of the ROPS with the mounting holes on each side of frame of the machine as shown in [Figure 4](#).

3

Connecting the Battery (TC and H Models only)

No Parts Required

Procedure

⚠ WARNING

Incorrect battery cable routing could damage the machine and cables causing sparks. Sparks can cause the battery gasses to explode, resulting in personal injury.

- Always disconnect the negative (black) battery cable before disconnecting the positive (red) cable.
 - Always connect the positive (red) battery cable first.
1. Squeeze the battery cover to release the tabs from the battery base ([Figure 5](#)).

4

Connecting the CVT Intake Duct (TC and H Models only)

No Parts Required

Procedure

Important: Remove the plastic bag covering the end of the CVT duct before starting the engine of the machine.

The CVT kit 121-9853 and adapter kit 127-8750 is required for this procedure.

1. Loosen the hose clamp securing the plastic bag at the end of the CVT intake hose and remove the bag.

Note: Discard plastic bag.

2. Raise the cargo box by performing the following:
 - A. Set the parking brake; refer to [Parking Brake \(page 16\)](#).
 - B. Start the engine; refer to [Starting the Engine \(page 27\)](#).
 - C. Move the hydraulic-lift lever backward to raise the cargo box; refer to [Hydraulic Lift Lever \(page 16\)](#).
 - D. Shut off the engine; refer to [Stopping the Engine \(page 27\)](#).
 - E. Remove the bed support from the storage brackets on back of the ROPS panel and install the support onto the cylinder rod of the bed lift cylinder; refer to [Using the Bed Safety Support \(page 36\)](#).
3. Align the CVT intake hose onto the intake-tube connector at the back side of the ROPS panel and tighten the hose clamp ([Figure 7](#)).

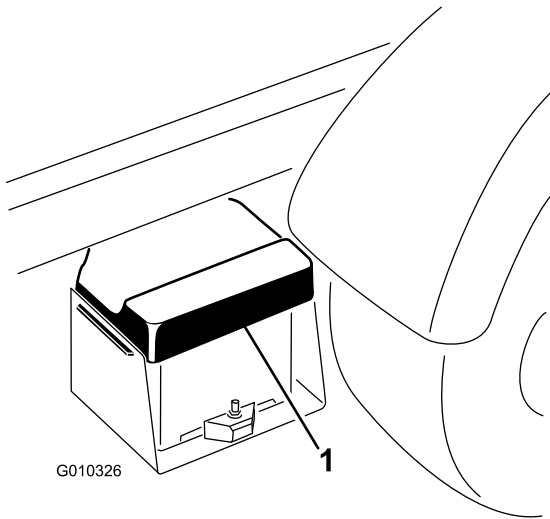

Figure 5

1. Battery cover

2. Remove the battery cover from the battery base ([Figure 5](#)).
3. Install the positive-battery cable (red) onto the positive (+) terminal of the battery and secure the cable with the bolts and nuts ([Figure 6](#)).

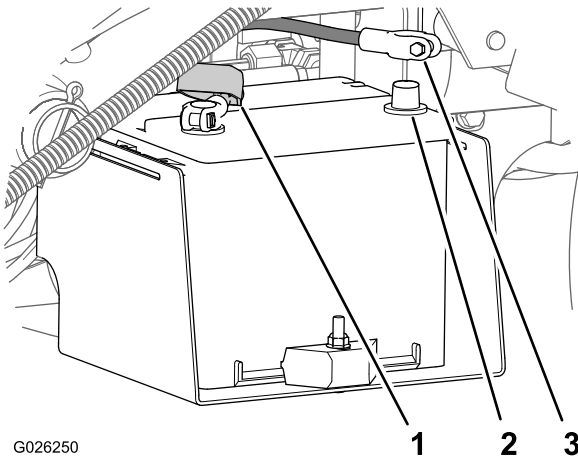

Figure 6

1. Insulator boot (positive-battery cable)
2. Negative-battery post
3. Negative-battery cable

4. Slide the insulator boot over the positive terminal.

Note: The insulator boot is used to prevent a possible short-to-ground from occurring.

5. Install the negative-battery cable (black) onto the negative (-) terminal of the battery and secure the cable with bolts and nuts.
6. Align the battery cover to the battery base ([Figure 5](#)).
7. Squeeze the battery cover, align the tabs to the battery base, and release the battery cover ([Figure 5](#)).

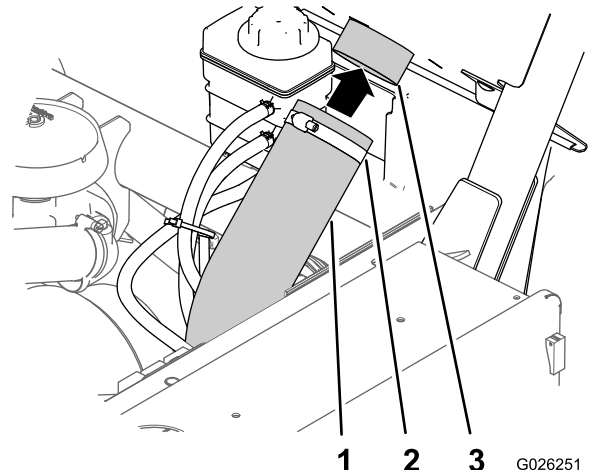

Figure 7

1. CVT intake hose
2. Hose clamp
3. Intake-tube connector

4. Remove the bed support, lower the bed, shut off the engine, and remove the key from the ignition switch.

5

Checking the Fluid Levels

No Parts Required

Procedure

1. Check the engine oil level before and after the engine is first operated; refer to [Checking the Engine-oil Level \(page 21\)](#).
2. Check the transmission-fluid level before the engine is first operated; refer to [Checking the Transmission-fluid Level \(page 47\)](#).
3. Check the engine-coolant level before the engine is first operated; refer to [\(page \)](#).
4. Check the brake fluid level before the engine is first operated; refer to [Checking the Brake Fluid \(page 24\)](#).

Product Overview

Controls

Note: Determine the left and right sides of the machine from the normal operating position.

Accelerator Pedal

The accelerator pedal ([Figure 8](#)) gives the operator the ability to vary the engine and ground speed of the vehicle when the transmission is in gear. Pressing the pedal increases the engine speed and ground speed. Releasing the pedal decreases the engine speed and ground speed of the machine.

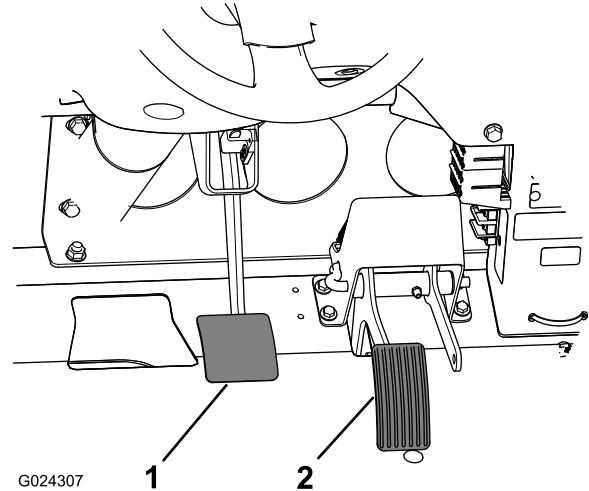

Figure 8

1. Brake pedal
2. Accelerator pedal

Brake Pedal

Use the brake pedal ([Figure 8](#)) to apply the service brakes to stop or slow the machine.

CAUTION

Brakes that are worn or not correctly adjusted may result in personal injury. If the brake pedal travels to within 3.8 cm (1-1/2 inches) of the machine floor board, adjust or repair the brakes.

Transmission Lever

Use the transmission lever ([Figure 9](#)) to shift the transmission between **P** (park), **R** (reverse), **N** (neutral), **L** (low forward), and **D** (drive) ground operation.

Important: Do not shift the transmission to the Reverse, Low, or Drive gear unless the vehicle is standing still and the engine is at low idle. Otherwise you may damage the transmission.

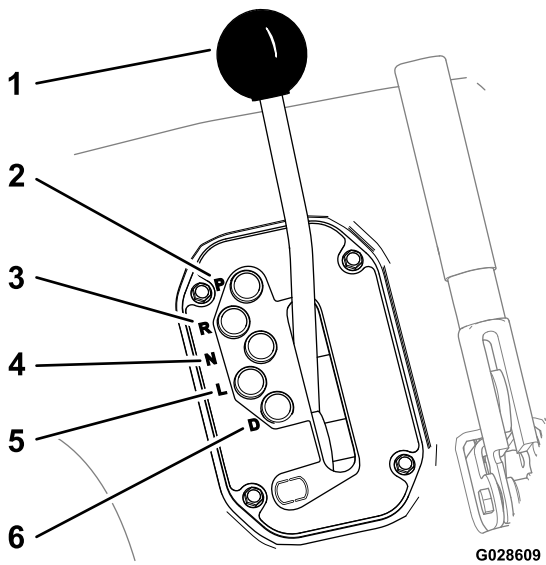

Figure 9

- | | |
|-----------------------|--------------------|
| 1. Transmission lever | 4. N (neutral) |
| 2. P (park) | 5. L (low forward) |
| 3. R (reverse) | 6. D (drive) |

Parking Brake

Whenever the engine is shut off, set the parking brake (Figure 10) to prevent accidental movement of the vehicle.

- To set the parking brake, pull back on the parking-brake lever.
- To release the parking brake, push the lever forward.

Note: Release the parking brake before moving the vehicle.

- If you park the vehicle on a steep uphill or downhill grade, shift the transmission into **P** (park) and set the parking brake. Place chocks at the downhill side of the wheels.

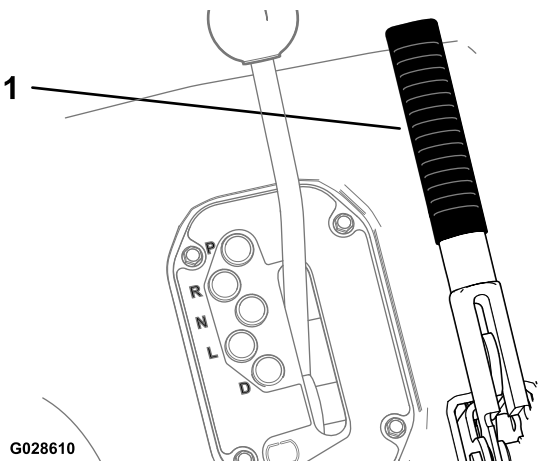

Figure 10

1. Parking-brake lever

Hydraulic Lift Lever

The hydraulic lift raises and lowers the bed. Move the hydraulic lift lever rearward to raise the bed, and forward to lower it (Figure 11).

Important: When lowering the bed, hold the lever in the forward position for 1 or 2 seconds after the bed contacts the frame to secure it in the lowered position. Do not hold the hydraulic lift in either the raise or lower position for more than 5 seconds once the cylinders have reached the end of their travel.

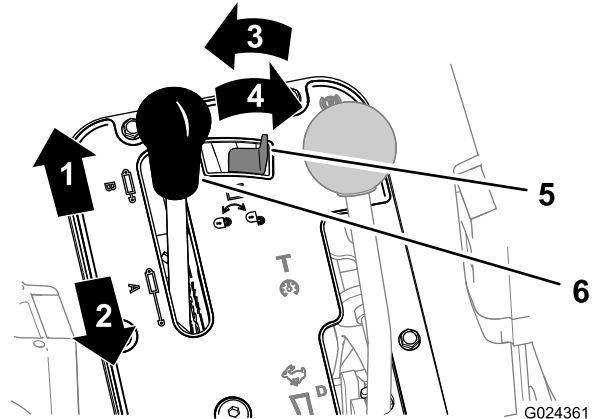

Figure 11

- | | |
|------------------|-------------------------|
| 1. Lower the bed | 4. Unlocked |
| 2. Raise the bed | 5. Hydraulic-lift lock |
| 3. Locked | 6. Hydraulic-lift lever |

Hydraulic-lift Lock

The hydraulic-lift lock locks the lift lever so that the hydraulic cylinders do not operate when the vehicle is not equipped with a bed (Figure 11). It also locks the lift lever in the On position when using the hydraulics for attachments.

Speed-range Lever

Use the speed-range lever (Figure 12) to select 1 of the 4 work-speed ranges for precise control of the maximum-ground speed or a transport-speed range that is for moving the machine between job sites.

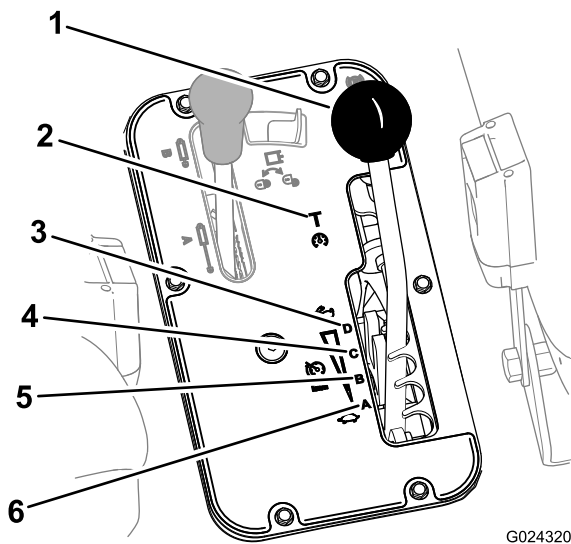

Figure 12

G024320

- | | |
|------------------------|-----------------------|
| 1. Speed-range lever | 4. C (mid-high range) |
| 2. T (transport range) | 5. B (mid-low range) |
| 3. D (high range) | 6. A (low range) |

Dashboard Switches

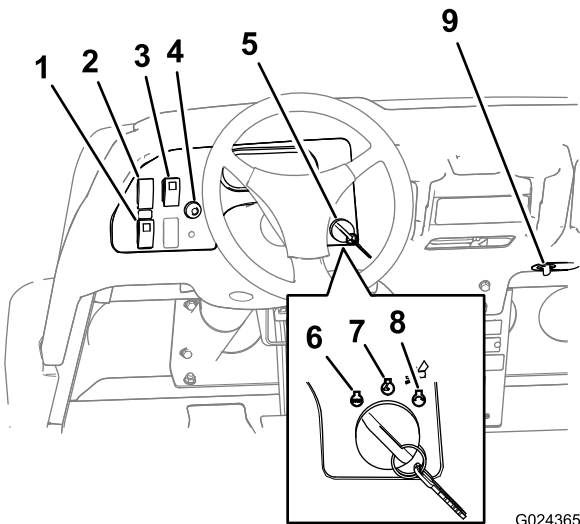

Figure 13

G024365

- | | |
|---|----------------|
| 1. High flow hydraulics switch (TC models only) | 6. Off |
| 2. Light switch | 7. On |
| 3. Differential switch | 8. Start |
| 4. Horn button (TC models only) | 9. Power point |
| 5. Ignition switch | |

High Flow Hydraulics Switch (TC models only)

Push the switch down to start the high flow hydraulics and push the switch up to shut off the hydraulics (Figure 13).

Note: You must set the high flow hydraulics switch to the Off position in order to start the engine.

Light Switch

Push the light switch down to toggle the headlights on or push the light switch up to toggle the headlights off (Figure 13).

Differential-lock Switch

The differential-lock switch allows you to lock the rear axle for increased traction. Push the differential-lock switch (Figure 13) to toggle the differential lock on or off.

Note: You may lock and unlock the differential while the vehicle is in motion.

Horn Button (TC models only)

Pressing the horn button activates the horn (Figure 13).

Ignition Switch

Use the ignition switch (Figure 13) to start and stop the engine. It has 3 positions: Off, Run, and Start. Rotate the key clockwise to the Start position to engage the starter motor. Release the key when the engine starts. The key will move automatically to the On position. To shut the engine off, rotate the key counterclockwise to the Off position.

Power Point

Use the power point socket (Figure 13) to power optional 12-volt electrical accessories.

Instrument Cluster

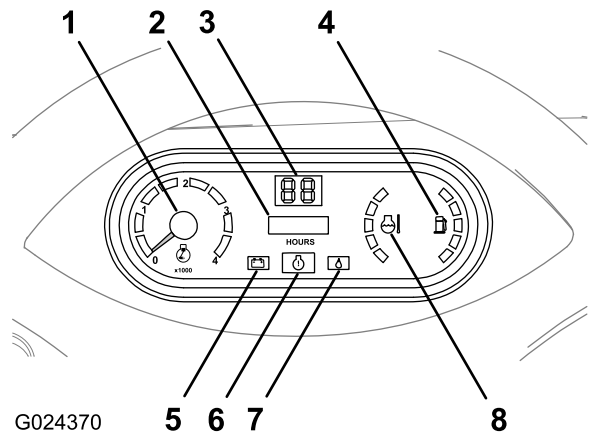

Figure 14

G024370

- | | |
|----------------|------------------------------|
| 1. Tachometer | 5. Charge-indicator light |
| 2. Hour meter | 6. Check-engine light |
| 3. Speedometer | 7. Low-oil pressure light |
| 4. Fuel gauge | 8. Coolant-temperature gauge |

Tachometer

The tachometer displays the speed of the engine (Figure 14).

Note: The white triangle indicates the desired engine speed for 540 rpm PTO operation.

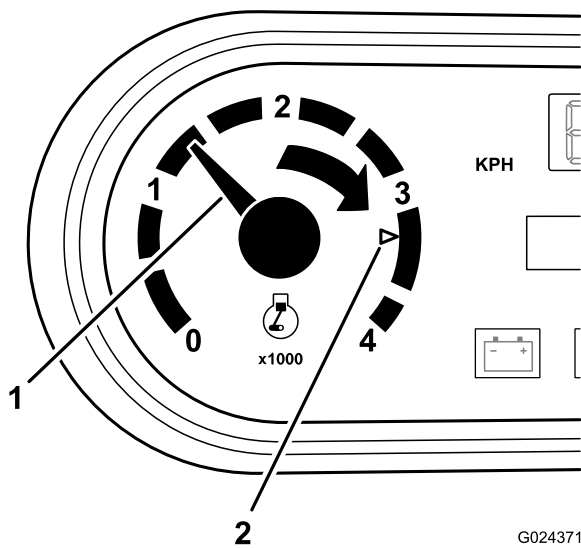

Figure 15

G024371

1. Engine speed (in rpm)
2. 3300 rpm for 540 rpm PTO operation

Hour Meter

The hour meter indicates the total hours of machine operation. The hour meter (Figure 14) starts to function whenever the key switch is rotated to the On position or if the engine is running.

Speedometer

The speedometer registers the ground speed of the vehicle (Figure 14). The speedometer is in mph, but you can easily converted the speedometer to km/h. Refer to [Converting the Speedometer](#) (page 54).

Check Engine Light

The check engine light (Figure 14) will illuminate to notify operator of a engine malfunction.

Contact your authorized Toro service dealer.

Oil Pressure Warning Light

The oil pressure warning light illuminates (Figure 14) if the engine oil pressure drops below a safe level while the engine is running.

Important: If the light flickers or remains on, stop the vehicle, turn off the engine, and check the oil level. If the oil level was low, but adding oil does not cause the light to go out when the engine is started, turn the engine off immediately and contact your Authorized Service Distributor for assistance.

Coolant Temperature Gauge and Light

The coolant temperature gauge displays the coolant temperature of the engine. The light operates only when the ignition switch is in On position (Figure 14). The coolant

temperature light will illuminate red and flash if the engine overheats.

Fuel Gauge

The fuel gauge shows the amount of fuel in the tank. It displays only when ignition switch is in the On position (Figure 14). The red segment of the display indicates low fuel level and the flashing-red light indicates that the fuel in the tank is near empty.

Passenger Hand Hold

The passenger hand hold is located on the dashboard (Figure 16).

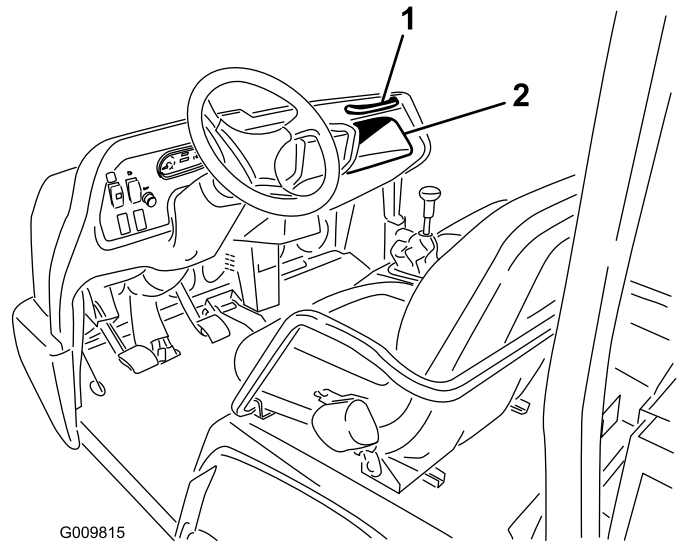

G009815

Figure 16

1. Passenger hand hold
2. Storage compartment

Seat Adjusting Lever

Use the seat adjustment lever to adjust the seat forward or backward for operator comfort (Figure 17).

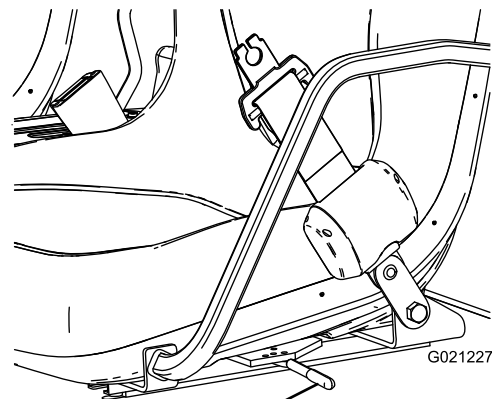

G021227

Figure 17

1. Seat-adjusting lever

Specifications

Note: Specifications and design are subject to change without notice.

Dimensions

Overall Width	160 cm (63 inches)
Overall Length	without bed—326 cm (128 inches); with full bed—331 cm (130 inches); with 2/3 bed in rear mounting location—346 cm (136 inches)
Base Weight (Dry)	Model 07390—866 kg (1905 lb); Model 07390H—866 kg (1905 lb); Model 07390TC—887 kg (1951 lb)
Rated Capacity (includes 91 kg (200 lb) operator, 91 kg (200 lb) passenger and loaded attachment)	Model 07390—1498 kg (3295 lb); Model 07390TC—1477 kg (3249 lb); Model 07090H—1498 kg (3298 lb)
Maximum Gross Vehicle Weight	2363 kg (5210 lb)
Tow Capacity	Tongue weight: 272 kg (600 lb); Maximum trailer weight: 1587 kg (3,500 lb)
Ground Clearance	18 cm (7 inches) with no load
Wheel Base	118 cm (70 inches)
Wheel Tread (center line to center line)	Front: 117 cm (46 inches); Rear: 121 cm (48 inches)
Height	191 cm (75 inches) to top of ROPS

Attachments/Accessories

A selection of Toro approved attachments and accessories is available for use with the machine to enhance and expand its capabilities. Contact your Authorized Service Dealer or Distributor or go to www.Toro.com for a list of all approved attachments and accessories.

Operation

Note: Determine the left and right sides of the machine from the normal operating position.

⚠ CAUTION

You may be injured or killed if the raised bed of the machine falls on you.

Before working under a raised bed, remove any cargo and position the safety support on the fully extended cylinder rod.

Operating the Cargo Box

Raising the Cargo Box

⚠ WARNING

Driving the vehicle with the cargo box raised may cause the vehicle to tip or roll easier. The box structure may become damaged if you operate the vehicle with the box raised.

- Only operate the vehicle when the cargo box is down.
- After dumping a load, lower the cargo box.

⚠ CAUTION

If a load is concentrated near the back of the cargo box when you release the latches, the tailgate may unexpectedly tip open, injuring you or bystanders.

- Center the load in the cargo box, if possible.
- Ensure that no one is leaning over the box or standing behind it when releasing the tailgate latches.
- Remove all cargo from the box before lifting the box up to service the machine.
 1. Set the parking brake; refer to [Parking Brake \(page 16\)](#).
 2. Start the engine; refer to [Starting the Engine \(page 27\)](#).
 3. Move the lever backward to raise the cargo box to the desired position. ([Figure 18](#)).

Note: If you are maintaining the machine and need to have the box raised, secure the box with the bed safety support; refer to [Using the Bed Safety Support \(page 36\)](#).

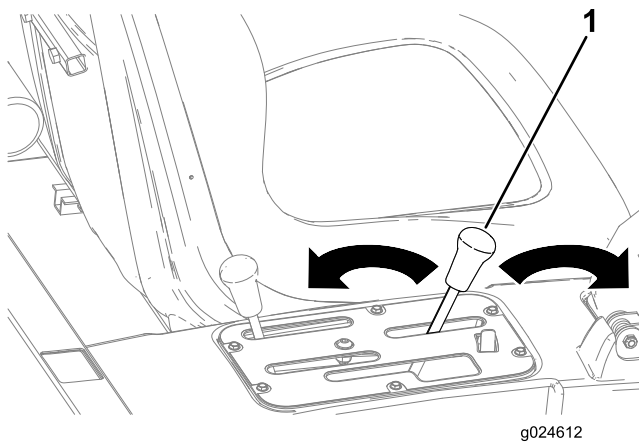

Figure 18

1. Cargo-box lever

Lowering the Box

⚠ WARNING

The weight of the box may be heavy. Hands or other body parts could be crushed.

Keep hands and other body parts clear when lowering the box.

1. Ensure that the parking brake is set; refer to [Parking Brake \(page 16\)](#).
2. If the bed support is installed, remove the it; refer to [Using the Bed Safety Support \(page 36\)](#).
3. Start the engine; refer to [Starting the Engine \(page 27\)](#).
4. Move the lever forward to lower the cargo box ([Figure 18](#)).

Opening the Tailgate

1. Ensure that the cargo box is down and latched.
2. Open the latches on the left and right side of the cargo box ([Figure 19](#)) and lower the tailgate.

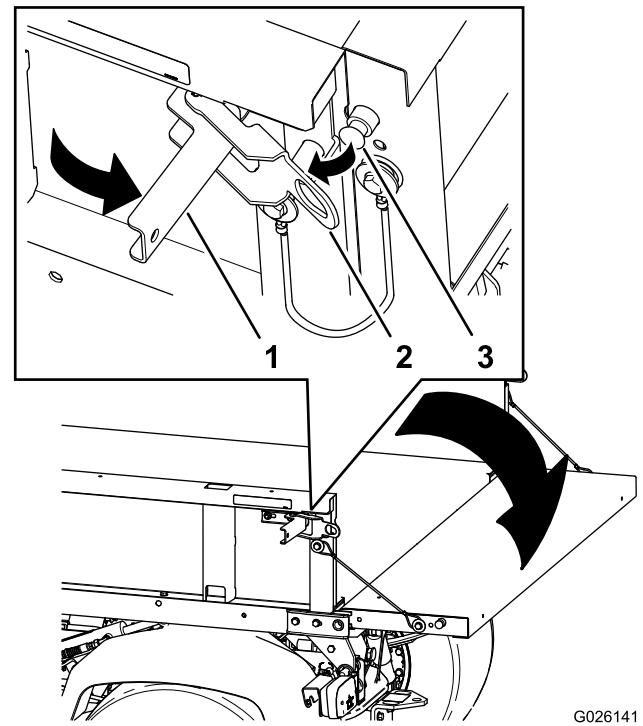

Figure 19

1. Latch handle
2. Latch gate
3. Latch pin

Checking the Fluid Levels

Preparing to Check the Fluid Levels

1. Move the machine to a level surface.
2. Shift the transmission to the Park position, shut off the engine, set the parking brake, and remove the key from the ignition switch.
3. Allow the machine to cool before you check the fluid levels of the machine.
4. Check the following:

Note: Checking the engine oil, hydraulic fluid level, or coolant level requires raising and lowering the cargo box of the machine; refer to [Operating the Cargo Box \(page 19\)](#).

- [Checking the Engine-oil Level \(page 21\)](#)
- [Checking the Hydraulic Fluid \(page 22\)](#)
- (page)
- [Checking the Brake Fluid \(page 24\)](#)

Checking the Hydraulic Fluid

Service Interval: Before each use or daily (Check the level of hydraulic fluid before the engine is first started and daily thereafter.)

Hydraulic Fluid Type: Mobil M15

Hydraulic Fluid Capacity: (Non-TC model): 7.5 l (2 US gallons)

Hydraulic Fluid Capacity: (Non-TC model with the High Flow Hydraulic Kit (option) or TC Model): 15.1 l (4 US gallons)

⚠ WARNING

Hydraulic fluid escaping under pressure can penetrate skin and cause injury.

- Make sure that all hydraulic fluid hoses and lines are in good condition and all hydraulic connections and fittings are tight before applying pressure to the hydraulic system.
- Keep your body and hands away from pinhole leaks or nozzles that eject high pressure hydraulic fluid.
- Use cardboard or paper to find hydraulic leaks.
- Safely relieve all pressure in the hydraulic system before performing any work on the hydraulic system.
- Seek immediate medical attention if fluid is injected into your skin.

1. Clean the area around the filler neck and the cap of the hydraulic reservoir (Figure 23 and Figure 24).

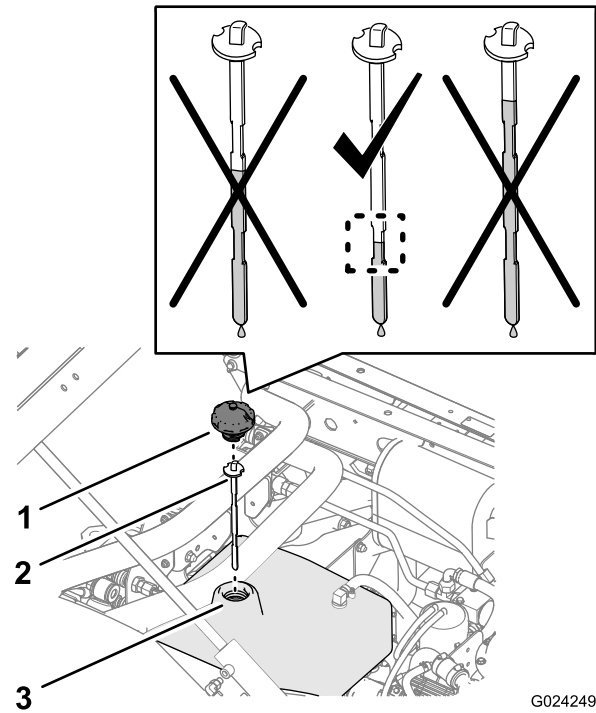

Figure 23
Hydraulic Fluid Level (Non-TC models)

1. Cap
2. Dipstick
3. Filler neck

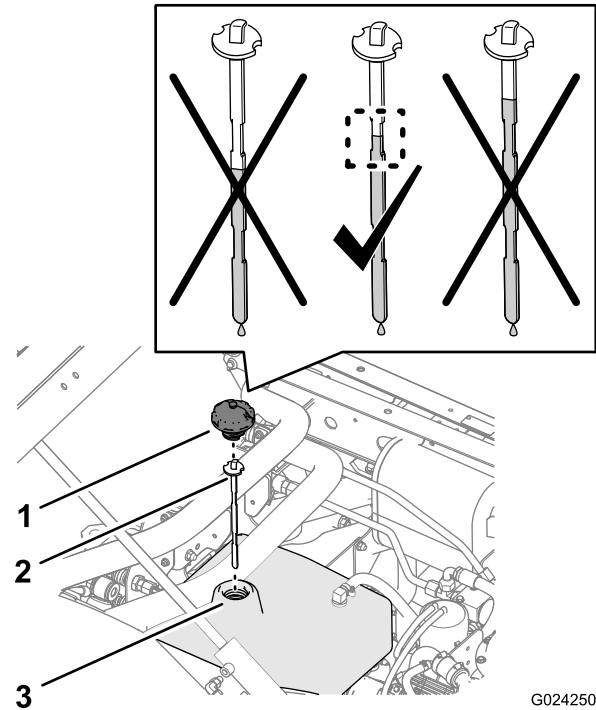

Figure 24
Hydraulic Fluid Level (Non-TC model with the High Flow Hydraulic Kit (option) or TC model)

1. Cap
2. Dipstick
3. Filler neck

2. Remove the cap and dipstick from the filler neck of the reservoir and wipe the dipstick clean with a rag (Figure 23 and Figure 24).
3. Insert the dipstick into the filler neck; then remove it and check the fluid level (Figure 23 and Figure 24).
 - **Non-TC model:** the fluid level should be between the lower indented area on the dipstick.
 - **Non-TC model with the High Flow Hydraulic Kit (option) or TC model:** the fluid level should be between the upper indented area on the dipstick.
4. If the level is low, add the specified hydraulic fluid into the reservoir to raise the level to the middle of the indented area on the dipstick (Figure 23 and Figure 24).
5. Install the dipstick and cap to the filler neck of the reservoir (Figure 23 and Figure 24).

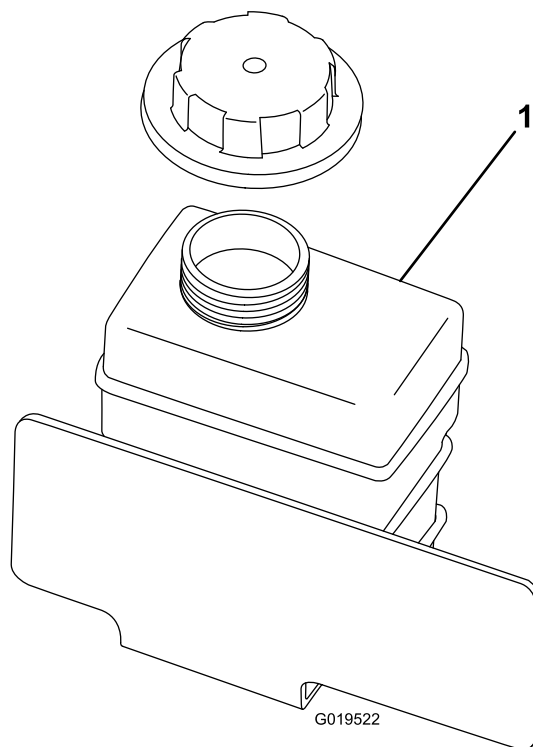

Figure 25

Checking the Coolant Level

Service Interval: Before each use or daily Check the Coolant level at the overflow reservoir only. Do Not remove the radiator cap. (Check the coolant level before the engine is first started and daily thereafter.)

Coolant type: a 50/50 solution of water and permanent ethylene glycol antifreeze

1. Park the machine on a level surface.

⚠ CAUTION

If the engine has been running, the pressurized, hot coolant can escape and cause burns.

- **Do not open the radiator cap.**
 - **Allow the engine to cool at least 15 minutes or until the radiator cap is cool enough to touch without burning your hand.**
 - **Use a rag when opening the reserve tank cap, and open the cap slowly to allow steam to escape.**
 - **Do not check the coolant level at the radiator; check the coolant level only at the reserve tank.**
2. Check the coolant level at the reserve tank (Figure 25).

Note: The coolant should be up to the bottom of the filler neck.

1. Coolant reserve tank

3. If coolant is low, remove the reserve tank cap and add a 50/50 mixture of water and permanent ethylene-glycol antifreeze.

Note: Do not overfill.

4. Install the reserve-tank cap.

Checking the Brake Fluid

Service Interval: Before each use or daily—Check the brake fluid level. (Check the level before the engine is first started and daily thereafter.)

Every 1,000 hours/Every 2 years (whichever comes first)—Change the brake fluid.

Brake fluid type: DOT 3 brake fluid

Note: The brake-fluid reservoir is shipped from the factory filled with DOT 3 brake fluid.

The brake-fluid reservoir is located under the hood and below the dash.

1. Park the machine on a level surface.
2. Remove the hood; refer to [Removing the Hood \(page 38\)](#).
3. Check the fluid level in the brake-fluid reservoir ([Figure 26](#) and [Figure 27](#)).

Note: The fluid level should be up to the Full line on the reservoir.

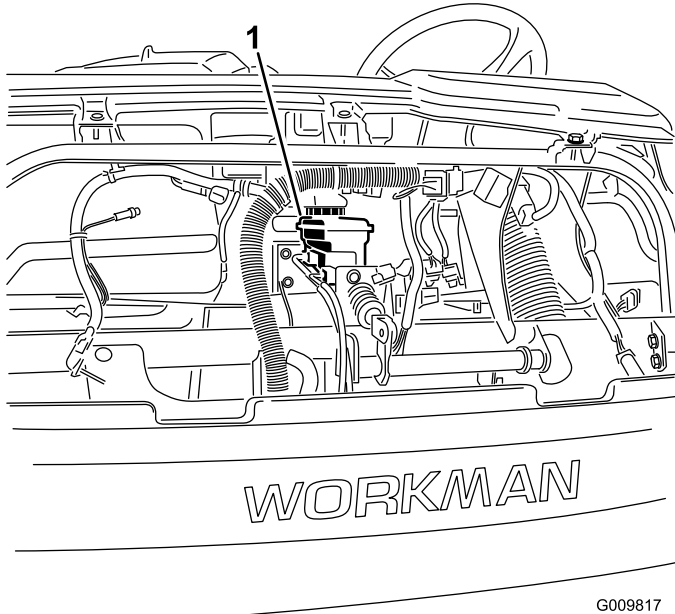

Figure 26

1. Brake-fluid reservoir

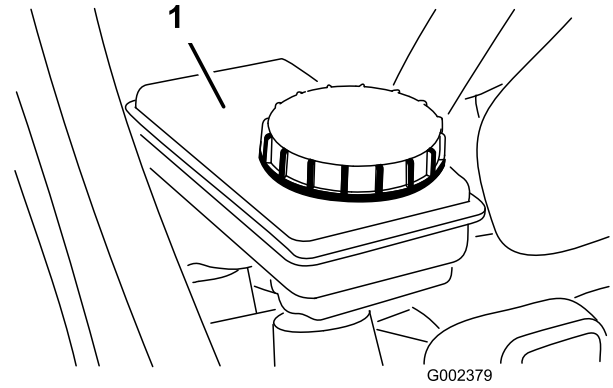

Figure 27

1. Brake-fluid reservoir

4. If the fluid level is low, perform the following:
 - A. Clean the area around the cap for the reservoir ([Figure 27](#)).
 - B. Remove the reservoir cap ([Figure 27](#)).
 - C. Add the specified brake fluid to the Full line on the reservoir ([Figure 27](#)).

Note: Do not overfill the brake-fluid reservoir.

 - D. Install the cap ([Figure 27](#)).
5. Install the hood; refer to [Removing the Hood \(page 38\)](#).

Checking the Oil Pressure Warning Light

Service Interval: Before each use or daily

Note: If you just stopped the engine, it may take 1 to 2 minutes for the light to come on.

1. Apply the parking brake.
2. Turn the ignition key to the On position, but do not start the engine.

Note: The oil pressure light should glow red.

Note: If the light does not function, either a bulb is burned out or there is a malfunction in the system which must be repaired.

Adding Fuel

Fuel tank capacity: 25 L (6.5 US gallons).

- For best results, use only clean, fresh (less than 30 days old), unleaded gasoline with an octane rating of 87 or higher ((R+M)/2 rating method).
- **ETHANOL:** Gasoline with up to 10% ethanol (gasohol) or 15% MTBE (methyl tertiary butyl ether) by volume is acceptable. Ethanol and MTBE are not the same. Gasoline with 15% ethanol (E15) by volume is not approved for use. Never use gasoline that contains more than 10% ethanol by volume, such as E15 (contains 15% ethanol), E20 (contains 20% ethanol), or E85 (contains up to 85% ethanol). Using unapproved gasoline may cause performance problems and/or engine damage which may not be covered under warranty.
- **Do not** use gasoline containing methanol.
- **Do not** store fuel either in the fuel tank or fuel containers over the winter unless a fuel stabilizer is used.
- **Do not** add oil to gasoline.

⚠ DANGER

In certain conditions, gasoline is extremely flammable and highly explosive. A fire or explosion from gasoline can burn you and others and can damage property.

- **Before removing the fuel tank cap, make sure that the vehicle is positioned on a level surface. Open the fuel tank cap slowly.**
- **Fill the fuel tank outdoors, in an open area, when the engine is cold. Wipe up any gasoline that spills.**
- **Never fill the fuel tank inside an enclosed trailer.**
- **Do not fill the fuel tank completely full. Add gasoline to the fuel tank until the level is 25 mm (1 inch) below the bottom of the filler neck. This empty space in the tank allows the gasoline to expand.**
- **Never smoke when handling gasoline, and stay away from an open flame or where gasoline fumes may be ignited by a spark.**
- **Store gasoline in an approved container and keep it out of the reach of children. Never buy more than a 30-day supply of gasoline.**
- **Do not operate the machine without the entire exhaust system in place and in proper working condition.**

⚠ DANGER

In certain conditions during fueling, static electricity can be released, causing a spark, which can ignite the gasoline vapors. A fire or explosion from gasoline can burn you and others and can damage property.

- **Always place gasoline containers on the ground away from your vehicle before filling.**
- **Do not fill gasoline containers inside a vehicle or on a truck or trailer bed, because interior carpets or plastic truck bed liners may insulate the container and slow the loss of any static charge.**
- **When practical, remove gas-powered equipment from the truck or trailer and refuel the equipment with its wheels on the ground.**
- **If this is not possible, then refuel such equipment on a truck or trailer from a portable container, rather than from a gasoline dispenser nozzle.**
- **If you must use a gasoline dispenser nozzle,, keep the nozzle in contact with the rim of the fuel tank or container opening at all times until fueling is complete.**

1. Clean the area around the fuel-tank cap (Figure 28).
2. Remove the fuel-tank cap (Figure 28).

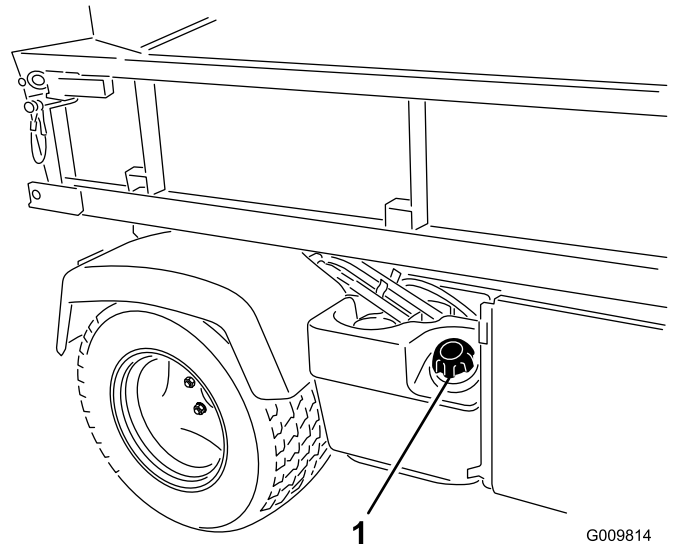

Figure 28

1. Fuel-tank cap
 3. Fill the tank to about 1 inch below the top of the tank, (bottom of the filler neck), then install the cap.
- Note:** Do not overfill the fuel tank with fuel.
4. Wipe up any fuel that may have spilled to prevent a fire hazard.

Checking the Tire Pressure

Service Interval: Before each use or daily

The maximum air pressure in the front tires is 220 kPa (32 psi) and the rear tires is 124 kPa (18 psi).

Check the tire pressure frequently to ensure proper inflation. If the tires are not inflated to the correct pressure, the tread will wear prematurely.

Figure 29 shows an example of tire wear caused by under inflation.

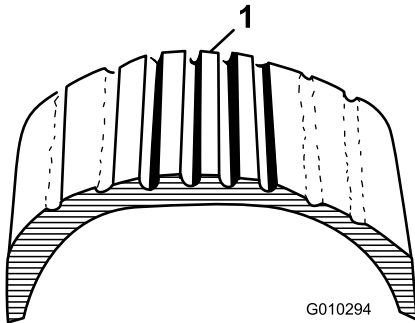

Figure 29

1. Under-inflated tire

Figure 30 shows an example of tire wear caused by over inflation.

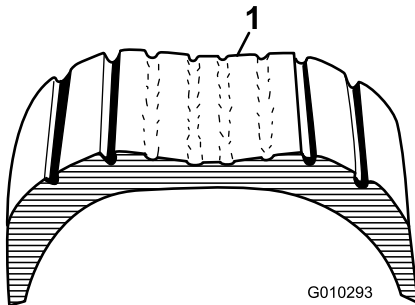

Figure 30

1. Over-inflated tire

Removing Debris from the Cooling System

Service Interval: Before each use or daily (Clean it more frequently in dirty conditions.)

1. Shut off the engine.
2. Clean the engine area thoroughly of all debris.
3. Unlatch and remove the radiator screen from the front of the radiator (Figure 31).

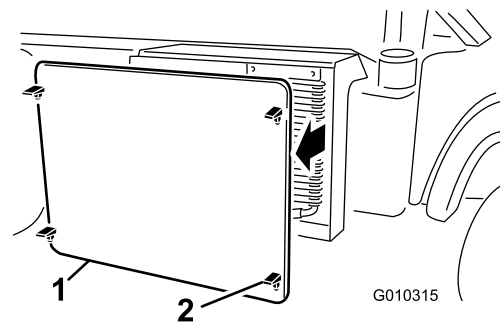

Figure 31

1. Radiator screen
2. Latch

4. If so equipped, rotate the latches and pivot the oil cooler away from the radiator (Figure 32).

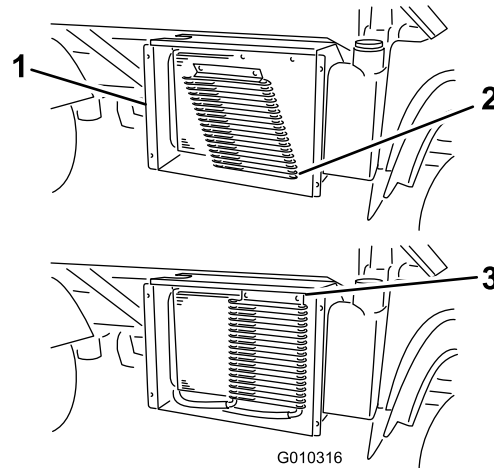

Figure 32

1. Radiator housing
2. Oil cooler
3. Latches

5. Clean the radiator, oil cooler, and screen thoroughly with compressed air.

Note: Blow debris away from the radiator.

6. Install the cooler and screen to the radiator.

Performing Pre-start Checks

Safe operation begins before taking the vehicle out for a day's work. You should check these items each time:

- Check the tire pressure.

Note: These tires are different than car tires, they require less pressure to minimize turf compaction and damage.

- Check all fluid levels and add the appropriate amount of Toro specified fluids, if any are found to be low.
- Check the front of the radiator. Remove any debris and clean the radiator screen.
- Check the brake pedal operation.
- Check the oil pressure warning light.
- Check to see that the lights are working.

- Turn the steering wheel to the left and right to check the steering response.
- Stop the engine and wait for moving parts to stop, then check for oil leaks, loose parts, and any other noticeable malfunctions.

If any of the above items are not correct, notify your mechanic or check with your supervisor before taking the vehicle out for the day. Your supervisor may want you to check other items on a daily basis, so ask what your responsibilities are.

Starting the Engine

Important: Do not attempt to push or tow vehicle to get it started. Damage to the drive train could result.

Note: Refer to (page).

1. Sit on the operator seat and engage the parking brake.
2. Disengage the PTO and high flow hydraulics (if so equipped) and move the hand throttle lever to the Off position (if so equipped).
3. Move the transmission lever to the **P** (park) position.
4. Ensure that the hydraulic-lift lever is in the Off position (center).
5. Press the brake pedal.

Note: Keep your foot off the accelerator pedal.

6. Insert key into ignition switch and rotate it clockwise to start the engine.

Note: Release key when engine starts.

Note: The engine oil pressure warning light should turn off.

Important: To prevent overheating of the starter motor, do not engage starter longer than 15 seconds. After 15 seconds of continuous cranking, wait 60 seconds before engaging starter motor again.

Driving the Vehicle

Note: Refer to (page).

1. Press the brake pedal.
2. Release the parking brake.
3. Move the transmission lever to the desired gear.
4. Release the service brake and gradually press in the accelerator pedal.

Important: Always stop the vehicle before shifting to reverse a forward gear or to a forward gear from reverse.

Use the chart below to determine the ground speed of each gear when operating the machine with the speed-range control in the **T** (transport) position.

Gear	Speed (kmh)	Speed (mph)
R (reverse)	0 to 21	0 to 13
L (low forward)	0 to 18	0 to 11
D (Drive)	0 to 32	0 to 20

Note: Avoid long periods of engine idling.

Note: Leaving ignition switch in the On position for long periods of time without running the engine will discharge the battery.

Stopping the Vehicle

Note: Refer to (page).

To stop the vehicle, remove your foot from the accelerator pedal, then press the brake pedal.

Stopping the Engine

Note: Refer to (page).

1. Ensure that the machine is stopped.
2. Move the transmission lever to the **P** (Park) position.
3. Set the parking brake.
4. Rotate the ignition key to the Off position and remove the key from the switch.

Using the Speed-range Control

Use the lever of the speed-range control to limit the maximum ground speed of the machine for operations that require a constant speed like spraying and top dressing. The speed-range lever (Figure 33) is used to select 1 of the 4 work-speed ranges that are used to limit maximum ground speed or a transport-speed range that is used when you move the machine between job sites.

Note: You must release the accelerator pedal in order to shift between speed ranges, but you do not need to stop the machine in order to shift.

- Move the speed-range lever into the detent for speed ranges A, B, C, and D when precise control of maximum-ground speed is desired.
- Move the speed-range lever to transport position by moving the speed-range lever out of the detent for range A, B, C, or D, then forward to the **T** position.

Note: Use the speed-range control to limit the maximum-ground speed in each range by 4 to 18 kmh (2.5 to 11 mph) with the transmission lever in the **L** low (forward) position or 8 to 32 kmh (5 to 20 mph) with the transmission lever in the in the **D** drive position.

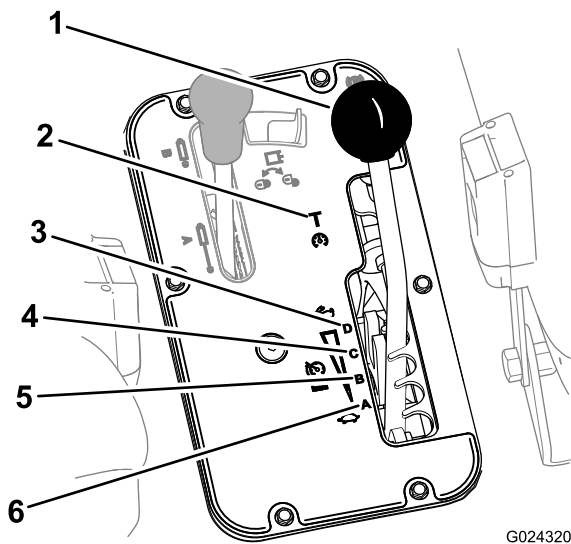

Figure 33

- | | |
|------------------------|-----------------------|
| 1. Speed-range lever | 4. C (mid-high range) |
| 2. T (transport range) | 5. B (mid-low range) |
| 3. D (high range) | 6. A (low range) |

Using the Differential Lock

⚠ WARNING

Tipping or rolling the vehicle on a hill can cause a serious injury.

- The extra traction available with the differential lock can be enough to get you into dangerous situations such as climbing slopes that are too steep to turn around. **Be extra careful when operating with the differential lock on, especially on steeper slopes.**
- **If the differential lock is on when making a sharp turn at a higher speed and the inside rear wheel lifts off the ground, there may be a loss of control which could cause vehicle to skid. Use the differential lock only at slower speeds.**

⚠ CAUTION

Turning with the differential lock on can result in loss of vehicle control. Do not operate with differential lock on when making sharp turns or at high speeds.

The differential lock increases the traction of the vehicle by locking the rear wheels so that 1 wheel will not spin out. This can help when you have heavy loads to haul on wet turf or slippery areas, going up hills, and on sandy surfaces. It is important to remember that this extra traction is only for temporary limited use. Its use does not replace the safe operation already discussed concerning steep hills and heavy loads.

The differential lock causes the rear wheels to spin at the same speed. When using differential lock your ability to make sharp turns is somewhat restricted and may scuff the turf. Use the differential lock only when needed and at slower speeds.

Note: Vehicle motion plus a slight turn is required to engage or disengage differential lock.

- Press the differential-lock switch up to lock the differential (Figure 34).

Note: The light in the differential-lock switch will illuminate when the switch is in the lock position.

- Press the differential-lock switch up to unlock the differential (Figure 34).

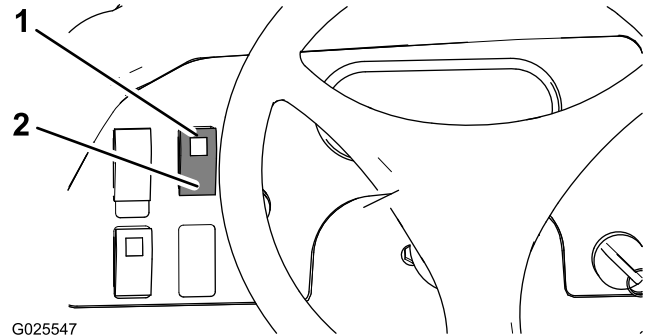

Figure 34

- | | |
|--|--|
| 1. Lock position
(differential-lock switch) | 2. Unlock position
(differential-lock switch) |
|--|--|

Breaking in a New Machine

Service Interval: After the first 100 hours

- Check the fluid and engine oil levels regularly and be alert for indications of overheating in any component of the vehicle.
- After starting a cold engine, let it warm up for about 15 seconds before shifting into gear.

Note: Allow more time to warm-up the engine when operating in cold ambient temperatures.

- Avoid racing the engine.
- To ensure optimum performance of the brake system, burnish (break-in) the brakes before use. To burnish the brakes, bring the vehicle up to full speed, apply the brakes to rapidly stop the vehicle without locking up the tires. Repeat this 10 times, waiting 1 minute between stops to avoid overheating the brakes. This is most effective if the vehicle is loaded with 454 kg (1000 lb).
- Vary vehicle speeds during operation. Avoid excessive idling. Avoid fast starts and quick stops.
- A break-in oil for the engine is not required. The original engine oil is the same type specified for regular oil changes.
- Refer to [Heavy Duty Operation \(page 35\)](#) for any special low-hour checks.

Checking the Interlock System

Service Interval: Before each use or daily

The purpose of the interlock system is to prevent the engine from cranking or starting unless the brake pedal is pressed and the hydraulic lift lever is in the Neutral position.

⚠ CAUTION

If safety interlock switches are disconnected or damaged, the machine could operate unexpectedly causing personal injury.

- Do not tamper with the interlock switches.
- Check the operation of the interlock switches daily and replace any damaged switches before operating the machine.

Note: Refer to *Attachment Operator's Manual* for procedures on checking the attachment interlock system.

Verifying the Hydraulic Lift Lever Interlock Switch

1. Sit on the operator's seat and set the parking brake.
2. Move the shift lever to the Neutral position, ensure that the hydraulic lift lever is in the center position.
3. If Non-TC model with the High Flow Hydraulic Kit (option) or TC model, set the high flow hydraulic switch to the Off position.
4. Press brake pedal.
5. Move the hydraulic lift lever forward and rotate the ignition key clockwise to the start position.

If engine cranks or starts, there is a malfunction in the interlock system that must be repaired before operating vehicle.

Verifying the Brake Pedal Interlock Switch

1. Sit on the operator's seat and set the parking brake.
2. Move the shift lever to the Neutral position, ensure that the hydraulic lift lever is in the center position.
3. If Non-TC model with the High Flow Hydraulic Kit (option) or TC model, set the high flow hydraulic switch to the Off position.
4. Rotate the ignition key clockwise to the start position.

Note: Do not press the brake pedal

If engine cranks or starts, there is a malfunction in the interlock system that must be repaired before operating vehicle.

Verifying the High Flow Switch Interlock

Non-TC model with the High Flow Hydraulic Kit (option) or TC model

1. Sit on the operator's seat and engage the parking brake.
2. Move the shift lever to the Neutral position and ensure that the hydraulic lift lever is in the center position.
3. Set the high flow hydraulic switch to the On position.
4. Press brake pedal.
5. Rotate the ignition key clockwise to the start position.

If engine cranks or starts, there is a malfunction in the interlock system that must be repaired before operating vehicle.

Transporting the Machine

For moving the machine long distances, use a trailer. Make sure that the machine is secured to the trailer. Refer to [Figure 35](#) and [Figure 36](#) for the location of the tie-down points.

Important: Trailers weighing over 680 kg (1500 lb) are required to be equipped with trailer brakes.

Note: Load the machine on the trailer with the front of the machine facing forward. If that is not possible, secure the hood of the machine to the frame with a strap or remove the hood and transport and secure it separately, otherwise the hood may blow off during transport.

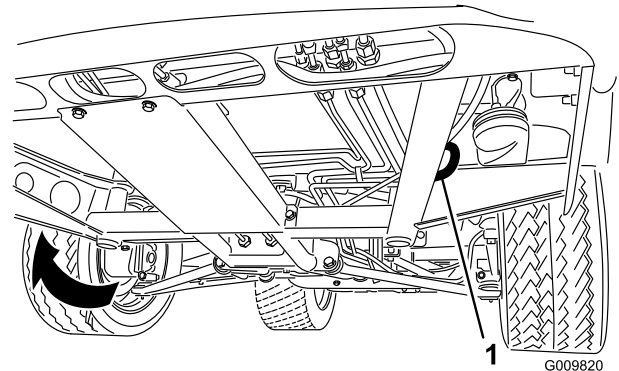

Figure 35

1. Eye hole in frame (each side)

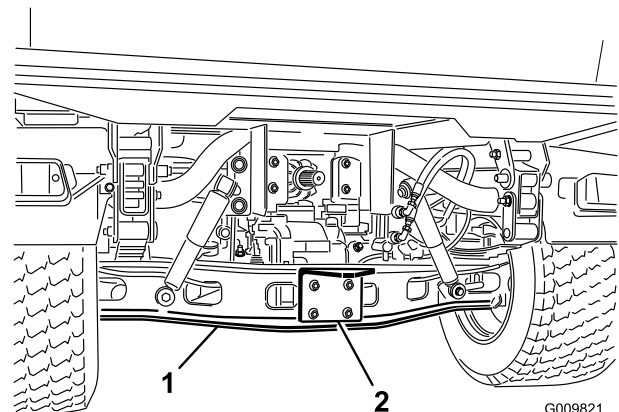

Figure 36

1. Axle
2. Hitch plate

Towing the Machine

In case of an emergency, the machine can be towed for a short distance. However, Toro does not recommend this as a standard procedure.

⚠ WARNING

Towing at excessive speeds could cause machine to lose steering control. Never tow machine faster than 8 kph (5 mph).

Towing the machine is a 2-person job. Affix a tow line to holes in the front frame member. Move the shifter to Neutral and release the parking brake. If the machine must be moved a considerable distance, transport it on a truck or trailer.

Note: The power steering will not function, making it difficult to steer.

Towing a Trailer with the Machine

This machine is capable of pulling trailers and attachments of greater weight than the machine itself.

Several types of tow hitches are available for this machine, depending on your application. Contact your Authorized Distributor for details.

When equipped with a tow hitch bolted onto the rear axle, your machine can tow trailers or attachments with a gross trailer weight (GTW) up to 1587 kg (3500 lb). Always load a trailer with 60% of the cargo weight in the front of the trailer. This places approximately 10% (272 kg (600 lb) max.) of the gross trailer weight (GTW) on the tow hitch of the machine.

Trailer brakes are required whenever you tow a trailer over 680 kg (1500 lb) GTW is towed behind this machine.

When hauling cargo or towing a trailer (attachment), do not overload your machine or trailer. Overloading can cause poor performance or damage to the brakes, axle, engine, transaxle, steering, suspension, body structure, or tires.

Important: To reduce potential for drive line damage, use low range.

When towing 5th wheel attachments, like a fairway aerator, always install the wheely bar (included with the fifth wheel kit) to prevent the front wheels from lifting off the ground if the towed attachments movement is suddenly impaired.

Using the Hydraulic Control

The hydraulic control supplies hydraulic power from the machine pump whenever the engine is running. Use the quick couplers at the rear of the machine to provide hydraulic power for rear hitch attachments.

Important: If multiple vehicles use the same attachment, cross contamination of the hydraulic fluid may occur. Change the hydraulic fluid more frequently.

Hydraulic Control Positions

- Off Position

This is the normal position for the control valve when it is not being used. In this position the work ports of the control valve are blocked and any load will be held by the check valves in both directions.

- Raise (Quick Coupler A position)

This hydraulic lift lever position lifts the bed cylinders or a rear hitch attachment by applying Raise hydraulic pressure through quick coupler A. This also allows the return oil to flow through quick coupler B, back through the control valve, and then into the reservoir. This is a momentary position; when the hydraulic lift lever is released, a spring returns the lever to the Center Off position.

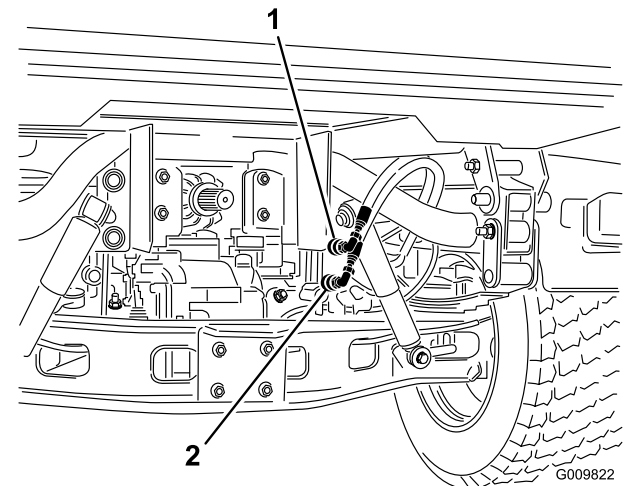

Figure 37

1. Quick coupler A position 2. Quick coupler B position

- Lower (Quick Coupler B position)

This position lowers the bed or a rear hitch attachment by applying Lower hydraulic pressure through quick coupler B. This also allows the return oil to flow through quick coupler A, back through the control valve, and then into the reservoir. This is a momentary position; when the hydraulic lift lever is released, a spring returns the control lever to the Center Off position. Momentarily holding and then releasing the hydraulic lift lever in this position will provide flow to the quick coupler B, which provides Lower hydraulic pressure to the bed cylinders or a rear hitch attachment. When the hydraulic lift lever is released, the Lower hydraulic pressure to the bed cylinders or a rear hitch attachment is hydraulically locked.

Important: If used with a hydraulic cylinder, holding the hydraulic lift lever in the Lower position

causes the oil flow to go over a relief valve, which can damage the hydraulic system.

- On position

This position is similar to Lower (quick coupler B position). It also directs hydraulic oil to quick coupler B except that the lever is held in this position by the hydraulic-lift lock in the control panel. This allows oil to flow continuously to equipment that uses a hydraulic motor. Use this position only when you are operating the machine with an attachment with a hydraulic motor.

Important: If you are using the machine with a hydraulic cylinder or no attachment, the On position causes the oil flow to go over a relief valve, which can damage the hydraulic system. Use this position only momentarily or with a motor attached.

Important: Check the hydraulic oil level after installing an attachment. Check the operation of the attachment by cycling it several times to purge air from system, then check the hydraulic oil level. The attachment cylinder will slightly affect transaxle oil level. Operating the machine with low oil level can damage the pump, remote hydraulics, power steering, and the machine transaxle.

⚠ CAUTION

Hydraulic fluid escaping under pressure can have sufficient force to penetrate skin and do serious damage. Care must be used when connecting or disconnecting hydraulic quick couplers. Stop the engine, apply the parking brake, lower the attachment, and place the remote hydraulic valve in the float detent position to relieve hydraulic pressure before connecting or disconnecting quick couplers.

Connecting the Quick Couplers

Important: Clean dirt from quick couplers before connecting. Dirty couplers can introduce contamination into the hydraulic system.

1. Pull back the locking ring on the coupler.
2. Insert the hose nipple into the coupler until it snaps into position.

Note: When attaching remote equipment to the quick couplers, determine which side requires pressure, then attach that hose to quick coupler B which will have pressure when the control lever is pushed forward or locked in the On position.

Disconnecting the Quick Couplers

Note: With both the machine and attachment turned off, move the lift lever back and forth to remove the system pressure and to make disconnecting the quick couplers easier.

1. Pull back the locking ring on the coupler.

2. Pull the hose firmly from the coupler.

Important: Clean and install the dust plug and dust covers to the quick coupler ends when not in use.

Operating Tips

Operating Characteristics

The machine is designed with safety in mind. It uses familiar automotive style controls, including the steering wheel, brake pedal, and accelerator pedal. It is important to remember, however, that this machine is not a passenger car. It is a work vehicle and is designed for off road use only.

⚠ WARNING

The machine is designed primarily as an off-road vehicle and is not intended for extensive use on public roads.

Occasional use on public roadways should only be undertaken with respect to local traffic regulations and using any additional accessories that may be required by local law (including but not limited to lights, turn signals, slow moving vehicle (SMV) sign, etc).

The machine has special tires, low gear ratios, a locking differential, and other features that give it extra traction. These features add to the versatility of the vehicle but, they can also get you into dangerous situations. You must keep in mind that the vehicle is not a recreation vehicle, it is not an all terrain vehicle, and, it is definitely not meant for stunt driving or horsing around. It is a work vehicle, not a play vehicle. Children should not be allowed to operate the machine. Anyone who operates the machine must be properly trained.

The driver and passenger should always use the seat belts.

If you are not experienced at driving the machine, practice driving it in a safe area away from other people. Be sure you are familiar with all the machine's controls, particularly those used for braking, steering, and transmission shifting. Learn how your machine handles on different surfaces. Your operating skills will improve with experience, but as in operating any vehicle, take it easy as you begin. Be sure you know how to stop quickly in an emergency. If you need help, ask your supervisor for assistance.

Many factors contribute to accidents. You have control over several of the most important. Your actions, such as driving too fast for conditions, braking too fast, turning too sharp, and combinations of these, are frequent cause of accidents.

One of the major causes of accidents is fatigue. Be sure to take occasional breaks. It is very important that you stay alert at all times.

Never operate the machine, or any equipment, if you are under the influence of alcohol or other drugs. Even

prescription drugs and cold medicines can cause drowsiness. Read the label on the medicine or check with your doctor or pharmacist if you are unsure about a certain medication.

One of the most important rules to follow is to go slower in unfamiliar areas. It is surprising how much damage and injury common things can cause. Tree branches, fences, wires, other vehicles, tree stumps, ditches, sand traps, streams, and other things found in most parks and golf courses can be hazardous to the operator and passenger.

Avoid driving when it is dark, especially in unfamiliar areas. If you must drive when it is dark, be sure to drive cautiously, use the head lights, and even consider adding additional lights.

Carrying Passengers

Whenever you have a passenger riding in the machine make sure he or she is wearing the seat belt and holding on securely. Drive slower and turn less sharply because your passenger does not know what you are going to do next and may not be prepared for turning, stopping, accelerating, and bumps.

You and your passenger should remain seated at all times, keeping arms and legs inside the machine. The operator should keep both hands on steering wheel, whenever possible, and the passenger should use the hand holds provided (Figure 38 and Figure 39).

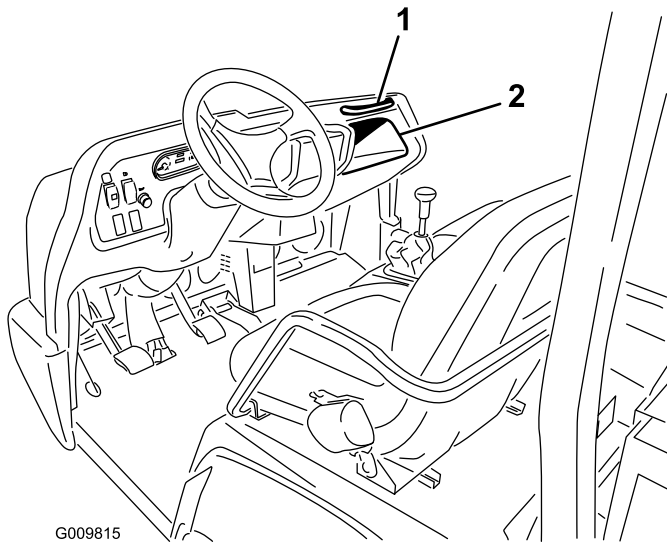

Figure 38

1. Passenger hand hold 2. Storage compartment

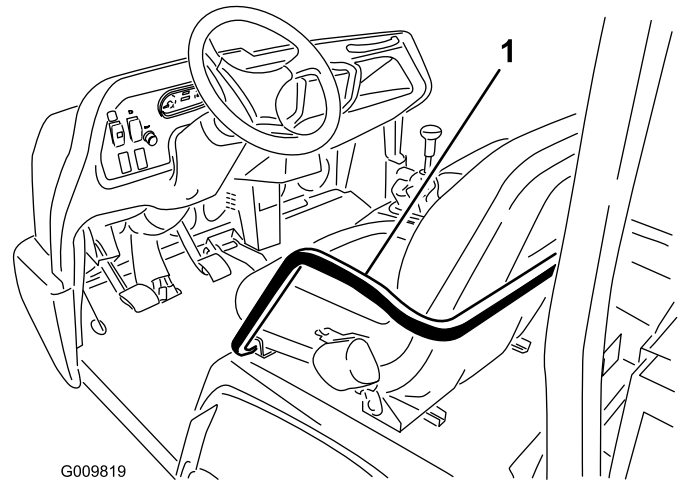

Figure 39

1. Hand hold and hip restraint

Never allow passengers in the dump box or on any attachments. The machine is meant to have 1 driver and only 1 passenger—no more.

Controlling the Speed of the Vehicle

Speed is one of the most important variables leading to accidents. Driving too fast for the conditions can cause you to lose control and have an accident. Speed can also make a minor accident worse. Driving head-on into a tree at slow speed can cause injury and damage, but, driving into a tree at high speed can destroy the machine and kill you and your passenger.

Never drive too fast for the conditions. If there is any doubt about how fast to drive, slow down.

When using heavy attachments, more than 454 kg (1000 lb), such as sprayers, top dressers, or spreaders, etc., restrict your operating speed by selecting low range.

Ensuring Proper Turning

Turning is another important variable leading to accidents. Turning too sharply for the conditions can cause the machine to lose traction and skid, or even tip over.

Wet, sandy, and slippery surfaces make turning more difficult and risky. The faster you are going, the worse this situation becomes so, slow down before turning.

During a sharp turn at higher speeds, the inside rear wheel may lift off the ground. This is not a flaw in the design, it happens with most four wheel machines including passenger cars. If this happens, you are turning too sharply for the speed at which you are traveling. **Slow down!**

Ensuring Proper Braking

It is good practice to slow down before you get near an obstacle. This gives you extra time to stop or turn away. Hitting an obstacle can damage the machine and its contents.

More important, it can injure you and your passenger. Gross machine weight has a major impact on your ability to stop or turn. Heavier loads and heavier attachments make a machine harder to stop or turn. The heavier the load, the longer it takes to stop.

The braking characteristics also change with no bed or attachment on the machine. Fast stops may cause the rear wheels to lock up before the front wheels lock up, which may affect the control of the machine. It is a good idea to decrease machine speed with no bed or attachment.

Turf and pavement are much slipperier when they are wet. It can take 2 to 4 times as long to stop on wet surfaces as on dry surfaces.

If you drive through standing water deep enough to get the brakes wet, they will not work well until they are dry. After driving through water, you should test the brakes to make sure that they work properly. If they do not, drive slowly while putting light pressure on the brake pedal. This will dry out the brakes .

Preventing Tip Overs

The machine is equipped with a roll bar, hip restraints, seat belts, and hand hold. The ROPS system (Rollover Protection System) used on the machine will reduce the risk of serious or fatal injury in the unlikely event of a tip over, although the system cannot protect the operator from all possible injuries.

Replace a damaged ROPS, do not repair it. Any alteration of the ROPS must be approved by the manufacturer.

The best way to prevent accidents involving utility machines is through continuous supervision and training of operators and paying constant attention to the area in which machine is being operated.

The best way for operators to prevent serious injury or death to themselves or others, is to familiarize themselves with the proper operation of the utility machine, to stay alert and to avoid actions or conditions which could result in an accident. In the event of a tip over, the risk of serious injury or death will be reduced if the operator is using the ROPS system and seat belts and is following the instructions provided.

Operating the Machine on Hills

⚠ WARNING

Tipping or rolling the machine on a hill will cause serious personal injury.

- **Do not operate the machine on steep slopes.**
- **If engine stalls or you lose headway on a hill, never attempt to turn machine around.**
- **Always back straight down a hill in Reverse.**
- **Never back down in Neutral using only the brakes.**
- **Never drive across a steep hill, always drive straight up or down.**
- **Avoid turning on a hill.**
- **Don't slam on the brakes. A sudden speed change can initiate a tip over.**

Use extra care when on hills. Never go on hills that are extremely steep. Stopping while going down a hill will take longer than on level ground. Turning while going up or down a hill is more dangerous than turning on the level. Making turns while going down hill, especially with the brakes on, and turning uphill while traversing a hill are particularly dangerous. Even at a slow speed and without a load, tip overs are more likely if you turn on a hill.

If you have to turn while on a hill, do it as slowly and cautiously as possible. Never make sharp or fast turns on a hill.

If you stall or begin to lose headway while climbing a steep hill, quickly apply the brakes, shift to Neutral, restart the engine and shift to Reverse.

Reduce the weight of the load if it is a steep hill or if the load has high center of gravity. Remember, loads can shift, so secure them.

Note: The machine has excellent hill-climbing ability. The differential lock will increase this ability. Hill climbing traction can also be increased by adding weight to the rear of the machine in one of the following ways:

- Adding weight to inside of box, making sure that it is secured
- Mounting wheel weights to rear wheels
- Adding liquid ballast (calcium chloride) to rear tires
- Not having a passenger in the front seat

Maintenance

Determine the left and right sides of the machine from the normal operating position.

Note: Looking for an *Electrical Schematic* or *Hydraulic Schematic* for your machine? Download a free copy of the schematic by visiting www.Toro.com and searching for your machine from the Manuals link on the home page.

⚠ WARNING

In certain conditions, gasoline is extremely flammable and highly explosive. A fire or explosion from gasoline can burn you and others and can damage property.

Avoid fire hazards and have fire protection equipment present in the work area. Do not use an open flame to check level or leakage of fuel, battery electrolyte, or coolant. Do not use open pans of fuel or flammable cleaning fluids for cleaning parts.

⚠ CAUTION

Not properly maintaining the machine could damage it and /or cause injury to you or bystanders.

Allow only qualified and authorized personnel to maintain, repair, adjust, and inspect the machine.

⚠ CAUTION

If you leave the key in the ignition switch, someone could accidentally start the engine and seriously injure you or other bystanders.

Remove the key from the ignition before you do any maintenance.

Recommended Maintenance Schedule(s)

Maintenance Service Interval	Maintenance Procedure
After the first 2 hours	<ul style="list-style-type: none"> • Torque the front and rear wheel nuts.
After the first 10 hours	<ul style="list-style-type: none"> • Torque the front and rear wheel nuts. • Check the adjustment of the parking brake. • Replace the hydraulic filter.
After the first 50 hours	<ul style="list-style-type: none"> • Change the engine oil and filter. • Inspect opening on filter. • Check the transmission fluid level.
After the first 100 hours	<ul style="list-style-type: none"> • Perform the breaking-in a new machine guidelines.
Before each use or daily	<ul style="list-style-type: none"> • Check the engine-oil level. (Check the oil level before and after the engine is first started and daily thereafter.) • Check the hydraulic-fluid level. (Check the level of hydraulic fluid before the engine is first started and daily thereafter.) • Check the level of the coolant. Check the Coolant level at the overflow reservoir only. Do Not remove the radiator cap. (Check the coolant level before the engine is first started and daily thereafter.) • Check the brake fluid level. (Check the level before the engine is first started and daily thereafter.) • Check the oil-pressure warning light. • Check the tire pressure. • Remove debris from the engine area and radiator. (Clean it more frequently in dirty conditions.) • Check the operation of the interlock system.
Every 50 hours	<ul style="list-style-type: none"> • Check the condition of the battery (every 30 days if the battery is in storage). • Check the battery cable connections.
Every 100 hours	<ul style="list-style-type: none"> • Grease all bearings and bushings (lubricate more frequently in heavy duty applications). • Check the condition of the tires. • Check the constant velocity boots for damage and leaking lubricant.

Maintenance Service Interval	Maintenance Procedure
Every 200 hours	<ul style="list-style-type: none"> • Change the air-cleaner filter (more frequently in dusty or dirty conditions). • Change the engine oil and filter. • Inspect opening on filter. • Torque the front and rear wheel nuts • Check the fluid level in the reservoir for the speed control cylinder. • Check the adjustment of the parking brake. • Check the adjustment of the brake pedal. • Inspect the service and parking brakes.
Every 400 hours	<ul style="list-style-type: none"> • Inspect or replace the spark plug. • Replace the fuel filter. • Check the fuel lines and connections. • Check the front wheel alignment. • Check the transmission fluid level. • Check the condition of the drive belt. • Clean the clutches. • Visually inspect the brakes for worn brake shoes.
Every 800 hours	<ul style="list-style-type: none"> • Replace the hydraulic filter. • Change the hydraulic fluid and clean the strainer.
Every 1,000 hours	<ul style="list-style-type: none"> • Change the brake fluid. • Drain/flush the fuel tank. • Flush/replace the coolant system fluid.
Yearly	<ul style="list-style-type: none"> • Complete all of the yearly maintenance procedures specified in the engine owner's manual.

Heavy Duty Operation

Important: If the machine is subjected to any of the following conditions listed below, perform the maintenance procedures at half the recommended service interval.:

- Operating the machine in a desert environment
- Operating the machine in a cold climate—below 0 degrees C (32 degrees F)
- Using the machine to tow a trailer
- Frequently operating the machine on dusty roads
- Using the machine for construction work
- After using the machine in mud, sand, water, or similar dirty conditions for an extended time

Note: Have your brakes inspected and cleaned as soon as possible after each use. This will prevent any abrasive material from causing excessive brake wear.

Premaintenance Procedures

Many of the subjects covered in this maintenance section require raising and lowering the bed. The following precautions must be taken or serious injury or death could result.

Important: Before servicing or making adjustments to the machine, stop the engine, set the parking brake, and remove the key from the ignition switch. Remove any load material from the bed or other attachment before working under a raised bed. Never work under a raised bed without positioning the safety support on a fully extended cylinder rod.

Using the Bed Safety Support

Important: Always install or remove the bed support from the outside of the bed.

1. Raise the bed until the lift cylinders are fully extended.
2. Remove the bed support from the storage brackets on back of the ROPS panel (Figure 40).

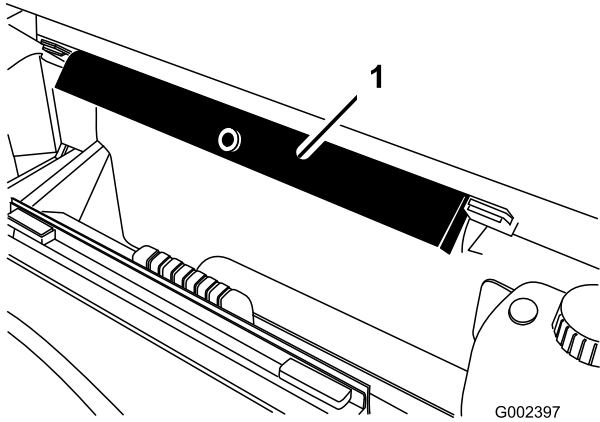

Figure 40

1. Bed support

3. Push the bed support onto the cylinder rod, making sure that the support end tabs rest on the end of cylinder barrel and on the cylinder rod end (Figure 41).

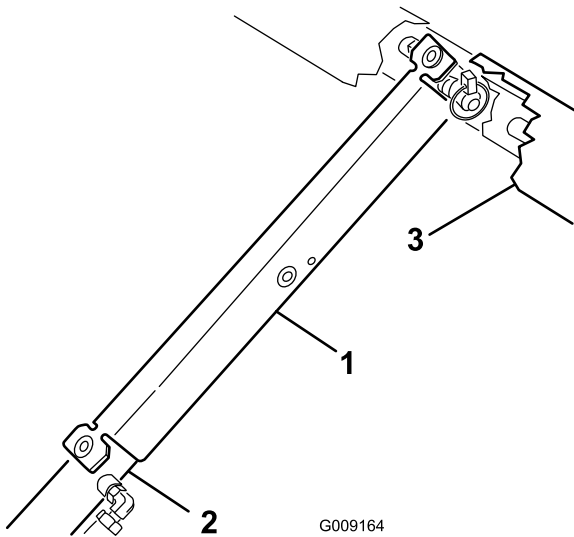

Figure 41

1. Bed support
2. Cylinder barrel
3. Bed

4. When finished, remove the bed support from the cylinder and insert it into the brackets on the back of the ROPS panel.

Important: Do not try to lower bed with bed safety support on cylinder.

Removing the Full Bed

Full bed weight: approximately 147.5 kg (325 lb)

1. Start the engine.
2. Move the hydraulic lift lever forward and lower the bed until the cylinder rod ends are loose in the slots (Hydraulic Lift Lever (page 16)).
3. Release the lift lever and turn off the engine.
4. Remove the lynch pins from the outer ends of the cylinder rod clevis pins (Figure 42).

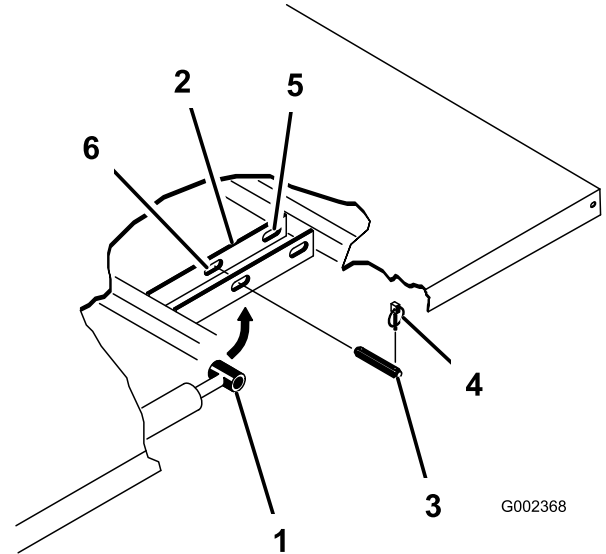

Figure 42

1. Cylinder rod end
2. Bed mounting plate
3. Clevis pin
4. Lynch pin
5. Rear slot (Full bed)
6. Front slot (2/3 bed)

5. Remove the clevis pins securing the cylinder rod ends to the bed mounting plates by pushing the pins toward the inside (Figure 42).
6. Remove the lynch pins and clevis pins securing the pivot brackets to the frame channels (Figure 42).
7. Lift the bed off the machine.

Important: The full bed weighs approximately 147.5 kg (325 lb), so do not try to install or remove it by yourself. Use an overhead hoist or get the help of 2 or 3 other people.

8. Store the cylinders in the storage clips.
9. Set the hydraulic lift lock lever on the machine to the Lock position; refer to .

Note: Lock the lever to prevent the lift cylinders from extending.

Installing the Full Bed

Full bed weight: approximately 147.5 kg (325 lb)

Note: If the bed sides will be installed on the flat bed, it is easier to install them before installing the bed on the machine.

Note: Ensure that the rear pivot plates are bolted to the bed frame/channel so that lower end angles to the rear (Figure 43).

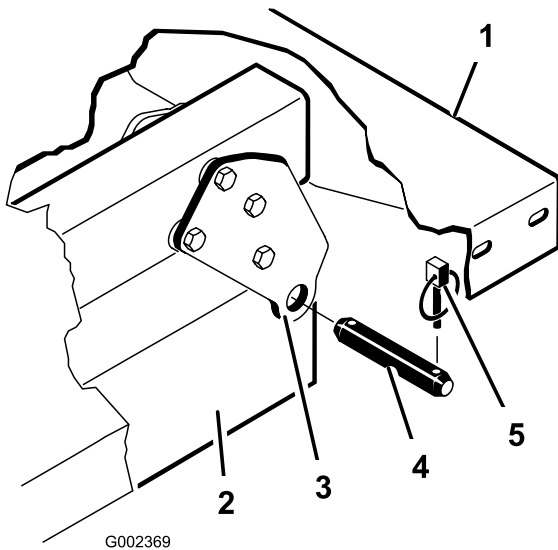

Figure 43

- | | |
|----------------------------|---------------|
| 1. Left rear corner of bed | 4. Clevis pin |
| 2. Frame channel | 5. Lynch pin |
| 3. Pivot plate | |

Note: Install the spacer brackets and wear blocks (Figure 44) with the carriage bolt heads positioned inside the machine.

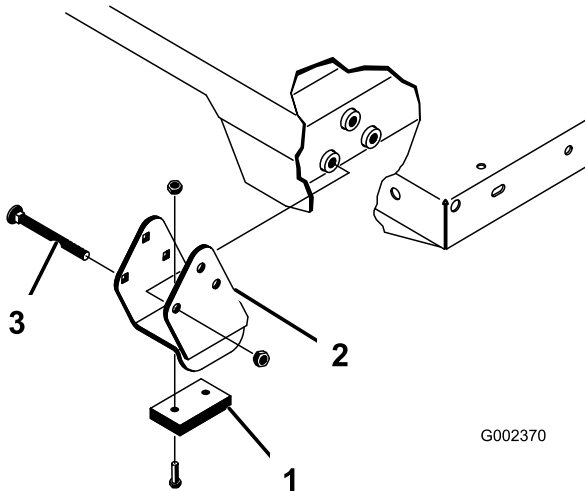

Figure 44

- | | |
|-------------------|------------------|
| 1. Wear block | 3. Carriage bolt |
| 2. Spacer bracket | |

in the rear frame channel and install 2 clevis pins and lynch pins (Figure 44).

Important: The full bed weighs approximately 147.5 kg (325 lb), so do not try to install or remove it by yourself. Use an overhead hoist or get the help of 2 or 3 other people.

3. With the bed lowered, secure each cylinder rod end, to the appropriate slots in the bed mounting plates with a clevis pin and lynch pin.

Note: You may need to start the engine to extend or retract the cylinders to align them with the holes. **Keep fingers away!**

4. Insert the clevis pin from outside of the bed with the lynch pin toward the outside (Figure 44).

Note: The rear slots are for a full bed installation and front slots are for a 2/3 bed installation.

Note: The unused slot can be plugged with a bolt and a nut to prevent assembly errors.

5. Start the engine and engage the hydraulic lift lever to raise the bed.
6. Release the lift lever and turn off the engine.
7. Install the bed safety support to prevent accidental lowering of the bed. Refer to [Using the Bed Safety Support](#) (page 36).
8. Install the lynch pins to the inside ends of the clevis pins.

Note: If the automatic tail gate release has been installed on the bed, ensure that the front dump link rod has been placed on the inside of the left side clevis pin before the lynch pin is installed.

Jacking the Machine

⚠ DANGER

A machine on a jack may be unstable and slip off of the jack, injuring anyone beneath it.

- Do not start the engine while the machine is on a jack.
- Always remove the key from the switch before getting off of the machine.
- Block the tires when the machine is on a jack.
- Do not work under the machine without jack stands supporting it. The machine could slip off a jack, injuring anyone beneath it.
- When jacking up the front of the machine, always place a 2 x 4 block (or similar material) between the jack and the machine frame.
- The jacking point at the front of the machine is under the front center frame support (Figure 45). At the rear of the machine, the jacking point is under the axle (Figure 46).

1. Ensure that the lift cylinders are fully retracted.
2. Carefully set the bed onto the frame of the machine, aligning the rear bed pivot plate holes with the holes

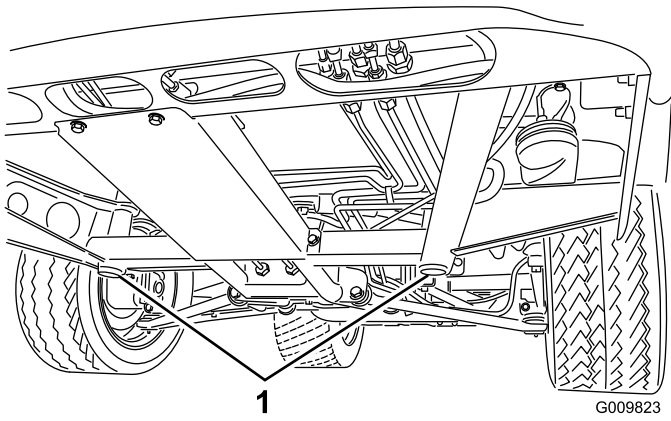

Figure 45

1. Front jacking points

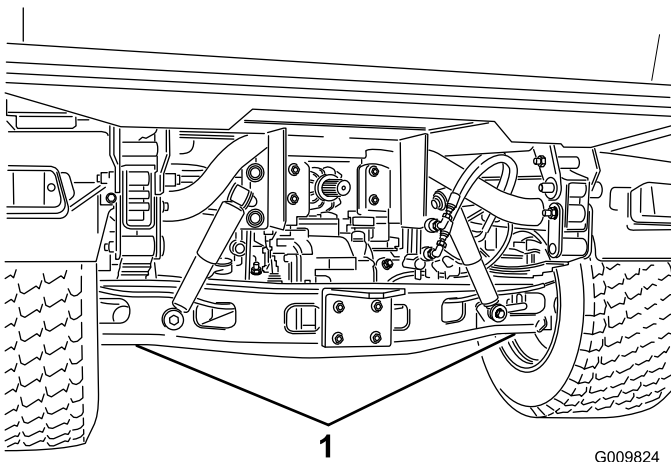

Figure 46

1. Rear jacking points

Removing and Installing the Hood

Removing the Hood

Remove the hood as follows:

1. While grasping the hood in the headlight openings, lift up the hood to release the lower mounting tabs from the frame slots ([Figure 47](#)).

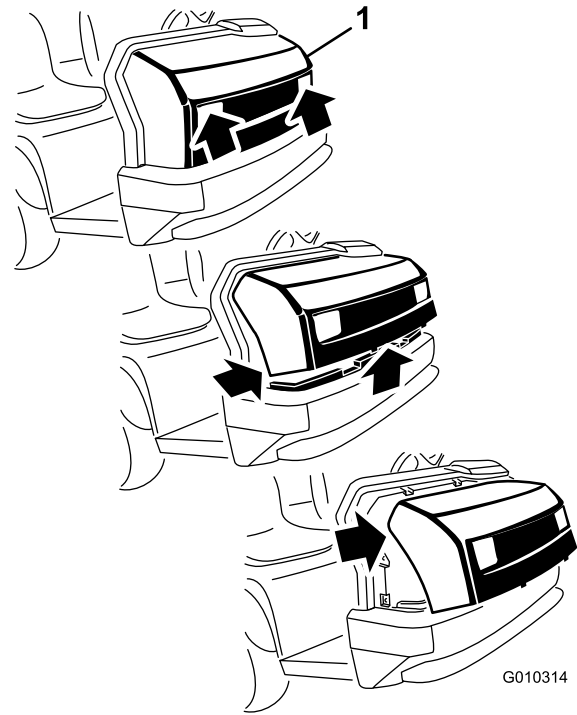

Figure 47

1. Hood
2. Pivot the bottom of the hood upward until you can pull the top mounting tabs from the frame slots ([Figure 47](#)).
3. Pivot the top of hood forward and unplug the wire connectors from the head lights ([Figure 47](#)).
4. Remove the hood.

Installing the Hood

1. Connect the lights.
2. Insert the top mounting tabs into the frame slots ([Figure 47](#)).
3. Insert the lower mounting tabs into the frame slots ([Figure 47](#)).
4. Ensure that the hood is fully engaged in the top, sides, and bottom grooves.

Lubrication

Greasing the Bearings and the Bushings

Service Interval: Every 100 hours (lubricate more frequently in heavy duty applications).

Lubrication type: No. 2 general-purpose, lithium-based grease

Important: When greasing the drive shaft universal shaft bearing crosses, pump grease until it comes out of all 4 cups at each cross.

1. Wipe each grease fitting clean so that foreign matter cannot be forced into the bearing or bushing.
2. Connect the grease gun to the grease fitting.
3. Pump grease into each bearing or bushing.
4. Wipe off any excess grease.

The grease fitting locations and quantities are as follows:

- **Ball joints** (4); refer to [Figure 48](#)
- **Pivot mounts** (2); refer to [Figure 48](#)
- **Steering cylinder** (2); refer to [Figure 48](#)
- **Tie rods** (2); refer to [Figure 48](#)

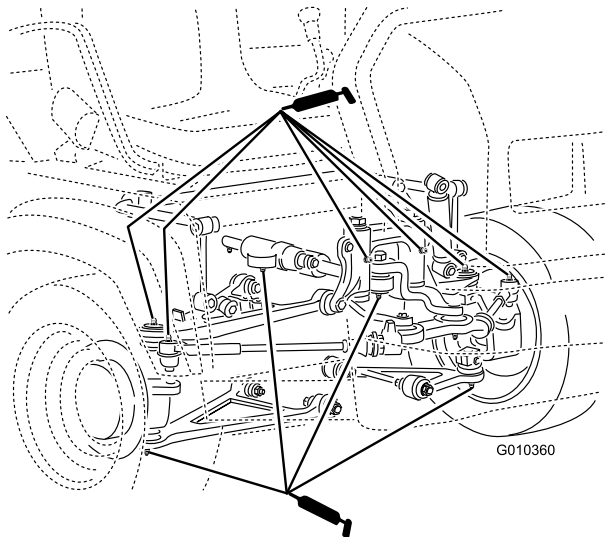

Figure 48

Spring tower (2); refer to [Figure 49](#)

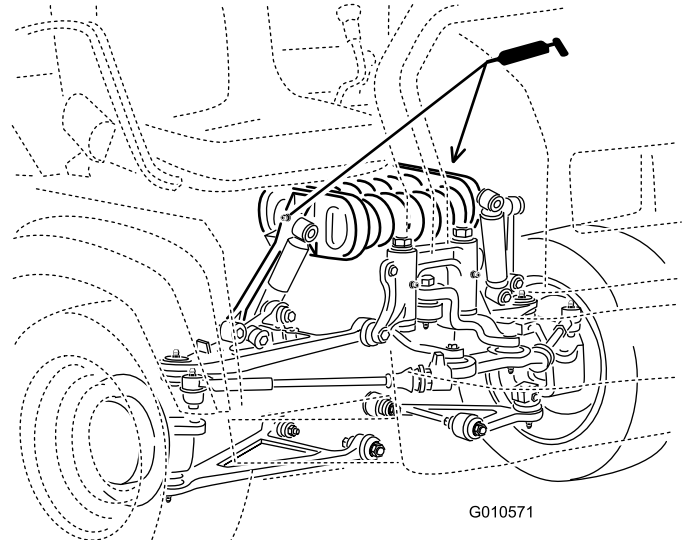

Figure 49

- **Brake** (1); refer to [Figure 50](#)
- **Throttle** (1); refer to [Figure 50](#)

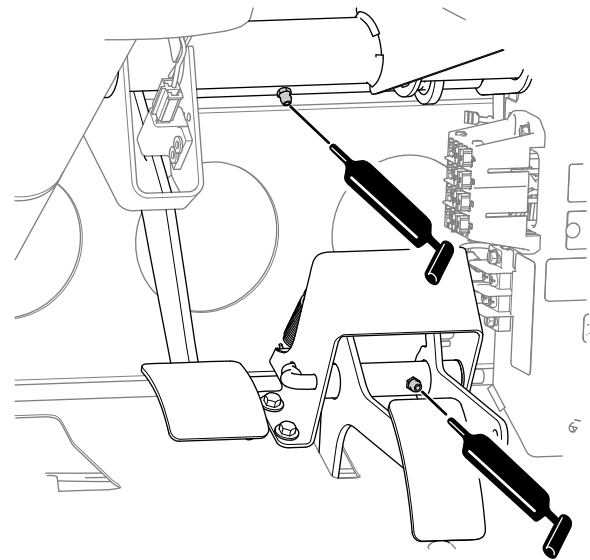

Figure 50

- Drive shaft U-joints (2); refer to [Figure 51](#)
- Sliding yolk (1); refer to [Figure 51](#)

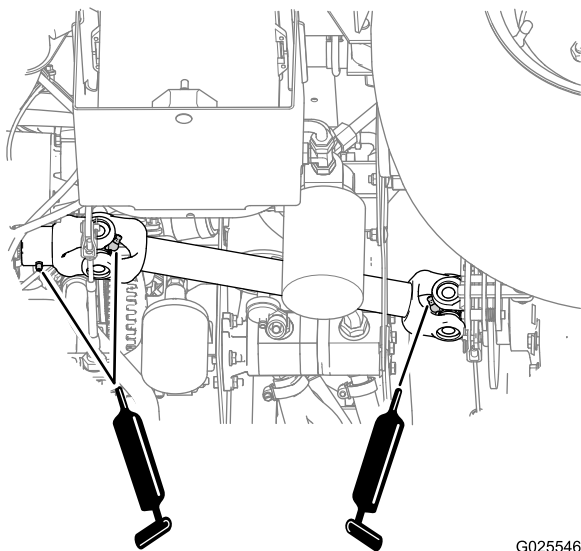

Figure 51

Engine Maintenance

Servicing the Air Filter

Service Interval: Every 200 hours—Change the air-cleaner filter (more frequently in dusty or dirty conditions).

Inspect the air filter and hoses periodically to maintain maximum engine protection and to ensure maximum service life. Check the air—filter cover and housing for damage which could possibly cause an air leak. Replace any damaged air-filter components.

Inspect and change the air filter as described in the following procedure:

1. Pull the latch outward and rotate the air-filter cover counterclockwise ([Figure 52](#)).

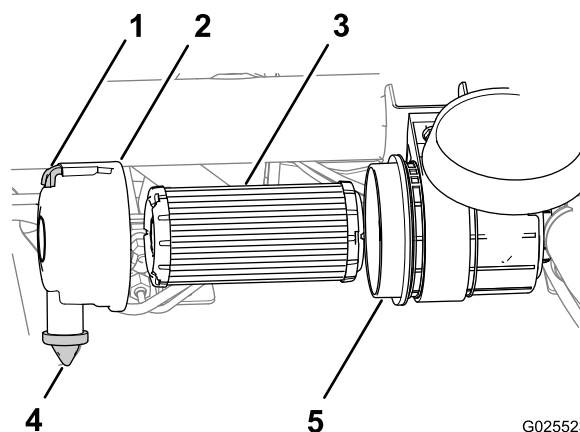

Figure 52

- | | |
|---------------------|-----------------------|
| 1. Latch | 4. Dust valve |
| 2. Air-filter cover | 5. Air-filter housing |
| 3. Air filter | |

2. Before removing the filter, use low pressure air (40 psi, clean and dry) to help remove large accumulations of debris packed between the outside of the air filter and the air-filter housing.

Important: Avoid using high pressure air, which could force dirt through the filter into the intake tract. This cleaning process prevents debris from migrating into the intake when the primary filter is removed.

3. Remove air filter from the housing ([Figure 52](#)).

Note: Do not clean a used filter element because you may damage filter media.

4. Wipe clean the interior of the air-filter cover and housing ([Figure 52](#)).
5. Remove the rubber dust valve from the cover ([Figure 52](#)).

Replacing the Spark Plug

Service Interval: Every 400 hours

Spark plug type: Champion RC14YC

Air gap: 0.76 mm (0.030 inch)

1. Clean the area around the spark plug so foreign matter cannot fall into the cylinder when you remove the spark plug.
2. Pull wires off the spark plug and remove the plugs from the cylinder head.
3. Check the condition of the side electrode, center electrode, and center electrode insulator to ensure that there is no damage (Figure 56).

Important: A cracked, fouled, dirty, or otherwise malfunctioning spark plug must be replaced. Do not sand blast, scrape, or clean electrodes by using a wire brush because grit may eventually release from the plug and fall into the cylinder and damaged the engine.

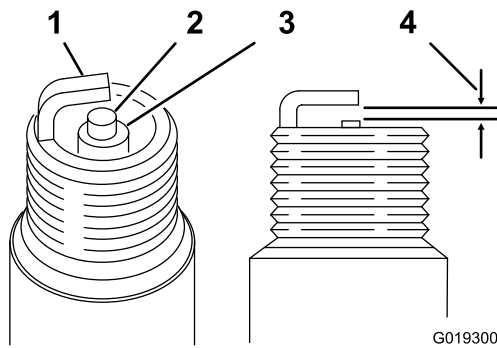

Figure 56

1. Side electrode
2. Center electrode
3. Insulator
4. Air gap at 0.76 mm (0.030 inch)

4. Set the air gap (Figure 56) between the center and side electrodes at 0.81 mm (0.032 inch).
5. Install the correctly gapped spark plug and tighten them to 24.5 to 29 N-m (18 to 22 ft-lb).

Note: If you cannot use a torque wrench, tighten the plug firmly.

6. Install the spark-plug wire.

Fuel System Maintenance

Replacing the Fuel Filter

Service Interval: Every 400 hours

1. Raise the bed (if so equipped) and install the bed safety support onto the extended lift cylinder to hold up the bed; refer to [Raising the Cargo Box \(page 19\)](#) and [Using the Bed Safety Support \(page 36\)](#).
2. Unplug the wiring harness connectors from the fuel pump (Figure 57).
3. Loosen the hose clamp and disconnect the fuel line from the fuel pump cap (Figure 57).

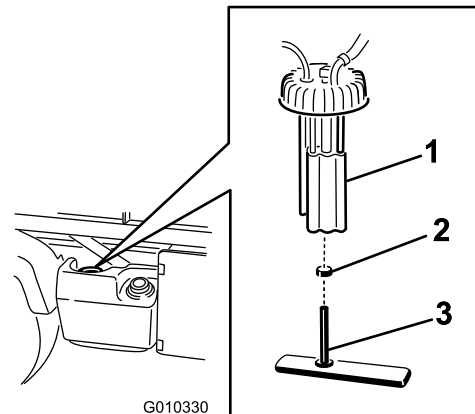

Figure 57

1. Fuel pump
2. Hose clamp
3. Fuel line/fuel filter

4. Remove the fuel-pump cap by unthread it from the top of the fuel tank (Figure 57).

Important: Do not allow the fuel pump assembly to rotate during the removal process. If the pump rotates, it can result in damage to the float arm assembly.

5. Remove the fuel pump assembly and fuel filter from the tank (Figure 57).
6. Remove the clamp securing the fuel filter hose to the fuel pump fitting (Figure 57).
7. Remove the hose from the fitting (Figure 57).
8. Insert the new hose clamp onto the new fuel filter hose.
9. Insert the hose onto the fuel pump and secure the clamp.
10. Insert the assembly into the fuel tank and tighten the cap to 20 to 22 N-m (175 to 200 in-lb).

Note: Note: Verify that the float arm does not contact the fuel tank walls at any point through the full range of motion.

11. Connect the wires and secure the hose with the hose clamp.

Inspecting the Carbon Canister Air Filter

Service Interval: After the first 50 hours
Every 200 hours

1. Locate the air filter on the bottom of the carbon canister (Figure 58).

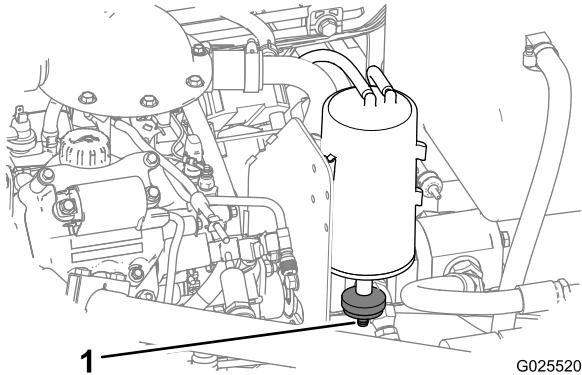

Figure 58

1. Filter opening

2. Ensure that the opening on the bottom of the filter is clear and open.

Inspecting the Fuel Lines and Connections

Service Interval: Every 400 hours/Yearly (whichever comes first)

Every 1,000 hours/Every 2 years (whichever comes first)

Inspect the fuel lines and connections for deterioration, damage, or loose connections.

Electrical System Maintenance

Servicing the Fuses

The fuses for the electrical system are located under the center of the dash panel (Figure 59 and Figure 60).

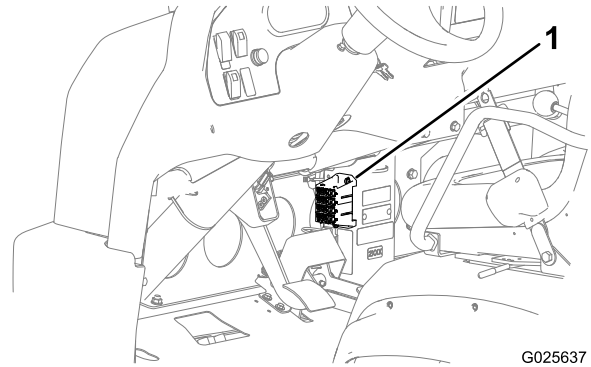

Figure 59

1. Fuses

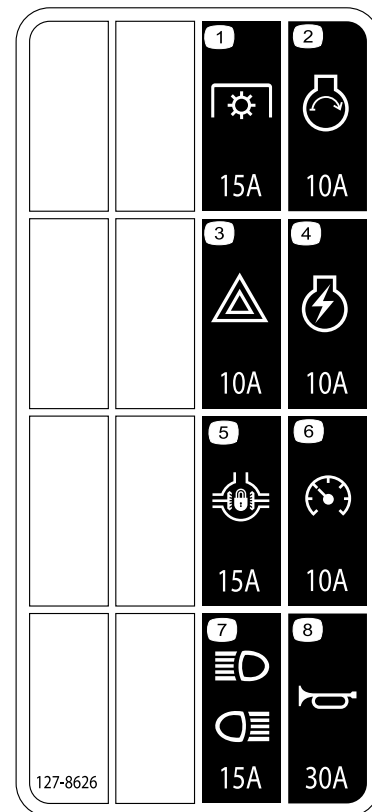

Figure 60

- | | |
|------------------------|-----------------------------------|
| 1. Power take-off—15A | 5. Differential lock—15A |
| 2. Engine start—10A | 6. Speedometer—10A |
| 3. Hazards—10A | 7. Headlights and rear lights—15A |
| 4. Engine ignition—10A | 8. Horn—30A |

Jump-Starting the Machine

⚠ WARNING

Jump-starting can be dangerous. To avoid personal injury or damage to electrical components in machine, observe the following warnings:

- Never jump-start with a voltage source greater than 15 volts DC. This will damage the electrical system.
- Never attempt to jump start a discharged battery that is frozen. It could rupture or explode during jump starting.
- Observe all battery warnings while jump starting your machine.
- Ensure that the machine is not touching the jump start machine.
- Connecting cables to the wrong post could result in personal injury and/or damage to the electrical system.

1. Squeeze the battery cover to release the tabs from battery base, and remove the battery cover from the battery base (Figure 61).

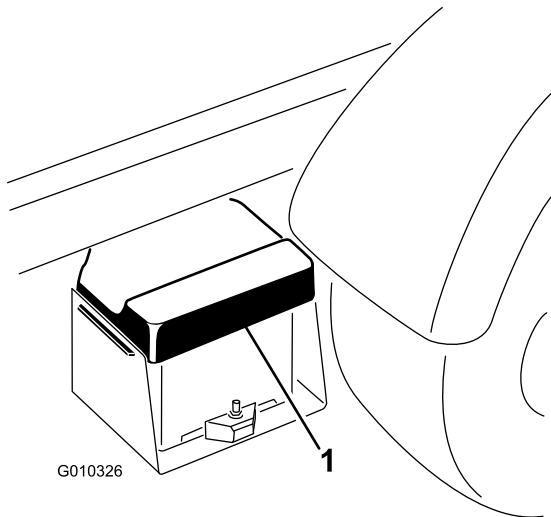

Figure 61

1. Battery cover

2. Connect a jumper cable between the positive posts of the 2 batteries (Figure 62).

Note: The positive post may be identified by a + sign on top of the battery cover.

3. Connect the end of the other jumper cable to the negative terminal of the battery in the other machine.

Important: Do not connect the jumper cable to the fuel system.

Note: The negative terminal has NEG on the battery cover. Do not connect the other end of the jumper cable to the negative post of the discharged battery—connect it to the engine or frame.

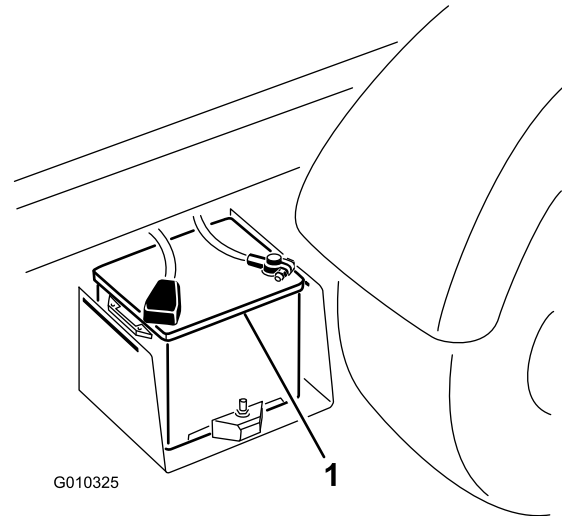

Figure 62

1. Battery

4. Start the engine of the machine that provides the electrical source for the jump start.

Note: Let machine that provides the electrical source run a few minutes, then start your engine.

5. Remove the negative jumper cable first from your engine, then the battery in the other vehicle.
6. Install the battery cover to the battery base.

Servicing the Battery

Service Interval: Every 50 hours—Check the condition of the battery (every 30 days if the battery is in storage).

Every 50 hours—Check the battery cable connections.

WARNING

CALIFORNIA Proposition 65 Warning

Battery posts, terminals, and related accessories contain lead and lead compounds, chemicals known to the State of California to cause cancer and reproductive harm. Wash hands after handling.

▲ DANGER

Battery electrolyte contains sulfuric acid, which is a deadly poison and causes severe burns.

- Do not drink electrolyte and avoid contact with skin, eyes or clothing. Wear safety glasses to shield your eyes and rubber gloves to protect your hands.
- Fill the battery where clean water is always available for flushing the skin.
- Keep the top of the battery clean by washing it periodically with a brush dipped in ammonia or bicarbonate of soda solution. Flush the top surface with water after cleaning. Do not remove the fill cap while cleaning.
- Ensure that the battery cables are kept tight on the terminals to provide good electrical contact.
- If corrosion occurs at terminals, remove the battery cover, disconnect the cables (negative (-) cable first), and scrape the clamps and terminals separately. Connect the cables (positive (+) cable first) and coat the terminals with petroleum jelly.
- If you store the machine in a location where temperatures are extremely high, the battery will run down more rapidly than if the machine is stored in a location where temperatures are cool.

Drive System Maintenance

Maintaining the Tires, Wheels, and Suspension

Inspecting the Tires

Service Interval: Every 100 hours

Operating accidents, such as hitting curbs, can damage a tire or rim and also disrupt wheel alignment, so inspect tire condition after an accident.

Check the tire pressure frequently to ensure proper inflation. If the tires are not inflated to the correct pressure, the tires will wear prematurely.

Figure 63 shows an example of tire wear caused by under inflation.

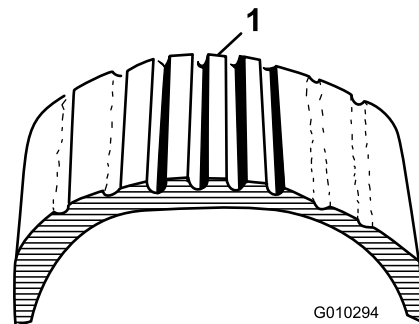

Figure 63

1. Under inflated tire

Figure 64 shows an example of tire wear caused by over inflation.

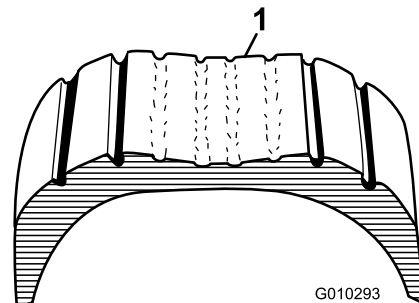

Figure 64

1. Over inflated tire

Checking the Torque of the Wheel Nuts

Service Interval: After the first 2 hours

After the first 10 hours

Every 200 hours

⚠ WARNING

Failure to maintain proper torque of the wheel nuts could result in failure or loss of a wheel and may result in personal injury.

Torque the front and rear wheel nuts to 109 to 122 N-m (80 to 90 ft-lb) after 1 to 4 hours of operation and again after 10 hours of operation. Torque the wheel nuts every 200 hours thereafter.

Checking the Front Wheel Alignment

Service Interval: Every 400 hours/Yearly (whichever comes first)

1. Make sure that the tires are facing straight ahead.
2. Measure the center-to-center distance (at axle height) at the front and rear of the steering tires (Figure 65).

Note: The measurement must be within 0 ± 3 mm (0 ± 0.12 inch) at the front of the tire then at the rear of the tire.

Important: Check the measurements at consistent locations on the tire. The vehicle should be on a flat surface with the tires facing straight ahead.

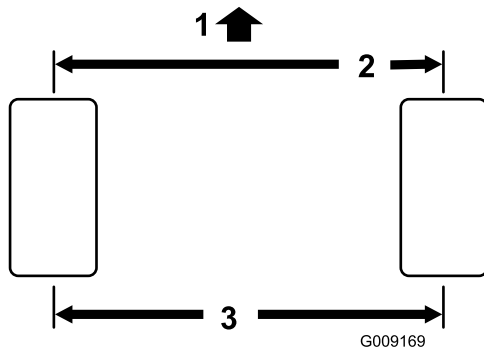

Figure 65

1. Front of vehicle
2. 0 ± 3 mm (0 ± 0.12 inch) front to rear of tire
3. Center to center distance

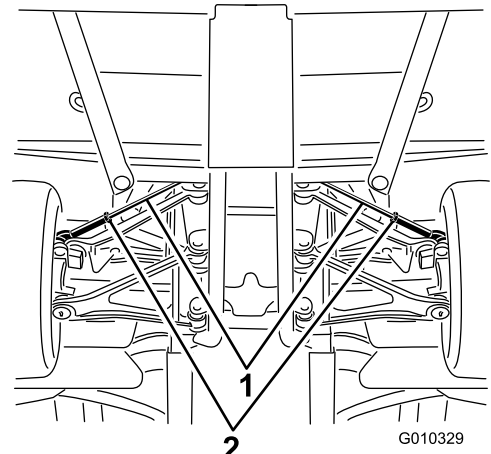

Figure 66

1. Tie rods
2. Jam nuts

- B. Rotate the tie rod to move the front of the tire inward or outward to achieve the center to center distances from front to back.
- C. Tighten the tie rod jam nut when the adjustment is correct.
- D. Check to ensure that the tires turn an equal amount to the right and to the left.

Note: If the tires do not turn equally, refer to the Workman Service Manual for the adjustment procedure.

3. Rotate the tire 90 degrees and check the measurements again.

Note: The measurement must be within 0 ± 3 mm (0 ± 0.12 inch) at the front of the tire then at the rear of the tire.

4. Adjust the center-to-center distance as follows:
 - A. Loosen the jam nut at the center of the tie rod (Figure 66).

Maintaining the Transmission

Checking the Transmission-fluid Level

Service Interval: After the first 50 hours

Every 400 hours

Transmission Fluid Type: Dexron VI

1. Locate the fill plug at the at the lower-inboard area at the back of the transmission (Figure 67).

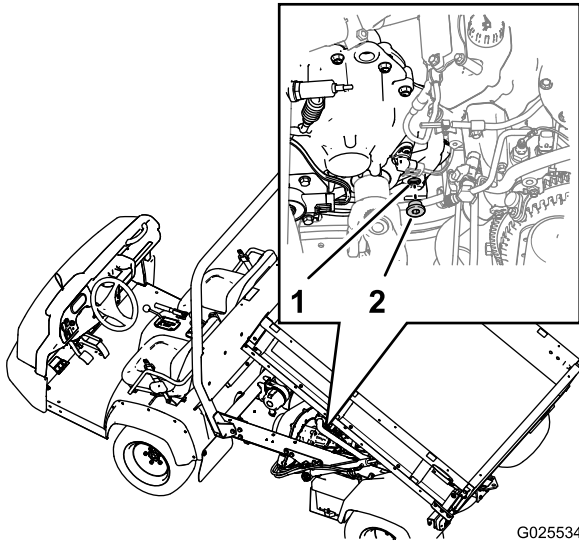

Figure 67

1. Fill port (transmission)
2. Fill plug

2. Align a drain pan below the fill plug.
 3. Rotate the plug counterclockwise and remove the plug from the fill port in the transmission (Figure 67).
- Note:** When the transmission fluid level is correct, the fluid should be level with the bottom of the threads in the fill port.
4. If the transmission-fluid level is low, add transmission fluid of the specified type into the transmission through the fill port until the fluid level is flush with the bottom of the threads in the port (Figure 67).

Note: Use a funnel with a flexible hose when filling the transmission.

5. Check the condition of the O-ring at the fill plug.

Note: Replace the O-ring if it is worn or damaged.

6. Install the fill plug into the transmission and tighten it hand tight (Figure 67).

Changing the Transmission Fluid

Transmission Fluid Type: Dexron VI

Transmission Fluid Capacity: 700 ml (23.7 oz)

1. Move the machine to a level surface.
2. Locate the fill plug at the back inboard area of the transmission case and locate the drain plug at the front outboard side of the transmission (Figure 68 and Figure 69).

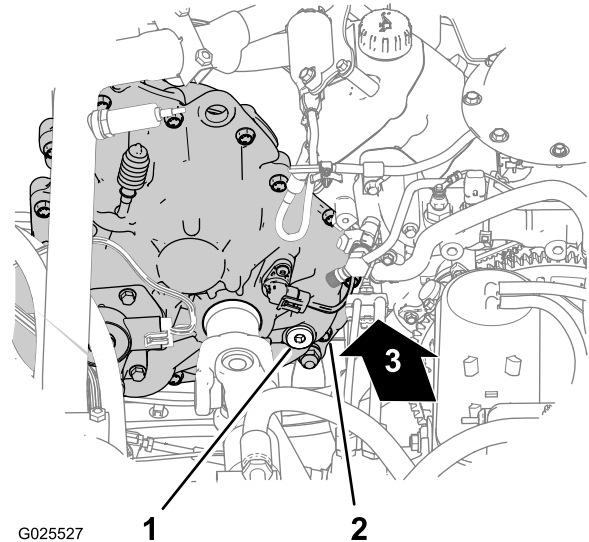

Figure 68

1. Fill plug
2. Transmission case (back inboard location)
3. Forward

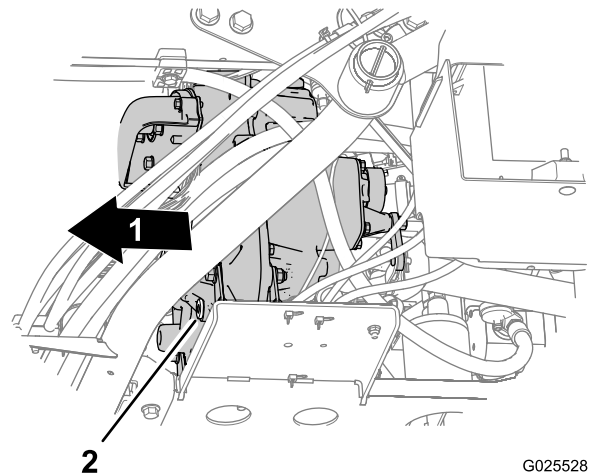

Figure 69

1. Forward
2. Drain plug

3. Remove the fill plug from the fill port by rotating the plug counterclockwise and removing it from the transmission (Figure 68).
4. Align a drain pan below the drain plug (Figure 69).

- Remove the drain plug from the drain port by rotating the plug counterclockwise and removing it from the transmission (Figure 69).

Note: Allow the transmission fluid to drain completely.

- Install the drain plug (Figure 69).
- Add 700 ml (23.7 oz) of Dexron VI transmission fluid into the transmission through the fill port (Figure 68).

Note: Use a funnel with a flexible hose when filling the transmission.

Note: When the transmission fluid level is correct, the fluid should be level with the bottom of the threads in the fill port.

- Install the fill plug (Figure 68).

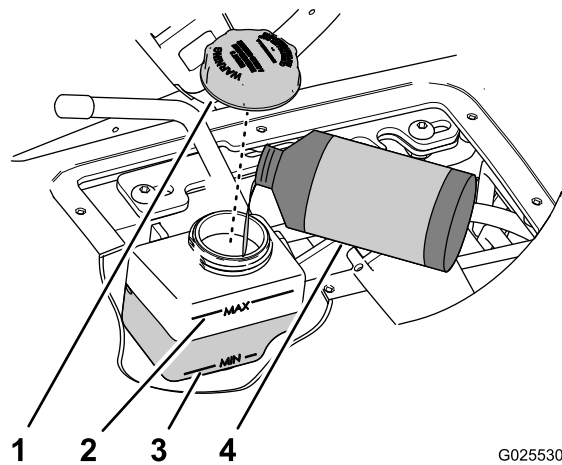

Figure 71

- | | |
|-------------------------|-------------------------|
| 1. Cap | 3. Min mark (reservoir) |
| 2. Max mark (reservoir) | 4. DOT 3 brake fluid |

Servicing the Reservoir of the Speed-control Cylinder

Service Interval: Every 200 hours

Reservoir Fluid Type: DOT 3 brake fluid

- Remove the knobs from the hydraulic-lift lever and the speed-range lever (Figure 70).

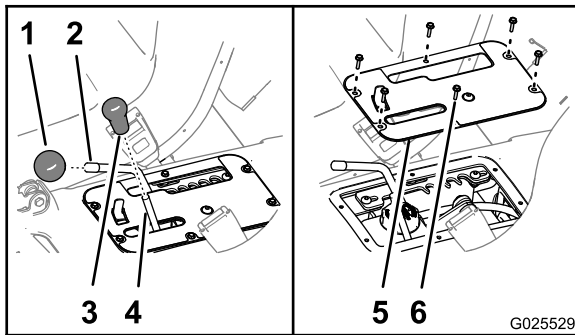

Figure 70

- | | |
|--------------------------------|---------------------------------------|
| 1. Knob (speed-range lever) | 4. Rod (hydraulic-lift lever) |
| 2. Rod (speed-range lever) | 5. Control-cover plate |
| 3. Knob (hydraulic-lift lever) | 6. Hex-washer screws (#10 x 3/4 inch) |

- Remove the 6 hex-washer screws (#10 x 3/4 inch) that secure the control-cover plate to the seat base, and remove the cover plate (Figure 70).
- Move the speed-range lever to the transport position; refer to [Using the Speed-range Control \(page 27\)](#).
- Check the fluid level in the reservoir for the speed control cylinder (Figure 71).

Note: The normal fluid level is between the Min and Max marks on the side of the reservoir.

- If the fluid level is low, perform the following:
 - Wipe clean the area around the cap for the reservoir (Figure 71).
 - Remove the cap from the reservoir (Figure 71).
 - Add the specified fluid to raise the level midway between the Min and Max marks on the side of the reservoir (Figure 71).
 - Install the cap hand tight (Figure 71).
- Align the holes in the control-cover plate to the holes in the seat base (Figure 70).
- Secure the plate to the base with the 6 hex-washer screws (Figure 70) that you removed in step 2.
- Thread the knobs onto the rods for the hydraulic-lift lever and the speed-range lever (Figure 70).

Adjusting the Speed Control

Important: The minimum controlled speed for the machine is 4.0 kph (2.5 mph) at full engine speed. Controlling the machine speed slower than 4.0 kph (2.5 mph) will result in excessive belt and clutch wear.

- Drive the machine in speed range A (low range), B (mid-low range), C (mid-high range), or D (high range) in order to determine which speed range includes the maximum-ground speed that you want to set; refer to .
- Remove the knobs from the hydraulic-lift lever and the speed-range lever (Figure 70).
- Remove the 6 hex-washer screws (#10 x 3/4 inch) that secure the control-cover plate to the seat base, and remove the cover plate (Figure 70).
- Move the speed-range lever to the **T** (transport) position (Figure 72).

- Loosen the 2 hex-socket screws (5/16 x 3/4 inch) that secure the detent plate to the lever-support bracket (Figure 72).

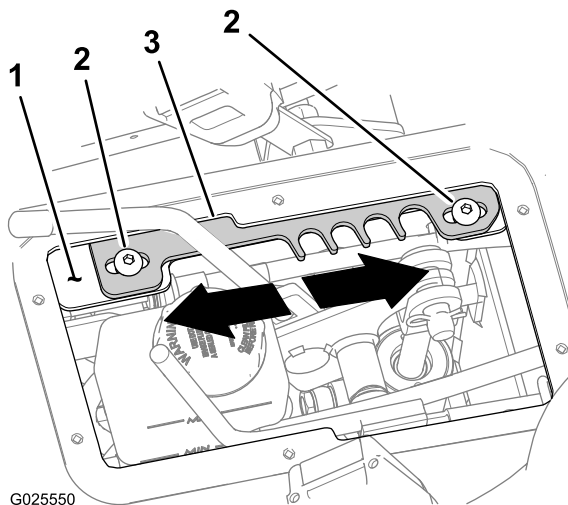

Figure 72

- | | |
|--------------------------|-----------------|
| 1. Lever-support bracket | 3. Detent plate |
| 2. Hex-socket screws | |

- Move the detent plate in one of the following directions:
 - Move the detent plate **forward** to increase the maximum ground speed limit (Figure 72).
 - Move the detent plate **rearward** to decrease the maximum ground speed limit (Figure 72).
- Tighten the 2 hex-socket screws (5/16 x 3/4 inch) to 1978 to 2542 N-cm (175 to 225 in-lb).
- Drive the machine with the speed control set to speed range for which you are setting the maximum ground speed limit. If the maximum ground speed limit is too fast or too slow, repeat steps 1 through 8 until the correct maximum ground speed limit is attained.
- Align the holes in the control-cover plate to the holes in the seat base (Figure 70).
- Secure the plate to the base with the 6 hex-washer screws (Figure 70) that you removed in step 3.
- Thread the knobs onto the rods for the hydraulic-lift lever and the speed-range lever (Figure 70).

Checking the Drive Belt

Service Interval: Every 400 hours

- Remove the 9 hex-washer bolts (1/4 x 1 inch) that secure the transmission cover to the mounting plate of the transmission (Figure 73).

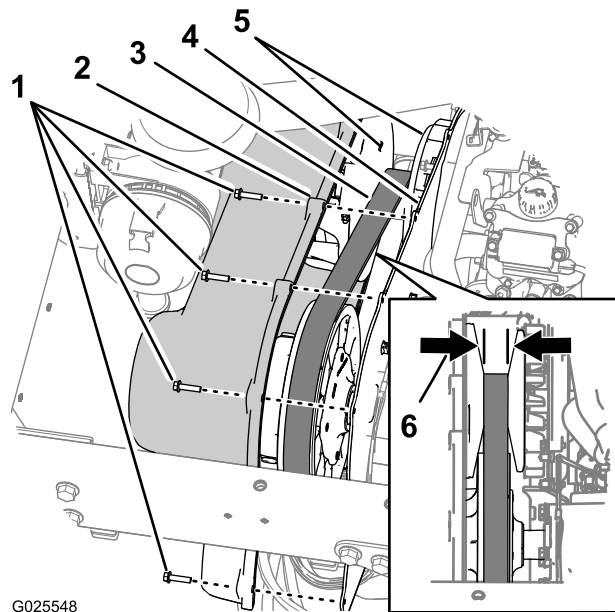

Figure 73

- | | |
|------------------------------------|--|
| 1. Hex-washer bolts (1/4 x 1 inch) | 4. Mounting plate |
| 2. Transmission cover | 5. Tapered faces (primary clutch) |
| 3. Drive belt | 6. Belt width—replace at 29.5 mm (1.16 inch) or less |

- Move the cover forward until you can see the drive belt (Figure 73).
- Check the tapered faces of the primary clutch for signs of damage (Figure 73).

Note: If the faces of the primary clutch are damaged, replace the primary clutch; contact your Authorized Service Dealer or Authorized Distributor.

- Check the drive belt for missing or damaged cogs (Figure 73).

Note: If the cogs of the drive belt are missing or damaged, replace the drive belt.

- Measure across the belt and record the belt width (Figure 73).

Note: If the width of the belt is 29.5 mm (1.16 inch) or less, replace the belt (Figure 73).

- Align the holes in the transmission cover with the holes in the mounting plate (Figure 73).
- Secure the cover to the mounting plate (Figure 73) with the 9 hex-washer bolts (1/4 x 1 inch) that you removed

in step 1, and torque the bolts to 10.2 to 12.4 N-m (90 to 110 in-lb).

Cleaning the Clutches

Service Interval: Every 400 hours

1. Remove the 9 hex-washer bolts (1/4 x 1 inch) that secure the transmission cover to the mounting plate of the transmission (Figure 74).

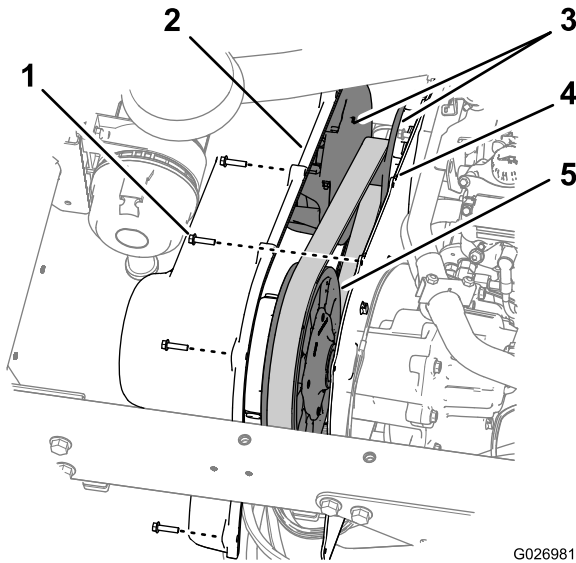

Figure 74

G026981

- | | |
|------------------------------------|---------------------|
| 1. Hex-washer bolts (1/4 x 1 inch) | 4. Mounting plate |
| 2. Transmission cover | 5. Secondary clutch |
| 3. Primary clutch | |

2. At the primary and secondary clutches, Remove dirt and mud buildup with water and dry immediately with compressed air to remove excess water and debris.
3. Remove any remaining debris using a fast-drying contact cleaner or brake cleaner.

Note: Note: Remove the debris in and around moving parts.

4. If debris or buildup exists around the belt or along the clutch shaft, use a fine abrasive pad or a similar product to remove it.
5. Align the holes in the transmission cover with the holes in the mounting plate (Figure 74).
6. Secure the cover to the mounting plate (Figure 74) with the 9 hex-washer bolts (1/4 x 1 inch) that you removed in step 1, and torque the bolts to 10.2 to 12.4 N-m (90 to 110 in-lb).

Maintaining the Differential and Axles

Changing the Differential Oil

Oil type: 80W90 API GL-5

Oil capacity: 550 ml (18.6 oz)

1. Align a drain pan under the drain plug (Figure 75).

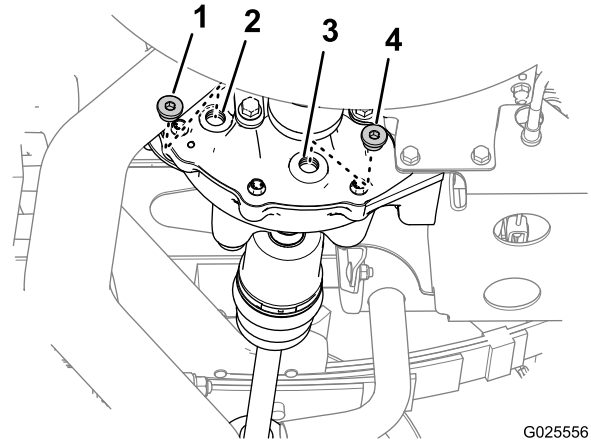

G025556

Figure 75

- | | |
|--------------|---------------|
| 1. Fill plug | 3. Drain port |
| 2. Fill port | 4. Drain plug |

2. Remove the fill plug from the fill port and the drain plug from the drain port of the differential (Figure 75).

Note: Allow the differential to completely drain.

3. Check the condition of the O-rings on the plugs.

Note: Replace damaged or worn O-rings.

4. Install the drain plug into the drain port (Figure 75), and tight the plug to 14 to 19 N-m (10 to 14 ft-lb).

Note: The drain plug is magnetic. It is normal to see small amounts of ferrous-metal particles around magnet—expect more particles around the magnet after initial break-in.

5. Add 550 ml (18.6 oz) of the specified oil into the fill port of the differential (Figure 75).

Note: Use a funnel with a flexible hose to add oil to the differential.

6. Install the fill plug into the fill port (Figure 75), and tighten the plug to 14 to 19 N-m (10 to 14 ft-lb).

Checking the Constant Velocity Boots

Service Interval: Every 100 hours

1. Jack up the back end of the machine and support it with jack stands; refer to [Jacking the Machine \(page 37\)](#).
2. Check the CV (constant velocity) boots at the rear axles for damage and leaking lubricant ([Figure 76](#)).

Note: Replace any damaged or leaking CV boot before operating the machine.

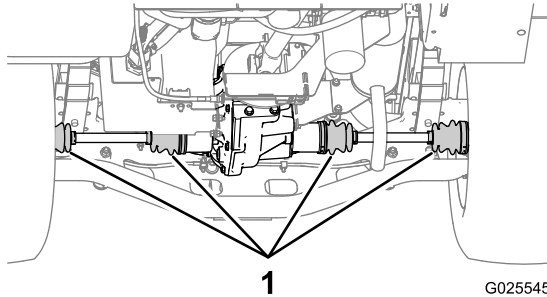

1
Figure 76

G025545

3. Remove the jack stands and lower the machine to the ground.

Cooling System Maintenance

Changing the Engine Coolant

Service Interval: Every 1,000 hours/Every 2 years
(whichever comes first)

Cooling system capacity: 3.7 L (4 qt)

Coolant type: a 50/50 solution of water and permanent ethylene glycol antifreeze

1. Park the machine on a level surface.
2. Raise the bed (if so equipped) and install the bed safety support on the extended lift cylinder to hold up the bed; refer to [Raising the Cargo Box \(page 19\)](#) and [Using the Bed Safety Support \(page 36\)](#).

CAUTION

If the engine has been running, the cooling system will pressurize with hot coolant that can escape and cause burns.

- Do not open the radiator cap when the engine is running.
- Allow the engine to cool for at least 15 minutes or until the radiator cap is cool enough to touch without burning your hand.
- Use a rag to open the radiator cap. Open the cap slowly to allow the steam to escape.

3. Remove the radiator cap ([Figure 77](#)).

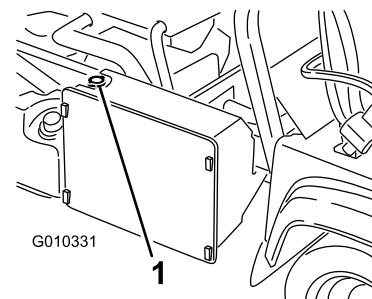

1
Figure 77

1. Radiator cap

4. Remove the cap from the coolant reserve tank ([Figure 77](#)).

Brake Maintenance

Adjusting the Parking Brake

Service Interval: After the first 10 hours

Every 200 hours

1. Remove the rubber grip from the parking-brake lever (Figure 79).

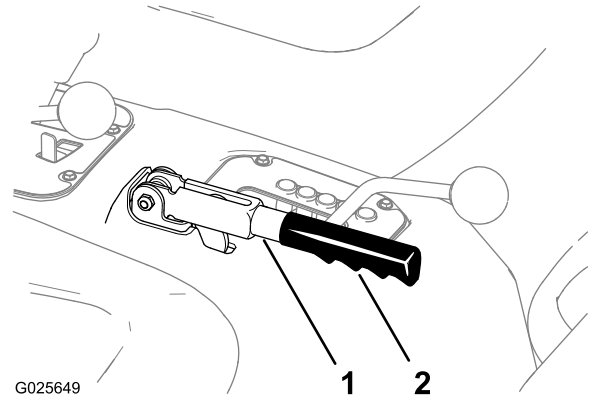

Figure 79

1. Parking-brake lever
2. Grip

2. Loosen the set screw securing the knob to the parking-brake lever (Figure 80).

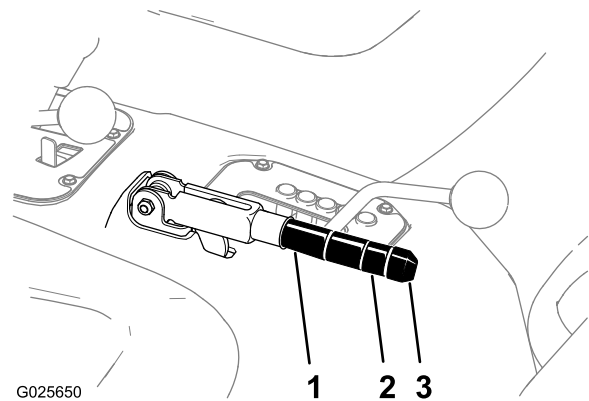

Figure 80

1. Parking-brake lever
2. Knob
3. Set screw

3. Rotate the knob (Figure 80) until a force of 20 to 22 kg (45 to 50 lb) is required to actuate the lever.
4. Tighten the set screw when finished (Figure 80).

Note: If you can no longer make a parking-brake adjustment by adjusting parking-the brake lever, loosen the handle to the middle of the adjustment and adjust the cable at the rear, then repeat step 3.

5. Install the rubber grip onto the parking-brake lever (Figure 79).

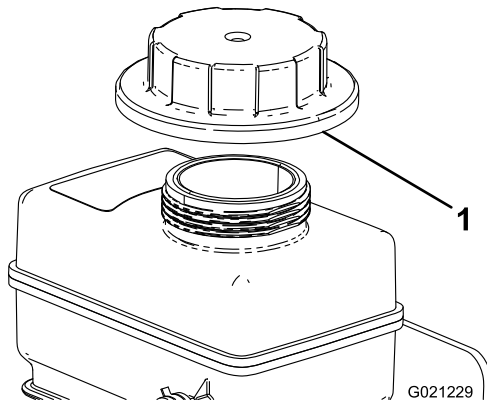

Figure 78

1. Cap (coolant-reserve tank)

5. Disconnect the lower radiator hose and allow the coolant to flow into a drain pan.

Note: When the coolant stops flowing, connect the lower radiator hose.

6. Slowly fill the radiator with a 50/50 mixture of water and permanent ethylene glycol anti-freeze
7. Top off the radiator and install the cap (Figure 77).
8. Slowly fill the coolant-reserve tank until level reaches the bottom of the filler neck (Figure 78).
9. Install the cap on the coolant-reserve tank (Figure 78).
10. Start the engine and operate it until it is warm.
11. Stop the engine, check the coolant level, and replenish the coolant if required.

Adjusting the Brake Pedal

Service Interval: Every 200 hours

1. Remove the hood; refer to [Removing the Hood \(page 38\)](#).
2. Remove the cotter pin and clevis pin securing the master-cylinder yoke to the brake pedal pivot ([Figure 81](#)).

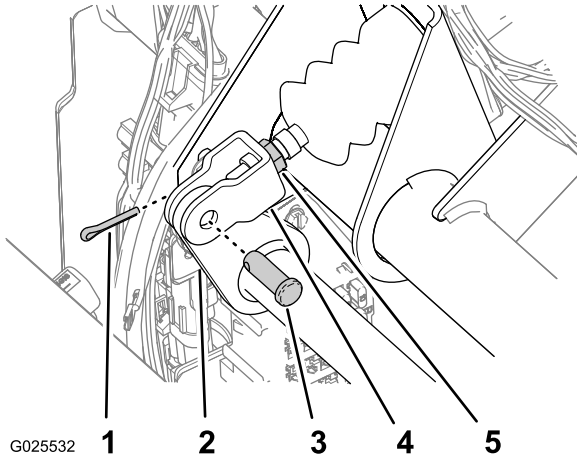

Figure 81

- | | |
|----------------------|-------------------------|
| 1. Cotter pin | 4. Master-cylinder yoke |
| 2. Brake pedal pivot | 5. Jam nut |
| 3. Clevis pin | |

3. Lift up on the brake pedal ([Figure 82](#)) until it contacts the frame.

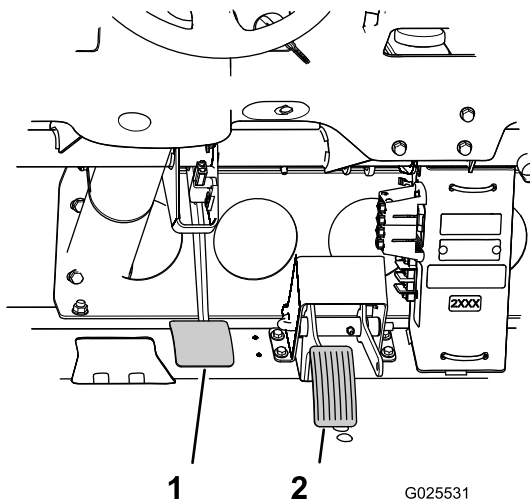

Figure 82

- | | |
|----------------|----------------------|
| 1. Brake pedal | 2. Accelerator pedal |
|----------------|----------------------|

4. Loosen the jam nuts securing the yoke to the master cylinder shaft ([Figure 81](#)).
5. Adjust the yoke until its holes align with the hole in the brake pedal pivot ([Figure 81](#)).
6. Secure the yoke to the pedal pivot with the clevis pin and cotter pin ([Figure 81](#)).

7. Tighten the jam nut securing the yoke to the master cylinder shaft ([Figure 81](#)).

Note: The brake-master cylinder must relieve the pressure from the service brake when it is properly adjusted.

8. Install the hood; refer to [Removing the Hood \(page 38\)](#).

Controls System Maintenance

Converting the Speedometer

You can convert the speedometer from mph to kpm or kph to mph.

1. Position the machine on a level surface, stop the engine, engage the parking brake, and remove the key from the ignition switch.
2. Remove the hood; refer to [Removing the Hood \(page 38\)](#).
3. Locate the 2 loose wires next to the speedometer ([Figure 83](#)).

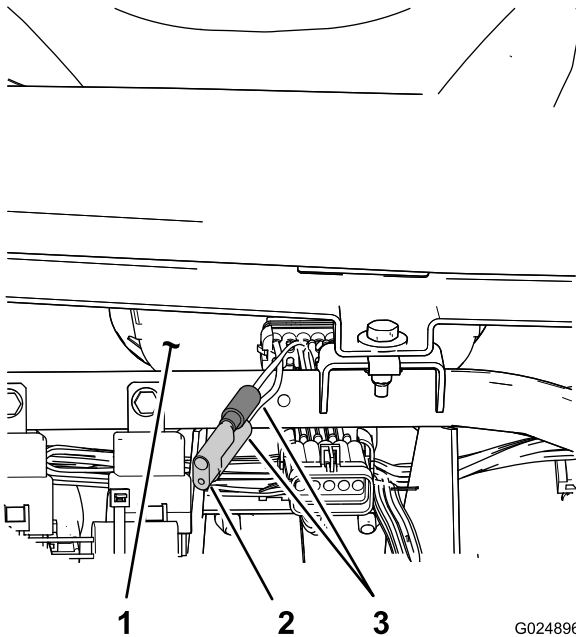

1. Speedometer (forward face)
2. Plug
3. Speedometer wires

4. Remove the connector plug from the harness wire and connect the wires together ([Figure 83](#)).

Note: The speedometer will switch from mph to kph. Retain the plug in order to convert the speedometer to mph.

5. Install the hood; refer to [Installing the Hood \(page 38\)](#).

Adjusting the Accelerator Pedal

Adjusting the Slow Idle for the Engine

1. Start the engine and run it until the engine is at normal operating temperature (approximately 5–10 minutes).
2. Ensure that the throttle is set to slow idle and check the tachometer to see if the engine running at 1100 rpm (low idle).

Note: If the slow-engine idle speed is 1100 rpm, skip to [Adjusting the Fast Idle for the Engine \(page 54\)](#).

3. If the engine low-idle rpm is faster or slower than 1100 rpm, rotate the idle screw clockwise or counterclockwise at the throttle body for the engine until the engine idle speed is 1100 rpm ([Figure 84](#)).

Note: The fan must not run while setting the engine idle speed.

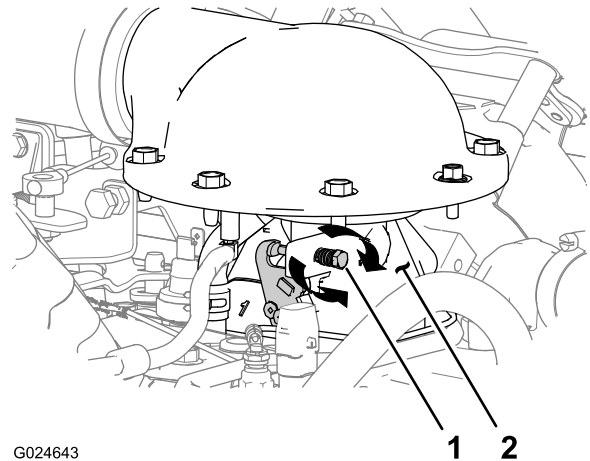

1. Idle screw
2. Throttle body

Adjusting the Fast Idle for the Engine

1. Start the engine and run it until the engine is at normal operating temperature (approximately 5–10 minutes).
2. With your hand, move the bellcrank for the throttle against the fast-idle stop ([Figure 85](#)).

Note: The engine speed displayed on the tachometer should read 3600 rpm.

Note: If the fast-engine idle speed is 3600 rpm, skip to [Adjusting the Accelerator Pedal Position \(page 55\)](#).

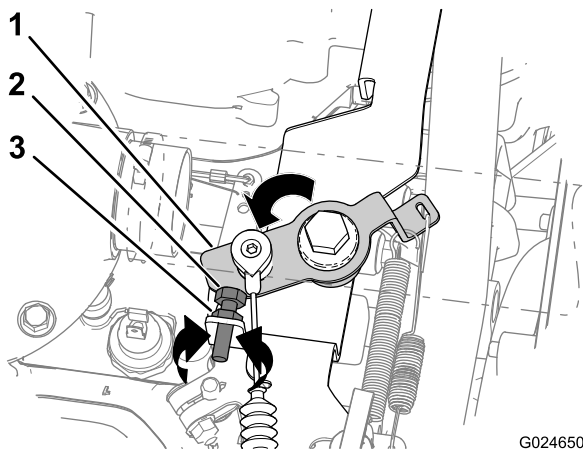

Figure 85

- | | |
|-------------------|------------|
| 1. Bellcrank | 3. Jam nut |
| 2. Fast-idle stop | |

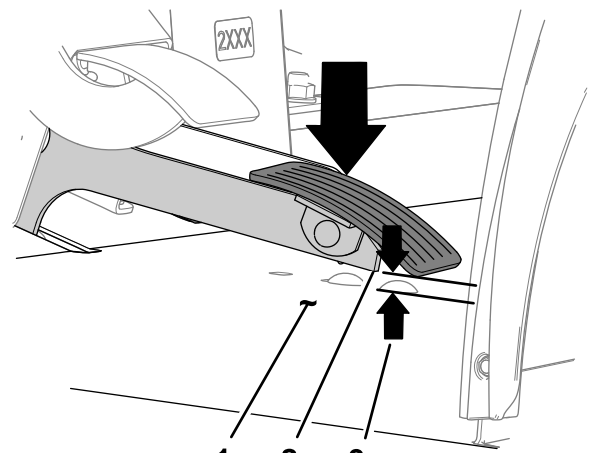

Figure 86

- | | |
|----------------------|---------------------------|
| 1. Floor | 3. 6.35 mm (1/4 inch) gap |
| 2. Accelerator pedal | |

3. If the fast-idle speed for the engine is faster or slower than 3600 rpm, perform the following:
 - A. Loosen the jam nut that secures the fast-idle stop (Figure 85).
 - B. Rotate the stop in the following directions:
 - Clockwise to decrease the engine rpm (Figure 85).
 - Counterclockwise to increase the engine rpm (Figure 85).
 - C. Tighten the jam nut (Figure 85).
 - D. Move the bellcrank against the fast-idle stop (Figure 85).
 - E. If the engine high idle rpm is faster or slower 3600 rpm, repeat steps A through D until the fast-idle speed is 3600 rpm.
4. Shut off the engine and remove the key from the ignition switch.

3. If the gap between the accelerator pedal and the floor (Figure 86) is larger than or smaller than 6.35 mm (1/4 inch), perform the following while holding the bellcrank against the fast-idle stop (Figure 85):
 - Loosen the inboard-jam nut for the throttle cable and tighten the outboard jam nut to decrease the gap (Figure 87).
 - Loosen the outboard-jam nut for the throttle cable and tighten the inboard jam nut to increase the gap (Figure 87).

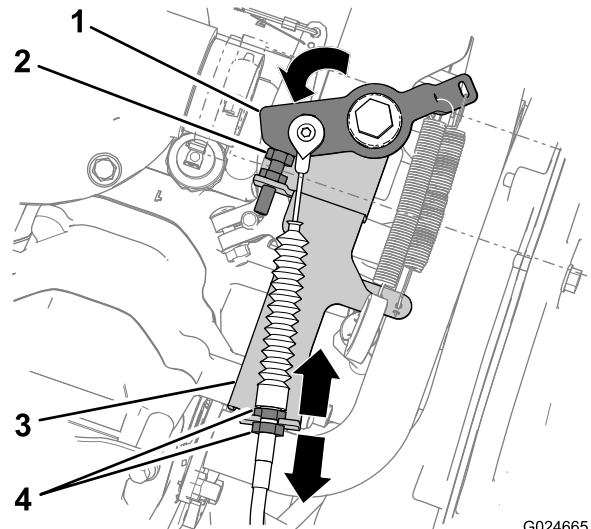

Figure 87

- | | |
|-------------------|---------------------|
| 1. Bellcrank | 3. Throttle bracket |
| 2. Fast-idle stop | 4. Jam nut |

4. Ensure that the jam nuts for the throttle cable are tight (Figure 87).
5. Hold the bellcrank against the fast-idle stop and check the gap between the accelerator pedal and the floor. If the gap is larger than or smaller than 6.35 mm (1/4

Adjusting the Accelerator Pedal Position

Use another person to help adjust the accelerator pedal.

1. Move the bellcrank against the fast-idle stop and hold it against the stop (Figure 85).
2. Measure the gap between the accelerator pedal and the floor beneath the pedal (Figure 86).

Note: The gap between the accelerator pedal and the floor should measure 6.35 mm (1/4 inch).

Note: If the gap between the accelerator pedal and the floor is 6.35 mm (1/4 inch), skip to [Adjusting the Accelerator Pedal Upstop](#) (page 56).

inch), repeat steps 3 and 4 until you measure a 6.35 mm (1/4 inch) gap between the pedal and the floor.

Adjusting the Accelerator Pedal Upstop

1. With the accelerator pedal up, measure the distance from the rearward-bottom corner of the accelerator-pedal arm to the floor (Figure 88).

Note: Write down this measurement (measurement 1).

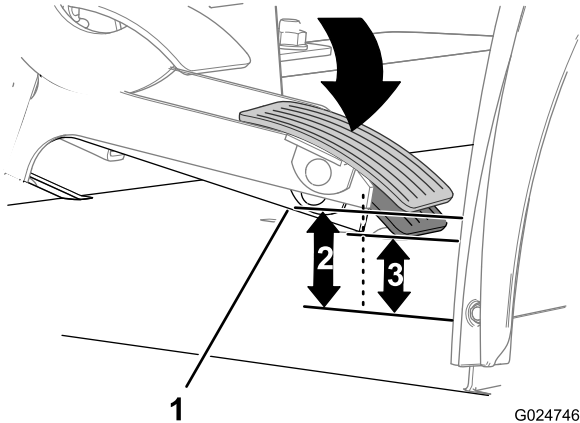

Figure 88

1. Accelerator-pedal arm
2. Measurement 1
3. Measurement 2

2. Gently move the throttle pedal down until the free play is removed from between the accelerator pedal and the throttle cable (Figure 88).

3. While holding the pedal in position to remove the free play, measure the distance from the rearward bottom corner of the accelerator-pedal arm to the floor (Figure 88).

Note: Write down this measurement (measurement 2).

4. Subtract measurement 2 from measurement 1; the result is the **pedal-free travel**.

Note: The pedal-free travel should measure 3 mm (0.125 inch).

5. If the pedal-free travel is larger than or smaller than 3 mm (0.125 inch), perform the following:

- A. Loosen the jam nut that secures the accelerator-pedal stop (Figure 89).
- B. Rotate the accelerator-pedal stop in the following directions:
 - Clockwise to increase the pedal-free travel (Figure 89).
 - Counterclockwise to decrease the pedal-free travel (Figure 89).

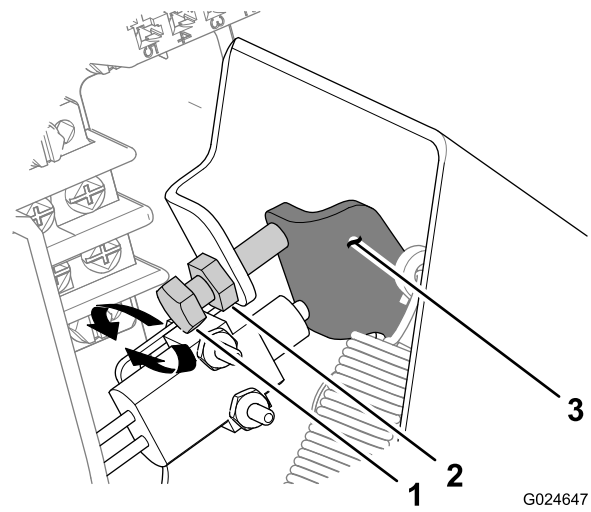

Figure 89

1. Accelerator-pedal stop
2. Jam nut
3. Flange of the accelerator-pedal arm

- C. Tighten the jam nut (Figure 89).

- D. Repeat steps 1 through 4 to measure the pedal-free travel (Figure 89).

Note: The pedal-free travel should measure 3 mm (0.125 inch).

- E. Repeat steps A through D until the pedal-free travel is 3 mm (0.125 inch).

Hydraulic System Maintenance

Replacing the Hydraulic Filter

Service Interval: After the first 10 hours

Every 800 hours

Important: Use of any other filter may void the warranty on some components.

1. Position the vehicle on a level surface, stop the engine, engage the parking brake, and remove the key from ignition switch.
2. Clean the area around filter mounting area (Figure 90).

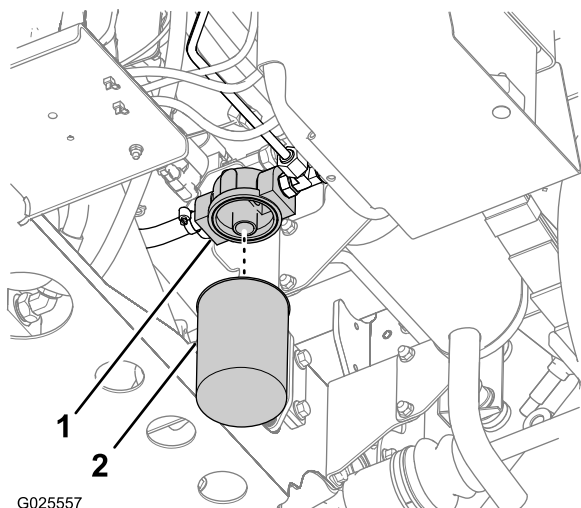

Figure 90

1. Filter adapter
2. Hydraulic filter

3. Place a drain pan under the filter (Figure 90).
4. Remove the filter by rotating it counterclockwise (Figure 90).
5. Clean the filter-seating surface of the filter adapter (Figure 90).
6. Lubricate the gasket on the new filter with the specified Mobil M15 hydraulic fluid.
7. Thread the filter onto the filter adapter until the gasket of the filter contacts the seating surface of the adapter (Figure 90), and then tighten the filter an additional 1/2 turn (Figure 90).
8. Start the engine and let it run for about 2 minutes to purge air from the system.
9. Stop the engine and check the hydraulic oil level in the reservoir and the filter area for leaks.

Changing the Hydraulic Fluid

Service Interval: Every 800 hours

Hydraulic Fluid Type: Mobil M15

Hydraulic Fluid Capacity: (Non-TC model): 7.5 L (2 US gallons)

Hydraulic Fluid Capacity: (Non-TC model with the High Flow Hydraulic Kit (option) or TC model): 15.1 L (4 US gallons)

1. Position the vehicle on a level surface, stop the engine, engage the parking brake, and remove the key from the ignition switch.
2. Raise the cargo box, refer to [Raising the Cargo Box](#) (page 19).
3. Remove the cap and dipstick from the filler neck of the reservoir (Figure 91).

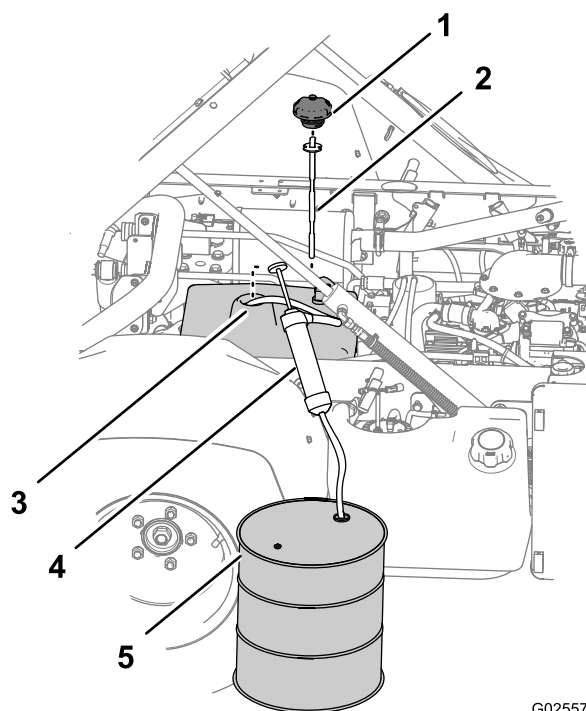

Figure 91

1. Cap
2. Dipstick
3. Filler neck (hydraulic reservoir)
4. Siphon equipment
5. Collection container

4. Route the intake hose of the siphoning equipment through the filler neck of the hydraulic reservoir and to the bottom of the reservoir (Figure 91).
5. Direct the discharge hose of the siphoning equipment into a collection container (Figure 91) with a 11.4 L (3 US gallon) capacity—Non-TC model or 18.9 L (5 US gallon) capacity—Non-TC model with the High Flow Hydraulic Kit (option) or TC model.
6. Siphon the hydraulic fluid from the reservoir.

7. Remove the siphoning equipment from the reservoir (Figure 91).
8. Add 7.5 L (2 US gallons)—Non-TC model or 15.1 L (4 US gallons)—Non-TC model with the High Flow Hydraulic Kit (option) or TC model of the specified hydraulic fluid into the hydraulic reservoir (Figure 91).

Important: Use only the hydraulic fluids specified. Other fluids could cause system damage.

9. Install the dipstick and cap to the filler neck of the hydraulic reservoir (Figure 91).
10. Start the engine and operate the vehicle to fill the hydraulic system. Check the hydraulic oil level and replenish it, if required.

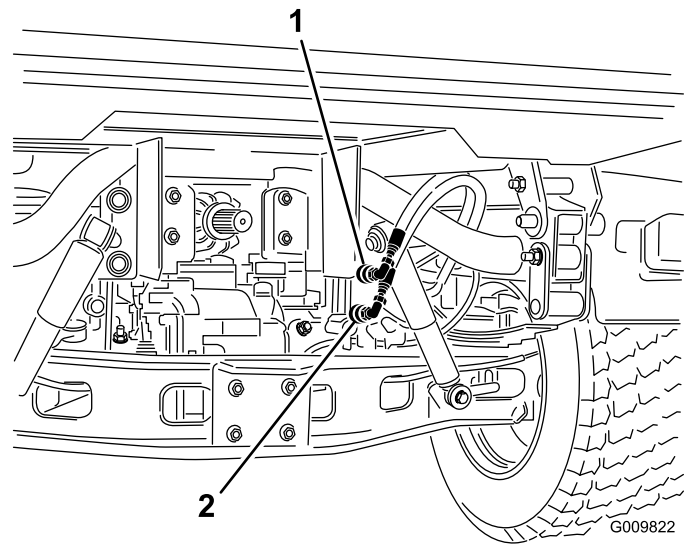

Figure 92

1. Quick coupler hose A
2. Quick coupler hose B

Raising the Box in an Emergency

You can raise the box in an emergency without starting the engine by cranking starter or by jumping hydraulic system.

Raising the Box Using the Starter

Note: If the engine will not crank, you must remove the load and box (attachment) in order to service the engine.

1. Ensure that the transmission lever is in the **P** (park) position; refer to [Transmission Lever \(page 15\)](#).
2. Crank the starter while holding the lift lever in the Raise position.

Note: Run the starter for 15 seconds then wait 60 seconds before engaging the starter again.

Raising the Box by Jumping the Hydraulic System

Note: This procedure requires 2 hydraulic hoses, each with a male and a female quick coupler, that fits the couplers on the vehicle.

1. Back another vehicle up to the rear of the disabled vehicle.

Important: The hydraulic system uses Mobil M15. To avoid system contamination, make sure that the vehicle you use to jump the hydraulic system uses an equivalent fluid.

2. On both vehicles, disconnect the 2 quick coupler hoses from the hoses secured to the coupler bracket (Figure 92).

3. On the disabled vehicle, connect the 2 jumper hoses to the hoses that were disconnected (Figure 93).

Note: Cap the unused fittings.

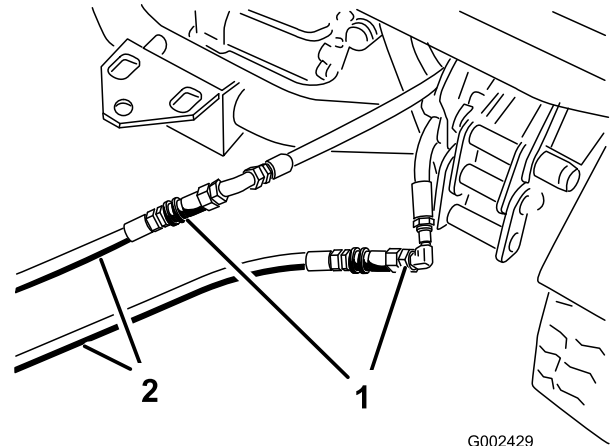

Figure 93

1. Disconnected hoses
2. Jumper hoses

4. On the other vehicle, connect the 2 hoses to the coupler still in the coupler bracket (connect the top hose to the top coupler and the bottom hose to the bottom coupler) (Figure 94).

Note: Cap the unused fittings.

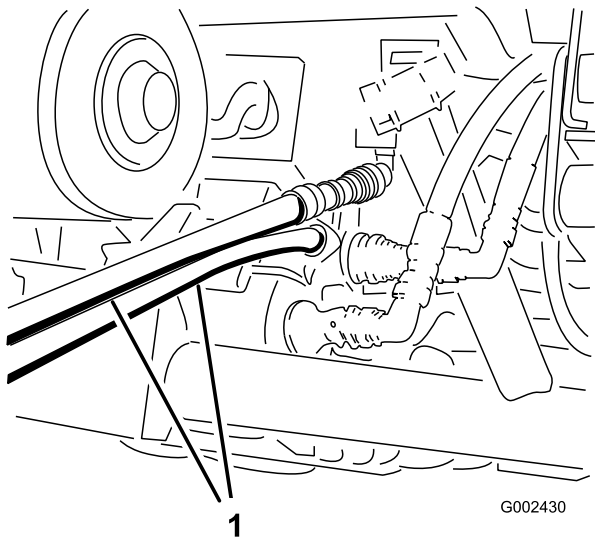

Figure 94

1. Jumper hoses

5. Keep all bystanders away from the vehicles.
6. Start the second vehicle and move the lift lever to the raise position which will raise the disabled box.
7. Move the hydraulic lift lever to the neutral position and set the hydraulic-lift lock; refer to [Hydraulic Lift Lever \(page 16\)](#).
8. Install the bed safety support onto the extended lift cylinder; refer to [Using the Bed Safety Support \(page 36\)](#).

Note: With both the vehicles turned off, move the lift lever back and forth to remove the system pressure and ease the disconnection of the quick couplers.

9. After completing the operation, remove the jumper hoses and connect the hydraulic hoses to both vehicles.

Important: Check the hydraulic fluid levels in both vehicles before resuming operation.

Storage

1. Position the machine on a level surface, set the parking brake, stop the engine, and remove the ignition key.
2. Clean dirt and grime from the entire machine, including the outside of the engine cylinder head fins and blower housing.

Important: You can wash the machine with mild detergent and water. Do not use high-pressure water to wash the machine. Pressure washing the machine may damage the electrical system or wash away necessary grease at friction points. Avoid excessive use of water, especially near the control panel, lights, engine, and battery.

3. Inspect the brakes; refer to [Checking the Brake Fluid \(page 24\)](#).
4. Service the air cleaner; refer to [Servicing the Air Filter \(page 40\)](#).
5. Grease the machine.
6. Change the engine oil; refer to [Changing the Engine Oil and Filter \(page 41\)](#).
7. Check the tire pressure; refer to [Checking the Tire Pressure \(page 26\)](#).
8. For storage over 30 days, prepare the fuel system as follows:

- A. Add a petroleum based stabilizer/conditioner to the fuel in the tank.

Follow mixing instructions from the stabilizer manufacturer. (1 oz per US gallon). Do not use an alcohol based stabilizer (ethanol or methanol).

Note: A fuel stabilizer/conditioner is most effective when mixed with fresh gasoline and the stabilizer/conditioner is used at all times.

- B. Run the engine to distribute conditioned fuel through the fuel system for 5 minutes.
- C. Stop the engine, allow it to cool, and drain the fuel tank.
- D. Start the engine and run it until it stops.
- E. Start and run the engine again until it will not start again.
- F. Dispose of drained fuel properly. Recycle as per local codes.

Important: Do not store stabilizer/conditioned gasoline for over 90 days.

9. Remove the spark plugs and check their condition; refer to [Replacing the Spark Plug \(page 42\)](#).
10. With the spark plugs removed from the engine, pour 2 tablespoons of engine oil into the spark plug hole.
11. Use the starter to crank the engine and distribute the oil inside the cylinder.

12. Install the spark plugs and tighten each one to the recommended torque; refer to [Replacing the Spark Plug \(page 42\)](#).

Note: Do not install the spark-plug wires on the spark plugs.

13. Check the anti freeze protection and add a 50/50 solution of water and anti freeze as needed for expected minimum temperature in your area.
14. Remove the battery from the chassis, and charge it fully; refer to [Servicing the Battery \(page 45\)](#).

Note: Do not connect the battery cables to the battery posts during storage.

Important: The battery must be fully charged to prevent it from freezing and being damaged at temperatures below 0°C (32°F). A fully charged battery maintains its charge for about 50 days at temperatures lower than 4°C (40°F). If the temperatures will be above 4°C (40°F), check the water level in the battery and charge it every 30 days.

15. Check and tighten all the bolts, nuts, and screws. Repair or replace any part that is damaged.
16. Paint all the scratched or bare metal surfaces.
Note: Paint is available from your Authorized Service Distributor.
17. Store the machine in a clean, dry garage or storage area.
18. Remove the ignition key and put it in a safe place that is out of the reach of children.
19. Cover the machine to protect it and keep it clean.

Troubleshooting

Problem	Possible Cause	Corrective Action
The quick couplers are difficult to connector disconnect.	1. The hydraulic pressure not relieved (the quick coupler is under pressure).	1. Shut off the engine, move the hydraulic-lift lever forward and backward several times, and connect the quick couplers for the fittings in the auxiliary hydraulic panel.
The power steering moves hard.	1. The hydraulic oil level is low. 2. The hydraulic oil is hot. 3. The hydraulic pump not operating.	1. Service the hydraulic reservoir. 2. Check the hydraulic oil level and service if it is low. Contact you Authorized Service Dealer. 3. Contact you Authorized Service Dealer.
The hydraulic fitting leaks.	1. The fitting is loose. 2. The hydraulic fitting is missing an O-ring.	1. Tighten the fitting. 2. Install the missing O-ring.
An attachment does not function.	1. The quick couplers are not fully connected. 2. The quick couplers are interchanged.	1. Disconnect the quick couplings, remove and debris from the couplings, connect the couplings. Replace any damaged couplings. 2. Disconnect the quick couplings, align the couplings to the correct ports on the auxiliary hydraulic panel, connect the couplings.
A squealing noise is heard.	1. The Hydraulic-lift lever is locked in the On position (causing hydraulic oil to flow over the relief valve).	1. Set the hydraulic-lift lock to the Unlock position and move the hydraulic-lift lever to Neutral.
The engine will not start.	1. The hydraulic-lift lever is locked in the On position.	1. Set the hydraulic-lift lock to the Unlock position, move the hydraulic-lift lever to Neutral, and start the engine.
The transmission is hard to shift	1. The engine idle rpm is set too fast. 2. The clutched are dirty.	1. Adjust the engine slow idle to 1100 rpm; refer to Adjusting the Slow Idle for the Engine. 2. Clean the clutches; refer to Cleaning the Clutches.
The clutch engagement is abrupt.	1. The engine idle is too slow. 2. The belt is new. 3. The accelerator pedal free play is too large. 4. The clutched are dirty.	1. Adjust the engine slow idle to 1100 rpm; refer to Adjusting the Slow Idle for the Engine. 2. Allow 10 hours of normal operation for the belt break-in period. 3. Adjust the accelerator pedal; refer to Adjusting the Accelerator Pedal. 4. Clean the clutches; refer to Cleaning the Clutches.

Notes:

International Distributor List

Distributor:	Country:	Phone Number:	Distributor:	Country:	Phone Number:
Agrolanc Kft	Hungary	36 27 539 640	Maquiver S.A.	Colombia	57 1 236 4079
Balama Prima Engineering Equip.	Hong Kong	852 2155 2163	Maruyama Mfg. Co. Inc.	Japan	81 3 3252 2285
B-Ray Corporation	Korea	82 32 551 2076	Mountfield a.s.	Czech Republic	420 255 704 220
Casco Sales Company	Puerto Rico	787 788 8383	Mountfield a.s.	Slovakia	420 255 704 220
Ceres S.A.	Costa Rica	506 239 1138	Munditol S.A.	Argentina	54 11 4 821 9999
CSSC Turf Equipment (pvt) Ltd.	Sri Lanka	94 11 2746100	Norma Garden	Russia	7 495 411 61 20
Cyril Johnston & Co.	Northern Ireland	44 2890 813 121	Oslinger Turf Equipment SA	Ecuador	593 4 239 6970
Cyril Johnston & Co.	Republic of Ireland	44 2890 813 121	Oy Hako Ground and Garden Ab	Finland	358 987 00733
Equiver	Mexico	52 55 539 95444	Parkland Products Ltd.	New Zealand	64 3 34 93760
Femco S.A.	Guatemala	502 442 3277	Perfetto	Poland	48 61 8 208 416
ForGarder OU	Estonia	372 384 6060	Pratoverde SRL.	Italy	39 049 9128 128
G.Y.K. Company Ltd.	Japan	81 726 325 861	Prochaska & Cie	Austria	43 1 278 5100
Geomechaniki of Athens	Greece	30 10 935 0054	RT Cohen 2004 Ltd.	Israel	972 986 17979
Golf international Turizm	Turkey	90 216 336 5993	Riversa	Spain	34 9 52 83 7500
Guandong Golden Star	China	86 20 876 51338	Lely Turfcare	Denmark	45 66 109 200
Hako Ground and Garden	Sweden	46 35 10 0000	Solvart S.A.S.	France	33 1 30 81 77 00
Hako Ground and Garden	Norway	47 22 90 7760	Spypros Stavrinides Limited	Cyprus	357 22 434131
Hayter Limited (U.K.)	United Kingdom	44 1279 723 444	Surge Systems India Limited	India	91 1 292299901
Hydroturf Int. Co Dubai	United Arab Emirates	97 14 347 9479	T-Markt Logistics Ltd.	Hungary	36 26 525 500
Hydroturf Egypt LLC	Egypt	202 519 4308	Toro Australia	Australia	61 3 9580 7355
Irrimac	Portugal	351 21 238 8260	Toro Europe NV	Belgium	32 14 562 960
Irrigation Products Int'l Pvt Ltd.	India	0091 44 2449 4387	Valtech	Morocco	212 5 3766 3636
Jean Heybroek b.v.	Netherlands	31 30 639 4611	Victus Emak	Poland	48 61 823 8369

European Privacy Notice

The Information Toro Collects

Toro Warranty Company (Toro) respects your privacy. In order to process your warranty claim and contact you in the event of a product recall, we ask you to share certain personal information with us, either directly or through your local Toro company or dealer.

The Toro warranty system is hosted on servers located within the United States where privacy law may not provide the same protection as applies in your country.

BY SHARING YOUR PERSONAL INFORMATION WITH US, YOU ARE CONSENTING TO THE PROCESSING OF YOUR PERSONAL INFORMATION AS DESCRIBED IN THIS PRIVACY NOTICE.

The Way Toro Uses Information

Toro may use your personal information to process warranty claims, to contact you in the event of a product recall and for any other purpose which we tell you about. Toro may share your information with Toro's affiliates, dealers or other business partners in connection with any of these activities. We will not sell your personal information to any other company. We reserve the right to disclose personal information in order to comply with applicable laws and with requests by the appropriate authorities, to operate our systems properly or for our own protection or that of other users.

Retention of your Personal Information

We will keep your personal information as long as we need it for the purposes for which it was originally collected or for other legitimate purposes (such as regulatory compliance), or as required by applicable law.

Toro's Commitment to Security of Your Personal Information

We take reasonable precautions in order to protect the security of your personal information. We also take steps to maintain the accuracy and current status of personal information.

Access and Correction of your Personal Information

If you would like to review or correct your personal information, please contact us by email at legal@toro.com.

Australian Consumer Law

Australian customers will find details relating to the Australian Consumer Law either inside the box or at your local Toro Dealer.



Toro General Commercial Product Warranty

A Two-Year Limited Warranty

Conditions and Products Covered

The Toro Company and its affiliate, Toro Warranty Company, pursuant to an agreement between them, jointly warrant your Toro Commercial product ("Product") to be free from defects in materials or workmanship for two years or 1500 operational hours*, whichever occurs first. This warranty is applicable to all products with the exception of Aerators (refer to separate warranty statements for these products). Where a warrantable condition exists, we will repair the Product at no cost to you including diagnostics, labor, parts, and transportation. This warranty begins on the date the Product is delivered to the original retail purchaser.

* Product equipped with an hour meter.

Instructions for Obtaining Warranty Service

You are responsible for notifying the Commercial Products Distributor or Authorized Commercial Products Dealer from whom you purchased the Product as soon as you believe a warrantable condition exists. If you need help locating a Commercial Products Distributor or Authorized Dealer, or if you have questions regarding your warranty rights or responsibilities, you may contact us at:

Toro Commercial Products Service Department
Toro Warranty Company
8111 Lyndale Avenue South
Bloomington, MN 55420-1196
952-888-8801 or 800-952-2740
E-mail: commercial.warranty@toro.com

Owner Responsibilities

As the Product owner, you are responsible for required maintenance and adjustments stated in your *Operator's Manual*. Failure to perform required maintenance and adjustments can be grounds for disallowing a warranty claim.

Items and Conditions Not Covered

Not all product failures or malfunctions that occur during the warranty period are defects in materials or workmanship. This warranty does not cover the following:

- Product failures which result from the use of non-Toro replacement parts, or from installation and use of add-on, or modified non-Toro branded accessories and products. A separate warranty may be provided by the manufacturer of these items.
- Product failures which result from failure to perform recommended maintenance and/or adjustments. Failure to properly maintain your Toro product per the Recommended Maintenance listed in the *Operator's Manual* can result in claims for warranty being denied.
- Product failures which result from operating the Product in an abusive, negligent, or reckless manner.
- Parts subject to consumption through use unless found to be defective. Examples of parts which are consumed, or used up, during normal Product operation include, but are not limited to, brake pads and linings, clutch linings, blades, reels, rollers and bearings (sealed or greasable), bed knives, spark plugs, castor wheels and bearings, tires, filters, belts, and certain sprayer components such as diaphragms, nozzles, and check valves, etc.
- Failures caused by outside influence. Conditions considered to be outside influence include, but are not limited to, weather, storage practices, contamination, use of unapproved fuels, coolants, lubricants, additives, fertilizers, water, or chemicals, etc.
- Failure or performance issues due to the use of fuels (e.g. gasoline, diesel, or biodiesel) that do not conform to their respective industry standards.

Countries Other than the United States or Canada

Customers who have purchased Toro products exported from the United States or Canada should contact their Toro Distributor (Dealer) to obtain guarantee policies for your country, province, or state. If for any reason you are dissatisfied with your Distributor's service or have difficulty obtaining guarantee information, contact the Toro importer.

- Normal noise, vibration, wear and tear, and deterioration.
- Normal "wear and tear" includes, but is not limited to, damage to seats due to wear or abrasion, worn painted surfaces, scratched decals or windows, etc.

Parts

Parts scheduled for replacement as required maintenance are warranted for the period of time up to the scheduled replacement time for that part. Parts replaced under this warranty are covered for the duration of the original product warranty and become the property of Toro. Toro will make the final decision whether to repair any existing part or assembly or replace it. Toro may use remanufactured parts for warranty repairs.

Deep Cycle and Lithium-Ion Battery Warranty:

Deep cycle and Lithium-Ion batteries have a specified total number of kilowatt-hours they can deliver during their lifetime. Operating, recharging, and maintenance techniques can extend or reduce total battery life. As the batteries in this product are consumed, the amount of useful work between charging intervals will slowly decrease until the battery is completely worn out. Replacement of worn out batteries, due to normal consumption, is the responsibility of the product owner. Battery replacement may be required during the normal product warranty period at owner's expense. Note: (Lithium-Ion battery only): A Lithium-Ion battery has a part only prorated warranty beginning year 3 through year 5 based on the time in service and kilowatt hours used. Refer to the *Operator's Manual* for additional information.

Maintenance is at Owner's Expense

Engine tune-up, lubrication, cleaning and polishing, replacement of filters, coolant, and completing recommended maintenance are some of the normal services Toro products require that are at the owner's expense.

General Conditions

Repair by an Authorized Toro Distributor or Dealer is your sole remedy under this warranty.

Neither The Toro Company nor Toro Warranty Company is liable for indirect, incidental or consequential damages in connection with the use of the Toro Products covered by this warranty, including any cost or expense of providing substitute equipment or service during reasonable periods of malfunction or non-use pending completion of repairs under this warranty. Except for the Emissions warranty referenced below, if applicable, there is no other express warranty. All implied warranties of merchantability and fitness for use are limited to the duration of this express warranty.

Some states do not allow exclusions of incidental or consequential damages, or limitations on how long an implied warranty lasts, so the above exclusions and limitations may not apply to you. This warranty gives you specific legal rights, and you may also have other rights which vary from state to state.

Note regarding engine warranty:

The Emissions Control System on your Product may be covered by a separate warranty meeting requirements established by the U.S. Environmental Protection Agency (EPA) and/or the California Air Resources Board (CARB). The hour limitations set forth above do not apply to the Emissions Control System Warranty. Refer to the Engine Emission Control Warranty Statement supplied with your product or contained in the engine manufacturer's documentation for details