



**Count on it.**

**Operator's Manual**

# MMX-650E-S or MMX-850E-S Mortar Mixer

Model No. 60212—Serial No. 315000001 and Up

Model No. 60218—Serial No. 315000001 and Up

Model No. 60219—Serial No. 315000001 and Up

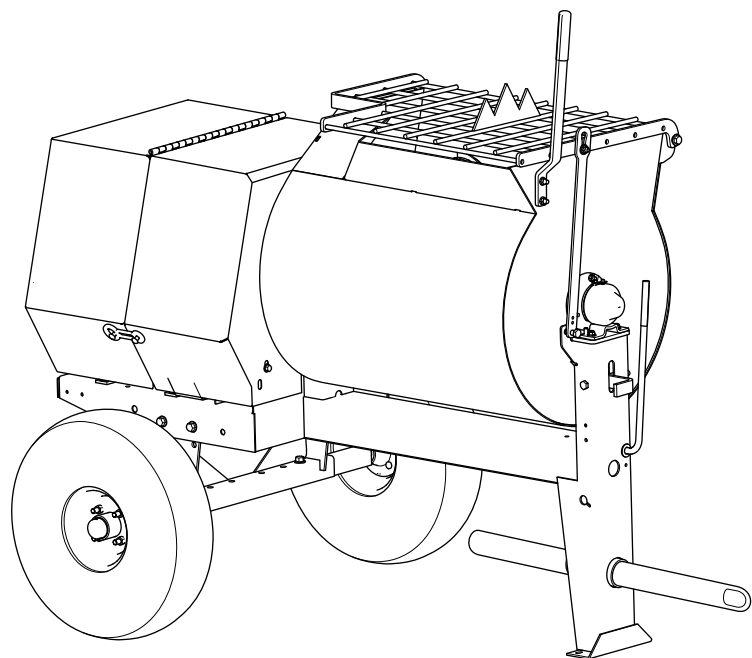

G028568



**▲ WARNING**

**CALIFORNIA  
Proposition 65 Warning**

**This product contains a chemical or chemicals known to the State of California to cause cancer, birth defects, or reproductive harm.**

**Use of this product may cause exposure to chemicals known to the State of California to cause cancer, birth defects, or other reproductive harm.**

# Introduction

This machine is designed to mix mortar, plaster, fireproofing material, grout, and other small-grained cement products. A vehicle equipped with an appropriate pintle hitch or ball hitch can tow the machine.

Read this information carefully to learn how to operate and maintain your product properly and to avoid injury and product damage. You are responsible for operating the product properly and safely.

You may contact Toro directly at [www.Toro.com](http://www.Toro.com) for product safety and operation training materials, accessory information, help finding a dealer, or to register your product.

Whenever you need service, genuine Toro parts, or additional information, contact an Authorized Service Dealer or Toro Customer Service and have the model and serial numbers of your product ready. Write the numbers in the space provided.

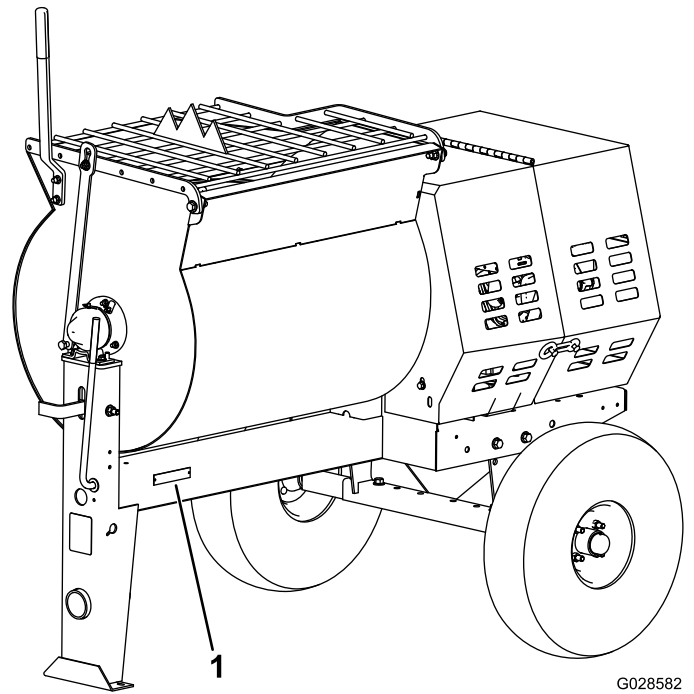

**Figure 1**

1. Model and serial number location

<b>Model No.</b> _____
<b>Serial No.</b> _____

This manual identifies potential hazards and has safety messages identified by the safety alert symbol (Figure 2), which signals a hazard that may cause serious injury or death if you do not follow the recommended precautions.



**Figure 2**

1. Safety alert symbol

This manual uses 2 words to highlight information.

**Important** calls attention to special mechanical information and **Note** emphasizes general information worthy of special attention.

The DOT tire information is located on the side of each tire. This information gives load and speed ratings. Replacement tires should have the same or better ratings.

**Note:** The various machines in this manual have different weights; refer to [Specifications \(page 11\)](#) to ensure that the tires on your machine meet or exceed the weight requirements of your machine.

# Contents

Safety .....	3
Safe Operating Practices .....	3
Safety and Instructional Decals .....	6
Setup .....	7
1 Installing the Dump Handle .....	7
2 Installing the Tow Pole .....	7
3 Installing the Safety Chain .....	8
4 Adjusting the Mixing Paddles .....	9
Product Overview .....	9
Controls .....	10
Specifications .....	11
Operation .....	12
Preparing to Tow the Machine .....	12
Extending the Axle .....	15
Towing the Machine .....	16
Preparing to Use the Machine .....	16
Opening and Closing the Cowl .....	17
Powering the Machine .....	17
Starting and Stopping the Motor .....	19
Controlling the Paddles .....	19
Mixing the Material .....	19
Using the Drum .....	20
Maintenance .....	22
Recommended Maintenance Schedule(s) .....	22
Premaintenance Procedures .....	22
Preparing the Machine for Maintenance .....	22
Removing and Installing the Divider Plate .....	22
Lubrication .....	23
Lubricating the Bearings and Seals .....	23
Lubricating the Motor Bearings .....	24
Lubricating the Drive Chain .....	24
Belt Maintenance .....	25
Servicing the Belts .....	25
Replacing the Belts .....	26
Aligning the Pulleys .....	28
Drive Chain Maintenance .....	28
Checking and Adjusting the Drive Chain .....	28
Paddle Maintenance .....	29
Adjusting the Paddles .....	29
Cleaning .....	31
Cleaning the Machine .....	31
Storage .....	32
Storing the Machine .....	32
Troubleshooting .....	33
Schematics .....	34

# Safety

Improperly using or maintaining the machine can result in injury. To reduce the potential for injury, comply with these safety instructions and always pay attention to the safety alert symbol **▲**, which means: *Caution, Warning, or Danger*—personal safety instruction. Failure to comply with the instruction may result in personal injury or death.

## Safe Operating Practices

This product is capable of amputating hands. Always follow all safety instructions to avoid serious injury or death.

### **▲ WARNING**

**Machining or handling stone, masonry, concrete, metal, and other materials can generate dust, mists, and fumes containing chemicals, such as silica, known to cause serious or fatal injury or illness, such as respiratory disease, silicosis, cancer, birth defects, or other reproductive harm.**

- **Control dust, mist, and fumes at the source where possible. Water should be used for dust suppression when feasible.**
- **Use good work practices and follow the recommendations of the manufacturer or suppliers, OSHA, and other occupational and trade associations.**
- **Always follow respiratory precautions.**
- **When the hazards from inhalation cannot be eliminated, the operator and any bystanders should wear a respirator approved by OSHA for the material being handled.**

## Training

- Read the *Operator's Manual* and other training material. If the operator(s) or mechanic(s) cannot read or understand the information, it is the owner's responsibility to explain this material to them.
- Become familiar with the safe operation of the equipment, operator controls, and safety signs.
- All operators and mechanics should be trained. The owner is responsible for training the users.
- Never let children or untrained people operate or service the equipment. Local regulations may restrict the age of the operator.
- The owner/user can prevent and is responsible for accidents or injuries to people or damage to property.

## Towing

Check with your local county or state towing safety regulations before towing the machine.

- In order to reduce the possibility of an accident while transporting the machine on public roads, make sure the towing vehicle is mechanically sound and in good operating condition.
- Turn off the motor before transporting the machine.
- When towing with a ball hitch, ensure that the ball hitch you are using is the proper size for the hitch coupler on the machine.
- When towing with a pintle hitch, ensure that the eye of the tow pole is the correct dimension for the pintle hook.
- Inspect the hitch and coupling for wear. **Never** tow the machine with damaged or defective hitches, couplings, chains, or other components.
- Check the tire air pressure on the towing vehicle and the machine.
- Check the tire tread and sidewall for damage and wear.
- Properly attach the safety chains to the towing vehicle.
- Ensure that the directional and brake lights are working properly (if the machine is equipped with the light kit).
- Ensure that the directional, backup, and brake lights of the tow vehicle are working properly.
- Before towing, check to make certain your machine is correctly and securely attached to the towing vehicle.
- Ensure that the safety chains are properly secured to the vehicle, and leave enough slack for turning.
- Do not carry any material in the machine when towing.
- Avoid sudden stops and starts. This can cause skidding, or jackknifing. Smooth, gradual starts and stops will improve towing.
- Avoid sharp turns to prevent rolling. Tow only with a vehicle that has a hitch designed for towing. Do not attach towed equipment except at the hitch point.
- Do not tow the machine faster than 88 km/h (55 mph).
- Use caution when backing up; use a spotter outside the vehicle to guide you.
- Do not allow anyone to sit or ride on the machine.

## Preparation

Become familiar with the safe operation of the equipment, operator controls, and safety signs.

- Use only accessories and attachments approved by the manufacturer.
- Wear personal protective equipment and appropriate clothing including:
  - Hard hat
  - Respirator or dust mask
  - Face shield
  - Safety glasses

- Hearing protection
- Safety shoes
- Long pants
- Shirt with long sleeves that are tight at the wrists
- Tight-fitting gloves without drawstrings or loose cuffs
- Secure long hair, loose clothing, or jewelry that may get tangled in moving parts.
- Operating the equipment safely requires the full attention of the operator. Do not wear radio or music headphones while operating the machine.
- Ensure that the machine is on a level surface before operating the machine.
- Chock the tires of the machine to prevent unintended movement.
- Before every use:
  - Inspect the coupler, ball, and hitch.
  - Ensure that all lights are functioning properly (if the machine is equipped with a light kit).
  - Ensure that the tires are properly inflated as recommended.
  - Ensure that the lug nuts are tight and torqued properly.
  - Ensure that the machine is properly secured.

## Operation

- Never run the machine in a poorly ventilated or enclosed area without proper respiratory protection. Dust from materials being mixed can be very harmful to operators and bystanders.
- Only operate the machine in good lighting conditions.
- Before starting the machine, make sure that there are no persons or obstacles near or under the machine.
- Never leave a running machine unattended. Always stop the motor and verify that all moving parts have stopped.
- Chock the tires when using the machine.
- When not using the machine, chock the tires or keep it attached to the tow vehicle.
- Keep hands away from any moving parts. Keep feet away from the tires and the front post.
- Do not operate the machine outdoors in the rain.
- Do not operate the machine under the influence of alcohol or drugs.
- Ensure that the area is clear of other people or pets before operating the machine. Stop the machine if anyone enters the area.
- Never place your hands or any solid object into the drum when the machine is in operation.
- Do not touch parts which may be hot from operation. Allow them to cool before attempting to maintain, adjust, or service the machine.
- Never move the machine while the motor is running.

- Keep the cowl closed and latched during operation.
- Ensure that all the guards and shields are securely in place before operating the machine.
- Ensure that the ON/OFF switch is in the OFF position before connecting the machine to the electrical source.
- If the mixing paddles strike a foreign object or if the machine should start making an unusual noise or vibration, stop the motor and empty the drum. Wait for all moving parts to come to a complete stop and cool. Vibration is generally a warning of trouble. Inspect for clogging or damage. Clean and repair and/or replace damaged parts.
- Lightning can cause severe injury or death. If you see lightning or hear thunder in the area, do not operate the machine; seek shelter.

## Maintenance and Storage

- Before performing maintenance, do the following:
  - Park the machine on level ground.
  - Stop the motor. Wait for all movement to stop before adjusting, cleaning, or repairing.
  - Let the motor cool before performing maintenance or storing the machine.
  - Unplug the machine before making any repairs.
- Never lubricate, service, repair, or adjust the machine while it is running.
- Keep equipment materials clear from the motor.
- Never allow untrained personnel to service the machine.
- Keep hands, feet, and clothing away from moving parts. If possible, do not make adjustments with the motor running.
- Keep all parts in good working condition and all hardware tightened. Replace all worn or damaged decals.
- Remove any buildup of grease, oil, or debris from the machine.
- Do not modify the electrical connectors or wiring.
- Do not connect the ground circuit of the machine to the energized circuit of the electrical source.
- Do not tamper with safety devices.
- Chock the tires when storing the machine.
- Keep all nuts, bolts, screws, and hose clamps securely tightened. Keep equipment in good condition.
- To ensure optimum performance and continued safety certification of the machine, use only genuine Toro replacement parts and accessories. Replacement parts and accessories made by other manufacturers could be dangerous, and such use could void the product warranty..

# Safety and Instructional Decals



Safety decals and instructions are easily visible to the operator and are located near any area of potential danger. Replace any decal that is damaged or lost.

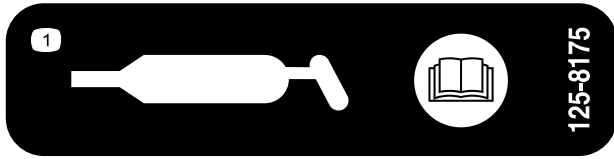

125-8175

1. Read the *Operator's Manual* for information on greasing the machine.

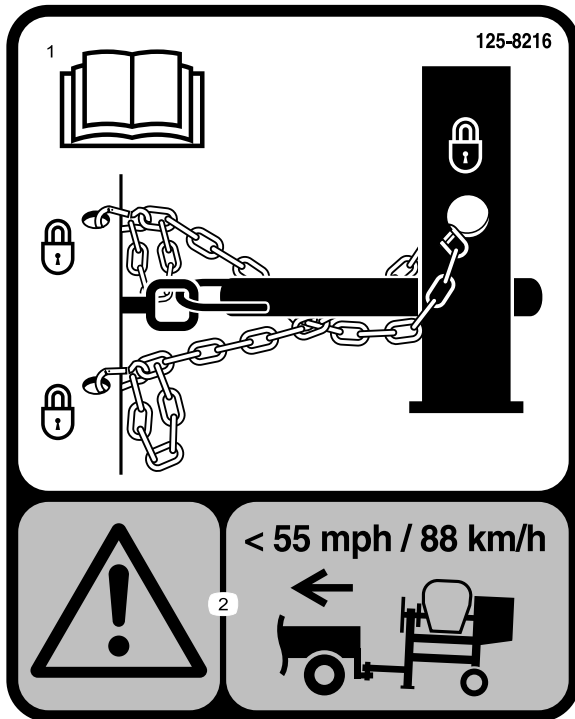

125-8216

1. Read the *Operator's Manual* for information on how to tow the machine.
2. Warning—limit towing speed to less than 55 mph / 88 km/h.

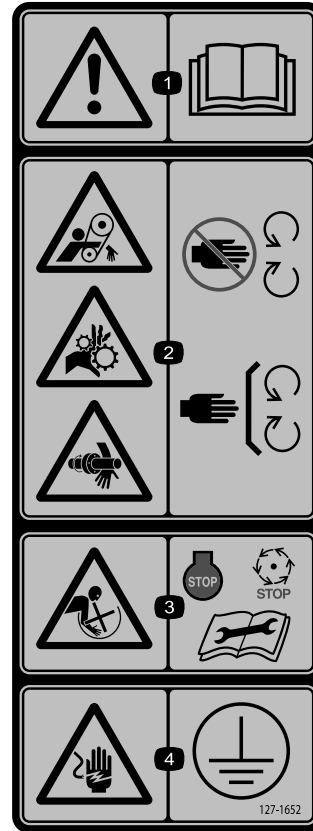

127-1652

1. Warning—read the *Operator's Manual*.
2. Hand and arm entanglement at the belt drive; crushing hazard of hand; entanglement hazard of hand at the shaft—keep hands away from moving parts; keep all guards and safeties in place.
3. Entanglement hazard at paddles—stop the motor and wait for all moving parts to stop before servicing the machine.
4. Shock hazard—make sure the machine is grounded before operation.

# Setup

## Loose Parts

Use the chart below to verify that all parts have been shipped.

Procedure	Description	Qty.	Use
<b>1</b>	Dump handle Bolt Nut	1 2 2	Install the dump handle.
<b>2</b>	Tow pole kit (sold separately)	1	Install the tow pole.
<b>3</b>	Safety chain (sold with optional tow pole kit) Connecting link (sold with optional tow pole kit)	1 2	Install the safety chain.
<b>4</b>	No parts required	–	Adjusting the mixing paddles.

# 1

## Installing the Dump Handle

Parts needed for this procedure:

1	Dump handle
2	Bolt
2	Nut

## Installing the Dump Handle to the Drum

1. Cut the cable ties to remove the dump handle from the underside of the grate.
2. Position the dump handle so that the bolt holes align with the bolt holes in the drum (Figure 3).

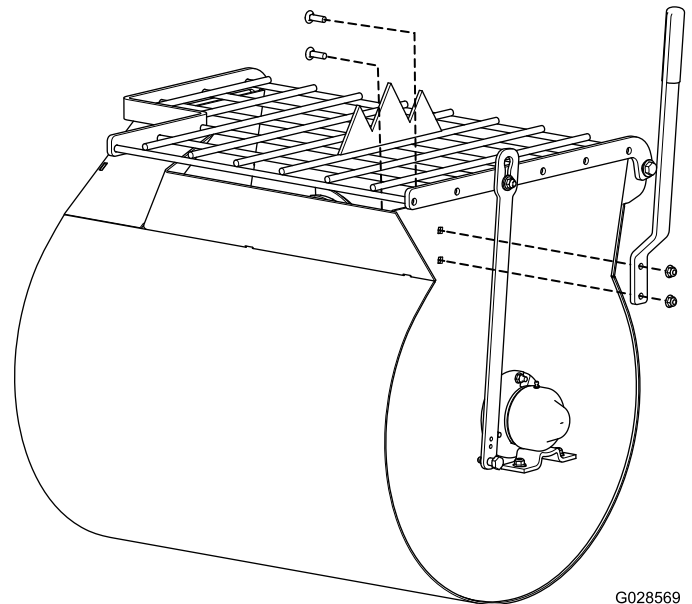

Figure 3

3. Insert 1 carriage bolt into the square bolt hole and slide the corresponding hole of the drum handle over it (Figure 3).
4. Install a nut onto the bolt, and tighten it.
5. Repeat the previous steps for the remaining carriage bolt.

# 2

## Installing the Tow Pole

Parts needed for this procedure:

1	Tow pole kit (sold separately)
---	--------------------------------

### Installing the Tow Pole to the Machine

**Note:** The tow pole is purchased separately and includes the nut and bolt needed for installation.

The machine has the following tow pole options:

Hitch Type	Length
50 mm (2 inch) ball—stamped	78.7 cm (31 inches)
50 mm (2 inch) ball—forged	78.7 cm (31 inches)
Pintle	78.7 cm (31 inches)

1. Remove the bolt and nut from the tow pole (Figure 4).

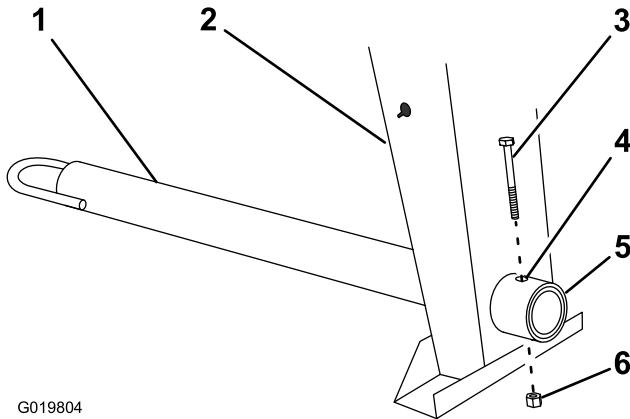

Figure 4

- |               |                  |
|---------------|------------------|
| 1. Tow pole   | 4. Bolt hole     |
| 2. Front post | 5. Frame fitting |
| 3. Bolt       | 6. Nut           |

2. Slide the tow pole forward and align the hole in the pole with the hole in the frame fitting (Figure 4).
3. Insert the bolt through the holes in the fitting and the pole (Figure 4).
4. Thread the nut onto the bolt and tighten them until they are tight against the frame fitting (Figure 4).

**Note:** If the self-locking nylon insert in the locknut wears with use, replace the nut with a new Grade 5 or Grade 8 locknut.

# 3

## Installing the Safety Chain

Parts needed for this procedure:

1	Safety chain (sold with optional tow pole kit)
2	Connecting link (sold with optional tow pole kit)

### Installing the Safety Chain

**Note:** The safety chain is part of the optional tow pole kit.

1. Form a hook on the end of a bendable piece of rod or stiff wire (not included), and insert it through both keyholes in the front post of the machine (Figure 5A).

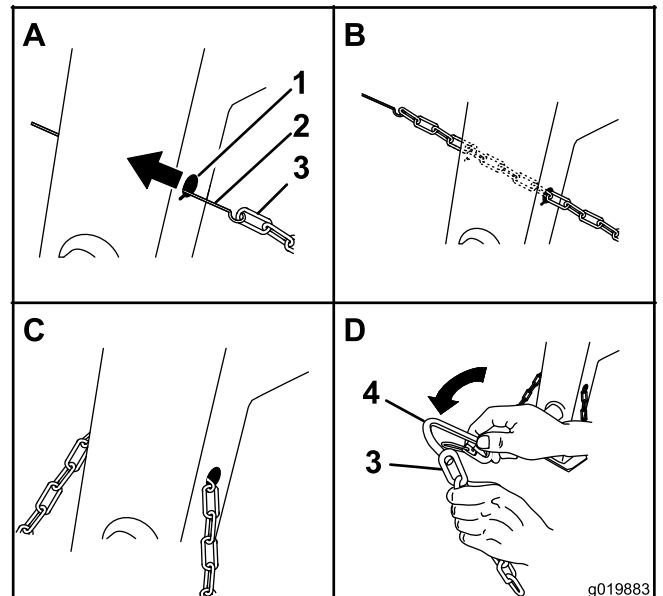

Figure 5

- |                               |                    |
|-------------------------------|--------------------|
| 1. Keyhole                    | 3. Safety chain    |
| 2. Rod or wire (not included) | 4. Connecting link |

2. Attach the safety chain to the length of rod or wire (Figure 5A).
3. Pull the rod, or wire, and the safety chain through both keyholes (Figure 5B).

**Note:** Ensure that approximately equal lengths of safety chain extend from either side of the front post.



## Installing the Connecting Links

**Note:** The connecting links are part of the optional tow pole kit.

1. Align the connecting link to the last link in one end of the safety chain ([Figure 5D](#)).
2. Insert the connecting link through the chain link until the connecting link snaps closed.
3. Repeat steps 1 and 2 to install the other connecting link in the other end of the safety chain.

# 4

## Adjusting the Mixing Paddles

**No Parts Required**

### Procedure

If the mixing paddles and wipers need adjustment, adjust the paddles and wipers; refer to [Adjusting the Paddles \(page 29\)](#).

## Product Overview

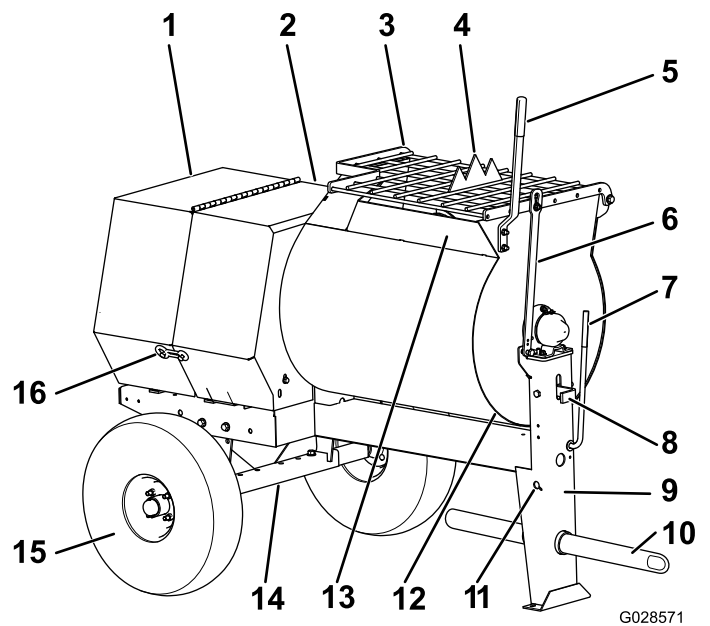

**Figure 6**

- |                   |                          |                    |
|-------------------|--------------------------|--------------------|
| 1. Rear cowl      | 7. Clutch lever          | 13. Chute          |
| 2. Front cowl     | 8. Dump latch            | 14. Axle           |
| 3. Grate          | 9. Front post            | 15. Wheel assembly |
| 4. Bag splitter   | 10. Tow pole             | 16. Cowl latch     |
| 5. Dump handle    | 11. Safety-chain keyhole |                    |
| 6. Grate lift arm | 12. Drum                 |                    |

# Controls

Become familiar with all the controls before you start the motor and operate the machine.

## Clutch Lever

The clutch lever is used to engage and disengage motor power to the paddles.

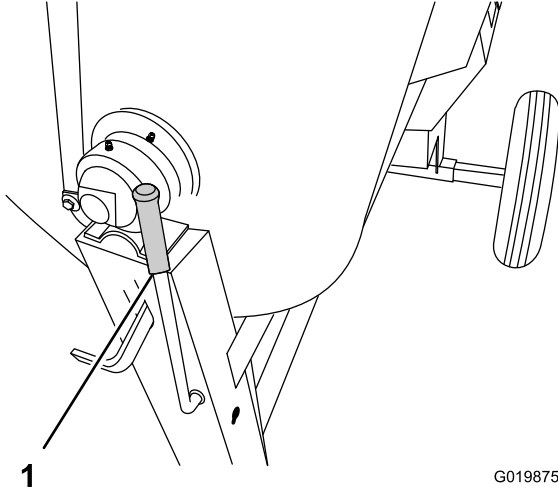

Figure 7

1. Clutch lever

## Dump Handle

Use the dump handle to rotate the drum to the dump position and to rotate the drum to the mix position (upright).

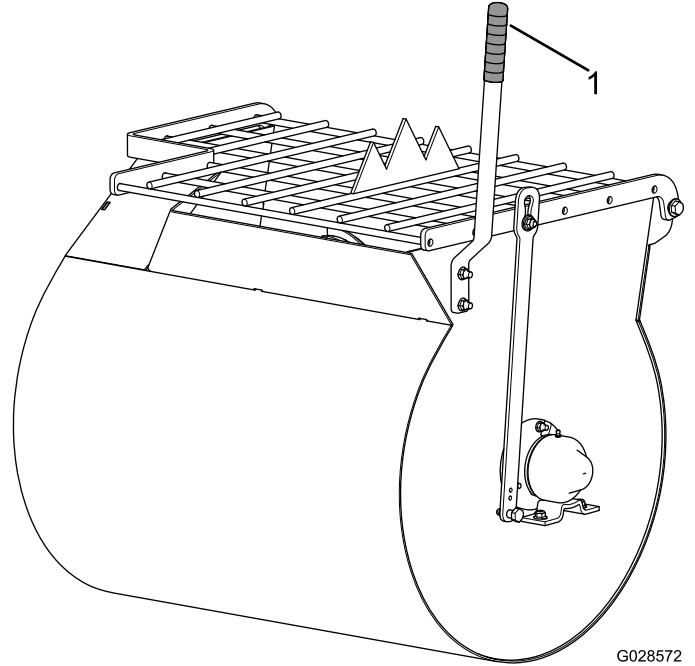

Figure 9

1. Dump handle

## Drum Latch

The drum latch secures the drum to the mix position (upright) for mixing operations and when transporting the machine.

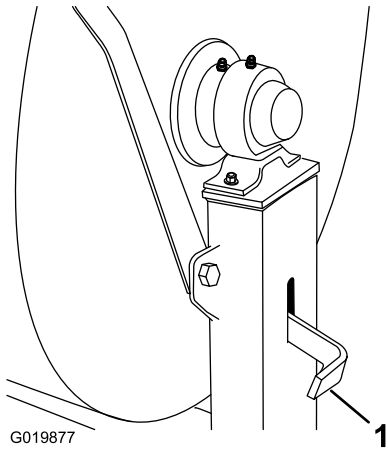

Figure 8

1. Drum latch

## Voltage Block

Use the voltage block to set the operating voltage for the machine (Figure 10).

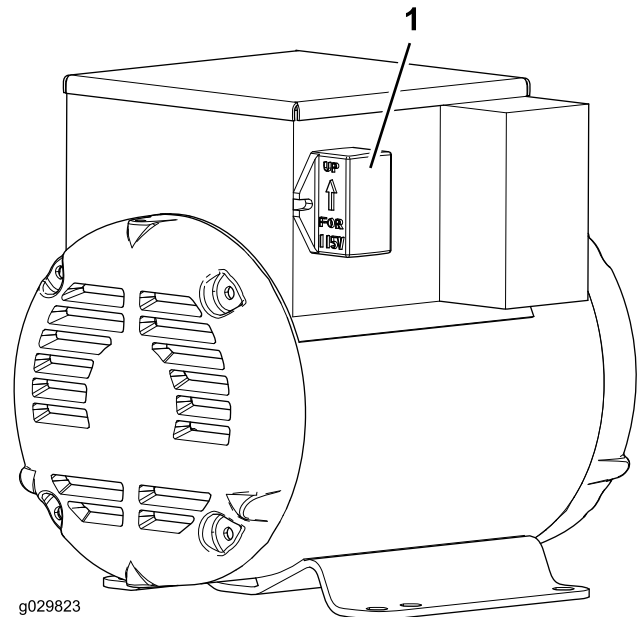
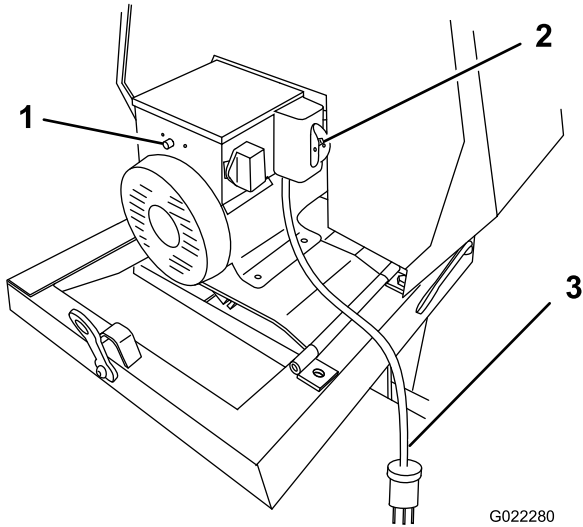

Figure 10

1. Voltage block

## Motor Controls

The following motor controls are found on all models:



**Figure 11**

1. Thermal-overload protector reset button
2. ON/OFF switch
3. Power cord

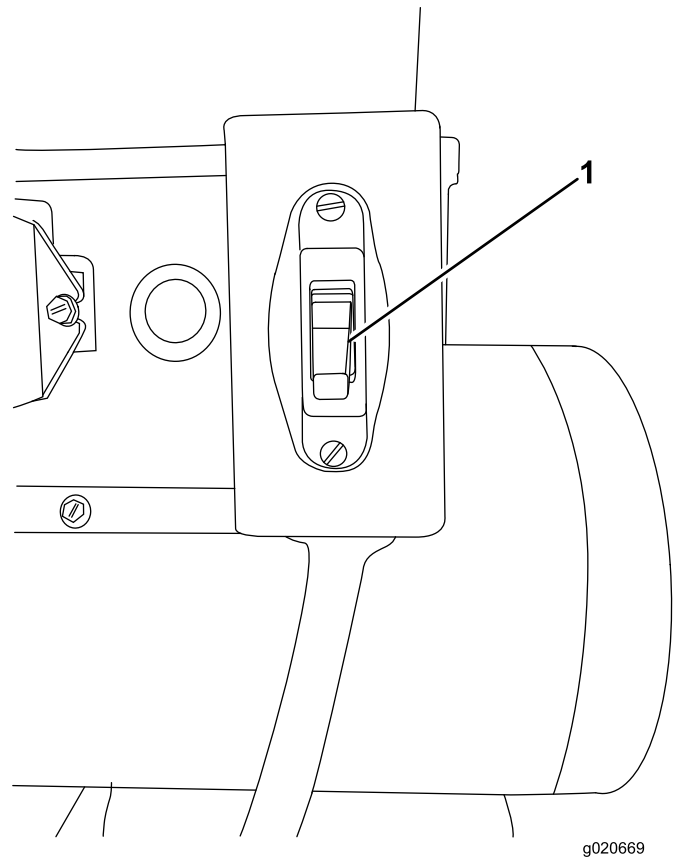

**Figure 12**

1. Motor ON/OFF switch

## Motor ON/OFF Switch

The ON/OFF switch (Figure 12) allows the operator of the machine to start and stop the motor. This switch is located on the front of the motor. It is marked (ON) and (OFF). Rotate the ON/OFF switch to the ON position to start and run the motor. Rotate the ON/OFF switch to the OFF position to stop the motor.

## Specifications

**Note:** Specifications and design are subject to change without notice.

### Machine Specifications

Model	60212	60218	60219
<b>Batch Capacity</b>	0.17 cubic m (6.0 cubic ft)	0.23 cubic m (8.0 cubic ft)	0.23 cubic m (8.0 cubic ft)
<b>Total Volume</b>	0.20 cubic m (7.1 cubic ft)	0.25 cubic m (9.0 cubic ft)	0.25 cubic m (9.0 cubic ft)
<b>Length</b> (without tow pole)	150 cm (59 inches)	168 cm (66 inches)	168 cm (66 inches)
<b>Width</b>	86 cm (34 inches)	86 cm (34 inches)	86 cm (34 inches)
<b>Height</b>	142 cm (56 inches)	142 cm (56 inches)	142 cm (56 inches)
<b>Weight</b>	250 kg (550 lb)	275 kg (605 lb)	275 kg (605 lb)
<b>Axle</b>	86 to 117 cm (34 to 46 inches) extendable	86 to 117 cm (34 to 46 inches) extendable	86 to 117 cm (34 to 46 inches) extendable
<b>Motor</b>	1.5 hp Baldor Electric	1.5 hp Baldor Electric	2 hp Baldor Electric

# Operation

**Important:** Before operating, remove any debris from the machine. Ensure that the area is clear of people.

## Preparing to Tow the Machine

**Important:** Ensure that your tow vehicle has towing capacity for the weight of the machine.

**Important:** Use a Class 2 or larger receiver.

**Note:** Ensure that your tow vehicle has the appropriate hitch to tow the machine; options include a 50 mm (2 inch) ball hitch or a pintle hitch.

**Note:** If the machine is equipped with a trailer-light kit, ensure that the electrical connector of the tow vehicle is compatible with the electrical connector of the machine. The machine uses a standard 4-flat plug. If your tow vehicle has a different type of plug, obtain an adapter from an automotive parts store.

1. Stop the motor, unplug the machine, and empty the drum.
2. If the drum has accumulated any water, dump the drum; refer to [Dumping the Drum \(page 20\)](#), steps 1, 3, 4, and 5.
3. Using the dump lever, position the drum so that it is in the mix position (upright) and locked.
4. Close the cowl and secure the cowl latches ([Figure 13](#)).

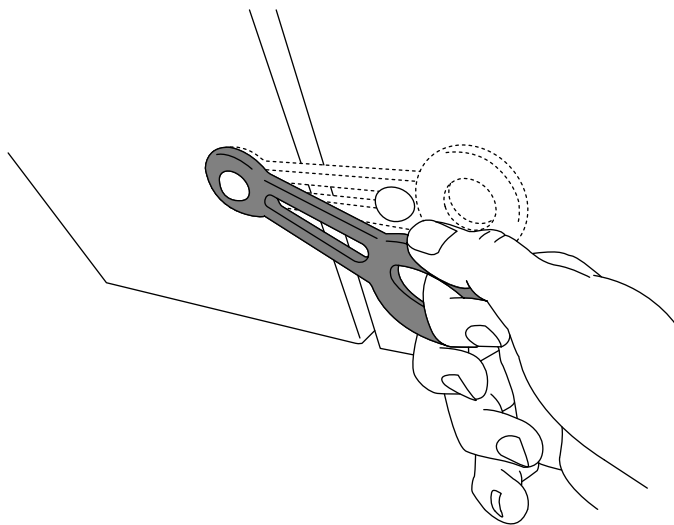

**Figure 13**

G019741

5. Extend the axle; refer to [Extending the Axle \(page 15\)](#).

## Checking the Tires and Wheels

**Service Interval:** Before each use or daily—Inspect the tires and wheels.

### ⚠ WARNING

Failure to maintain correct tire pressure may result in tire failure and loss of control, resulting in property damage and serious injury or death.

- Check the tire pressure frequently to ensure proper inflation. If the tires are not inflated to the correct pressure, they will wear prematurely.
- Inspect the tire condition before towing and after any operating accident.

The DOT tire information is located on the side of each tire. This information gives load and speed ratings. Replacement tires should have the same or better ratings. For more information go to <http://www.nhtsa.gov/Vehicle+Safety/Tires>.

**Note:** The various machines in this manual have different weights; refer to [Specifications \(page 11\)](#) to ensure that the tires on your machine meet or exceed the weight requirements of your machine.

1. Visually inspect the tires for damage and wear ([Figure 14](#) and [Figure 15](#)).

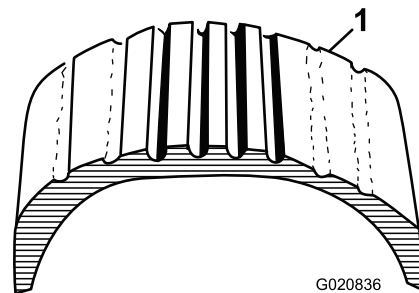

**Figure 14**

G020836

1. Example of tire wear caused by underinflation

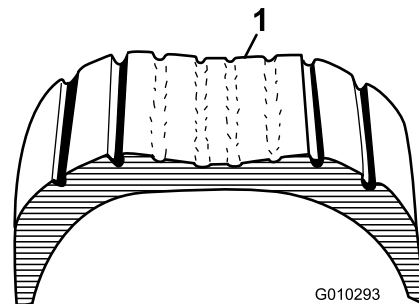

**Figure 15**

G010293

1. Example of tire wear caused by overinflation

2. Ensure that the tires are inflated to the correct air pressure. The following Tire Air Pressure table shows

the appropriate air pressure for the tires as installed at the factory.

**Important:** Always check the information on the actual tires for the correct air pressure requirement.

**Important:** The most common cause of tire trouble is under-inflation. Maintain full air pressure.

### Tire Air Pressure

Model	Tire pressure
68012	Max 414 kPa (60 psi)
68018, 68019	Max 241 kPa (35 psi)

3. Ensure that the wheel lug nuts are torqued to 108 to 122 N-m (80 to 90 ft-lb).

**Note:** Check the torque of the wheel lug nuts initially and after towing.

**Note:** Torque the lug nuts in the sequence shown in Figure 16.

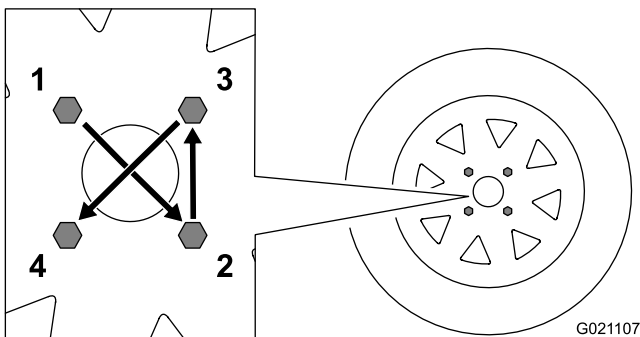

Figure 16

## Hitching a Machine with a Stamped Ball Coupler

1. Apply chassis grease to the socket of the coupler and the area of the clamp that contacts the ball. Oil the pivot points and sliding surfaces of the coupler with SAE 30 motor oil.
2. Open the coupler latch (Figure 17).

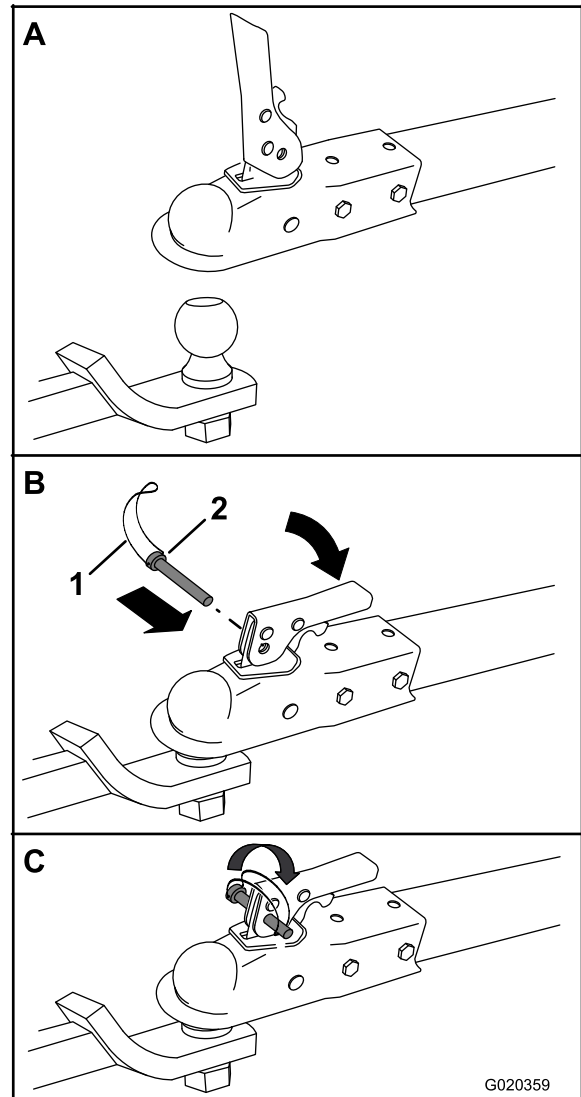

Figure 17

1. Bail
2. Safety pin

3. Position the coupler on top of the hitch ball (Figure 17).
4. Close the coupler latch (Figure 17).
5. Open the bail on the safety pin and insert the pin through the hole in the latch (Figure 17).
6. Rotate the free end of the bail over the end of the safety pin that is protruding through the latch (Figure 17).
7. If the machine is equipped with a trailer-light kit, connect the wire plug of the tow vehicle to the wire plug of the machine.

## Hitching a Machine with a Forged Ball Coupler

1. Apply removable thread-locking compound to the threads of the coupler bolt to prevent the coupler handle from coming loose (Figure 18).

**Important:** Apply thread-locking compound as needed in the future.

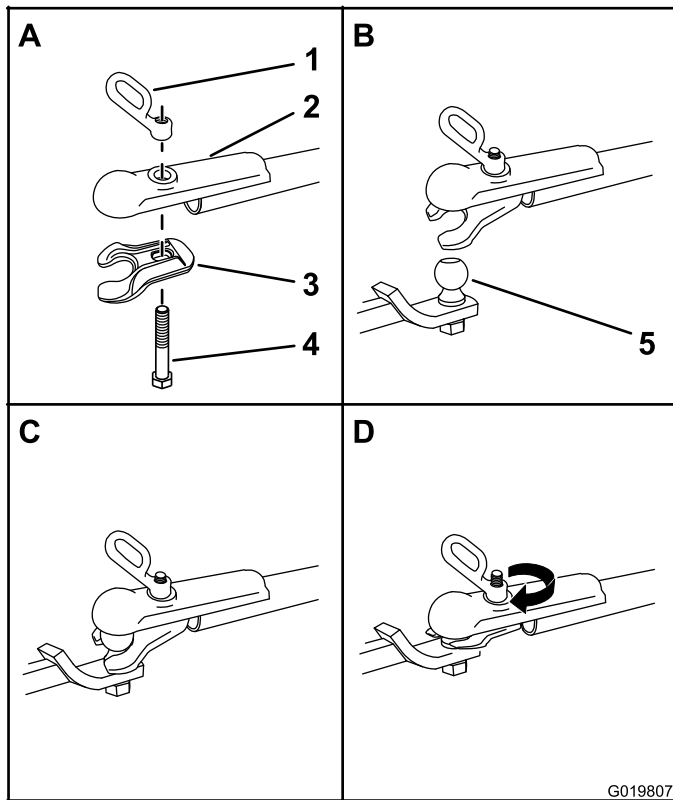

Figure 18

- |                   |               |
|-------------------|---------------|
| 1. Coupler handle | 4. Bolt       |
| 2. Coupler        | 5. Hitch ball |
| 3. Clamp          |               |

2. Apply chassis grease to the socket of the coupler and the area of the clamp that contacts the ball.
3. Push the coupler bolt up through the coupler clamp and the coupler top, and connect the coupler handle to the bolt (Figure 18).
4. Position the coupler so the socket is on top of the hitch ball and the clamp is under the ball.
5. Turn the coupler handle clockwise to thread it onto the bolt until it is secure (Figure 18).

**Note:** Use a wrench to keep the bolt from spinning.

6. If the machine is equipped with a trailer-light kit, connect the wire plug of the tow vehicle to the wire plug of the machine.

## Hitching a Machine with a Pintle Hitch Tow Pole

1. Remove the pin from the pintle hitch and open it (Figure 19).

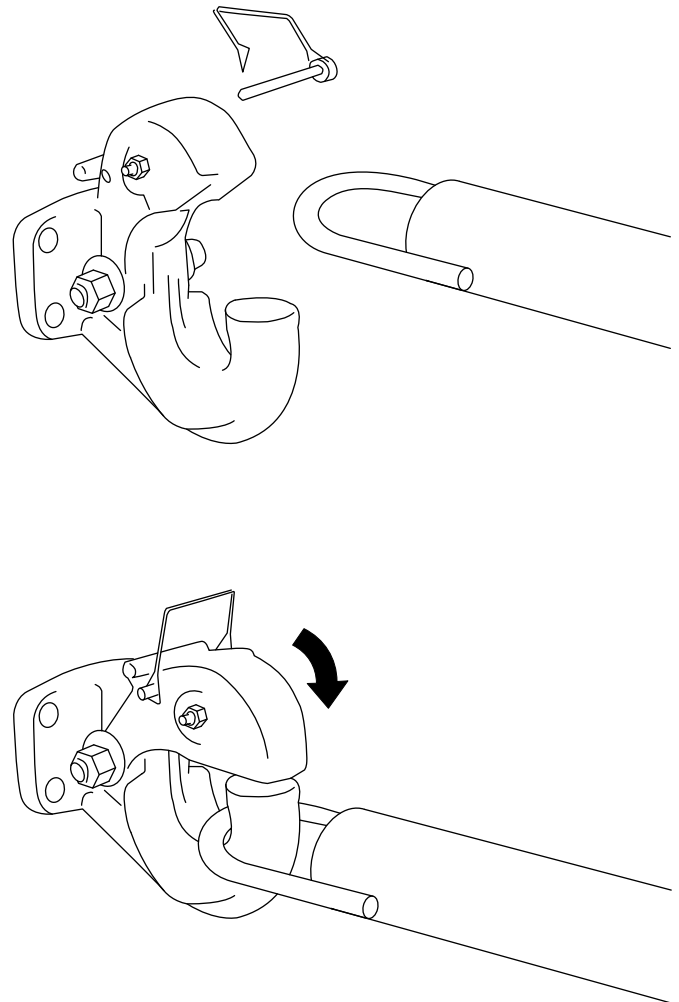

Figure 19

G019809

2. Position the ring on the tow pole onto the hook of the pintle hitch (Figure 19).
3. Close the top of the pintle hitch and secure it with the pin (Figure 19).
4. If the machine is equipped with a trailer-light kit, connect the wire plug of the tow vehicle to the wire plug of the machine.

## Connecting the Safety Chains to the Tow Vehicle

Connect the safety chain to the machine and the tow vehicle as follows:

1. Pull the safety chain through the slots in the keyholes located in the front post of the machine, so that there is just enough slack on each side for turning around corners when towing the machine (Figure 20).

**Note:** Stow the excess chain inside the bottom of the front post by pushing it into the keyholes and latching the appropriate links into the keyhole slots.

2. Cross both lengths of chain **under** the tow pole.

**Note:** Crossing the chains decreases the chances of the front of the machine dropping to the ground if the hitch does not hold the connection.

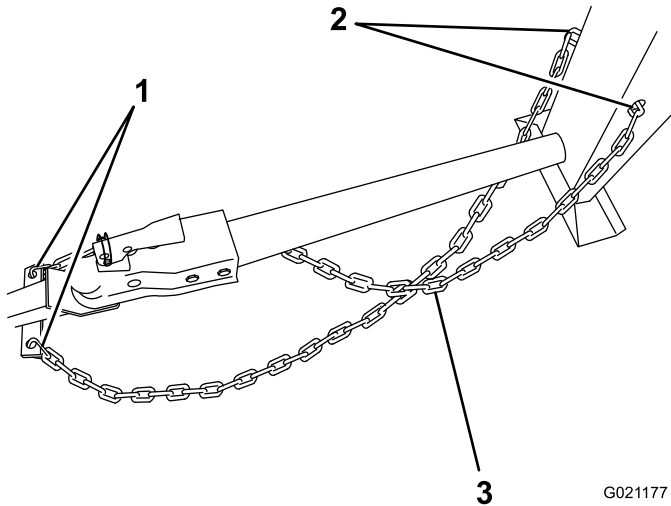
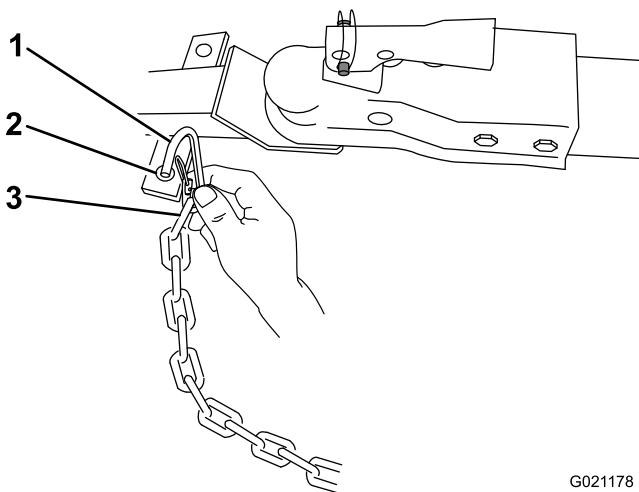

**Figure 20**

G021177

- |                           |                                 |
|---------------------------|---------------------------------|
| 1. Connecting links       | 3. Chain crossed under tow pole |
| 2. Keyholes in front post |                                 |

3. Connect each length of chain to the safety chain mounting point on the tow vehicle with the connecting links (Figure 21).



**Figure 21**

G021178

- |   |               |
|---|---------------|
| 1. Connecting link                            | 3. Chain link |
| 2. Safety chain mounting point on tow vehicle |               |

## Extending the Axle

### ⚠ WARNING

The machine is not stable when towing it with the axle in the narrow position.

Tow the machine with the axle in the wide position.

**Important:** Adjust the axle to the narrow position only to move the machine through a narrow access point, such as the gate of a fence or the doorway of a building.

## Preparing to Change the Axle Width

1. Move the machine to a level job-site surface.
2. Disconnect the machine from the tow vehicle.
3. Chock the tires.
4. Ensure that the drum is empty and in the mix position (upright).
5. Ensure that the drum latch is engaged and that the drum does not rotate toward the dump position.

## Adjusting the Axle Width

### ⚠ WARNING

Mechanical or hydraulic jacks may fail to support the machine and cause serious injury.

Use jack stands when supporting the machine.

1. Align a jack with an adequate lift height and weight capacity under the axle; refer to [Specifications](#) (page 11).
2. Lift the machine until the tires are off the ground.
3. Use a jack stand at each support point on the rear frame extension (Figure 22).

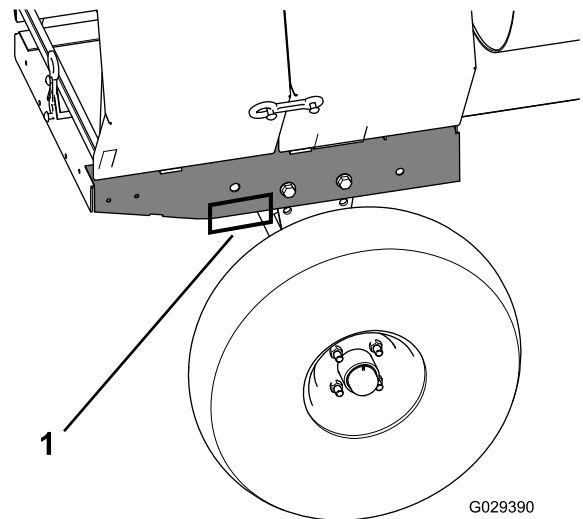

**Figure 22**

G029390

1. Support point (2)

- Remove the bolts and nuts that secure the inner axle to the outer axle (Figure 23).

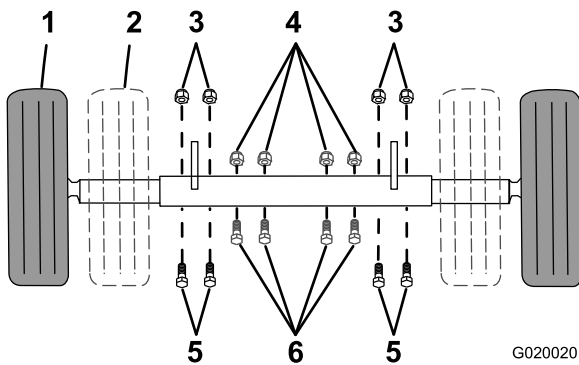

Figure 23

- |                           |                           |
|---------------------------|---------------------------|
| 1. Wide position (towing) | 4. Nut (narrow position)  |
| 2. Narrow position        | 5. Bolt (wide position)   |
| 3. Nut (wide position)    | 6. Bolt (narrow position) |

- Align the inner axle to the desired position as follows:
  - Slide each side of the axle inward to the narrow position (Figure 23).
  - Slide each side of the axle outward to the wide (tow) position (Figure 23).
- Align the holes of the inner axle with the holes of the outer axle.
- Insert the bolts through the axle holes (Figure 23).
- Thread the nuts onto the bolts, and torque the nuts to 87 N-m (64 ft-lb).

## Towing the Machine

### ⚠ WARNING

Towing the machine at high speed increases the risk of a hitch malfunction and tire failure. Higher speeds also increase the momentum of the machine and braking distance. If the machine becomes detached from the tow vehicle at high speed, it could cause damage to property, or injury or death to bystanders.

Do not exceed 88 km/h (55 mph) when towing the machine. For poor road conditions or inclement weather, reduce speed accordingly.

### ⚠ WARNING

Towing the machine with material in the drum increases the risk of a hitch malfunction and tire failure. In addition, material could bounce out of the drum and hit other vehicles and/or people. Material in the drum increases the weight, which affects momentum and braking distance.

Do not tow the machine with material in the drum.

- Review and understand [Safe Operating Practices](#) (page 3).
- Test the brakes of the tow vehicle before towing.
- Avoid sudden starts and stops while towing the machine.

## Preparing to Use the Machine

- Review all of the safety decals on the machine.
- Use a hard-hat, hearing protection, a shirt with long sleeves that are tight at the wrists, tight-fitting gloves without draw strings or loose cuffs, eye protection, and a dust mask or respirator. A mesh visor alone does not provide sufficient eye protection; supplement with protective glasses.
- Ensure that you are familiar with the safety regulations and shutdown procedures described in the *Operator's Manual*.
- Ensure that all guards are in place and in good condition.
- Ensure that the paddles are in place and in good condition.
- Check all the grease fittings to ensure that the machine is properly lubricated.
- When preparing to mix material:
  - Move the machine to a level job-site surface.
  - Remove the machine from the tow vehicle.
  - Chock the front and back of the tires to prevent the machine from moving.
  - Ensure that the drum is in the mix position (upright).
  - Ensure that the drum latch is engaged and that the drum does not rotate toward the dump position.



# Opening and Closing the Cowl

## Opening the Cowl

1. At the side of the machine where the front cowl and rear cowl meet, grasp the latch and pull it off from the latch anchor on the rear cowl (Figure 24).

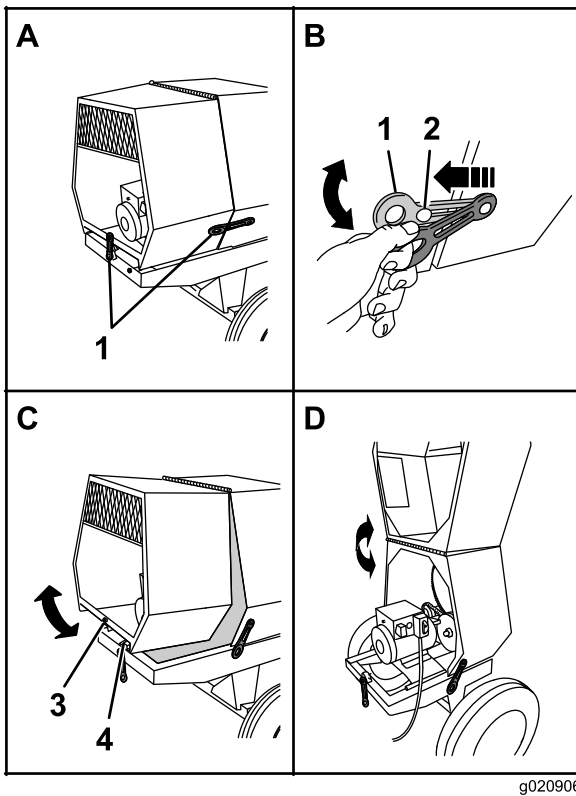

Figure 24

1. Latch
2. Latch anchor
3. Receiver
4. V-fitting

2. Repeat step 1 on the opposite side of the machine.
3. At the back of the machine where the rear cowl meets the frame of the machine, grasp the latch and pull it off from the latch anchor on the cowl (Figure 24).
4. Rotate the rear cowl up and forward until it is fully positioned on top of the front cowl (Figure 24).

## Closing the Cowl

1. Rotate the rear cowl rearward and down until the receiver at the bottom center of the cowl is aligned with the V-fitting and flush on the frame of the machine (Figure 24).
2. At the back of the machine, grasp the latch and pull it onto the latch anchor on the rear cowl.
3. At the side of the machine, grasp the latch and pull it onto the latch anchor on the rear cowl.
4. Repeat step 3 at the opposite side of the machine (Figure 24).

# Powering the Machine

## Setting the Operating Voltage

The machine can operate with a 115 V or 230 V supply voltage. The voltage block determines the operating voltage of the machine ( ). Use the following steps to change the operating voltage:

1. Park the machine on level ground.
2. Stop the motor and unplug the machine.
3. Remove the 2 screws securing the voltage block to the motor.
4. Remove the voltage block from the motor, rotate the voltage block 180 degrees and plug it back into the motor.
5. Secure the voltage plug to the motor with the 2 screws that you previously removed.

**Note:** Use the instructions on the voltage block to determine the voltage block setting.

## Connecting to a Power Source

### **⚠ DANGER**

Contact with water while operating the product could cause electric shock, causing injury or death.

- Do not handle the plug or the machine with wet hands or while standing in water.
- Use only an extension cord recommended for outdoor cold-weather use.

**Important:** Check the extension cord frequently during use for holes or cracks in the insulation. Do not use a damaged cord. Do not run the cord through standing water or wet grass.

**Important:** Use only extension cords with terminals and sockets for the live, neutral, and ground wires.

**Important:** Connect the machine to only a receptacle with live, neutral, and ground connections.

**Important:** The connecting wires or extension cord should be as short as possible and in 1 piece.

To reduce the risk of electric shock, this machine has a polarized plug (unique blade shapes and widths). Use only a polarized plug and socket that is compliant with NEMA specifications and an extension cord that is UL-listed (CSA certified in Canada) and recommended for outdoor use. A polarized plug will fit in a polarized cord only 1 way. If the plug does not fit fully into the cord, turn the cord. If it still does not fit, purchase an appropriate extension cord. If you have a polarized extension cord and the extension cord plug does not fit fully into the wall receptacle, turn the

plug. If it still does not fit, contact a qualified electrician to install the proper outlet. Do not change the machine plug or extension-cord plug in any way.

**Note:** The machine uses a twist-locking plug.

### Extension Cords

Length	Wire Gauge
15.2 m (50 ft)	10 AWG
22.8 m (75 ft)	10 AWG
30.4 m (100 ft)	8 AWG

**Note:** Do not use an extension cord over 30.4 m (100 ft) long.

## Powering the Machine with a Portable Generator

When using a portable generator as an electrical source, ensure the following power output specifications:

Model	Voltage	Amperes	Kilowatt hour	Frequency phase
68012	115 V / 230 V	19 A / 9.5 A	2.2 to 2.3 Kw	60 Hz / single
68018	115 V / 230 V	19 A / 9.5 A	2.2 to 2.3 Kw	60 Hz / single
68019	115 V / 230 V	24 A / 12 A	2.2 to 2.3 Kw	60 Hz / single

## Resetting the Motor

The electrical motor for the machine is equipped with a device for thermal-overload protection. In the event that the motor shuts down automatically, reset the thermal-overload protector as follows:

1. Move the ON/OFF switch to the OFF position; refer to [Figure 12](#).
2. Disconnect the electrical plug for the machine from the power source ([Figure 25](#)).

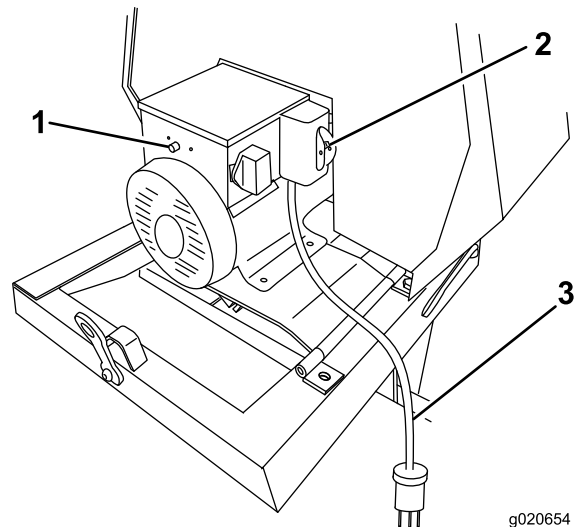

**Figure 25**

1. Thermal-overload protector reset button
2. ON/OFF switch
3. Electrical plug

3. Allow the electric motor of the machine to cool until it is warm to the touch or cooler.

**Important:** Ensure that the paddles spin freely. Check for stone, masonry, or concrete material between the paddles and the drum.

- On the side of the junction box for the motor, press the reset button for the thermal-overload protector (Figure 25).
- Connect the electrical plug for the machine to the power source.
- Rotate the ON/OFF switch to the ON position and ensure that the motor starts normally.
- Rotate the ON/OFF switch to the OFF position.

## Starting and Stopping the Motor

### Starting the Motor

- Plug the power cord into a proper electrical outlet.
- Switch the ON/OFF switch to the ON position.
- Move the clutch lever to the ON position; refer to [Controlling the Paddles \(page 19\)](#)

### Stopping the Motor

#### ⚠ WARNING

In an emergency situation, stop the motor immediately.

- Move the clutch lever to the OFF position; refer to [Controlling the Paddles \(page 19\)](#).
- Switch the ON/OFF switch to the OFF position; refer to [Motor ON/OFF Switch \(page 11\)](#).
- Unplug the power cord.

## Controlling the Paddles

#### ⚠ DANGER

This machine is capable of amputating hands.

- Stay in the operator's position while the machine is running.
- Keep all bystanders a safe distance from the machine.
- Stop the machine immediately if any people or animals enter the work area.
- Never place any part of your body into a position that causes an unsafe operating condition.

**Important:** Ensure that the paddles do not turn when the clutch lever is in the OFF position.

Use the clutch lever to control the power transmission to the paddles of the machine.

## Using the Clutch Lever

Move the clutch lever clockwise to engage the clutch, and counterclockwise to disengage the clutch (Figure 26).

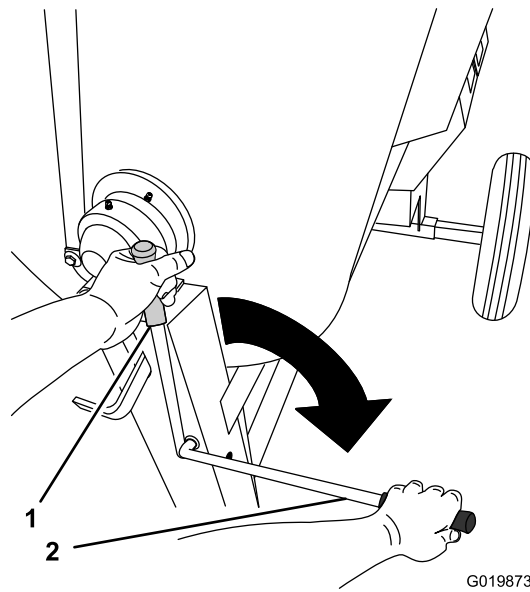

Figure 26

1. OFF position

2. ON position

G019873

## Mixing the Material

#### ⚠ DANGER

Eye and skin contact with concrete materials and breathing the dust involved is hazardous to your health.

- Ensure that there is adequate air ventilation.
- Wear a dust mask to prevent inhalation of dust while using the machine; refer to [Safe Operating Practices \(page 3\)](#).
- Avoid direct contact of cement and concrete materials with skin and eyes.

#### ⚠ DANGER

Contact with the mixing paddles could cause damage or injury.

Never put your hands inside the drum at any time.

**Important:** Do not add more material than the batch capacity of the machine; refer to [Specifications \(page 11\)](#).

**Note:** Follow the manufacturer's instructions that are printed on the packaging of the product you are using.

## Mixing a Batch of Material in the Machine

1. Ensure that there is no old, loose material in the drum that can contaminate the batch of material; refer to [Cleaning the Drum](#) (page 21) and [Dumping the Drum](#) (page 20), then return the drum to the upright position.

**Note:** Ensure that the drum is in the mix position (upright) and the drum latch is engaged.

2. Move the clutch lever to the OFF position; refer to [Controlling the Paddles](#) (page 19).
3. Start the motor; refer to [Starting the Motor](#) (page 19).
4. Move the clutch lever to the ON position; refer to [Controlling the Paddles](#) (page 19).
5. Add the ingredients for the batch as follows:
  - A. Pour water into the drum through the grating of the drum guard.
  - B. Add the plaster, cement, or other binding material.

**Note:** You can open bags of cement, plaster, and binding materials by lowering the bag onto the bag splitter ([Figure 27](#)).

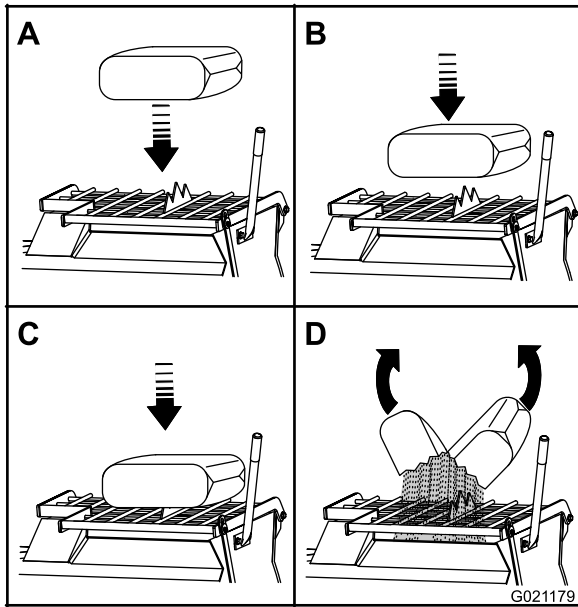

**Figure 27**

- C. If you are using sand and/or other reinforcing materials, add them into the drum.
6. Allow the paddles to mix the material until the ingredients have a uniform appearance.

**Note:** If needed, add water or plaster, cement, or other binding material until the consistency of the batch is correct.

7. Release the drum latch and dump the drum; refer to [Dumping the Drum](#) (page 20).

## Using the Drum

### **⚠ DANGER**

Contact with the mixing paddles could cause damage or injury.

Never put your hands inside the drum at any time.

## Dumping the Drum

**Note:** When dumping a batch of material, leave the motor running and the clutch in the ON position so the rotating paddles help discharge the material.

1. Align a wheelbarrow or similar container of adequate capacity in the path of the drum opening.
2. Grasp the dump handle with your left hand ([Figure 28](#)).

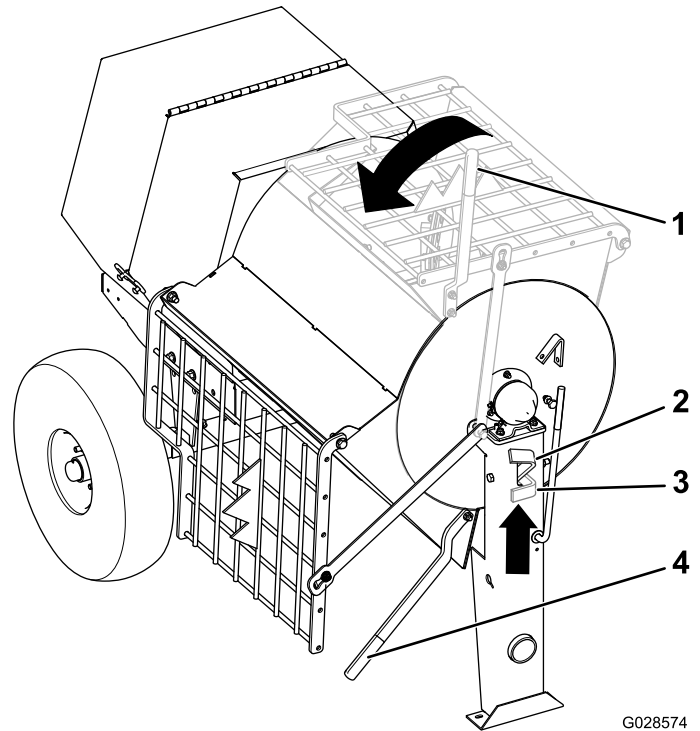

**Figure 28**

- |                                  |                                 |
|----------------------------------|---------------------------------|
| 1. Dump handle (mix position)    | 3. Drum latch (locked position) |
| 2. Drum latch (release position) | 4. Dump handle (dump position)  |

**Note:** When dumping a batch of material, align a wheelbarrow or a similar container of adequate capacity beneath the chute.

3. Lift the handle of the drum latch ([Figure 28](#)).
4. With both hands on the dump handle, rotate it counterclockwise to discharge the contents of the drum ([Figure 28](#)).

**Note:** Allow the machine to completely discharge the contents of the drum.

5. Rotate the dump handle **clockwise** until the drum latch locks the drum in the upright position ([Figure 28](#)).
6. After discharging a batch of material, clean the drum; refer to [Cleaning the Drum \(page 21\)](#).

**Note:** This step will clean the paddles and drum between batches and prevent dried material from forming, and contaminating the next batch of material.

## Cleaning the Drum

**Important:** Do not strike on the drum with a shovel, hammer, or any other device to loosen any accumulated dried materials.

1. Stop the rotation of the paddles by moving the clutch lever to the OFF position; refer to [Controlling the Paddles \(page 19\)](#).
2. Move the motor ON/OFF switch to the OFF position; refer to [Motor ON/OFF Switch \(page 11\)](#).
3. Ensure that the drum is in the mix position (upright); refer to [Dumping the Drum \(page 20\)](#), step 5.
4. Spray the machine with water to remove any accumulated material.
5. Start the motor; refer to [Starting the Motor \(page 19\)](#).
6. Start the rotation of the paddles by moving the clutch lever to the ON position; refer to [Controlling the Paddles \(page 19\)](#).
7. Dump the drum; refer to [Dumping the Drum \(page 20\)](#).

# Maintenance

**Important:** Before performing any maintenance procedures, first stop the motor, wait 5 minutes to allow all moving parts to come to a complete stop and cool, and unplug the power cord.

## Recommended Maintenance Schedule(s)

Maintenance Service Interval	Maintenance Procedure
After the first 10 hours	<ul style="list-style-type: none"><li>• Check the tension of the drive chain, and adjust it as needed.</li></ul>
After the first 25 hours	<ul style="list-style-type: none"><li>• Inspect the belts and adjust as necessary.</li></ul>
Before each use or daily	<ul style="list-style-type: none"><li>• Inspect the tires and wheels.</li></ul>
After each use	<ul style="list-style-type: none"><li>• Torque the lug nuts to 108 to 122 N-m (80 to 90 ft-lb) after towing.</li><li>• Clean the drum between mixing batches of material.</li><li>• Lubricate the trunnions.</li><li>• Clean the machine.</li></ul>
Every 40 hours	<ul style="list-style-type: none"><li>• Lubricate the drive chain with a non-sticky chain lubricant.</li><li>• Inspect the belts and adjust as necessary.</li><li>• Check the clutch operation.</li></ul>
Every 50 hours	<ul style="list-style-type: none"><li>• Check the tension of the drive chain, and adjust it as needed.</li></ul>
Every 6,000 hours	<ul style="list-style-type: none"><li>• Lubricate the motor bearings.</li></ul>
Monthly	<ul style="list-style-type: none"><li>• Lubricate the pillow-block bearings.</li></ul>
Every 2 years	<ul style="list-style-type: none"><li>• Replace the belts.</li></ul>

## Premaintenance Procedures

### Preparing the Machine for Maintenance

1. Park the machine on a level surface.
2. Remove the machine from the tow vehicle.
3. Chock the tires.
4. Open the rear cowl; refer to [Opening the Cowl \(page 17\)](#).
5. Turn off and unplug the motor; refer to [Motor ON/OFF Switch \(page 11\)](#).
6. Ensure that the motor is cool.

### Removing and Installing the Divider Plate

You need to remove the divider plate to provide access before performing some maintenance procedures.

### Removing the Divider Plate

1. Unlatch and open the cowl; refer to [Opening the Cowl \(page 17\)](#).
2. Use a wrench to remove the 4 bolts that secure the divider plate to the front cowl.

**Note:** Keep the bolts for installing the divider plate.

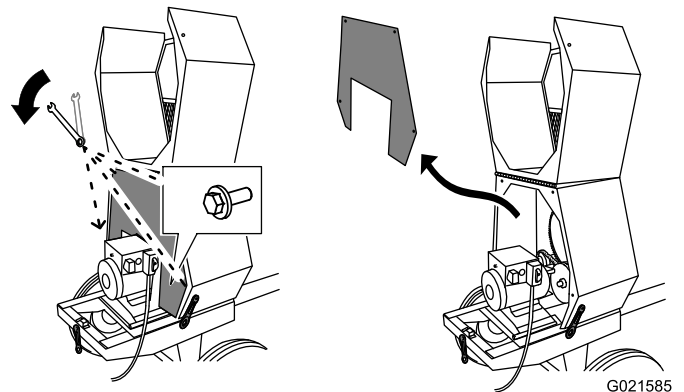

Figure 29

3. To remove the divider plate, lift it upward and rotate it counterclockwise so that it clears various components.

## Installing the Divider Plate

1. Guide the divider plate into position against the front cowl.

**Note:** Start with the divider plate rotated slightly counterclockwise, and then rotate it clockwise while lowering it into position.

Ensure that the divider plate is not backward.

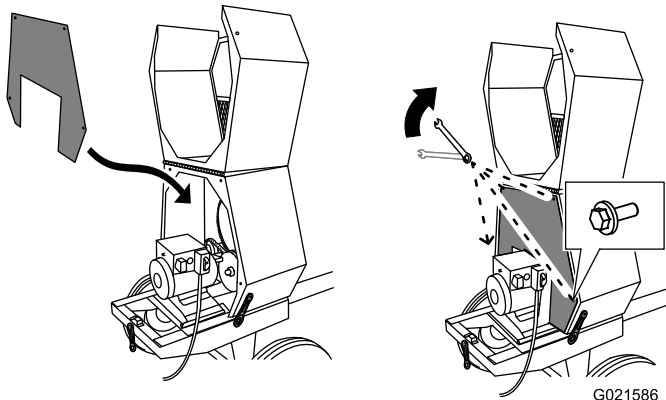

Figure 30

2. Align the bolt holes in the divider plate and the front cowl.
3. Install each of the 4 bolts, and hand-tighten them to prevent cross-threading.
4. Tighten the bolts with a wrench until they are secure.

## Lubrication

### Lubricating the Bearings and Seals

**Service Interval:** After each use—Lubricate the trunnions.

Monthly—Lubricate the pillow-block bearings.

**Note:** The pillow-block bearings are inside the cowl—remove the divider plate to access them; refer to [Removing the Divider Plate](#) (page 22).

**Grease type:** #2 general-purpose lithium-based grease.

1. Clean around each grease fitting with a rag and lift the plastic cap off the grease fitting ([Figure 31](#)).

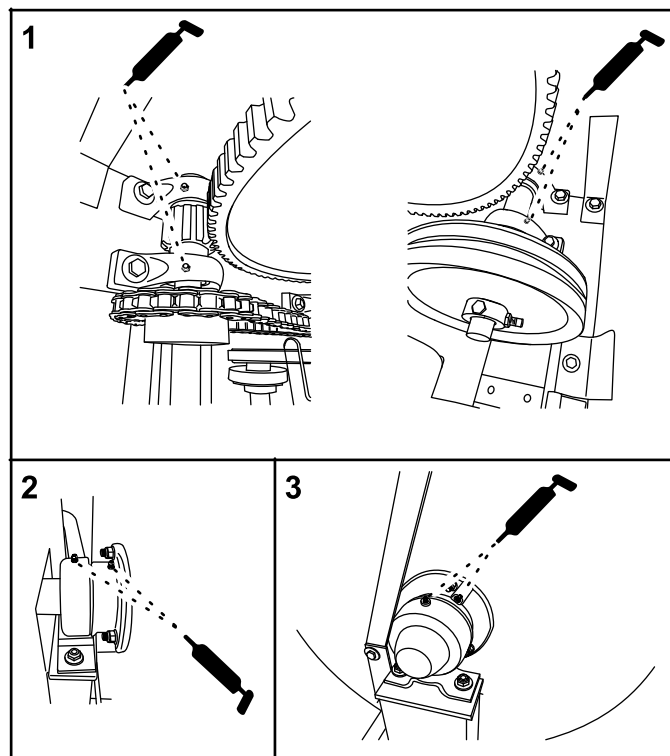
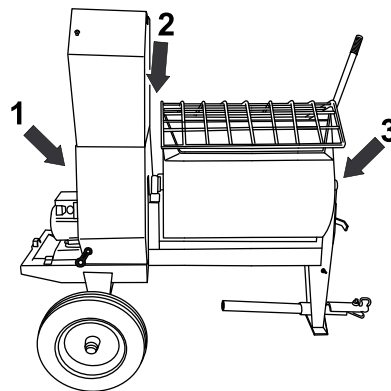

g021101

Figure 31

1. Pillow-block bearings
2. Rear trunnion
3. Front trunnion

2. Pump grease into each fitting as follows:
  - For the pillow-block bearings, pump 1 shot of grease into each fitting (Figure 31).
  - For the trunnions, pump several shots of grease into each fitting until it starts to ooze out of the bearing housing (Figure 31).

**Important:** Pump grease in slowly and carefully to prevent damage to the bearing seals.

3. Wipe up any excess grease.

## Lubricating the Motor Bearings

**Service Interval:** Every 6,000 hours

**Grease type:** electric-motor bearing grease

1. Clean around each grease fitting with a rag.
2. Pump 1 or 2 shots of grease into each fitting (Figure 32).

**Important:** Do not over-lubricate the motor.

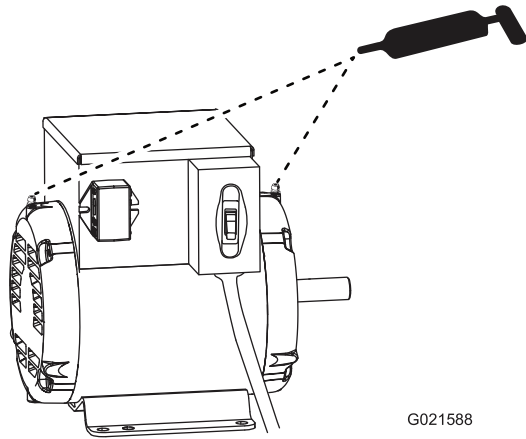

**Figure 32**

G021588

3. Wipe up any excess grease.

## Lubricating the Drive Chain

**Service Interval:** Every 40 hours—Lubricate the drive chain with a non-sticky chain lubricant.

Apply a chain lubricant that is non-sticky to help prevent dirt and abrasive particles from sticking to the chain.

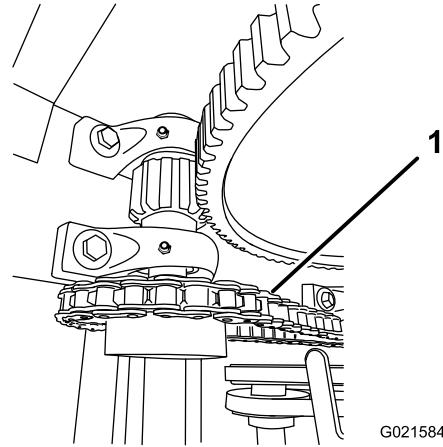

G021584

**Figure 33**

1. Drive chain



# Belt Maintenance

## Servicing the Belts

### Inspecting the Belts

**Service Interval:** After the first 25 hours—Inspect the belts and adjust as necessary.

Every 40 hours—Inspect the belts and adjust as necessary.

1. Remove the divider plate; refer to [Removing the Divider Plate](#) (page 22).
2. Move the clutch lever to the OFF position; refer to [Controlling the Paddles](#) (page 19).
3. Examine the belts for wear or damage. If the belts are worn or damaged, replace them; refer to [Replacing the Belts](#) (page 26).
4. Examine the pulleys for wear, damage, and misalignment; refer to [Aligning the Pulleys](#) (page 28).
5. Install the divider plate; refer to [Installing the Divider Plate](#) (page 23).

### Adjusting the Belt Tension

**Clutch air gap:** 2.5 to 6.5 mm (3/32 to 1/4 inch)

1. Move the clutch lever to the ON position; refer to [Controlling the Paddles](#) (page 19).
2. Measure the air gap between the motor deck and the roller on the clutch ([Figure 34](#)).

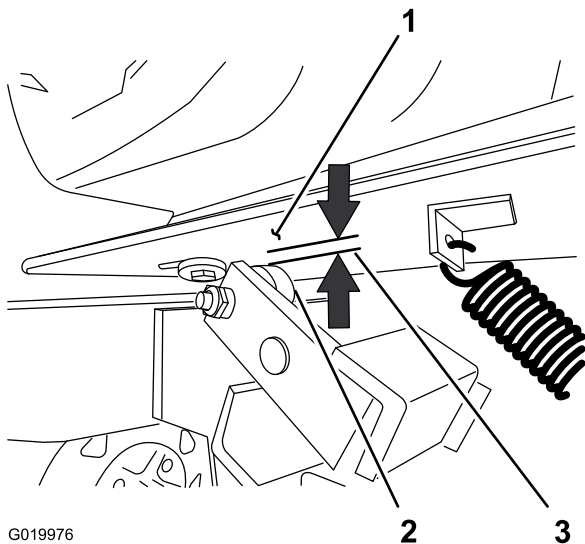

**Figure 34**

1. Motor deck
2. Clutch roller
3. Clutch air gap: 2.5 to 6.5 mm (3/32 to 1/4 inch)

- A. Move the clutch lever to the OFF position; refer to [Controlling the Paddles](#) (page 19).
- B. Loosen the nuts and bolts that secure the motor to the motor deck ([Figure 35](#)).

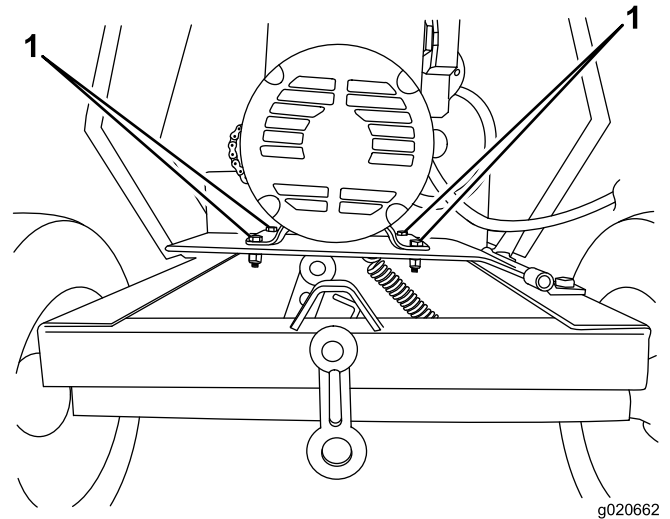
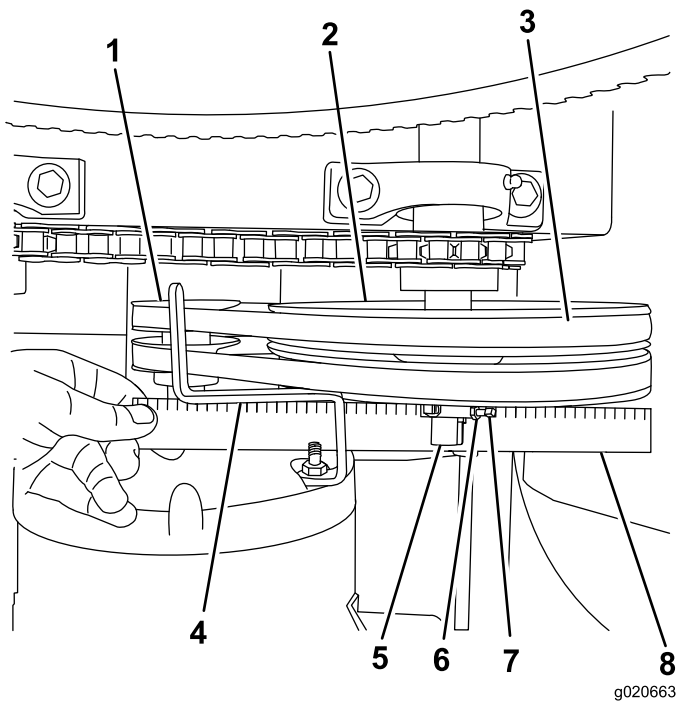

**Figure 35**

1. Nut and bolt

- C. Move the motor position as follows:
  - **Increase the air gap**—move the motor **away** from the idler pulley ([Figure 35](#)).
  - **Decrease the air gap**—move the motor **toward** the idler pulley ([Figure 35](#)).
- D. Align a straightedge across the motor pulley and the idler pulley ([Figure 36](#)).

3. If the measured air gap is not within the specified range, adjust the gap as follows:



**Figure 36**

- |                 |                 |
|-----------------|-----------------|
| 1. Motor pulley | 5. Idler shaft  |
| 2. Idler pulley | 6. Jam nut      |
| 3. Belt         | 7. Setscrew     |
| 4. Belt guide   | 8. Straightedge |

- E. If needed, pivot the motor on the motor deck until the motor pulley and the idler pulley are aligned to the straightedge (Figure 36).
- F. Tighten the nuts and bolts that secure the motor to the motor deck to a torque of 18 N-m (13 ft-lb).
- G. Check the air gap between the motor deck and the roller on the clutch. If the air gap is not within the specified range, repeat step 3 until the air gap measurement is within the specified range.
- H. Install the divider plate; refer to [Installing the Divider Plate \(page 23\)](#).

**Important:** Ensure that the paddles do not rotate when the clutch lever is in the OFF position.

## Replacing the Belts

**Service Interval:** Every 2 years—Replace the belts.

### Removing the Belts

1. Move the clutch lever to the OFF position; refer to [Controlling the Paddles \(page 19\)](#).
2. Remove the divider plate; refer to [Removing the Divider Plate \(page 22\)](#).
3. Remove the nut that secures the belt guide to the motor, and remove the belt guide (Figure 37).

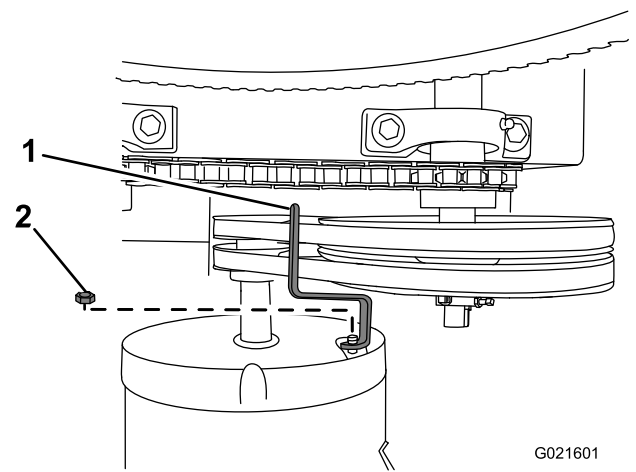

**Figure 37**

1. Nut
2. Belt guide

4. Slip the forward belt forward and off the idler pulley (Figure 38).

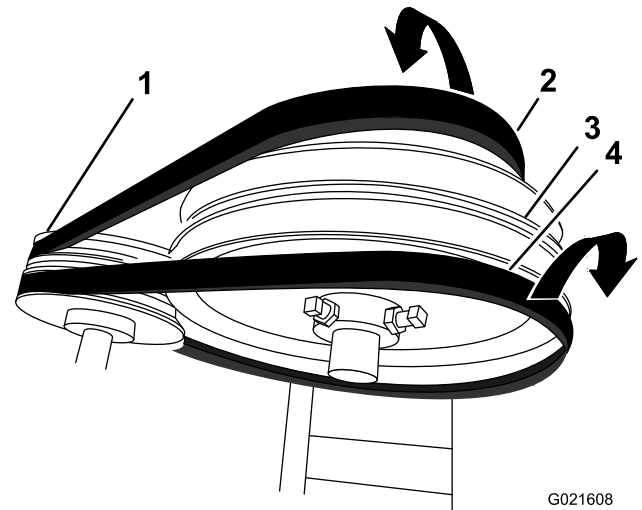

**Figure 38**

- |                 |                 |
|-----------------|-----------------|
| 1. Motor pulley | 3. Idler pulley |
| 2. Forward belt | 4. Rear belt    |

5. Slip the rear belt rearward and off the idler pulley (Figure 38).
6. Slip the belts off the motor pulley.
7. Remove the belts from the machine.

### Installing the Belts

1. Ensure that the clutch lever is in the OFF position; refer to [Controlling the Paddles \(page 19\)](#).
  2. Align the rear belt to the rear groove in the motor pulley.
- Note:** Do not align the rear belt to the idler pulley.
3. Align the forward belt to the forward groove of the idler pulley.

4. Slip the rear belt over the idler pulley and align the belt to the rear pulley groove.
5. Slip the forward belt over the motor pulley and align the belt to the forward pulley groove.
6. Check the belt tension; refer to step 1, step 2, and step 3 in [Adjusting the Belt Tension](#) (page 25).
7. Loosely secure the belt guide to the motor ([Figure 37](#)) with the bolt that was removed in step 3 of [Removing the Belts](#) (page 26).
8. Adjust the belt guide; refer to [Adjusting the Belt Guide](#) (page 27).
9. Install the divider plate; refer to [Installing the Divider Plate](#) (page 23).

## Adjusting the Belt Guide

**Note:** To access the belt guide, remove the divider plate; refer to [Removing the Divider Plate](#) (page 22).

**Guide air gap:** 2.5 to 4.0 mm (3/32 to 5/32 inch)

1. Ensure that the clutch lever is in the ON position; refer to [Controlling the Paddles](#) (page 19).
2. Ensure that the belt tension is correct; refer to [Adjusting the Belt Tension](#) (page 25).
3. Check that the air gap between the belt guide and the belts is 2.5 to 4.0 mm (3/32 to 5/32 inch); refer to [Figure 39](#).

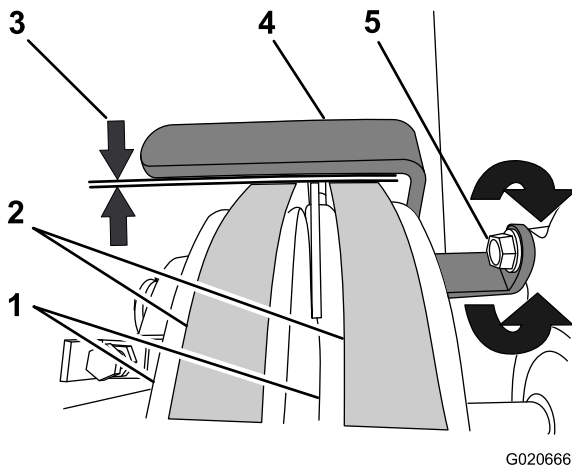

**Figure 39**

- |   |               |
|---|---------------|
| 1. Motor pulleys                                    | 4. Belt guide |
| 2. Belts  | 5. Nut        |
| 3. Guide air gap: 2.5 to 4.0 mm (3/32 to 5/32 inch) |               |

- B. Rotate the belt guide up or down until there is an air gap of 2.5 to 4.0 mm (3/32 to 5/32 inch) between the guide and each belt ([Figure 39](#)).

**Important:** The belt guide should not contact the belts with the clutch lever in the ON position.

**Note:** If the air gap between the belt guide and both belts cannot be attained, then 1 of the belts is too long.

- C. Tighten the nut that secures the belt guide to the motor ([Figure 39](#)).
  - D. Check the clutch operation; refer to [Checking the Clutch Operation](#) (page 27).
5. Install the divider plate; refer to [Installing the Divider Plate](#) (page 23).

## Checking the Clutch Operation

**Service Interval:** Every 40 hours—Check the clutch operation.

**Important:** The paddles must not rotate in an empty drum when the clutch lever is in the OFF position.

1. Move the clutch lever to the OFF position; refer to [Controlling the Paddles](#) (page 19).
2. Start the motor; refer to [Starting the Motor](#) (page 19).
3. If the paddles rotate with the clutch lever to the OFF position do the following:
  - A. Stop the motor; refer to [Stopping the Motor](#) (page 19).
  - B. Check the air gap between the belt guide and the belts.
 

**Note:** If the air gap is larger than 4.0 mm (5/32 inch), decrease the gap between the belt guide and the belts; refer to [Adjusting the Belt Guide](#) (page 27).
4. Repeat steps 1, 2, and 3 until the following conditions are met:
  - The clutch lever is in the OFF position.
  - While the motor is running, the paddles do not rotate in an empty drum.

4. If the air gap is not within the specified range, do the following:
  - A. Loosen the nut that secures the belt guide to the motor ([Figure 39](#)).

**Important:** Ensure that the belt guide is toward the motor pulley.

## Aligning the Pulleys

1. Remove the divider plate; refer to [Removing the Divider Plate \(page 22\)](#).
2. Place a straightedge across the face of the motor pulley and the idler pulley ([Figure 40](#)).

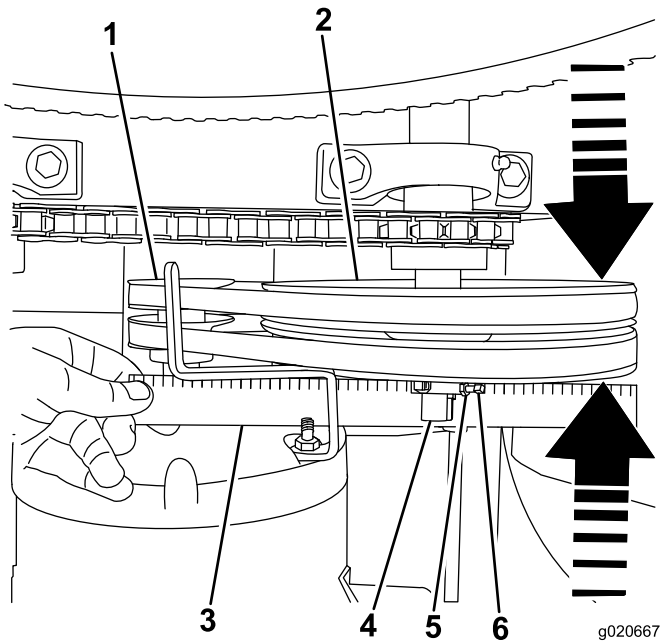

**Figure 40**

- |                 |                |
|-----------------|----------------|
| 1. Motor pulley | 4. Idler shaft |
| 2. Idler pulley | 5. Locknut     |
| 3. Straightedge | 6. Setscrew    |

**Note:** Both pulleys must be aligned flush with the straightedge.

3. If the pulleys are not aligned do the following:
  - A. Move the clutch lever to the OFF position.
  - B. Loosen the locknuts and setscrews that secure the idler pulley to the idler shaft ([Figure 40](#)).
  - C. Using a soft-face mallet, tap the idler pulley forward or backward along the idler shaft until the motor pulley and the idler pulley are aligned to the straightedge ([Figure 40](#)).
  - D. Tighten the setscrews and locknuts that secure the idler pulley to the idler shaft ([Figure 40](#)).
4. Install the divider plate; refer to [Installing the Divider Plate \(page 23\)](#).

## Drive Chain Maintenance

### Checking and Adjusting the Drive Chain

**Service Interval:** After the first 10 hours  
Every 50 hours

The drive chain should have 5 to 10 mm (7/32 to 13/32 inch) of flex when applying 6.8 kg (15 lb) of pressure at mid-span.

### Checking the Drive-Chain Tension

1. Remove the divider plate; refer to [Removing the Divider Plate \(page 22\)](#).
2. Place a straightedge along the chain from 1 sprocket to the other ([Figure 41](#)).

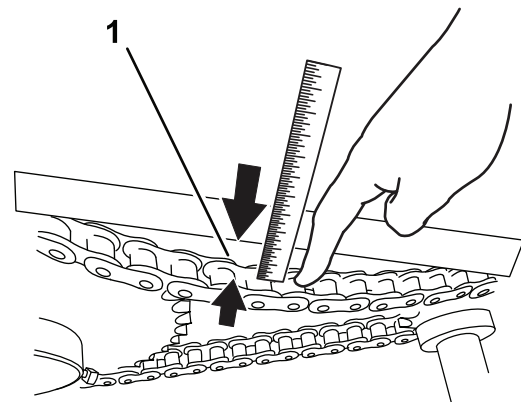

**Figure 41**

1. Flex of 5 to 10 mm (7/32 to 13/32 inch)

3. With your finger, push on the chain with 6.8 kg (15 lb) of pressure, midway between the sprockets ([Figure 41](#)).
4. Measure the distance from the chain to the straightedge; the distance should be 5 to 10 mm (7/32 to 13/32 inch). If the chain tension needs adjustment, refer to [Adjusting the Drive-Chain Tension \(page 28\)](#).
5. Install the divider plate; refer to [Installing the Divider Plate \(page 23\)](#).

### Adjusting the Drive-Chain Tension

**Note:** Adjusting the tension of the drive chain affects the tension of the belts; adjust the belt tension after adjusting the drive-chain tension.

1. Remove the divider plate; refer to [Removing the Divider Plate \(page 22\)](#).
2. Loosen the nuts and bolts that secure the pillow-block bearings for the idler pulley ([Figure 42](#)).

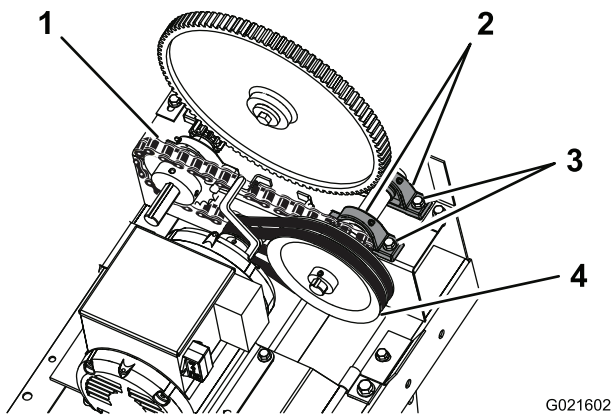
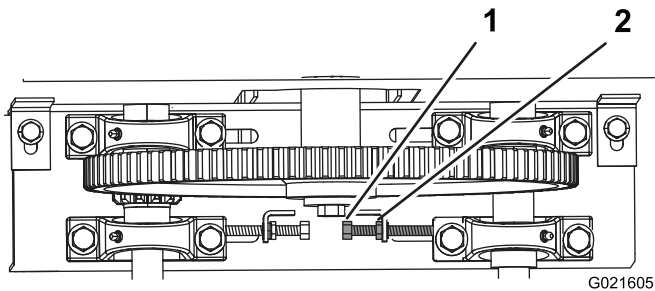

**Figure 42**

- |                          |                 |
|--------------------------|-----------------|
| 1. Drive chain           | 3. Bolts (4)    |
| 2. Pillow-block bearings | 4. Idler pulley |

- Slide the pillow-block bearings, along with the idler pulley and small sprocket, to the **right** to increase the chain tension, or to the **left** to decrease the chain tension.

**Note:** To slide the pillow-block bearings to the left, you must loosen the jam nut and tensioner bolt (Figure 43). To slide the pillow-block bearings to the right, you must loosen the motor mounting nuts and bolts (Figure 35).



**Figure 43**

- |                   |            |
|-------------------|------------|
| 1. Tensioner bolt | 2. Jam nut |
|-------------------|------------|

- When the chain has 5 to 10 mm (7/32 to 13/32 inch) of flex, tighten the tensioner bolt, the jam nut, and the nuts and bolts that secure the pillow-block bearings.
- Adjust the belt tension; refer to [Adjusting the Belt Guide \(page 27\)](#).
- Install the divider plate; refer to [Installing the Divider Plate \(page 23\)](#).

# Paddle Maintenance

**Note:** Over time, you may need to adjust the mixer paddles to account for wear.

## Adjusting the Paddles

### Aligning the Circumferential Drum Wipers

- Rotate a paddle from the left row of paddles around the drum and locate at the interior of the drum the smallest distance between the drum and the wiper of the paddle (Figure 44).
- Mark the inside of the inside of the drum at the location that you determined in step 1.

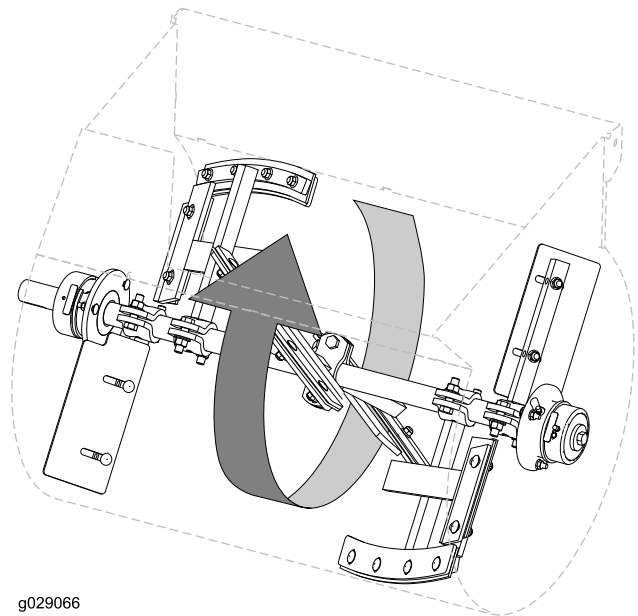

**Figure 44**

- Align the wiper of a paddle to the mark.
- Loosen the carriage bolts and flanged locknuts that secure the paddle blade and wiper to the paddle (Figure 45).

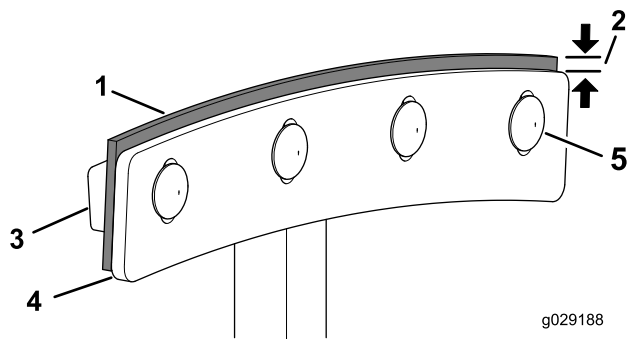

**Figure 45**

- |  |                                      |
|--|--------------------------------------|
| 1. Wiper   | 4. Paddle blade                      |
| 2. Distance between paddle-blade edge and wiper edge—3 to 6 mm (1/8 to 1/4 inch) | 5. Carriage bolt and flanged locknut |
| 3. Wiper bar   |                                      |

- Adjust the position of the wiper so that the wiper lightly contacts the drum across the length of the wiper (Figure 46).

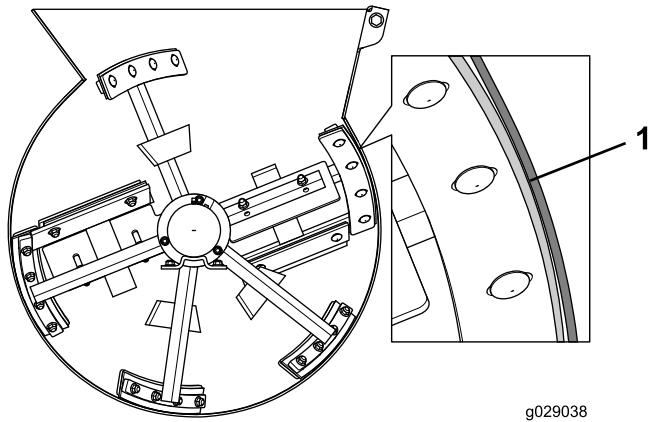
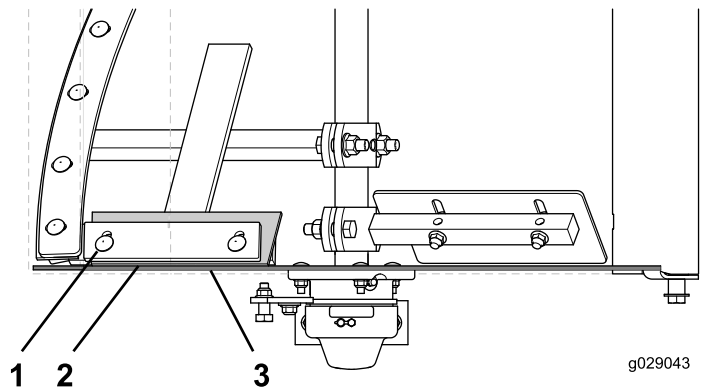

**Figure 46**

- Wiper lightly contacting the drum at the smallest distance between the drum and the wiper of the paddle
- Adjust the position of the paddle blade so that the outer edge is 3 to 6 mm (1/8 to 1/4 inch) from the outer edge of the wiper.
- Torque the carriage bolts and nuts to 19 to 25 N-m (14 to 18 ft-lb).
- Repeat steps 4 through 7 for the other paddle for that paddle row.
- Repeat the procedure for the other paddle rows.

## Aligning the End Paddle Wipers

- Rotate the wiper and fixed paddle around the endplate of the drum and locate smallest distance between the drum and the wiper of the paddle.
- Mark the inside of the endplate at the location that you determined in step 1.



**Figure 47**

- |                                      |                  |
|--------------------------------------|------------------|
| 1. Carriage bolt and flanged locknut | 3. Drum endplate |
| 2. Closest point of contact          |                  |

- Align the wiper of a paddle to the mark.
- Loosen the carriage bolts and flanged locknuts that secure the paddle blade and wiper to the fixed paddle. (Figure 47)
- Adjust the position of the wiper so that the wiper lightly contacts the end plate across the length of the wiper.
- Adjust the position of the paddle blade so that the outer edge of the bar is 3 to 6 mm (1/8 to 1/4 inch) from the outer edge of the wiper.
- Torque the carriage bolts and nuts to 19 to 25 N-m (14 to 18 ft-lb).
- Repeat the procedure for the wiper at the end plate on the other end of the drum.

## Aligning the Adjustable End Paddles

1. Align the adjustable end paddle to the mark that you made in step 2 of [Aligning the End Paddle Wipers](#) (page 30).
2. Loosen the carriage bolts and flanged locknuts that secure the adjustable end paddle to the fixed paddle. (Figure 48)

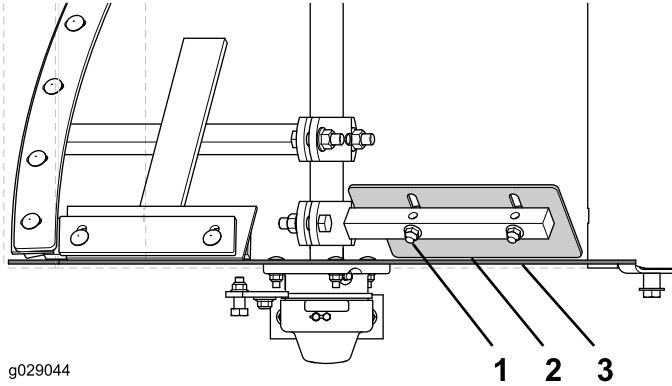

Figure 48

1. Carriage bolt and flanged locknut
2. Closest point of contact
3. Drum endplate

3. Adjust the position of the adjustable end paddle so that it is as close to the end plate as possible, across the length of the paddle, without touching end plate when the paddles are rotated.
4. Torque the carriage bolts and nuts to 37 to 45 N-m (27 to 33 ft-lb).
5. Repeat the procedure for the adjustable end paddle at the end plate on the other end of the drum.

## Cleaning

### Cleaning the Machine

Regular cleaning and washing will increase the life span of the machine. Clean the machine after each use, before the dirt hardens.

Ensure that the motor is unplugged.

Use care when using a high-pressure sprayer because it can damage warning decals, instruction signs, and the motor.

**Important:** Use pressure sprayers to clean only the drum of the machine. Clean off the rest of the machine by hand to keep the motor from getting wet.

**Important:** Lubricate the trunnions after cleaning; refer to [Lubricating the Bearings and Seals](#) (page 23).

# Storage

## Storing the Machine

For storage over 30 days, prepare the machine as follows:

1. Move the ON/OFF switch to the OFF position, and unplug the power cord.
2. Remove dirt and grime from the external parts of the entire machine, especially the motor.

**Important:** You can wash the machine with mild detergent and water.

3. Grease the machine; refer to [Lubricating the Bearings and Seals \(page 23\)](#) and [Lubricating the Drive Chain \(page 24\)](#).
4. Check and tighten all bolts, nuts, and screws. Repair or replace any part that is damaged.
5. Paint all scratched or bare metal surfaces with paint from your Authorized Toro Dealer.
6. Store the machine in a clean, dry garage or storage area.
7. Cover the machine to protect it and keep it clean.



# Troubleshooting

Problem	Possible Cause	Corrective Action
The electric motor does not start.	<ol style="list-style-type: none"> <li>1. The connector for the machine is not plugged into a power source.</li> <li>2. The thermal-overload protection for the motors is activated.</li> <li>3. The current protector for the electrical source is open.</li> <li>4. The machine is plugged into an electrical source less than 115 volts or greater than 230 volts.</li> <li>5. The paddles are jammed inside the drum.</li> </ol>	<ol style="list-style-type: none"> <li>1. Plug the connector into a socket or an extension cord from an electrical source.</li> <li>2. Reset the thermal-overload protector.</li> <li>3. Reset the circuit protector.</li> <li>4. Connect the machine to an electrical source with the proper voltage.</li> <li>5. Disconnect the machine from the electrical source, move the clutch to the off position, and clear the debris from the inside of the drum.</li> </ol>
The machine is humming excessively.	<ol style="list-style-type: none"> <li>1. The cord is plugged into an incorrect outlet.</li> </ol>	<ol style="list-style-type: none"> <li>1. Check the input line connections.</li> </ol>
The motor is overheating.	<ol style="list-style-type: none"> <li>1. The motor is overloaded.</li> <li>2. There is not adequate ventilation.</li> <li>3. The motor is running over voltage or under voltage.</li> </ol>	<ol style="list-style-type: none"> <li>1. Compare the actual amps (measured) with the rating on the nameplate. Locate and remove the source of excessive friction in the motor or load. Reduce the load.</li> <li>2. Check the external cooling fins for excessive dirt buildup and clean the motor.</li> <li>3. Check the input voltage to the motor.</li> </ol>
The belt slips or comes off the pulleys.	<ol style="list-style-type: none"> <li>1. The belt tension is insufficient.</li> <li>2. The belt is worn.</li> <li>3. The pulley(s) are worn.</li> <li>4. The pulley(s) are misaligned.</li> </ol>	<ol style="list-style-type: none"> <li>1. Adjust the belt tension.</li> <li>2. Replace the belt.</li> <li>3. Contact your Authorized Service Dealer.</li> <li>4. Align the pulley(s).</li> </ol>
The paddles rotate when the clutch lever is in the OFF position.	<ol style="list-style-type: none"> <li>1. The clutch lever is not adjusted correctly.</li> <li>2. The belt guide is not adjusted correctly.</li> </ol>	<ol style="list-style-type: none"> <li>1. Adjust the belt tension.</li> <li>2. Adjust the belt guide.</li> </ol>
The paddles do not rotate when the clutch lever is in the ON position.	<ol style="list-style-type: none"> <li>1. The clutch lever is not adjusted correctly.</li> <li>2. The paddles are stuck in the drum</li> </ol>	<ol style="list-style-type: none"> <li>1. Adjust the belt tension.</li> <li>2. Clean the paddles and drum.</li> </ol>
The paddles rotate slowly when the clutch lever is in the ON position.	<ol style="list-style-type: none"> <li>1. The clutch lever is not adjusted correctly.</li> </ol>	<ol style="list-style-type: none"> <li>1. Adjust the belt tension.</li> </ol>
The mixer makes a chirping noise when mixing material.	<ol style="list-style-type: none"> <li>1. The drive gear is misaligned with the bull gear.</li> </ol>	<ol style="list-style-type: none"> <li>1. Contact your Authorized Service Dealer.</li> </ol>

# Schematics

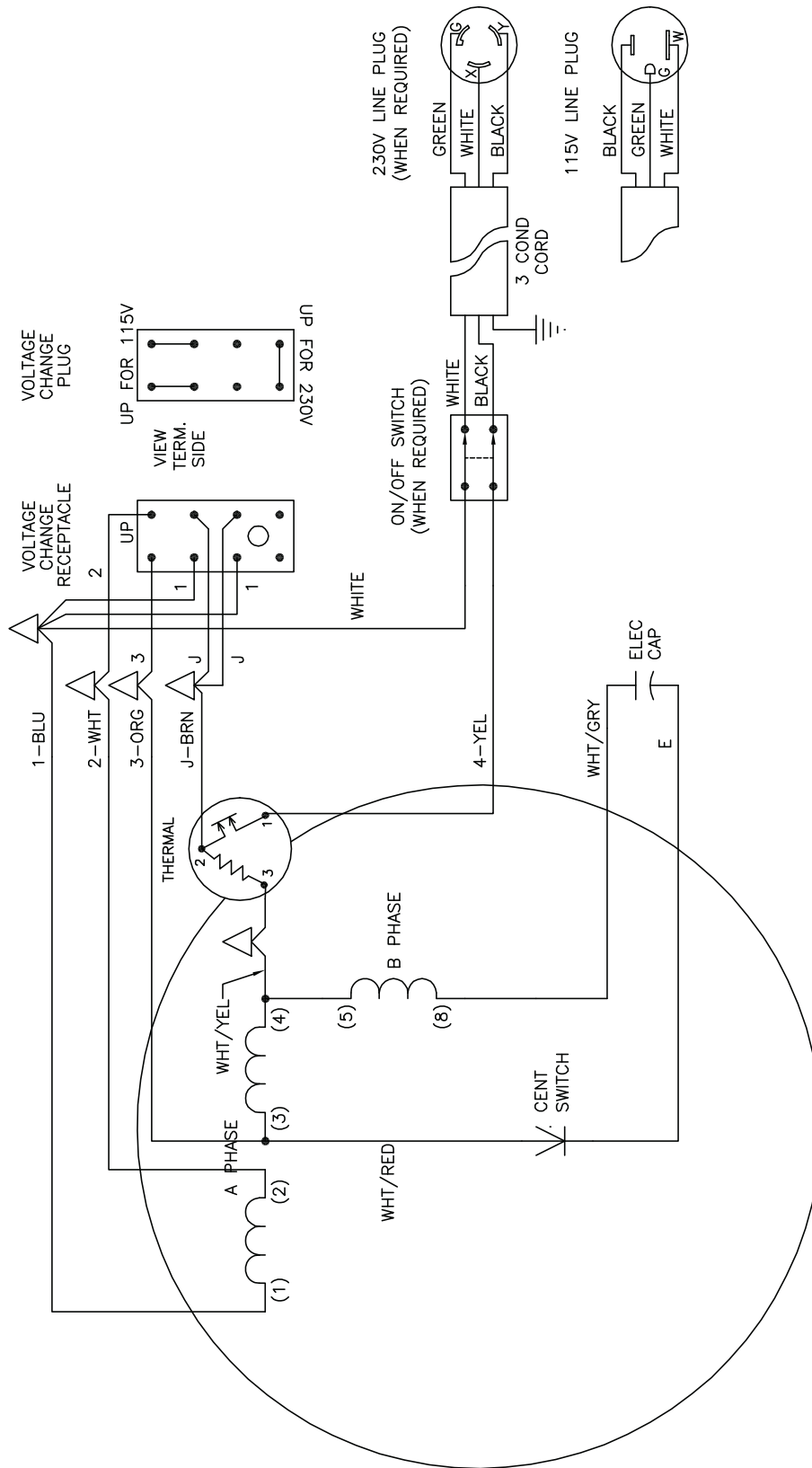

**NOTES:**

1. CONNECTIONS ARE SHOWN FOR CCW ROTATION FACING END OPPOSITE SHAFT EXTENSION (STD). FOR CW ROTATION, INTERCHANGE (5) AND (8) INTERNALLY.
2. MULTIPLE CAPACITORS ARE CONNECTED IN PARALLEL UNLESS OTHERWISE SPECIFIED.
3. LEAD COLORS ARE OPTIONAL. LEADS MUST ALWAYS BE NUMBERED AS SHOWN.

**Electric Motor Schematic (Rev. A)**

G021587

**Notes:**



## The Toro Warranty

A limited warranty (see warranty periods below)

Concrete,  
Masonry, and  
Compaction  
Equipment

### Conditions and Products Covered

The Toro Company and its affiliate, Toro Warranty Company, pursuant to an agreement between them, jointly warrant your Toro Concrete, Masonry, and Compaction Equipment Products listed below to be free from defects in materials or workmanship.

This warranty covers the cost of parts and labor, but you must pay transportation costs.

The following time periods apply from the date of purchase:

Products	Warranty Period
Concrete Mixers	1 year
• Spindle Bearings	Lifetime* (original owner only)
Mortar Mixers	1 year
• Drum Bearings and Seals	Lifetime* (original owner only)
Forward Plate Compactors	2 years
Reversible Plates	1 year
Rammer Compactors	2 years
Mud Buggy	1 year
Vibrating Trench Roller	2 years
Concrete Saws	1 year
Masonry Saws	1 year
Power Trowels	1 year
Screeds	1 year
Concrete Vibrators	1 year

Where a warrantable condition exists, we will repair the Product at no cost to you including diagnosis, labor, and parts.

\*Lifetime Warranty - If the bearing(s) or seal(s) on your mixer fail, it will be replaced under warranty, at no cost for parts or labor.

### Instructions for Obtaining Warranty Service

If you think that your Toro Product contains a defect in materials or workmanship, follow this procedure\*\*:

1. Contact any Authorized Servicing Outlet to arrange service at their dealership. To locate one convenient to you, access our website at [www.Toro.com](http://www.Toro.com). Select "Where to Buy" and select "Contractor" under product type. You may also call our toll free number below.
2. Bring the product and your proof of purchase (sales receipt) to them.
3. If for any reason you are dissatisfied with the Service Outlet's analysis or with the assistance provided, contact us at:

SWS Customer Care Department  
Toro Warranty Company  
8111 Lyndale Avenue South  
Bloomington, MN 55420-1196  
Toll Free: 800-888-9926

\*\*Toro Authorized Rental Customers who have purchased products directly from Toro and have signed the Toro Rental Customer Agreement have the ability to perform their own warranty work. Please visit Toro's Rental Portal for electronic warranty claim filing procedures or call the toll free number above.

### Owner Responsibilities

You must maintain your Toro Product by following the maintenance procedures described in the *Operator's Manual*. Such routine maintenance, whether performed by a dealer or by you, is at your expense. Parts scheduled for replacement as required maintenance ("Maintenance Parts"), are warranted for the period of time up to the scheduled replacement time

### Countries Other than the United States or Canada

Customers who have purchased Toro products outside the United States or Canada should contact their Toro Distributor (Dealer) to obtain guarantee policies for your country, province, or state. If for any reason you are dissatisfied with your Distributor's service or have difficulty obtaining guarantee information, contact the Toro importer. If all other remedies fail, you may contact us at Toro Warranty Company.

**Australian Consumer Law:** Australian customers will find details relating to the Australian Consumer Law either inside the box or at your local Toro Dealer.

for that part. Failure to perform required maintenance and adjustments can be grounds for disallowing a warranty claim.

### Items and Conditions Not Covered

Not all product failures or malfunctions that occur during the warranty period are defects in materials or workmanship. This express warranty does not cover the following:

- Product failures which result from the use of non-Toro replacement parts, or from installation and use of add-on, modified, or unapproved accessories
- Product failures which result from failure to perform required maintenance and/or adjustments
- Product failures which result from operating the Product in an abusive, negligent or reckless manner
- Parts subject to consumption through use unless found to be defective. Examples of parts which are consumed, or used up, during normal product operation include, but are not limited to, belts, wipers, spark plugs, tires, filters, gaskets, wear plates, seals, O-rings, drive chains, clutches.
- Failures caused by outside influence. Items considered to be outside influence include, but are not limited to, weather, storage practices, contamination, use of unapproved coolants, lubricants, additives, or chemicals, etc.
- Normal "wear and tear" items. Normal "wear and tear" includes, but is not limited to, worn painted surfaces, scratched decals, etc.
- Repairs necessary due to failure to follow recommended fuel procedure (consult *Operator's Manual* for more details)
  - Removing contaminants from the fuel system is not covered
  - Use of old fuel (more than one month old) or fuel which contains more than 10% ethanol or more than 15% MTBE
  - Failure to drain the fuel system prior to any period of non-use over one month
- Any component covered by a separate manufacturer's warranty
- Pickup and delivery charges

### General Conditions

Repair by an Authorized Servicing Outlet or Self-Service as an Authorized Rental Customer is your sole remedy under the warranty.

**Neither The Toro Company nor Toro Warranty Company is liable for indirect, incidental or consequential damages in connection with the use of the Toro Products covered by this warranty, including any cost or expense of providing substitute equipment or service during reasonable periods of malfunction or non-use pending completion of repairs under this warranty. All implied warranties of merchantability and fitness for use are limited to the duration of this express warranty. Some states do not allow exclusions of incidental or consequential damages, or limitations on how long an implied warranty lasts, so the above exclusions and limitations may not apply to you.**

This warranty gives you specific legal rights, and you may also have other rights which vary from state to state.

Except for the engine warranty coverage and the Emissions warranty referenced below, if applicable, there is no other express warranty. The Emissions Control System on your Product may be covered by a separate warranty meeting requirements established by the U.S. Environmental Protection Agency (EPA) or the California Air Resources Board (CARB). Refer to the California Emission Control Warranty Statement supplied with your Product or contained in the engine manufacturer's documentation for details.