



Count on it.

Parts Catalog

TimeCutter® SS 3225

Riding Mower

Model No. 74710—Serial No. 315000875 and Up



Ordering Replacement Parts

To order replacement parts, please supply the part number, the quantity, and the description of each part desired.

Understanding Reference Numbers

Each identified part in an illustration has a reference number. The reference number for a part also appears in the parts list, along with other information about the part.

This catalog uses two special reference number formats, one to indicate parts in a service assembly and another to indicate the quantity of a given part in an illustration.

Service Assembly Reference Numbers

Parts in service assemblies have reference numbers in the form a:b. The a represents the reference number of the entire service assembly and the b represents a sequential number unique to each part within the service assembly.

For example, a wheel assembly might be identified by reference number 6, the tire by 6:1, the valve by 6:2, and the wheel by 6:3. When you order the assembly identified by reference number 6, you receive all parts identified by reference numbers 6:1, 6:2, and 6:3. However, you may also order any part individually. Reference numbers of this type appear in illustration and in parts lists.

Reference Numbers Indicating Quantity

In an illustration, if a reference number indicates more than one part, the reference number has the form nX y. The n represents the quantity of the part, the X is the multiplication symbol, and the y represents the reference number.

For example, in an illustration, the reference number 2X 37 means that two of the parts identified by reference number 37 are indicated.

List of Abbreviations

AR: as required

ASM: assembly

BBC: blade brake control

BHTF: button head thread forming

CARR: carriage

CCW: counter clockwise

CW: clockwise

DEG: degrees

DPA: Dual Point Adjustment

ECM: electronic control module

EXT: external

FH: flat head

GA: gauge

HD: heavy-duty

HF: hex flange

HH: hex head

HHF: hex head flange

HHFTF: hex head flange thread forming

HJ: hex jam

HLH: hex lag head

HOC: height-of-cut

HP: high pressure

HSBH: hex socket button head

HSFH: hex socket flat head

HSH: hex socket head

HWH: hex washer head

HWHTF: hex washer head thread forming

HYD: hydraulic

LH: left hand

LP: low pressure

LPG: Liquefied Petroleum Gas

NI: nylon insert

NPTF: national pipe thread fine

PFH: phillips flat head

PPH: phillips pan head

PPHTF: phillips pan head thread forming

PRH: phillips round head

PTH: phillips truss head

PTO: power-take-off

RH: right hand

ROPS: roll-over protection system

RRB: rear roller brush

SFH: slotted fillister head

SHH: slotted hex head

SHWH: slotted hex washer head

SPH: slotted pan head

SQH: square head

SRH: slotted round head

STD: standard

TAP: self tapping

TTH: torx truss head

Contents

Frame, Front Axle and Caster Wheel Assembly	4
Caster Wheel Assembly	6
Deck Lift Assembly	8
Motion Control Assembly	10
Brake Assembly	12
Seat Assembly	14
Belt and Idler Assembly	16
Hydro Transaxle Assembly	18
4 Ply Wheel and Tire Assembly No. 119-3422	20
2 Ply Wheel and Tire Assembly No. 131-3670	22
Left Hand Hydro Transaxle Assembly No. 119-3330	24
Right Hand Hydro Transaxle Assembly No. 119-3331	26
Clutch Assembly	28
Engine and Muffler Assembly	30
Air Intake and Filtration Engine Assembly No. 121-0412	32
Fuel System Assembly Engine Assembly No. 121-0412	34
Ignition and Electrical Assembly Engine Assembly No. 121-0412	36
Crankcase Assembly Engine Assembly No. 121-0412	38
Piston and Cylinder Head Assembly Engine Assembly No. 121-0412	40
Governor Control Engine Assembly No. 121-0412	42
Blower Housing Assembly Engine Assembly No. 121-0412	44
Gasket and Seal Kit Engine Assembly No. 121-0412	46
Fuel Delivery Assembly	48
Body Styling and Fuel Tank Assembly	50
Battery and Electrical Assembly	52
Fuse and Wire Harness Assembly	54
32 Inch Deck Assembly	56
32 Inch Deck, Belt and Blade Assembly	58
Attachments and Accessories	60

Frame, Front Axle and Caster Wheel Assembly

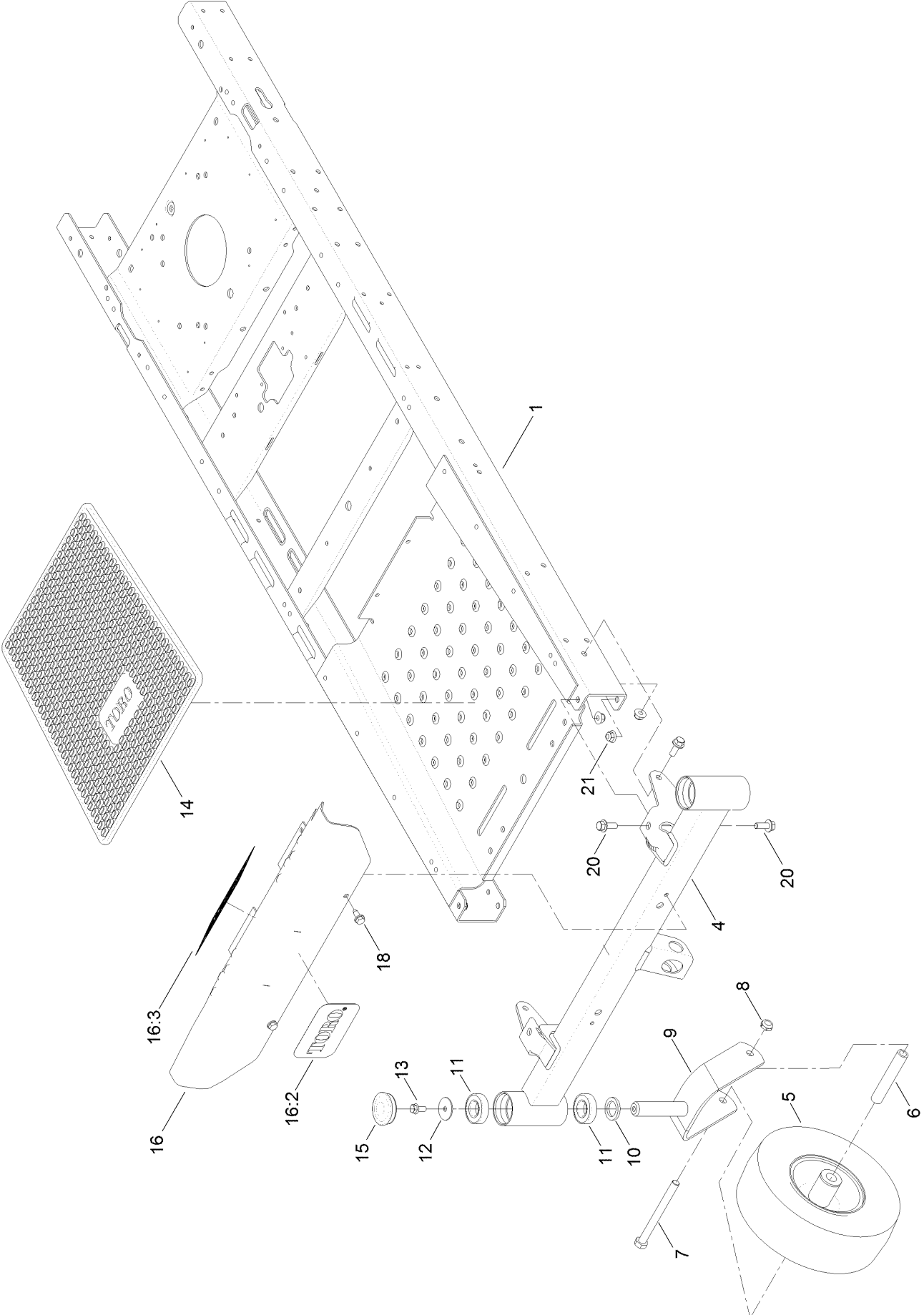

Frame, Front Axle and Caster Wheel Assembly (continued)

<i>Ref.</i>	<i>Part Number</i>	<i>Qty.</i>	<i>Description</i>	<i>Ref.</i>	<i>Part Number</i>	<i>Qty.</i>	<i>Description</i>
1	127-3444-01	1	Frame ASM	13	3234-47	2	Screw-HHF
4	125-1742-01	1	Axle-Front, Narrow	14	120-5455	1	Mat-Floor
5	130-0736	2	Caster Wheel ASM	15	116-4348	2	Cap-Grease
6	104-3667	2	Spanner-Wheel	16	125-0072	1	Footrest ASM
7	325-22	2	Screw-HH	16:2	105-8278	1	Decal
8	3296-45	2	Nut-Lock, NI	16:3	120-2239	1	Decal-Danger
9	120-7964-01	2	Caster Fork ASM	18	32144-70	2	Screw-HWHTF
10	117-7394	2	Washer-Thrust	20	3234-42	6	Screw-HHF
11	109-3678	4	Bearing-Ball	21	104-8301	6	Nut-Flange, NI
12	3256-68	2	Washer-Flat				

Caster Wheel Assembly

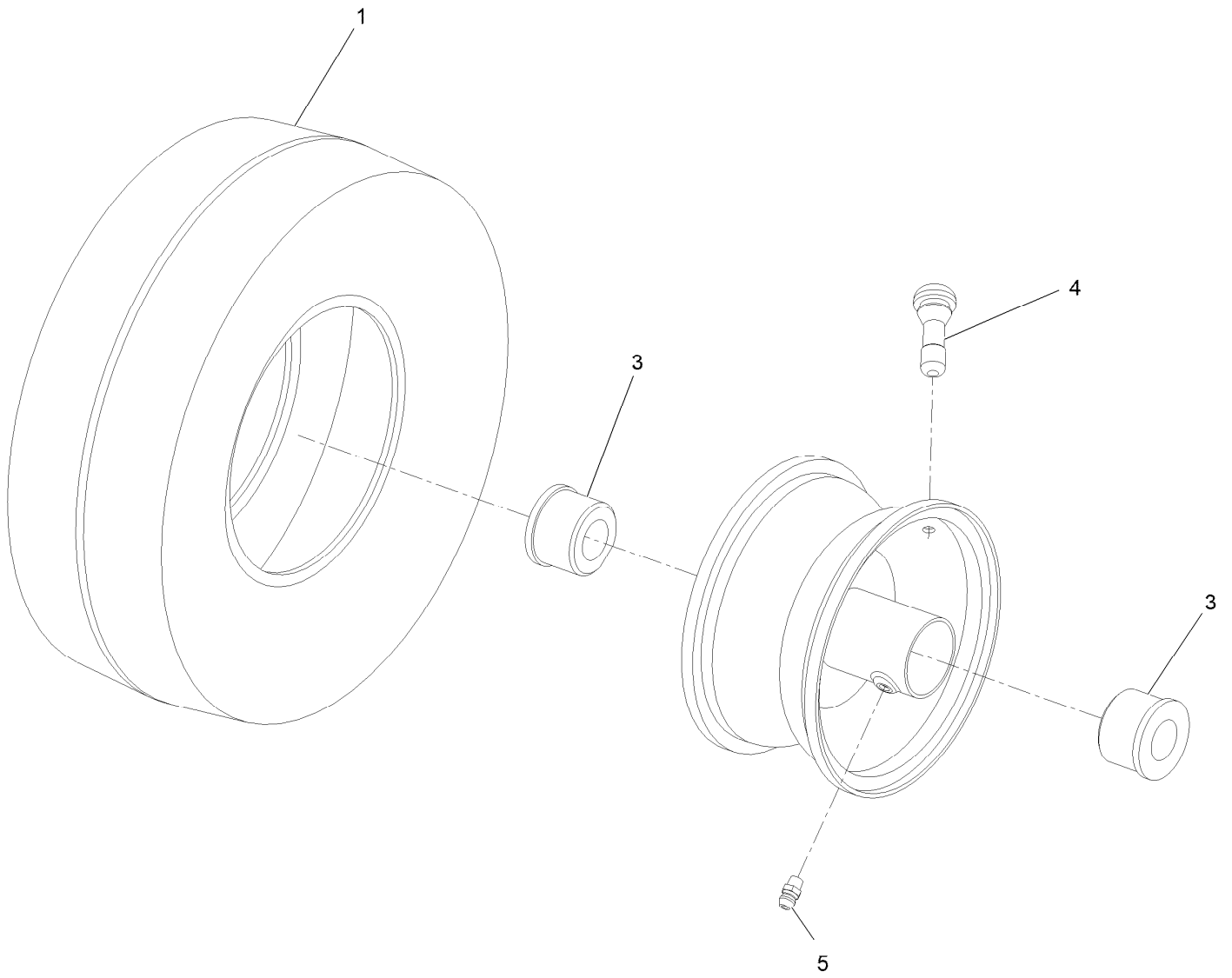

Caster Wheel Assembly (continued)

<i>Ref.</i>	<i>Part Number</i>	<i>Qty.</i>	<i>Description</i>	<i>Ref.</i>	<i>Part Number</i>	<i>Qty.</i>	<i>Description</i>
1	130-0735	1	Tire	5	302-5	1	Fitting-Grease
3	114-1640	2	Bushing-Flange	99	105-0844	1	Tube-Inner ●
4	232-27	1	Stem-Valve				

● Not illustrated

Deck Lift Assembly

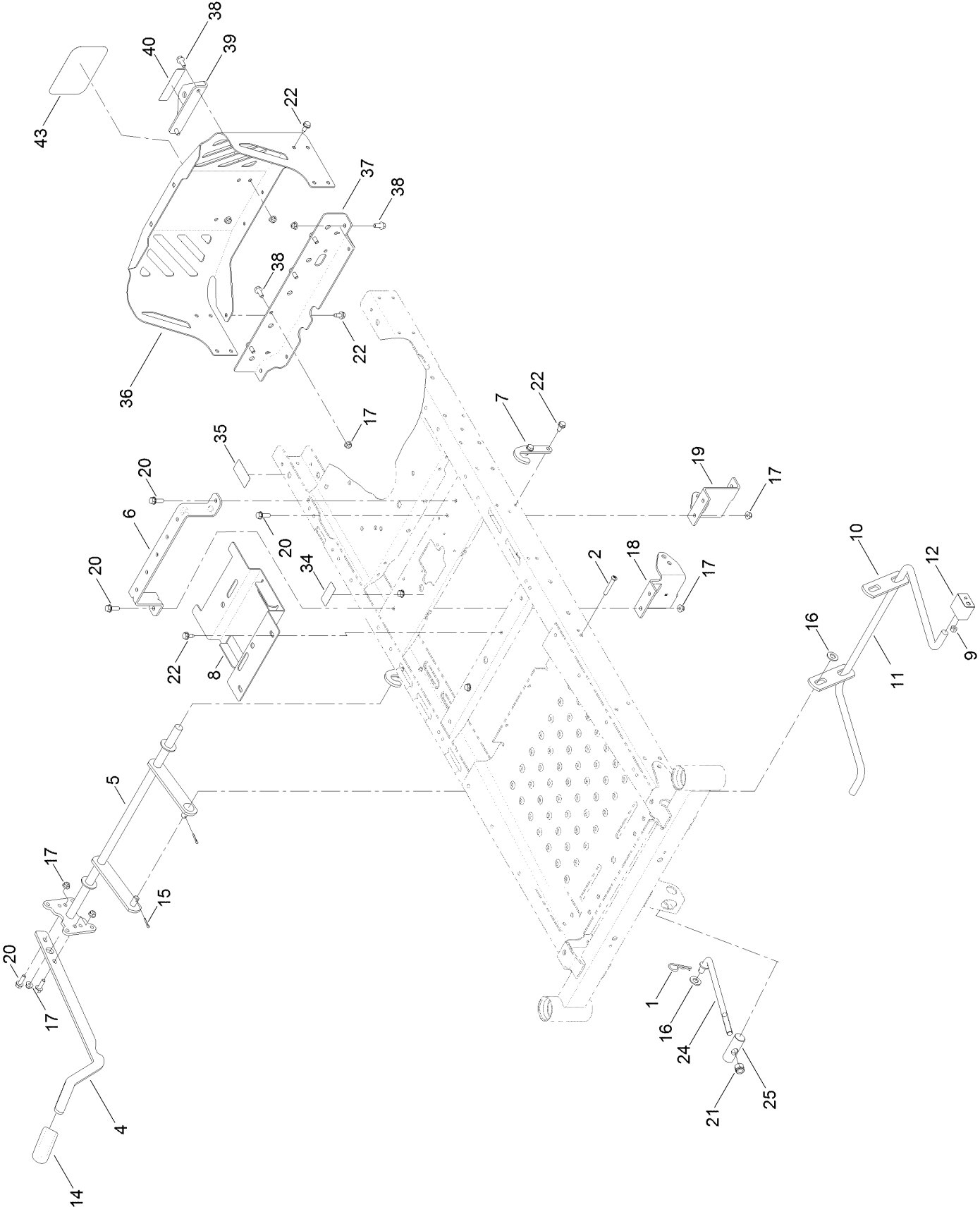

Deck Lift Assembly (continued)

<i>Ref.</i>	<i>Part Number</i>	<i>Qty.</i>	<i>Description</i>	<i>Ref.</i>	<i>Part Number</i>	<i>Qty.</i>	<i>Description</i>
1	1-806005	1	Pin-Cotter	18	131-0901-01	1	Mount-Hydro, Front Right
2	120-5499	2	Screw-HSBH	19	131-0902-01	1	Mount-Hydro, Front Left
4	119-3427-03	1	Lever-Lift	20	3234-29	6	Screw-HHF
5	117-7346-03	1	Lift-Deck	21	3296-19	1	Nut-Hex
6	119-3435-03	1	Brace-Seat, Rear	22	32144-70	16	Screw-HWHTF
7	119-8875	2	Bracket-Lift	24	131-3945	1	Rod-Mount, Deck
8	131-0914-03	1	Bracket-Battery	25	119-8810	1	Pin-Pivot
9	3296-29	2	Nut-Lock, NI	34	121-5684	1	Decal
10	108-7840	2	Link-Lift	35	121-2989	2	Decal-Bypass
11	108-7839	1	Arm-Lift, Rear	36	127-3353-03	1	Guard-Engine, Narrow
12	108-7845	2	Block-Pivot	37	130-6950-01	1	Crossmember-Rear, Narrow
14	1-633268	1	Grip-Lever	38	3234-47	8	Screw-HHF
15	3272-11	2	Pin-Cotter	39	117-1232-03	1	Bracket-Hitch
16	3256-26	3	Washer-Flat	40	131-4036	1	Decal
17	104-8300	14	Nut-Flange, NI	43	99-4693	1	Decal

Motion Control Assembly

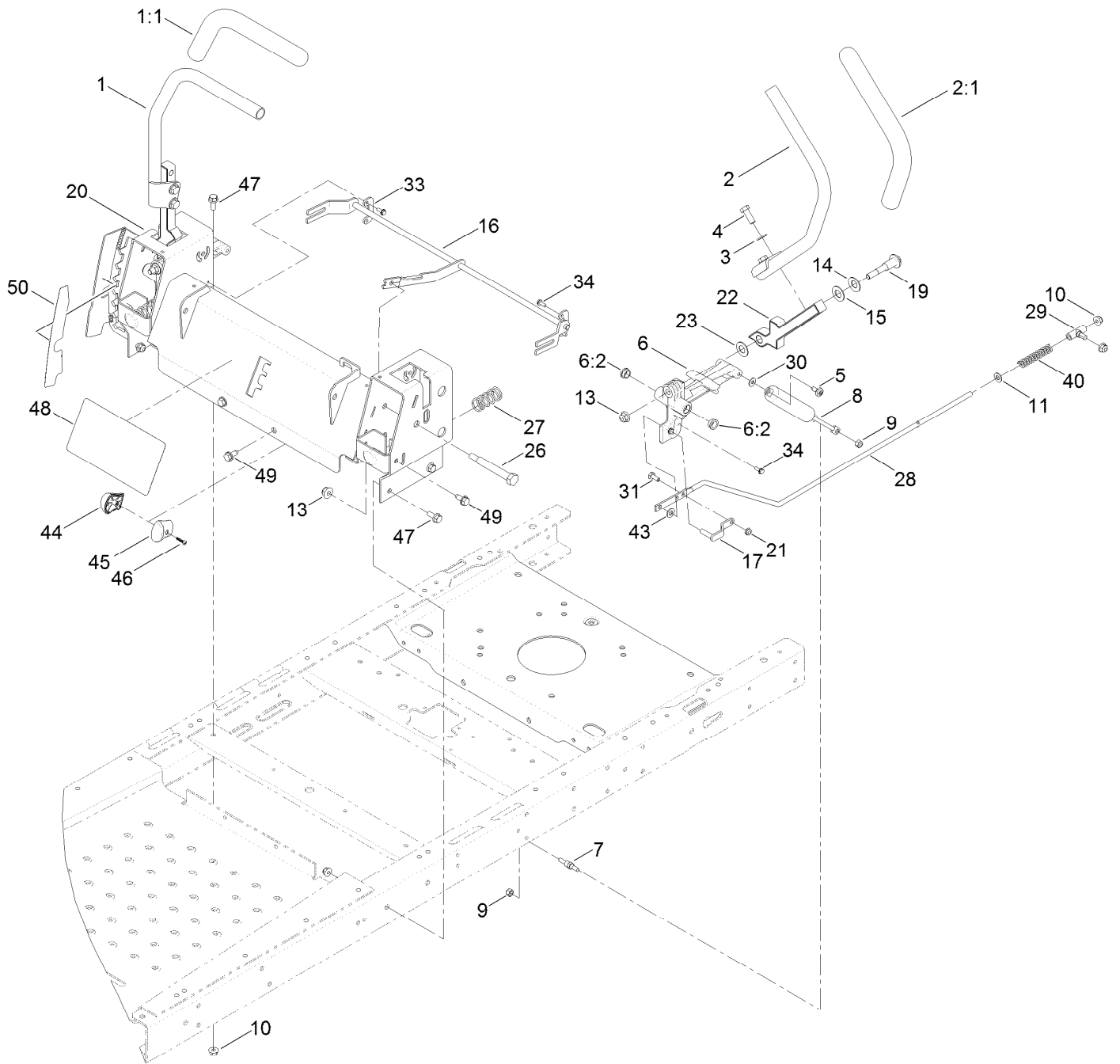

Motion Control Assembly (continued)

<i>Ref.</i>	<i>Part Number</i>	<i>Qty.</i>	<i>Description</i>	<i>Ref.</i>	<i>Part Number</i>	<i>Qty.</i>	<i>Description</i>
1	121-0731	1	Handle-Control, RH	21	3296-56	2	Nut-Lock, NI
1:1	121-0726	1	Grip	22	115-5098-05	2	Lever-Control
2	121-0730	1	Handle-Control, LH	23	120-2273	2	Washer-Nylon
2:1	121-0726	1	Grip	26	115-5099	2	Bolt-Pivot
3	3256-24	4	Washer-Flat	27	119-8876	2	Spring-Return
4	323-6	4	Screw-HH	28	117-5388	2	Rod-Hydro
5	120-7950	2	Screw-Shoulder	29	119-8842	2	Mount-Rod, Hydro
6	119-3470	2	Actuator Arm ASM	30	119-8952	2	Washer
6:2	256-156	2	Bushing-Flange	31	321-3	2	Screw-HH
7	110-6810	2	Stud-Damper	33	117-5385	2	Retainer
8	131-4132	2	Damper	34	32144-1	4	Screw-Taptite
9	3296-42	4	Nut-Lock, NI	40	1-603807	2	Spring-Return, Neutral
10	104-8300	10	Nut-Flange, NI	43	93-6079	2	Spacer-Nylon
11	3256-23	2	Washer-Flat	44	119-8935	1	Knob-RH
13	104-8301	4	Nut-Flange, NI	45	119-8936	1	Knob-LH
14	119-8925	2	Washer-Belleville	46	94-4496	1	Screw-PPH
15	117-1240	2	Washer	47	3234-47	6	Screw-HHF
16	131-1094	1	Speed Control ASM	48	131-3947	1	Decal-Speed Control
17	119-3303	2	Pin-Rod, Hydro	49	32144-70	4	Screw-HWHTF
19	117-1198	2	Bolt-Pivot	50	119-8871	1	Decal
20	131-1093-03	1	Control Box ASM				

Brake Assembly

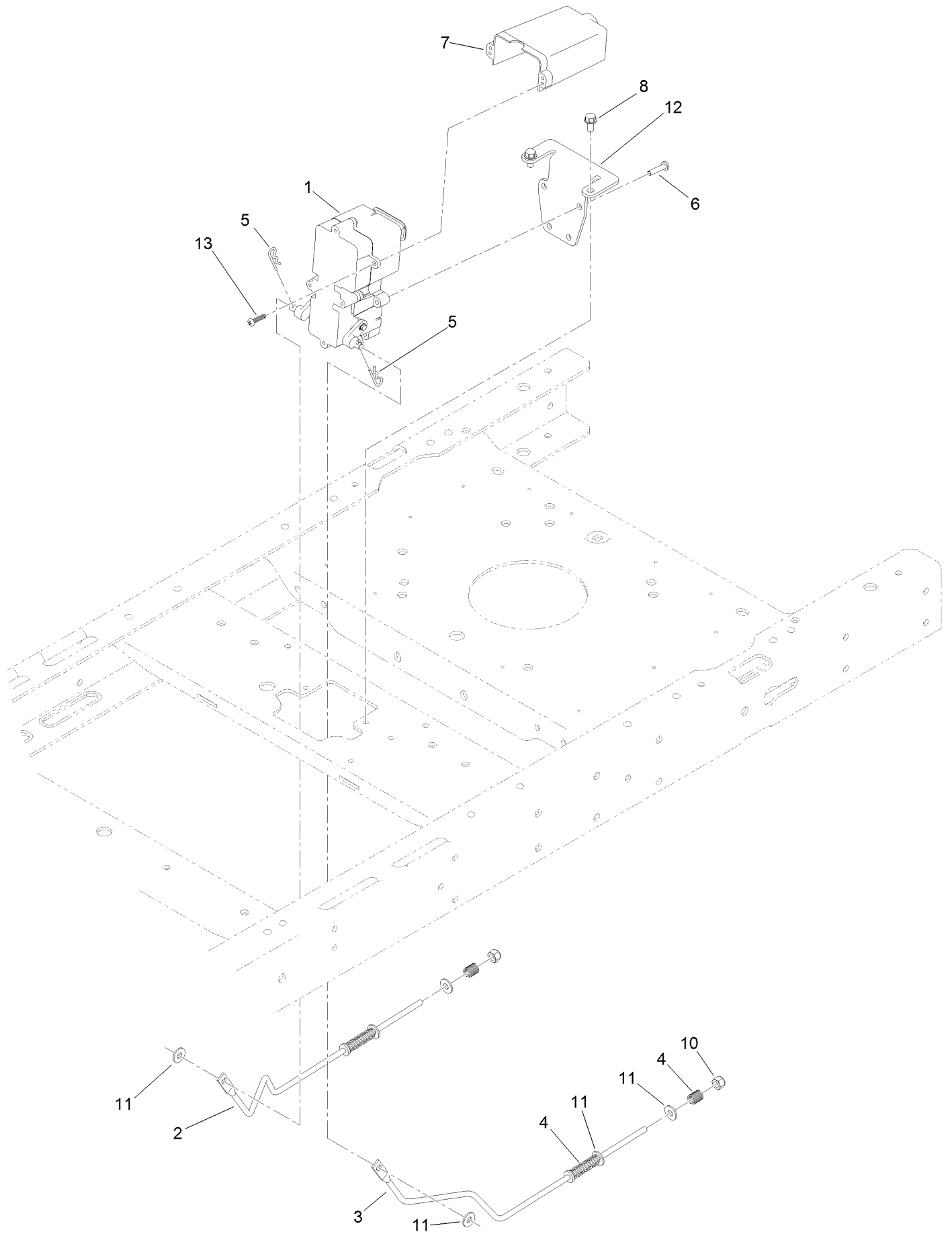

Brake Assembly (continued)

<i>Ref.</i>	<i>Part Number</i>	<i>Qty.</i>	<i>Description</i>	<i>Ref.</i>	<i>Part Number</i>	<i>Qty.</i>	<i>Description</i>
1	130-6892	1	Brake Box ASM	7	130-6974	1	Cover-Connector
2	121-2974	1	Rod-Brake, RH	8	32144-4	2	Screw-HWH
3	121-2975	1	Rod-Brake, LH	10	3296-42	2	Nut-Lock, NI
4	117-1169	4	Spring-Compression	11	119-8952	6	Washer
5	3290-307	2	Pin-Cotter	12	130-0790-03	1	Bracket-Mount, Brake
6	32144-36	4	Screw-PPH	13	94-4496	2	Screw-PPH

Seat Assembly

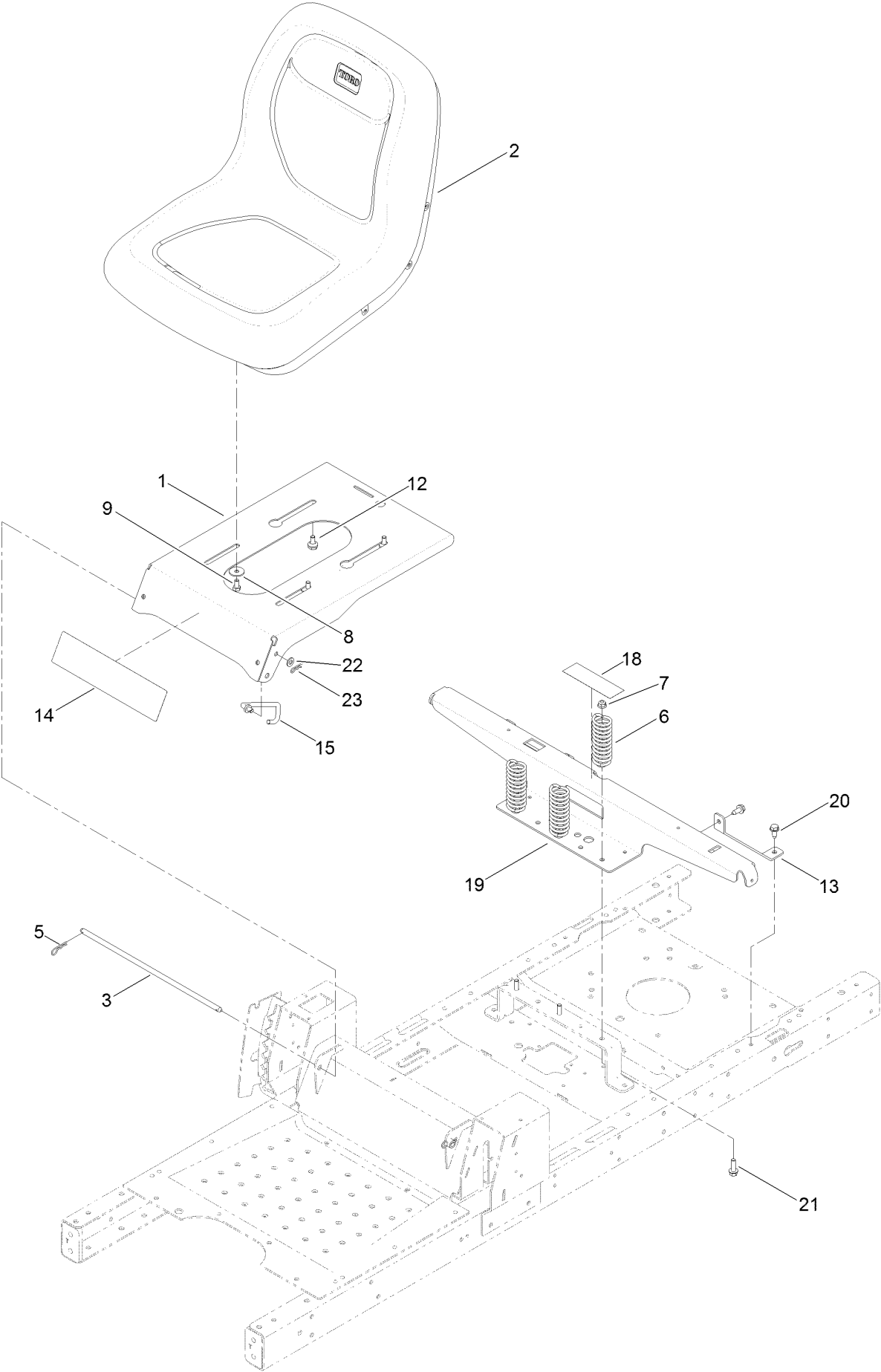

Seat Assembly (continued)

<i>Ref.</i>	<i>Part Number</i>	<i>Qty.</i>	<i>Description</i>	<i>Ref.</i>	<i>Part Number</i>	<i>Qty.</i>	<i>Description</i>
1	119-3391-01	1	Pan-Seat	13	119-3431-03	2	Support-Tank, Rear
2	119-8829	1	Seat-18 Inch	14	131-3649	1	Decal-Timecutter
3	119-3433	1	Rod-Pivot, Narrow	15	119-8972	1	Stop-Seat
5	3290-250	2	Pin-Cotter	18	106-8717	1	Decal-Service
6	92-7054	3	Spring-Compression	19	131-1040-03	1	Support-Pod
7	104-8300	3	Nut-Flange, NI	20	32144-70	4	Screw-HWHTF
8	5-4460	2	Washer-Pivot	21	3234-29	3	Screw-HHF
9	322-2	2	Screw-HH	22	3256-23	1	Washer-Flat
12	37-8771	2	Bolt-Shoulder	23	3290-307	1	Pin-Cotter

Belt and Idler Assembly

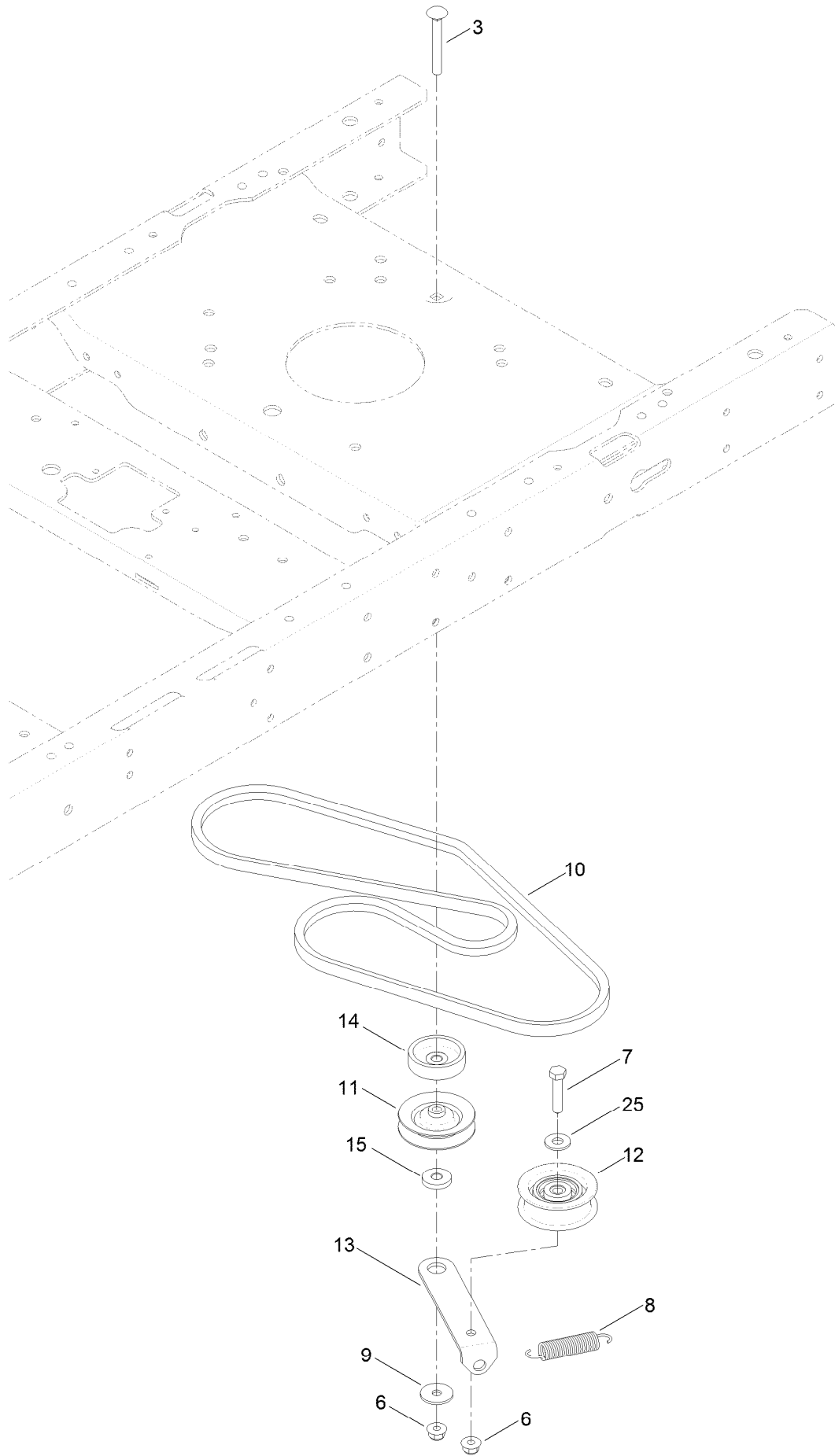

Belt and Idler Assembly (continued)

<i>Ref.</i>	<i>Part Number</i>	<i>Qty.</i>	<i>Description</i>	<i>Ref.</i>	<i>Part Number</i>	<i>Qty.</i>	<i>Description</i>
3	3230-8	1	Screw-CARR	11	119-8822	1	Pulley-Idler
6	104-8300	2	Nut-Flange, NI	12	106-2176	1	Pulley-Idler
7	322-7	1	Screw-HH	13	119-3326	1	Arm-Idler
8	104-6415	1	Spring-Return, Pedal	14	119-3353	1	Spacer
9	5-4460	1	Washer-Pivot	15	119-3327	1	Spacer-Arm, Idler
10	130-6975	1	V-Belt	25	3256-3	1	Washer-Flat

Hydro Transaxle Assembly

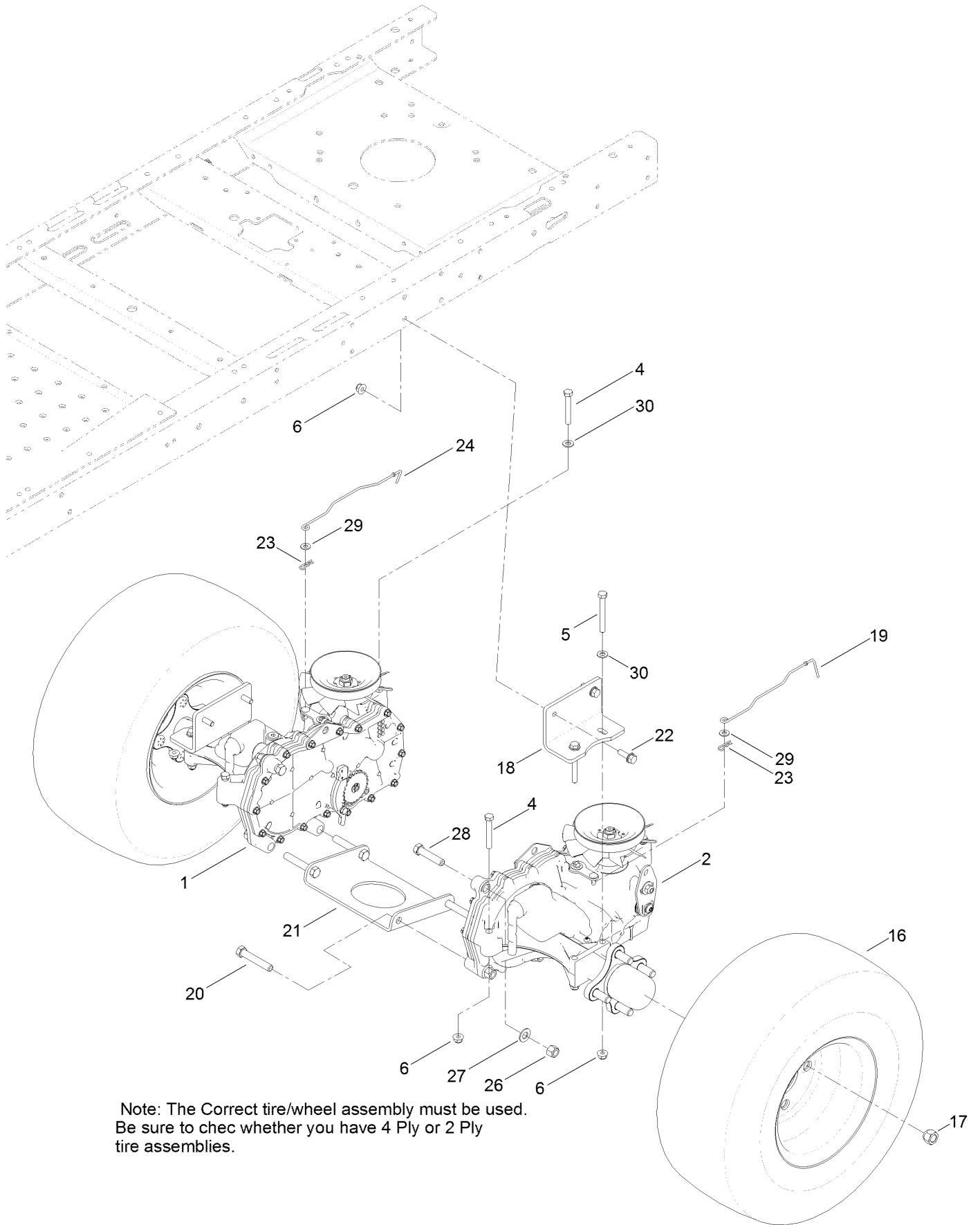

Note: The Correct tire/wheel assembly must be used.
Be sure to chec whether you have 4 Ply or 2 Ply
tire assemblies.

Hydro Transaxle Assembly (continued)

<i>Ref.</i>	<i>Part Number</i>	<i>Qty.</i>	<i>Description</i>	<i>Ref.</i>	<i>Part Number</i>	<i>Qty.</i>	<i>Description</i>
1	119-3331	1	RH Hydro Transaxle ASM	20	324-10	4	Screw-HH
2	119-3330	1	LH Hydro Transaxle ASM	21	119-3339-03	1	Plate-Cross, Hydro
4	322-11	4	Screw-HH	22	3234-29	4	Screw-HHF
5	322-13	4	Screw-HH	23	3290-307	2	Pin-Cotter
6	104-8300	12	Nut-Flange, NI	24	130-7049	1	Rod-Bypass, RH
16	119-3422	2	4 Ply Wheel And Tire ASM	26	3296-48	6	Nut-Lock, NI
16	131-3670	2	2 Ply Wheel And Wheel ASM	27	3256-25	6	Washer-Flat
17	242-50	8	Nut-Lug	28	324-8	2	Screw-HH
18	117-7264-03	2	Mount-Hydro	29	119-8952	2	Washer
19	131-0900	1	Rod-Bypass, LH	30	3256-23	6	Washer-Flat

4 Ply Wheel and Tire Assembly No. 119-3422

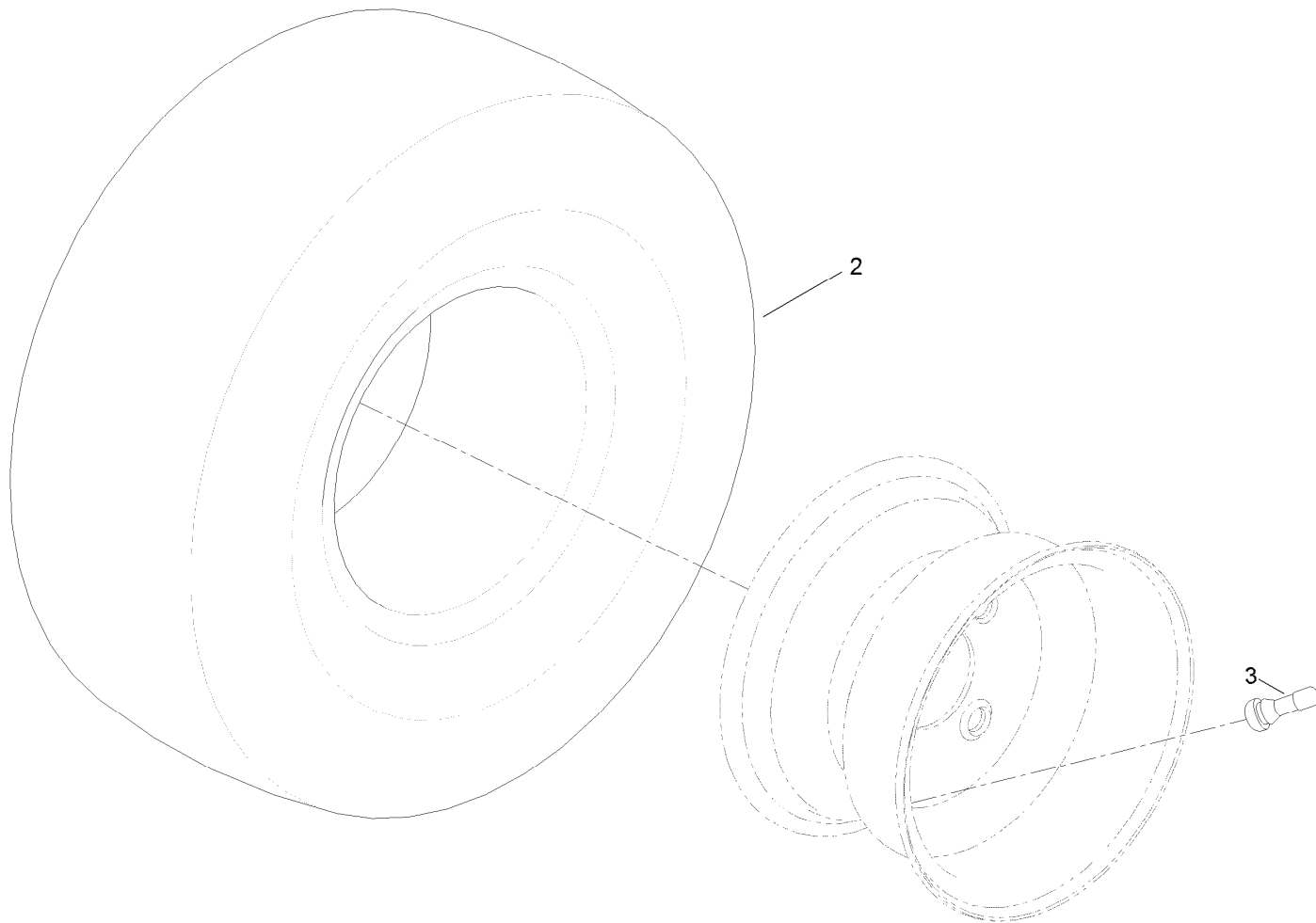

4 Ply Wheel and Tire Assembly No. 119-3422 (continued)

<i>Ref.</i>	<i>Part Number</i>	<i>Qty.</i>	<i>Description</i>
2	119-3421	1	Tire-4 Ply
3	232-27	1	Stem-Valve

2 Ply Wheel and Tire Assembly No. 131-3670

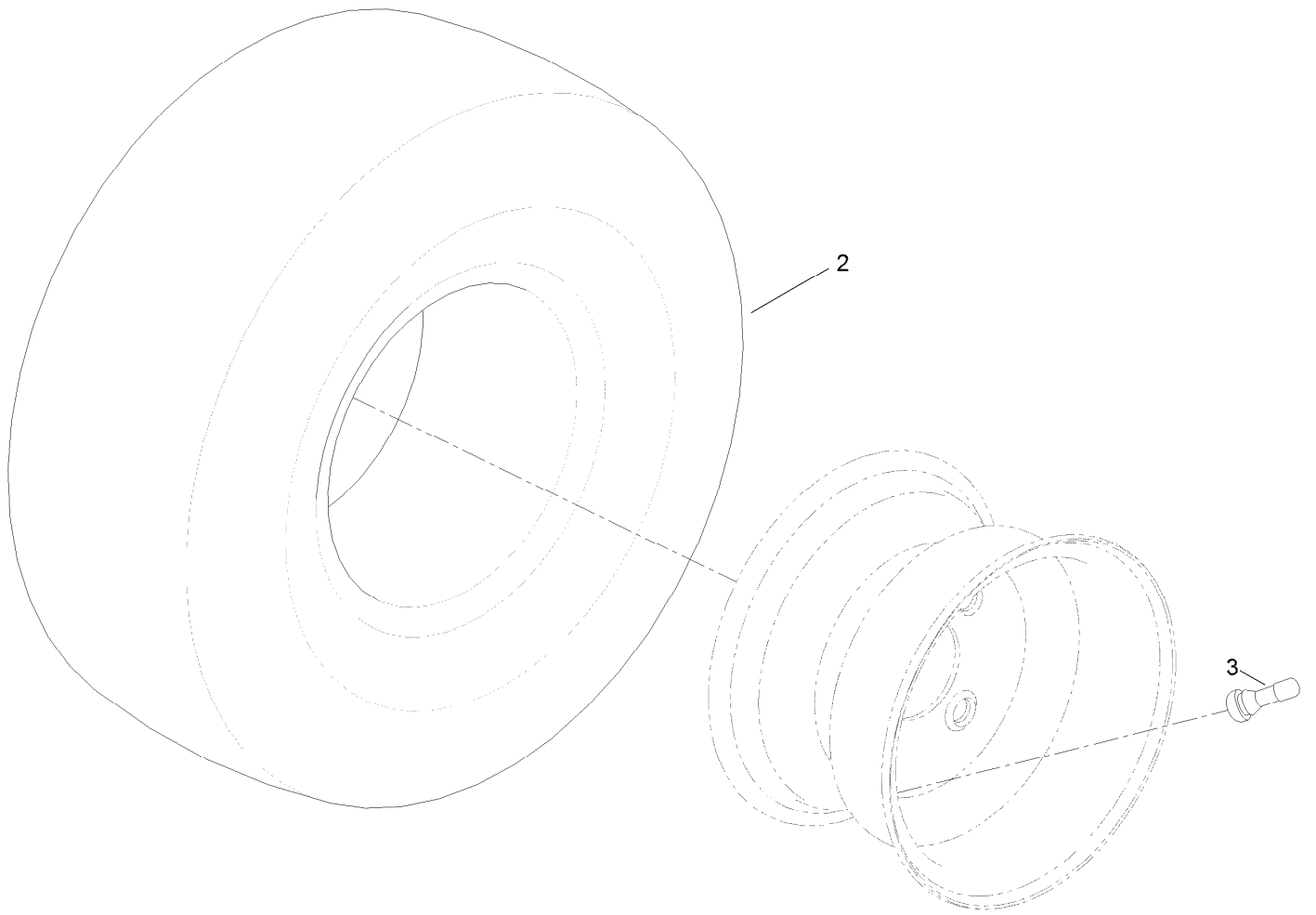

2 Ply Wheel and Tire Assembly No. 131-3670 (continued)

<i>Ref.</i>	<i>Part Number</i>	<i>Qty.</i>	<i>Description</i>
2	131-3677	1	Tire-2 Ply
3	232-27	1	Stem-Valve

Left Hand Hydro Transaxle Assembly No. 119-3330

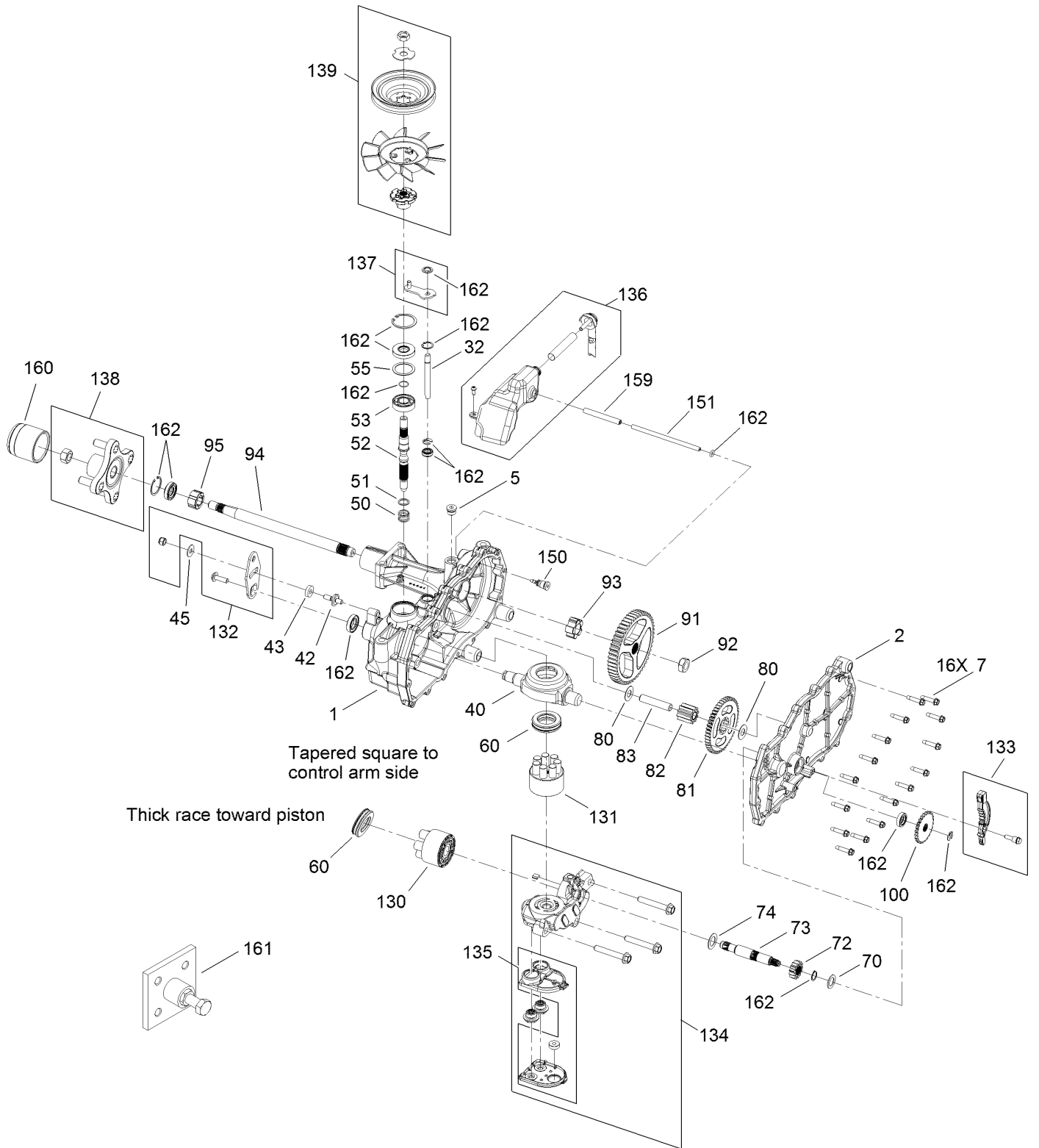

Left Hand Hydro Transaxle Assembly No. 119-3330 (continued)

<i>Ref.</i>	<i>Part Number</i>	<i>Qty.</i>	<i>Description</i>	<i>Ref.</i>	<i>Part Number</i>	<i>Qty.</i>	<i>Description</i>
1	120-5532	1	Main Housing ASM	83	104-5329	1	Pin-Jackshaft
2	120-5534	1	Housing Side Kit	91	120-5539	1	Gear-Bull
5	104-2189	1	Plug-Thread, Straight	92	104-2142	1	Nut-HJ
7	117-5359	16	Screw-HHF	93	115-8314	1	Bushing-Inboard
13	104-2147	1	Sealant ●	94	120-5540	1	Shaft-Axle
32	106-8678	2	Rod-Bypass	95	120-5541	1	Bearing-Sleeve
40	104-5304	1	Swashplate-Trunnion	100	106-8694	1	Disc-Brake, Cog
42	104-2116	1	Stud	130	103-2666	1	Cylinder Block Kit
43	112-9853	1	Puck-Friction	131	110-8561	1	Pump Block ASM
45	114-8491	1	Washer	132	117-5362	1	Arm Control Kit
50	120-5537	1	Spring-Compression	133	106-8688	1	Brake Arm Kit
51	120-5538	1	Washer	134	112-9861	1	Center Section Filter Kit
52	104-5306	1	Shaft-Input	135	114-1634	1	Filter Kit
53	104-5311	1	Bearing-Ball	136	121-5730	1	RH Expansion Tank Kit
55	104-5308	1	Spacer	137	120-5549	1	Bypass Kit
60	94-6922	1	Bearing-Thrust	138	121-5731	1	Hub Kit
70	104-5339	1	Washer-Flat	139	121-5729	1	Fan Pulley Kit
72	104-5316	1	Gear-Pinion, 13T	150	104-5349	1	Fitting-Sae
73	106-8683	1	Shaft-Motor	151	115-8302	1	Hose
74	104-5360	1	Washer	159	121-5728	1	Case-Tube
80	119-5541	2	Washer	160	125-0041	1	Cap-Axle
81	104-5317	1	Gear-10T/48T	161	114-8467	1	Hub-Puller, 4 Bolt
82	104-5318	1	Gear-Jackshaft, 10T	162	120-7103	1	Seal And Ring Kit

● Not illustrated

Right Hand Hydro Transaxle Assembly No. 119-3331

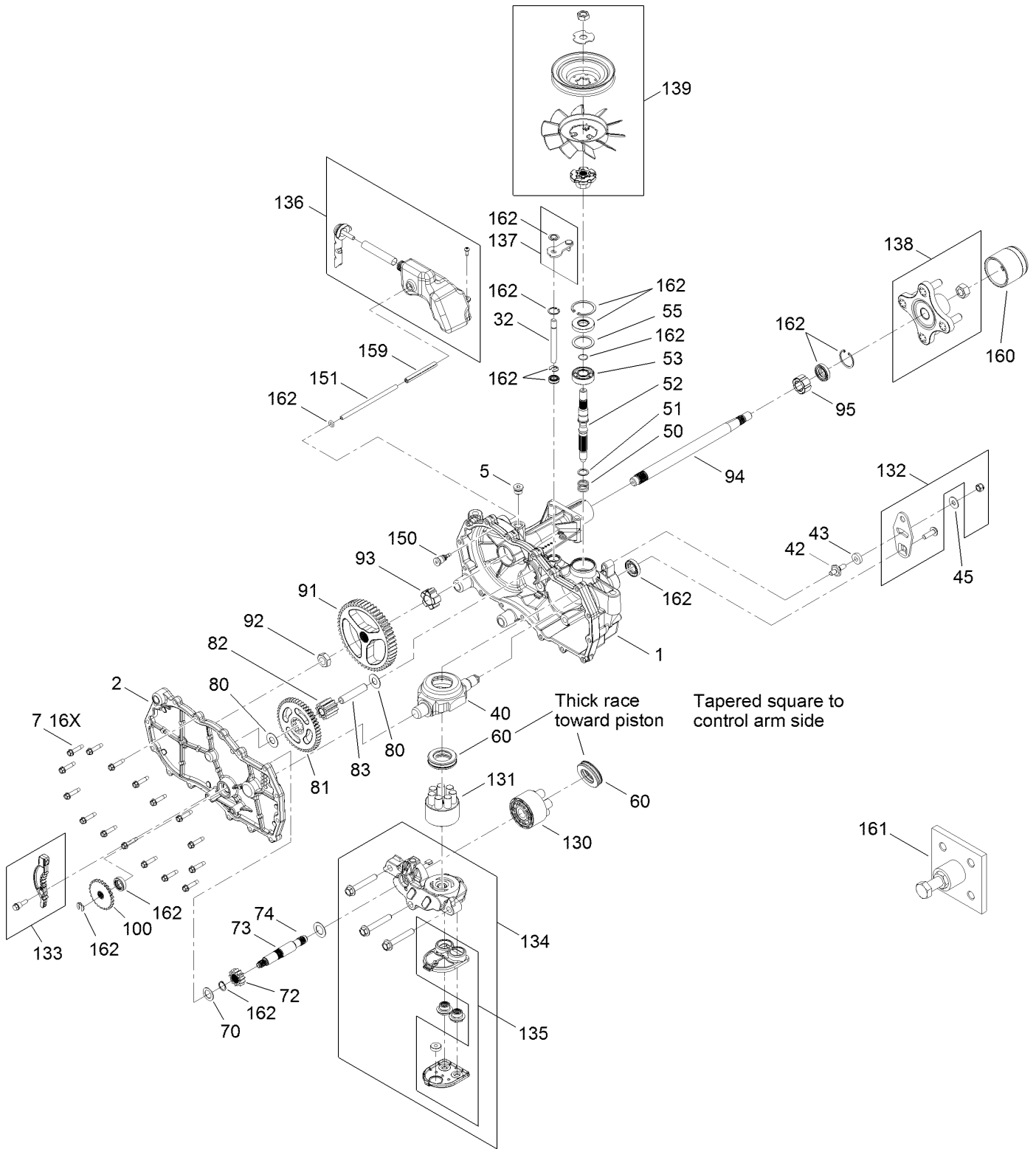

Right Hand Hydro Transaxle Assembly No. 119-3331 (continued)

<i>Ref.</i>	<i>Part Number</i>	<i>Qty.</i>	<i>Description</i>	<i>Ref.</i>	<i>Part Number</i>	<i>Qty.</i>	<i>Description</i>
1	120-5531	1	Main Housing ASM	83	104-5329	1	Pin-Jackshaft
2	120-5533	1	Housing Side Kit	91	120-5539	1	Gear-Bull
5	104-2189	1	Plug-Thread, Straight	92	104-2142	1	Nut-HJ
7	117-5359	16	Screw-HHF	93	115-8314	1	Bushing-Inboard
13	104-2147	1	Sealant ●	94	120-5540	1	Shaft-Axle
32	106-8678	2	Rod-Bypass	95	120-5541	1	Bearing-Sleeve
40	104-5304	1	Swashplate-Trunnion	100	106-8694	1	Disc-Brake, Cog
42	104-2116	1	Stud	130	103-2666	1	Cylinder Block Kit
43	112-9853	1	Puck-Friction	131	110-8561	1	Pump Block ASM
45	114-8491	1	Washer	132	117-5362	1	Arm Control Kit
50	120-5537	1	Spring-Compression	133	106-8688	1	Brake Arm Kit
51	120-5538	1	Washer	134	112-9862	1	Center Section Filter Kit
52	104-5306	1	Shaft-Input	135	114-1634	1	Filter Kit
53	104-5311	1	Bearing-Ball	136	121-5735	1	LH Expansion Tank Kit
55	104-5308	1	Spacer	137	107-2489	1	Bypass Arm Kit
60	94-6922	1	Bearing-Thrust	138	121-5731	1	Hub Kit
70	104-5339	1	Washer-Flat	139	121-5729	1	Fan Pulley Kit
72	104-5316	1	Gear-Pinion, 13T	150	104-5349	1	Fitting-Sae
73	106-8683	1	Shaft-Motor	151	115-8302	1	Hose
74	104-5360	1	Washer	159	121-5728	1	Case-Tube
80	119-5541	2	Washer	160	125-0041	1	Cap-Axle
81	104-5317	1	Gear-10T/48T	161	114-8467	1	Hub-Puller, 4 Bolt
82	104-5318	1	Gear-Jackshaft, 10T	162	120-7103	1	Seal And Ring Kit

● Not illustrated

Clutch Assembly

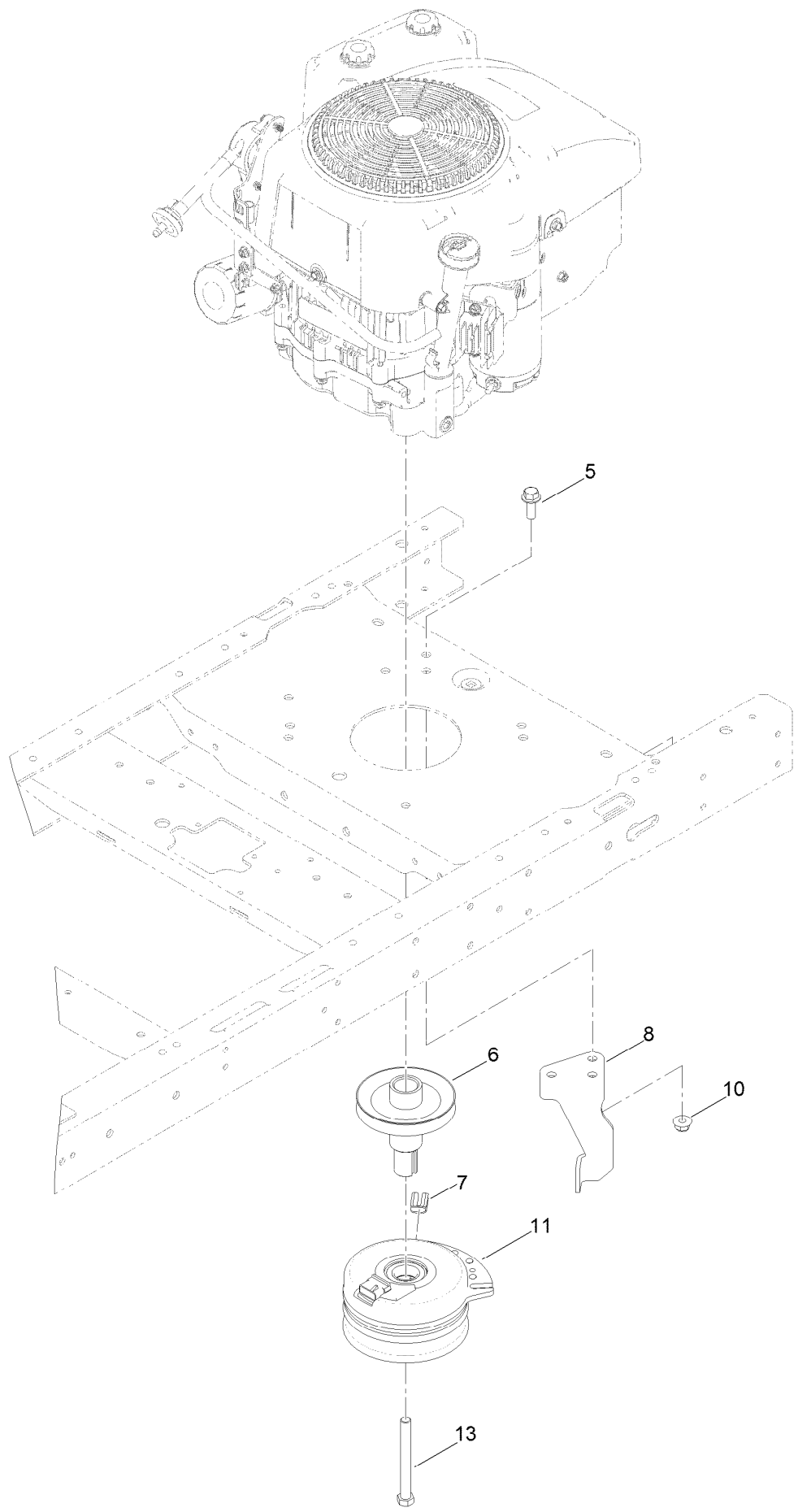

Clutch Assembly (continued)

<i>Ref.</i>	<i>Part Number</i>	<i>Qty.</i>	<i>Description</i>	<i>Ref.</i>	<i>Part Number</i>	<i>Qty.</i>	<i>Description</i>
5	3234-42	1	Screw-HHF	10	104-8301	1	Nut-Flange, NI
6	130-6854	1	Pulley-Engine	11	125-0038	1	Clutch-Electric
7	120-2217	1	Isolator-Clutch	13	3212-16	1	Screw-HH
8	119-8884	1	Stop-Clutch				

Engine and Muffler Assembly

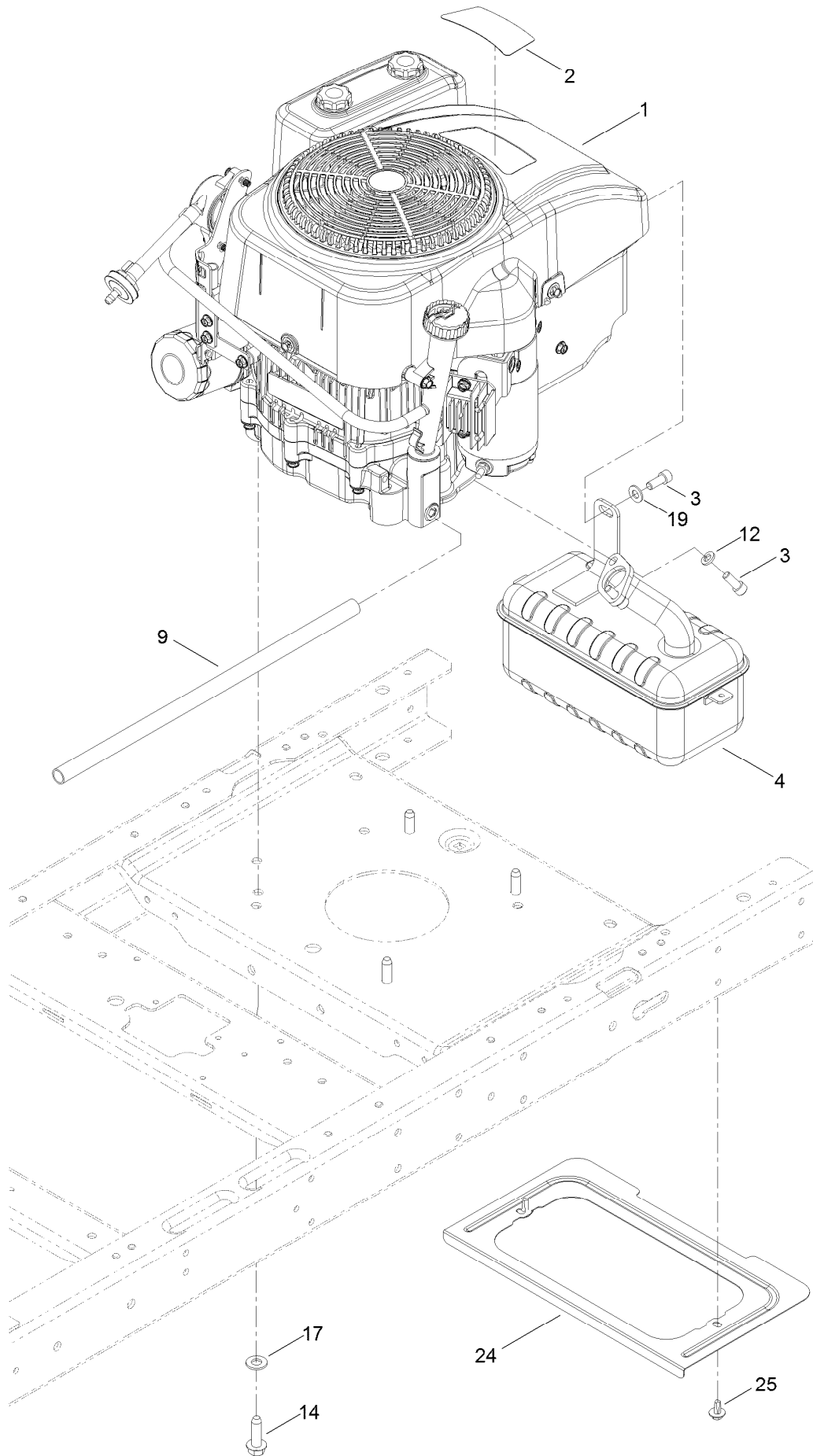

Engine and Muffler Assembly (continued)

<i>Ref.</i>	<i>Part Number</i>	<i>Qty.</i>	<i>Description</i>	<i>Ref.</i>	<i>Part Number</i>	<i>Qty.</i>	<i>Description</i>
1	121-0412	1	Engine-Lc1P92F-1	14	32144-109	4	Screw-Taptite
2	125-1700	1	Decal-Engine	17	3256-24	3	Washer-Flat
3	3274-10	3	Screw-HSH	19	3256-23	1	Washer-Flat
4	117-7412	1	Muffler	24	131-1071-03	1	Shield-Heat
9	106-7022	1	Tube-Drain, Oil	25	46-8560	2	Screw-HHFTF
12	3253-4	2	Washer-Lock				

Air Intake and Filtration Engine Assembly No. 121-0412

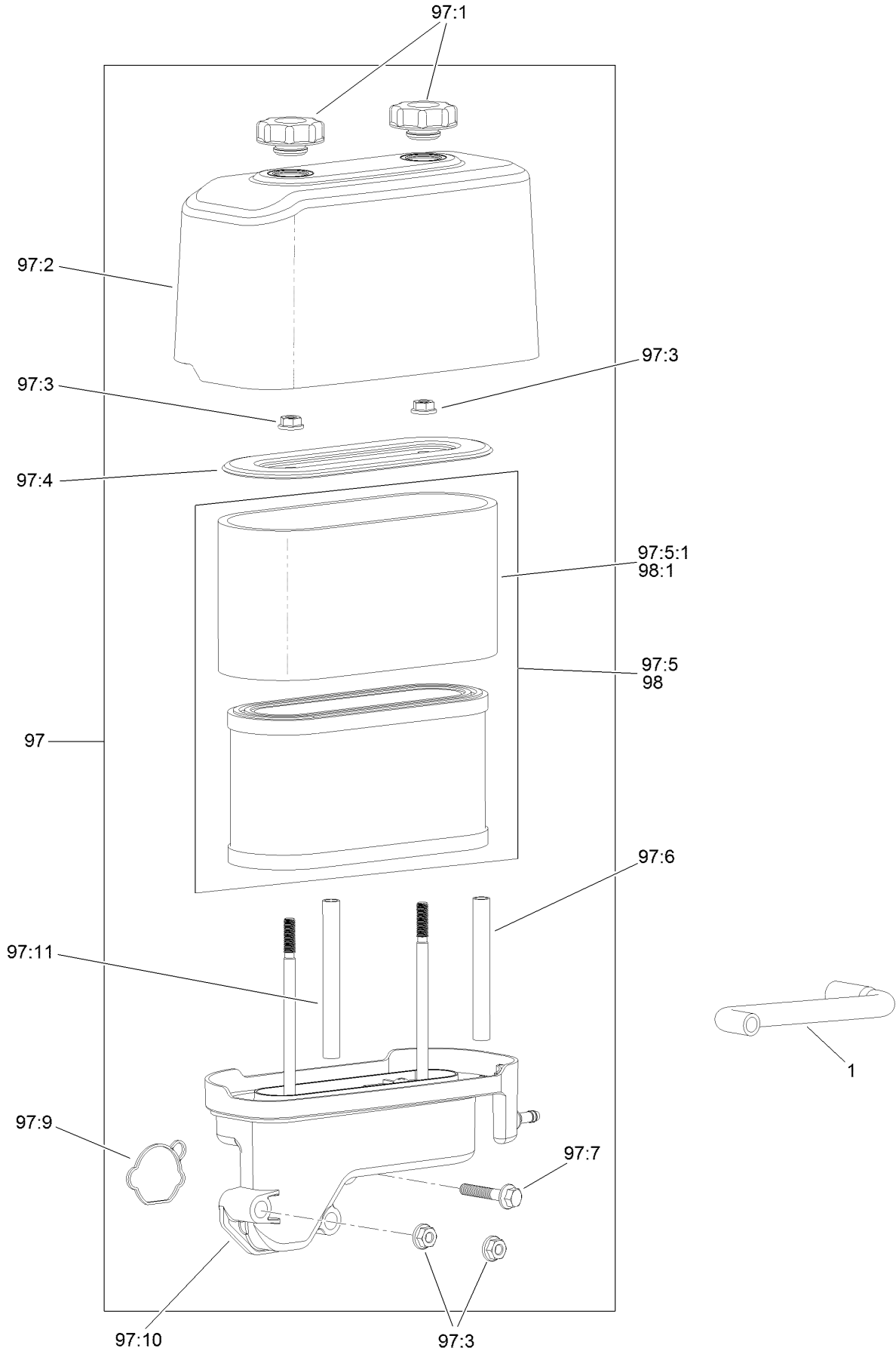

Air Intake and Filtration

Engine Assembly No. 121-0412 (continued)

<i>Ref.</i>	<i>Part Number</i>	<i>Qty.</i>	<i>Description</i>	<i>Ref.</i>	<i>Part Number</i>	<i>Qty.</i>	<i>Description</i>
1	120-4255	1	Tube-Breather	97:6	120-4333	1	Spacer-Filter, Air
97	127-9186	1	Air Cleaner Kit	97:7	120-4284	1	Screw-HHF
97:1	120-4312	2	Nut-Speed	97:9	127-9185	1	Gasket-Carburetor
97:2	120-4311	1	Cover-Filter, Air	97:10	127-9191	1	Base-Filter, Air
97:3	120-4236	4	Nut-Flange	97:11	120-4334	1	Spacer-Filter, Air
97:4	120-4310	1	Retainer-Air Filter	98	127-9193	1	Air Filter Kit
97:5	127-9193	1	Air Filter Kit	98:1	120-4309	1	Prefilter
97:5:1	120-4309	1	Prefilter				

Fuel System Assembly Engine Assembly No. 121-0412

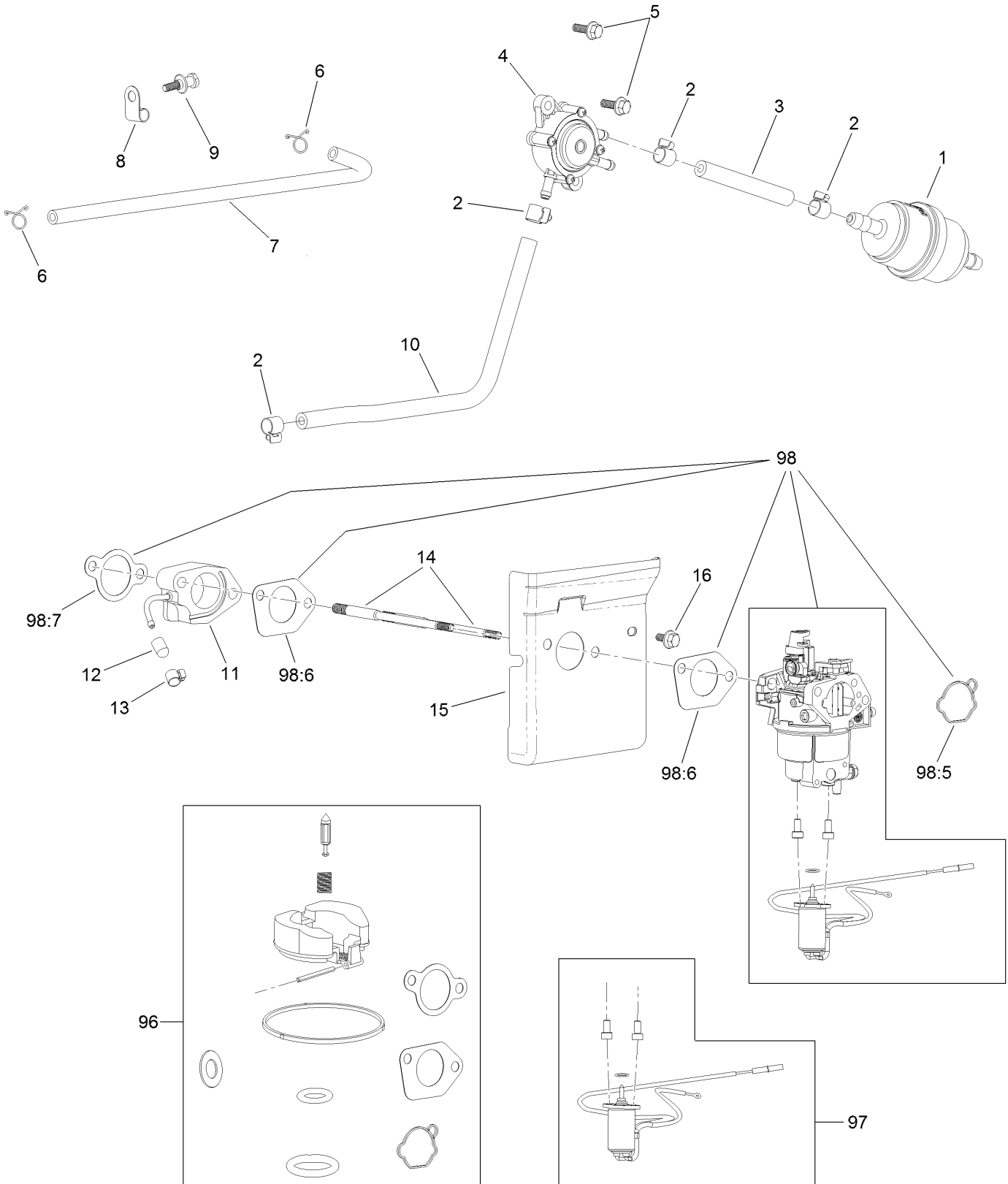

Fuel System Assembly

Engine Assembly No. 121-0412 (continued)

<i>Ref.</i>	<i>Part Number</i>	<i>Qty.</i>	<i>Description</i>	<i>Ref.</i>	<i>Part Number</i>	<i>Qty.</i>	<i>Description</i>
1	127-9204	1	Filter-Fuel	13	127-9187	1	Clamp-Hose
2	120-4251	4	Clamp-Fuel Line	14	120-4202	2	Stud-Mount, Carburetor
3	120-4371	1	Line-Fuel	15	127-9182	1	Shroud
4	120-4353	1	Pump-Pulse, Fuel	16	120-4216	1	Screw-HHF
5	120-4232	2	Screw-HHF	96	127-9194	1	Carb Repair Kit With Gaskets
6	121-0114	2	Clamp-Hose	97	127-9190	1	Solenoid Kit
7	120-4372	1	Line-Pulse	98	127-9183	1	Carburetor Kit
8	120-4287	1	Clamp-J	98:5	127-9185	1	Gasket-Carburetor
9	120-4217	1	Screw-Shoulder, HH	98:6	120-4247	2	Gasket-Carburetor
10	120-4370	1	Line-Fuel	98:7	120-4250	1	Gasket-Carburetor
11	127-9181	1	Insulator-Carburetor	99	127-9362	1	High Altitude Kit (1P92)●
12	127-9189	1	Cap-Seal				

● Not illustrated

Ignition and Electrical Assembly Engine Assembly No. 121-0412

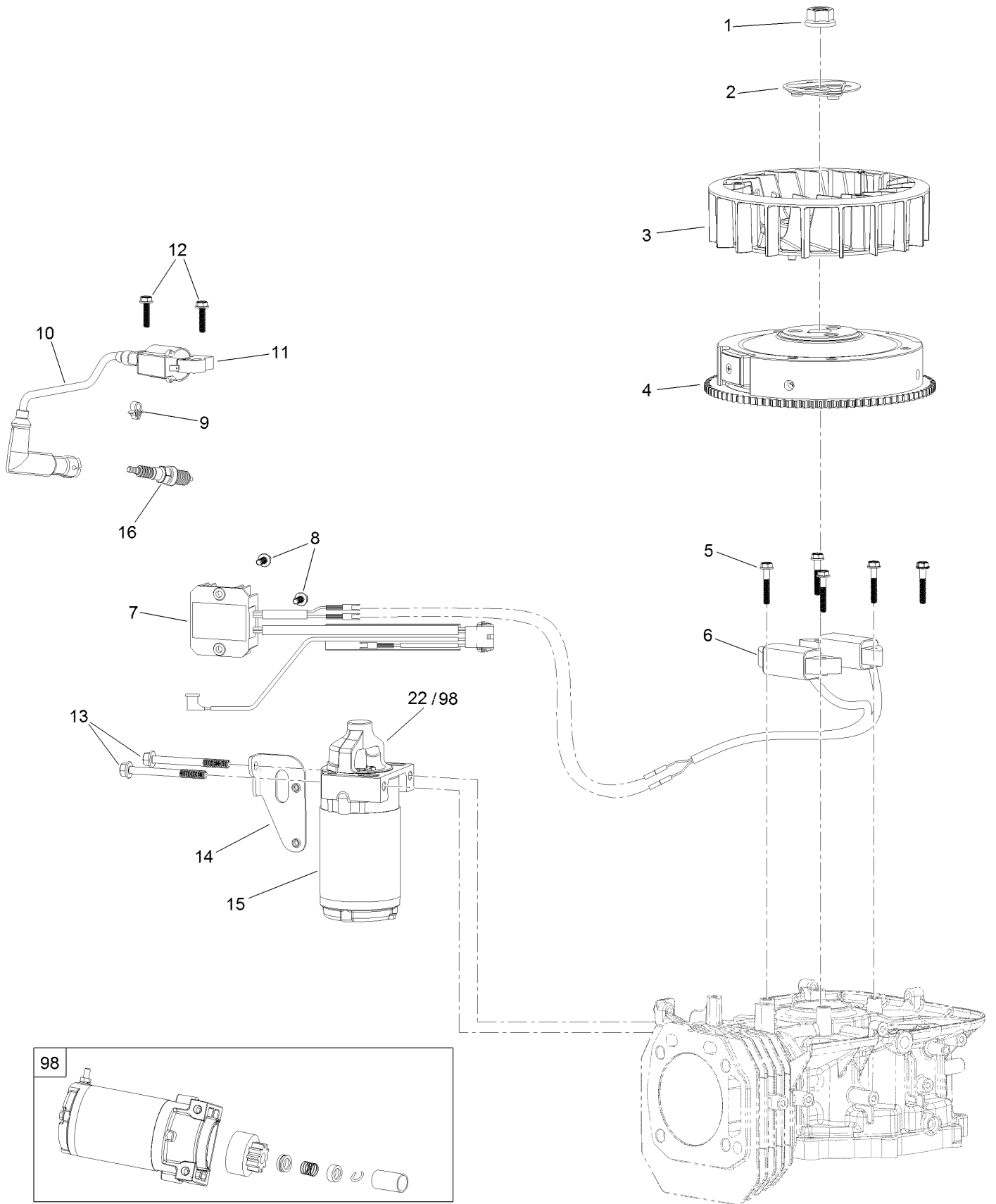

Ignition and Electrical Assembly Engine Assembly No. 121-0412 (continued)

<i>Ref.</i>	<i>Part Number</i>	<i>Qty.</i>	<i>Description</i>	<i>Ref.</i>	<i>Part Number</i>	<i>Qty.</i>	<i>Description</i>
1	120-4213	1	Nut-Flange	10	120-4226	1	Boot-Plug, Spark
2	120-4212	1	Pulley-Starter	11	127-9177	1	Ignition Coil ASM
3	120-4211	1	Fan-Cooling	12	120-4225	2	Screw-HHF
4	120-4399	1	Flywheel	13	120-4231	2	Screw-HHF
5	120-4223	4	Screw-HHF	14	120-4230	1	Bracket-Starter
6	127-9176	1	Alternator	15	120-4339	1	Starter-Electric
7	127-9178	1	Voltage Regulator	16	120-4204	1	Plug-Spark
8	120-4216	3	Screw-HHF	22	120-4398	1	Pinion
9	120-4316	1	Clamp-Wire	98	120-4392	1	Starter Repair Kit

Crankcase Assembly Engine Assembly No. 121-0412

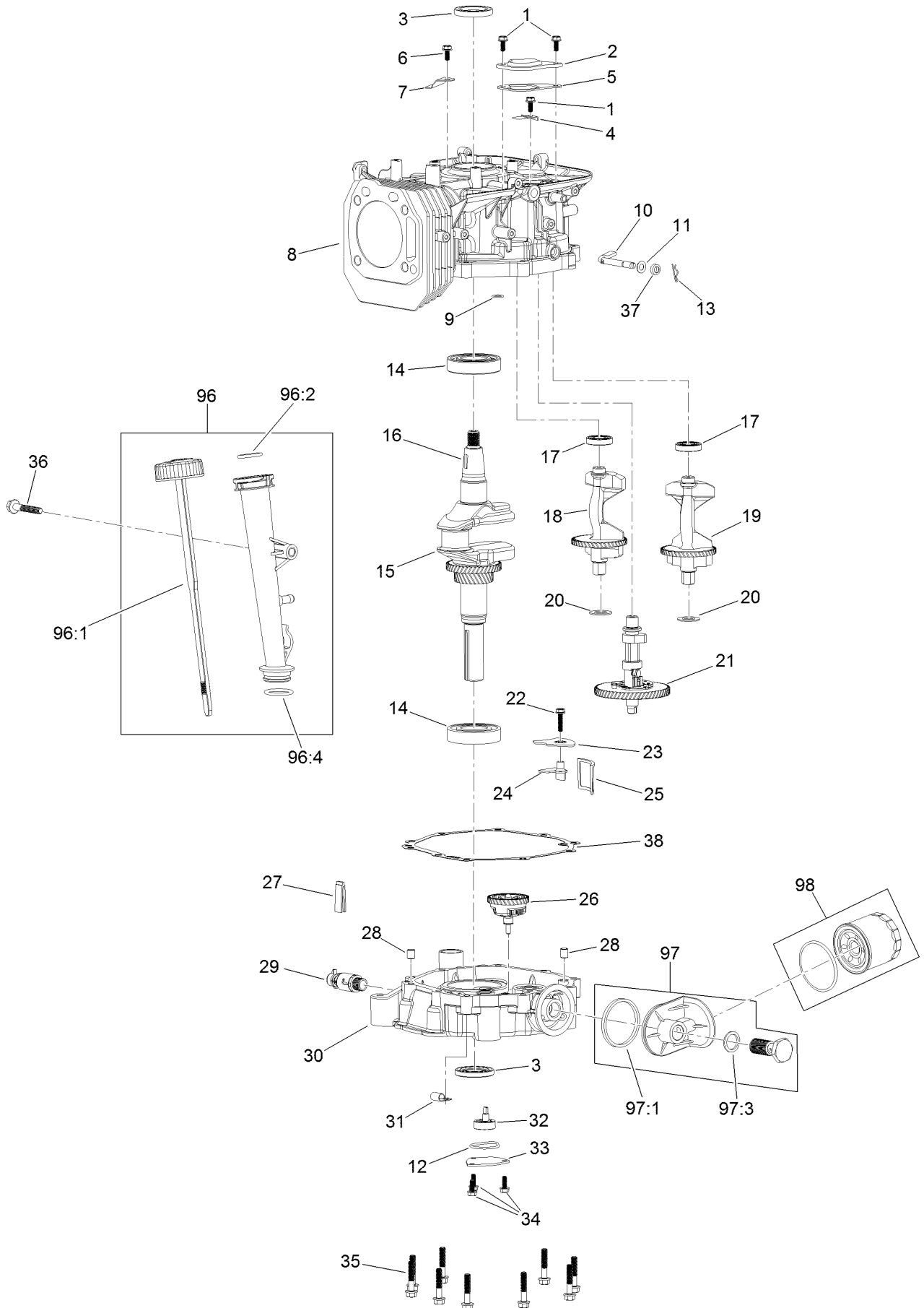

Crankcase Assembly Engine Assembly No. 121-0412 (continued)

<i>Ref.</i>	<i>Part Number</i>	<i>Qty.</i>	<i>Description</i>	<i>Ref.</i>	<i>Part Number</i>	<i>Qty.</i>	<i>Description</i>
1	120-4216	3	Screw-HHF	24	120-4279	1	Plate-Baffle, Oil
2	120-4265	1	Plate-Breather	25	120-4341	1	Strainer-Oil
3	120-4267	2	Seal-Oil	26	120-4338	1	Gear-Governor
4	120-4263	1	Valve-Reed	27	120-4275	1	Deflector-Oil, Rubber
5	120-4264	1	Gasket-Breather	28	120-4274	2	Pin-Dowel
6	120-4234	1	Screw-HHF	29	120-4321	1	Valve-Drain, Oil
7	120-4268	1	Retainer	30	120-4327	1	Cover-Crankcase
8	120-4336	1	Crankcase	31	127-9188	1	Clamp-Hose
9	120-4262	1	O-Ring	32	120-4344	1	Oil Pump ASM
10	120-4382	1	Shaft-Governor	33	120-4270	1	Cover-Pump, Oil
11	120-4258	1	Washer-Plain	34	120-4232	3	Screw-HHF
12	120-4343	1	Seal-Pump, Oil	35	120-4273	10	Screw-HHF
13	120-4256	1	Pin-Hair	36	120-4284	1	Screw-HHF
14	120-4261	2	Bearing-Ball	37	120-4257	1	Seal-Oil
15	120-4293	1	Crankshaft	38	120-4260	1	Gasket-Crankcase
16	120-4320	1	Key-Woodruff	96	120-4355	1	Dipstick And Tube Kit
17	120-4266	2	Bearing-Ball	96:1	120-4350	1	Dipstick ASM
18	127-9179	1	Shaft-Balance, R	96:2	120-4348	1	O-Ring
19	127-9180	1	Shaft-Balance, L	96:4	120-4282	1	O-Ring
20	120-4295	2	Washer	97	120-4363	1	Oil Adaptor Kit
21	120-4297	1	Camshaft	97:1	120-4362	1	Seal-Adaptor, Oil
22	120-4225	1	Screw-HHF	97:3	120-4360	1	Washer-Filter, Oil
23	120-4342	1	Cover-Strainer, Oil	98	120-4276	1	Filter-Oil

Piston and Cylinder Head Assembly

Engine Assembly No. 121-0412

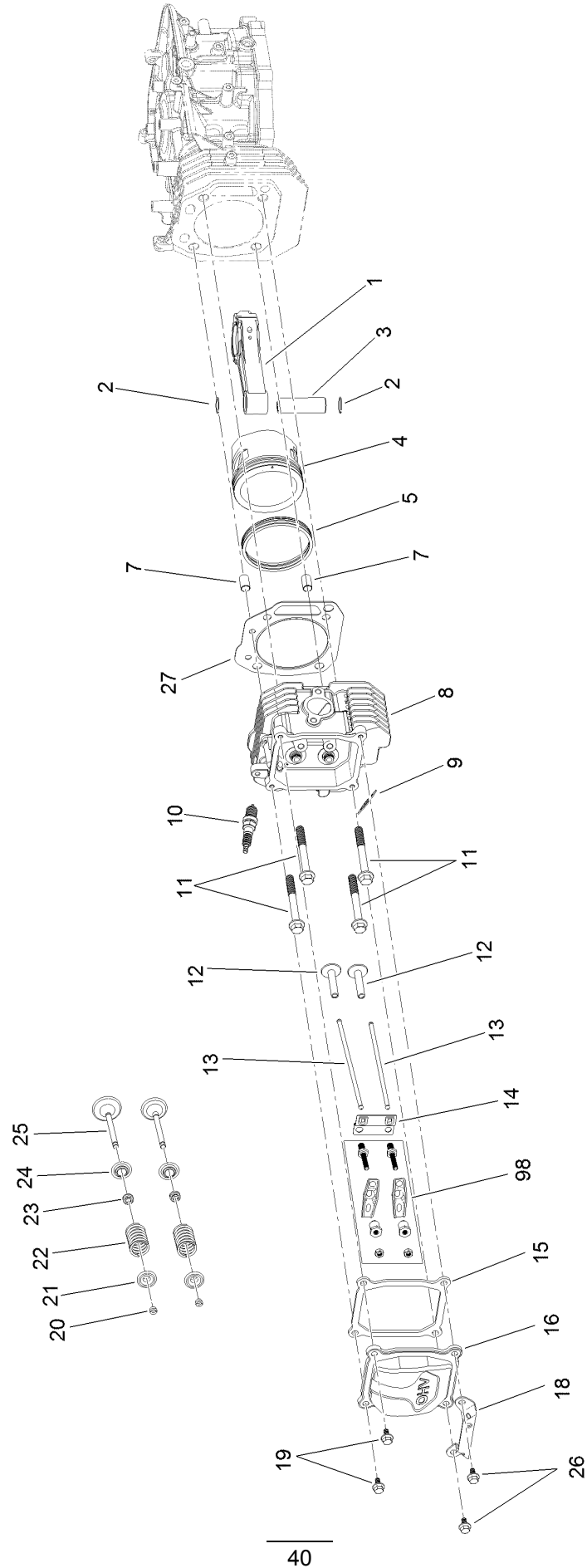

Piston and Cylinder Head Assembly Engine Assembly No. 121-0412 (continued)

<i>Ref.</i>	<i>Part Number</i>	<i>Qty.</i>	<i>Description</i>	<i>Ref.</i>	<i>Part Number</i>	<i>Qty.</i>	<i>Description</i>
1	120-4292	1	Connecting Rod ASM	15	120-4206	1	Gasket-Cover, Valve
2	120-4288	2	Ring-Retaining, Piston Pin	16	120-4207	1	Cover-Valve
3	120-4291	1	Pin-Piston	18	120-4345	1	Bracket-Muffler
4	120-4290	1	Piston	19	120-4209	2	Screw-Shoulder, HHF
5	120-4289	1	Ring Set	20	120-4307	2	Keeper-Valve
7	120-4200	2	Pin-Dowel	21	120-4306	2	Retainer-Spring, Valve
8	120-4203	1	Head-Cylinder	22	120-4305	2	Spring-Valve
9	120-4317	1	Gasket-Exhaust	23	120-4304	2	Seal-Stem, Valve
10	120-4204	1	Plug-Spark	24	120-4303	2	Seat-Spring, Valve
11	120-4205	4	Screw-HHF	25	120-4302	2	Valve Set
12	120-4298	2	Lifter-Valve	26	120-4210	2	Screw-Shoulder, HHF
13	120-4340	2	Rod-Push	27	120-4201	1	Gasket-Cylinder
14	120-4300	1	Plate	98	120-4301	1	Rocker Arm Kit

Governor Control Engine Assembly No. 121-0412

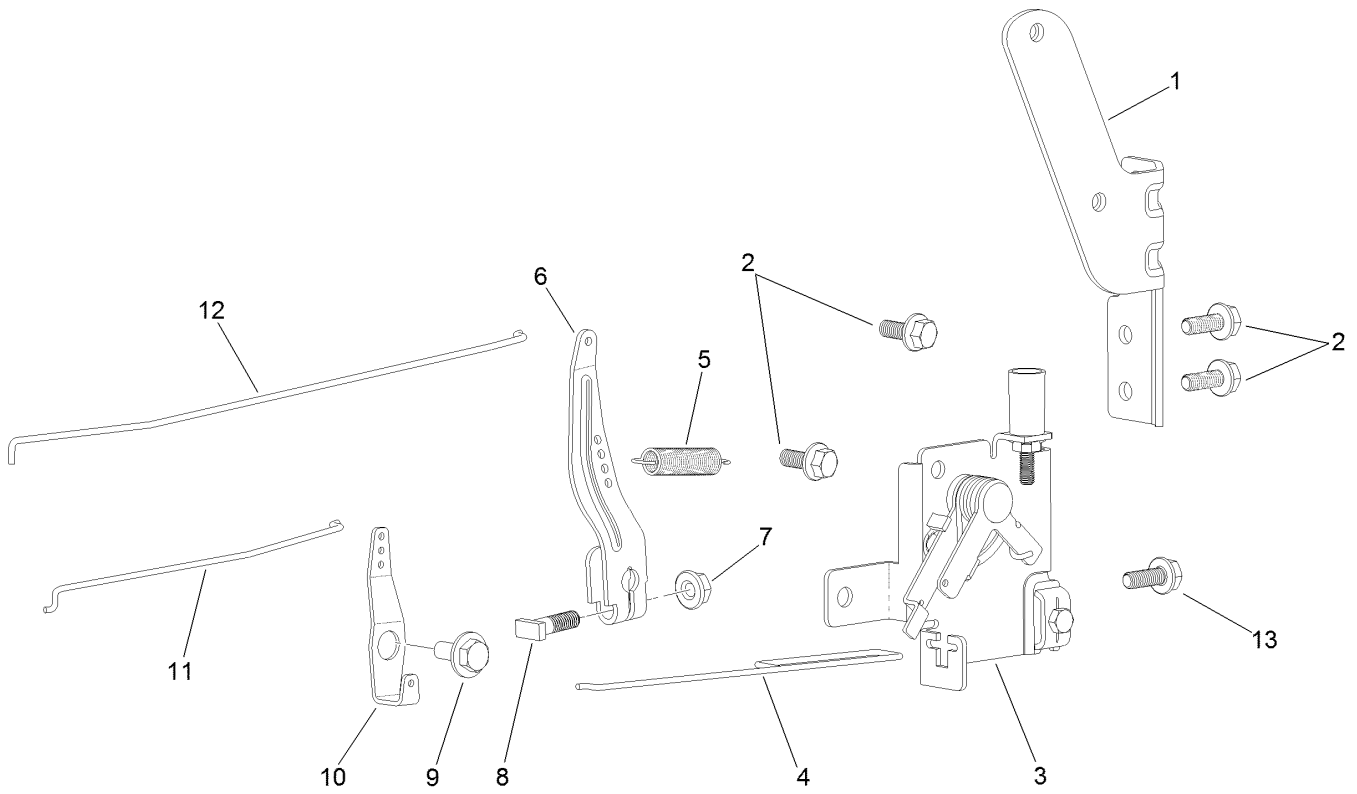

Governor Control Engine Assembly No. 121-0412 (continued)

<i>Ref.</i>	<i>Part Number</i>	<i>Qty.</i>	<i>Description</i>	<i>Ref.</i>	<i>Part Number</i>	<i>Qty.</i>	<i>Description</i>
1	120-4357	1	Bracket-Pump, Fuel	8	120-4238	1	Bolt-Arm, Governor
2	120-4234	4	Screw-HHF	9	120-4241	1	Screw-Shoulder, HHF
3	120-4358	1	Control-Throttle	10	120-4242	1	Bellcrank-Choke
4	120-4243	1	Rod-Throttle	11	120-4240	1	Rod-Choke
5	120-4337	1	Spring-Governor	12	120-4239	1	Rod-Governor
6	120-4352	1	Arm-Governor	13	120-4232	1	Screw-HHF
7	120-4236	1	Nut-Flange				

Blower Housing Assembly Engine Assembly No. 121-0412

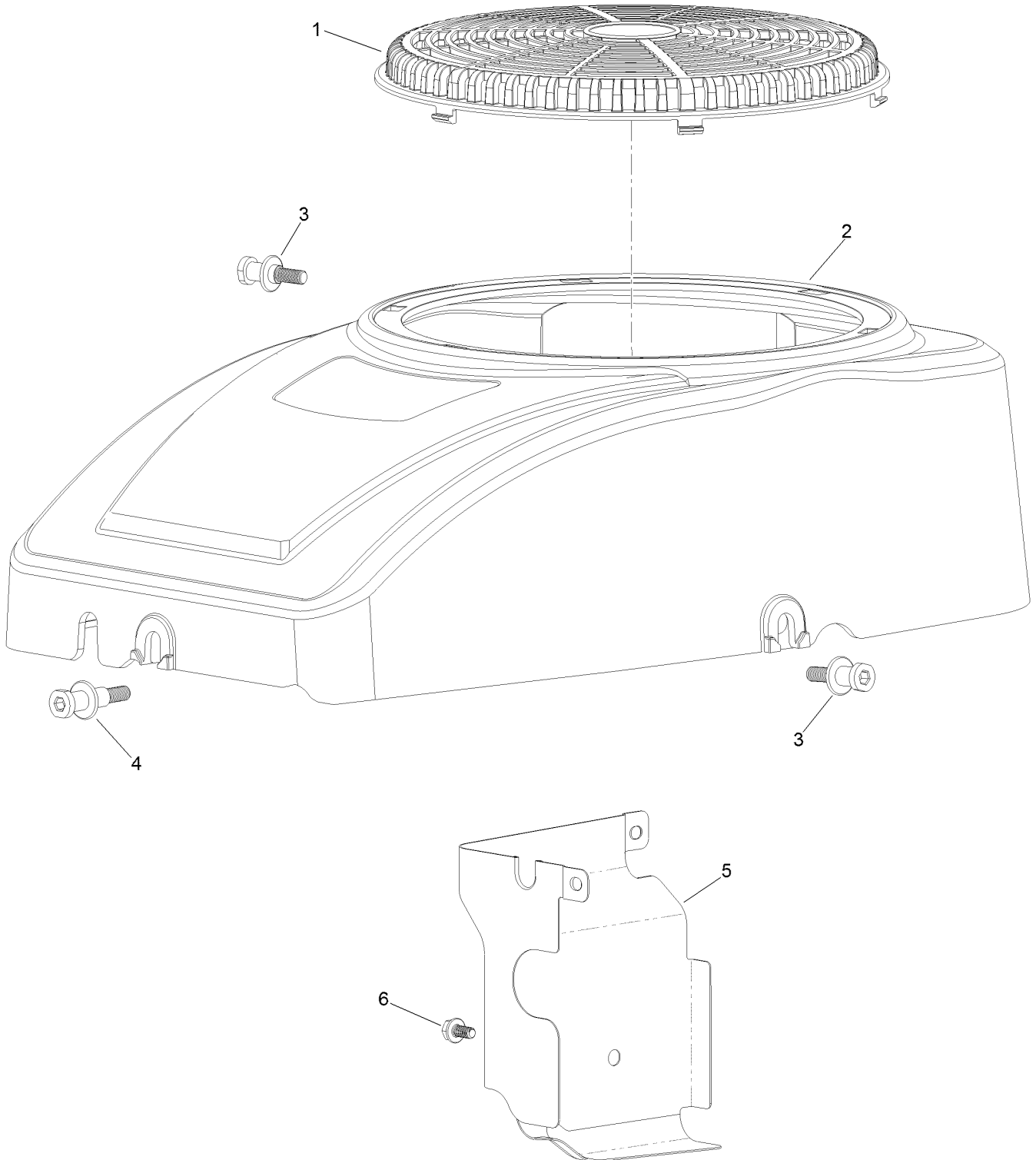

Blower Housing Assembly Engine Assembly No. 121-0412 (continued)

<i>Ref.</i>	<i>Part Number</i>	<i>Qty.</i>	<i>Description</i>	<i>Ref.</i>	<i>Part Number</i>	<i>Qty.</i>	<i>Description</i>
1	120-4219	1	Screen-Stationary	4	120-4214	1	Screw-Shoulder, HH
2	120-4218	1	Shroud-Fan	5	120-4215	1	Shield
3	120-4217	2	Screw-Shoulder, HH	6	120-4216	1	Screw-HHF

Gasket and Seal Kit Engine Assembly No. 121-0412

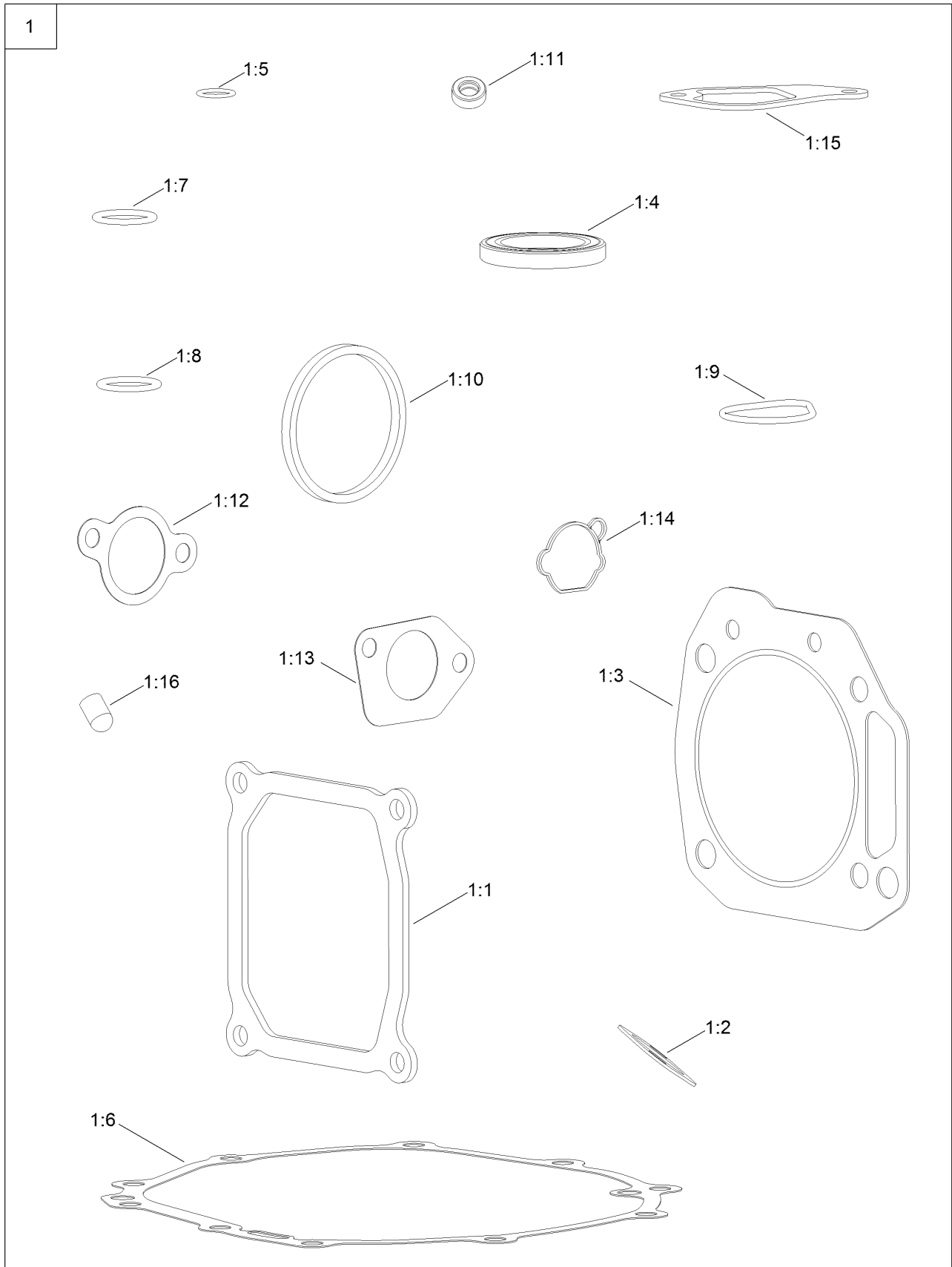

Gasket and Seal Kit

Engine Assembly No. 121-0412 (continued)

<i>Ref.</i>	<i>Part Number</i>	<i>Qty.</i>	<i>Description</i>	<i>Ref.</i>	<i>Part Number</i>	<i>Qty.</i>	<i>Description</i>
1	127-9192	1	Gasket And Seal Kit	1:9	120-4343	1	Seal-Pump, Oil
1:1	120-4206	1	Gasket-Cover, Valve	1:10	120-4362	1	Seal-Adaptor, Oil
1:2	120-4317	1	Gasket-Exhaust	1:11	120-4257	1	Seal-Oil
1:3	120-4201	1	Gasket-Cylinder	1:12	120-4250	1	Gasket-Carburetor
1:4	120-4267	2	Seal-Oil	1:13	120-4247	2	Gasket-Carburetor
1:5	120-4262	1	O-Ring	1:14	127-9185	1	Gasket-Carburetor
1:6	120-4260	1	Gasket-Crankcase	1:15	120-4264	1	Gasket-Breather
1:7	120-4348	1	O-Ring	1:16	127-9189	1	Cap-Seal
1:8	120-4282	1	O-Ring				

Fuel Delivery Assembly

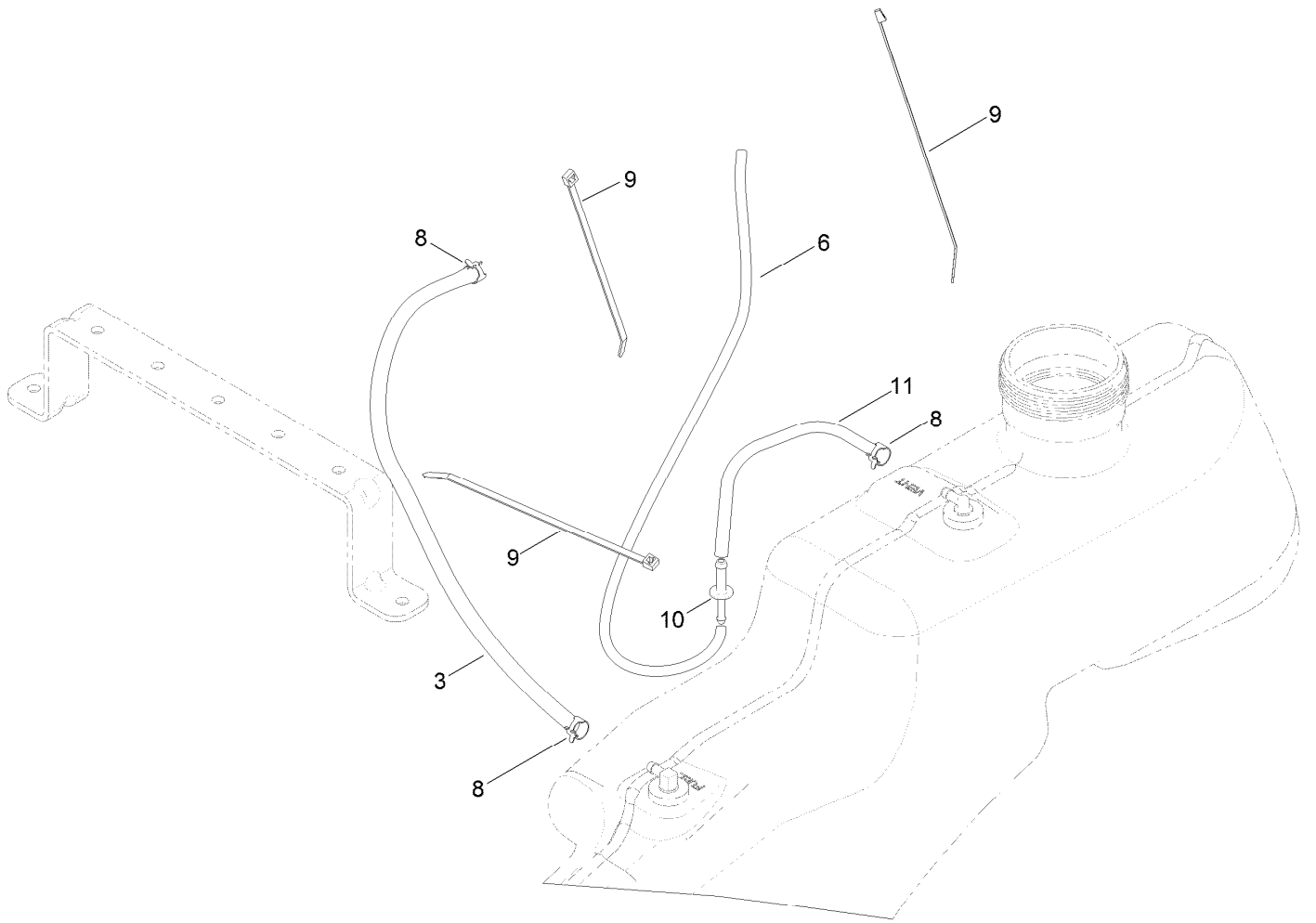

Fuel Delivery Assembly (continued)

<i>Ref.</i>	<i>Part Number</i>	<i>Qty.</i>	<i>Description</i>	<i>Ref.</i>	<i>Part Number</i>	<i>Qty.</i>	<i>Description</i>
3	109-0307	1	Hose-Fuel	9	614249	3	Tie-Cable
6	110-3254	1	Hose-Fuel	10	117-5399	1	Adaptor-Orifice
8	2412-98	3	Clamp-Hose	11	110-1876	1	Hose-Fuel

Body Styling and Fuel Tank Assembly

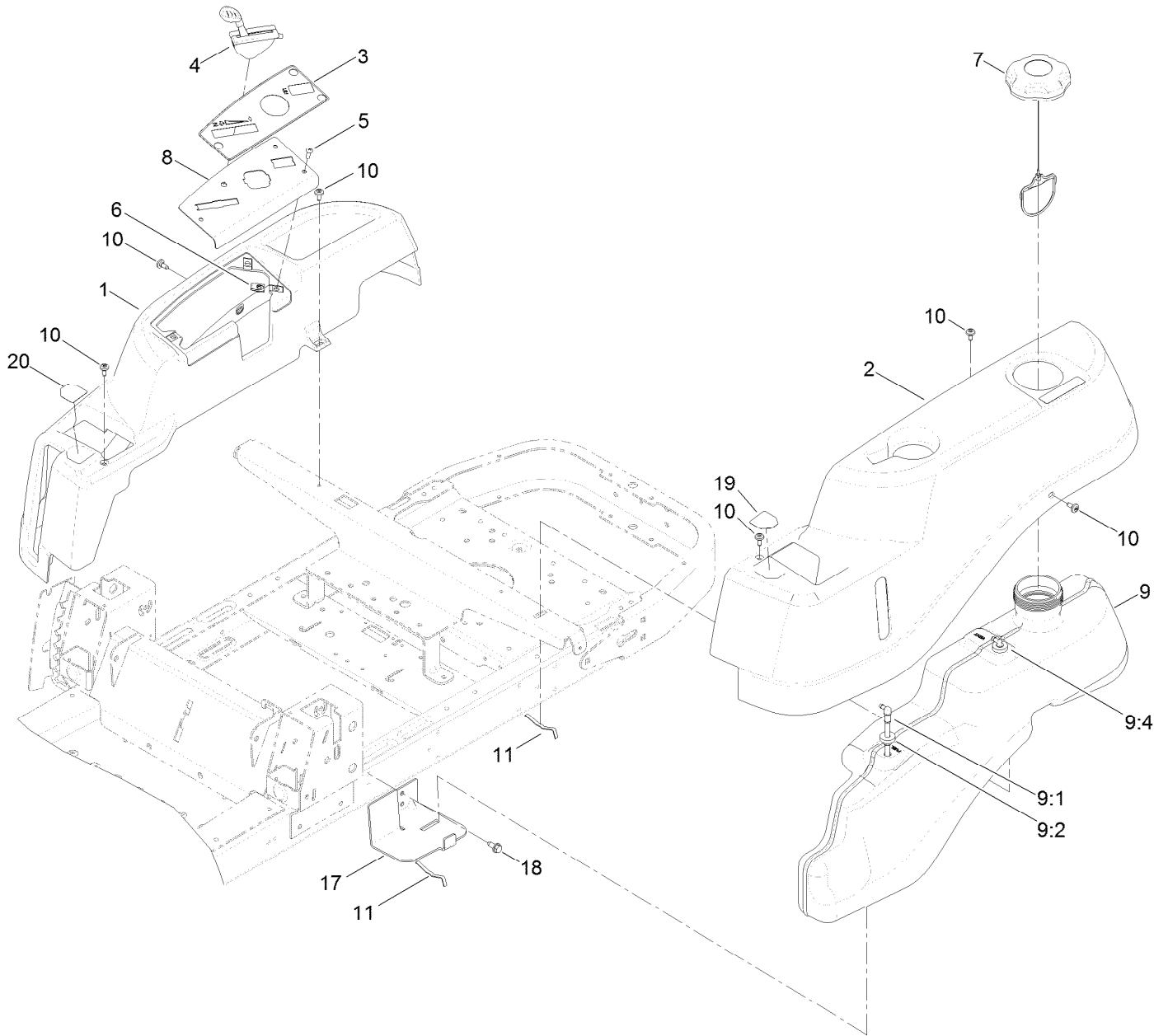

Body Styling and Fuel Tank Assembly (continued)

<i>Ref.</i>	<i>Part Number</i>	<i>Qty.</i>	<i>Description</i>	<i>Ref.</i>	<i>Part Number</i>	<i>Qty.</i>	<i>Description</i>
1	119-3335	1	Pod-RH	9:1	121-0793	1	Connector-Elbow, 90 DEG
2	119-3334	1	Pod-LH	9:2	46-6560	2	Bushing
3	121-0771	1	Decal-Panel, Control	9:4	117-7400	1	Fitting-Plastic
4	121-0767	1	Cable-Throttle And Choke	10	120-7950	6	Screw-Shoulder
5	3258-166	3	Screw-PRH	11	609830	2	Spring
6	107069	3	Clip	17	119-3476-03	1	Support-Tank, Front
7	120-5461	1	Cap-Fuel, Ratcheting	18	32144-70	2	Screw-HWHTF
8	119-3378-03	1	Plate-Control	19	119-8814	1	Decal-Control Lever, LH
9	119-3324	1	Fuel Tank ASM	20	119-8815	1	Decal-Control Lever, RH

Battery and Electrical Assembly

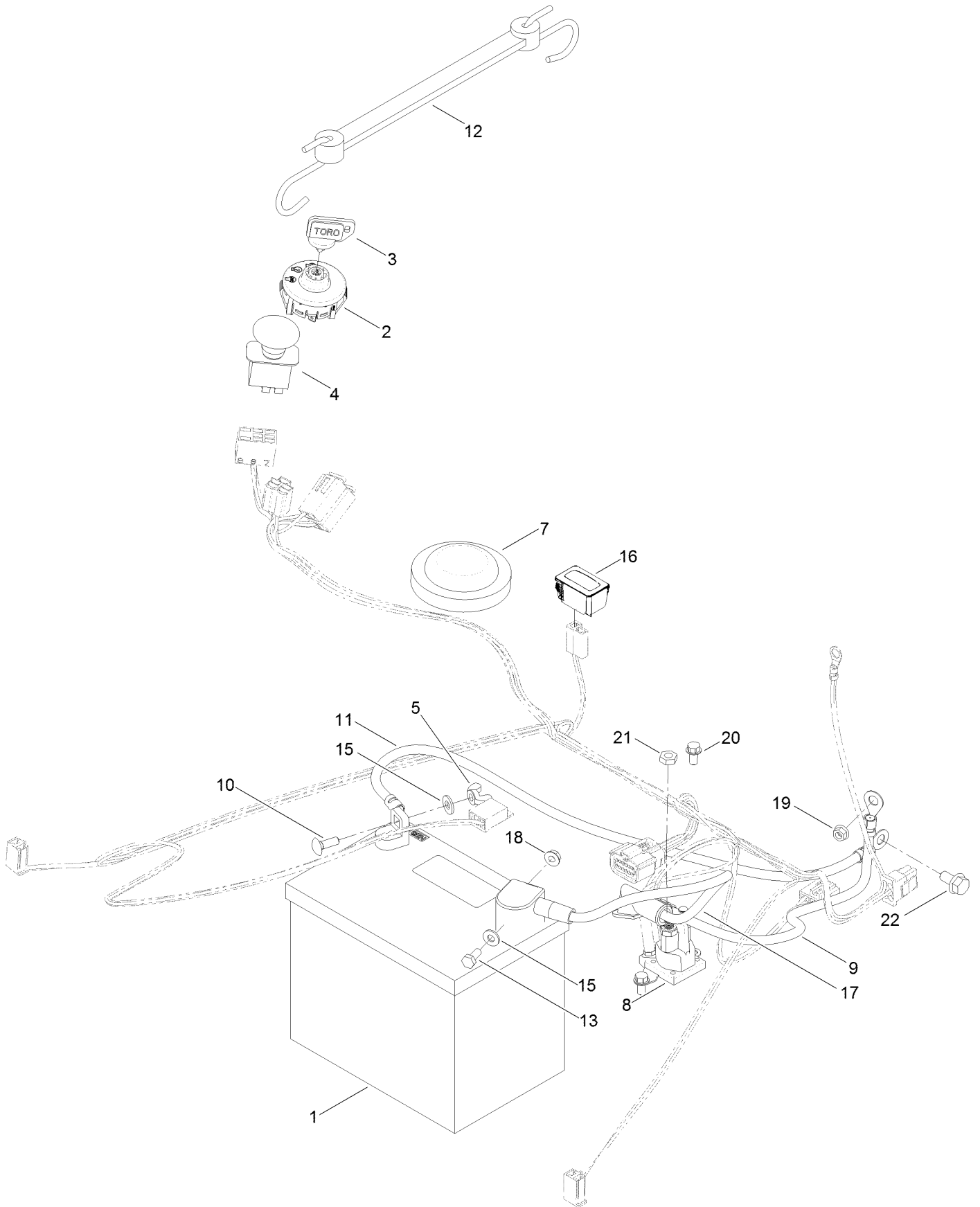

Battery and Electrical Assembly (continued)

<i>Ref.</i>	<i>Part Number</i>	<i>Qty.</i>	<i>Description</i>	<i>Ref.</i>	<i>Part Number</i>	<i>Qty.</i>	<i>Description</i>
1	105-1692	1	Battery-Dry	12	104-2466	1	Holddown-Battery
2	117-2221	1	Switch-Ignition	13	321-3	1	Screw-HH
3	63-8360	1	Key-Ignition	15	3256-22	2	Washer-Flat
4	103-5221	1	Switch-PTO	16	120-2244	1	Hourmeter
5	32103-22	1	Nut-Wing	17	119-8897	1	Cable-Battery, Red
7	100-3524	1	Switch-Seat	18	32128-33	1	Nut-HF
8	117-1197	1	Solenoid	19	33003-00	1	Nut-HF
9	121-0711	1	Cable-Battery, Positive	20	32144-4	2	Screw-HWH
10	3229-1	1	Bolt-CARR	21	3220-2	2	Nut-Jam
11	119-8899	1	Cable-Battery, Black	22	3234-14	1	Screw-HHF

Fuse and Wire Harness Assembly

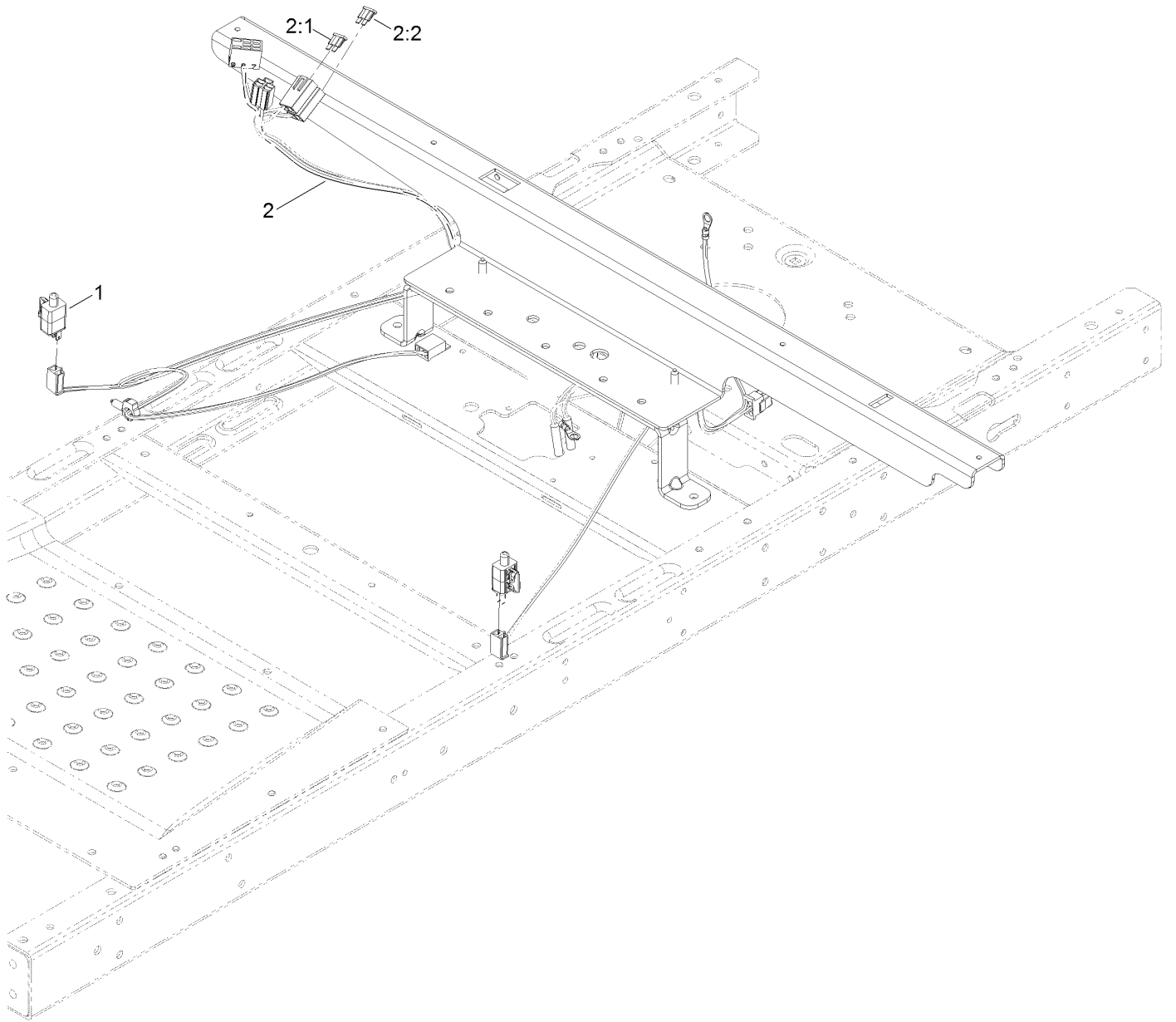

Fuse and Wire Harness Assembly (continued)

<i>Ref.</i>	<i>Part Number</i>	<i>Qty.</i>	<i>Description</i>
1	110-6765	2	Switch
2	130-7013	1	Harness-Wire

<i>Ref.</i>	<i>Part Number</i>	<i>Qty.</i>	<i>Description</i>
2:1	109103	1	Fuse-Blade, 30 Amp
2:2	109102	1	Fuse-Blade, 25 Amp

32 Inch Deck Assembly

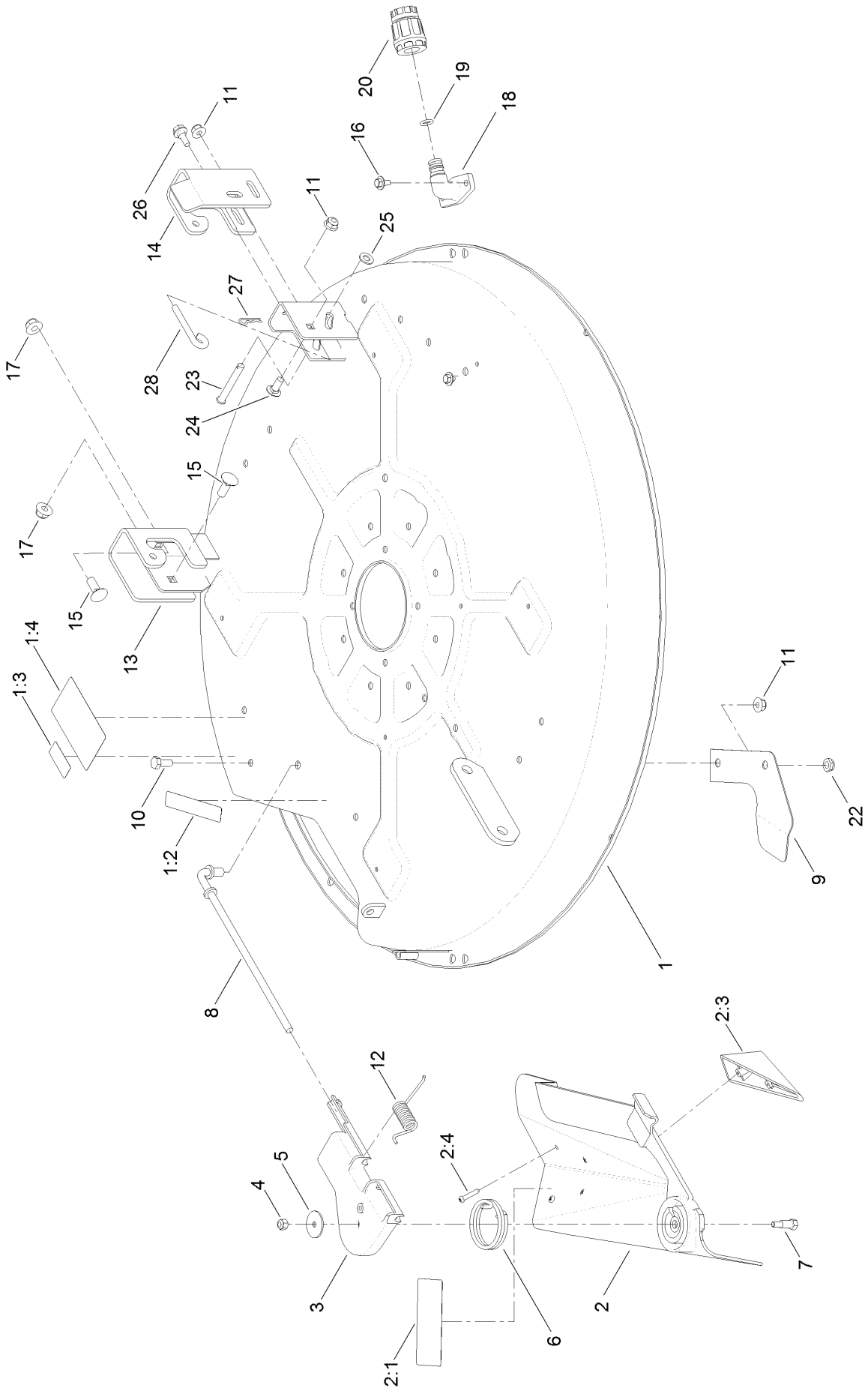

32 Inch Deck Assembly (continued)

<i>Ref.</i>	<i>Part Number</i>	<i>Qty.</i>	<i>Description</i>	<i>Ref.</i>	<i>Part Number</i>	<i>Qty.</i>	<i>Description</i>
1	131-3602	1	32 Inch Deck And Decal ASM	11	104-8300	3	Nut-Flange, NI
1:2	93-7009	1	Decal-Danger	12	92-2493	1	Spring-Torsion
1:3	114-1606	2	Decal-Danger	13	131-4138	1	Bracket-Hanger, RH
1:4	110-6691	2	Decal-Danger	14	131-1091	1	Bracket-Hanger, LH
2	120-2298	1	32 Inch Deflector ASM	15	3231-2	2	Bolt-CARR
2:1	110-6691	1	Decal-Danger	16	46-8560	2	Screw-HHFTF
2:3	93-7696	2	Kicker	17	104-8301	2	Nut-Flange, NI
2:4	93-0231	4	Screw-PPH	18	95-2747	1	Fitting-Washout
3	88-4540	1	Pivot-Hinge, Deflector	19	46-6290	1	O-Ring
4	3296-42	1	Nut-Lock, NI	20	95-3270	1	Connector-Hose
5	3256-55	1	Washer-Flat	22	3296-59	1	Nut-Lock, NI
6	88-6160	1	Spring-Torsion	23	110-0618	1	Pin-Clevis
7	92-8916	1	Bolt-Shoulder	24	3230-23	1	Screw-CARR
8	119-8858	1	Rod-Pivot	25	3256-23	1	Washer-Flat
9	119-8877-03	1	Ramp-Deflector	26	120-7024	1	Screw-Shoulder, HHF
10	322-3	1	Screw-HH	27	1-806003	1	Pin-Cotter
				28	131-0955	1	Rod-Deck Level

32 Inch Deck, Belt and Blade Assembly

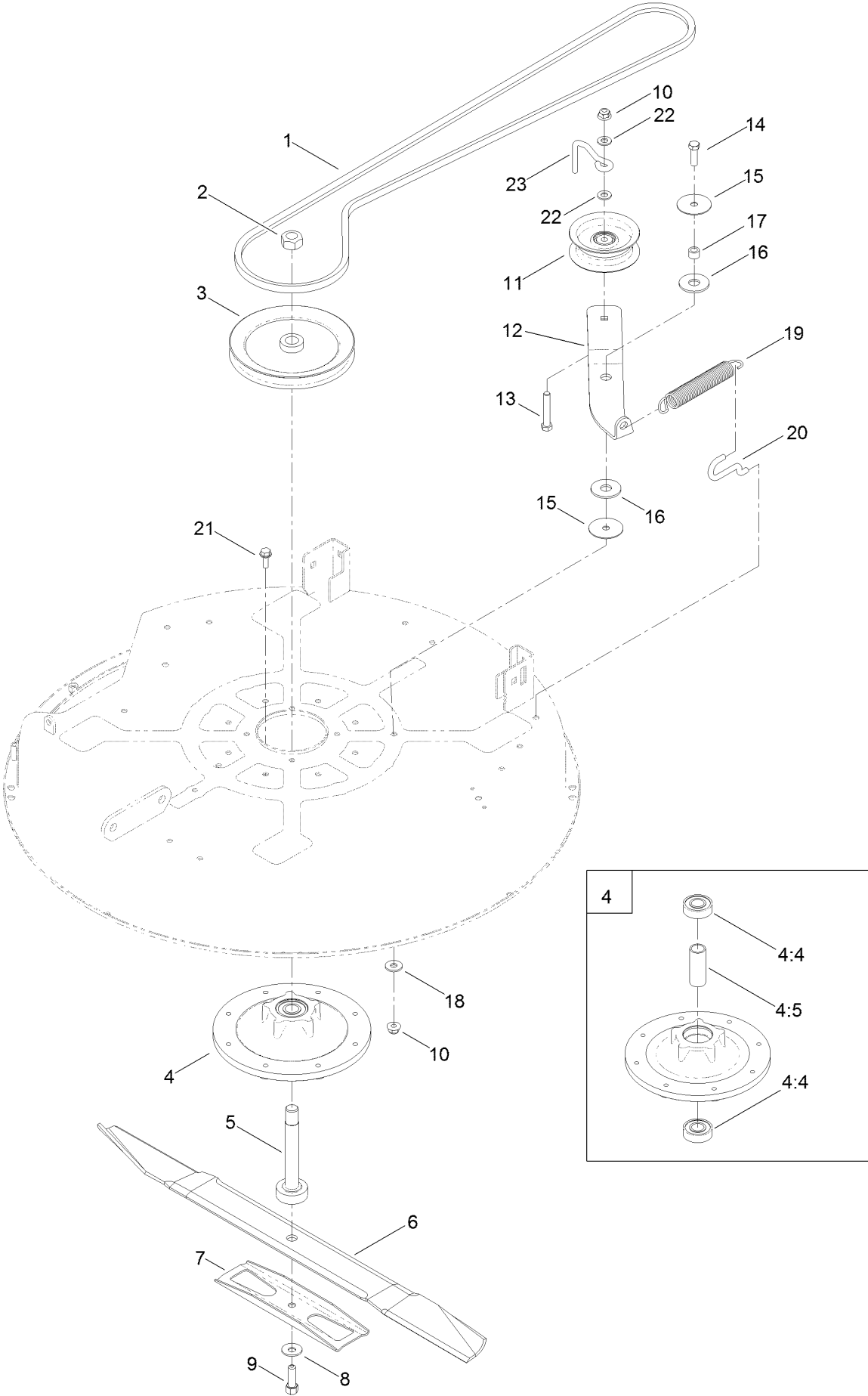

32 Inch Deck, Belt and Blade Assembly (continued)

<i>Ref.</i>	<i>Part Number</i>	<i>Qty.</i>	<i>Description</i>	<i>Ref.</i>	<i>Part Number</i>	<i>Qty.</i>	<i>Description</i>
1	119-8821	1	V-Belt, 81.8 Inch	12	119-8966	1	Arm-Idler
2	3219-7	1	Nut-Hex	13	323-11	1	Screw-HH
3	119-8804	1	Pulley-Deck	14	323-7	1	Screw-HH
4	119-0368	1	Spindle Housing ASM	15	120-2229	2	Washer
4:4	251-297	2	Bearing-Ball	16	114-0463	2	Washer-Friction, Composite
4:5	83-7020	1	Spacer-Bearing	17	115-4986	1	Spacer
5	119-8825	1	Shaft-Spindle	18	80-6990	1	Washer-Hardened
6	80-4430-03	1	Blade-Recycler, 31.35 Inch	19	106-2177	1	Spring-Extension
7	80-4570-03	1	Stiffener	20	88-5970	1	Hook-Return, Spring
8	3290-465	1	Washer-Belleville	21	32144-41	8	Screw-Taptite
9	26-0671	1	Screw-HH	22	3256-24	2	Washer-Flat
10	104-8301	2	Nut-Flange, NI	23	107-7307	1	Guide-Idler, Belt
11	106-2175	1	Pulley-Idler, Flat				

Attachments and Accessories

For 74710 TimeCutter SS 3225 Riding Mower

Product Name	Model/Part
Armrest Kit	105-6978
Oil-Synthetic, All Season	117-0066
Fuel Stabilizer (4oz).....	117-0089
Fuel Stabilizer (16oz).....	117-0090
Seat Cover W/o Arm Rest - TC 18in	117-0096
Jack Mount Kit	126-5251
Jack Kit	127-6666
Attachment Mount Kit	131-3966
Weight Kit	131-7658
Deluxe Seat Kit.....	131-7699
10w30 4-cycle Engine Oil (32oz Bottle)	38280
Toro 4-cycle Sae 30 Oil (32oz Bottle).....	38903
Storage Cover	490-7516
Foot Assist Deck Lift Kit, 2011 and After Zero-Turn-Radius Riding Mower	79010
Sunshade Kit	79011
32in Recycler Kit, 2011 and After TimeCutter Z Riding Mower	79017
Cargo Carrier.....	79040
Assist Handle and Step Kit	79339
32in Bagger	79387

Notes:

Notes:

Notes:



Count on it.