



Count on it.

Operator's Manual

**Z Master[®] Professional 6000
Series Riding Mower**

**with 132cm or 152cm TURBO FORCE[®] Side
Discharge Mower**

Model No. 74919TE—Serial No. 315000001 and Up

Model No. 74925TE—Serial No. 315000001 and Up



g027403



This product complies with all relevant European directives; for details, please see the separate product-specific Declaration of Conformity (DOC) sheet.

This spark ignition system complies with Canadian ICES-002

⚠ WARNING

**CALIFORNIA
Proposition 65 Warning**

This product contains a chemical or chemicals known to the State of California to cause cancer, birth defects, or reproductive harm.

The engine exhaust from this product contains chemicals known to the State of California to cause cancer, birth defects, or other reproductive harm.

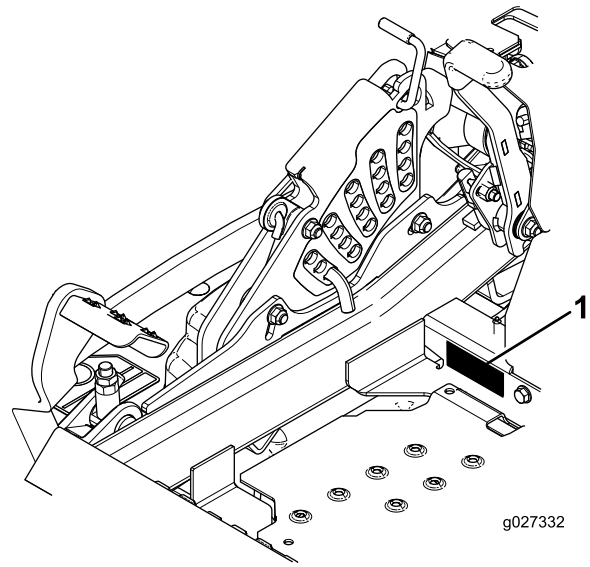

Figure 1

1. Model and serial number location

Model No. _____
Serial No. _____

⚠ WARNING

Removing standard original equipment parts and accessories may alter the warranty, traction, and safety of the machine. Failure to use original Toro parts could cause serious injury or death. Making unauthorized changes to the engine, fuel or venting system, may violate EPA and CARB regulations.

Replace all parts including, but not limited to, tires, belts, blades, and fuel system components with original Toro parts.

Introduction

This rotary-blade, riding lawn mower is intended to be used by residential homeowners or professional, hired operators. It is designed primarily for cutting grass on well-maintained lawns on residential or commercial properties. It is not designed for cutting brush or for agricultural uses.

Read this information carefully to learn how to operate and maintain your product properly and to avoid injury and product damage. You are responsible for operating the product properly and safely.

You may contact Toro directly at www.Toro.com for product safety and operation training materials, accessory information, help finding a dealer, or to register your product.

Whenever you need service, genuine Toro parts, or additional information, contact an Authorized Service Dealer or Toro Customer Service and have the model and serial numbers of your product ready. [Figure 1](#) identifies the location of the model and serial numbers on the product. Write the numbers in the space provided.

This manual identifies potential hazards and has safety messages identified by the safety alert symbol ([Figure 2](#)), which signals a hazard that may cause serious injury or death if you do not follow the recommended precautions.



Figure 2

1. Safety alert symbol

This manual uses 2 words to highlight information. **Important** calls attention to special mechanical information and **Note** emphasizes general information worthy of special attention.

Contents

Safety	4	Replacing the Fuel Filter	43
Safe Operating Practices	4	Servicing the Fuel Tank	43
Toro Riding Mower Safety	6	Electrical System Maintenance	44
Sound Pressure	7	Servicing the Battery	44
Sound Power	7	Servicing the Fuses	45
Vibration Level for Model 74919TE	7	Drive System Maintenance	46
Vibration Level for Model 74925TE	7	Checking the Seat Belt	46
Slope Indicator	8	Checking the Rollover Protection System (ROPS)	
Safety and Instructional Decals	9	Knobs	46
Product Overview	15	Adjusting the Tracking	46
Controls	15	Checking the Tire Pressure	47
Specifications	16	Checking the Wheel Lug Nuts	47
Operation	17	Checking the Wheel Hub Slotted Nut	47
Adding Fuel	17	Adjusting the Caster Pivot Bearing	47
Checking the Engine-Oil Level	18	Cooling System Maintenance	48
Breaking in a New Machine	18	Cleaning the Engine Screen and the Engine-Oil	
Using the Rollover Protection System (ROPS)	18	Cooler	48
Think Safety First	19	Cleaning the Engine Cooling Fins and	
Operating the Parking Brake	20	Shrouds	48
Operating the Mower-Blade-Control Switch		Checking and Cleaning the Hydraulic-Unit	
(PTO)	20	Shrouds	49
Operating the Throttle	21	Brake Maintenance	50
Operating the Choke	21	Adjusting the Parking Brake	50
Operating the Ignition Switch	21	Belt Maintenance	51
Using the Fuel-Shutoff Valve	21	Inspecting the Belts	51
Starting and Stopping the Engine	22	Replacing the Mower Belt	51
The Safety-Interlock System	23	Replacing the Hydraulic-Pump Drive Belt	52
Driving Forward or Backward	24	Controls System Maintenance	53
Stopping the Machine	25	Adjusting the Control Handle Position	53
Adjusting the Height of Cut	25	Adjusting the Motion-Control Linkage	53
Adjusting the Anti-Scalp Rollers	26	Adjusting the Motion-Control Damper	54
Adjusting the Flow-Baffle-Cam Locks	27	Adjusting the Motion-Control Neutral-Lock	
Positioning the Flow Baffle	27	Pivot	54
Positioning the Seat	28	Hydraulic System Maintenance	55
Changing the Seat Suspension	28	Servicing the Hydraulic System	55
Using the Drive-Wheel Release Valves	28	Mower Deck Maintenance	57
Using the Side Discharge	29	Leveling the Mower Deck	57
Transporting the Machine	29	Servicing the Cutting Blades	59
Loading the Machine	30	Removing the Mower Deck	62
Using the Z Stand®	31	Replacing the Grass Deflector	63
Operating Tips	32	Cleaning	64
Maintenance	34	Cleaning under the Mower	64
Recommended Maintenance Schedule(s)	34	Disposing of Waste	64
Pre-maintenance Procedures	35	Storage	64
Releasing the Mower-Deck Curtain	35	Cleaning and Storage	64
Removing the Sheet-Metal Guard	35	Troubleshooting	66
Lubrication	36	Schematics	68
Lubricating the Machine	36		
Greasing the Mower	36		
Lubricating the Caster Wheel Hubs	37		
Engine Maintenance	38		
Servicing the Air Cleaner	38		
Servicing the Engine Oil	39		
Servicing the Spark Plugs	41		
Checking the Spark Arrester (if equipped)	42		
Fuel System Maintenance	43		

Safety

This machine has been designed in accordance with EN ISO 5395:2013.

Improperly using or maintaining the machine can result in injury. To reduce the potential for injury, comply with these safety instructions and always pay attention to the safety alert symbol, which means *Caution, Warning, or Danger*—personal safety instruction. Failure to comply with the instruction may result in personal injury or death.

Safe Operating Practices

This product is capable of amputating hands and feet and throwing objects. Always follow all safety instructions to avoid serious injury or death.

Training

- Read the *Operator's Manual* and other training material. If the operator(s) or mechanic(s) cannot read or understand the information it is the owner's responsibility to explain this material to them.
- Become familiar with the controls and the proper use of the equipment.
- Never allow children or people unfamiliar with these instructions to use the lawnmower. Local regulations can restrict the age of the operator.
- Never mow while people, especially children, or pets are nearby.
- Keep in mind that the operator or user is responsible for accidents or hazards occurring to other people or their property.
- Do not carry passengers.
- All drivers should seek and obtain professional and practical instruction. Such instruction should emphasize:
 - the need for care and concentration when working with ride-on machines;
 - control of a ride-on machine sliding on a slope will not be regained by the application of the control levers. The main reasons for loss of control are:
 - ◇ insufficient wheel grip, especially on wet grass;
 - ◇ being driven too fast;
 - ◇ inadequate braking;
 - ◇ the type of machine is unsuitable for its task;
 - ◇ lack of awareness of the effect of ground conditions, especially slopes;
 - ◇ incorrect hitching and load distribution.

Preparation

- Thoroughly inspect the area where the equipment is to be used and remove all objects which may be thrown by the machine.

- Replace worn or damaged silencers.
- Before using, always visually inspect to see that the blades, blade bolts, and cutter assembly are not worn or damaged. Replace worn or damaged blades and bolts in sets to preserve balance.
- On multi-bladed machines, take care as rotating one blade can cause other blades to rotate.

Operation

- Lightning can cause severe injury or death. If lightning is seen or thunder is heard in the area, do not operate the machine; seek shelter.
- Be alert, slow down and use caution when making turns. Look behind and to the side before changing directions.
- Do not operate the engine in a confined space where dangerous carbon monoxide fumes can collect.
- Mow only in daylight or in good artificial light.
- While mowing, always wear substantial, slip-resistant footwear and long trousers. Do not operate the equipment when barefoot or wearing open sandals.
- Before attempting to start the engine, disengage all blade attachment clutches and shift into neutral.
- Do not use on slopes greater than 15 degrees.
- Remember that there is no such thing as a safe slope. Travel on grass slopes requires particular care. To guard against overturning:
 - Do not stop or start suddenly when on a slope;
 - Use slow speeds on slopes and during tight turns;
 - Stay alert for humps and hollows and other hidden hazards;
- Use care when pulling loads or using heavy equipment.
 - Use only approved drawbar hitch points.
 - Limit loads to those you can safely control.
 - Do not turn sharply. Use care when reversing.
- Watch out for traffic when crossing or near roadways.
- Stop the blades rotating before crossing surfaces other than grass.
- When using any attachments, never direct discharge of material toward bystanders nor allow anyone near the machine while in operation.
- Never operate the machine with damaged guards or without safety protective devices in place.
- Do not change the engine governor settings or overspeed the engine. Operating the engine at excessive speed can increase the hazard of personal injury.
- Before leaving the operator's position:
 - Disengage the power take-off and lower the attachments;
 - Change into neutral and set the parking brake;
 - Stop the engine and remove the key.

- Disengage the attachment drives, stop the engine, and disconnect the spark-plug wire(s) or remove the ignition key
 - Before clearing blockages or unclogging the chute;
 - Before checking, cleaning, or working on the machine;
 - After striking a foreign object. Inspect the machine for damage and make repairs before restarting and operating the equipment;
 - If the machine starts to vibrate abnormally (check immediately).
- Disengage drive to attachments when transporting or not in use.
- Stop the engine and disengage the attachment drives
 - Before fuelling;
 - Before removing the grass catcher;
 - Before making height adjustment unless adjustment can be made from the operator's position.
- Reduce the throttle setting during engine run-out and, if the engine is provided with a shutoff valve, turn the fuel off at the conclusion of mowing.

Rollover Protection System (ROPS)—Use and Maintenance

- The ROPS is an integral and effective safety device. Keep a folding ROPS in the raised and locked position and use the seat belt when operating the machine.
- Lower a folding ROPS temporarily only when absolutely necessary. Do not wear the seat belt when folded down.
- Be aware there is no rollover protection when a folded ROPS is in the down position.
- Be certain that the seat belt can be released quickly in the event of an emergency.
- Check the area to be mowed and never fold down a folding ROPS in areas where there are slopes, drop offs or water.
- Check carefully for overhead clearances (i.e. branches, doorways, electrical wires) before driving under any objects and do not contact them.
- Keep the ROPS in safe operating condition by periodically thoroughly inspecting for damage and keeping all mounting fasteners tight.
- Replace a damaged ROPS. Do not repair or revise.
- **Do not** remove the ROPS.
- Any alterations to a ROPS must be approved by the manufacturer.

Safe Handling of Fuels

- To avoid personal injury or property damage, use extreme care in handling gasoline. Gasoline is extremely flammable and the vapors are explosive.
- Extinguish all cigarettes, cigars, pipes, and other sources of ignition.
- Use only an approved fuel container.
- Never remove fuel cap or add fuel with the engine running.
- Allow engine to cool before refueling.
- Never refuel the machine indoors.
- Never store the machine or fuel container where there is an open flame, spark, or pilot light such as on a water heater or on other appliances.
- Never fill containers inside a vehicle or on a truck or trailer bed with a plastic liner. Always place containers on the ground away from your vehicle before filling.
- Remove equipment from the truck or trailer and refuel it on the ground. If this is not possible, then refuel such equipment with a portable container, rather than from a fuel dispenser nozzle.
- Keep the nozzle in contact with the rim of the fuel tank or container opening at all times until fueling is complete.
- Do not use a nozzle lock open device.
- If fuel is spilled on clothing, change clothing immediately.
- Never overfill fuel tank. Replace fuel cap and tighten securely.

Maintenance and Storage

- Keep all nuts, bolts, and screws tight to be sure that the equipment is in safe working condition.
- Never store the equipment with fuel in the tank inside a building where fumes can reach an open flame or spark.
- Allow the engine to cool before storing the machine in any enclosure.
- To reduce the fire hazard, keep the engine, silencer, battery compartment, and fuel-storage area free of grass, leaves, or excessive grease.
- Check the grass catcher frequently for wear or deterioration.
- Replace worn or damaged parts for safety.
- If the fuel tank has to be drained, this should be done outdoors.
- On multi-bladed machines, take care, as rotating one blade can cause other blades to rotate.
- When machine is to be parked, stored, or left unattended, lower the cutting means unless a positive mechanical lock is used.
- To best protect your investment and maintain optimal performance of your Toro equipment, count on Toro genuine parts. When it comes to reliability, Toro delivers replacement parts designed to the exact engineering

specifications of our equipment. For peace of mind, insist on Toro genuine parts.

Hauling

- Use care when loading or unloading the machine into a trailer or truck.
- Use full width ramps for loading machine into trailer or truck.
- Tie the machine down securely using straps, chains, cable, or ropes. Both front and rear straps should be directed down and outward from the machine.

Toro Riding Mower Safety

The following list contains safety information specific to Toro products or other safety information that you must know that is not included in the CEN standard.

- Engine exhaust contains carbon monoxide, which is an odorless, deadly poison that can kill you. Do not run engine indoors or in an enclosed area.
- Keep hands, feet, hair, and loose clothing away from attachment discharge area, underside of mower and any moving parts while engine is running.
- Do not touch equipment or attachment parts which may be hot from operation. Allow to cool before attempting to maintain, adjust, or service.
- Battery acid is poisonous and can cause burns. Avoid contact with skin, eyes, and clothing. Protect your face, eyes, and clothing when working with a battery.
- Battery gases can explode. Keep cigarettes, sparks, and flames away from the battery.
- Use only Toro-approved attachments. The warranty may be voided if you use unapproved attachments.

Slope Operation

- Do not mow slopes greater than 15 degrees.
- Do not mow near drop-offs, ditches, steep banks or water. Wheels dropping over edges can cause rollovers, which may result in serious injury, death or drowning.
- Do not mow slopes when grass is wet. Slippery conditions reduce traction and could cause sliding and loss of control.
- Do not make sudden turns or rapid speed changes.
- Use a walk behind mower and/or a hand trimmer near drop-offs, ditches, steep banks or water.
- Reduce speed and use extreme caution on slopes.
- Remove or mark obstacles such as rocks, tree limbs, etc. from the mowing area. Tall grass can hide obstacles.
- Watch for ditches, holes, rocks, dips, and rises that change the operating angle, as rough terrain could overturn the machine.

- Avoid sudden starts when mowing uphill because the mower may tip backwards.
- Be aware that loss of traction may occur going downhill. Weight transfer to the front wheels may cause drive wheels to slip and cause loss of braking and steering.
- Always avoid sudden starting or stopping on a slope. If tires lose traction, disengage the blades and proceed slowly off the slope.
- Follow the manufacturer's recommendations for wheel weights or counterweights to improve stability.
- Use extreme care with grass catchers or other attachments. These can change the stability of the machine and cause loss of control.

Sound Pressure

Model 74919TE has a sound pressure level at the operator's ear of 92 dBA, which includes an Uncertainty Value (K) of 1 dBA.

Model 74925TE has a sound pressure level at the operator's ear of 93 dBA, which includes an Uncertainty Value (K) of 1 dBA.

The sound pressure level was determined according to the procedures outlined in EN ISO 5395:2013.

Sound Power

Model 74919TE has a guaranteed sound power level of 105 dBA, which includes an Uncertainty Value (K) of 1 dBA.

Model 74925TE has a guaranteed sound power level of 105 dBA, which includes an Uncertainty Value (K) of 1 dBA.

The sound power level was determined according to the procedures outlined in ISO 11094.

Vibration Level for Model 74919TE

Hand-Arm

Measured vibration level for right hand = 1.3 m/s²

Measured vibration level for left hand = 1.5 m/s²

Uncertainty Value (K) = 0.8 m/s²

Measured values were determined according to the procedures outlined in EN ISO 5395:2013.

Whole Body

Measured vibration level = 0.32 m/s²

Uncertainty Value (K) = 0.16 m/s²

Measured values were determined according to the procedures outlined in EN ISO 5395:2013.

Vibration Level for Model 74925TE

Hand-Arm

Measured vibration level for right hand = 2.7 m/s²

Measured vibration level for left hand = 3.2 m/s²

Uncertainty Value (K) = 1.6 m/s²

Measured values were determined according to the procedures outlined in EN ISO 5395:2013.

Whole Body

Measured vibration level = 0.73 m/s²

Uncertainty Value (K) = 0.37 m/s²

Measured values were determined according to the procedures outlined in EN ISO 5395:2013.

Slope Indicator

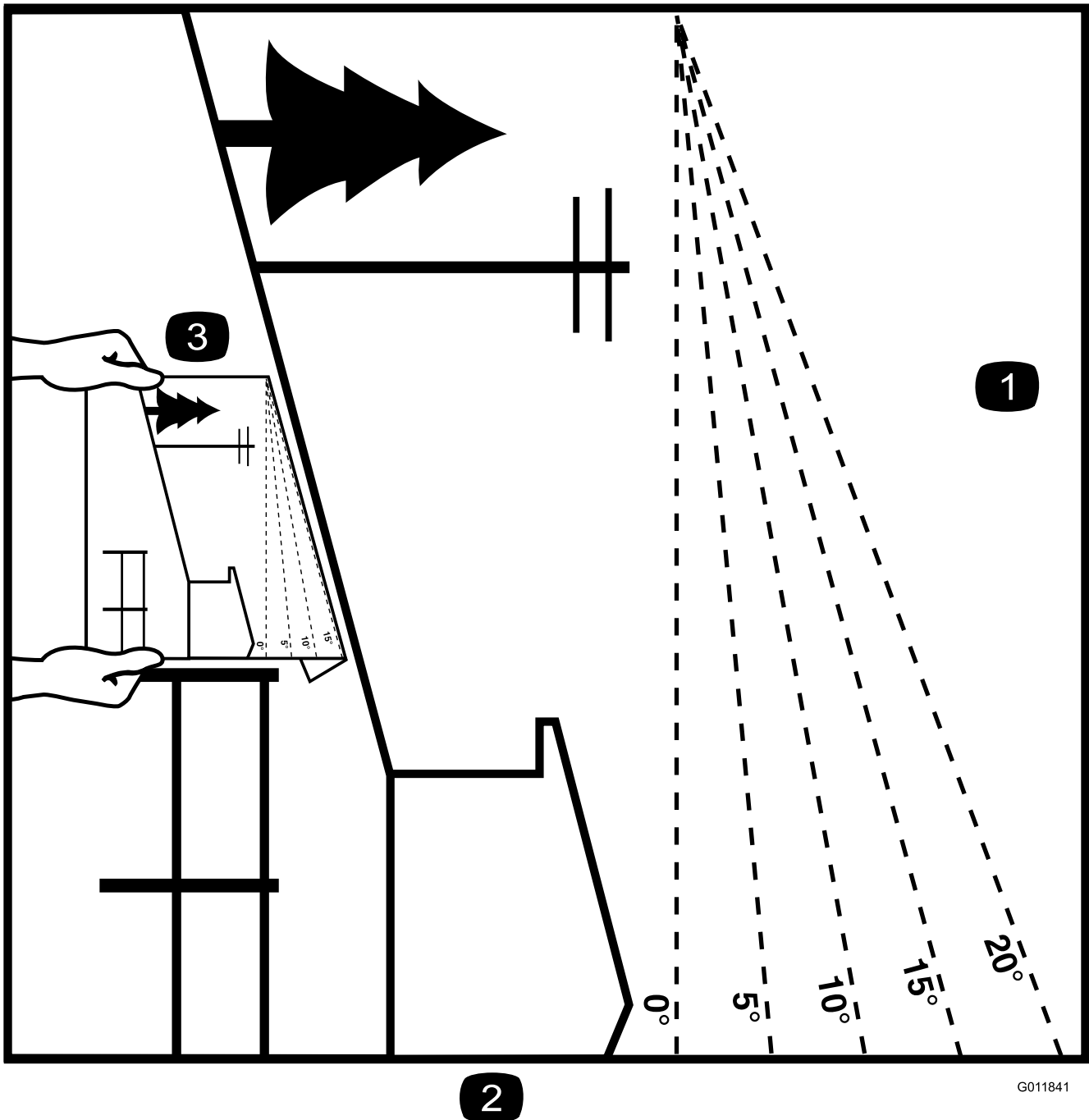

G011841

2

Figure 3

This page may be copied for personal use.

1. The maximum slope you can safely operate the machine on is **15 degrees**. Use the slope chart to determine the degree of slope of hills before operating. **Do not operate this machine on a slope greater than 15 degrees**. Fold along the appropriate line to match the recommended slope.
2. Align this edge with a vertical surface, a tree, building, fence pole, etc.
3. Example of how to compare slope with folded edge.

Safety and Instructional Decals



Safety decals and instructions are easily visible to the operator and are located near any area of potential danger. Replace any decal that is damaged or lost.



1. Grease

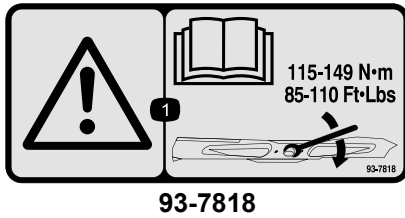

1. Warning—read the *Operator's Manual* for instructions on torquing the blade bolt/nut to 115-149 N-m (85-110 ft-lb).

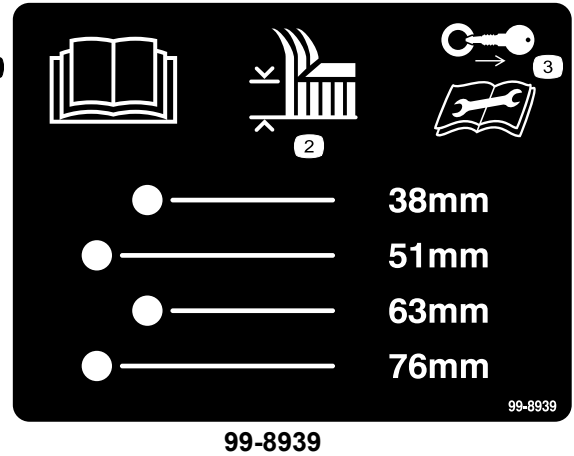

1. Read the *Operator's Manual*.
2. Height of cut
3. Remove the ignition key and read the instructions before servicing or performing maintenance.

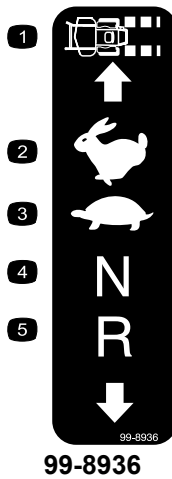

- | | |
|------------------|------------|
| 1. Machine speed | 4. Neutral |
| 2. Fast | 5. Reverse |
| 3. Slow | |



1. Warning—do not touch or approach moving belts; remove the ignition key and read the instructions before servicing or performing maintenance.



1. Warning—do not touch the hot surface.

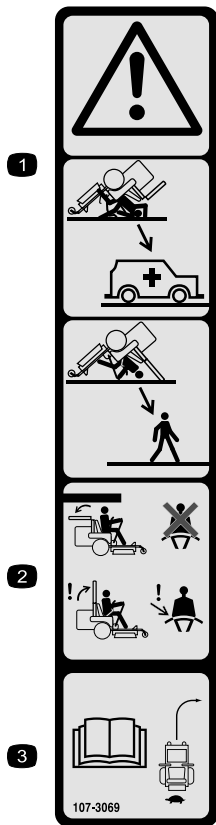

107-3069

1. Warning—there is no rollover protection when the roll bar is down.
2. To avoid injury or death from a rollover accident, keep the roll bar in the fully raised and locked position and wear the seat belt. Lower the roll bar only when absolutely necessary; do not wear the seat belt when the roll bar is down.
3. Read the *Operator's Manual*; drive slowly and carefully.

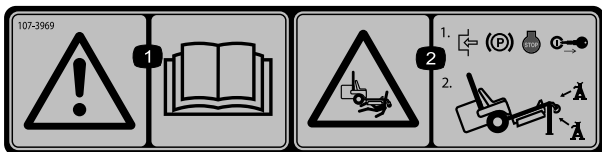

107-3969

1. Warning—read the *Operator's Manual*.
2. Crushing hazard, mower—1) Engage the parking brake, stop the engine, and remove the ignition key; 2) Properly jack the machine before working under the machine.



Manufacturer's Mark

1. Indicates the blade is identified as a part from the original machine manufacturer.

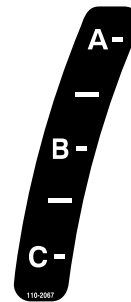

110-2067

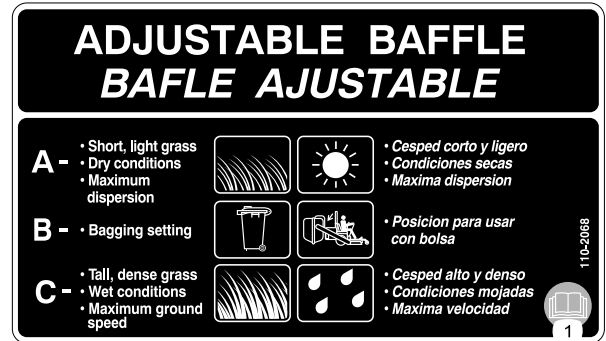

110-2068

1. Read the *Operator's Manual*.

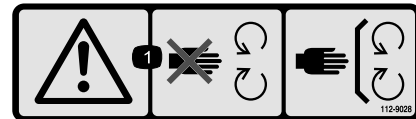

112-9028

1. Warning—stay away from moving parts; keep all guards in place.

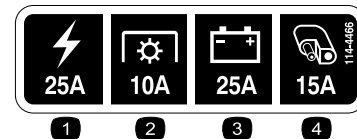

114-4466

1. Main, 25A
2. PTO, 10A
3. Charge, 25A
4. Auxiliary, 15A

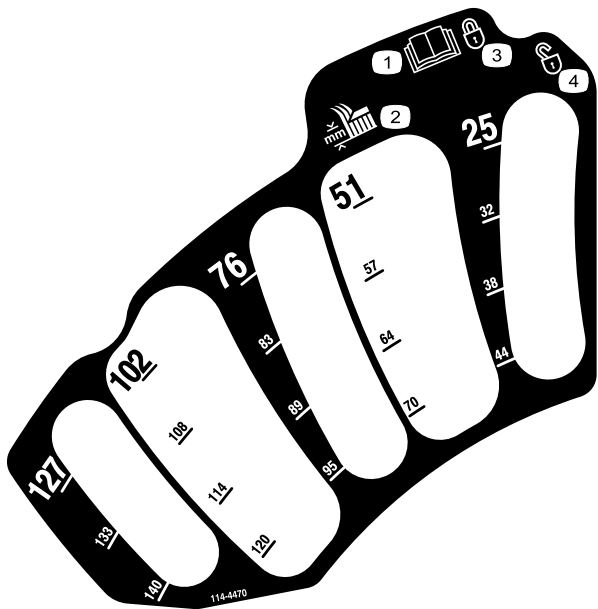

114-4470

- | | |
|--|-------------|
| 1. Read the <i>Operator's Manual</i> . | 3. Locked |
| 2. Height of cut | 4. Unlocked |

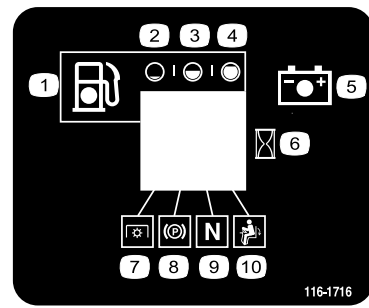

116-1716

- | | |
|------------|------------------------------|
| 1. Fuel | 6. Hour meter |
| 2. Empty | 7. PTO |
| 3. Half | 8. Parking brake |
| 4. Full | 9. Neutral |
| 5. Battery | 10. Operator presence switch |

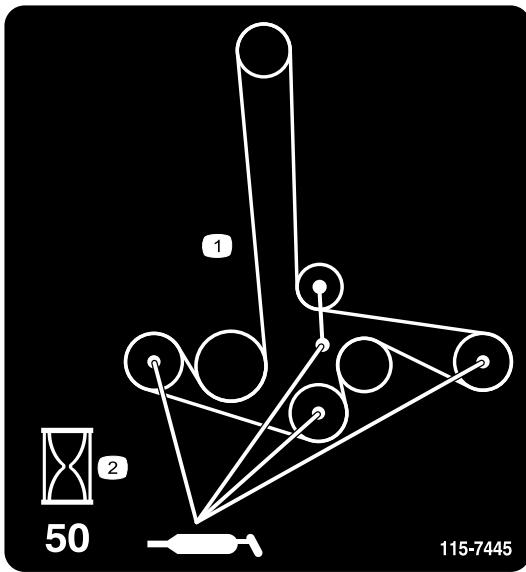

115-7445

- Grease pulleys and spindles
- Maintenance interval—50 hours

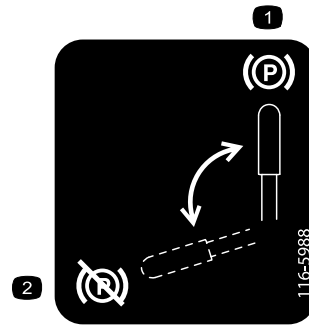

116-5988

- | | |
|--------------------------|-----------------------------|
| 1. Parking brake—engaged | 2. Parking brake—disengaged |
|--------------------------|-----------------------------|

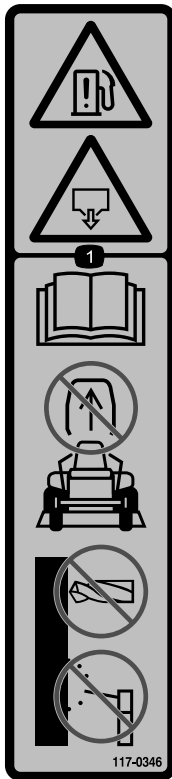

117-0346

1. Fuel leak hazard—read the *Operator's Manual*; do not attempt to remove the roll bar; do not weld, drill or modify the roll bar in any way.



117-3848

1. Thrown object hazard—keep bystanders a safe distance from the machine.
2. Thrown object hazard, mower—do not operate the without deflector, discharge cover or grass collection system in place.
3. Cutting/dismemberment of hand or foot—stay away from moving parts; keep all guards and shields in place.

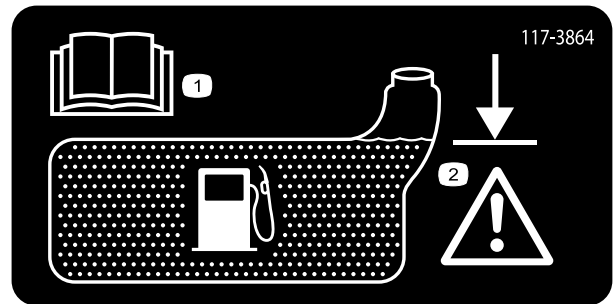

117-3864

1. Read the *Operator's Manual*.
2. Fill to bottom of filler neck; warning—do not overfill the tank.



117-3811

1. Read the *Operator's Manual*.
2. Hydraulic oil

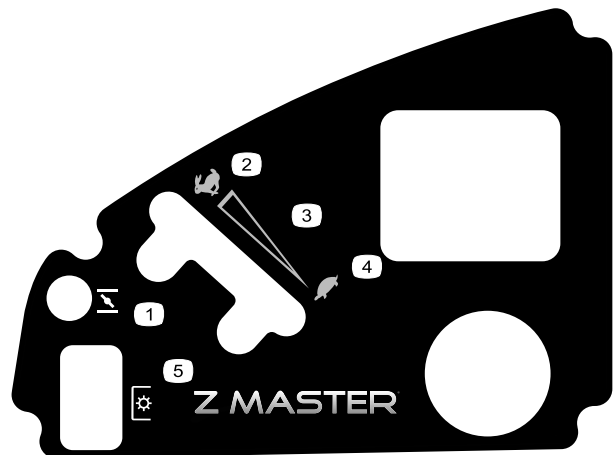

120-5897

1. Choke
2. Fast
3. Continuous variable setting
4. Slow
5. Power take-off (PTO), Blade control switch

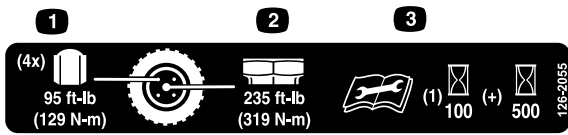

126-2055

1. Wheel lug nut torque 95 ft-lb (129 N-m) (4x)
2. Wheel hub nut torque 235 ft-lb (319 N-m)
3. Read and understand the Operator's manual before performing any maintenance, check torque after first 100 hours then every 500 hours thereafter.

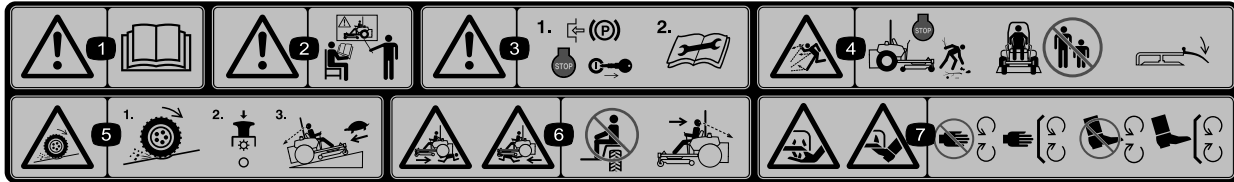

114-4468

1. Warning—read the *Operator's Manual*.
2. Warning—do not operate this machine unless you are trained.
3. Warning—engage the parking brake, stop the engine and remove the ignition key; read the instructions before servicing or performing maintenance.
4. Thrown object hazard—Stop the engine and pick up debris before operating, keep bystanders a safe distance from the machine, keep deflector in place
5. Loss of traction/control hazard, slopes—loss of traction/control on a slope, disengage the blade control switch (PTO), proceed off the slope slowly.
6. Crushing/dismemberment hazard of bystanders—do not carry passengers, look forward and down when operating the machine, look behind and down when reversing.
7. Cutting/dismemberment hazard; hand or foot—stay away from moving parts and keep all guards and shields in place.

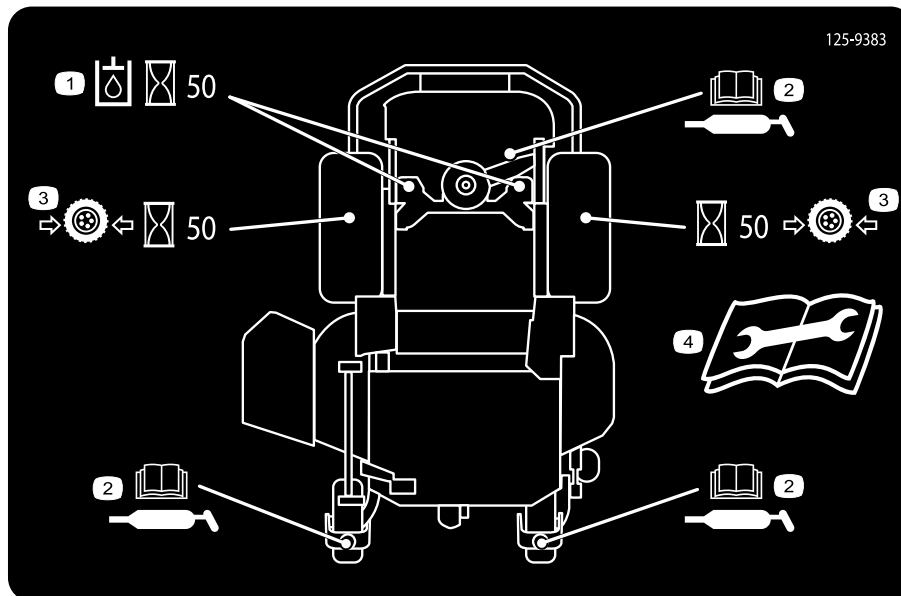

125-9383

1. Check hydraulic oil every 50 operating hours.
2. Read the *Operator's Manual* for information on lubricating the machine.
3. Check the tire pressure every 50 operating hours.
4. Read the *Operator's Manual* before servicing or performing maintenance.



Battery Symbols

Some or all of these symbols are on your battery.

- | | | |
|--|---|---|
| 1. Explosion hazard | 5. Read the <i>Operator's Manual</i> . | 9. Flush eyes immediately with water and get medical help fast. |
| 2. No fire, open flames, or smoking | 6. Keep bystanders a safe distance from the battery. | 10. Contains lead; do not discard. |
| 3. Caustic liquid/chemical burn hazard | 7. Wear eye protection; explosive gases can cause blindness and other injuries. | |
| 4. Wear eye protection | 8. Battery acid can cause blindness or severe burns. | |

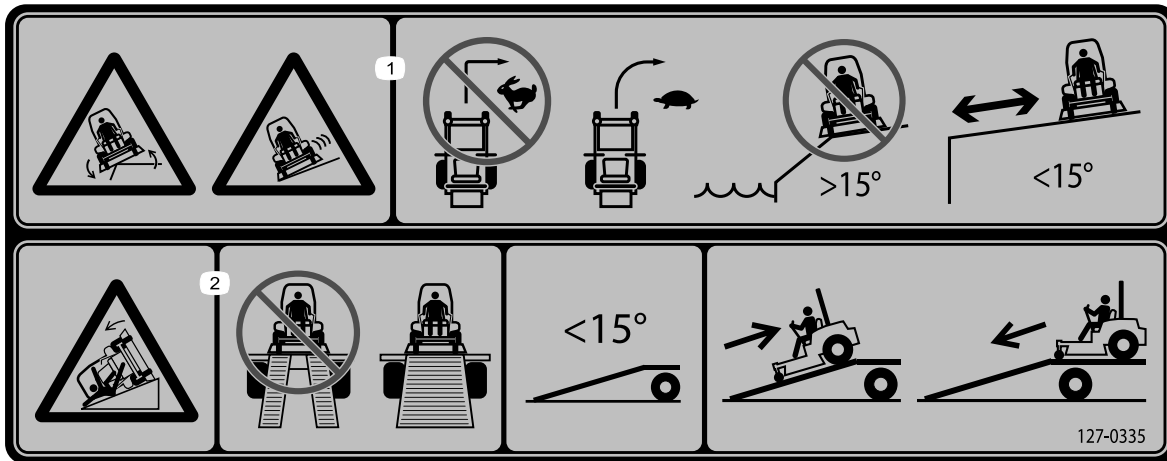

127-0335

- | | |
|--|---|
| 1. Tipping hazard on slopes—do not make sudden, tight turns; make slow, wide turns; do not use on slopes near open water; do not use this machine on slopes greater than 15 degrees. | 2. Ramp hazard—when loading onto a trailer, do not use dual ramps; only use a singular ramp wide enough for the machine and that has an incline less than 15 degrees; back up the ramp (in reverse) and drive forward off the ramp. |
|--|---|

Product Overview

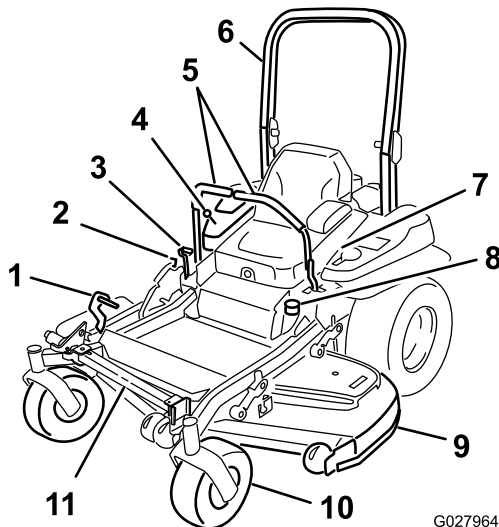

Figure 4

G027964

- | | |
|----------------------------------|------------------|
| 1. Height-of-cut deck-lift pedal | 7. Seat belt |
| 2. Transport lock | 8. Fuel cap |
| 3. Parking-brake lever | 9. Mower deck |
| 4. Controls | 10. Caster wheel |
| 5. Motion-control levers | 11. Z Stand |
| 6. Roll bar | |

Controls

Become familiar with all the controls before you start the engine and operate the machine (Figure 4 and Figure 5).

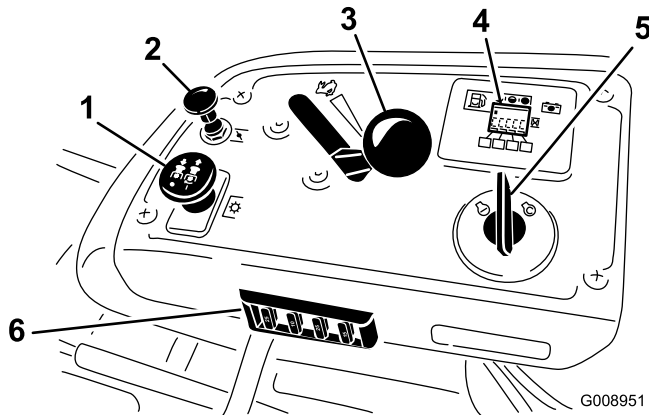

Figure 5

G008951

- | | |
|---------------------|---|
| 1. PTO Switch | 4. Hour meter/safety-interlock display/fuel gauge |
| 2. Choke | 5. Ignition switch |
| 3. Throttle control | 6. Fuses |

Hour Meter

The hour meter records the number of hours the engine has operated. It operates when the engine is running. Use these times for scheduling regular maintenance (Figure 6).

Fuel Gauge

The fuel gauge is located with the hour meter, and the bars light up when the ignition switch is on (Figure 6).

The indicator light appears when the fuel level is low—approximately 3.8 L (1 US gallon) remaining in the fuel tank.

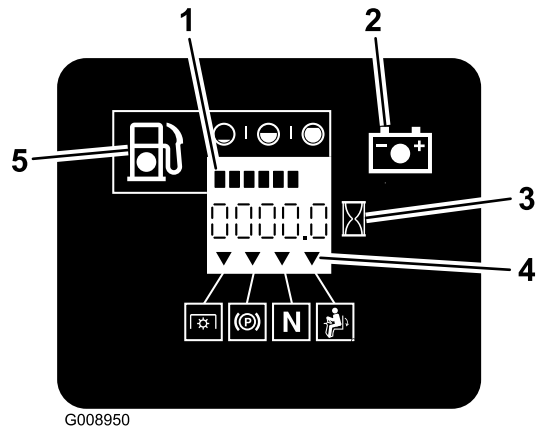

G008950

Figure 6

- | | |
|----------------------|-----------------------------|
| 1. Fuel gauge (bars) | 4. Safety-interlock symbols |
| 2. Battery light | 5. Low-fuel indicator light |
| 3. Hour meter | |

Safety-Interlock Indicators

There are symbols on the hour meter and the indicate with a black triangle that the interlock component is in the correct position (Figure 6).

Battery Indicator Light

When the ignition key is initially turned to the **Run** position for a few seconds, the battery voltage will be displayed in the area where the hours are normally displayed.

The battery light turns on when the ignition is turned on and when the charge is below the correct operating level (Figure 6).

Throttle Control

The throttle control is variable between **Fast** and **Slow**.

Choke

Use the choke to start a cold engine. Pull the choke knob up to engage it.

Blade-Control Switch (PTO)

The blade-control switch (PTO) is used to engage the electric clutch and drive the mower blades. Pull the switch up to engage the blades and release. To disengage the blades, push the blade-control switch (PTO) down or move a motion-control lever into the neutral-lock position.

Ignition Switch

This switch starts the engine and has 3 positions: **Start**, **Run**, and **Off**.

Motion-Control Levers

Use the motion-control levers to drive the machine forward, reverse, and turn either direction.

Neutral-Lock Position

The neutral-lock position is used with the safety-interlock system and to determine neutral position.

Fuel-Shutoff Valve

Close the fuel-shutoff valve (under the seat) when transporting or storing the machine.

Attachments/Accessories

A selection of Toro approved attachments and accessories is available for use with the machine to enhance and expand its capabilities. Contact your Authorized Service Dealer or Distributor or go to www.Toro.com for a list of all approved attachments and accessories.

Specifications

Note: Specifications and design are subject to change without notice.

Width:

	132 cm (52 inch) Deck	152 cm (60 inch) Deck
Cutting Width	132 cm (52 inches)	152 cm (60 inches)
Without Deck	116 cm (46 inches)	134.6 cm (53.0 inches)
Deflector—Up	146 cm (58 inches)	156.8 cm (61.7 inches)
Deflector—Down	172 cm (68 inches)	192.2 cm (75.7 inches)

Length:

	132 cm (52 inch) Deck	152 cm (60 inch) Deck
Roll Bar—Up	201 cm (79 inches)	211.1 cm (83.1 inches)
Roll Bar—Down	206 cm (81 inches)	215.4 cm (84.8 inches)

Height:

Roll Bar—Up	Roll Bar—Down
179.1 cm (70.5 inches)	118.9 cm (46.8 inches)

Weight:

Model	Weight
74919TE	537 kg (1183 lb)
74925TE	590 kg (1301 lb)

Operation

Note: Determine the left and right sides of the machine from the normal operating position.

Adding Fuel

- For best results, use only clean, fresh (less than 30 days old), unleaded gasoline with an octane rating of 87 or higher ((R+M)/2 rating method).
- **Ethanol:** Gasoline with up to 10% ethanol (gasohol) or 15% MTBE (methyl tertiary butyl ether) by volume is acceptable. Ethanol and MTBE are not the same. Gasoline with 15% ethanol (E15) by volume is not approved for use. **Never use** gasoline that contains more than 10% ethanol by volume, such as E15 (contains 15% ethanol), E20 (contains 20% ethanol), or E85 (contains up to 85% ethanol). Using unapproved gasoline may cause performance problems and/or engine damage which may not be covered under warranty.
- **Do not** use gasoline containing methanol.
- **Do not** store fuel either in the fuel tank or fuel containers over the winter unless a fuel stabilizer is used.
- **Do not** add oil to gasoline.

▲ DANGER

In certain conditions, gasoline is extremely flammable and highly explosive. A fire or explosion from gasoline can burn you and others and can damage property.

- Fill the fuel tank outdoors, in an open area, when the engine is cold. Wipe up any gasoline that spills.
- Never fill the fuel tank inside an enclosed trailer.
- Do not fill the fuel tank completely full. Add gasoline to the fuel tank until the level is 6 to 13 mm (1/4 to 1/2 inch) below the bottom of the filler neck. This empty space in the tank allows gasoline to expand.
- Never smoke when handling gasoline, and stay away from an open flame or where gasoline fumes may be ignited by a spark.
- Store gasoline in an approved container and keep it out of the reach of children. Never buy more than a 30-day supply of gasoline.
- Do not operate without the entire exhaust system in place and in proper working condition.

▲ DANGER

In certain conditions during fueling, static electricity can cause a spark which can ignite the gasoline vapors. A fire or explosion from gasoline can burn you and others and can damage property.

- Always place gasoline containers on the ground away from your vehicle before filling.
- Do not fill gasoline containers inside a vehicle or on a truck or trailer bed, because interior carpets or plastic truck-bed liners may insulate the container and slow the loss of any static charge.
- When practical, remove gas-powered equipment from the truck or trailer and fuel the equipment with the wheels on the ground.

If this is not possible, then fuel such equipment on a truck or trailer from a portable container, rather than from a gasoline-dispenser nozzle.

- If a gasoline dispenser must be used, keep the nozzle in contact with the rim of the fuel tank or container opening at all times until fueling is complete.

▲ WARNING

Gasoline is harmful or fatal if swallowed. Long-term exposure to vapors can cause serious injury and illness.

- Avoid prolonged breathing of vapors.
- Keep face away from nozzle and gas tank or conditioner bottle opening.
- Avoid contact with skin; wash off spillage with soap and water.

Using Fuel Stabilizer/Conditioner

Use a fuel stabilizer/conditioner in the machine to keep the fuel fresh during storage of 90 days or less. If you are storing the machine for longer, drain the fuel tank; refer to [Storage \(page 64\)](#).

Important: Do not use fuel additives containing methanol or ethanol.

Add the correct amount of fuel stabilizer/conditioner to the fuel, and follow the directions of the manufacturer.

Note: Fuel stabilizer/conditioner is most effective when mixed with fresh gasoline. To minimize the chance of varnish deposits in the fuel system, use fuel stabilizer at all times.

Filling the Fuel Tank

1. Park the machine on level ground.
2. Shut the engine off and set the parking brake.
3. Clean around the fuel-tank cap and remove it. Add regular unleaded gasoline to the fuel tank until the level is 6 to 13 mm (1/4 to 1/2 inch) below the bottom of the filler neck. This space in the tank allows the gasoline to expand. Do not fill the fuel tank completely full; refer to (Figure 7).

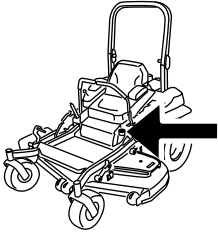

G009189

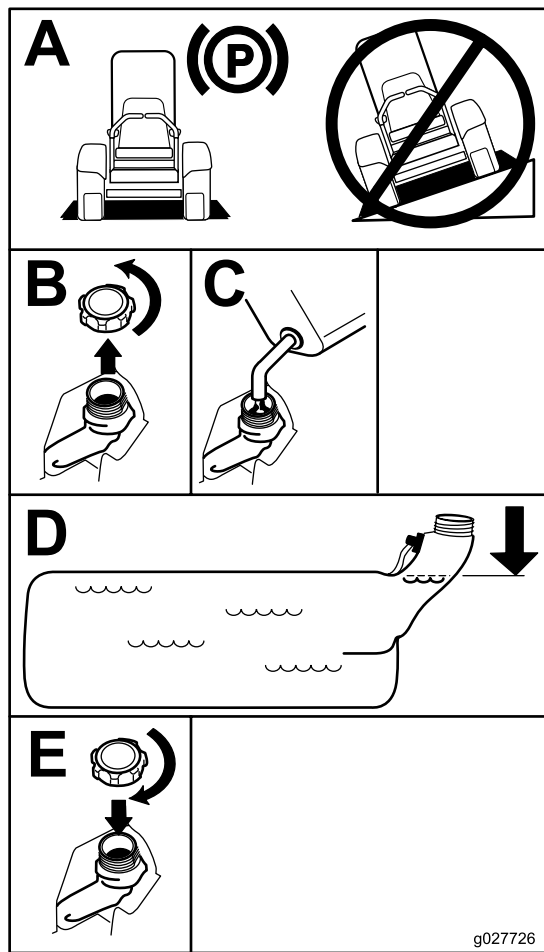

Figure 7

Breaking in a New Machine

New engines take time to develop full power. Mower decks and drive systems have a higher amount of friction when they are new, placing additional load on the engine. Allow 40 to 50 hours of break-in time for new machines to develop full power and best performance.

Using the Rollover Protection System (ROPS)

⚠ WARNING

To avoid injury or death from rollover: keep the roll bar in the fully raised locked position and use the seat belt.

Ensure that the seat is secured to the machine.

⚠ WARNING

There is no rollover protection when the roll bar is in the down position.

- Lower the roll bar only when absolutely necessary.
- Do not wear the seat belt when the roll bar is in the down position.
- Drive slowly and carefully.
- Raise the roll bar as soon as clearance permits.
- Check carefully for overhead clearances (i.e. branches, doorways, electrical wires) before driving under any objects and do not contact them.

Important: Lower the roll bar only when absolutely necessary.

Important: Ensure that the seat is secured to the machine.

1. To lower the roll bar, apply forward pressure to the upper part of the roll bar.
2. Pull both knobs out and rotate them 90° so they are not engaged (Figure 8).
3. Lower the roll bar to the down position (Figure 8).

Checking the Engine-Oil Level

Before you start the engine and use the machine, check the oil level in the engine crankcase; refer to [Checking the Engine-Oil Level](#) (page 39).

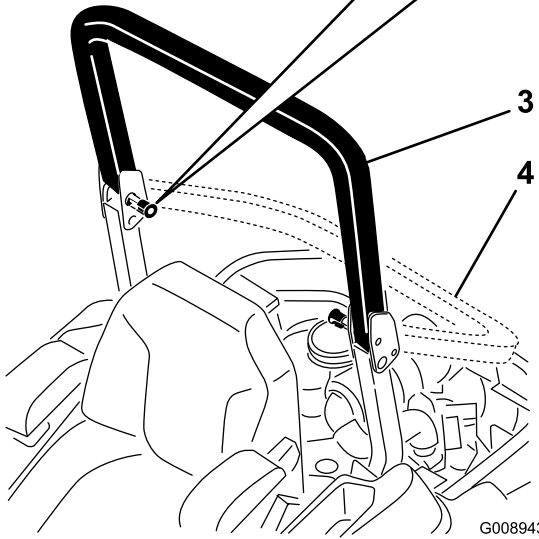
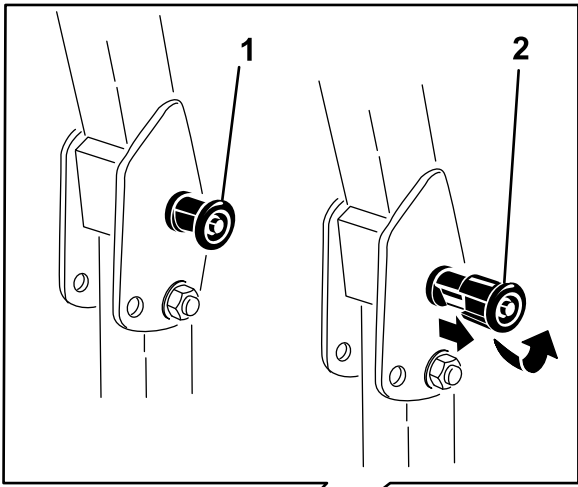

Figure 8

- | | |
|---|-------------------------------------|
| 1. ROPS knob | 3. Roll bar in the upright position |
| 2. Pull ROPS knob out and rotate 90 degrees | 4. Roll bar in the folded position |

4. To raise the roll bar, raise the roll bar to the operate position, rotate the knobs so they move partially into the grooves (Figure 8).
5. Raise the roll bar to the full upright position while pushing on the upper roll bar and the pins will snap into position when the holes align with the pins (Figure 8). Push on the roll bar and ensure that both pins are engaged.

Important: Always use the seat belt with the roll bar in the fully raised position.

Think Safety First

Please read all safety instructions and symbols in the safety section. Knowing this information could help you or bystanders avoid injury.

⚠ DANGER

Operating on wet grass or steep slopes can cause sliding and loss of control.

Wheels dropping over edges can cause rollovers, which may result in serious injury, death or drowning.

There is no rollover protection when the roll bar is down.

Always keep the roll bar in the fully raised and locked position and use the seat belt.

Read and follow the rollover protection instructions and warnings.

To avoid loss of control and possibility of rollover:

- Do not operate near drop-offs or near water.
- Do not operate on slopes greater than 15 degrees.
- Reduce speed and use extreme caution on slopes.
- Avoid sudden turns or rapid speed changes.

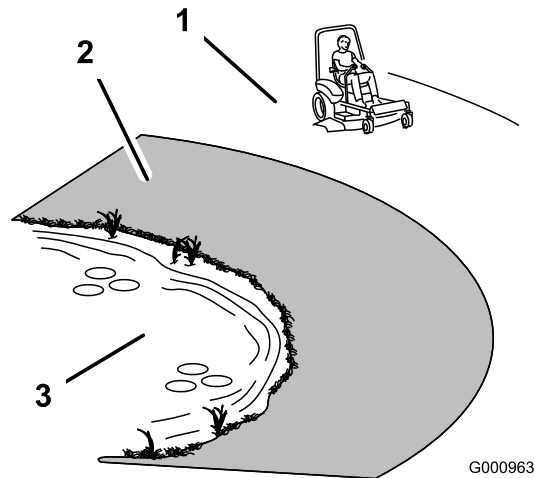

Figure 9

- | | |
|--|----------|
| 1. Safe Zone-use the Z Master here on slopes less than 15 degrees or flat areas. | 3. Water |
| 2. Danger Zone- use a walk behind mower and/or a hand trimmer on slopes greater than 15 degrees, near drop-offs and water. | |

⚠ CAUTION

This machine produces sound levels in excess of 85 dBA at the operators ear and can cause hearing loss through extended periods of exposure.

Wear hearing protection when operating this machine.

The use of protective equipment for eyes, ears, hands, feet and head is recommended.

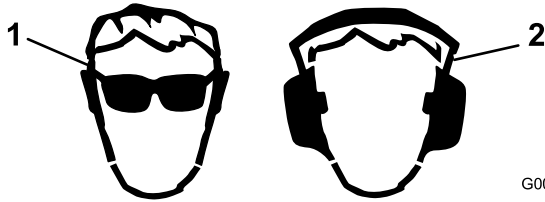

Figure 10

G009027

1. Wear safety glasses
2. Wear hearing protection

Operating the Parking Brake

Always set the parking brake when you stop the machine or leave it unattended.

Setting the Parking Brake

⚠ WARNING

Parking brake may not hold machine parked on a slope and could cause personal injury or property damage.

Do not park on slopes unless wheels are chocked or blocked.

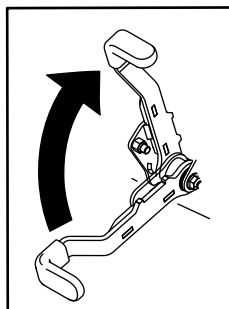
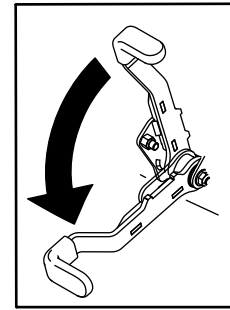

Figure 11

g027334

Releasing the Parking Brake



g027335

Figure 12

Operating the Mower-Blade-Control Switch (PTO)

The blade-control switch (PTO) starts and stops the mower blades and any powered attachments.

Engaging the Blade-Control Switch (PTO)

Note: Engaging the blade-control switch (PTO) with the throttle position at half or less will cause excessive wear to the drive belts.

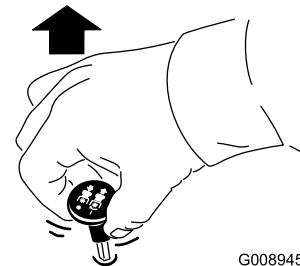

G008945

Figure 13

Disengaging the Blade-Control Switch (PTO)

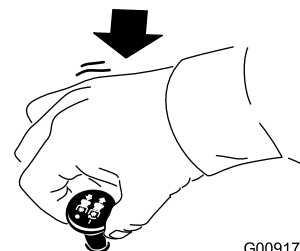

G009174

Figure 14

Operating the Throttle

The throttle control can be moved between **Fast** and **Slow** positions (Figure 15).

Always use the fast position when turning on the mower deck with the blade-control switch (PTO).

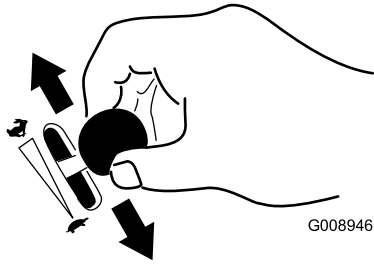

Figure 15

Operating the Choke

Use the choke to start a cold engine.

1. If the engine is cold, use the choke to start the engine.
2. Pull up on the choke knob to engage the choke before using the ignition switch (Figure 16).
3. Push down on the choke to disengage the choke after the engine has started (Figure 16).

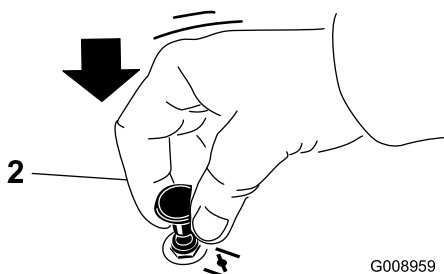
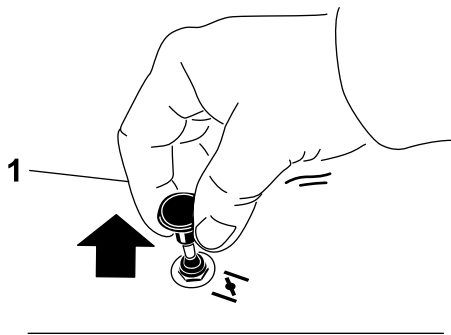

Figure 16

1. On

2. Off

Operating the Ignition Switch

1. Turn the ignition key to the Start position (Figure 17). When the engine starts, release the key.

Important: Do not engage starter for more than 5 seconds at a time. If the engine fails to start allow a 15 second cool-down period between attempts. Failure to follow these instructions can burn out the starter motor.

Note: Additional starting cycles may be required when starting the engine for the first time after the fuel system has been without fuel completely.

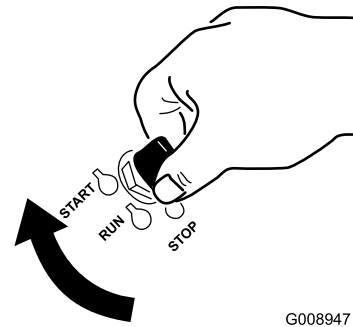

Figure 17

2. Turn the ignition key to stop to stop the engine.

Using the Fuel-Shutoff Valve

The fuel-shutoff valve is located under the seat. Move the seat forward to access it.

Close the fuel-shutoff valve for transport, maintenance, and storage.

Ensure the fuel-shutoff valve is open when starting the engine.

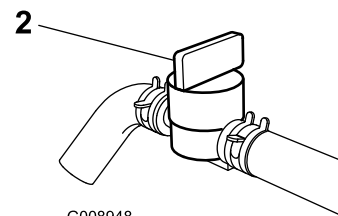
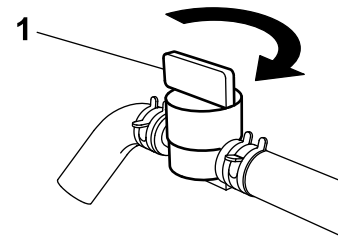

Figure 18

1. On

2. Off

Starting and Stopping the Engine

Starting the Engine

1. Raise the ROPS up and lock into place, sit on the seat and fasten the seat belt.
2. Move the motion controls to neutral-locked position.
3. Set the parking brake; refer to [Setting the Parking Brake \(page 20\)](#).
4. Move the blade-control switch (PTO) to the Off position ([Figure 19](#)).
5. Move the throttle lever midway between the Slow and Fast positions.

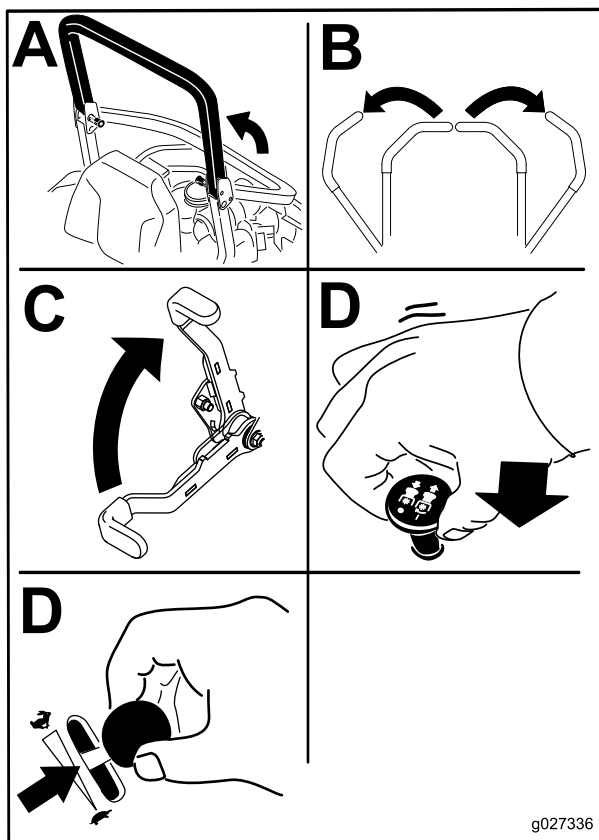

Figure 19

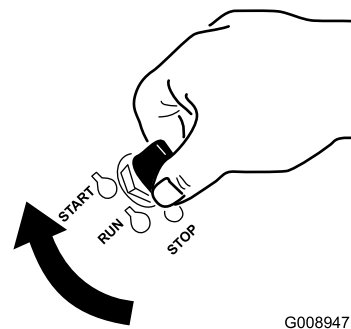

Figure 20

G008947

1. Off
2. Run
3. Start

Stopping the Engine

⚠ CAUTION

Children or bystanders may be injured if they move or attempt to operate the machine while it is unattended.

Always remove the ignition key and set the parking brake when leaving the machine unattended, even if just for a few minutes.

Let the engine idle at slow throttle (turtle) for 60 seconds before turning the ignition switch off.

6. Turn the ignition key to the Start position ([Figure 17](#)). When the engine starts, release the key.

Important: Do not engage starter for more than 5 seconds at a time. If the engine fails to start allow a 15 second cool-down period between attempts. Failure to follow these instructions can burn out the starter motor.

Note: Additional starting cycles may be required when starting the engine for the first time after the fuel system has been without fuel completely.

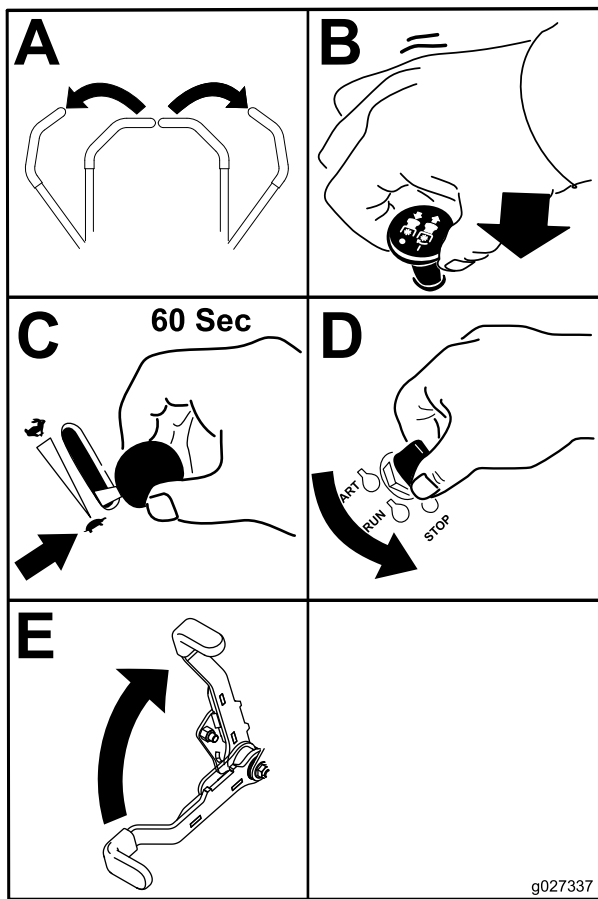

Figure 21

- The blade-control switch (PTO) is disengaged.
- The motion-control levers are in the neutral-locked position

The safety-interlock system also is designed to stop the engine when the motion-control levers are moved from the locked position with the parking brake engaged or if you rise from the seat when the PTO is engaged.

The hour meter has symbols to notify the user when the interlock component is in the correct position. When the component is in the correct position, a triangle will light up in the corresponding square.

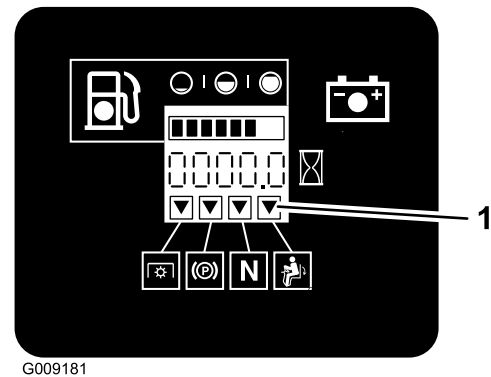

Figure 22

1. Triangles light up when the interlock components are in the correct position

Important: Make sure that the fuel-shutoff valve is closed before transporting or storing the machine, as fuel leakage may occur. Set the parking brake before transporting the machine. Make sure to remove the key, as the fuel pump may run and cause the battery to lose charge.

The Safety-Interlock System

⚠ CAUTION

If safety-interlock switches are disconnected or damaged the machine could operate unexpectedly, causing personal injury.

- Do not tamper with the interlock switches.
- Check the operation of the interlock switches daily, and replace any damaged switches before operating the machine.

Understanding the Safety-Interlock System

The safety-interlock system is designed to prevent the engine from starting unless:

- The parking brake is engaged.

Testing the Safety-Interlock System

Service Interval: Before each use or daily

Test the safety-interlock system before you use the machine each time. If the safety system does not operate as described below, have an Authorized Service Dealer repair the safety system immediately.

1. Sitting on the seat, engage the parking brake and move the blade-control switch (PTO) to on. Try starting the engine; the engine should not crank.
2. Sitting on the seat, engage the parking brake and move the blade-control switch (PTO) to off. Move either motion-control lever (out of the neutral-locked position). Try starting the engine; the engine should not crank. Repeat for other control lever.
3. Sitting on the seat, engage the parking brake, move the blade-control switch (PTO) to off and move the motion-control levers to neutral-lock position. Now start the engine. While the engine is running, release the parking brake, engage the blade-control switch (PTO) and rise slightly from the seat; the engine should stop.
4. Sitting on the seat, engage the parking brake, move the blade-control switch (PTO) to off and move the motion-control levers to neutral-lock position. Now start the engine. While the engine is running, center

either motion-control lever and move (forward or reverse); the engine should stop. Repeat for the other motion-control lever.

5. Sitting on the seat, disengage the parking brake, move the blade-control switch (PTO) to off and move the motion-control levers to neutral-lock position. Try starting the engine; the engine should not crank.

Driving Forward or Backward

The throttle control regulates the engine speed as measured in rpm (revolutions per minute). Place the throttle control in the fast position for best performance. Always operate in the full throttle position when mowing.

⚠ CAUTION

The machine can spin very rapidly. The operator may lose control of the machine and injure someone or damage the machine.

- Use caution when making turns.
- Slow the machine down before making sharp turns.

Using the Motion-Control Levers

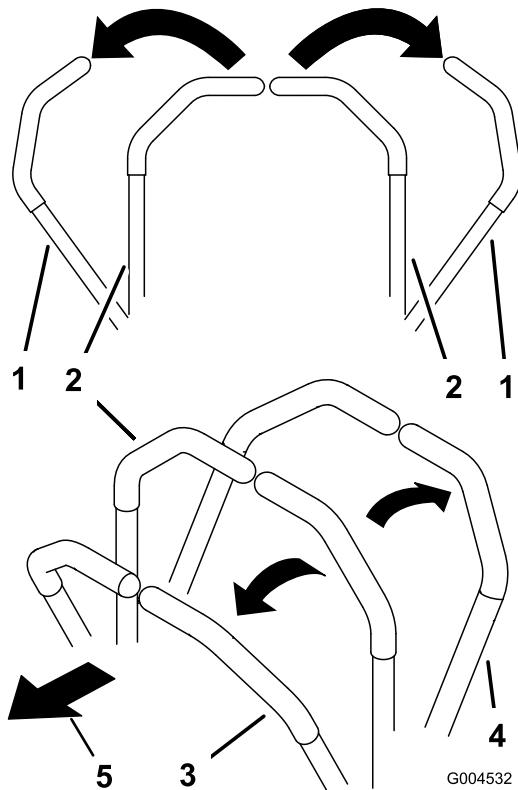

Figure 23

1. Motion-control lever—neutral-lock position
2. Center, unlocked position
3. Forward
4. Backward
5. Front of the machine

Driving Forward

Note: The engine will stop if the motion-control levers are moved with the parking brake engaged.

To stop, pull the motion-control levers to the neutral position.

1. Release the parking brake; refer to [Releasing the Parking Brake \(page 20\)](#).
2. Move the levers to the center, unlocked position.
3. To go forward, slowly push the motion-control levers forward ([Figure 24](#)).

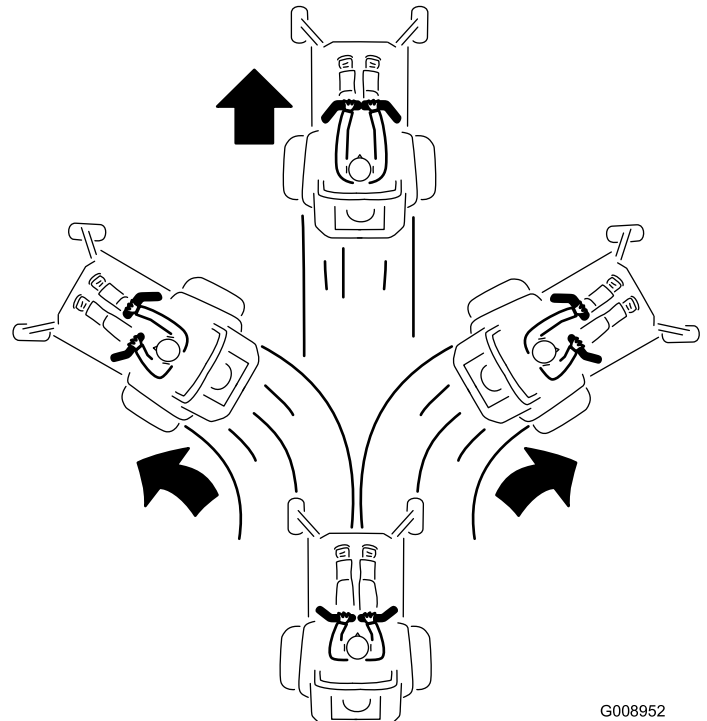
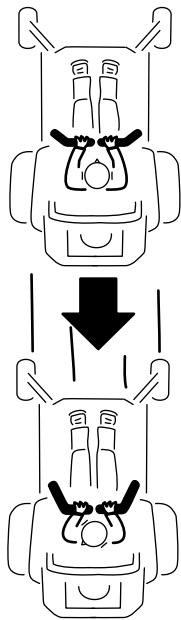

Figure 24

G008952

Driving Backward

1. Move the levers to the center, unlocked position.
2. To go backward, slowly pull the motion-control levers rearward ([Figure 25](#)).



G008953

Figure 25

Stopping the Machine

To stop the machine, move the motion-control levers to neutral and move them to the locked position, disengage the power take off (blade-control switch (PTO)), and turn the ignition key to the off position.

Set the parking brake when you leave the machine; refer to [Setting the Parking Brake \(page 20\)](#). Remember to remove the key from the ignition switch.

CAUTION

Children or bystanders may be injured if they move or attempt to operate the tractor while it is unattended.

Always remove the ignition key and set the parking brake when leaving the machine unattended, even if just for a few minutes.

Adjusting the Height of Cut

Using the Transport Lock

The transport lock has two positions and is used with the deck-lift pedal. There is a lock position and a unlock position for the transport position. The transport lock is used with the deck-lift pedal. Refer to [Figure 26](#)

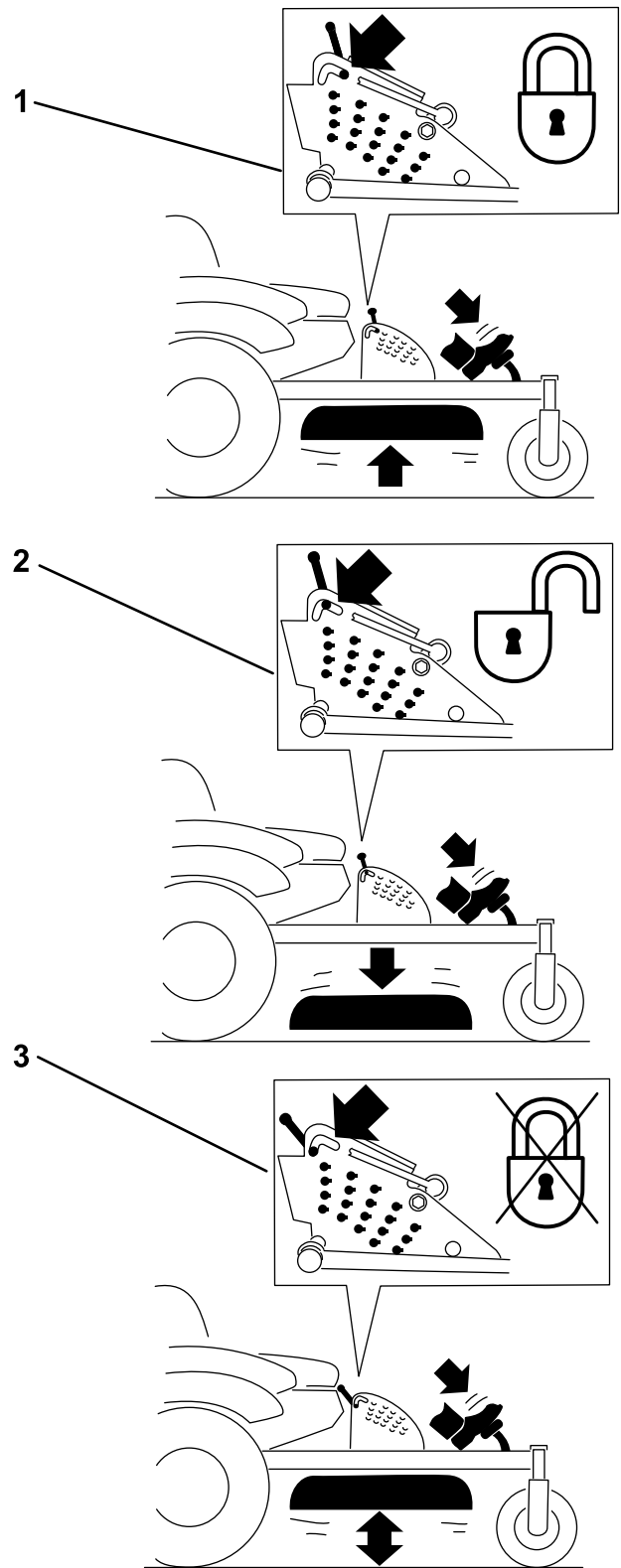

G008955

Figure 26

Transport Lock Positions

1. Transport lock
2. Lock position—mower deck will lock into transport position
3. Unlock position—does not lock the mower deck into transport position

Adjusting the Height-of-Cut Pin

The height of cut is adjusted from 25 to 140 mm (1 to 5-1/2 inches) in 6 mm (1/4 inch) increments by moving the clevis pin into different hole locations.

1. Move the transport lock to the lock position.
2. Push on the deck-lift pedal with your foot and raise the mower deck to the transport position (also the 140 mm (5-1/2 inch) cutting-height position); refer to [Figure 27](#).
3. To adjust, rotate the pin 90 degrees and remove the pin from the height-of-cut bracket ([Figure 27](#)).
4. Select a hole in the height-of-cut bracket corresponding to the height of cut desired, and insert the pin ([Figure 27](#)).
5. Push on the deck lift, pull back on the transport lock, and slowly lower the mower deck.

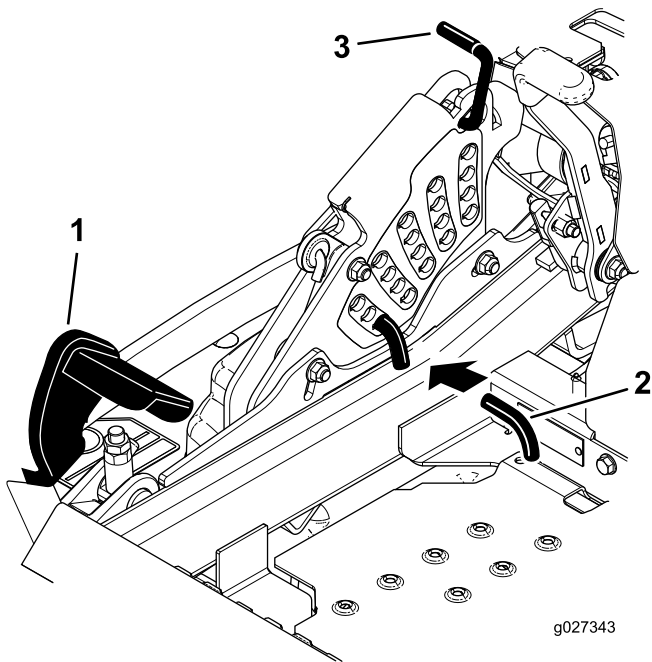

Figure 27

1. Deck-lift pedal
2. Height-of-cut pin
3. Transport lock

Adjusting the Anti-Scalp Rollers

Whenever you change the height of cut, it is recommended to adjust the height of the anti-scalp rollers.

1. Disengage the blade-control switch (PTO), move the motion-control levers to the neutral-locked position and set the parking brake.
2. Stop the engine, remove the key, and wait for all moving parts to stop before leaving the operating position.

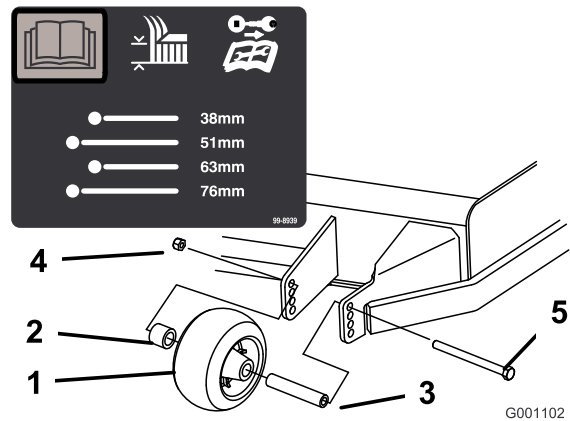

Figure 28

1. Anti-scalp roller
2. Spacer
3. Bushing
4. Flange nut
5. Bolt

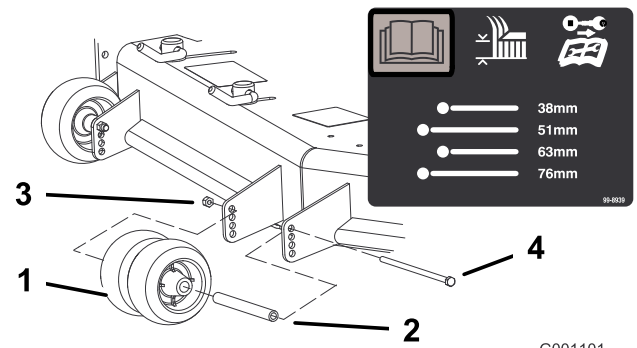

Figure 29

1. Anti-scalp roller
2. Bushing
3. Flange nut
4. Bolt

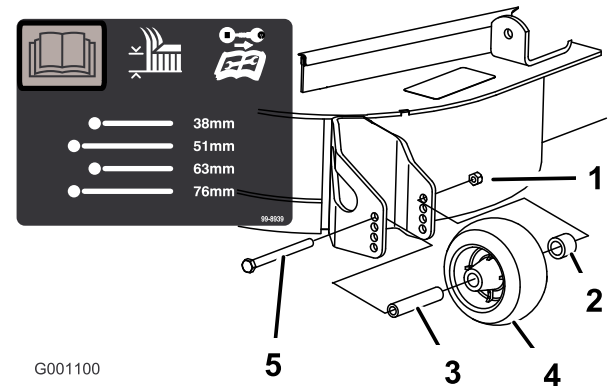

Figure 30

1. Anti-scalp roller
2. Spacer
3. Bushing
4. Flange Nut
5. Bolt

Adjusting the Flow-Baffle-Cam Locks

This procedure is applicable only to machines with the flow baffle locks. Certain models will have nuts and bolts in-place of the flow baffle locks and can be adjusted the same.

The mower discharge flow can be adjusted for different types of mowing conditions. Position the cam locks and baffle to give the best quality of cut.

1. Disengage the blade-control switch (PTO), move the motion-control levers to the neutral-locked position and set the parking brake.
2. Stop the engine, remove the key, and wait for all moving parts to stop before leaving the operating position.
3. To adjust the cam locks, swing the lever up to loosen the cam lock (Figure 31).
4. Adjust the baffle and cam locks in the slots to the desired discharge flow.
5. Swing the lever back over to tighten the baffle and cam locks (Figure 31).
6. If the cam locks do not lock the baffle into place or it is too tight, loosen the lever and then rotate the cam lock. Adjust the cam lock until the desired locking pressure is achieved.

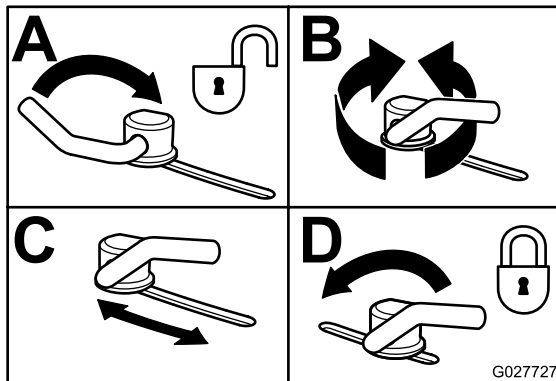

Figure 31

- Use in dry conditions.
- Use for smaller grass clippings.
- Use to propel grass clippings farther away from the mower.

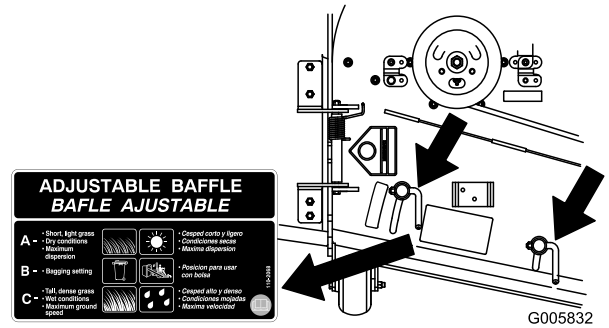

Figure 32

Position B

Use this position when bagging. Always align it with the blower opening.

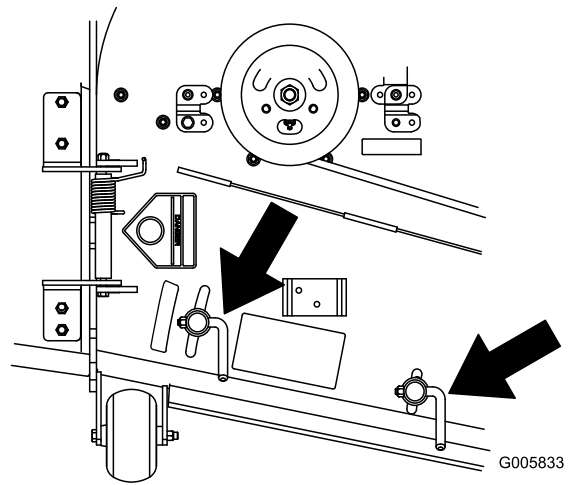

Figure 33

Positioning the Flow Baffle

The following figures are only recommendations for use. Adjustments will vary by grass type, moisture content, and height of grass.

Note: If the engine power draws down and the mower ground speed is the same, open up the baffle.

Position A

This is the full rear position. The suggested use for this position is as follows:

- Use for short, light mowing conditions.

Position C

This is the full open position. The suggested use for this position is as follows:

- Use in tall, dense grass-mowing conditions.
- Use in wet conditions.
- Use to lower the engine power consumption.
- Use to allow increased ground speed in heavy conditions.
- This position offers benefits similar to those of the Toro SFS mower.

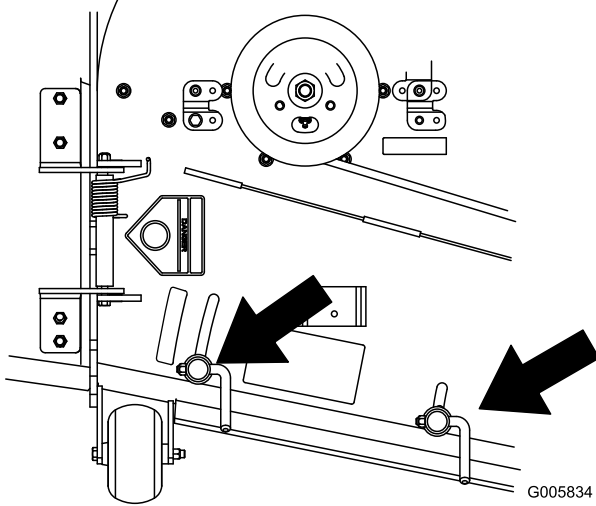

Figure 34

Positioning the Seat

The seat can move forward and backward. Position the seat where you have the best control of the machine and are most comfortable.

To adjust, move the lever sideways to unlock seat (Figure 35).

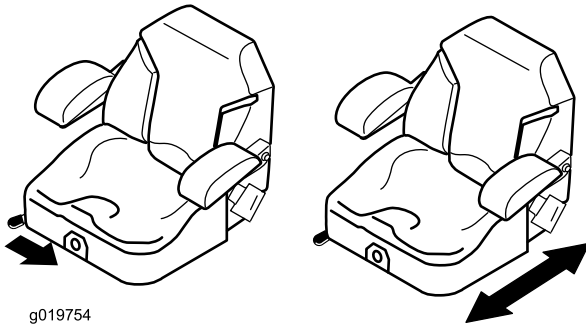

Figure 35

Changing the Seat Suspension

The seat is adjustable to provide a smooth and comfortable ride. Position the seat where you are most comfortable.

To adjust it, turn the knob in front either direction to provide the best comfort (Figure 36).

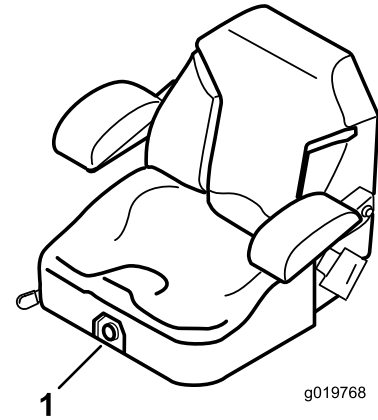

Figure 36

1. Seat suspension knob

Using the Drive-Wheel Release Valves

⚠ WARNING

Hands may become entangled in the rotating drive components below the engine deck, which could result in serious injury.

Stop the engine, remove the key, and allow all moving parts to stop before accessing the drive-wheel release valves.

⚠ WARNING

The engine and the hydraulic drive units can become very hot. Touching a hot engine or hydraulic drive units can cause severe burns.

Allow the engine and hydraulic drive units to cool completely before accessing the drive-wheel release valves.

The drive-wheel release valves are located in the back of each hydraulic drive unit, under the seat.

Note: Make sure that the release valves are in the fully horizontal position when operating the machine or severe damage to the hydraulic system can occur.

1. Disengage the PTO (blade-control switch) and turn the ignition key to off. Move the levers to neutral-locked position and apply parking brake. Remove the key.

2. Rotate the release valve levers vertically to push the machine. This allows hydraulic oil to bypass the pump enabling the wheels to turn (Figure 37).
3. Disengage the parking brake before pushing the machine.

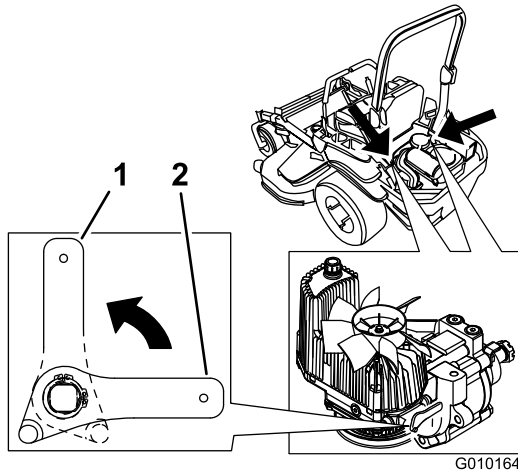

Figure 37

1. Vertical to push the machine
2. Horizontal to run the machine

4. Rotate the release-valve levers horizontally to run the machine (Figure 37).

Using the Side Discharge

The mower has a hinged grass deflector that disperses clippings to the side and down toward the turf.

⚠ DANGER

Without a grass deflector, discharge cover, or complete grass catcher assembly mounted in place, you and others are exposed to blade contact and thrown debris. Contact with rotating mower blade(s) and thrown debris will cause injury or death.

- Never remove the grass deflector from the mower, because the grass deflector routes material down toward the turf. If the grass deflector is ever damaged, replace it immediately.
- Never put your hands or feet under the mower.
- Never try to clear the discharge area or mower blades unless you move the power take off (blade-control switch / PTO) to the off position, rotate the ignition key to off and remove the key.
- Make sure that the grass deflector is in the down position.

Transporting the Machine

Use a heavy-duty trailer or truck to transport the machine. Ensure that the trailer or truck has all necessary brakes, lighting, and marking as required by law. Please carefully read all the safety instructions. Knowing this information could help you, your family, pets, or bystanders avoid injury.

⚠ WARNING

Driving on the street or roadway without turn signals, lights, reflective markings, or a slow moving vehicle emblem is dangerous and can lead to accidents causing personal injury.

Do not drive machine on a public street or roadway.

To transport the machine:

1. If using a trailer, connect it to the towing vehicle and connect the safety chains.
2. If applicable, connect the trailer brakes.
3. Load the machine onto the trailer or truck.
4. Stop the engine, remove the key, set the brake, and close the fuel valve.
5. Use the metal tie down loops on the machine to securely fasten the machine to the trailer or truck with straps, chains, cable, or ropes (Figure 38).

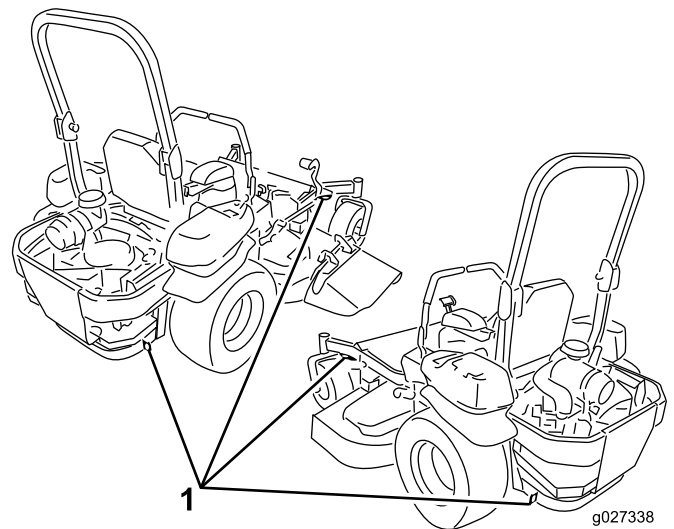

Figure 38

1. Traction unit tie down loops

Loading the Machine

Use extreme caution when loading or unloading machines onto a trailer or a truck. Use a full-width ramp that is wider than the machine for this procedure. Back up ramps and drive forward down ramps (Figure 39).

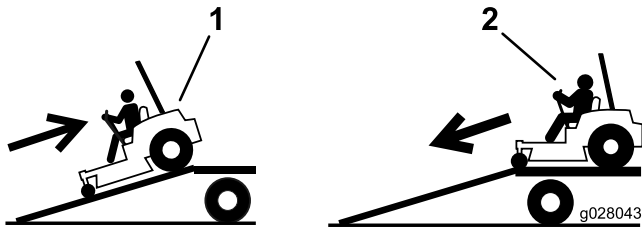

Figure 39

1. Back up ramps
2. Drive forward down ramps

Important: Do not use narrow individual ramps for each side of the machine.

Ensure the ramp is long enough so that the angle with the ground does not exceed 15 degrees (Figure 40). On flat ground, this requires a ramp to be at least four times (4X) as long as the height of the trailer or truck bed to the ground. A steeper angle may cause mower components to get caught as the unit moves from the ramp to the trailer or truck. Steeper angles may also cause the machine to tip or lose control. If loading on or near a slope, position the trailer or truck so that it is on the down side of the slope and the ramp extends up the slope. This will minimize the ramp angle.

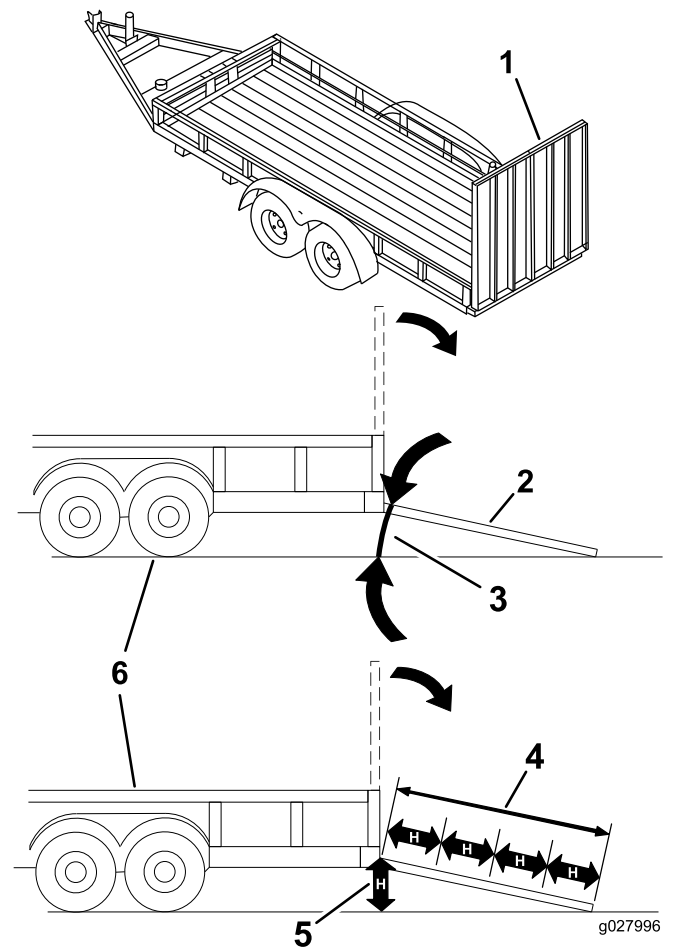

Figure 40

1. Full-width ramp in stowed position
2. Side view of full-width ramp in loading position
3. Not greater than 15 degrees
4. Ramp is at least four times (4X) as long as the height of the trailer or truck bed to the ground
5. H= height of the trailer or truck bed to the ground
6. Trailer

⚠ WARNING

Loading a machine onto a trailer or truck increases the possibility of tip-over and could cause serious injury or death.

- Use extreme caution when operating a machine on a ramp.
- Ensure that the ROPS is in the up position and use the seat belt when loading or unloading the machine. Ensure that the ROPS will clear the top of an enclosed trailer.
- Use only a full-width ramp; do not use individual ramps for each side of the machine.
- Do not exceed a 15-degree angle between the ramp and the ground or between the ramp and the trailer or truck.
- Ensure the length of ramp is at least four times (4X) as long as the height of the trailer or truck bed to the ground. This will ensure that ramp angle does not exceed 15 degrees on flat ground.
- Back up ramps and drive forward down ramps.
- Avoid sudden acceleration or deceleration while driving the machine on a ramp as this could cause a loss of control or a tip-over situation.

Using the Z Stand®

The Z Stand® raises the front end of the machine to allow you to clean the mower and remove the blades.

⚠ WARNING

The machine could fall onto someone and cause serious injury or death.

- Use extreme caution when operating the machine on the Z Stand®.
- Use only for cleaning the mower and removing the blades.
- Do not keep the machine on the Z Stand for extended periods of time.
- Always turn the engine off, set the parking brake, and remove the key before performing any maintenance to the mower.

Driving up onto the Z Stand

Important: Use the Z Stand on a level surface.

1. Raise the mower to the transport position.
2. Remove the bracket pin (Figure 41).

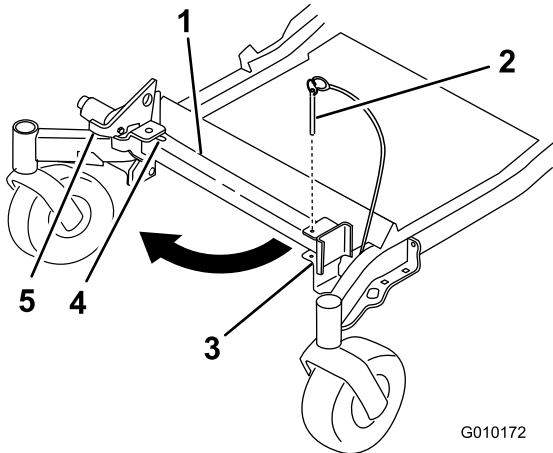

Figure 41

- | | |
|----------------|-------------------|
| 1. Z Stand | 4. Bottom of slot |
| 2. Bracket Pin | 5. Latch |
| 3. Bracket | |

3. Raise the latch. Swing the stand foot out front and slide stand toward machine, into the bottom of slot (Figure 41 and Figure 42).

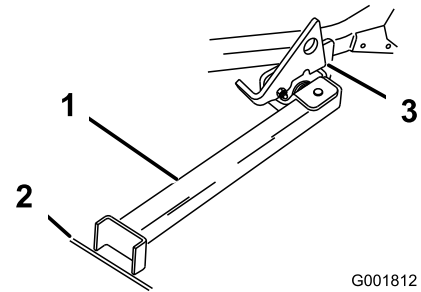

Figure 42

1. Z Stand (Positioned in slot)
 2. Crack in side walk or turf
 3. Latch resting on pivot tab
4. Set the foot of stand on the ground and rest the latch on the pivot tab (Figure 42).
 5. Start the engine and put it at half throttle.
- Note:** For best results, place the foot of stand into seams in sidewalks or into the turf (Figure 42).
6. Drive onto the stand. Stop when the latch drops over the tab into the locked position (Figure 42). Once onto the stand, engage the parking brake and turn off the engine.
 7. Chock or block the drive wheels.

⚠ WARNING

Parking brake may not hold machine parked on Z Stand and could cause personal injury or property damage.

Do not park on Z Stand unless wheels are chocked or blocked.

8. Perform the maintenance.

Driving off the Z Stand

1. Remove the chocks or blocks.
2. Raise the latch to the unlocked position (Figure 43).

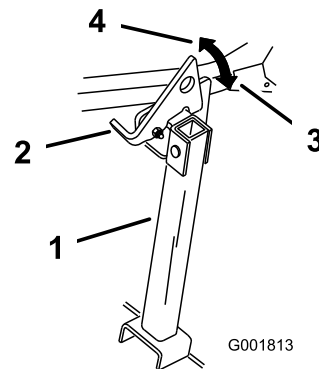

Figure 43

- | | |
|------------|----------------------|
| 1. Z Stand | 3. Locked position |
| 2. Latch | 4. Unlocked position |

3. Start the engine and place it at half throttle. Disengage the parking brake.
4. Slowly drive backwards off of the stand.
5. Return the stand to its rest position (Figure 41).

Operating Tips

Maximizing Cutting Efficiency

For best mowing and maximum air circulation, operate the engine at the fast throttle position. Air is required to thoroughly cut grass clippings, so do not set the height of cut so low as to totally surround the mower by uncut grass. Always try to have one side of the mower free from uncut grass, which allows air to be drawn into the mower.

Cutting a Lawn for the First Time

Cut grass slightly longer than normal to ensure the cutting height of the mower does not scalp any uneven ground. However, the cutting height used in the past is generally the best one to use. When cutting grass longer than six inches tall, you may want to cut the lawn twice to ensure an acceptable quality of cut.

Cutting 1/3 of the Grass Blade

It is best to cut only about 1/3 of the grass blade. Cutting more than that is not recommended unless grass is sparse, or it is late fall when grass grows more slowly.

Alternating Mowing Direction

Alternate mowing direction to keep the grass standing straight. This also helps disperse clippings, which enhances decomposition and fertilization.

Mowing at Correct Intervals

Normally, mow every 4 days. However, grass grows at different rates at different times. So to maintain the same cutting height, which is a good practice, mow more often in early spring. As the grass growth rate slows in midsummer, mow less frequently. If you cannot mow for an extended period, first mow at a high cutting height; then mow again 2 days later at a lower height setting.

Choosing the Best Speed

To improve cut quality, use a slower ground speed in certain conditions.

Avoiding Cutting Too Low

If the cutting width of the mower is wider than the mower you previously used, raise the cutting height to ensure that uneven turf is not cut too short.

Cutting Long Grass

If the grass is ever allowed to grow slightly longer than normal, or if it contains a high degree of moisture, raise the cutting height higher than usual and cut the grass at this setting. Then cut the grass again using the lower, normal setting.

Stopping

If the you must stop the forward motion of the machine while mowing, a clump of grass clippings may drop onto the lawn. To avoid this, move onto a previously cut area with the blades engaged.

Keeping the Underside of the Mower Clean

Clean clippings and dirt from the underside of the mower after each use. If grass and dirt build up inside the mower, cutting quality will eventually become unsatisfactory.

Maintaining the Blade

Maintain a sharp blade throughout the cutting season because a sharp blade cuts cleanly without tearing or shredding the grass blades. Tearing and shredding turns grass brown at the edges, which slows growth and increases the chance of disease. Check the cutter blades daily for sharpness, and for any wear or damage. File down any nicks and sharpen the blades as necessary. If a blade is damaged or worn, replace it immediately with a genuine Toro replacement blade.

Maintenance

Recommended Maintenance Schedule(s)

Maintenance Service Interval	Maintenance Procedure
After the first 8 hours	<ul style="list-style-type: none"> • Change the engine oil.
After the first 100 hours	<ul style="list-style-type: none"> • Check the wheel lug-nut torque. • Check the wheel hub slotted-nut torque. • Check the parking brake adjustment.
After the first 250 hours	<ul style="list-style-type: none"> • Change the hydraulic filters and hydraulic oil when using any type of oil.
Before each use or daily	<ul style="list-style-type: none"> • Check the safety-interlock system. • Check the engine-oil level. • Check the seat belt. • Check the rollover protection system (ROPS) knobs. • Clean the engine screen. • Clean the oil cooler (model 74925TE only). • Check and clean the hydraulic-unit shrouds. • Check the mower blades. • Clean the mower deck.
Every 50 hours	<ul style="list-style-type: none"> • Grease the mower deck spindles and idler arm. • Check the spark arrester (if equipped). • Check the tire pressure. • Inspect the belts for cracks and wear. • Check the hydraulic oil level.
Every 100 hours	<ul style="list-style-type: none"> • Lubricate the mower deck-lift pivots. • Change the engine oil (more often in dirty or dusty conditions). • Check and gap the spark plugs. • Check and clean engine cooling fins and shrouds.
Every 200 hours	<ul style="list-style-type: none"> • Change the engine-oil filter.
Every 250 hours	<ul style="list-style-type: none"> • Replace the primary air filter. • Check the secondary air filter. • Change the hydraulic filters and hydraulic oil when using Mobil® 1 oil (more often in dirty or dusty conditions).
Every 500 hours	<ul style="list-style-type: none"> • Replace the secondary air filter. • Replace the fuel filter (more often in dirty or dusty conditions). • Check the wheel lug-nut torque. • Check the wheel hub slotted-nut torque. • Adjust the caster pivot bearing. • Check the parking brake adjustment. • Change the hydraulic filters and hydraulic oil when using Toro® HYPR-OIL™ 500 hydraulic oil (more often in dirty or dusty conditions).
Monthly	<ul style="list-style-type: none"> • Check the battery.
Yearly	<ul style="list-style-type: none"> • Grease the pump belt idler arm. • Grease the front caster pivots (more often in dirty or dusty conditions). • Repack the front caster wheel bearings (more often in dirty or dusty conditions). • Lubricate the caster wheel hubs
Yearly or before storage	<ul style="list-style-type: none"> • Paint chipped surfaces. • Check all maintenance procedures listed above before storage.

Important: Refer to your engine operator's manual for additional maintenance procedures.

⚠ CAUTION

If you leave the key in the ignition switch, someone could accidentally start the engine and seriously injure you or other bystanders.

Remove the key from the ignition before you do any maintenance.

Premaintenance Procedures

Releasing the Mower-Deck Curtain

Loosen the bottom bolt of the curtain to release the mower-deck curtain and access the top of the mower deck (Figure 44). Tighten the bolt after maintenance to install the curtain.

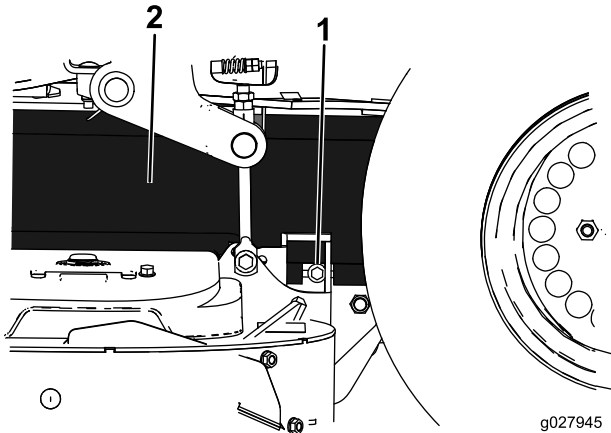

Figure 44

1. Bolt

2. Curtain

Removing the Sheet-Metal Guard

Loosen the 2 front bolts and remove the sheet-metal guard to access the mower belts and spindles (Figure 45). Place the sheet-metal guard and tighten the bolts after maintenance.

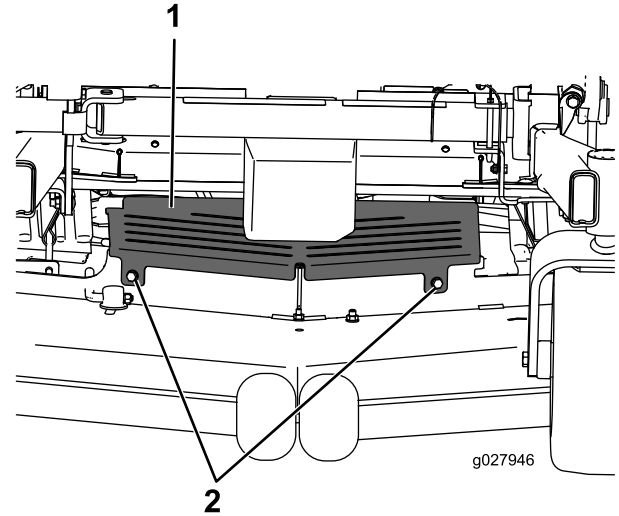

Figure 45

1. Sheet-metal guard

2. Bolt

Lubrication

Lubricating the Machine

Grease more frequently when operating conditions are extremely dusty or sandy.

Grease Type: #2 general-purpose lithium-based or molybdenum-based grease

1. Disengage the blade-control switch (PTO), move the motion-control levers to the neutral-locked position, and set the parking brake.
2. Stop the engine, remove the key, and wait for all moving parts to stop before leaving the operating position.
3. Clean the grease fittings with a rag. Make sure to scrape any paint off the front of the fitting(s).
4. Connect a grease gun to the fitting. Pump grease into the fittings until grease begins to ooze out of the bearings.
5. Wipe up any excess grease.

Using Light Oil or Spray Lubrication

Service Interval: Every 100 hours

Deck-lift pivots.

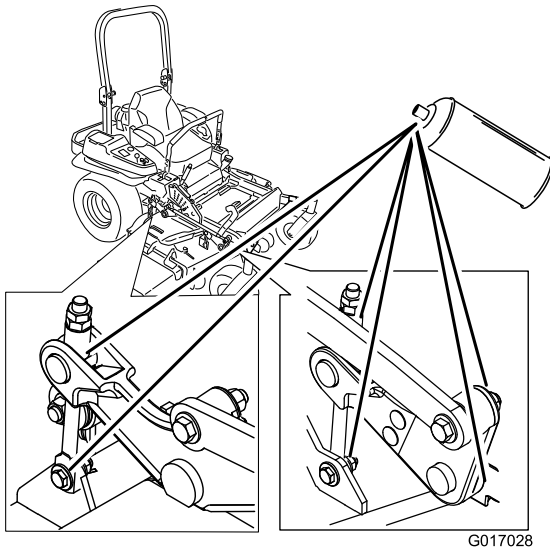

Figure 46

Greasing the Mower

Service Interval: Every 50 hours—Grease the mower deck spindles and idler arm.

Yearly—Grease the pump belt idler arm.

Yearly—Grease the front caster pivots (more often in dirty or dusty conditions).

Yearly—Repack the front caster wheel bearings (more often in dirty or dusty conditions).

Important: Make sure that the cutting unit spindles are full of grease weekly.

1. Disengage the blade-control switch (PTO), move the motion-control levers to the neutral-locked position, and set the parking brake.
2. Stop the engine, remove the key, and wait for all moving parts to stop before leaving the operating position.
3. Remove the sheet metal guard. Refer to [Removing the Sheet-Metal Guard \(page 35\)](#).
4. Grease the mower deck idler pulley pivot until grease come out the bottom ([Figure 47](#)).
5. Grease the fittings on the top of the 3 spindle bearings until grease comes out ([Figure 47](#)).

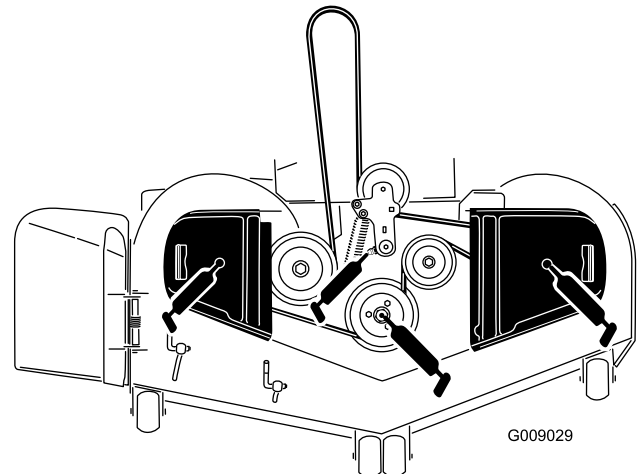

Figure 47

6. Grease the drive belt idler arm ([Figure 48](#)).

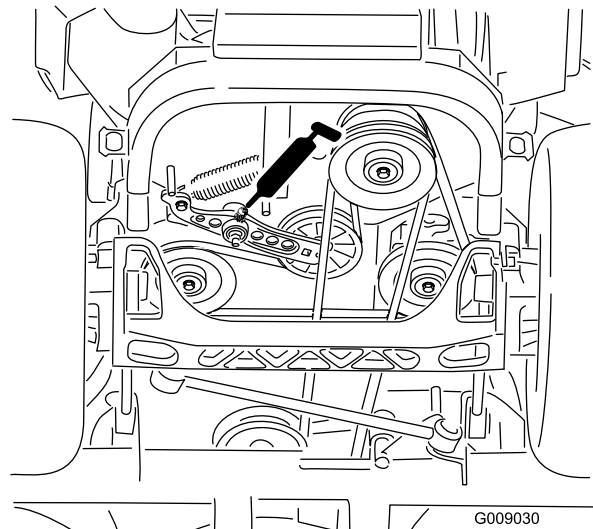

Figure 48

7. Remove the dust cap and adjust the caster pivots. Keep the dust cap off until greasing is complete. Refer to [Adjusting the Caster Pivot Bearing \(page 47\)](#)

8. Remove the hex plug. Thread a grease fitting into the hole.
9. Pump grease into the fitting until it oozes out around the top bearing.
10. Remove the grease fitting from the hole.
11. Install the hex plug and dust cap (Figure 49).

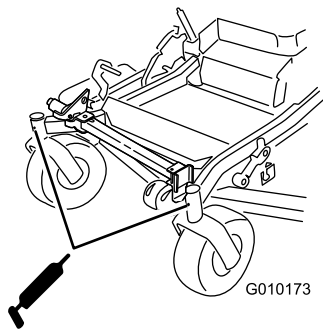

Figure 49

12. Install the sheet metal guard. Refer to [Removing the Sheet-Metal Guard](#) (page 35).

Lubricating the Caster Wheel Hubs

Service Interval: Yearly

1. Stop the engine, wait for all moving parts to stop, and remove the key. Engage the parking brake.

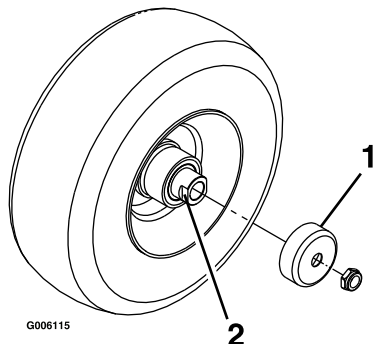

Figure 50

1. Seal guard
2. Spacer nut with wrench flats

2. Raise the front of the machine up, and support it with jack stands (or equivalent support) just high enough to allow the front wheels to turn freely.
3. Remove the caster wheel from the caster forks.
4. Remove the seal guards from the wheel hub.
5. Remove one of the spacer nuts from the axle assembly in the caster wheel. Note that thread-locking adhesive has been applied to lock the spacer nuts to the axle. Remove the axle (with the other spacer nut still assembled to it) from the wheel assembly.

6. Pry out seals, and inspect the bearings for wear or damage and replace them if necessary.
7. Pack the bearings with a general-purpose grease.
8. Insert one bearing, one new seal into the wheel.

Note: The seals must be replaced.

9. If the axle assembly has had both spacer nuts removed (or broken loose), apply a thread-locking adhesive to one spacer nut and thread it onto the axle with the wrench flats facing outward. Do not thread the spacer nut all the way onto the end of the axle. Leave approximately 3 mm (1/8 inch) from the outer surface of the spacer nut to the end of the axle inside the nut.
10. Insert the assembled nut and axle into the wheel on the side of the wheel with the new seal and bearing.
11. With the open end of the wheel facing up, fill the area inside the wheel around the axle full of general-purpose grease.
12. Insert the second bearing and a new seal into the wheel.
13. Apply a thread-locking adhesive to the 2nd spacer nut and thread it onto the axle with the wrench flats facing outward.
14. Torque the nut to 8 to 9 N-m (75 to 80 in-lb), loosen it, then torque it to 2 to 3 N-m (20 to 25 in-lb). Make sure that the axle does not extend beyond either nut.
15. Install the seal guards over the wheel hub and insert the wheel into the caster fork. Install the caster bolt and tighten the nut fully.
16. Remove the jack stands.

Important: To prevent seal and bearing damage, check the bearing adjustment often. Spin the caster wheel. The wheel should not spin freely (more than 1 or 2 revolutions) or have any side play. If the wheel spins freely, adjust the torque on spacer nut until there is a slight amount of drag. Apply thread-locking adhesive.

Engine Maintenance

⚠ WARNING

Contact with hot surfaces may cause personal injury.

Keep hands, feet, face, clothing and other body parts away the muffler and other hot surfaces.

Servicing the Air Cleaner

Service Interval: Every 250 hours—Replace the primary air filter.

Every 250 hours—Check the secondary air filter.

Every 500 hours—Replace the secondary air filter.

Note: Service the air cleaner more frequently if operating conditions are extremely dusty or sandy.

Removing the Filters

1. Disengage the PTO, move the motion-control levers to the neutral-locked position, and set the parking brake.
2. Stop the engine, remove the key, and wait for all moving parts to stop before leaving the operating position.
3. Push down to release the retaining clamps on the air cleaner and pull the air cleaner cover off of the air cleaner body (Figure 51).
4. Clean the inside of the air cleaner cover with compressed air.
5. Gently slide the primary filter out of the air cleaner body (Figure 51). Avoid knocking the filter into the side of the body.
6. Remove the secondary filter only if you intend to replace it.

Important: Never attempt to clean the secondary filter. If the secondary filter is dirty, then the primary filter is damaged and you should replace both filters.

7. Inspect the primary filter for damage by looking into the filter while shining a bright light on the outside of the filter. Holes in the filter will appear as bright spots. If the filter is damaged discard it.

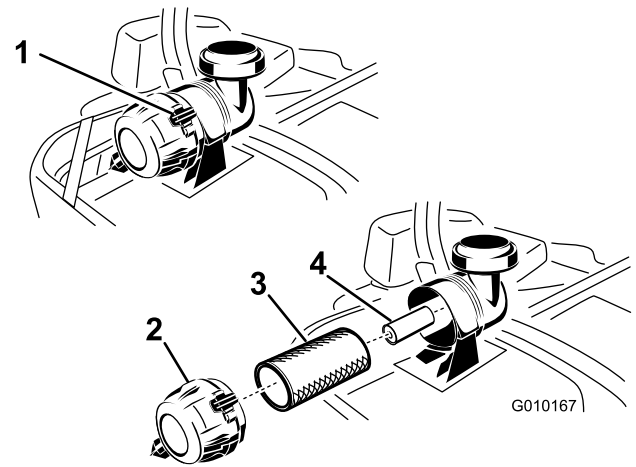

Figure 51

- | | |
|-----------------------|-------------------------|
| 1. Air cleaner clamps | 3. Primary air filter |
| 2. Air cleaner cover | 4. Secondary air filter |

Servicing the Primary Filter

1. Do not clean the paper filter, replace it (Figure 51).
2. Inspect the element for tears, an oily film, or damage to the rubber seal.
3. Replace the paper element if it is damaged.

Servicing the Secondary Filter

Do not clean the secondary filter, replace it.

Important: Never attempt to clean the secondary filter. If the secondary filter is dirty, then the primary filter is damaged and you should replace both filters.

Installing the Filters

Important: To prevent engine damage, always operate the engine with both air filters and cover installed.

1. If installing new filters, check each filter for shipping damage. Do not use a damaged filter.
2. If the secondary filter is being replaced, carefully slide it into the filter body (Figure 51).
3. Carefully slide the primary filter over the secondary filter (Figure 51). Ensure that it is fully seated by pushing on the outer rim of the filter while installing it.

Important: Do not press on the soft inside area of the filter.

4. Install the air cleaner cover with the breather cap down and rotate so the retaining clamps lock the cover in place (Figure 51).

Servicing the Engine Oil

Oil Type: Detergent oil (API service SG, SH, SJ, or SL)

Oil Capacity:

- **Model 74919TE:** with a filter change, 2.1 L (2.2 US qt); without a filter change, 1.8 L (1.9 US qt)
- **Model 74925TE:** with a filter change, 2.3 L (2.4 US qt); without a filter change, 2.1 L (2.2 US qt)

Viscosity: See the table below.

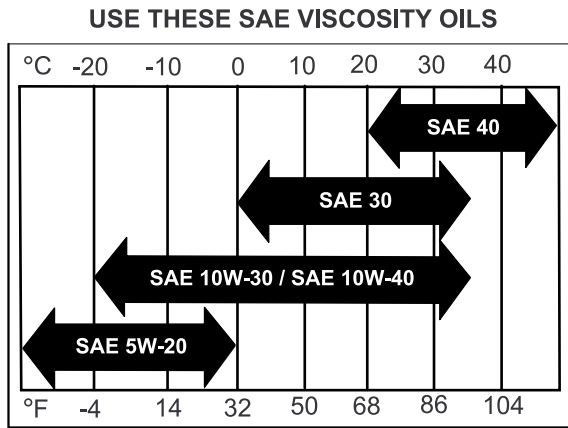

Figure 52

Note: Use of multi-grade oils (5W-20, 10W-30, or 10W-40) will increase oil consumption. Check the oil level more frequently when using them.

Checking the Engine-Oil Level

Service Interval: Before each use or daily

Note: Check the oil when the engine is cold.

⚠ WARNING

Contact with hot surfaces may cause personal injury.

Keep hands, feet, face, clothing, and other body parts away from the muffler and other hot surfaces.

Important: Do not overfill the crankcase with oil, because damage to the engine may result. Do not run the engine with oil below the low mark, because the engine may be damaged.

1. Disengage the PTO, move the motion-control levers to the neutral-locked position, and set the parking brake.
2. Stop the engine, remove the key, and wait for all moving parts to stop before leaving the operating position (Figure 53).

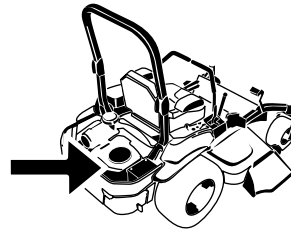

G010168

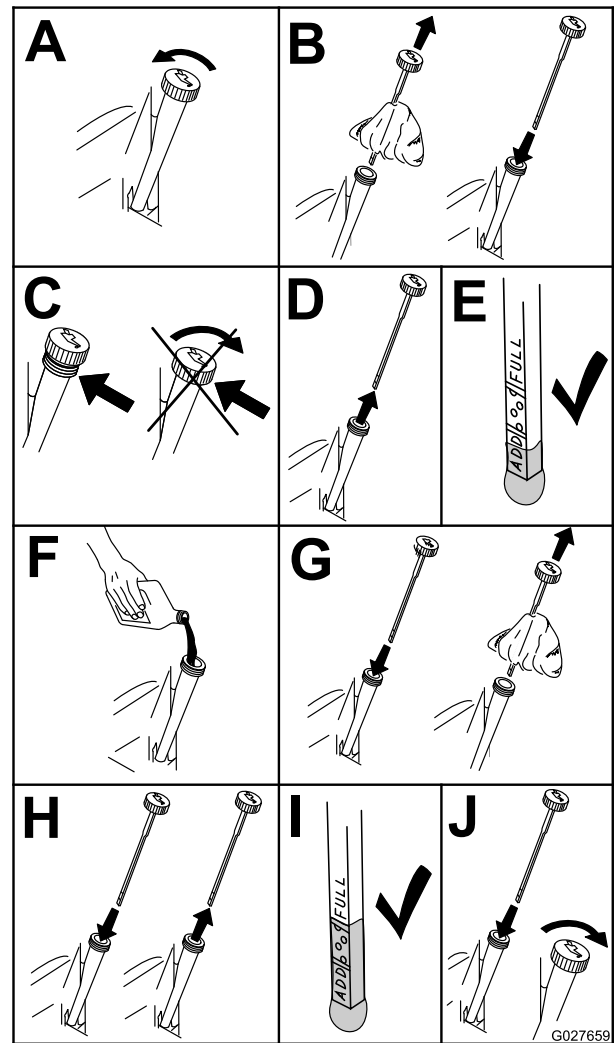

Figure 53

Changing the Engine Oil

Service Interval: After the first 8 hours

Every 100 hours (more often in dirty or dusty conditions).

Note: Dispose of the used oil at a recycling center.

1. Start the engine and let it run for 5 minutes. This warms the oil so it drains better.
2. Park the machine so that the rear is slightly lower than the front to ensure that the oil drains completely.
3. Disengage the PTO, move the motion-control levers to the neutral-locked position and set the parking brake.
4. Stop the engine, remove the key, and wait for all moving parts to stop before leaving the operating position (Figure 54).

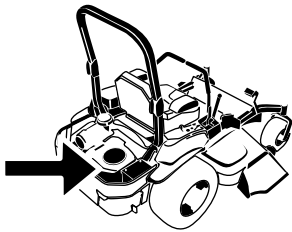

G010168

5. Slowly pour approximately 80% of the specified oil into the filler tube and slowly add the additional oil to bring it to the **Full** mark (Figure 55).

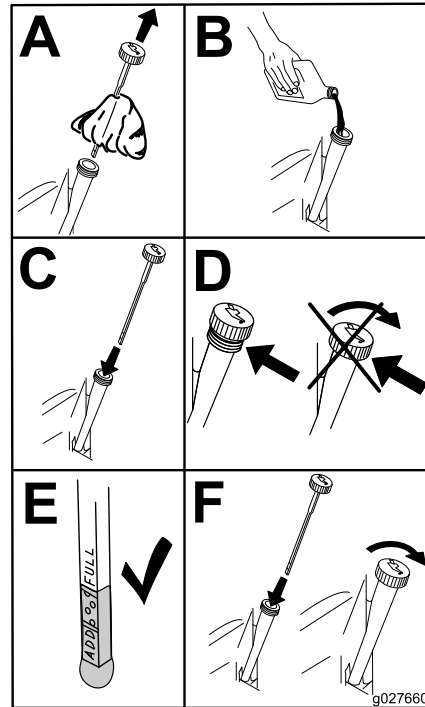

Figure 55

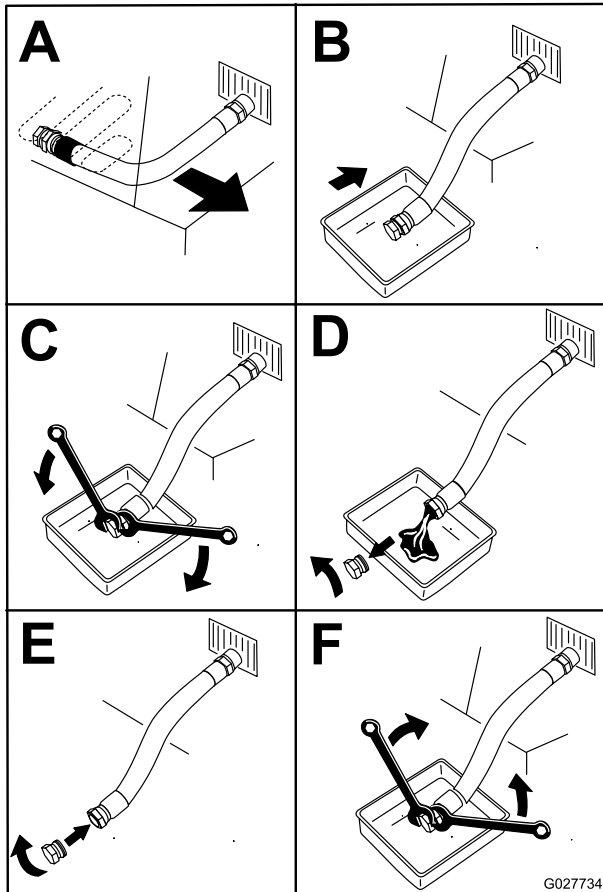

Figure 54

6. Start the engine and drive to a flat area. Check the oil level again.

Changing the Engine-Oil Filter

Service Interval: Every 200 hours

Note: Change the engine-oil filter more frequently when operating conditions are extremely dusty or sandy.

1. Drain the oil from the engine; refer to [Changing the Engine Oil](#) (page 40).
2. Change the engine-oil filter (Figure 56).

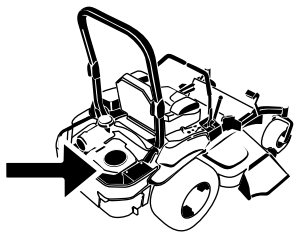

G010168

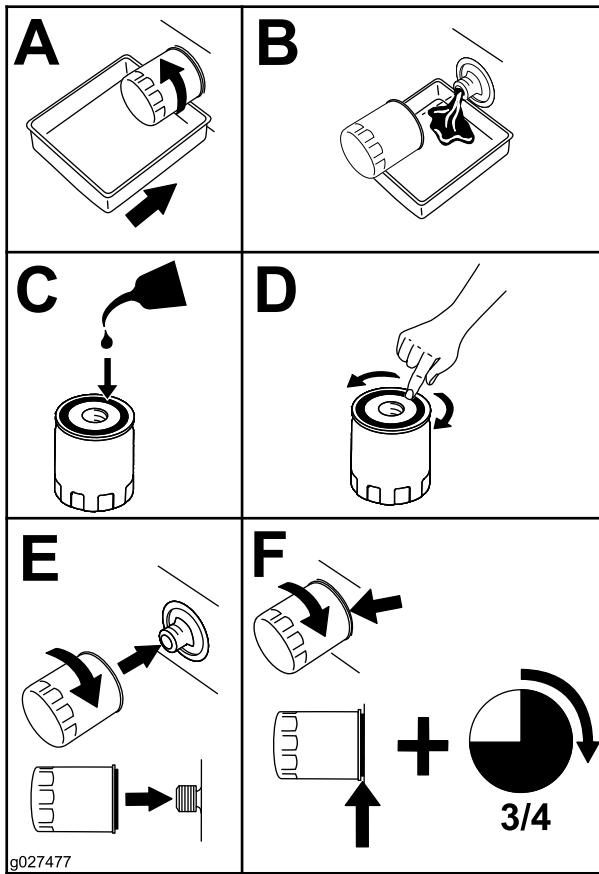

Figure 56

Note: Ensure that the oil-filter gasket touches the engine and then an extra 3/4 turn is completed.

3. Fill the crankcase with the proper type of new oil; refer to [Changing the Engine Oil \(page 40\)](#).

Servicing the Spark Plugs

Service Interval: Every 100 hours

Make sure that the air gap between the center electrode and the side electrode is correct before installing each spark plug. Use a spark-plug wrench for removing and installing the spark plugs and a gapping tool/feeler gauge to check and adjust the air gap. Install new spark plugs if necessary.

Type : NGK® BPR4ES or equivalent

Air Gap: 0.76 mm (0.030 inch)

Removing the Spark Plugs

Important: The fasteners on the covers of this machine are designed to remain on the cover after removal. Loosen all of the fasteners on each cover a few turns so that the cover is loose but still attached, then go back and loosen them until the cover comes free. This will prevent you from accidentally stripping the bolts free of the retainers.

1. Stop the engine, remove the key, and wait for all moving parts to stop before leaving the operating position.
2. Disengage the PTO, move the motion-control levers to the neutral-locked position, and set the parking brake.
3. Remove the hydraulic-unit shroud and the 2 bolts attached to it ([Figure 57](#)). This gives you access to the front spark plug.

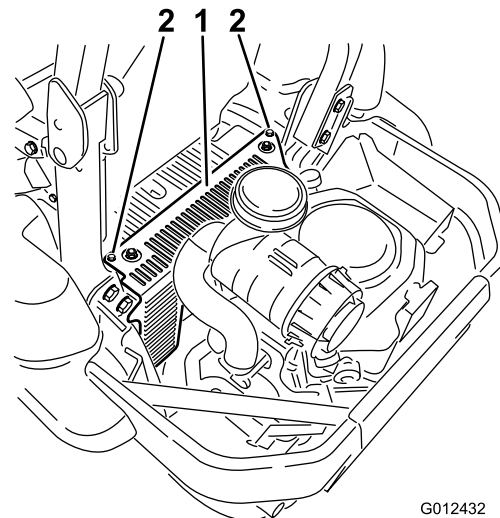

G012432

Figure 57

1. Hydraulic-unit shroud
2. Loosen these 2 bolts

4. Remove the spark plugs.

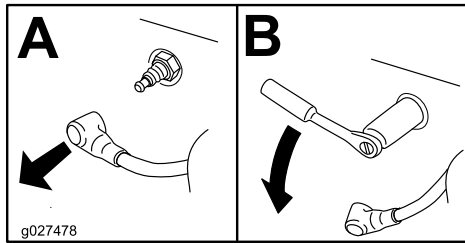
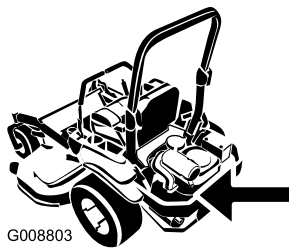

Figure 58

5. Install the left-hand hydraulic-unit shroud (Figure 57).

Checking the Spark Plugs

Important: Never clean the spark plug(s). Always replace the spark plug(s) when it has: a black coating, worn electrodes, an oily film, or cracks.

If you see light brown or gray on the insulator, the engine is operating properly. A black coating on the insulator usually means that the air cleaner is dirty.

Set the gap to 0.76 mm (0.030 inch).

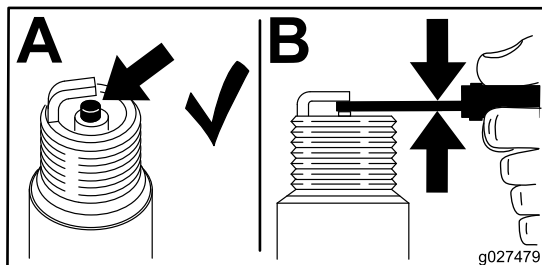

Figure 59

Installing the Spark Plugs

Tighten the spark plugs to 24.4 to 29.8 N-m (18 to 22 ft-lb).

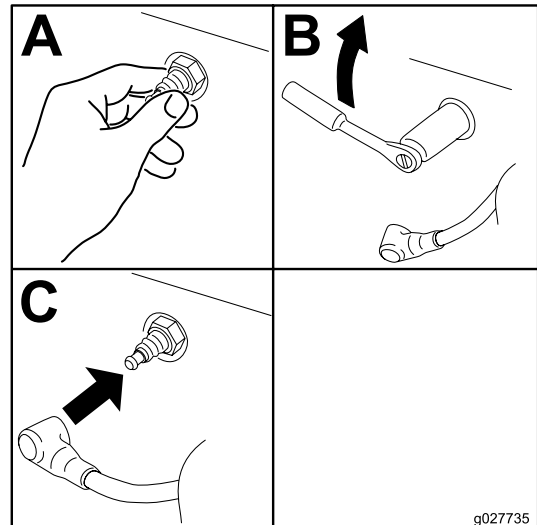

Figure 60

Checking the Spark Arrester (if equipped)

Service Interval: Every 50 hours

⚠ WARNING

Hot exhaust system components may ignite gasoline vapors even after the engine is stopped. Hot particles exhausted during engine operation may ignite flammable materials. Fire may result in personal injury or property damage.

Do not fuel or run the engine unless the spark arrester is installed.

1. Stop the engine, wait for all moving parts to stop, and remove the key. Engage the parking brake.
2. Wait for the muffler to cool.
3. If any breaks in the screen or welds are observed, replace the arrester.
4. If plugging of the screen is observed, remove the arrester and shake any loose particles out of the arrester, and clean the screen with a wire brush (soak it in solvent if necessary). Install the spark arrester on the exhaust outlet.

Fuel System Maintenance

Servicing the Fuel Tank

Do not attempt to drain the fuel tank. Ensure that an Authorized Service Dealer drains the fuel tank and services any components of the fuel system.

Replacing the Fuel Filter

Service Interval: Every 500 hours/Yearly (whichever comes first) (more often in dirty or dusty conditions).

The fuel filter is located near the engine on the front or rear side of the engine.

1. Disengage the PTO, move the motion-control levers to the neutral-locked position, and set the parking brake.
2. Stop the engine, remove the key, and wait for all moving parts to stop before leaving the operating position.
3. Allow the machine to cool down.
4. Stop the engine, remove the key, and wait for all moving parts to stop before leaving the operating position.
5. Close the fuel-shutoff valve under the seat (Figure 18).
6. Squeeze the ends of the hose clamps together and slide them away from the filter (Figure 61).

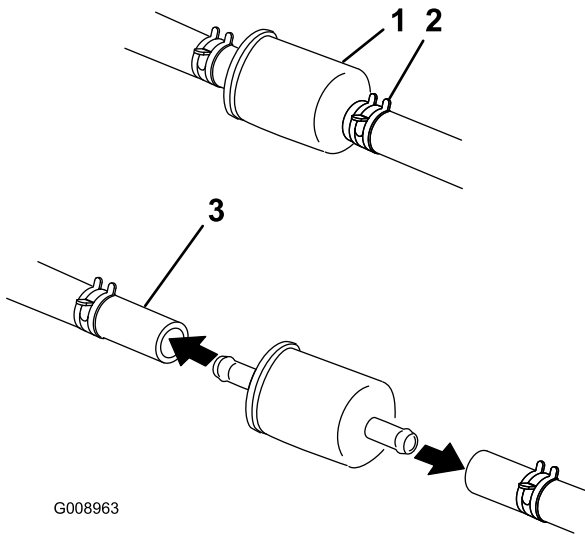

Figure 61

- | | |
|----------------|--------------|
| 1. Fuel filter | 3. Fuel line |
| 2. Hose clamp | |

-
7. Remove the filter from the fuel lines.
 8. Install a new filter and move the hose clamps close to the filter (Figure 61).
 9. Open the fuel-shutoff valve.

Note: It is important to install the fuel line hoses and secure them with plastic ties the same as they were originally installed at the factory to keep the fuel line away from components that could cause fuel line damage.

Electrical System Maintenance

Servicing the Battery

Service Interval: Monthly

WARNING

CALIFORNIA Proposition 65 Warning

Battery posts, terminals, and related accessories contain lead and lead compounds, chemicals known to the State of California to cause cancer and reproductive harm. Wash hands after handling.

⚠ DANGER

Battery electrolyte contains sulfuric acid which is a deadly poison and causes severe burns.

Do not drink electrolyte and avoid contact with skin, eyes, or clothing. Wear safety glasses to shield your eyes and rubber gloves to protect your hands.

Removing the Battery

⚠ WARNING

Battery terminals or metal tools could short against metal machine components causing sparks. Sparks can cause the battery gases to explode, resulting in personal injury.

- When removing or installing the battery, do not allow the battery terminals to touch any metal parts of the machine.
- Do not allow metal tools to short between the battery terminals and metal parts of the machine.

⚠ WARNING

Incorrect battery cable routing could damage the machine and cables causing sparks. Sparks can cause the battery gases to explode, resulting in personal injury.

- Always disconnect the negative (black) battery cable before disconnecting the positive (red) cable.
- Always connect the positive (red) battery cable before connecting the negative (black) cable.

1. Disengage the blade-control switch (PTO), move the motion-control levers to the neutral-locked position, and set the parking brake.
2. Stop the engine, remove the key, and wait for all moving parts to stop before leaving the operating position.
3. First disconnect the negative battery cable (black) from the negative (-)(black) battery terminal (Figure 62).
4. Slide the red terminal boot off the positive (red) battery terminal and remove the positive (+)(red) battery cable (Figure 62).
5. Remove the wing nut securing the battery clamp (Figure 62).
6. Remove the clamp (Figure 62).
7. Remove the battery.

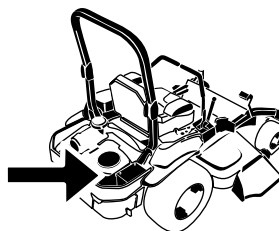

G008804

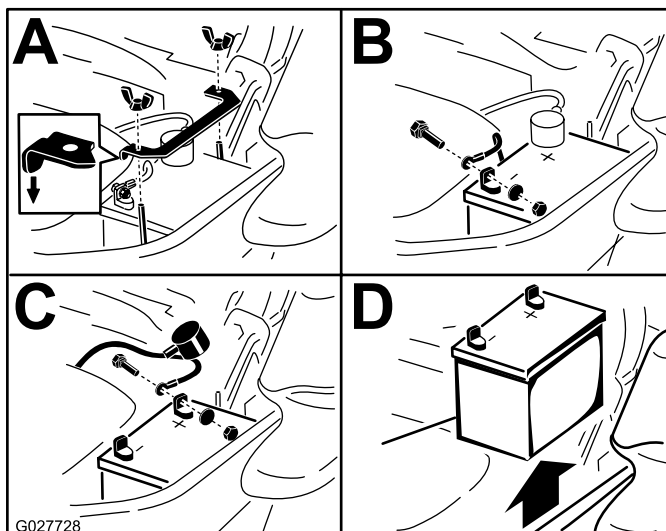

Figure 62

1. Remove the wing nut and clamp
2. Remove the negative battery cable before the positive
3. Remove the positive battery cable
4. Remove battery

Installing the Battery

1. Position battery in the tray with the terminal posts opposite from the hydraulic tank (Figure 62).
2. First, install the positive (red) battery cable to positive (+) battery terminal.
3. Then install the negative (black) battery cable and ground wire to the negative (-) battery terminal.

4. Secure the cables with 2 bolts, 2 washers, and 2 locknuts (Figure 62).
5. Slide the red terminal boot onto the positive (red) battery post.
6. Install the clamp and secure it with the wing nut (Figure 62).

Charging the Battery

⚠ WARNING

Charging the battery produces gases that can explode.

Never smoke near the battery and keep sparks and flames away from the battery.

Important: Always keep the battery fully charged (1.265 specific gravity). This is especially important to prevent battery damage when the temperature is below 0°C (32°F).

1. Charge battery for 10 to 15 minutes at 25 to 30 amps or 30 minutes at 10 amps.
2. When the battery is fully charged, unplug the charger from the electrical outlet, then disconnect the charger leads from the battery posts (Figure 63).
3. Install the battery in the machine and connect the battery cables, refer to [Installing the Battery](#) (page 44).

Note: Do not run the machine with the battery disconnected, electrical damage may occur.

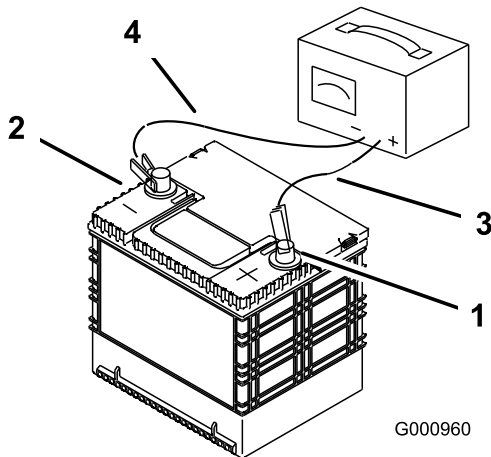

Figure 63

1. Positive battery post
2. Negative battery post
3. Red (+) charger lead
4. Black (-) charger lead

Servicing the Fuses

The electrical system is protected by fuses. It requires no maintenance, however, if a fuse blows check the component/circuit for a malfunction or short.

1. The fuses are located on right hand console next to the seat (Figure 64).
2. To replace the fuses, pull out on the fuse to remove it.
3. Install a new fuse (Figure 64).

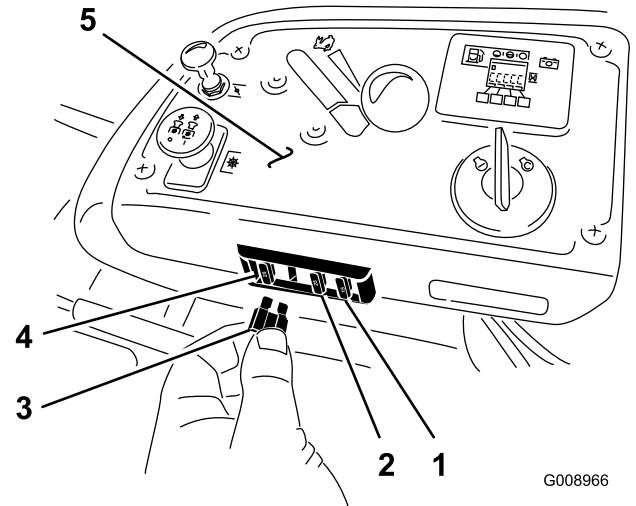

Figure 64

1. Optional accessory—15 amp
2. Charge—25amp
3. PTO—10amp
4. Main—25amp
5. Console

Drive System Maintenance

Checking the Seat Belt

Service Interval: Before each use or daily

Visually inspect seat belt for wear, cuts, and proper operation of retractor and buckle. Replace before operating if damaged.

Checking the Rollover Protection System (ROPS) Knobs

Service Interval: Before each use or daily

Check that both the mounting hardware and the knobs are in good working condition. Make sure that the knobs are fully engaged with the ROPS in the fully raised position. The upper hoop of the roll bar may need to be pushed forward or pulled rearward to get both knobs fully engaged.

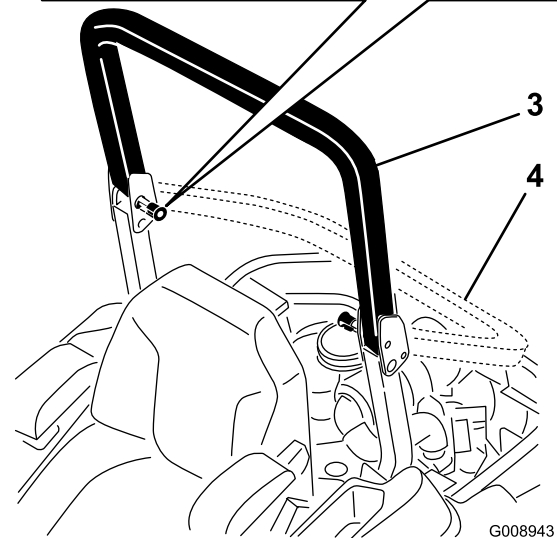
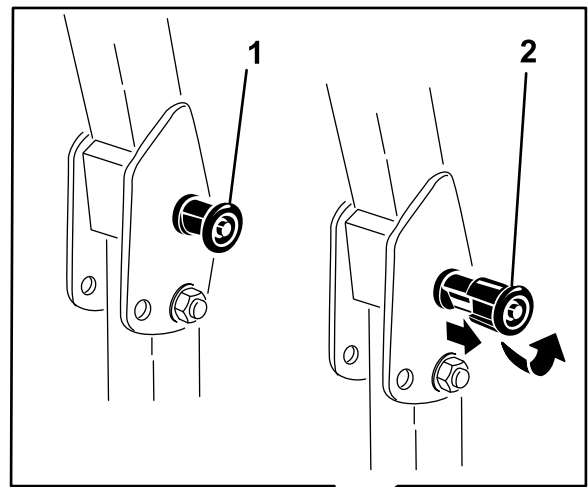

Figure 65

- | | |
|---|-------------------------------------|
| 1. ROPS knob (locked position) | 3. Roll bar in the upright position |
| 2. Pull ROPS knob out and rotate 90 degrees to change roll bar position | 4. Roll bar in the folded position |

Adjusting the Tracking

1. Disengage the blade-control switch (PTO).
2. Drive to an open flat area, move the motion-control levers to the neutral-locked position.
3. Move the throttle midway between fast and slow.
4. Move both motion-control levers all the way forward until they both hit the stops in the T-slot.
5. Check which way the machine tracks.
6. If it tracks to the right, loosen the bolts and adjust the left stop plate on the left T-slot until the machine tracks straight.
7. If it tracks to the left, loosen the bolts and adjust the right stop plate on the right T-slot until the machine tracks straight.
8. Tighten the stop plate.

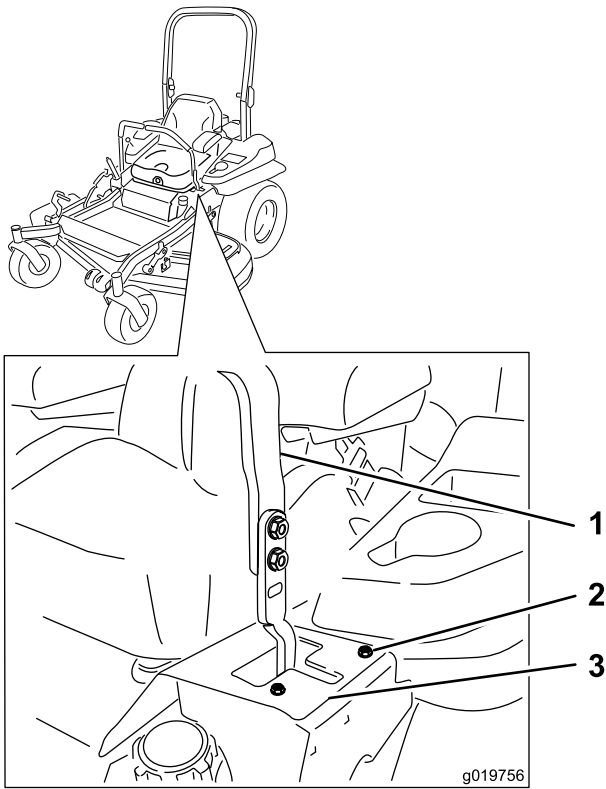

Figure 66

Left control lever shown

- | | |
|------------------|---------------|
| 1. Control lever | 3. Stop plate |
| 2. Bolt | |

Checking the Tire Pressure

Service Interval: Every 50 hours/Monthly (whichever comes first)

Maintain the air pressure in the rear tires at 90 kPa (13 psi). Uneven tire pressure can cause uneven cut. Check the tires when they are cold to get the most accurate pressure reading.

Note: The front tires are semi-pneumatic tires and do not require air pressure maintenance.

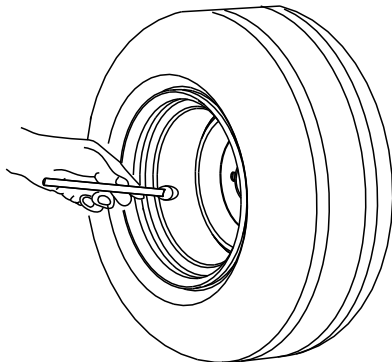

Figure 67

Checking the Wheel Lug Nuts

Service Interval: After the first 100 hours

Every 500 hours

Check and torque the wheel lug nuts to 122 to 129 N-m (90 to 95 ft-lb).

Checking the Wheel Hub Slotted Nut

Service Interval: After the first 100 hours

Every 500 hours

Check and ensure that the torque of the slotted nut is 286 to 352 N-m (211 to 260 ft-lb).

Note: Do not use anti-seize on wheel hub.

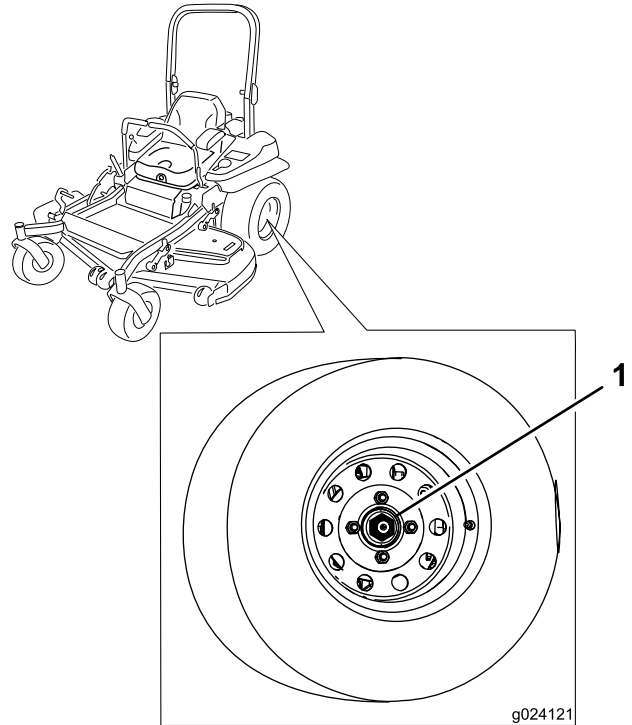

Figure 68

1. Slotted nut

Adjusting the Caster Pivot Bearing

Service Interval: Every 500 hours/Yearly (whichever comes first)

1. Disengage the blade-control switch (PTO), move the motion-control levers to the neutral-locked position, and set the parking brake.
2. Stop the engine, remove the key, and wait for all moving parts to stop before leaving the operating position.
3. Remove the dust cap from the caster and tighten the locknut (Figure 69).

- Tighten the locknut until the spring washers are flat and then back off a 1/4 turn to properly set the pre-load on the bearings (Figure 69).

Important: Make sure that the spring washers are installed correctly as shown in Figure 69.

- Install the dust cap (Figure 69).

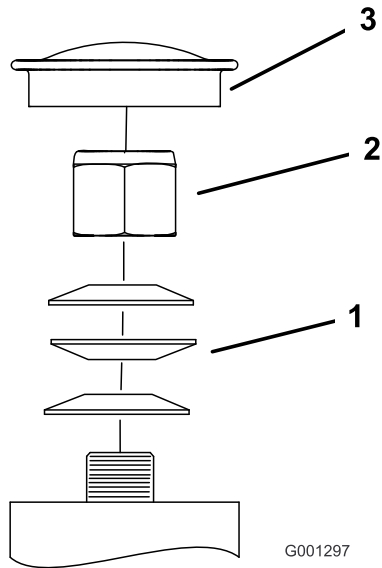

Figure 69

- | | |
|-------------------|-------------|
| 1. Spring washers | 3. Dust cap |
| 2. Locknut | |

Cooling System Maintenance

Cleaning the Engine Screen and the Engine-Oil Cooler

Service Interval: Before each use or daily—Clean the engine screen.

Before each use or daily—Clean the oil cooler (model 74925TE only).

Before each use remove any buildup of grass, dirt, or other debris from the engine screen. This will help ensure adequate cooling and correct engine speed and will reduce the possibility of overheating and mechanical damage to the engine (Figure 71).

Remove any buildup of grass, dirt, or other debris from the oil cooler (model 74925TE only); refer to Figure 70.

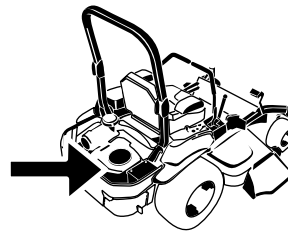

G010168

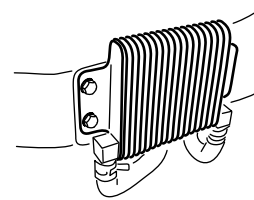

G009191

Figure 70

Cleaning the Engine Cooling Fins and Shrouds

Service Interval: Every 100 hours/Yearly (whichever comes first)

- Disengage the PTO and set the parking brake.
- Stop the engine, remove the key, and wait for all moving parts to stop before leaving the operating position.
- Remove the air intake screen, recoil starter and fan housing (Figure 71).
- Clean the debris and grass from the engine parts.
- Install air intake screen, recoil starter and fan housing (Figure 71).

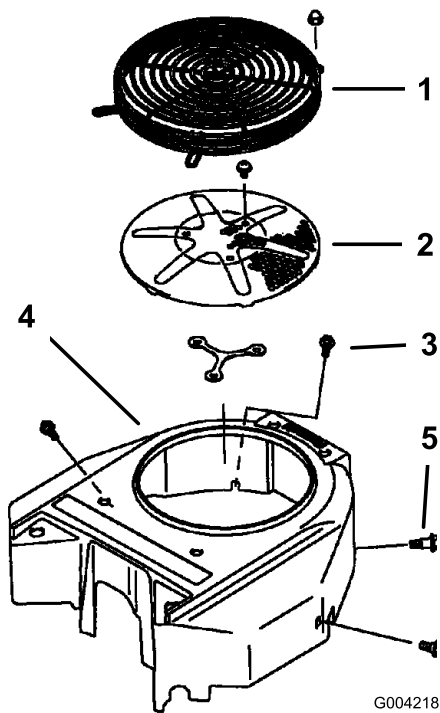

Figure 71

- | | |
|-----------------------------|----------------|
| 1. Engine guard | 4. Fan housing |
| 2. Engine air intake screen | 5. Screw |
| 3. Bolt | |

Checking and Cleaning the Hydraulic-Unit Shrouds

Service Interval: Before each use or daily

Important: The fasteners on the covers of this machine are designed to remain on the cover after removal. Loosen all of the fasteners on each cover a few turns so that the cover is loose but still attached, then go back and loosen them until the cover comes free. This will prevent you from accidentally stripping the bolts free of the retainers.

1. Disengage the PTO and set the parking brake.
2. Stop the engine, remove the key, and wait for all moving parts to stop before leaving the operating position.
3. Move the seat all the way forward.
4. Allow the engine and the hydraulic system to cool.
5. Clean the debris and grass from the hydraulic-unit shrouds (Figure 72).

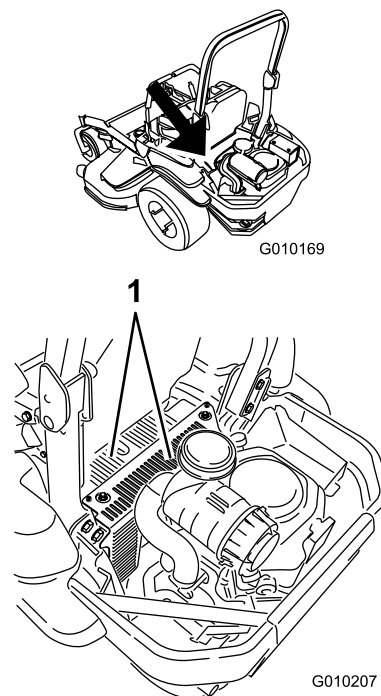

Figure 72

1. Hydraulic-unit shrouds

6. Over each dipstick, remove the cover and the bolt attached to the cover. Clean around each dipstick and hydraulic unit (Figure 73).
7. Install the cover over each dipstick.
8. Adjust the seat.

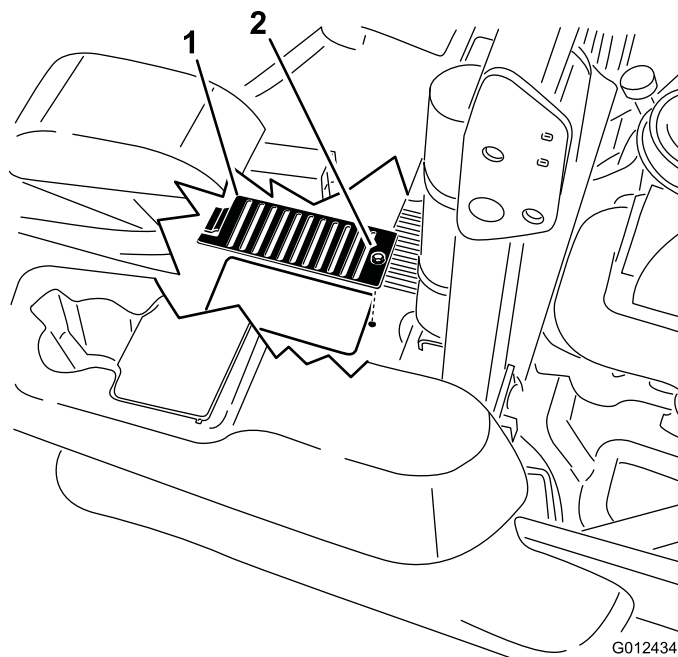

Figure 73

- | | |
|----------|---------|
| 1. Cover | 2. Bolt |
|----------|---------|

Brake Maintenance

Adjusting the Parking Brake

Service Interval: After the first 100 hours

Every 500 hours thereafter

Check to make sure the brake is adjusted properly before adjusting.

Note: This procedure must be followed after the first 100 hours or when a brake component has been removed or replaced.

1. Drive the machine onto a level surface.
2. Disengage the blade-control switch (PTO), move the motion-control levers to the neutral locked position and engage the parking brake.
3. Stop the engine, wait for all moving parts to stop, and remove the key.
4. Raise the back of the machine up and support the machine with jack stands.

⚠ DANGER

Mechanical or hydraulic jacks may fail to support machine and cause a serious injury.

- Use jack stand when supporting machine.
- Do not use hydraulic jacks.

5. Remove the rear tires from the machine.
6. Remove any debris from the brake area.
7. Rotate the drive wheel release handle to the released position. Refer to [Using the Drive-Wheel Release Valves \(page 28\)](#).
8. Check to see if there is a visible gap between the L-bracket and the linkage stop ([Figure 74](#)).

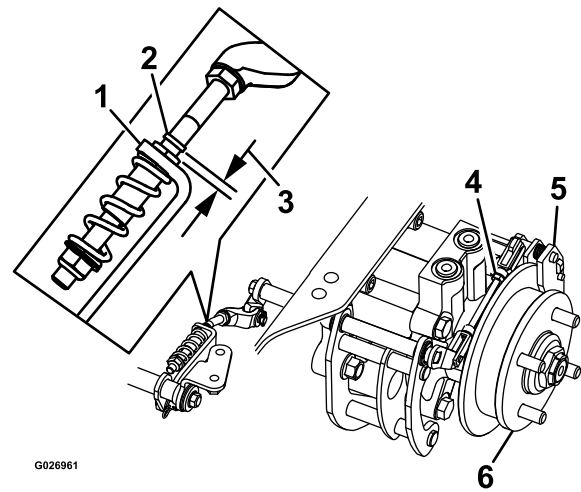

Figure 74
Left Side Shown

1. L-bracket
 2. Linkage stop
 3. Gap
 4. Rear linkage assembly
 5. Caliper
 6. Wheel hub
-
9. Disengage the parking brake, the lever should be in the down position.
 10. Turn the wheel hub by hand in both directions relative to the caliper; the wheel hub should move freely between the caliper.
 11. If a gap is needed or the wheel hub does not move freely:
 - A. Disengage the parking brake.
 - B. Disconnect and fine-tune the rear linkage assembly:
 - Shorten the link to create a gap.
 - Lengthen the link to allow wheel hub movement.
 - C. Reconnect the rear linkage assembly.
 12. Engage the parking brake and check the gap.
 13. Repeat steps 9 through 13 until a visible gap is achieved and the wheel hub rotates freely.
 14. Repeat this procedure for the brake on the opposite side.
 15. Rotate the drive wheel release handle to the operating position. Refer to [Using the Drive-Wheel Release Valves \(page 28\)](#).
 16. Install the rear tires and torque the lug nuts. Refer to [Checking the Wheel Lug Nuts \(page 47\)](#).
 17. Remove the jack stands.

Belt Maintenance

Inspecting the Belts

Service Interval: Every 50 hours

Check the belts for squealing when the belt is rotating, blades slipping when cutting grass, frayed belt edges, burn marks and cracks are signs of a worn mower belt. Replace the mower belt if any of these conditions are evident.

Replacing the Mower Belt

Squealing when the belt is rotating, blades slipping when cutting grass, frayed belt edges, burn marks, and cracks are signs of a worn mower belt. Replace the mower belt if any of these conditions are evident.

Important: The fasteners on the covers of this machine are designed to remain on the cover after removal. Loosen all of the fasteners on each cover a few turns so that the cover is loose but still attached, then go back and loosen them until the cover comes free. This will prevent you from accidentally stripping the bolts free of the retainers.

1. Disengage the PTO, move the motion-control levers to the neutral-locked position and set the parking brake.
2. Stop the engine, remove the key, and wait for all moving parts to stop before leaving the operating position.
3. Lower the mower to the 76 mm (3 inch) height of cut.
4. Loosen the bottom bolt holding the mower-deck curtain to the mower deck. Refer to [Releasing the Mower-Deck Curtain](#) (page 35).
5. Remove the sheet metal guard. Refer to [Removing the Sheet-Metal Guard](#) (page 35)
6. Remove the belt covers and the bolts attached to them ([Figure 75](#)).

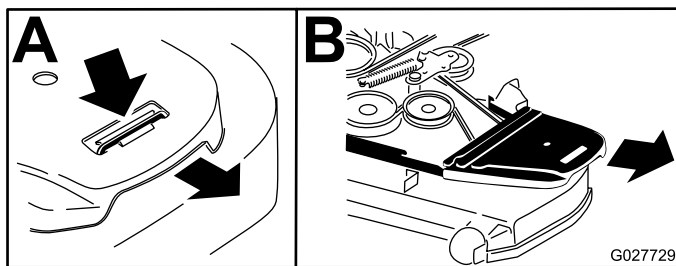

Figure 75

1. Loosen the bolt
2. Remove belt cover

7. Use a ratchet in the square hole in the idler arm to remove tension on the idler spring ([Figure 76](#)).
8. Remove the belt from the mower deck pulleys.
9. Remove the belt guide on the spring loaded idler arm shown in [Figure 76](#).

10. Remove the existing belt.
11. Install the new belt around the mower pulleys and the clutch pulley under the engine ([Figure 76](#)).

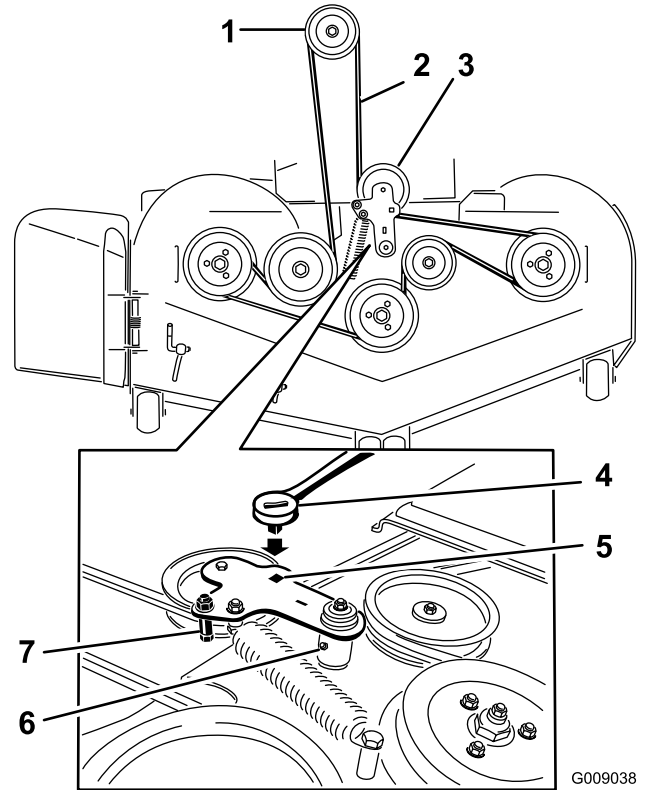

Figure 76

- | | |
|-------------------------------|---|
| 1. Clutch pulley | 5. Square hole in the idler arm for the ratchet |
| 2. Mower belt | 6. Idler grease fitting |
| 3. Spring loaded idler pulley | 7. Belt guide |
| 4. Ratchet | |

12. Install the belt guide on the idler arm shown in [Figure 76](#).
13. Using the ratchet in the square hole, install the idler spring ([Figure 76](#)).
Make sure that the spring ends are seated in the anchor grooves.
14. Install the belt covers and the bolts attached to them ([Figure 77](#)).

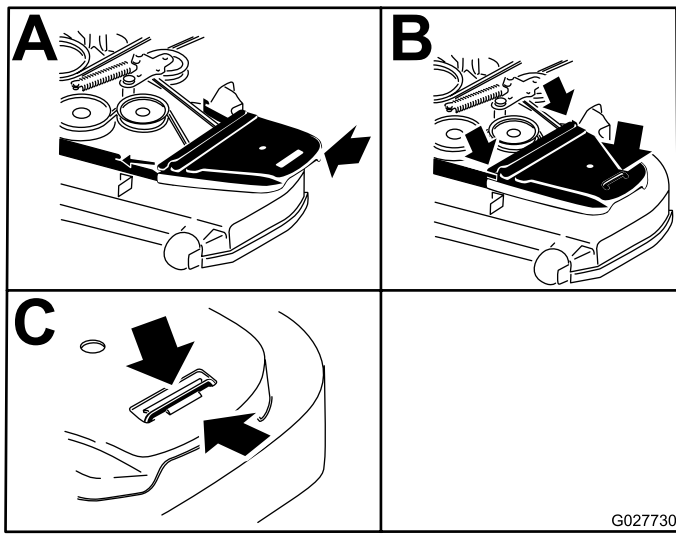

Figure 77

1. Position the belt cover
2. Slide belt cover under the side catches
3. Tighten the bolt

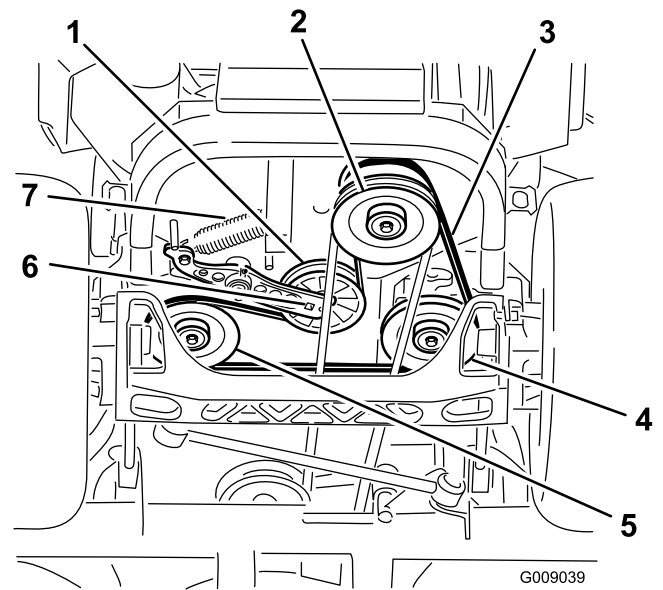

Figure 78

1. Idler pulley
2. Clutch pulley
3. Pump drive belt
4. Right-hand hydraulic-pump pulley
5. Left-hand hydraulic-pump pulley
6. Square hole in idler arm
7. Idler spring

Replacing the Hydraulic-Pump Drive Belt

1. Disengage the PTO and set the parking brake.
2. Stop the engine, remove the key, and wait for all moving parts to stop before leaving the operating position.
3. Remove mower belt. Refer to [Replacing the Mower Belt \(page 51\)](#).
4. Raise the machine and support it with jack stands ([Figure 78](#)).
5. Use a ratchet in the square hole in the idler arm to remove the idler spring ([Figure 78](#)).
6. Unhook the idler spring from the frame ([Figure 78](#)).
7. Remove the belt from the hydraulic-unit drive pulleys and the engine pulley
8. Install the new belt around the engine pulley and the 2 drive pulleys.
9. Using a ratchet in the square hole in the idler arm, install the idler spring to the frame ([Figure 78](#)).
10. Install the mower belt. Refer to [Replacing the Mower Belt \(page 51\)](#).

Controls System Maintenance

Adjusting the Control Handle Position

There are 2 height positions for the control levers; high and low. Remove the bolts to adjust the height for the operator.

1. Disengage the PTO, move the motion-control levers to the neutral-locked position, and set the parking brake.
2. Stop the engine, remove the key, and wait for all moving parts to stop before leaving the operating position.
3. Loosen the bolts and flange nuts installed in the levers ([Figure 79](#)).
4. Align the levers front to rear position by bring the levers together to the neutral position and slide them until they are aligned, then tighten the bolts ([Figure 80](#)).

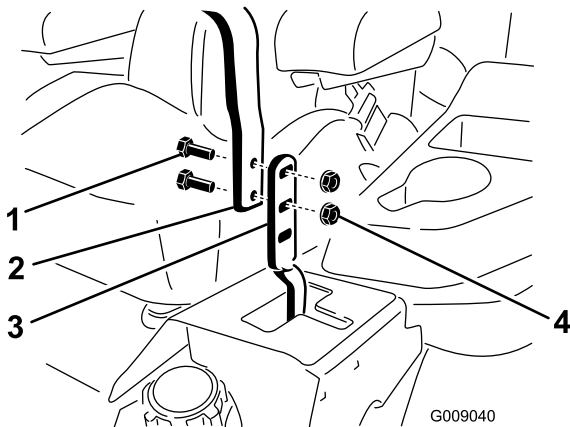

Figure 79

- | | |
|-----------|------------------|
| 1. Bolt | 3. Control lever |
| 2. Handle | 4. Nut |

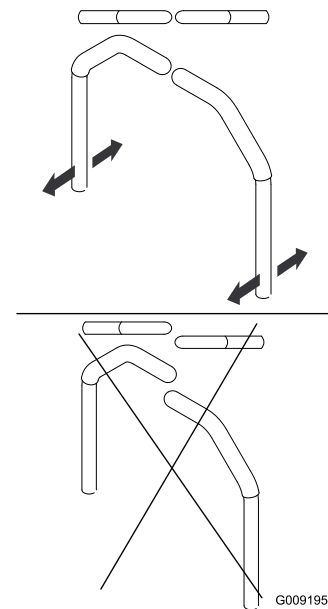

Figure 80

5. If the ends of the levers hit against each other, refer to [Adjusting the Motion-Control Neutral-Lock Pivot](#) ([page 54](#)). Repeat to adjust the control levers.

Adjusting the Motion-Control Linkage

Located on either side of the fuel tank, below the seat are the pump control linkages. Rotating the pump linkage with a 1/2 inch wrench allows fine-tuning adjustments so that the machine does not move in neutral. Any adjustments should be made for neutral positioning only.

⚠ WARNING

The engine must be running and the drive wheels must be turning so that the motion-control adjustment can be performed. Contact with moving parts or hot surfaces may cause personal injury.

Keep fingers, hands, and clothing clear of rotating components and hot surfaces.

1. Prior to starting the engine, push the deck-lift pedal and remove the height-of-cut pin. Lower the deck to the ground.
2. Raise the rear of machine up and support it with jack stands (or equivalent support) just high enough to allow the drive wheels to turn freely.
3. Remove the electrical connection from the seat safety switch, located under the bottom cushion of the seat.
Note: The switch is a part of the seat assembly.
4. **Temporarily** install a jumper wire across the terminals in the connector of the main wiring harness.
5. Start the engine.

Note: The brake must be engaged and the motion-control levers must be out to start the engine. The operator does not have to be in the seat because of the jumper wire being used. Run the engine at full throttle and release the brake.

- Run the machine at least 5 minutes with the motion-control levers at full forward speed to bring the hydraulic oil up to operating temperature.

Note: The motion-control lever needs to be in neutral while making any necessary adjustments.

- Bring the motion-control levers into the neutral position.
- Adjust the pump control rod lengths by rotating the double nuts on the rod in the appropriate direction until the wheels slightly creep in reverse (Figure 81).

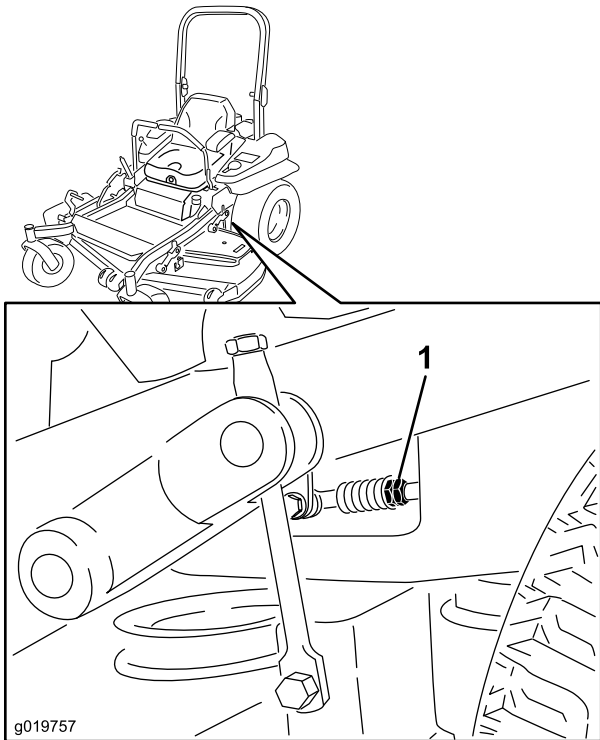

Figure 81

- Double nuts

- Move the motion-control levers to the reverse position, and while applying slight pressure to the lever, allow the reverse indicator springs to bring the levers back to neutral.

Note: The wheels must stop turning or slightly creep in reverse.

- Shut off the machine. Remove the jumper wire from wire harness and plug the connector into the seat switch.
- Remove the jack stands.
- Raise the deck and install the height-of-cut pin.
- Check that the machine does not creep in neutral with the park brakes disengaged.

Adjusting the Motion-Control Damper

The top damper mounting bolt can be adjusted to obtain a more desired motion-control lever resistance. See Figure 82 for mounting options.

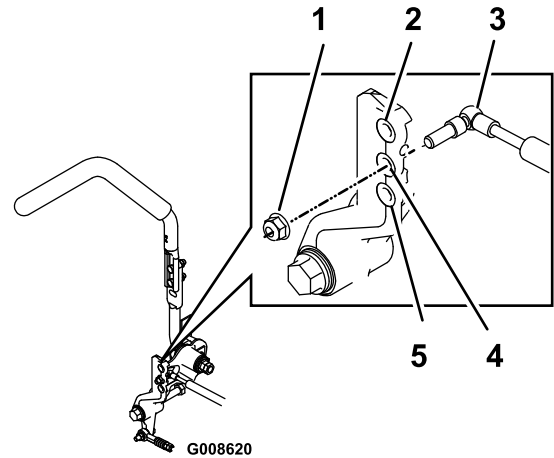

Figure 82

Right-hand motion control shown

- Torque the locknut to 23 N-m (17 ft-lb). The bolt must protrude past the end of the locknut after torquing.
- Most resistance (firmest feel)
- Damper
- Medium resistance (medium feel)
- Least resistance (softest feel)

Adjusting the Motion-Control Neutral-Lock Pivot

The flanged nut can be adjusted to obtain a more desired motion-control lever resistance when moving it to the neutral-lock position. See Figure 83 for adjustment options.

- Loosen the jam nut.
- Tighten or loosen the flanged nut to the desired feel.
For more resistance, tighten the flanged nut.
For less resistance, loosen the flanged nut
- Tighten the jam nut.

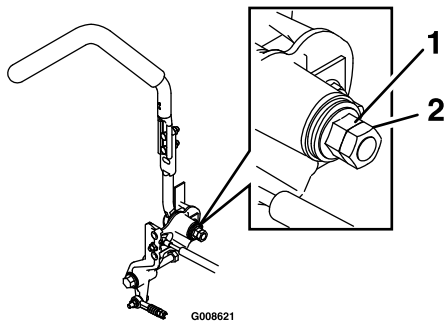

Figure 83

1. Flanged nut

2. Jam nut

Hydraulic System Maintenance

Servicing the Hydraulic System

Hydraulic Oil Type: Toro® HYPR-OIL™ 500 hydraulic oil or Mobil® 1 15W-50.

Important: Use oil specified. Other fluids could cause system damage.

Each Hydraulic System Oil Capacity: 1.5 L (1.59 US qt) per side with filter change

Checking the Hydraulic Oil

Service Interval: Every 50 hours—Check the hydraulic oil level.

1. Position the machine on a level surface.
2. Disengage the PTO, move the motion-control levers to the neutral-locked position, and set the parking brake.
3. Stop the engine, remove the key, and wait for all moving parts to stop before leaving the operating position.
4. Allow the engine and hydraulic system to cool for 10 minutes.

Note: The oil level on the dipstick will be incorrect if the oil is checked when the machine is hot.

5. Move the seat forward.
6. Clean the area around the dipsticks of the hydraulic system reservoirs (Figure 84).
7. Remove one dipstick from the hydraulic reservoir (Figure 84).
8. Wipe the dipstick off and thread the dipstick into the reservoir.
9. Remove the dipstick and look at the end (Figure 84).

Note: If the oil level is at the add mark, slowly pour only enough oil into the hydraulic reservoir to raise the level to the full or **H** line.

Important: Do not overfill the hydraulic units with oil as damage may occur. Do not run the machine with the oil below the add mark.

10. Install the dipstick.
11. Repeat procedure for the opposite dipstick.

Replacing the Hydraulic Filters and Hydraulic Oil

Service Interval: After the first 250 hours—Change the hydraulic filters and hydraulic oil when using any type of oil.

Every 250 hours—Change the hydraulic filters and hydraulic oil when using Mobil® 1 oil (more often in dirty or dusty conditions).

Every 500 hours—Change the hydraulic filters and hydraulic oil when using Toro® HYPR-OIL™ 500 hydraulic oil (more often in dirty or dusty conditions).

To replace the hydraulic oil, remove the filters. Replace both at the same time. Refer to the oil specifications under [Servicing the Hydraulic System \(page 55\)](#) for the correct oil.

1. Disengage the blade-control switch (PTO), move the motion-control levers to the neutral-locked position, and set the parking brake.
2. Stop the engine, remove the key, and wait for all moving parts to stop before leaving the operating position.
3. Raise the machine and support it with jack stands ([Figure 85](#)).

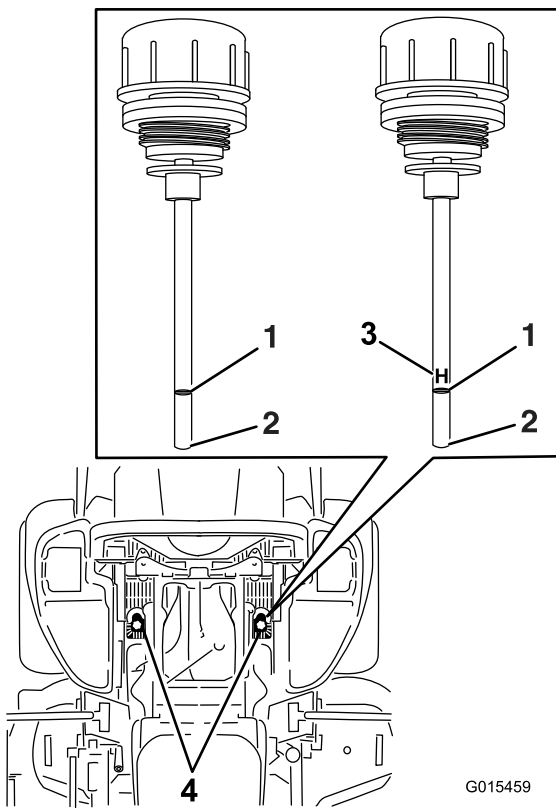

Figure 84

Either dipstick will be used in the machine

- | | |
|---------|----------------------------------|
| 1. Full | 3. H—means high level |
| 2. Add | 4. Dipstick locations under seat |

⚠ WARNING

Hydraulic oil escaping under pressure can penetrate skin and cause injury.

- If hydraulic oil is injected into the skin it must be surgically removed within a few hours by a doctor familiar with this type of injury. Gangrene may result if this is not done.
- Keep body and hands away from pin hole leaks or nozzles that eject high pressure hydraulic oil.
- Use cardboard or paper to find hydraulic leaks.
- Safely relieve all pressure in the hydraulic system before performing any work on the hydraulic system.
- Make sure that all hydraulic oil hoses and lines are in good condition and that all hydraulic connections and fittings are tight before applying pressure to the hydraulic system.

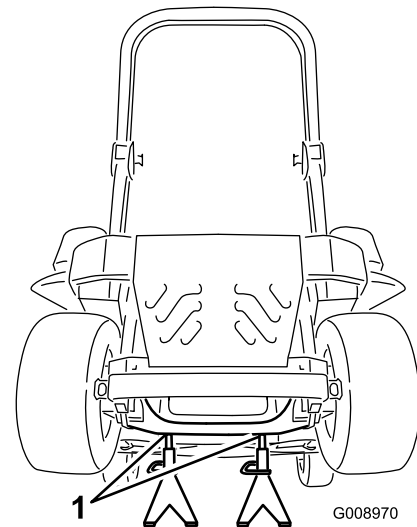

Figure 85

1. Jack stands

4. Remove both the mower belt and the pump drive belt.

Note: This will prevent oil from getting on the belts. Refer to [Belt Maintenance \(page 51\)](#).

5. Place a drain pan under the filter, remove the old filter, and wipe the surface clean ([Figure 86](#)).

Mower Deck Maintenance

Leveling the Mower Deck

Setting up the Machine

Note: Ensure the mower deck is leveled before matching the height of cut (HOC).

1. Position mower on a flat surface.
2. Disengage the blade-control switch (PTO), move the motion-control levers to the neutral-locked position, and set the parking brake.
3. Stop the engine, remove the key, and wait for all moving parts to stop before leaving the operating position.
4. Check tire pressure of the drive tires. If needed, adjust it to 90 kPa (13 psi).
5. Position the mower to the 76 mm (3 inch) height-of-cut position.

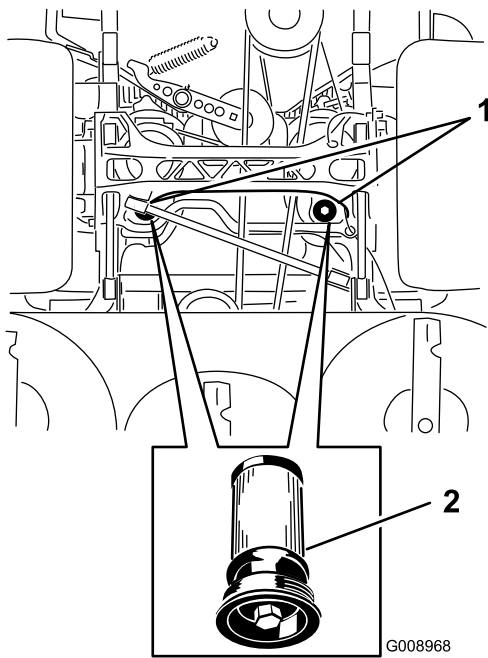

Figure 86

Bottom view of machine

1. Filter locations
2. Hydraulic filter

6. Apply a thin coat of hydraulic oil to the rubber gasket on the replacement filter (Figure 86).
7. Install the replacement hydraulic filter.
8. Install the pump drive belt and the mower belt.
9. Remove the jack stands and lower the machine (Figure 85).
10. Add oil to the hydraulic reservoir and check for any leaks.
11. Clean up any spilled oil.
12. Start the engine and let it run for about 2 minutes to purge air from the system.
13. Stop the engine and check for leaks.
14. Check the oil level while the oil is cold.
15. If required, add oil to the hydraulic reservoir.

Note: Do not overfill the reservoir.

Deck Leveling

1. Position the mower on a flat surface.
2. Stop engine, wait for all moving parts to stop, and remove key. Engage parking brake.
3. Check the tire pressure in the drive tires. Proper inflation pressure for tires is 90 kPa (13 psi). Adjust it if necessary.
4. Position the transport lock in to the latching position.
5. Push the deck-lift pedal all the way forward and the deck will latch at the 14 cm (5-1/2 inch) transport position (Figure 87).

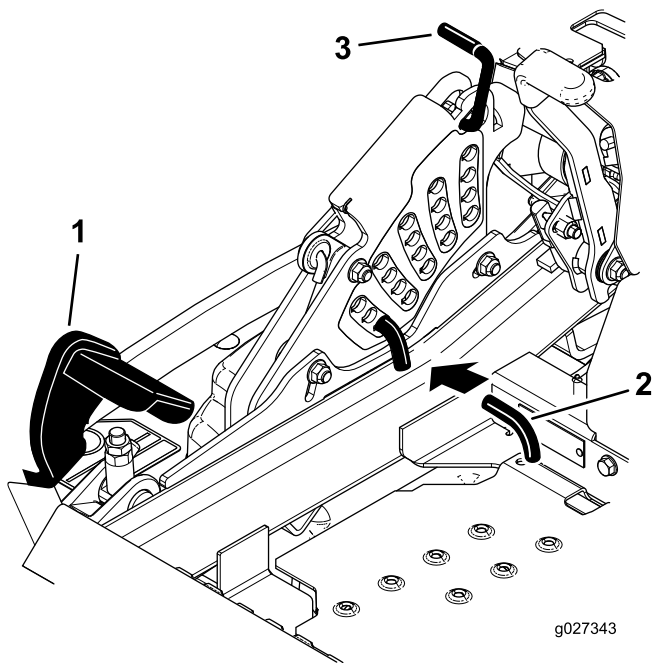

Figure 87

- 1. Deck-lift pedal
- 2. Height-of-cut pin
- 3. Transport lock

- 10. Fine-tune the adjustment nut on the front deck lift assembly by turning it (Figure 89).

Note: To increase the height, turn the adjustment nut clockwise; to decrease the height, turn the nut counterclockwise.

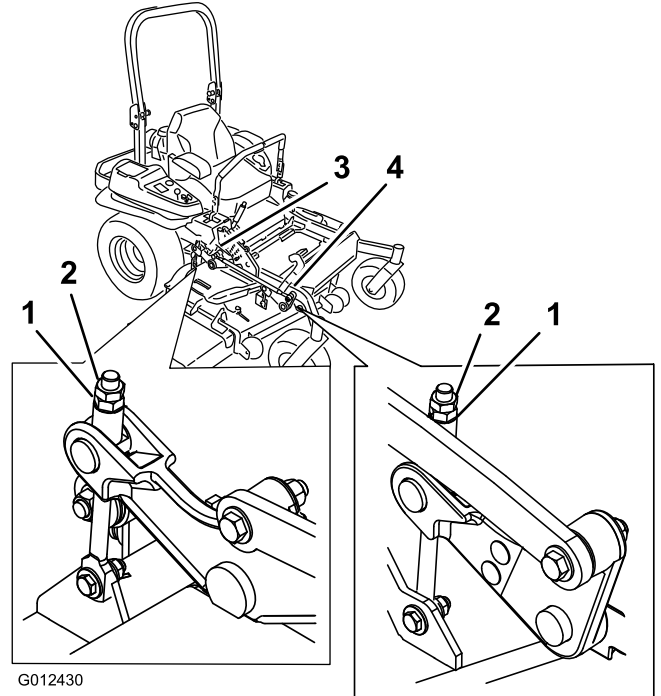

Figure 89

- 1. Adjustment nut
- 2. Jam nut
- 3. Rear deck adjustment
- 4. Front deck adjustment

- 6. Insert the height adjustment pin into the 7.6 cm (3 inch) cutting-height location.
- 7. Release the transport lock and allow the deck to lower to the cutting height.
- 8. Raise the discharge chute.
- 9. On both sides of the deck, measure from the level surface to the front tip of the blade (Position A).

Note: The measurement should read 7.6 mm (3 inches); refer to Figure 88.

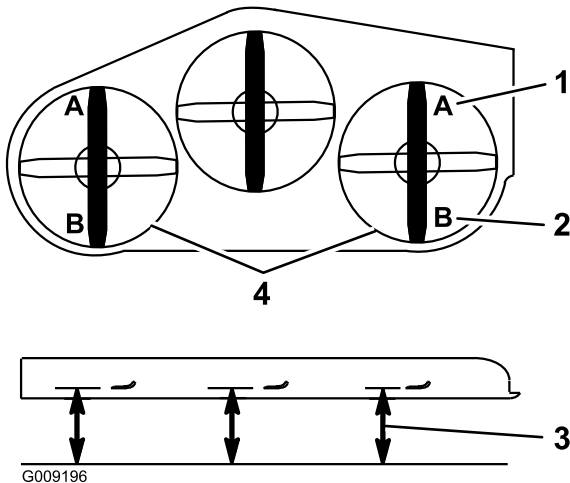

Figure 88

- 1. 7.6 cm (3 inches) at A is correct
- 2. 8.3 cm (3-1/4 inches) at B is correct
- 3. Measure here from the blade tip to hard surface
- 4. Measure at A and B on both sides

- 11. If the front deck links do not have enough adjustment to achieve accurate cut height, the single point adjustment can be utilized to gain more adjustment.
- 12. To adjust the single point system, loosen the 2 bolts at the bottom of the height-of-cut plate. Refer to Figure 90.

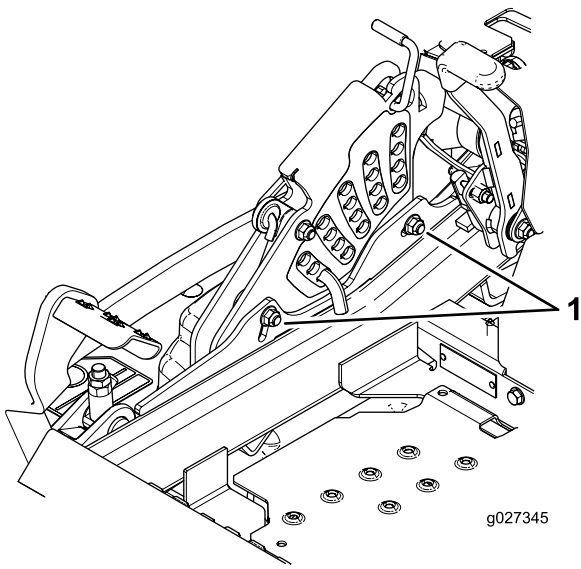

Figure 90

1. Bolts at the bottom of the height-of-cut plate

13. If the deck is too low, tighten the single point adjustment bolt by rotating it clockwise. If the deck is too high, loosen the single point adjustment bolt by rotating it counterclockwise (Figure 91).

Note: Loosen or tighten the single point adjustment bolt enough to move the height-of-cut plate mounting bolts at least 1/3 the length of the available travel in their slots. This will regain some up and down adjustment on each of the four deck links.

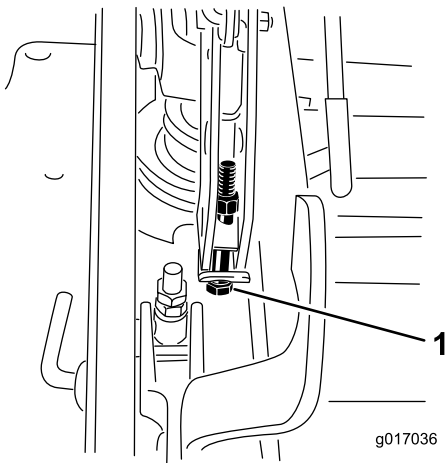

Figure 91

1. Single point adjustment bolt

14. Tighten the 2 bolts at the bottom of the height of cut plate (Figure 90). Torque to 37 to 45 N-m (27 to 33 ft-lb).

Note: In most conditions, the back blade tip should be adjusted 6.4 mm (1/4 inch) higher than the front.

15. On both sides of the deck, measure from the level surface to the back tip of the blade (Position B). The

measurement should read 8.3 cm (3-1/4 inches); refer to Figure 88.

16. Fine-tune the adjustment nut on the front deck lift assembly by turning it (Figure 89).
To increase the height, turn the adjustment nut clockwise; to decrease, turn counterclockwise.
17. Measure until all four sides are the correct height. Tighten all the jam nuts on the deck lift arm assemblies.
18. Lower discharge chute.

Servicing the Cutting Blades

Maintain sharp blades throughout the cutting season because sharp blades cut cleanly without tearing or shredding the grass blades. Tearing and shredding turns grass brown at the edges, which slows growth and increases the chance of disease.

Check the cutter blades daily for sharpness, and for any wear or damage. File down any nicks and sharpen the blades as necessary. If a blade is damaged or worn, replace it immediately with a genuine Toro replacement blade. For convenient sharpening and replacement, you may want to keep extra blades on hand.

⚠ DANGER

A worn or damaged blade can break, and a piece of the blade could be thrown into the operator's or bystander's area, resulting in serious personal injury or death.

- Inspect the blade periodically for wear or damage.
- Replace a worn or damaged blade.

Before Inspecting or Servicing the Blades

Park the machine on a level surface, disengage the blade-control switch (PTO), and set the parking brake. Turn the ignition key to the off position. Remove the key.

Inspecting the Blades

Service Interval: Before each use or daily

1. Inspect the cutting edges (Figure 92). If the edges are not sharp or have nicks, remove and sharpen the blades. Refer to [Sharpening the Blades](#) (page 61).
2. Inspect the blades, especially the curved area (Figure 92). If you notice any damage, wear, or a slot forming in this area (Figure 92), immediately install a new blade.

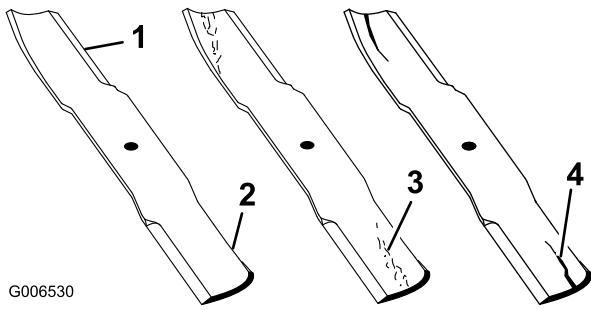

Figure 92

- | | |
|-----------------|----------------------|
| 1. Cutting edge | 3. Wear/slot forming |
| 2. Curved area | 4. Crack |

Removing the Blades (page 60) and Installing the Blades (page 61).

▲ WARNING

A blade that is bent or damaged could break apart and could seriously injure or kill you or bystanders.

- Always replace bent or damaged blade with a new blade.
- Never file or create sharp notches in the edges or surfaces of blade.

Checking for Bent Blades

1. Disengage the blade-control switch (PTO), move the motion-control levers to the neutral-locked position, and set the parking brake.
2. Stop the engine, remove the key, and wait for all moving parts to stop before leaving the operating position.
3. Rotate the blades until the ends face forward and backward (Figure 93).

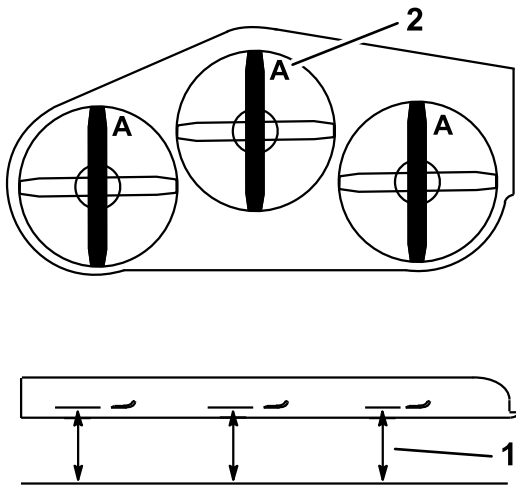

Figure 93

- | | |
|--|---------------|
| 1. Measure here from blade to hard surface | 2. Position A |
|--|---------------|

4. Measure from a level surface to the cutting edge, position **A**, of the blades (Figure 93).
5. Rotate the opposite ends of the blades forward.
6. Measure from a level surface to the cutting edge of the blades at the same position as in step 3 above.

Note: The difference between the dimensions obtained in steps 3 and 5 must not exceed 3 mm (1/8 inch). If this dimension exceeds 3 mm (1/8 inch), the blade is bent and must be replaced; refer to

Removing the Blades

Blades must be replaced if a solid object is hit, if the blade is out of balance or is bent. To ensure optimum performance and continued safety conformance of the machine, use genuine Toro replacement blades. Replacement blades made by other manufacturers may result in non-conformance with safety standards.

1. Hold the blade end using a rag or thickly padded glove.
2. Remove the blade bolt, the curved washer, and the blade from the spindle shaft (Figure 94).

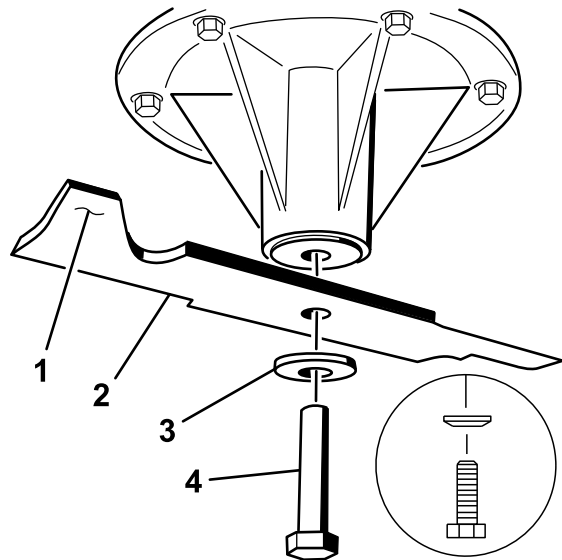

Figure 94

- | | |
|-----------------------|------------------|
| 1. Sail area of blade | 3. Curved washer |
| 2. Blade | 4. Blade bolt |

Sharpening the Blades

⚠ WARNING

When sharpening blade, pieces of blade could be thrown and cause serious injury.

Wear proper eye protection when sharpening blade.

1. Use a file to sharpen the cutting edge at both ends of the blade (Figure 95).

Note: Maintain the original angle. The blade remains balanced if the same amount of material is removed from both cutting edges.

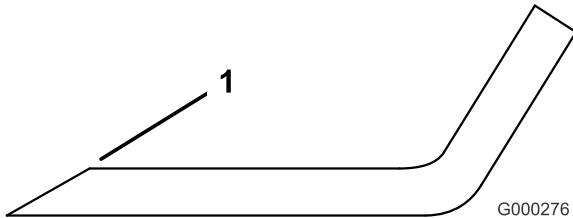

Figure 95

1. Sharpen at original angle

2. Check the balance of the blade by putting it on a blade balancer (Figure 96).

Note: If the blade stays in a horizontal position, the blade is balanced and can be used. If the blade is not balanced, file some metal off the end of the sail area only (Figure 97). Repeat this procedure until the blade is balanced.

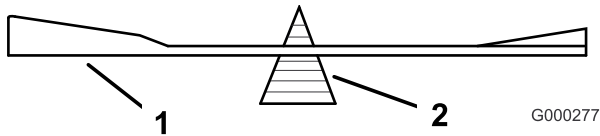

Figure 96

1. Blade
2. Balancer

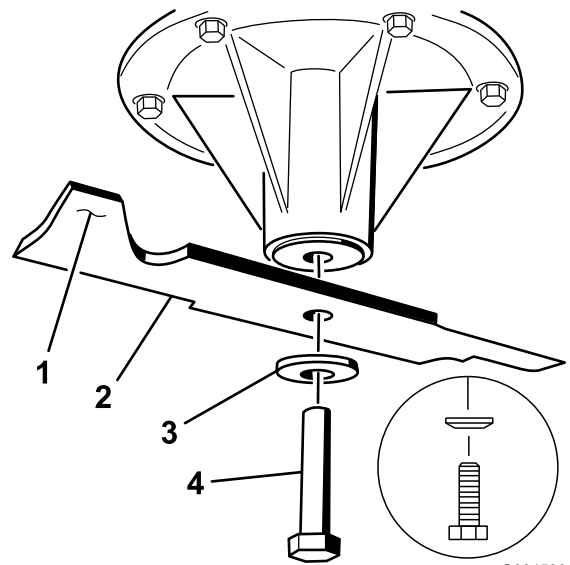

Figure 97

1. Sail area of blade
2. Blade
3. Spring disk
4. Blade bolt
5. Cone toward the bolt head

Installing the Blades

1. Install the blade onto the spindle shaft (Figure 97).

Important: The curved part of the blade must point upward toward the inside of the mower to ensure proper cutting.

2. Install the spring disk and the blade bolt.

Note: Install the spring disk cone toward the bolt head (Figure 97). Torque the blade bolt to 115 to 150 N-m (85 to 110 ft-lb).

Removing the Mower Deck

Before servicing or removing the mower deck, the spring-loaded deck arms must be locked out.

⚠ WARNING

Deck lift arm assemblies have stored energy. Removing the deck with out releasing the stored energy can cause serious injury or death.

Do not attempt to disassemble the deck from the front frame without locking out the stored energy.

1. Stop engine, wait for all moving parts to stop, and remove key. Engage parking brake.
2. Remove the height-adjustment pin and lower the deck to the ground.
3. Place the height adjustment pin in the 7.6 cm (3 inch) cutting-height location. This locks the deck lift arms in the lowest position when the deck is removed and the stored energy in the deck spring is released.
4. Remove the belt covers.
5. Remove the bolts holding the floor pan down.
6. Lift up the floor pan and insert a ratchet into the square hole in the deck idler ([Figure 98](#)).
7. Rotate the deck idler clockwise and remove the mower belt ([Figure 98](#)).

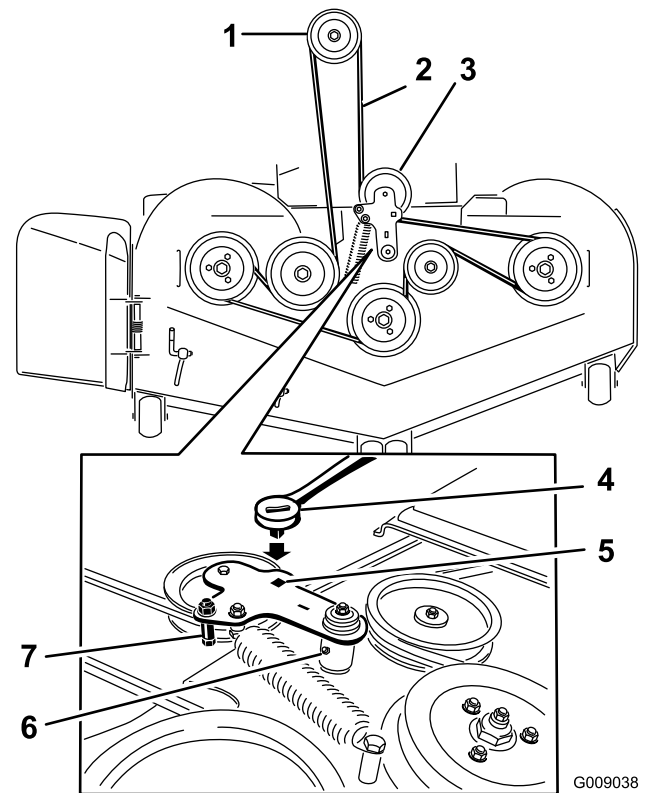

Figure 98

- | | |
|-------------------------------|---|
| 1. Clutch pulley | 5. Square hole in the idler arm for the ratchet |
| 2. Mower belt | 6. Idler grease fitting |
| 3. Spring loaded idler pulley | 7. Belt guide |
| 4. Ratchet | |
-
8. Remove and retain the hardware on both sides of the deck as shown in [Figure 99](#).

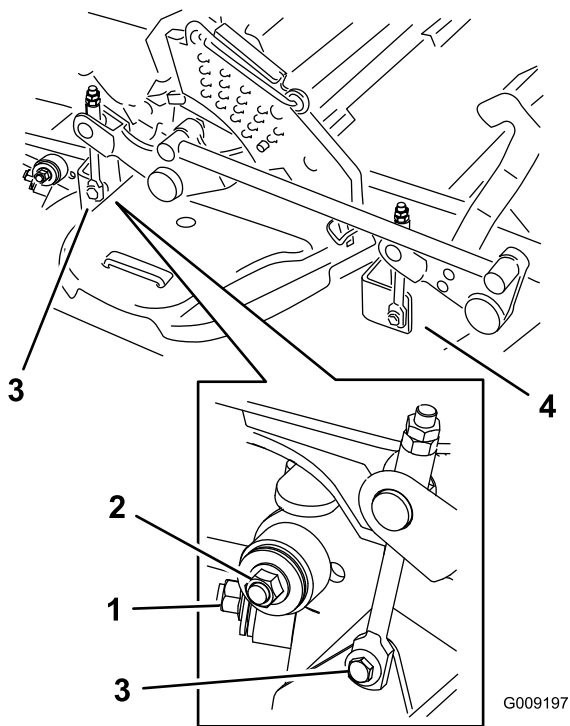

Figure 99

1. Right stabilizer
2. Deck strut (right side shown)
3. Remove the rear deck lift attachment shoulder bolt and nut.
4. Remove the front deck lift attachment shoulder bolt and nut.

9. Raise the deck struts and secure them in the up position. Slide the deck out to the right side of the machine.

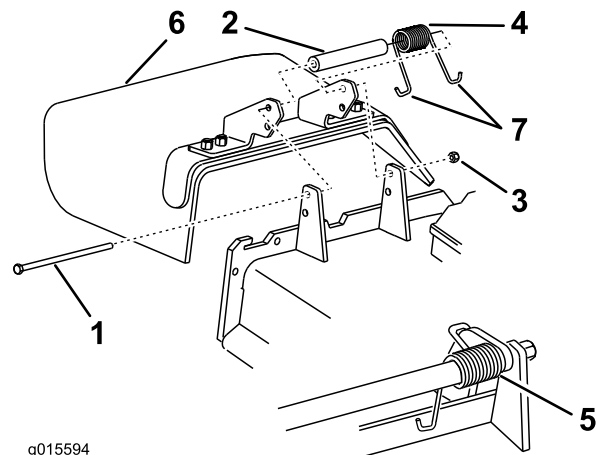

Figure 100

- | | |
|------------|-------------------------|
| 1. Bolt | 5. Spring installed |
| 2. Spacer | 6. Grass deflector |
| 3. Locknut | 7. J-hook end of spring |
| 4. Spring | |

2. Place the spacer and spring onto the grass deflector. Place one **J**-end of the spring behind the deck edge.

Note: Make sure that one **J**-end of the spring is installed behind the deck edge before installing the bolt as shown in [Figure 100](#).

3. Install the bolt and the nut. Place one **J**-hook end of the spring around the grass deflector ([Figure 100](#)).

Important: The grass deflector must be able to rotate. Lift the deflector up to the full open position and ensure that it rotates into the full down position.

Replacing the Grass Deflector

▲ WARNING

An uncovered discharge opening could allow the lawn mower to throw objects in the operator's or bystander's direction and result in serious injury. Also, contact with the blade could occur.

Never operate the lawn mower unless you install a cover plate, a mulch plate, grass deflector or bagger.

1. Remove the locknut, bolt, spring and spacer holding the deflector to the pivot brackets ([Figure 100](#)). Remove damaged or worn grass deflector.

Cleaning

Cleaning under the Mower

Service Interval: Before each use or daily

1. Disengage the blade-control switch (PTO), move the motion-control levers to the neutral-locked position, and set the parking brake.
2. Stop the engine, remove the key, and wait for all moving parts to stop before leaving the operating position.
3. Raise the mower to the transport position.

Disposing of Waste

Engine oil, batteries, hydraulic oil, and engine coolant are pollutants to the environment. Dispose of these according to your state and local regulations.

Storage

Cleaning and Storage

1. Disengage the power take off (blade-control switch (PTO), set the parking brake, and turn the ignition key to the off position. Remove the key.
2. Remove grass clippings, dirt, and grime from the external parts of the entire machine, especially the engine and hydraulic system. Clean dirt and chaff from the outside of the engine cylinder head fins and blower housing.

Important: You can wash the machine with mild detergent and water. Do not pressure wash the machine. Avoid excessive use of water, especially near the control panel, engine, hydraulic pumps, and motors.

3. Check the brake; refer to [Brake Maintenance \(page 50\)](#).
4. Service the air cleaner; refer to [Servicing the Air Cleaner \(page 38\)](#).
5. Grease the machine; refer to [Lubrication \(page 36\)](#).
6. Change the crankcase oil; refer to [Changing the Engine Oil \(page 40\)](#).

Check the tire pressure; refer to [Checking the Tire Pressure \(page 47\)](#).

7. Change the hydraulic filters; refer to [Replacing the Hydraulic Filters and Hydraulic Oil \(page 56\)](#).
8. Charge the battery; refer to [Charging the Battery \(page 45\)](#).
9. Scrape any heavy buildup of grass and dirt from the underside of the mower, then wash the mower with a garden hose.

Note: Run the machine with the blade-control switch (PTO) engaged and the engine at high idle for 2 to 5 minutes after washing.

10. Check the condition of the blades; refer to [Servicing the Cutting Blades \(page 59\)](#).
11. For storage over 30 days, prepare the machine as follows:
 - A. Add a petroleum-based stabilizer/conditioner to fuel in the tank. Follow mixing instructions from the stabilizer manufacturer. Do not use an alcohol-based stabilizer (ethanol or methanol).

Note: A fuel stabilizer/conditioner is most effective when mixed with fresh fuel and used at all times.
 - B. Run the engine to distribute conditioned fuel through the fuel system (5 minutes).
 - C. Stop the engine, allow it to cool, and drain the fuel tank; refer to [Servicing the Fuel Tank \(page 43\)](#).
 - D. Restart the engine and run it until it stops.

- E. Dispose of fuel properly. Recycle as per local codes.

Important: Do not store stabilizer/conditioned fuel over 90 days.

- 12. Check and tighten all bolts, nuts, and screws. Repair or replace any part that is damaged.
- 13. Paint all scratched or bare metal surfaces. Paint is available from your Authorized Service Dealer.
- 14. Store the machine in a clean, dry garage or storage area. Remove the key from the ignition switch and keep it out of reach of children or other unauthorized users. Cover the machine to protect it and keep it clean.

Troubleshooting

Problem	Possible Cause	Corrective Action
The starter does not crank.	<ol style="list-style-type: none"> 1. The blade-control switch (PTO) is engaged. 2. The parking brake is not on. 3. The motion-control levers are not in the neutral-lock position. 4. The operator is not seated. 5. The battery is dead. 6. The electrical connections are corroded or loose. 7. The fuse is blown. 8. The relay or switch is worn or damaged. 	<ol style="list-style-type: none"> 1. Move the blade-control switch (PTO) to the disengaged position. 2. Set the parking brake. 3. Ensure that the motion-control levers are in the neutral-lock position. 4. Sit on the seat. 5. Charge the battery. 6. Check the electrical connections for good contact. 7. Replace the fuse. 8. Contact an Authorized Service Dealer.
The engine does not start, starts hard, or fails to keep running.	<ol style="list-style-type: none"> 1. The fuel tank is empty. 2. The fuel-shutoff valve is closed. 3. The oil level in the crankcase is low. 4. The throttle is not in the correct position. 5. There is dirt in the fuel filter. 6. There is dirt, water, or stale fuel in the fuel system. 7. The air cleaner is dirty. 8. The seat switch is not functioning properly. 9. The electrical connections are corroded, loose, or damaged. 10. The relay or switch is worn or damaged. 11. The spark plug is fouled or improperly gapped. 12. The spark-plug wire is not connected. 	<ol style="list-style-type: none"> 1. Fill the fuel tank. 2. Open the fuel-shutoff valve. 3. Add oil to the crankcase. 4. Be sure that the throttle control is midway between the slow and fast positions. 5. Replace the fuel filter. 6. Contact an Authorized Service Dealer. 7. Clean or replace the air-cleaner element. 8. Check the seat-switch indicator. Replace the seat if necessary. 9. Check the electrical connections for good contact. Clean the connector terminals thoroughly with electrical-contact cleaner, apply dielectric grease, and make the appropriate connections. 10. Contact an Authorized Service Dealer. 11. Adjust or replace the spark plug. 12. Check the spark-plug wire connection.
The engine loses power.	<ol style="list-style-type: none"> 1. The engine load is excessive. 2. The air cleaner is dirty. 3. The oil level in the crankcase is low. 4. The cooling fins and the air passages above the engine are plugged. 5. The vent hole in the fuel cap is plugged. 6. There is dirt in the fuel filter. 7. There is dirt, water, or stale fuel in the fuel system. 	<ol style="list-style-type: none"> 1. Reduce the ground speed. 2. Clean the air-cleaner element. 3. Add oil to the crankcase. 4. Remove the obstruction from the cooling fins and the air passages. 5. Clean or replace the fuel cap. 6. Replace the fuel filter. 7. Contact an Authorized Service Dealer.
The engine overheats.	<ol style="list-style-type: none"> 1. The engine load is excessive. 2. The oil level in the crankcase is low. 3. The cooling fins and the air passages above the engine are plugged. 	<ol style="list-style-type: none"> 1. Reduce the ground speed. 2. Add oil to the crankcase. 3. Remove the obstruction from the cooling fins and the air passages.
The mower pulls to the left or right (with levers fully forward)	<ol style="list-style-type: none"> 1. The tracking needs adjustment 2. The tire pressure in the drive tires is not correct. 	<ol style="list-style-type: none"> 1. Adjust the tracking. 2. Adjust the tire pressure in the drive tires.

Problem	Possible Cause	Corrective Action
The machine does not drive.	<ol style="list-style-type: none"> 1. The bypass valves are not closed tight. 2. The pump belt is worn, loose, or broken. 3. The pump belt is off a pulley. 4. The idler spring is broken or missing. 5. The hydraulic oil level is low or too hot. 	<ol style="list-style-type: none"> 1. Tighten the bypass valves. 2. Change the belt. 3. Change the belt. 4. Replace the spring. 5. Add hydraulic oil to the reservoirs or let it cool down.
The machine vibrates abnormally.	<ol style="list-style-type: none"> 1. The cutting blade(s) is/are bent or unbalanced. 2. The blade mounting bolt is loose. 3. The engine mounting bolts are loose. 4. The engine pulley, idler pulley, or blade pulley is loose. 5. The engine pulley is damaged. 6. The blade spindle is bent. 7. The motor mount is loose or worn. 	<ol style="list-style-type: none"> 1. Install new cutting blade(s). 2. Tighten the blade mounting bolt. 3. Tighten the engine mounting bolts. 4. Tighten the appropriate pulley. 5. Contact an Authorized Service Dealer. 6. Contact an Authorized Service Dealer. 7. Contact an Authorized Service Dealer.
The machine produces an uneven cutting height.	<ol style="list-style-type: none"> 1. The blade(s) is/are not sharp. 2. The cutting blade(s) is/are bent. 3. The mower deck is not level. 4. The underside of mower is dirty. 5. The tire pressure is not correct. 6. The blade spindle is bent. 	<ol style="list-style-type: none"> 1. Sharpen the blade(s). 2. Install new cutting blade(s). 3. Level the mower deck from side-to-side and front-to-rear. 4. Clean the underside of the mower. 5. Adjust the tire pressure. 6. Contact an Authorized Service Dealer.
The blades do not rotate.	<ol style="list-style-type: none"> 1. The mower deck belt is worn, loose, or broken. 2. The mower deck belt is off pulley. 3. The pump drive belt is worn, loose, or broken. 4. The idler spring is broken or missing. 	<ol style="list-style-type: none"> 1. Install a new deck belt. 2. Install the mower deck pulley and check the idler pulley, idler arm, and spring for correct position and function. 3. Check the belt tension or install a new belt. 4. Replace the spring.
The clutch does not engage.	<ol style="list-style-type: none"> 1. The fuse is blown. 2. There is low voltage supply at the clutch. 3. The coil is damaged. 4. There is inadequate current supply. 5. The rotor/armature air gap is too large. 	<ol style="list-style-type: none"> 1. Replace the fuse. Check the coil resistance, battery charge, charging system, and wiring connections, and replace components if necessary. 2. Check the coil resistance, battery charge, charging system, and wiring connections and replace parts if necessary. 3. Replace the clutch. 4. Repair or replace the clutch lead wire or electrical system. Clean the connector contacts. 5. Remove the shim or replace the clutch.

Schematics

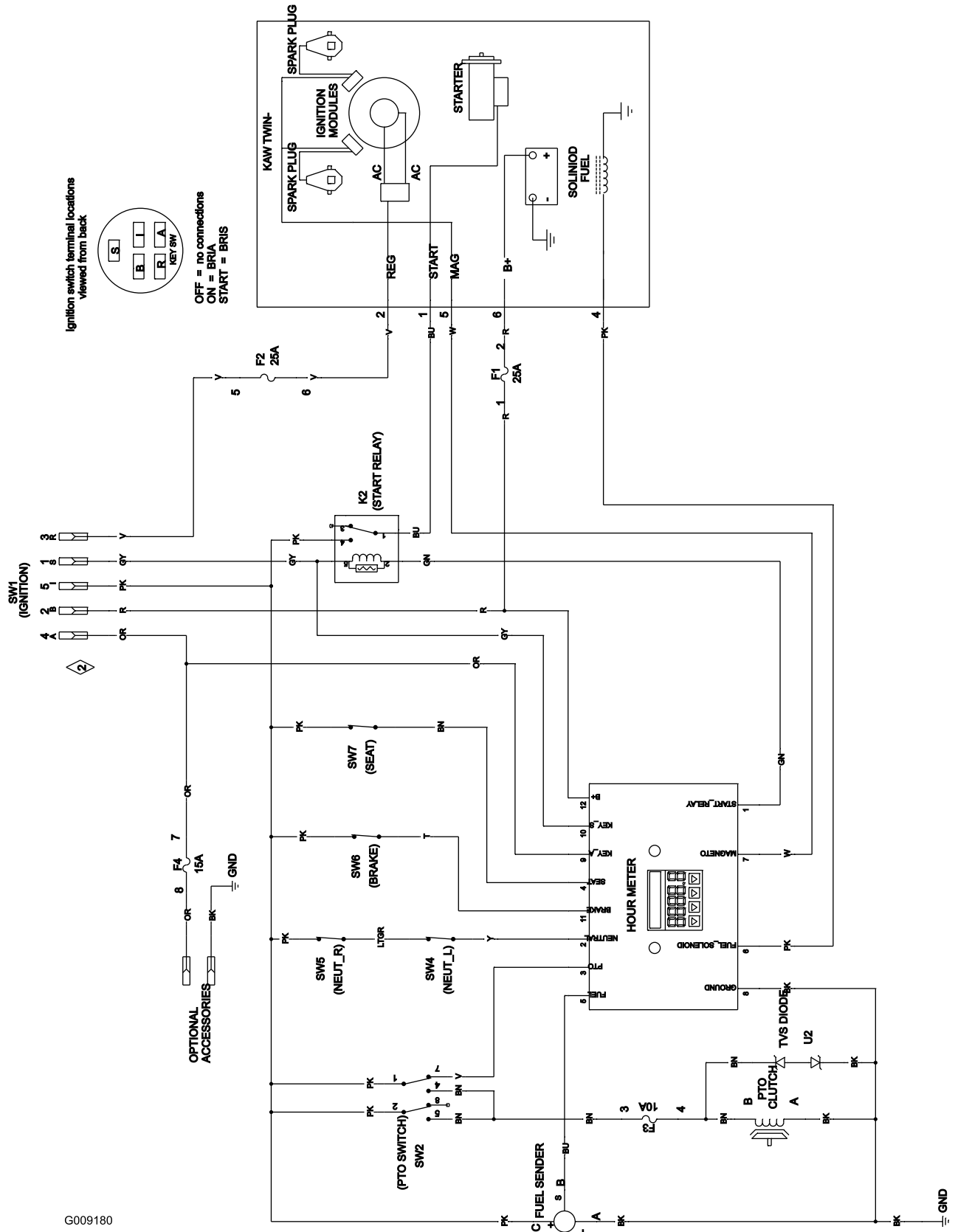

Wire Diagram (Rev. A)

G009180

Notes:

Notes:

International Distributor List

Distributor:	Country:	Phone Number:	Distributor:	Country:	Phone Number:
Agrolanc Kft	Hungary	36 27 539 640	Maquiver S.A.	Colombia	57 1 236 4079
Balama Prima Engineering Equip.	Hong Kong	852 2155 2163	Maruyama Mfg. Co. Inc.	Japan	81 3 3252 2285
B-Ray Corporation	Korea	82 32 551 2076	Mountfield a.s.	Czech Republic	420 255 704 220
Casco Sales Company	Puerto Rico	787 788 8383	Mountfield a.s.	Slovakia	420 255 704 220
Ceres S.A.	Costa Rica	506 239 1138	Munditol S.A.	Argentina	54 11 4 821 9999
CSSC Turf Equipment (pvt) Ltd.	Sri Lanka	94 11 2746100	Norma Garden	Russia	7 495 411 61 20
Cyril Johnston & Co.	Northern Ireland	44 2890 813 121	Oslinger Turf Equipment SA	Ecuador	593 4 239 6970
Cyril Johnston & Co.	Republic of Ireland	44 2890 813 121	Oy Hako Ground and Garden Ab	Finland	358 987 00733
Equiver	Mexico	52 55 539 95444	Parkland Products Ltd.	New Zealand	64 3 34 93760
Femco S.A.	Guatemala	502 442 3277	Perfetto	Poland	48 61 8 208 416
ForGarder OU	Estonia	372 384 6060	Pratoverde SRL.	Italy	39 049 9128 128
G.Y.K. Company Ltd.	Japan	81 726 325 861	Prochaska & Cie	Austria	43 1 278 5100
Geomechaniki of Athens	Greece	30 10 935 0054	RT Cohen 2004 Ltd.	Israel	972 986 17979
Golf international Turizm	Turkey	90 216 336 5993	Riversa	Spain	34 9 52 83 7500
Guandong Golden Star	China	86 20 876 51338	Lely Turfcare	Denmark	45 66 109 200
Hako Ground and Garden	Sweden	46 35 10 0000	Solvart S.A.S.	France	33 1 30 81 77 00
Hako Ground and Garden	Norway	47 22 90 7760	Spypros Stavrinides Limited	Cyprus	357 22 434131
Hayter Limited (U.K.)	United Kingdom	44 1279 723 444	Surge Systems India Limited	India	91 1 292299901
Hydroturf Int. Co Dubai	United Arab Emirates	97 14 347 9479	T-Markt Logistics Ltd.	Hungary	36 26 525 500
Hydroturf Egypt LLC	Egypt	202 519 4308	Toro Australia	Australia	61 3 9580 7355
Irrimac	Portugal	351 21 238 8260	Toro Europe NV	Belgium	32 14 562 960
Irrigation Products Int'l Pvt Ltd.	India	0091 44 2449 4387	Valtech	Morocco	212 5 3766 3636
Jean Heybroek b.v.	Netherlands	31 30 639 4611	Victus Emak	Poland	48 61 823 8369

European Privacy Notice

The Information Toro Collects

Toro Warranty Company (Toro) respects your privacy. In order to process your warranty claim and contact you in the event of a product recall, we ask you to share certain personal information with us, either directly or through your local Toro company or dealer.

The Toro warranty system is hosted on servers located within the United States where privacy law may not provide the same protection as applies in your country.

BY SHARING YOUR PERSONAL INFORMATION WITH US, YOU ARE CONSENTING TO THE PROCESSING OF YOUR PERSONAL INFORMATION AS DESCRIBED IN THIS PRIVACY NOTICE.

The Way Toro Uses Information

Toro may use your personal information to process warranty claims, to contact you in the event of a product recall and for any other purpose which we tell you about. Toro may share your information with Toro's affiliates, dealers or other business partners in connection with any of these activities. We will not sell your personal information to any other company. We reserve the right to disclose personal information in order to comply with applicable laws and with requests by the appropriate authorities, to operate our systems properly or for our own protection or that of other users.

Retention of your Personal Information

We will keep your personal information as long as we need it for the purposes for which it was originally collected or for other legitimate purposes (such as regulatory compliance), or as required by applicable law.

Toro's Commitment to Security of Your Personal Information

We take reasonable precautions in order to protect the security of your personal information. We also take steps to maintain the accuracy and current status of personal information.

Access and Correction of your Personal Information

If you would like to review or correct your personal information, please contact us by email at legal@toro.com.

Australian Consumer Law

Australian customers will find details relating to the Australian Consumer Law either inside the box or at your local Toro Dealer.



The Toro Total Warranty

Landscape
Contractor
Equipment (LCE)

Conditions and Products Covered

The Toro Company and its affiliate, Toro Warranty Company, pursuant to an agreement between them, jointly promise to the original purchaser to repair the Toro Products listed below if defective in materials or workmanship.

The following time periods apply from the date of purchase by the original owner:

Products	Warranty Period
Walk Behind Mowers	
53 cm Mowers – Residential use ¹	2 years
53 cm Mowers – Commercial use	1 year
76 cm Mowers – Residential use ¹	2 years
76 cm Mowers – Commercial use	1 year
Mid-Size Walk-Behind Mowers	2 years
• Engine	2 years ²
Grand Stand® Mowers	5 years or 1,200 hours ³
• Engine	2 years
• Frame	Lifetime (original owner only) ⁴
Z Master® 2000 Series Mowers	4 years or 500 hours ³
• Engine	2 years ²
• Frame	Lifetime (original owner only) ⁴
Z Master® 3000 Series Mowers	5 years or 1,200 hours ³
• Engine	2 years ²
• Frame	Lifetime (original owner only) ⁴
Z Master® 5000 and 6000 Series Mowers	5 years or 1,200 hours ³
• Engine	2 years ²
• Frame	Lifetime (original owner only) ⁴
Z Master® 7000 Series Mowers	5 years or 1,200 hours ³
• Engine	2 years ²
• Frame	Lifetime (original owner only) ⁴
All Mowers	
• Battery	2 years
• Attachments	2 years

¹Residential use means use of the product on the same lot as your home. Use at more than one location is considered commercial use and the commercial warranty would apply.

²Some engines used on Toro LCE Products are warranted by the engine manufacturer.

³Whichever occurs first.

⁴Lifetime Frame Warranty - If the main frame, consisting of the parts welded together to form the tractor structure that other components such as the engine are secured to, cracks or breaks in normal use, it will be repaired or replaced under warranty at no cost for parts and labor. Frame failure due to misuse or abuse and failure or repair required due to rust or corrosion are not covered.

This warranty includes the cost of parts and labor, but you must pay transportation costs.

Instructions for Obtaining Warranty Service

If you think that your Toro Product contains a defect in materials or workmanship, follow this procedure:

1. Contact your seller to arrange service of the product. If for any reason it is impossible for you to contact your seller, you may contact any Toro Authorized Distributor to arrange service.
2. Bring the product and your proof of purchase (sales receipt) to the Service Dealer.
3. If for any reason you are dissatisfied with the Service Dealer's analysis or with the assistance provided, contact us at:

RLC Customer Care Department

Toro Warranty Company
8111 Lyndale Avenue South
Bloomington, MN 55420-1196
001-952-948-4707

See attached Distributor List.

Owner Responsibilities

You must maintain your Toro Product by following the maintenance procedures described in the *Operator's Manual*. Such routine maintenance, whether performed by a dealer or by you, is at your expense.

Items and Conditions Not Covered

There is no other express warranty except for special emission system coverage and engine warranty coverage on some products. This express warranty does not cover the following:

- Cost of regular maintenance service or parts, such as filters, fuel, lubricants, oil changes, spark plugs, air filters blade sharpening or worn blades, cable/linkage adjustments, or brake and clutch adjustments
- Components failing due to normal wear
- Any product or part which has been altered or misused or neglected and requires replacement or repair due to accidents or lack of proper maintenance
- Pickup and delivery charges
- Repairs or attempted repairs by anyone other than an Authorized Toro Service Dealer
- Repairs necessary due to failure to follow recommended fuel procedure (consult *Operator's Manual* for more details)
 - Removing contaminants from the fuel system is not covered
 - Use of old fuel (more than one month old) or fuel which contains more than 10% ethanol or more than 15% MTBE
 - Failure to drain the fuel system prior to any period of non-use over one month

General Conditions

The purchaser is covered by the national laws of each country. The rights to which the purchaser is entitled with the support of these laws are not restricted by this warranty.