



Count on it.

Operator's Manual

**Workman® HD Utility Vehicle with
Bed**

Model No. 07369—Serial No. 315000001 and Up



This machine is a utility vehicle intended to be used by professional, hired operators in commercial applications. It is primarily designed for the transport of implements used in such applications. This vehicle allows for the safe transport of an operator and one passenger in the identified seats. The bed of this vehicle is not suitable for any riders.

⚠ WARNING

CALIFORNIA
Proposition 65 Warning

This product contains a chemical or chemicals known to the State of California to cause cancer, birth defects, or reproductive harm.

The engine exhaust from this product contains chemicals known to the State of California to cause cancer, birth defects, or other reproductive harm.

Important: The engine in this product is not equipped with a spark arrester muffler. It is a violation of California Public Resource Code Section 4442 to use or operate this engine on any forest-covered, brush-covered, or grass-covered land as defined in CPRC 4126. Other states or federal areas may have similar laws.

Introduction

Read this information carefully to learn how to operate and maintain your product properly and to avoid injury and product damage. You are responsible for operating the product properly and safely.

You may contact Toro directly at www.Toro.com for product safety and operation training materials, accessory information, help finding a dealer, or to register your product.

Whenever you need service, genuine Toro parts, or additional information, contact an Authorized Service Dealer or Toro Customer Service and have the model and serial numbers of your product ready. [Figure 1](#) identifies the location of the model and serial numbers on the product. Write the numbers in the space provided.

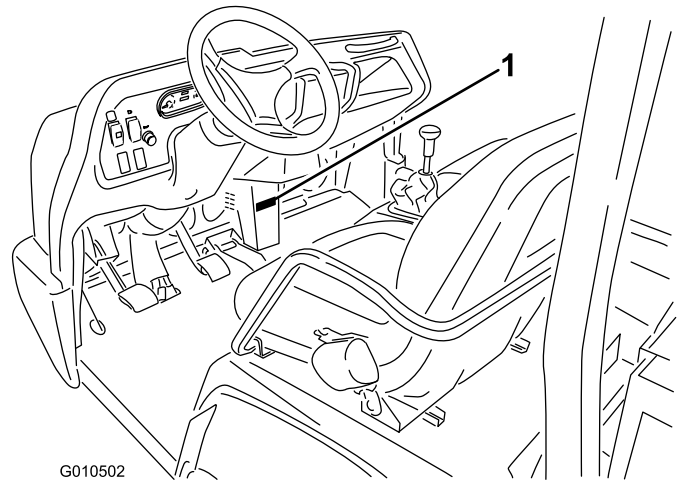

Figure 1

1. Model and serial number location

Model No. _____
Serial No. _____

This manual identifies potential hazards and has safety messages identified by the safety alert symbol ([Figure 2](#)), which signals a hazard that may cause serious injury or death if you do not follow the recommended precautions.



Figure 2

1. Safety alert symbol

This manual uses 2 other words to highlight information. **Important** calls attention to special mechanical information and **Note** emphasizes general information worthy of special attention.

Contents

Safety	4	Servicing the Air Cleaner	35
Safe Operating Practices	4	Changing the Engine Oil And Filter	35
Supervisor's Responsibilities	4	Replacing the Spark Plugs	36
Before Operating	4	Fuel System Maintenance	37
While Operating.....	4	Replacing the Fuel Filter.....	37
Maintenance	5	Inspecting the Fuel Lines and Connections.....	37
Safety and Instructional Decals	6	Electrical System Maintenance	37
Setup	12	Servicing the Fuses	37
1 Checking the Fluid Levels	12	Jump Starting the Machine.....	38
2 Installing the ROPS.....	12	Servicing the Battery	38
Product Overview	13	Drive System Maintenance	39
Controls	13	Adjusting the Shift Cables.....	39
Specifications	16	Adjusting the High–Low Cable	39
Attachments/Accessories.....	16	Adjusting Differential Lock Cable.....	39
Operation	17	Inspecting the Tires	40
Operating the Cargo Box.....	17	Checking the Front-wheel Alignment	40
Checking the Engine Oil Level	17	Cooling System Maintenance	41
Adding Fuel.....	18	Removing Debris from the Engine Cooling	
Checking the Transaxle/Hydraulic Fluid		System	41
Level.....	19	Brake Maintenance	42
Checking the Torque of the Wheel Nuts.....	20	Adjusting the Parking Brake.....	42
Checking the Tire Pressure	20	Adjusting the Brake Pedal.....	42
Checking the Brake-fluid Level.....	21	Belt Maintenance	43
Starting the Engine	21	Checking the Pump Belt Tension	43
Driving the Machine	22	Adjusting the Pump Drive Belt	43
Stopping the Machine	22	Controls System Maintenance	43
Stopping the Engine	22	Adjusting the Clutch Pedal.....	43
Breaking in a New Machine.....	22	Adjusting the Accelerator	44
Checking the Safety-interlock System	22	Adjusting the Choke	45
Ensuring Passenger Safety	23	Converting the Speedometer.....	45
Ensuring Proper Speed	23	Hydraulic System Maintenance	45
Ensuring Proper Turning.....	23	Changing the Hydraulic Fluid and Cleaning the	
Ensuring Proper Braking.....	24	Strainer.....	45
Preventing Tip Overs.....	24	Replacing the Hydraulic Filter	46
Operating on Hills.....	24	Raising the Box in an Emergency.....	46
Loading and Dumping	24	Cleaning	48
Using The Differential Lock	25	Washing the Machine	48
Transporting the Machine.....	25	Storage	49
Towing the Machine	26	Troubleshooting	50
Towing a Trailer with the Machine.....	26		
Using the Hydraulic Control	26		
Maintenance	28		
Recommended Maintenance Schedule(s)	28		
Service Interval Chart	29		
Operating in Adverse Conditions.....	30		
Pre-maintenance Procedures	30		
Using the Bed Support	30		
Removing the Full Bed.....	30		
Installing the Full Bed	31		
Raising the Machine.....	32		
Removing the Hood	32		
Installing the Hood.....	33		
Lubrication	33		
Greasing Bearings and Bushings	33		
Engine Maintenance	35		
Inspecting the Carbon Canister Air Filter	35		

Safety

Safe Operating Practices

Important: The machine is designed primarily as an off-road vehicle and is not intended for extensive use on public roads.

When using the machine on public roads, follow all traffic regulations and use any additional accessories that may be required by law, such as lights, turn signals, slow moving vehicle (SMV) sign, and others as required.

The Workman was designed and tested to offer safe service when operated and maintained properly. Although hazard control and accident prevention partially are dependent upon the design and configuration of the machine, these factors are also dependent upon the awareness, concern, and proper training of the personnel involved in the operation, maintenance and storage of the machine. Improper use or maintenance of the machine can result in injury or death.

This is a specialized utility vehicle designed for off-road use only. Its ride and handling will have a different feel than what drivers experience with passenger cars or trucks. So take time to become familiar with your machine.

Not all of the attachments that adapt to the machine are covered in this manual. See the specific *Operator's Manual* provided with each attachment for additional safety instructions. **Read these manuals.**

To reduce the potential for injury or death, comply with the following safety instructions:

Supervisor's Responsibilities

- Make sure operators are thoroughly trained and familiar with the *Operator's Manual* and all decals on the machine.
- Be sure to establish your own special procedures and work rules for unusual operating conditions (e.g. slopes too steep for machine operation). Use the 3rd High Lockout switch if high speed could result in a safety or machine abuse situation.

Before Operating

- Operate the machine only after reading and understanding the contents of this manual.
- **Never** allow children to operate the machine. **Never** allow adults to operate it without proper instructions. Only trained and authorized persons should operate this machine. Make sure all operators are physically and mentally capable of operating the machine.
- This machine is designed to carry **only you**, the operator, and **one passenger** in the seat provided by the manufacturer. **Never** carry any other passengers on the machine.
- **Never** operate the machine when under the influence of drugs or alcohol.

- Become familiar with the controls and know how to stop the engine quickly.
- Keep all shields, safety devices and decals in place. If a shield, safety device or decal is malfunctioning, illegible, or damaged, repair or replace it before operating the machine.
- Always wear substantial shoes. Do not operate the machine while wearing sandals, tennis shoes, or sneakers. Do not wear loose fitting clothing or jewelry which could get caught in moving parts and cause personal injury.
- Wearing safety glasses, safety shoes, long pants, and a helmet is advisable and required by some local safety and insurance regulations.
- Keep everyone, especially children and pets, away from the areas of operation.
- Before operating the machine, always check all parts of the machine and any attachments. If something is wrong, **stop using machine**. Make sure the problem is corrected before machine or attachment is operated again.
- Since gasoline is highly flammable, handle it carefully.
 - Use an approved fuel container.
 - Do not remove the cap from the fuel tank when the engine is hot or running.
 - Do not smoke while handling fuel.
 - Fill the fuel tank outdoors and to about one inch below the top of tank (bottom of filler neck). **Do not overfill.**
 - Wipe up any spilled fuel.
- Operate the machine only outdoors or in a well ventilated area.
- Use only an approved nonmetal, portable fuel container. Static electric discharge can ignite fuel vapors in a ungrounded fuel container. Remove the fuel container from the bed of the machine and place it on the ground away from the machine before filling. Keep the nozzle in contact with the container while filling. Remove equipment from machine bed before filling.
- Check the safety interlock system daily for proper operation. If a switch should malfunction, replace the switch before operating machine.

While Operating

- The operator and passenger should use seat belts and remain seated whenever the machine is in motion. The operator should keep both hands on the steering wheel, whenever possible, and the passenger should use the hand holds provided. Keep arms and legs within the machine body at all times. Never carry passengers in the box or on attachments. Remember your passenger may not be expecting you to brake or turn and may not be ready.
- Never overload your machine. The name plate (located under the middle of the dash) shows the load limits for

the machine. Never overfill attachments or exceed the machine maximum gross machine weight (GVW).

- When starting the engine:
 - Sit on operator’s seat and ensure that the parking brake is engaged.
 - Disengage PTO (if so equipped) and return the hand throttle lever to the Off position (if so equipped).
 - Move shift lever to Neutral and press clutch pedal.
 - Make sure the hydraulic lift lever is in the center position.
 - **If engine is cold**—press and hold the accelerator pedal about half way down and pull the choke knob out to the On position while cranking the engine.
 - **If engine is hot**—press and hold the accelerator pedal about half way down while cranking the engine.
 - **If engine is flooded**—fully press accelerator pedal and hold it to the floor until the engine starts. Never pump the accelerator pedal.
 - Using the machine demands attention. Failure to operate machine safely may result in an accident, tip over of the machine, and serious injury or death. Drive carefully. To prevent tipping or loss of control, take the following precautions:
 - Use extreme caution, reduce speed, and maintain a safe distance around sand traps, ditches, creeks, ramps, any unfamiliar areas, or other hazards.
 - Watch for holes or other hidden hazards.
 - Use caution when operating the machine on a steep slope. Normally, travel straight up and down slopes. Reduce speed when making sharp turns or when turning on hillsides. Avoid turning on hillsides whenever possible.
 - Use extra caution when operating the machine on wet surfaces, at higher speeds, or with a full load. Stopping time will increase with a full load. Shift into a lower gear before starting up or down a hill.
 - When loading the bed, distribute the load evenly. Use extra caution if the load exceeds the dimensions of the machine/bed. Operate the machine with extra caution when handling off-center loads that cannot be centered. Keep loads balanced and secure to prevent them from shifting.
 - Avoid sudden stops and starts. Do not go from reverse to forward or forward to reverse without first coming to a complete stop.
 - Do not attempt sharp turns or abrupt maneuvers or other unsafe driving actions that may cause a loss of machine control.
 - Do not pass another machine traveling in the same direction at intersections, blind spots, or at other dangerous locations.
 - When dumping, do not let anyone stand behind machine and do not dump the load on any one’s feet.
 - Release the tailgate latches from the side of box, not from behind.
 - Keep all bystanders away. Before backing up, look to the rear and ensure that no one is behind the machine. Back up slowly.
 - Watch out for traffic when near or crossing roads. Always yield the right of way to pedestrians and other machines. This machine is not designed for use on streets or highways. Always signal your turns or stop early enough so other persons know what you plan to do. Obey all traffic rules and regulations.
 - Never operate the machine in or near an area where there is dust or fumes in the air which are explosive. The electrical and exhaust systems of the machine can produce sparks capable of igniting explosive materials.
 - Always watch out for and avoid low overhangs such as tree limbs, door jambs, over head walkways, etc. Make sure there is enough room over head to easily clear the machine and your head.
 - If ever unsure about safe operation, **stop work** and ask your supervisor.
- Do not touch engine, transaxle, muffler, or muffler manifold while the engine is running or soon after it has stopped because these areas may be hot enough to cause burns.
 - If the machine ever vibrates abnormally, stop immediately, turn the engine off, wait for all motion to stop and inspect for damage. Repair all damage before resuming operation.
 - Before getting off the seat, do the following:
 - Stop movement of the machine.
 - Lower the bed.
 - Shut the engine off and wait for all movement to stop.
 - Set the parking brake.
 - Remove the key from ignition.

Maintenance

- Before servicing or making adjustments to the machine, stop the engine, set the parking brake, and remove the key from ignition to prevent accidental starting of the engine.
- Never work under a raised bed without placing the bed safety support on the fully extended cylinder rod.
- Make sure all hydraulic line connectors are tight, and all hydraulic hoses and lines are in good condition before applying pressure to the system.
- Keep your body and hands away from pin hole leaks or nozzles that eject hydraulic fluid under high pressure. Use paper or cardboard, not hands, to search for leaks. Hydraulic fluid escaping under pressure can have sufficient force to penetrate skin and do serious damage. If fluid is injected into the skin it must be surgically removed within a few hours by a doctor familiar with this form of injury or gangrene may result.

- Before disconnecting or performing any work on the hydraulic system, all pressure in the system must be relieved by stopping the engine, cycling the dump valve from raise to lower and/or lowering box and attachments. Place the remote hydraulics lever in the float position. If the box must be in raised position, secure it with the safety support.
- To make sure the entire machine is in good condition, keep all nuts, bolts, and screws properly tightened.
- To reduce the potential fire hazard, keep the engine area free of excessive grease, grass, leaves, and accumulation of dirt.
- If the engine must be running to perform a maintenance adjustment, keep hands, feet, clothing, and any parts of the body away from the engine and any moving parts. Keep everyone away.
- Do not overspeed the engine by changing the governor settings. The maximum engine speed is 3650 RPM. To

ensure safety and accuracy, have an Authorized Toro Distributor check the maximum engine speed with a tachometer.

- If major repairs are ever needed or assistance is required, contact an Authorized Toro Distributor.
- To be sure of optimum performance and safety, always purchase genuine Toro replacement parts and accessories. Replacement parts and accessories made by other manufacturers could be dangerous. Altering this machine in any manner may affect the machine's operation, performance, durability or its use may result in injury or death. Such use could void the product warranty of The Toro® Company.
- This machine should not be modified without The Toro® Company's authorization. Direct any inquiries to The Toro® Company, Commercial Division, Vehicle Engineering Dept., 8111 Lyndale Ave. So., Bloomington, Minnesota 55420-1196. USA

Safety and Instructional Decals



Safety decals and instructions are easily visible to the operator and are located near any area of potential danger. Replace any decal that is damaged or lost.

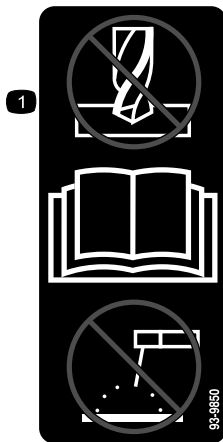

93-9850

1. Do not repair or revise—read the *Operator's Manual*.



93-9852

1. Warning—read the *Operator's Manual*.
2. Crushing hazard—install the cylinder lock.

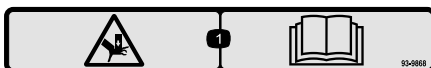

93-9868

1. Crushing hazard of hand—read the *Operator's Manual*.

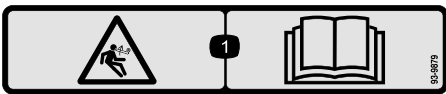

93-9879

1. Stored energy hazard—read the *Operator's Manual*.

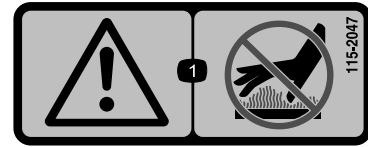

115-2047

1. Warning—do not touch the hot surface.



93-9899

1. Crushing hazard—install the cylinder lock.

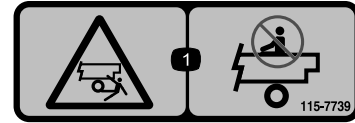

115-7739

1. Falling, crushing hazard, bystanders—no riders on machine.

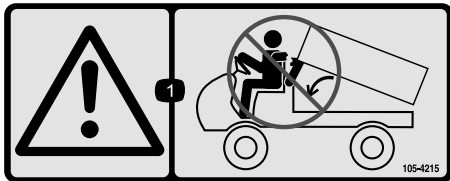

105-4215

1. Warning—avoid pinch points.

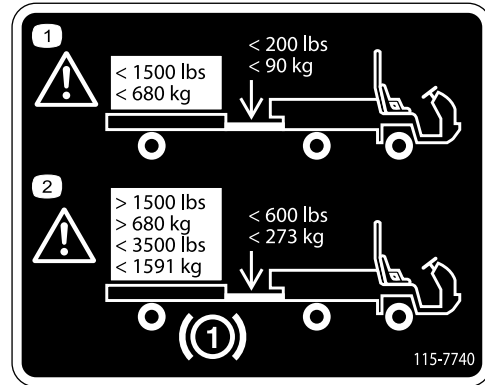

115-7740

1. Warning—maximum trailer weight is 680 kg (1500 lb), maximum tongue weight is 90 kg (200 lb).
2. Warning—trailer brakes are required when towing greater than 680 kg (1500 lb), maximum trailer weight with trailer brakes is 1591 kg (3500 lb), maximum tongue weight with trailer brakes is 273 kg (600 lb).

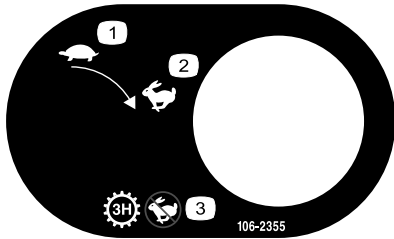

106-2355

1. Slow
2. Fast
3. Transmission—third high; no fast speed

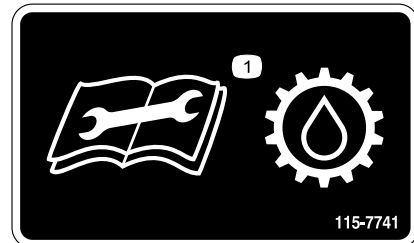

115-7741

1. Read the *Operator's Manual* before servicing transmission fluid.

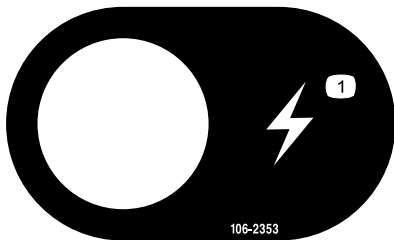

106-2353

1. Electrical power point



Battery Symbols

Some or all of these symbols are on your battery

- | | |
|--|--|
| 1. Explosion hazard | 6. Keep bystanders a safe distance from the battery. |
| 2. No fire, open flame, or smoking. | 7. Wear eye protection; explosive gases can cause blindness and other injuries |
| 3. Caustic liquid/chemical burn hazard | 8. Battery acid can cause blindness or severe burns. |
| 4. Wear eye protection | 9. Flush eyes immediately with water and get medical help fast. |
| 5. Read the <i>Operator's Manual</i> . | 10. Contains lead; do not discard. |

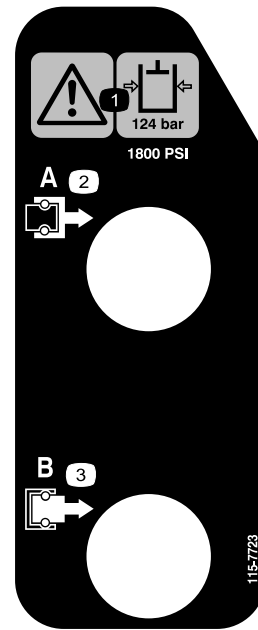

115-7723

1. Warning—the hydraulic oil pressure is 124 bar (1800 psi).
2. Coupler A
3. Coupler B



106-7767

1. Warning—read the *Operator's Manual*; avoid tipping the machine; wear the seat belt; lean away from the direction the machine is tipping.



115-2282

1. Warning—read the *Operator's Manual*.
2. Warning—stay away from moving parts, keep all guards and shields in place.
3. Crushing/dismemberment hazard of bystanders—keep bystanders a safe distance from the vehicle, do not carry passengers in the cargo bed, keep arms and legs inside of the vehicle at all times, and use seat belts and handholds.

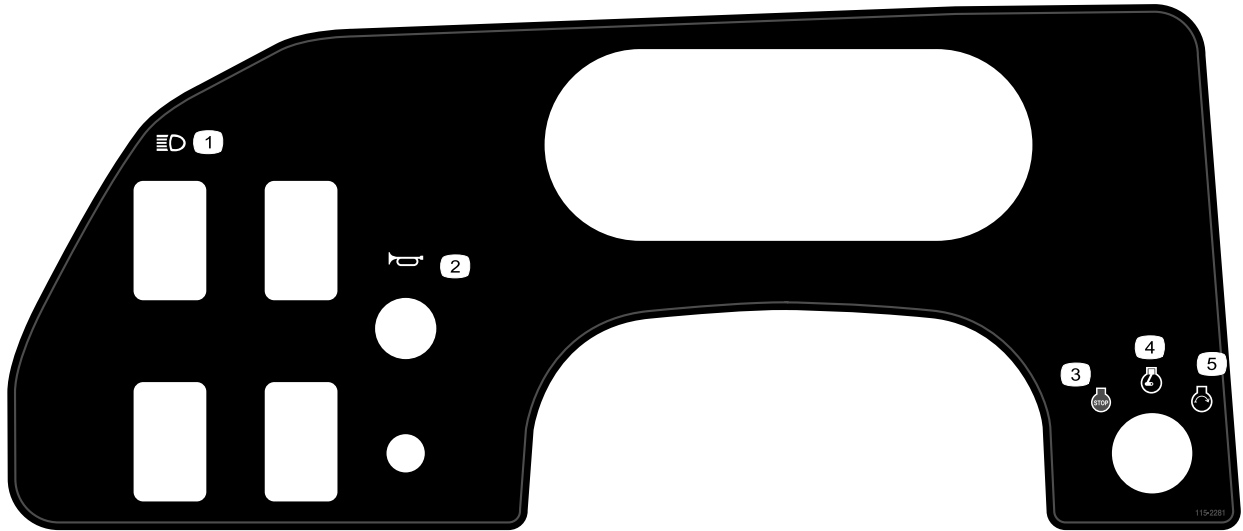

115-2281

- | | |
|--|--|
| <ol style="list-style-type: none"> 1. Headlights 2. Horn 3. Engine—stop | <ol style="list-style-type: none"> 4. Engine—run 5. Engine—start |
|--|--|

CALIFORNIA SPARK ARRESTER WARNING

Operation of this equipment may create sparks that can start fires around dry vegetation. A spark arrester may be required. The operator should contact local fire agencies for laws or regulations relating to fire prevention requirements. 117-2718

117-2718

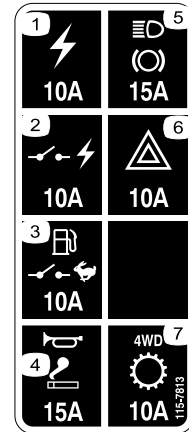

115-7813

- | | |
|---|---|
| <ol style="list-style-type: none"> 1. Power outlet—10A 2. Switched power—10A 3. Fuel pump, supervisor switch—10A 4. Horn, power point—15A | <ol style="list-style-type: none"> 5. Lights, brake—15A 6. Hazard—10A 7. 4WD, Transmission—10A |
|---|---|

WORKMAN QUICK REFERENCE AID

CHECK/SERVICE

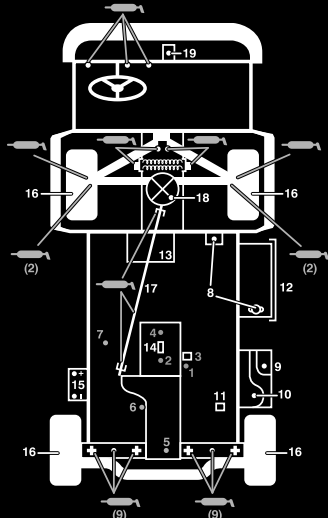

1. ENGINE OIL DIP STICK
2. ENGINE OIL DRAIN
3. ENGINE OIL FILTER
4. ENGINE OIL FILL
5. HYDRAULIC OIL DIP STICK
6. HYDRAULIC OIL STRAINER
7. HYDRAULIC OIL FILTER
8. COOLANT FILL
9. FUEL
10. FUEL PUMP/FILTER (EFI ONLY)
11. FUEL FILTER/WATER SEPARATOR (AC GAS & DIESEL)
12. RADIATOR SCREEN
13. AIR FILTER (LCG & DIESEL)
14. AIR FILTER (AC GAS ONLY)
15. BATTERY
16. TIRE PRESSURE - 20 PSI MAX FRONT, 17 PSI MAX REAR
17. 4WD SHAFT (4WD ONLY)
18. FRONT DIFFERENTIAL FILL (4WD ONLY)
19. BRAKE FLUID

↔ GREASE POINTS (100 HRS)

FLUID SPECIFICATIONS/CHANGE INTERVALS

SEE OPERATOR'S MANUAL FOR INITIAL CHANGES	FLUID TYPE	CAPACITY		CHANGE INTERVALS	
		L	QT	FLUID	FILTER
ENGINE OIL LCG ONLY	SEE MANUAL	3.3	3.5	200 HRS.	200 HRS.
ENGINE OIL LCD ONLY		3.3	3.5	150 HRS.	150 HRS.
ENGINE OIL AC ONLY		1.9	2	100 HRS.	100 HRS.
TRANS/HYDRAULIC OIL	DEXRON III ATF	7.1	7.5	800 HRS.	800 HRS.
AIR CLEANER	CLEAN EVERY 50 HRS.			200 HRS.	
FUEL	SEE MANUAL	24.6	6.5 GAL	--	400 HRS.
FUEL PUMP	--	--	--	--	400 HRS.
COOLANT 50/50 ETHYLENE GLYCOL WATER	--	3.5	3.7	1200 HRS.	--
TRANS AXLE STRAINER	--	--	--	CLEAN 800 HRS.	
DIFFERENTIAL OIL	MOBILE 424	0.25	0.26	800 HRS.	--

FOR HEAVY DUTY OPERATION, MAINTENANCE SHOULD BE PERFORMED TWICE AS FREQUENTLY.

115-7814

115-7814



115-7746

1. Warning—do not operate this machine unless you are trained.
2. Warning—lock the parking brake, stop the engine, and remove the ignition key before leaving the machine.
3. Fire hazard—stop the engine before fueling.
4. Tipping hazard—slow down and turn gradually, use caution and drive slowly when driving on slopes, do not exceed 32 kph (20 mph), and drive slowly over rough terrain or when carrying a full or heavy load.

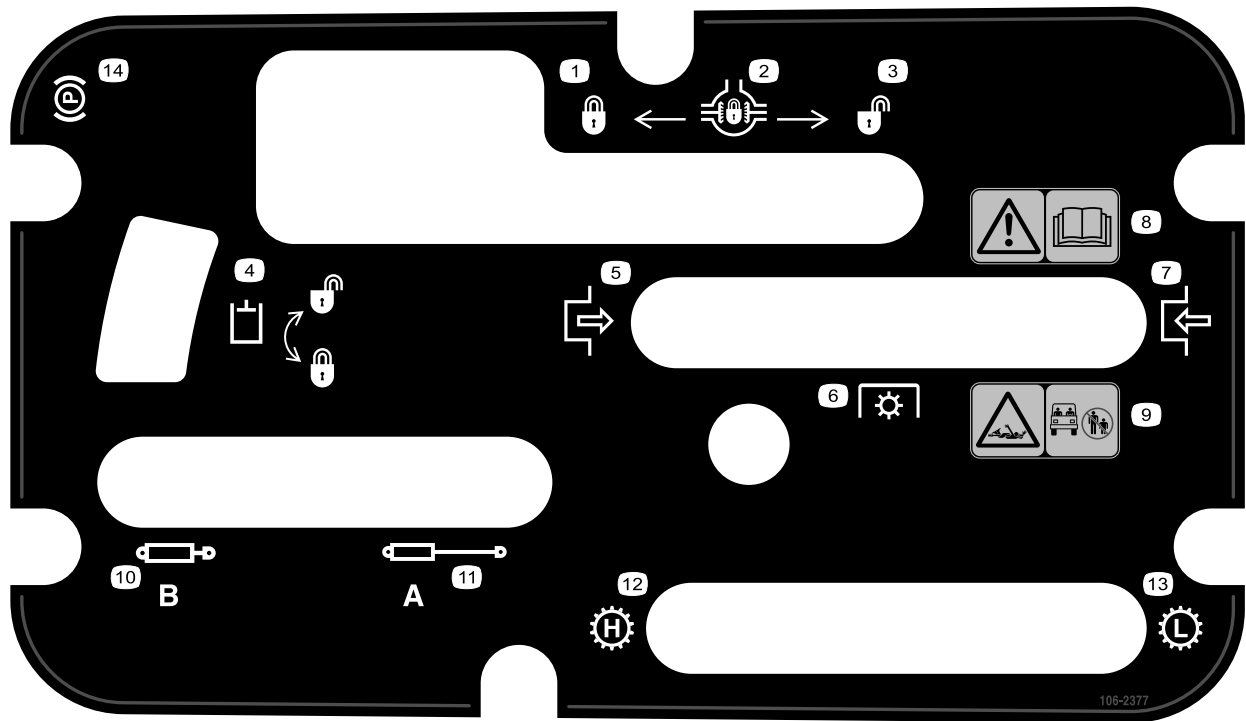

106-2377

- | | |
|---|--|
| <ol style="list-style-type: none"> 1. Locked 2. Differential lock 3. Unlocked 4. Hydraulic lock 5. Engage 6. Power take-off (PTO) 7. Disengage | <ol style="list-style-type: none"> 8. Warning—read the <i>Operator's Manual</i>. 9. Entanglement hazard, shaft—keep bystander's a safe distance from the vehicle. 10. Retract hydraulics 11. Extend hydraulics 12. Transmission—high speed 13. Transmission—low speed 14. Parking brake |
|---|--|

Setup

Loose Parts

Use the chart below to verify that all parts have been shipped.

Procedure	Description	Qty.	Use
1	No parts required	–	Check the engine oil, the transaxle/hydraulic fluid, and the brake fluid levels.
2	ROPS frame Flange-head bolt (1/2 x 1-1/4 inch)	1 6	Mount the ROPS (Rollover Protection System).

Media and Additional Parts

Description	Qty.	Use
Operator's Manual (Machine)	1	Read before operating machine
Parts Catalog	1	Use to reference part numbers
Operator Training Material	1	View before operating machine

Note: Determine the left and right side of the machine from the normal operating position.

1

Checking the Fluid Levels

No Parts Required

Procedure

1. Check the engine-oil level before and after the engine is first started; refer to [Checking the Engine Oil Level \(page 17\)](#).
2. Check the transaxle/hydraulic-fluid level before the engine is first started; refer to [Checking the Transaxle/Hydraulic Fluid Level \(page 19\)](#).
3. Check the brake-fluid level before the engine is first started; refer to [Checking the Brake-fluid Level \(page 21\)](#).

2

Installing the ROPS

Parts needed for this procedure:

1	ROPS frame
6	Flange-head bolt (1/2 x 1-1/4 inch)

Procedure

1. Apply medium-grade (service-removable) thread locking compound to the threads of the 6 flange-head bolts (1/2 x 1-1/4 inch).
2. Align each side of the ROPS with the mounting holes on each side of frame of the machine as shown in [Figure 3](#).

Product Overview

Controls

Note: Determine the left and right sides of the machine from the normal operating position.

Accelerator Pedal

The accelerator pedal (Figure 4) gives the operator the ability to vary the engine and ground speed of the machine when the transmission is in gear. Pressing the pedal increases the engine rpm and ground speed. Releasing the pedal decreases the engine rpm and ground speed of the machine.

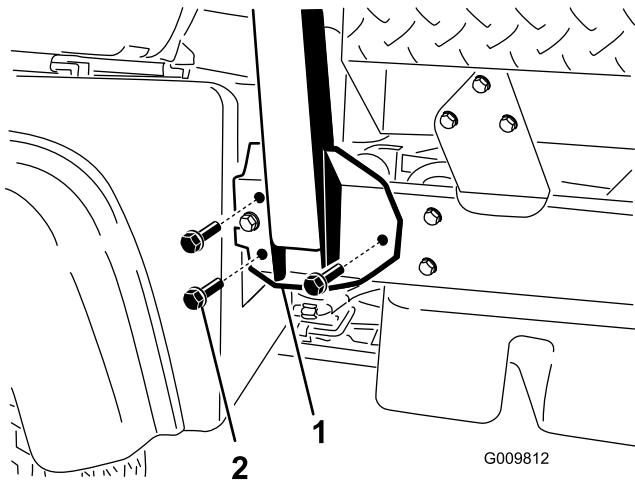

Figure 3

1. ROPS mounting bracket
2. Flange-head bolt

3. Secure each side of the ROPS mounting bracket to frame of the machine with 3 flange-head bolt (1/2 x 1-1/4 inch).
4. Torque the flange-head bolts to 115 N-m (85 ft-lb).

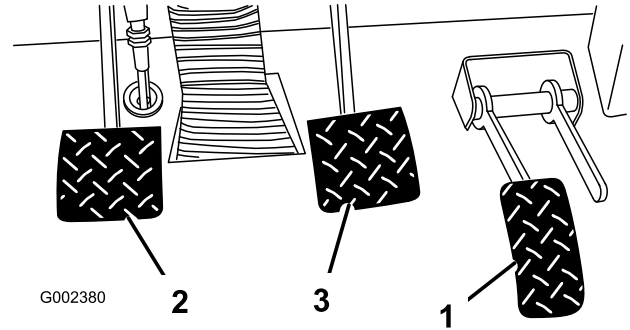

Figure 4

1. Accelerator pedal
2. Clutch pedal
3. Brake pedal

Clutch Pedal

The clutch pedal (Figure 4) must be fully pressed to disengage the clutch when starting the engine or shifting transmission gears. Release the pedal smoothly when the transmission is in gear to prevent unnecessary wear on the transmission and other related parts.

Important: Do not ride the clutch pedal during operation. The clutch pedal must be fully out or the clutch will slip causing heat and wear. Never hold the machine stopped on a hill using the clutch pedal. Damage to the clutch may occur.

Brake Pedal

The brake pedal (Figure 4) is used to apply the service brakes to stop or slow machine.

CAUTION

Worn or maladjusted brakes may result in personal injury. If the brake pedal travels to within 3.8 cm (1-1/2 inches) of the machine floor board, the brakes must be adjusted or repaired.

Gear Shift Lever

Fully press the clutch pedal and move the shift lever (Figure 6) into the desired gear selection. A diagram of the shift pattern is in Figure 5.

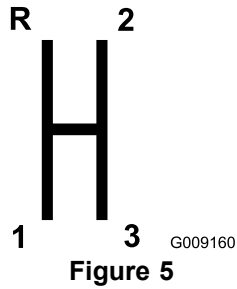

Important: Do not shift the transaxle to the reverse or forward gear unless the machine is standing still. Damage to the transaxle may occur.

⚠ CAUTION

Down shifting from too high a speed can cause the rear wheels to skid resulting in loss of machine control as well as clutch and/or transmission damage. Shift smoothly to avoid grinding gears.

Differential Lock

The differential lock allows rear axle to be locked for increased traction. The differential lock (Figure 6) may be engaged when the machine is in motion. Move the lever forward and to the right to engage the lock.

Note: Machine motion plus a slight turn is required to engage or disengage differential lock.

⚠ CAUTION

Turning with the differential lock on can result in loss of machine control. Do not operate with differential lock on when making sharp turns or at high speeds. Refer to [Using The Differential Lock \(page 25\)](#).

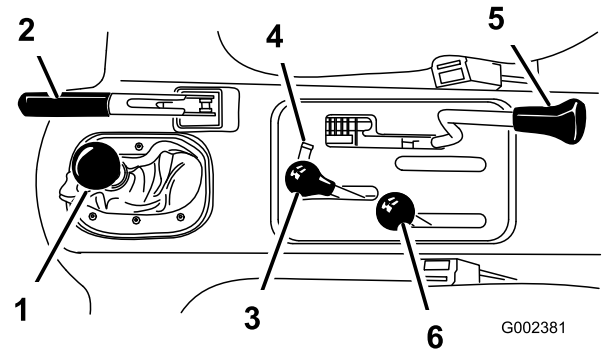

1. Gear shift lever
2. Parking brake
3. Hydraulic bed lift
4. Hydraulic lift lock
5. Differential lock
6. High-low range shifter

Parking Brake

Whenever the engine is shut off, the parking brake (Figure 6) must be engaged to prevent accidental movement of the machine. To engage the parking brake, pull back on the lever. To disengage, push the lever forward. Release the parking brake before moving the machine. If you park the machine on a steep grade, apply the parking. Also, shift the transmission into 1st gear on a uphill grade or reverse on a down hill grade. Place chocks at the down hill side of the wheels.

Hydraulic Lift

The hydraulic lift raises and lowers bed. Move it rearward to raise the bed, and forward to lower it (Figure 6).

Important: When lowering the bed, hold the lever in the forward position for 1 or 2 seconds after the bed contacts the frame to secure it in the lowered position. Do not hold the hydraulic lift in either the raise or lower position, for more than 5 seconds, once the cylinders have reached the end of their travel.

Hydraulic Lift Lock

The hydraulic lift lock locks the lift lever so the hydraulic cylinders do not operate when the machine is not equipped with a bed (Figure 6). It also locks the lift lever in the On position when using the hydraulics for attachments.

High-Low Range Shifter

The high-low range shifter adds 3 additional speeds for precise speed control (Figure 6).

- The machine must be completely stopped before shifting between High and Low range.
- Shift only on level ground.
- Press clutch pedal fully.
- Move the lever fully forward for High and fully rearward for Low.

High is for higher speed driving on level, dry surfaces with light loads.

Low is for low speed driving. Use this range when greater than normal power or control is required. For example, steep grades, difficult terrain, heavy loads, slow speed but high engine speed (spraying).

Important: There is a location between High and Low in which the transaxle is in neither range. Do not use this position as a neutral position because the machine could move unexpectedly if the High–Low shifter is bumped and the gear shift lever is in gear.

Ignition Switch

Use the ignition switch (Figure 7) to start and stop the engine. It has 3 positions: Off, Run, and Start. Rotate the key clockwise to the Start position to engage the starter motor. Release the key when the engine starts. The key will move automatically to the On position. To shut the engine off, rotate the key counterclockwise to the Off position.

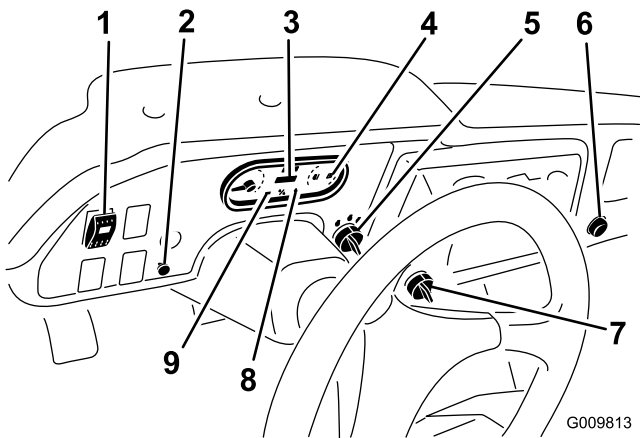

Figure 7

- | | |
|--------------------|-------------------------------|
| 1. Light switch | 6. Power point |
| 2. Choke | 7. 3rd high lockout switch |
| 3. Hour meter | 8. Oil pressure warning light |
| 4. Fuel gauge | 9. Charge indicator |
| 5. Ignition switch | |

Hour Meter

Indicates the total hours of machine operation. The hour meter (Figure 7) starts to function whenever the key switch is rotated to the On position or if the engine is running.

3rd High Lockout Switch

Move the 3rd high lockout switch (Figure 7) to the slow position and remove the key to prevent the use of third gear when in the High range. The engine will shut off if the shift lever is moved to third gear when in High range. The key is removable in either position.

Light Switch

Push the light switch (Figure 7), to toggle the headlights on or off.

Oil Pressure Warning Light

The oil pressure warning light glows (Figure 7) if the engine oil pressure drops below a safe level while the engine is running. If the light flickers or remains on, stop the machine, turn off the engine, and check the oil level. If the oil level was low, but adding oil does not cause the light to go out when the engine is restarted, turn the engine off immediately and contact your local Toro distributor for assistance.

Check the operation of warning lights as follows:

1. Apply the parking brake.
2. Turn the ignition key to the On position, but do not start the engine.

Note: The oil pressure light should glow red. If the light does not function, either a bulb is burned out or there is a malfunction in the system which must be repaired.

Note: If engine was just turned off, it may take 1 to 2 minutes for the light to come on.

Charge Indicator

Illuminates when the battery is being discharged. If the light illuminates during operation, stop the machine, turn off the engine and check for possible causes (Figure 7).

Important: If the alternator belt is loose or broken, do not operate the machine until adjustment or repair is complete. Failure to observe this precaution may result in damage to the engine.

Check the operation of warning lights as follows:

- Apply the parking brake.
- Turn the ignition key to the On position, but do not start the engine. The charge indicator and oil pressure lights should glow. If any light does not function, either a bulb is burned out or there is a malfunction in the system which must be repaired.

Fuel Gauge

The fuel gauge shows the amount of fuel in the tank. It operates only when ignition switch is in the On position (Figure 7). Red indicates low fuel level and blinking red indicates near empty.

Power Point

Use the power point (Figure 7) to power optional 12 volt electrical accessories.

Choke

To start a cold engine, close the carburetor choke by pulling the choke control (Figure 7) out to the On position. After the engine starts, regulate the choke to keep the engine running smoothly. As soon as possible, open the choke by pushing in the choke control to the Off position. A warm engine requires little or no choking.

Passenger Hand Hold

The passenger hand hold is located on the dashboard (Figure 8).

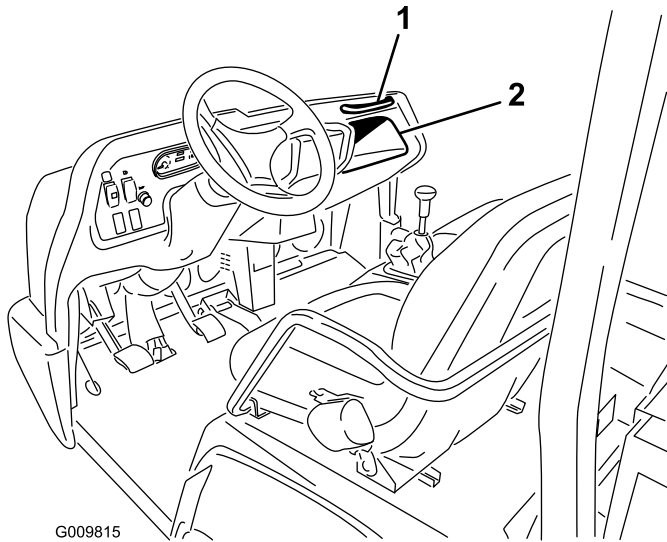

Figure 8

1. Passenger hand hold
2. Storage compartment

Seat Adjusting Lever

The seats can be adjusted fore and aft for operator comfort (Figure 9).

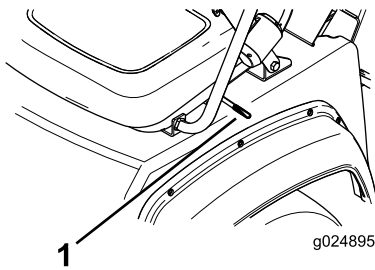

Figure 9

1. Seat adjusting lever

Specifications

Note: Specifications and design are subject to change without notice.

Dimensions

Overall Width	160 cm (63 inches)
Overall Length	w/o bed: 326 cm (128.25 inches) w/full bed: 331 cm (130.38 inches) w/2/3 bed in rear mounting location: 346 cm (136.38 inches)
Base Weight (Dry)	838 kg (1848 lb)
Rated Capacity	1361.6 kg (3002 lb) (includes 91 kg (200 lb) operator, 91 kg (200 lb) passenger, and loaded attachment).
Maximum. Gross Vehicle Weight	2359 kg (5,200 lb)
Tow Capacity	Tongue weight 272 kg (600 lb) Maximum trailer weight 1587 kg (3,500 lb)
Ground Clearance	18 cm (7 inches) w/ no load
Wheel Base	118 cm (70 inches)
Wheel Tread (center line to center line)	Front: 117 cm (46 inches) Rear: 121 cm (47.7 inches)
Height	190.5 cm (75 inches) to top of ROPS

Attachments/Accessories

A selection of Toro approved attachments and accessories is available for use with the machine to enhance and expand its capabilities. Contact your Authorized Service Dealer or Distributor or go to www.Toro.com for a list of all approved attachments and accessories.

Operation

Note: Determine the left and right sides of the machine from the normal operating position.

⚠ CAUTION

Before servicing or making adjustments to the machine, stop the engine, set the parking brake, and remove the key from the switch. Remove any load material from the bed or other attachment before working under a raised bed. Never work under a raised bed without positioning the safety support on a fully extended cylinder rod.

Operating the Cargo Box

Note: Center loads in the cargo box if possible.

Note: Remove all cargo from the box before lifting the box up to service the machine.

Raising the Cargo Box

⚠ WARNING

Driving the machine with the cargo box raised may cause the machine to tip or roll easier. The box structure may become damaged if you operate the machine with the box raised.

- Only operate the machine when the cargo box is down.
- After emptying the cargo box, lower it.

Move the lever backward to raise the cargo box (Figure 10).

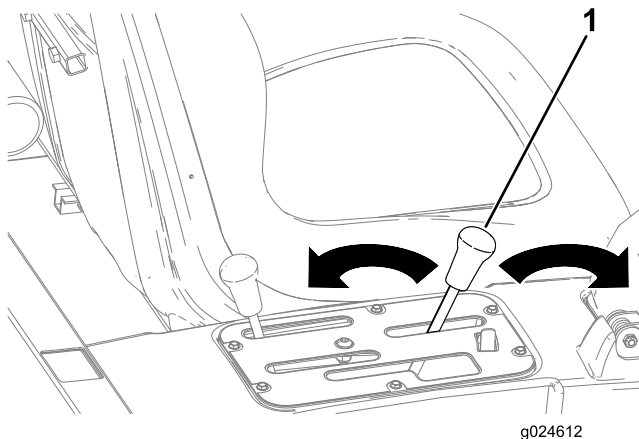

Figure 10

1. Cargo box lever

Lowering the Box

⚠ WARNING

The weight of the box may be heavy. Hands or other body parts could be crushed.

Keep hands and other body parts clear when lowering the box.

Move the lever forward to lower the cargo box (Figure 10).

Opening the Tailgate

1. Ensure that the cargo box is lowered completely.
2. Open the latches on the left and right side of the cargo box and lower the tailgate (Figure 11).

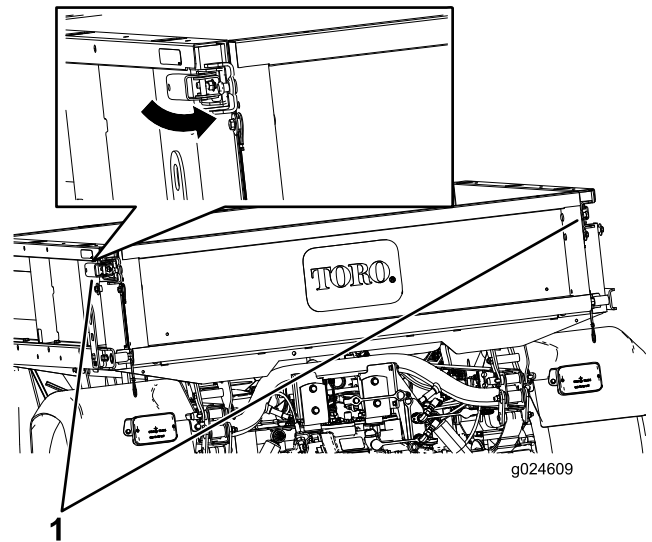

Figure 11

1. Latches

Checking the Engine Oil Level

Service Interval: Before each use or daily

The engine is shipped with approximately 1.9 L (2 quarts) (w/ filter) of oil in the crankcase; however, you should check the oil level before and after the engine is first started.

Note: The best time to check the engine oil is when the engine is cool before it has been started for the day. If it has already been run, allow the oil to drain back down to the sump for at least 10 minutes before checking. If the oil level is at or below the Add mark on the dipstick, add oil to bring the oil level to the Full mark. **Do not overfill.** If the oil level is between the Full and Add marks, no additional oil is required.

The engine uses any high-quality detergent oil having the American Petroleum Institute (API) service classification SH, SJ, or higher. Oil viscosity (weight) is selected according to anticipated ambient temperature.

Temperature/ viscosity recommendations are as follows:

- Above -20 degrees C (0 degrees F)—Use 10W-30.
- Below 0 degrees C (32 degrees F)—Use SAE 5W-30.

Note: SAE 10W-40 and straight weight oils (SAE 30, etc.) are not recommended in Kohler® engines due to problems with pump-up of hydraulic lifters with those oils. Either synthetic or mineral based oils may be used, but oil drain intervals should be the same (per recommendations).

1. Position the machine on a level surface.
2. Remove the dipstick (Figure 12) and wipe it with a clean rag.

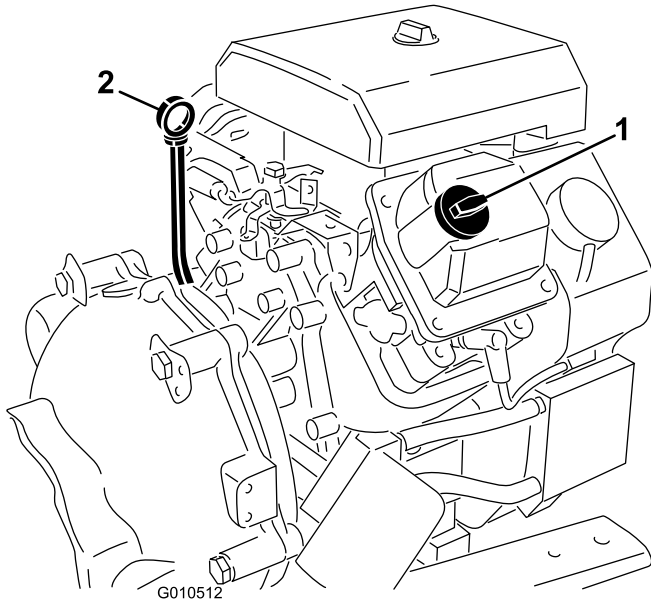

Figure 12

1. Filler Cap
2. Dipstick

3. Insert the dipstick into the tube and make sure it is seated fully.
4. Remove the dipstick and check the oil level.
5. If the oil level is low, remove the filler cap (Figure 12) and add enough oil to raise the level to the Full mark on the dipstick.

Note: When adding oil, remove dipstick to allow proper venting. Pour oil slowly and check the level often during this process. **Do not overfill.**

Important: When adding engine oil or filling oil, there must be clearance between the oil fill device and the oil fill hole in the valve cover as shown in Figure 13. This clearance is necessary to permit venting when filling, which prevents oil from overrunning into the breather.

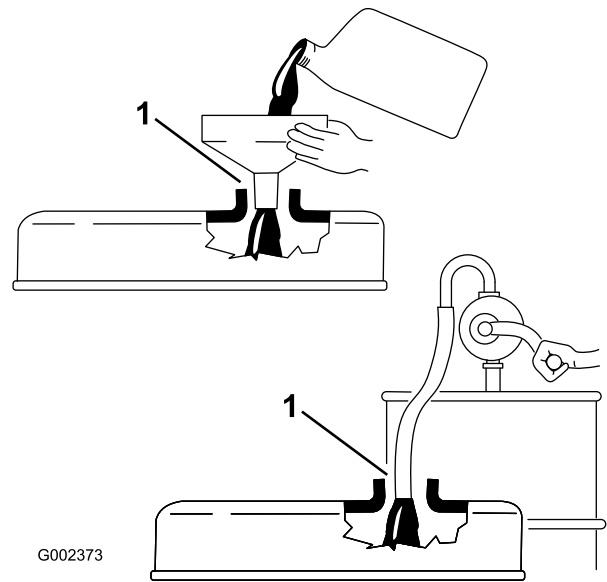

Figure 13

1. Note clearance

6. Install the dipstick firmly in place.

Adding Fuel

Fuel tank capacity: 25 L (6.5 US gallons).

- For best results, use only clean, fresh (less than 30 days old), unleaded gasoline with an octane rating of 87 or higher ((R+M)/2 rating method).
- **Ethanol:** Gasoline with up to 10% ethanol (gasohol) or 15% MTBE (methyl tertiary butyl ether) by volume is acceptable. Ethanol and MTBE are not the same. Gasoline with 15% ethanol (E15) by volume is not approved for use. **Never use gasoline that contains more than 10% ethanol by volume**, such as E15 (contains 15% ethanol), E20 (contains 20% ethanol), or E85 (contains up to 85% ethanol). Using unapproved gasoline may cause performance problems and/or engine damage which may not be covered under warranty.
- **Do not** use gasoline containing methanol.
- **Do not** store fuel either in the fuel tank or fuel containers over the winter unless a fuel stabilizer is used.
- **Do not** add oil to gasoline.

⚠ DANGER

In certain conditions, gasoline is extremely flammable and highly explosive. A fire or explosion from gasoline can burn you and others and can damage property.

- Fill the fuel tank outdoors, in an open area, when the engine is cold. Wipe up any gasoline that spills.
- Never fill the fuel tank inside an enclosed trailer.
- Do not fill the fuel tank completely full. Add gasoline to the fuel tank until the level is 6 to 13 mm (1/4 to 1/2 inch) below the bottom of the filler neck. This empty space in the tank allows gasoline to expand.
- Never smoke when handling gasoline, and stay away from an open flame or where gasoline fumes may be ignited by a spark.
- Store gasoline in an approved container and keep it out of the reach of children. Never buy more than a 30-day supply of gasoline.
- Do not operate without entire exhaust system in place and in proper working condition.

⚠ DANGER

In certain conditions during fueling, static electricity can be released causing a spark which can ignite the gasoline vapors. A fire or explosion from gasoline can burn you and others and can damage property.

- Always place gasoline containers on the ground away from your vehicle before filling.
- Do not fill gasoline containers inside a vehicle or on a truck or trailer bed because interior carpets or plastic truck bed liners may insulate the container and slow the loss of any static charge.
- When practical, remove gas-powered equipment from the truck or trailer and refuel the equipment with its wheels on the ground.
- If this is not possible, then refuel such equipment on a truck or trailer from a portable container, rather than from a gasoline dispenser nozzle.
- If a gasoline dispenser nozzle must be used, keep the nozzle in contact with the rim of the fuel tank or container opening at all times until fueling is complete.

⚠ WARNING

Gasoline is harmful or fatal if swallowed. Long-term exposure to vapors can cause serious injury and illness.

- Avoid prolonged breathing of vapors.
- Keep face away from nozzle and gas tank or conditioner bottle opening.
- Avoid contact with skin; wash off spillage with soap and water.

1. Clean the area around the fuel tank cap.
2. Remove the fuel tank cap (Figure 14).

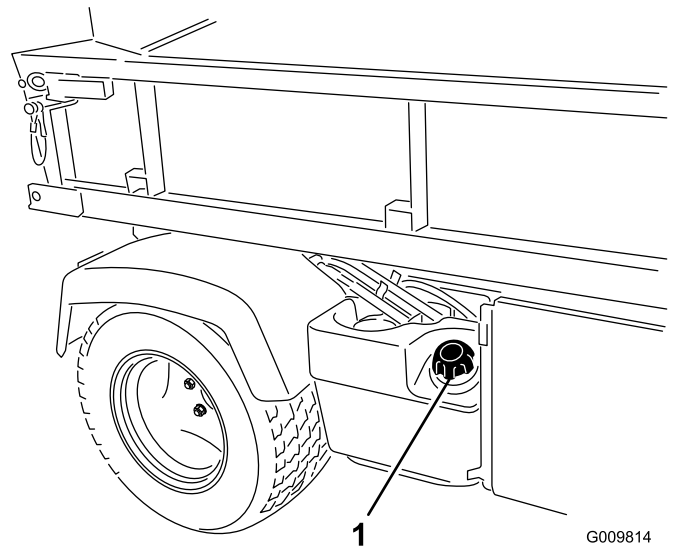

Figure 14

1. Fuel tank cap

3. Fill the tank to about one inch below the top of the tank, (bottom of the filler neck), then install the cap. **Do not overfill.**
4. Wipe up any fuel that may have spilled to prevent a fire hazard.

Checking the Transaxle/Hydraulic Fluid Level

Service Interval: Before each use or daily

The transaxle reservoir is filled with Dexron III ATF. Check the level before the engine is first started and every 8 hours or daily, thereafter. Capacity of system is .

Transaxle reservoir capacity: 7.0 L (7.5 qt).

1. Position the machine on a level surface.

- Clean the area around the dipstick (Figure 15).

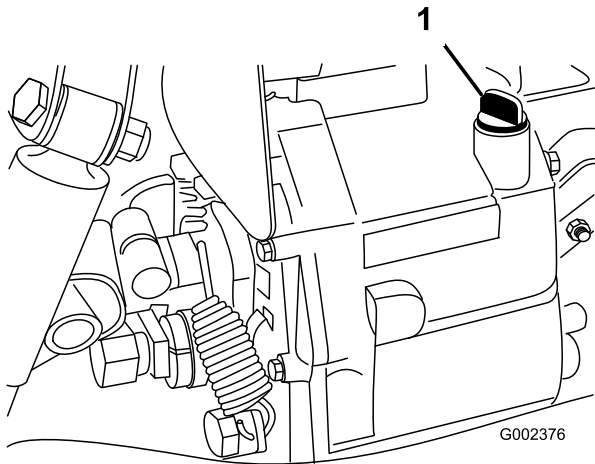

Figure 15

- Dipstick

- Unscrew the dipstick from the top of the transaxle and wipe it with a clean rag.
- Screw the dipstick into the transaxle and ensure that it is fully seated.
- Unscrew the dipstick and check the fluid level.
The fluid should be up to top of the flat portion of the dipstick.
- If the level is low, add enough fluid to achieve the proper level.

Checking the Torque of the Wheel Nuts

Service Interval: After the first 2 hours
After the first 10 hours
Every 200 hours

⚠ WARNING

Failure to maintain proper torque of the wheel nuts could result in failure or loss of a wheel and may result in personal injury.

Torque the front and rear wheel nuts to 109 to 122 N-m (80 to 90 ft-lb) after 1 to 4 hours of operation and again after 10 hours of operation. Torque every 200 hours thereafter.

Checking the Tire Pressure

Service Interval: Before each use or daily

The air pressure in the front tires is 220 kPa (32 psi) and the rear tires is 124 kPa (18 psi).

Check the tire pressure frequently to ensure proper inflation. If the tires are not inflated to the correct pressure, the tires will wear prematurely.

Figure 16 is an example of tire wear caused by under inflation.

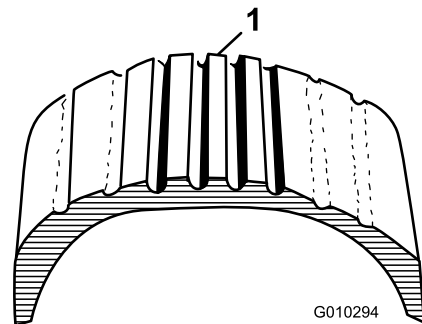

Figure 16

- Under-inflated tire

Figure 17 is an example of tire wear caused by over inflation.

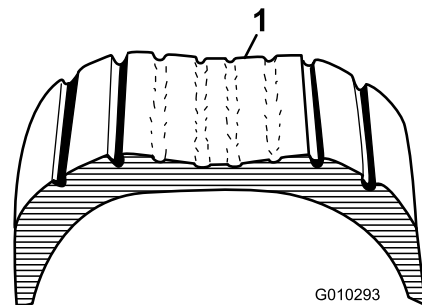

Figure 17

- Over-inflated tire

Checking the Brake-fluid Level

Service Interval: Before each use or daily—Check the brake-fluid level.

Every 1,000 hours/Every 2 years (whichever comes first)—Change the brake fluid.

The brake-fluid reservoir is shipped from the factory filled with DOT 3 brake fluid. Check the level before the engine is first started and every 8 hours or daily, thereafter.

The brake-fluid reservoir is located under the dash.

1. Park the machine on a level surface.
2. The fluid level should be up to the Full line on the reservoir (Figure 18).

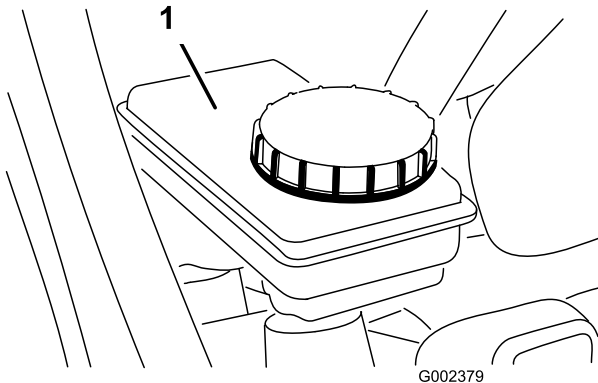

Figure 18

1. Brake-fluid reservoir

3. If the fluid level is low, clean the area around the cap, remove the reservoir cap, and fill the reservoir to the proper level.

Note: Do not overfill.

Note: You can remove the hood access to the reservoir from the front of the machine (Figure 19).

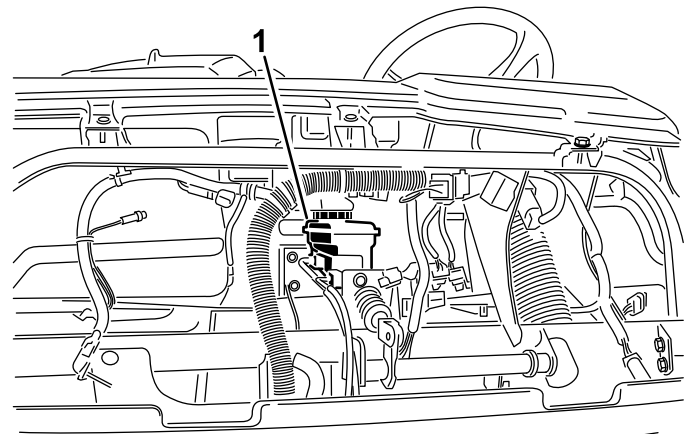

WORKMAN

G009817

Figure 19

1. Brake-fluid reservoir

Starting the Engine

1. Sit on the operator's seat and engage the parking brake.
2. Disengage the PTO (if so equipped) and move the hand throttle lever to the Off position (if so equipped).
3. Move the shift lever to the Neutral position and press the clutch pedal.
4. Ensure that the hydraulic lift lever is in the center position.
5. Do one of the following, depending on the situation:
 - If the engine is **cold**—press and hold the accelerator pedal about half way down and pull the choke knob out to the On position.
 - If the engine is **hot**—press and hold the accelerator pedal about half way down.
 - If the engine is **flooded**—fully press the accelerator pedal and hold it to the floor until the engine starts. Never pump the accelerator pedal.
6. Insert key into ignition switch and rotate it clockwise to start the engine. Release key when engine starts.

Important: To prevent overheating of the starter motor, do not engage starter longer than 15 seconds. After 15 seconds of continuous cranking, wait 60 seconds before engaging starter motor again.

7. When starting a cold engine, gradually return the choke knob to the Off position as the engine warms up.

Driving the Machine

1. Release the parking brake.
2. Fully press the clutch pedal.
3. Move the gear shift lever to 1st gear.
4. Release the clutch pedal smoothly while pressing the accelerator pedal.
5. When the machine gains enough speed, remove your foot from the accelerator pedal, fully press the clutch pedal, move the gear shift lever to the next gear and release the clutch pedal while pressing the accelerator pedal. Repeat the procedure until the desired speed is attained.

Important: Always stop the machine before shifting to reverse from a forward gear or to a forward gear from reverse.

Note: Avoid long periods of engine idling.

Use the chart below to determine the ground speed of the machine at 3600 RPM.

Gear	Range	Ratio	Speed (mph)	Speed (kmh)
1	L	82.83 : 1	2.9	4.7
2	L	54.52 : 1	4.5	7.2
3	L	31.56 : 1	7.7	12.5
1	H	32.31 : 1	7.6	12.2
2	H	21.27 : 1	11.5	18.5
3	H	12.31 : 1	19.8	31.9
R	L	86.94 : 1	2.8	4.5
R	H	33.91 : 1	7.1	11.6

Note: Leaving ignition switch in the On position for long periods of time without running the engine will discharge the battery.

Important: Do not attempt to push or tow the machine to get it started. Damage to the drive train could result.

Stopping the Machine

To stop the machine, remove your foot from the accelerator pedal, press the clutch pedal, then press the brake pedal.

Stopping the Engine

To stop the engine, rotate the ignition key to the Off position and engage the parking brake. Remove the key from the switch to prevent accidental starting.

Breaking in a New Machine

To provide proper performance and long machine life, follow these guidelines for the first 100 operating hours.

- Check the fluid and engine oil levels regularly and be alert for indications of overheating in any component of the machine.
- After starting a cold engine, let it warm up for about 15 seconds before shifting into gear.
- Avoid racing the engine.
- To ensure optimum performance of the brake system, burnish (break-in) the brakes before use. To burnish the brakes, bring the vehicle up to full speed, apply the brakes to rapidly stop the vehicle without locking up the tires. Repeat this 10 times, waiting 1 minute between stops to avoid overheating the brakes. This is most effective if the machine is loaded with 454 kg (1000 lb).
- Vary the machine speed during operation. Avoid excessive idling. Avoid fast starts and quick stops.
- A break-in oil for the engine is not required. The original engine oil is the same type specified for regular oil changes.
- Refer to the Maintenance section for any special low hour checks.

Checking the Safety-interlock System

Service Interval: Before each use or daily

The purpose of the safety-interlock system is to prevent the engine from cranking or starting unless the clutch pedal is pressed.

⚠ CAUTION

If the safety-interlock switches are disconnected or damaged the machine could operate unexpectedly causing personal injury.

- Do not tamper with the interlock switches.
- Check the operation of the interlock switches daily and replace any damaged switches before operating the machine.

Note: Refer to *Attachment Operator's Manual* for procedures on checking the attachment interlock system.

Verifying the Clutch Interlock Switch

1. Sit on the operator's seat and engage the parking brake.
2. Move the shift lever to the Neutral position.
Note: The engine will not crank if the hydraulic-lift lever is locked in the forward position.
3. Without pressing the clutch pedal, rotate the ignition key clockwise to the Start position.

Note: If the engine cranks or starts, there is a malfunction in the interlock system that must be repaired before operating the machine.

Verifying the Hydraulic-lift Lever Interlock Switch

1. Sit on the operator's seat and engage the parking brake.
2. Move the shift lever to the Neutral position and ensure that the hydraulic-lift lever is in the center position.
3. Press clutch pedal.
4. Move the hydraulic-lift lever forward and rotate the ignition key clockwise to the start position.

Note: If engine cranks or starts, there is a malfunction in the interlock system that must be repaired before operating the machine.

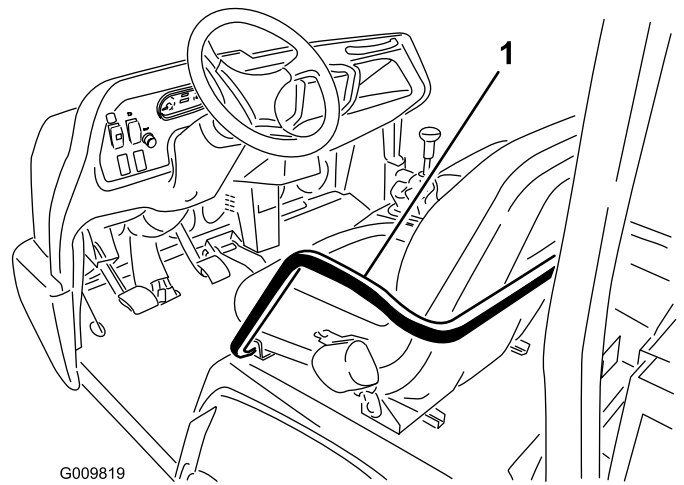

Figure 21

1. Hand hold & hip restraint

Ensuring Passenger Safety

Whenever you have a passenger riding in the machine make sure he or she is wearing the seat belt and holding on securely. Drive slower and turn less sharply because your passenger does not know what you are going to do next and may not be prepared for turning, stopping, accelerating, and bumps.

You and your passenger should remain seated at all times, keeping arms and legs inside the machine. The operator should keep both hands on steering wheel, whenever possible, and the passenger should use the hand holds provided (Figure 20 & Figure 21).

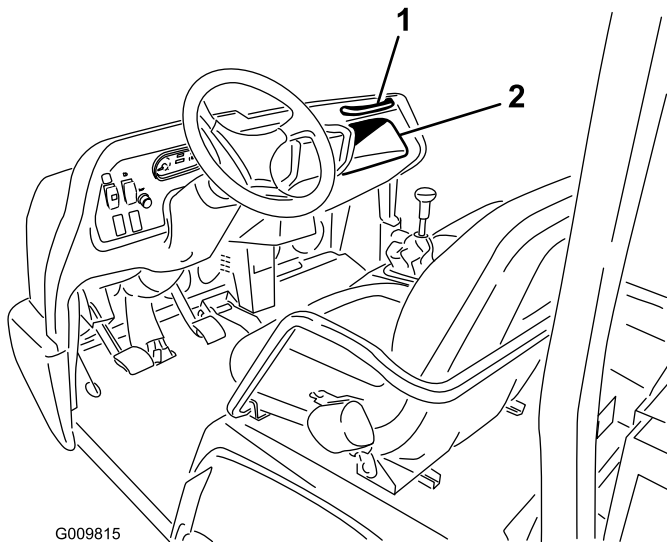

Figure 20

1. Passenger hand hold
2. Storage compartment

Never allow passengers in the dump box or on any attachments. The machine is meant to have one driver and only one passenger—no more.

Ensuring Proper Speed

Speed is one of the most important variables leading to accidents. Driving too fast for the conditions can cause you to lose control and have an accident. Speed can also make a minor accident worse. Driving head-on into a tree at slow speed can cause injury and damage, but, driving into a tree at high speed can destroy the machine and kill you and your passenger.

Never drive too fast for the conditions. If there is any doubt about how fast to drive, slow down.

When using heavy attachments, more than 454 kg (1000 lb), such as sprayers, top dressers, or spreaders, etc., restrict your operating speed by moving the 3rd high lockout switch to the slow position.

Ensuring Proper Turning

Turning is another important variable leading to accidents. Turning too sharply for the conditions can cause the machine to lose traction and skid, or even tip over.

Wet, sandy, and slippery surfaces make turning more difficult and risky. The faster you are going, the worse this situation becomes so, slow down before turning.

During a sharp turn at higher speeds, the inside rear wheel may lift off of the ground. This is not a flaw in the design, it happens with most four wheel machines including passenger cars. If this happens, you are turning too sharply for the speed at which you are traveling. **Slow down!**

Ensuring Proper Braking

It is good practice to slow down before you get near an obstacle. This gives you extra time to stop or turn away. Hitting an obstacle can damage the machine and its contents. More important, it can injure you and your passenger. Gross machine weight has a major impact on your ability to stop and/or turn. Heavier loads and heavier attachments make a machine harder to stop or turn. The heavier the load, the longer it takes to stop.

The braking characteristics also change with no bed or attachment on the machine. Fast stops may cause the rear wheels to lock up before the front wheels lock up, which may affect the control of the machine. It is a good idea to decrease machine speed with no bed or attachment.

Turf and pavement are much slipperier when they are wet. It can take 2 to 4 times as long to stop on wet surfaces as on dry surfaces.

If you drive through standing water deep enough to get the brakes wet, they will not work well until they are dry. After driving through water, you should test the brakes to make sure they work properly. If they do not, drive slowly in first gear while putting light pressure on the brake pedal. This will dry the brakes out.

Do not downshift for braking on icy or slippery surfaces (wet grass) or while going down a hill because engine braking may cause skidding and loss of control. Shift to a lower gear before starting down a hill.

Preventing Tip Overs

The machine is equipped with a roll bar, hip restraints, seat belts, and hand hold. The ROPS system (Rollover Protection System) used on the machine will reduce the risk of serious or fatal injury in the unlikely event of a tip over, although the system cannot protect the operator from all possible injuries.

Replace a damaged ROPS, do not repair or revise. Any alteration of the ROPS must be approved by the manufacturer.

The best way to prevent accidents involving utility machines is through continuous supervision and training of operators and paying constant attention to the area in which machine is being operated.

The best way for operators to prevent serious injury or death to themselves or others, is to familiarize themselves with the proper operation of the utility machine, to stay alert and to avoid actions or conditions which could result in an accident. In the event of a tip over, the risk of serious injury or death will be reduced if the operator is using the ROPS system and seat belts and is following the instructions provided.

Operating on Hills

▲ WARNING

Tipping or rolling the machine on a hill will cause serious personal injury.

- Do not operate the machine on steep slopes.
- If engine stalls or you lose headway on a hill, never attempt to turn machine around.
- Always back straight down a hill in reverse gear.
- Never back down in neutral or with the clutch depressed, using only the brakes.
- Never drive across a steep hill, always drive straight up or down.
- Avoid turning on a hill.
- Don't "drop the clutch" or slam on the brakes. Sudden speed change can initiate a tip over.

Use extra care when on hills. Never go on hills that are extremely steep. Stopping while going down a hill will take longer than on level ground. Turning while going up or down a hill is more dangerous than turning on the level. Turns while going down hill, especially with the brakes on, and, turning up hill while traversing a hill are particularly dangerous. Even at a slow speed and without a load, tip overs are more likely if you turn on a hill.

Slow down and shift into a lower gear before starting up or down a hill. If you have to turn while on a hill, do it as slowly and cautiously as possible. Never make sharp or fast turns on a hill.

If you stall or begin to lose headway while climbing a steep hill, quickly apply the brakes, shift to neutral, restart the engine and shift to reverse. At idle speed, the engine and transaxle drag will aid the brakes in controlling the machine on the hill and help you back down the hill more safely.

Reduce the weight of the load if it is a steep hill or if the load has high center of gravity. Remember, loads can shift, secure them.

Note: The machine has excellent hill climbing ability. The differential lock will increase this ability. Hill climbing traction can also be increased by adding weight to the rear of the machine in one of the following ways:

- Adding weight to inside of box, making sure it is secured.
- Mounting wheel weights to rear wheels.
- Adding liquid ballast (calcium chloride) to rear tires.
- Traction will increase with no passenger in front seat.

Loading and Dumping

The weight and position of the cargo and passenger can change the machine center of gravity and machine handling. To avoid loss of control resulting in personal injury, follow these guidelines.

Do not carry loads which exceed the load limits described on the machine weight label.

▲ WARNING

The bed will lower whenever the dump lever is pushed down, even when the engine is off. Turning off the engine will *not* prevent the box from lowering. Always place the safety support on the extended lift cylinder to hold the box up if you are not going to lower it right away.

The machine has several combinations of boxes, platforms, and attachments available. These can be used in various combinations that allow for maximum capacity and versatility. The full sized box is 140 cm (55 inches) wide by 165 cm (65 inches) long and can hold up to 1360 kg (3000 lb) of evenly distributed cargo.

Loads vary in how they are distributed. Sand spreads out evenly and quite low. Other items, such as bricks, fertilizer or landscape timbers, stack higher in the box.

The height and weight of the load has a significant influence on tip overs. The higher a load is stacked, the more likely the machine is to tip over. You may find that 1360 kg (3000 lb) stacks too high for safe operation. Reducing the total weight is one way to reduce the risk of a tip over. Distributing the load as low as possible is another way to reduce the risk of a tip over.

If the load is positioned toward one of the sides, it will make the machine much more likely to tip over on that side. This is especially true when turning if the load is on the outside of the turn.

Never position heavy loads behind the rear axle. If the load is positioned so far to the rear that it is behind the rear axle, it will reduce the weight on the front wheels and this will reduce steering traction. With the load all the way to the back, the front wheels can even come off of the ground when going over bumps or up a hill. This will result in a loss of steering and may lead to the machine tipping over.

As a general rule, position the weight of the load evenly from front to rear and evenly from side to side.

If a load is not secured, or you are transporting a liquid in a large container such as a sprayer, it can shift. This shifting happens most often while turning, going up or down hills, suddenly changing speeds, or while driving over rough surfaces. Shifting loads can lead to tip overs. Always secure loads so that they do not shift. Never dump the load while the machine is sideways on the hill.

Heavy loads increase stopping distance and reduce your ability to turn quickly without tipping over.

The rear cargo space is intended for load carrying purposes only, not for passengers.

Using The Differential Lock

The differential lock increases the machine's traction by locking the rear wheels so one wheel will not spin out. This can help when you have heavy loads to haul on wet turf or slippery areas, going up hills, and on sandy surfaces. It is important to remember however, that this extra traction is only for temporary limited use. Its use does not replace the safe operation, already discussed concerning steep hills and heavy loads.

The differential lock causes the rear wheels to spin at the same speed. When using differential lock your ability to make sharp turns is somewhat restricted and may scuff the turf. Use the differential lock only when needed, at slower speeds and only in first or second gear.

▲ WARNING

Tipping or rolling the machine on a hill will cause serious injury.

- **The extra traction available with the differential lock can be enough to get you into dangerous situations such as climbing slopes that are too steep to turn around. Be extra careful when operating with the differential lock on, especially on steeper slopes.**
- **If the differential lock is on when making a sharp turn at a higher speed and the inside rear wheel lifts off the ground, there may be a loss of control which could cause machine to skid. Use the differential lock only at slower speeds.**

Transporting the Machine

For moving the machine long distances, use a trailer. Make sure the machine is secured to the trailer. Refer to [Figure 22](#) & [Figure 23](#) for the location of the tie down points.

Important: Trailers weighing over 680 kg (1500 lb) are required to be equipped with trailer brakes.

Important: Load the machine on the trailer with the front of the machine facing forward. If that is not possible, secure the machine hood to the frame with a strap, or remove the hood and transport and secure it separately or the hood may blow off during transport.

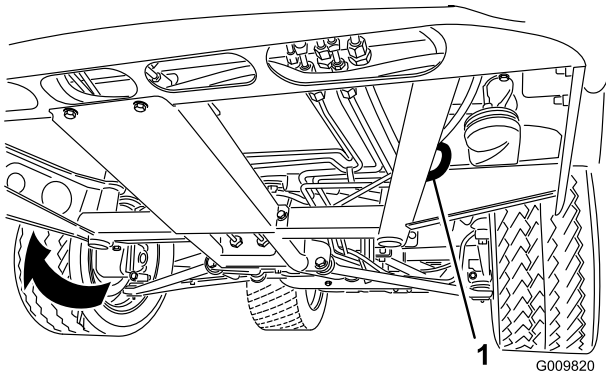

Figure 22

1. Eye hole in frame (each side)

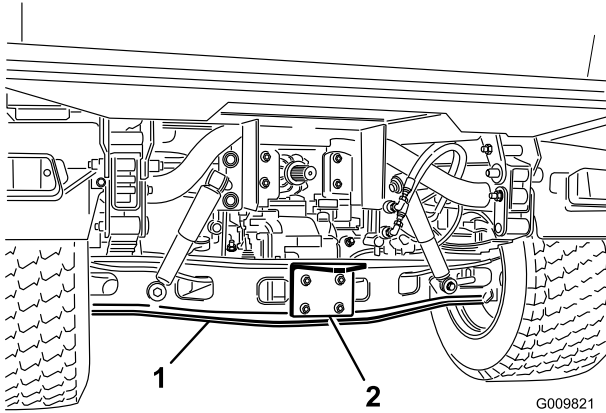

Figure 23

1. Axle
2. Hitch plate

Towing the Machine

In case of an emergency, the machine can be towed for a short distance. However, Toro does not recommend this as a standard procedure.

▲ WARNING

Towing at excessive speeds could cause machine to lose steering control. Never tow machine faster than 8 kph (5 mph).

Towing the machine is a two person job. Affix a tow line to holes in the front frame member. Move the shifter to Neutral and release the parking brake. If the machine must be moved a considerable distance, transport it on a truck or trailer.

Note: The power steering will not function, making it difficult (increased effort) to steer.

Towing a Trailer with the Machine

The machine is capable of pulling trailers and attachments of greater weight than the machine itself.

Several types of tow hitches are available for the Workman, depending on your application. Contact your Authorized Toro Distributor for details.

When equipped with a tow hitch bolted onto the rear axle tube, your Workman can tow trailers or attachments with a Gross Trailer Weight (GTW) up to 1587 kg (3500 lb). Always load a trailer with 60% of the cargo weight in the front of the trailer. This places approximately 10% (272 kg (600 lb) max.) of the Gross Trailer Weight (GTW) on the tow hitch of the machine.

Trailer brakes are required whenever you tow a trailer over 680 kg (1500 lb) GTW is towed behind a machine.

When hauling cargo or towing a trailer (attachment), do not overload your machine or trailer. Overloading can cause poor performance or damage to the brakes, axle, engine, transaxle, steering, suspension, body structure, or tires.

Important: To reduce potential for drive line damage, use low range.

When towing 5th wheel attachments, like a fairway aerator, always install the wheely bar (included with the 5th wheel kit) to prevent the front wheels from lifting off the ground if the towed attachments movement is suddenly impaired.

Using the Hydraulic Control

The hydraulic control supplies hydraulic power from the machine pump whenever the engine is running. The power can be used through the quick couplers at the rear of the machine.

Important: If multiple machines use the same attachment, cross contamination of the transmission fluid may occur. Change the transmission fluid more frequently

Control Lever Positions

- Off Position

This is the normal position for the control valve when it is not being used. In this position the work ports of the control valve are blocked and any load will be held by the check valves in both directions.

- Raise (Quick Coupler “A” Position)

This is the position which will lift the bed, rear hitch attachment or apply pressure to quick coupler A. This also allows return oil from quick coupler B to flow back into the valve and then out to the reservoir. This is a momentary position and when the lever is released it spring returns to the center off position.

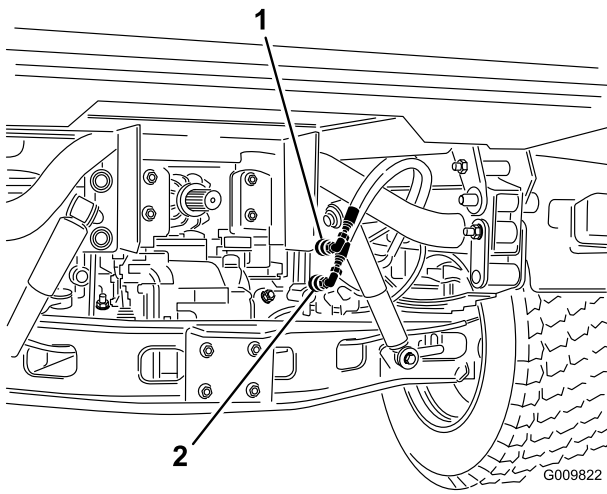

Figure 24

1. Quick coupler A position 2. Quick coupler B position

- Lower (Quick Coupler B Position)

This position will lower the bed, rear hitch attachment, or apply pressure to quick coupler B. This also allows return oil from quick coupler A to flow back into the valve and then out to the reservoir. This is a momentary position and when the lever is released it spring returns to the center off position. Momentarily holding and then releasing the control lever in this position will provide flow to quick coupler B which provides power down on the rear hitch. When released, it will hold the down pressure on the hitch.

Important: If used with a hydraulic cylinder, holding the control lever in the lower position causes the oil flow to go over a relief valve which can damage the hydraulic system.

- On Position

This position is similar to Lower (quick coupler B position). It also directs oil to quick coupler B except that the lever is held in this position by a detent lever in the control panel. This allows oil to flow continuously to equipment that uses a hydraulic motor. This position must only be used on attachments with a hydraulic motor attached.

Important: If used with a hydraulic cylinder or no attachment, the On position causes the oil flow to go over a relief valve which can damage the hydraulic system. Use this position only momentarily or with a motor attached.

Important: Check hydraulic oil level after installation of an attachment. Check the operation of the attachment by cycling the attachment several times to purge air from system, then recheck hydraulic oil level. The attachment cylinder will slightly affect transaxle oil level. Operation of machine with low oil level can damage the pump, remote hydraulics, power steering, and the machine transaxle.

⚠ CAUTION

Hydraulic fluid escaping under pressure can have sufficient force to penetrate skin and do serious damage. Care must be used when connecting or disconnecting hydraulic quick couplers. Stop the engine, apply the parking brake, lower the attachment, and place the remote hydraulic valve in the float detent position to relieve hydraulic pressure before connecting or disconnecting quick couplers.

Connecting the Quick Couplers

Important: Clean dirt from quick couplers before connecting. Dirty couplers can introduce contamination into the hydraulic system

1. Pull back the locking ring on the coupler.
2. Insert the hose nipple into the coupler until it snaps into position.

Note: When attaching remote equipment to the quick couplers, determine which side requires pressure, then attach that hose to quick coupler B which will have pressure when the control lever is pushed forward or locked in the On position.

Disconnecting the Quick Couplers

Note: With both the machine and attachment turned off, move the lift lever back and forth to remove the system pressure and ease the disconnection of the quick couplers.

1. Pull back the locking ring on the coupler.
2. Pull the hose firmly from the coupler.

Important: Clean and install the dust plug and dust covers to the quick coupler ends when not in use.

Maintenance

Determine the left and right sides of the machine from the normal operating position.

⚠ CAUTION

Only qualified and authorized personnel shall be permitted to maintain, repair, adjust, or inspect the machine.

Avoid fire hazards and have fire protection equipment present in the work area. Do not use an open flame to check level or leakage of fuel, battery electrolyte, or coolant. Do not use open pans of fuel or flammable cleaning fluids for cleaning parts.

⚠ CAUTION

If you leave the key in the ignition switch, someone could accidentally start the engine and seriously injure you or other bystanders.

Remove the key from the ignition before you do any maintenance.

Recommended Maintenance Schedule(s)

Maintenance Service Interval	Maintenance Procedure
After the first 2 hours	<ul style="list-style-type: none">• Torque the front and rear wheel nuts.
After the first 10 hours	<ul style="list-style-type: none">• Torque the front and rear wheel nuts.• Check the adjustment of the shift cables.• Check the adjustment of the parking brake.• Check the condition and tension of the pump drive belt.• Replace the hydraulic filter.
After the first 50 hours	<ul style="list-style-type: none">• Inspect opening on filter.• Change the engine oil and filter.
Before each use or daily	<ul style="list-style-type: none">• Check engine oil level.• Check the transaxle/hydraulic fluid level.• Check the tire pressure.• Check the brake-fluid level.• Check the operation of the safety-interlock system.
Every 50 hours	<ul style="list-style-type: none">• Clean and oil the air cleaner foam pre-cleaner. (Every 25 hours if operating conditions are extremely dusty or sandy)• Inspect the air cleaner paper element.• Check the battery cable connections.
Every 100 hours	<ul style="list-style-type: none">• Grease all bearings and bushings. (Lubricate more frequently in heavy duty applications)• Change the engine oil and filter.• Check the condition of the tires.• Removing debris from the engine cooling system. (Clean more frequently in dirty conditions.)

Maintenance Service Interval	Maintenance Procedure
Every 200 hours	<ul style="list-style-type: none"> • Torque the front and rear wheel nuts • Inspect opening on filter. • Change the air cleaner paper element. • Check the adjustment of the shift cables. • Check the adjustment of the high-low cable. • Check the adjustment of the differential lock cable. • Check the adjustment of the parking brake. • Check the adjustment of the brake pedal. • Check the condition and tension of the pump drive belt. • Check the adjustment of the clutch pedal. • Check the adjustment of the accelerator. • Inspect the service and parking brakes.
Every 400 hours	<ul style="list-style-type: none"> • Replace the fuel filter. • Check the fuel lines and connections. • Check the front wheel alignment. • Visually inspect the brakes for worn brake shoes.
Every 800 hours	<ul style="list-style-type: none"> • Inspect or replace the spark plugs. • Change the hydraulic fluid and clean the strainer. • Replace the hydraulic filter.
Every 1,000 hours	<ul style="list-style-type: none"> • Change the brake fluid. • Drain/flush the fuel tank.
Yearly	<ul style="list-style-type: none"> • Complete all yearly maintenance procedures specified in the Engine Operator's Manual.

Service Interval Chart

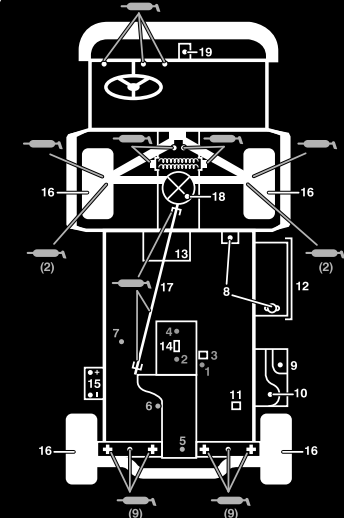

WORKMAN QUICK REFERENCE AID

CHECK/SERVICE

1. ENGINE OIL DIP STICK
2. ENGINE OIL DRAIN
3. ENGINE OIL FILTER
4. ENGINE OIL FILL
5. HYDRAULIC OIL DIP STICK
6. HYDRAULIC OIL STRAINER
7. HYDRAULIC OIL FILTER
8. COOLANT FILL
9. FUEL
10. FUEL PUMP/FILTER (EFI ONLY)
11. FUEL FILTER/WATER SEPARATOR (AC GAS & DIESEL)
12. RADIATOR SCREEN
13. AIR FILTER (LCG & DIESEL)
14. AIR FILTER (AC GAS ONLY)
15. BATTERY
16. TIRE PRESSURE - 20 PSI MAX FRONT, 17 PSI MAX REAR
17. 4WD SHAFT (4WD ONLY)
18. FRONT DIFFERENTIAL FILL (4WD ONLY)
19. BRAKE FLUID

← GREASE POINTS (100 HRS)

FLUID SPECIFICATIONS/CHANGE INTERVALS

SEE OPERATOR'S MANUAL FOR INITIAL CHANGES	FLUID TYPE	CAPACITY		CHANGE INTERVALS	
		L	QT	FLUID	FILTER
ENGINE OIL LCG ONLY	SEE MANUAL	3.3	3.5	200 HRS.	200 HRS.
ENGINE OIL LCD ONLY		3.3	3.5	150 HRS.	150 HRS.
ENGINE OIL AC ONLY		1.9	2	100 HRS.	100 HRS.
TRANS/HYDRAULIC OIL	DEXRON III ATF	7.1	7.5	800 HRS.	800 HRS.
AIR CLEANER	CLEAN EVERY 50 HRS.			200 HRS.	
FUEL	SEE MANUAL	24.6	6.5 GAL	400 HRS.	
FUEL PUMP	---	---	---	400 HRS.	
COOLANT 50/50 ETHYLENE GLYCOL WATER	---	3.5	3.7	1200 HRS.	---
TRANS AXLE STRAINER	---	---		CLEAN 800 HRS.	
DIFFERENTIAL OIL	MOBILE 424	0.25	0.26	800 HRS.	---

FOR HEAVY DUTY OPERATION, MAINTENANCE SHOULD BE PERFORMED TWICE AS FREQUENTLY.

Figure 25

Operating in Adverse Conditions

Important: If the machine is subjected to any of the conditions listed below, maintenance should be performed twice as frequently:

- Desert operation
- Cold climate operation below 0° C (32° F)
- Trailer towing
- Frequent operation on dusty roads
- Construction work
- After extended operation in mud, sand, water, or similar dirty conditions, have your brakes inspected and cleaned as soon as possible. This will prevent any abrasive material from causing excessive wear.

Premaintenance Procedures

Many of the subjects covered in this maintenance section require raising and lowering the bed. The following precautions must be taken or serious injury or death could result.

⚠ WARNING

Before servicing or making adjustments to the machine, stop engine, set parking brake, and remove key from the ignition switch. Remove any load material from the bed or other attachment before working under a raised bed. Never work under a raised bed without positioning the safety support on a fully extended cylinder rod.

Using the Bed Support

Important: Always install or remove the bed support from the outside of the bed.

1. Raise the bed until the lift cylinders are fully extended.
2. Remove the bed support from the storage brackets on back of the ROPS panel (Figure 26).

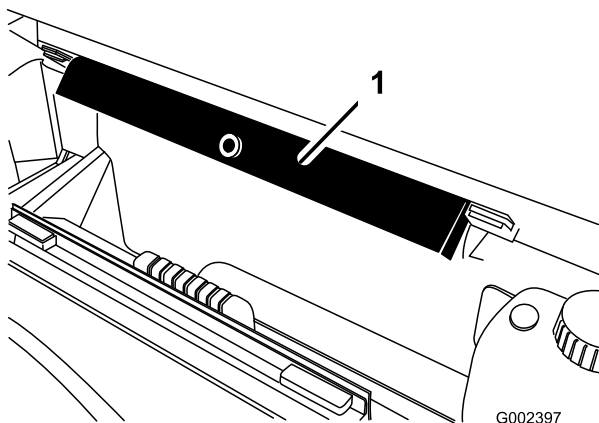

Figure 26

1. Bed support

3. Push the bed support onto the cylinder rod, making sure that the support end tabs rest on the end of cylinder barrel, and on the cylinder rod end (Figure 27).

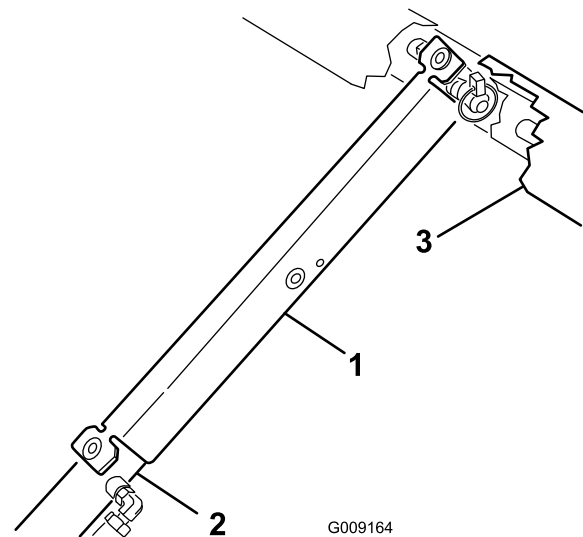

Figure 27

1. Bed support
2. Cylinder barrel
3. Bed

4. Remove the bed support from the cylinder and insert it into the brackets on the back of the ROPS panel.

⚠ CAUTION

Do not try to lower bed with bed safety support on cylinder.

Removing the Full Bed

1. Start the engine. Engage the hydraulic lift lever and lower the bed until the cylinders are loose in the slots.
2. Release the lift lever and turn off the engine.
3. Remove the lynch pins from the outer ends of the cylinder rod clevis pins (Figure 28).

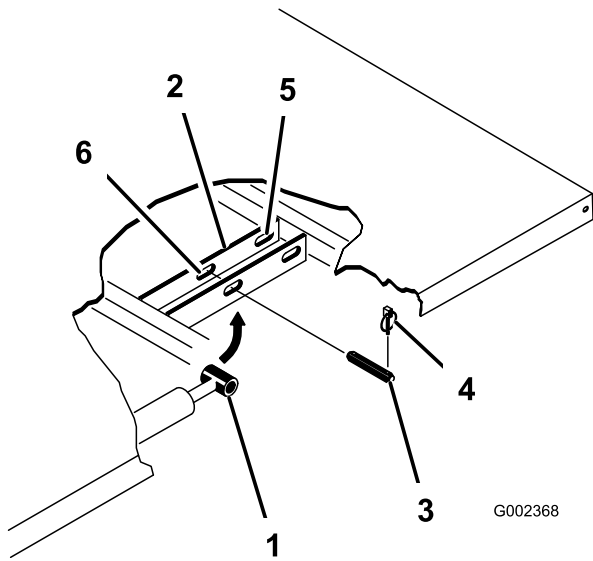

Figure 28

- | | |
|-----------------------|--------------------------|
| 1. Cylinder rod end | 4. Lynch pin |
| 2. Bed mounting plate | 5. Rear slots (Full bed) |
| 3. Clevis pin | 6. Front slots (2/3 bed) |

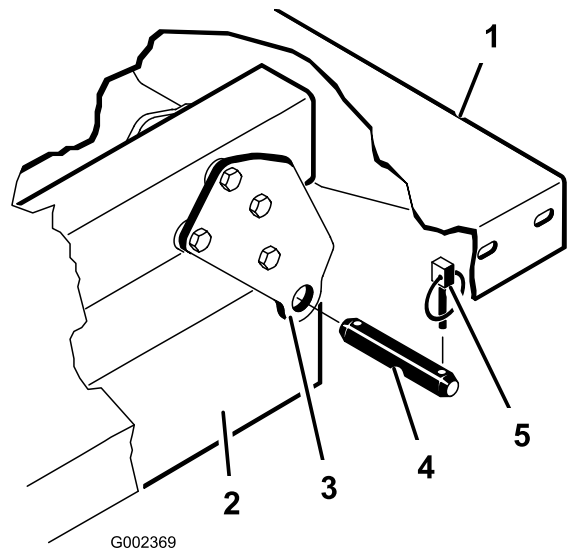

Figure 29

- | | |
|----------------------------|---------------|
| 1. Left rear corner of bed | 4. Clevis pin |
| 2. Machine frame channel | 5. Lynch pin |
| 3. Pivot plate | |

4. Remove the clevis pins securing the cylinder rod ends to the bed mounting plates by pushing the pins towards the inside (Figure 29).
5. Remove the lynch pins and clevis pins securing the pivot brackets to the frame channels (Figure 29).
6. Lift the bed off of the machine.

⚠ CAUTION

The full bed weighs approximately 147.5 kg (325 lb), so do not try to install or remove it by yourself. Use an overhead hoist or get the help of two or three other people.

7. Store the cylinders in the storage clips.
8. Engage the hydraulic lift lock lever on the machine to prevent accidental extension of the lift cylinders.

Note: Ensure that the spacer brackets and wear blocks (Figure 30) are installed with the carriage bolt heads positioned inside the machine.

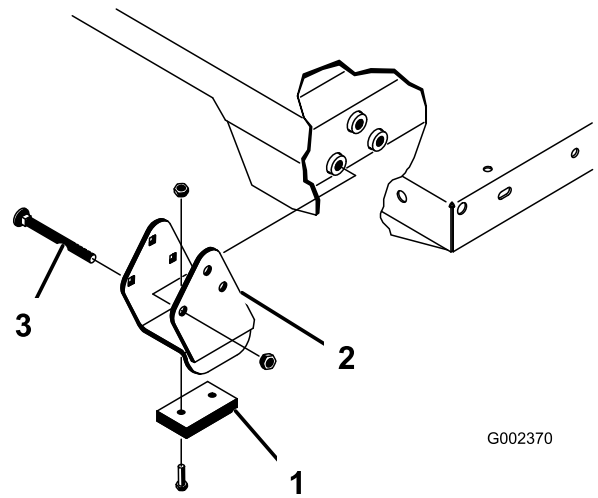

Figure 30

- | | |
|-------------------|------------------|
| 1. Wear block | 3. Carriage bolt |
| 2. Spacer bracket | |

Installing the Full Bed

Note: If the bed sides will be installed on the flat bed, it is easier to install them before installing the bed on the machine.

Note: Ensure that the rear pivot plates are bolted to the bed frame/channel so that lower end angles to the rear (Figure 29).

1. Ensure that the lift cylinders are fully retracted.
2. Carefully set the bed onto the machine frame aligning the rear bed pivot plate holes with the holes in the rear frame channel and install 2 clevis pins and lynch pins (Figure 29).
3. With the bed lowered, secure each cylinder rod end, to the appropriate slots in the bed mounting plates with a clevis pin and lynch pin.

4. Insert the clevis pin from outside of the bed with the lynch pin toward the outside (Figure 29).

Note: The rear slots are for a full bed installation and front slots are for a 2/3 bed installation.

Note: The engine may need to be started to extend or retract the cylinders for alignment with the holes.
Keep fingers out!

Note: The unused slot can be plugged with a bolt and nut to prevent assembly errors.

5. Start the engine and engage the hydraulic lift lever to raise the bed. Release the lift lever and turn off the engine. Install the bed safety support to prevent accidental lowering of the bed. Refer to Using the Bed Safety Support.
6. Install the lynch pins to the inside ends of the clevis pins.

Note: If the automatic tail gate release has been installed on the bed, ensure that the front dump link rod has been placed on the inside of the left side clevis pin before the lynch pin is installed.

Raising the Machine

▲ DANGER

A machine on a jack may be unstable and slip off of the jack, injuring anyone beneath it.

- Do not start the machine while the machine is on a jack.
- Always remove the key from the switch before getting off of the machine.
- Block the tires when the machine is on a jack.
- Do not start the engine while the machine is on a jack, because the engine vibration or wheel movement could cause the machine to slip off of the jack.
- Do not work under the machine without jack stands supporting it. The machine could slip off a jack, injuring any one beneath it.
- When jacking up the front of the machine, always place a 2 x 4 block (or similar material) between the jack and the machine frame.
- The jacking point at the front of the machine is under the front center frame support (Figure 31) and at the rear it is under the axle (Figure 32).

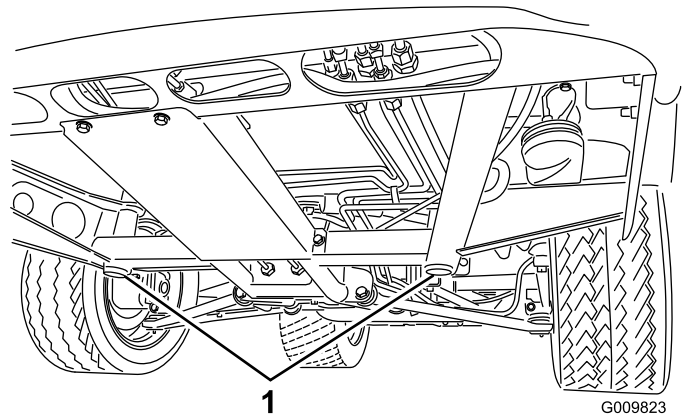

Figure 31

1. Front jacking points

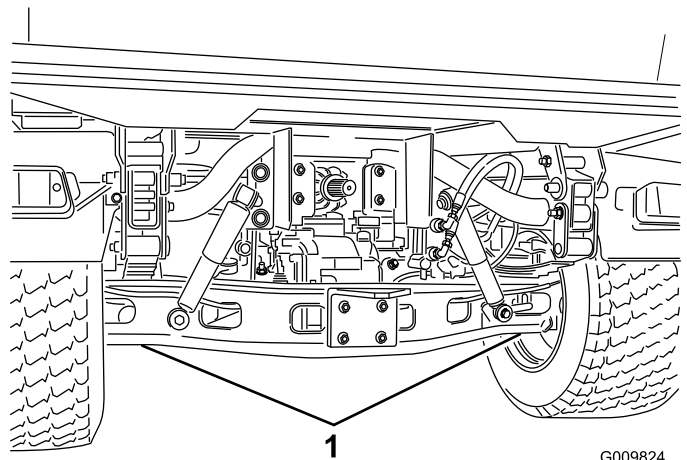

Figure 32

1. Rear jacking points

Removing the Hood

1. While grasping the hood in the headlight openings, lift up on the hood to release the lower mounting tabs from the frame slots (Figure 33).

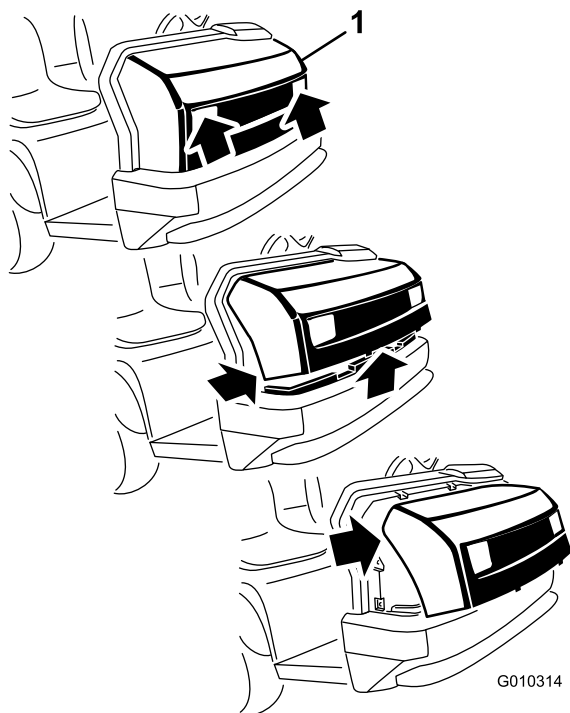

Figure 33

1. Hood

2. Pivot the bottom of the hood upward until the top mounting tabs can be pulled from the frame slots (Figure 33).
3. Pivot the top of hood forward and unplug the wire connectors from the head lights (Figure 33).
4. Remove the hood.

Installing the Hood

1. Connect the lights.
2. Insert the top mounting tabs into the frame slots.
3. Insert the lower mounting tabs into the frame slots.
4. Ensure that the hood is fully engaged in the top, sides and bottom grooves.

Lubrication

Greasing Bearings and Bushings

Service Interval: Every 100 hours (Lubricate more frequently in heavy duty applications)

The machine has grease fittings that must be lubricated regularly with No. 2 General Purpose Lithium Base Grease.

The grease fitting locations and quantities are as follows:

- Ball joints (4), tie rods (2), pivot mounts (2) and steering cylinder (2) (Figure 34)
- Spring tower (2) (Figure 35)
- Clutch (1), accelerator (1), brake (1) (Figure 36)
- U-joint (18) (Figure 37)

Important: When greasing the drive shaft universal shaft bearing crosses, pump grease until it comes out of all 4 cups at each cross.

1. Wipe each grease fitting clean so foreign matter cannot be forced into the bearing or bushing.
2. Pump grease into each bearing or bushing.
3. Wipe off excess grease.

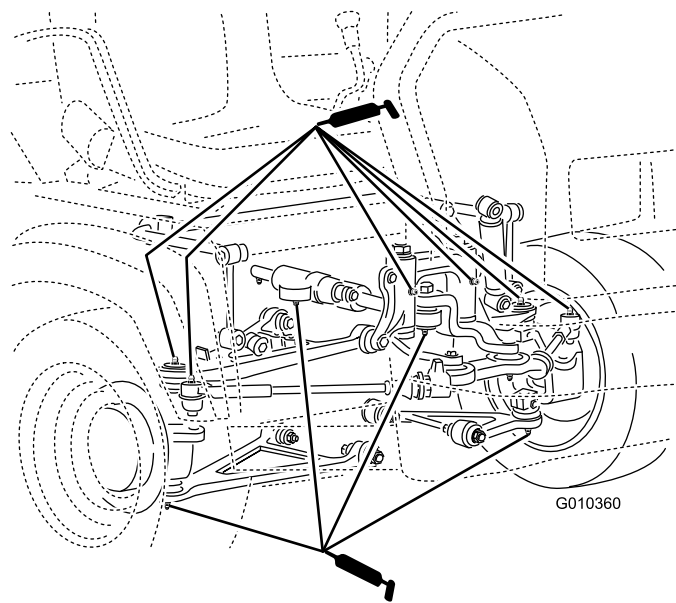

Figure 34

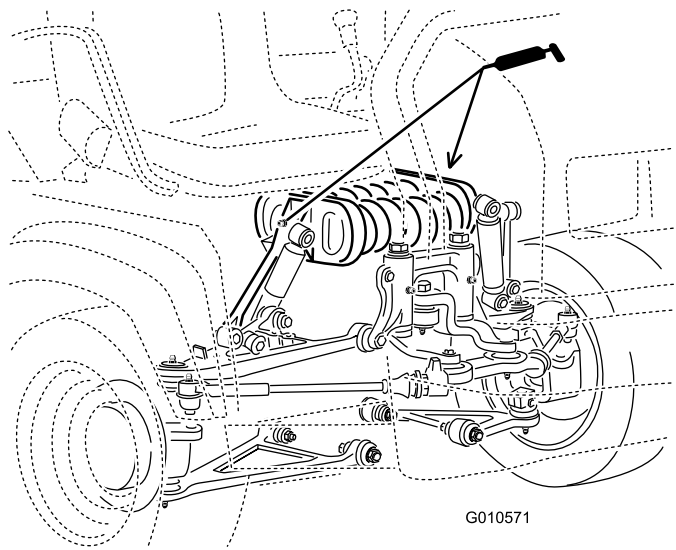

Figure 35

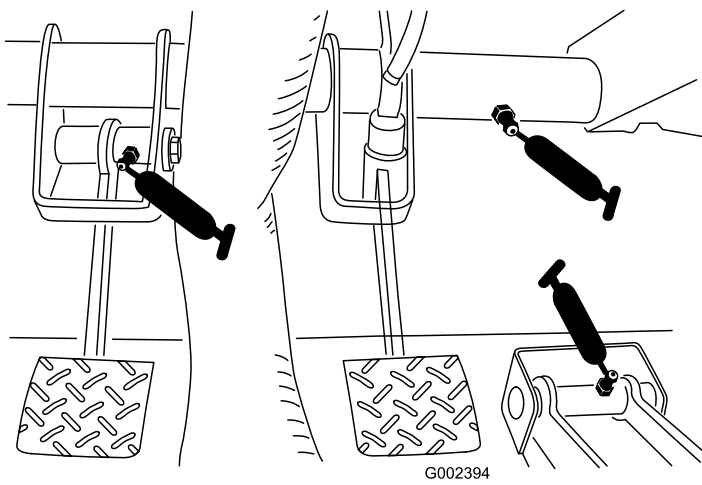

Figure 36

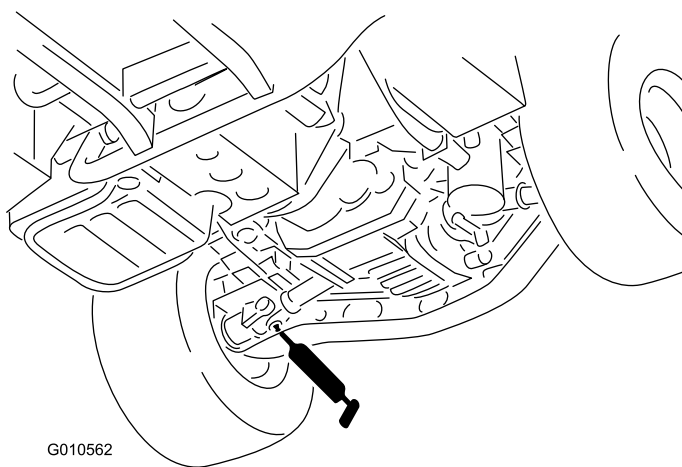

Figure 37

Engine Maintenance

Inspecting the Carbon Canister Air Filter

Service Interval: After the first 50 hours

Every 200 hours

1. Locate the air filter on the bottom of the carbon canister (Figure 38).

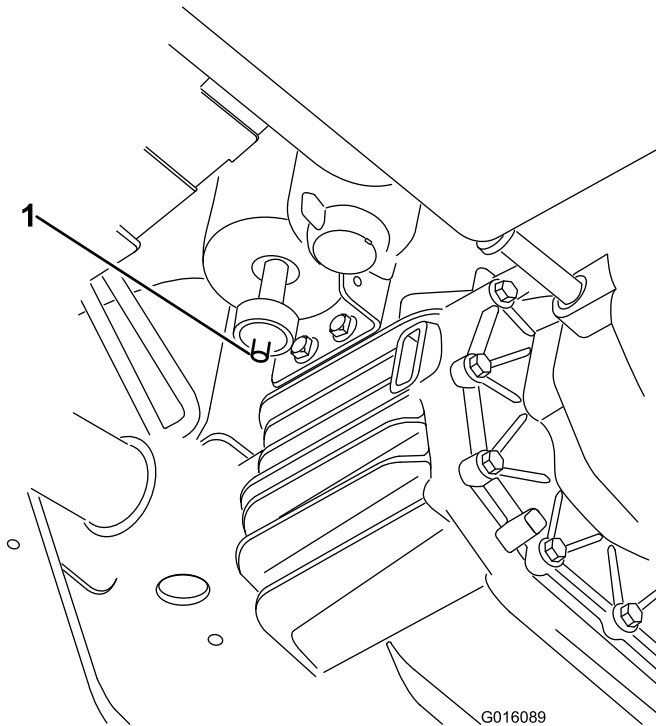

Figure 38

1. Filter opening

2. Ensure that the opening on the bottom of the filter is clear and open.

Servicing the Air Cleaner

Service Interval: Every 50 hours—Clean and oil the air cleaner foam pre-cleaner. (Every 25 hours if operating conditions are extremely dusty or sandy)

Every 50 hours—Inspect the air cleaner paper element.

Every 200 hours

1. Remove the knob, O-ring, and cover (Figure 39).

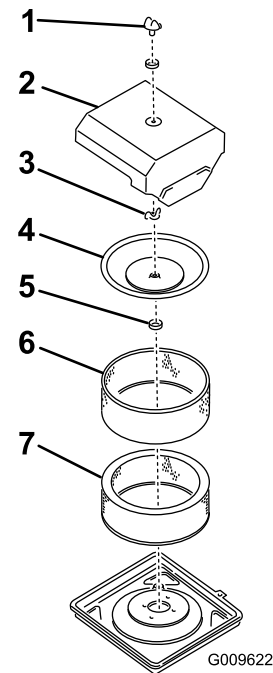

Figure 39

- | | |
|----------------------|---------------------|
| 1. Knob and O-ring | 5. Breather seal |
| 2. Air cleaner cover | 6. Foam pre-cleaner |
| 3. Wing nut | 7. Paper element |
| 4. Inner cover | |

2. Remove the foam pre-cleaner by sliding it off of the paper element, and clean it as follows:
 - A. Wash the foam pre-cleaner in detergent and warm water.
 - B. Wrap the foam pre-cleaner in cloth and press dry. Do not wring the pre-cleaner. Allow it to air dry.
 - C. Saturate the foam pre-cleaner in clean engine oil. Press it to remove any excess oil.

3. Install the foam pre-cleaner onto the paper element.

Do not wash the paper element or clean it with compressed air, as damage will occur.

Note: With the air cleaner disassembled, check the air cleaner components for damage. Replace and damaged parts.

4. Install the element with the pre-cleaner, breather seal, inner cover, wing nut, air cleaner cover, O-ring, and knob.
5. Tighten the knob 1/2 to 1 turn after knob contacts the cover. **Do not overtighten.**

Changing the Engine Oil And Filter

Service Interval: After the first 50 hours

Every 100 hours

1. Raise the bed (if so equipped) and place the safety support on the extended lift cylinder to hold up the bed.
2. Remove the drain plug and let oil flow into a drain pan (Figure 40). When the oil stops, install the drain plug.

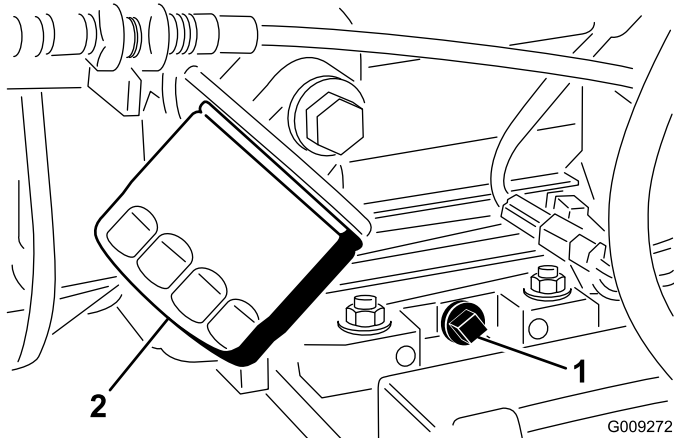

Figure 40

1. Engine oil drain plug
2. Engine oil filter

3. Remove the oil filter (Figure 40).
4. Apply a light coat of clean oil to the new filter seal before screwing it on.
5. Screw the filter on until the gasket contacts the mounting plate, then tighten the filter 1/2 to 2/3 of a turn. **Do not overtighten.**
6. Add oil to the crankcase; refer to Checking the Engine Oil Level.

Replacing the Spark Plugs

Service Interval: Every 800 hours

The spark plugs usually last a long time; however, the plugs should be removed and checked whenever the engine malfunctions. Replace the spark plugs to ensure proper engine performance and reduce exhaust emission level.

The correct spark plug to use is a Champion RC 12YC or equivalent.

The recommended air gap is 1 mm (0.040 inch).

1. Clean the area around the spark plugs so foreign matter cannot fall into the cylinder when you remove the spark plug.
2. Pull wires off of the spark plugs and remove the plugs from the cylinder head.
3. Check the condition of the side electrode, center electrode, and center electrode insulator to ensure that there is no damage.

Important: A cracked, fouled, dirty, or otherwise malfunctioning spark plug must be replaced. Do not sand blast, scrape, or clean electrodes by using a wire brush because grit may eventually release from the plug and fall into the cylinder. The result is usually a damaged engine.

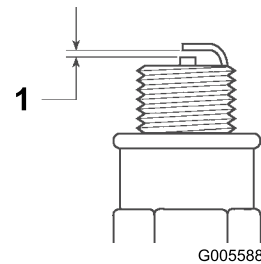

Figure 41

1. Air gap at 1 mm (0.040 inch)

4. Set the air gap one each plug between the center and side electrodes at 1 mm (0.040 inch).
5. Install the correctly gapped spark plugs and tighten them to 24.5 to 29 N-m (18 to 22 ft-lb). If you cannot use a torque wrench, tighten the plugs firmly.
6. Install the spark plug wires.

Fuel System Maintenance

Replacing the Fuel Filter

Service Interval: Every 400 hours

1. Raise the bed (if so equipped) and place the safety support on the extended lift cylinder to hold up the bed.
2. Place a clean container under the fuel filter (Figure 42).

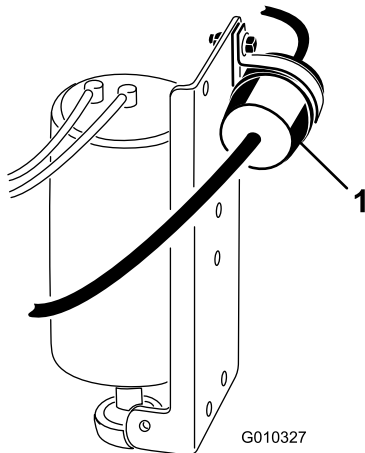

Figure 42

1. Fuel filter

3. Loosen the R-clamp securing the filter to the frame.
4. Remove the clamps securing the fuel filter to the fuel lines.
5. Install a new fuel filter to fuel lines with the clamps previously removed. **The filter must be mounted so the arrow points toward the carburetor.**
6. Tighten the R-clamp securing the filter to the frame.
7. Wipe up and spilled fuel.

Inspecting the Fuel Lines and Connections

Service Interval: Every 400 hours/Yearly (whichever comes first)

Every 1,000 hours/Every 2 years (whichever comes first)

Inspect the fuel lines and connections for deterioration, damage, or loose connections.

Electrical System Maintenance

Servicing the Fuses

The fuses for the machine's electrical system are located under the center of the dash panel (Figure 43 & Figure 44).

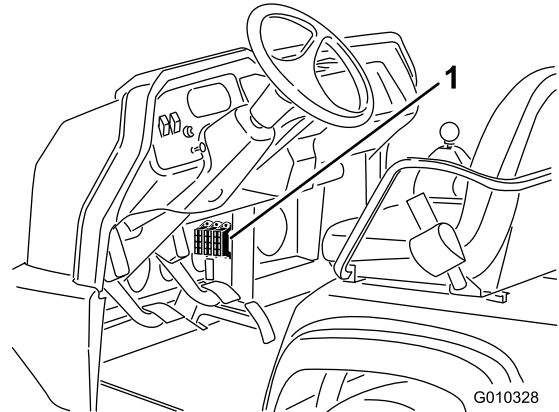

Figure 43

1. Fuses

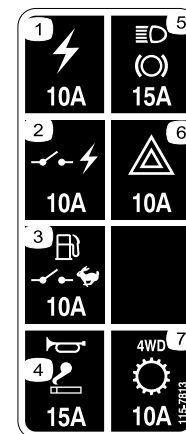

Figure 44

Jump Starting the Machine

⚠ WARNING

Jump starting can be dangerous. To avoid personal injury or damage to electrical components in machine, observe the following warnings:

- Never jump start with a voltage source greater than 15 volts D.C. This will damage the electrical system.
- Never attempt to jump start a discharged battery that is frozen. It could rupture or explode during jump starting.
- Observe all battery warnings while jump starting your machine.
- Be sure your machine is not touching the jump start machine.
- Connecting cables to the wrong post could result in personal injury and/or damage to the electrical system.

1. Squeeze the battery cover to release the tabs from battery base. Remove the battery cover from the battery base (Figure 45).

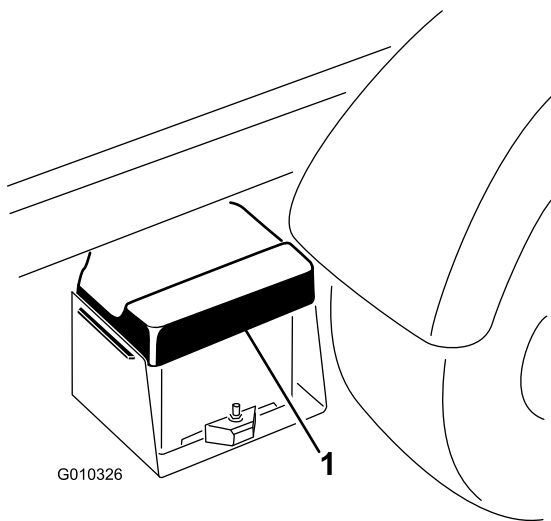

Figure 45

1. Battery cover

2. Connect the positive cable to the positive (+) terminal of the discharged battery (Figure 46). The positive post may be identified by a + sign on top of the battery cover.
3. Connect the other end of the positive cable to the positive (+) terminal of the booster battery.
4. Connect the black negative cable to the negative (-) terminal of the booster battery.
5. Connect the other end of the negative cable to the engine block or frame.

Note: Do not connect the other end of the jumper cable to the negative post of the discharged battery. Connect it to the engine or frame. Do not connect the jumper cable to the fuel system.

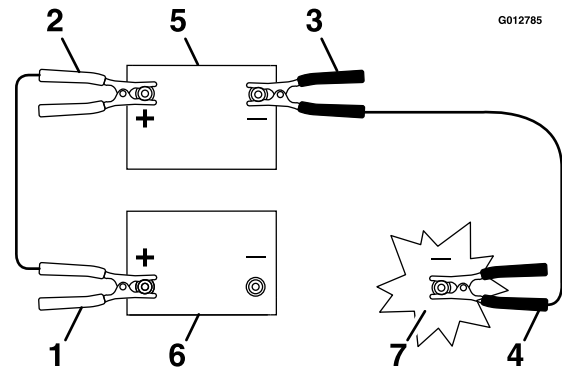

Figure 46

1. Positive (+) cable on the discharged battery
2. Positive (+) cable on the booster battery
3. Negative (-) cable on the booster battery
4. Negative (-) cable on the engine block
5. Booster battery
6. Discharged battery
7. Engine block or frame

6. Start the engine in the machine providing the jump start. Let it run a few minutes, then start your engine.
7. Remove the negative jumper cable first from the engine block or frame, then the booster battery in the other machine.
8. Install the battery cover to the battery base.

Servicing the Battery

Service Interval: Every 50 hours—Check the battery cable connections.

WARNING

CALIFORNIA Proposition 65 Warning

**Battery posts, terminals, and related accessories contain lead and lead compounds, chemicals known to the State of California to cause cancer and reproductive harm.
Wash hands after handling.**

- Keep the top of the battery clean by washing it periodically with a brush dipped in ammonia or bicarbonate of soda solution. Flush the top surface with water after cleaning. Do not remove the fill cap while cleaning.
- Ensure that the battery cables are kept tight on the terminals to provide good electrical contact.

- If corrosion occurs at terminals, remove the battery cover, disconnect the cables (negative (–) cable first), and scrape the clamps and terminals separately. Reconnect the cables (positive (+) cable first) and coat the terminals with petroleum jelly.
- If you store the machine in a location where temperatures are extremely high, the battery will run down more rapidly than if the machine is stored in a location where temperatures are cool.

Drive System Maintenance

Adjusting the Shift Cables

Service Interval: After the first 10 hours

Every 200 hours

1. Move shift lever to the Neutral position.
2. Remove the clevis pins securing the shift cables to the transaxle shift arms (Figure 47).

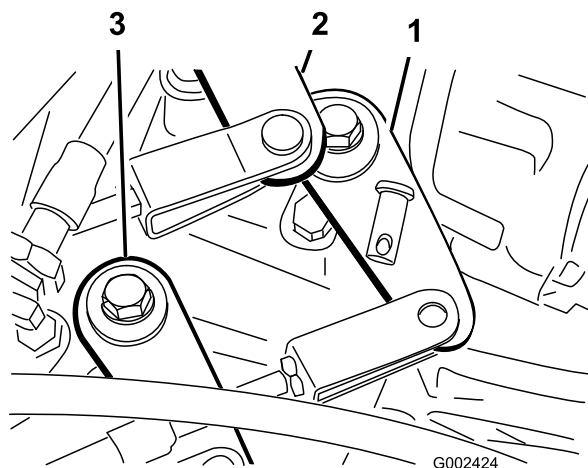

Figure 47

- | | |
|-------------------------|-------------------------|
| 1. Shift arm (1st-Rev.) | 3. Shift arm (High-Low) |
| 2. Shift arm (2nd-3rd) | |

3. Loosen the clevis jam nuts and adjust each clevis so cable free play is equal forward and backward relative to the hole in the transaxle shift arm (with the transaxle lever free play taken up in the same direction).
4. Install the clevis pins and tighten the jam nuts when finished.

Adjusting the High-Low Cable

Service Interval: Every 200 hours

1. Remove the clevis pin securing the High-Low cable to the transaxle (Figure 47).
2. Loosen the clevis jam nut and adjust the clevis so that the clevis hole aligns with the hole in the transaxle bracket.
3. Install the clevis pin and tighten the jam nut when finished.

Adjusting Differential Lock Cable

Service Interval: Every 200 hours

1. Move the differential lock lever to the Off position.

- Loosen the jam nuts securing the differential lock cable to the bracket on the transaxle (Figure 48).

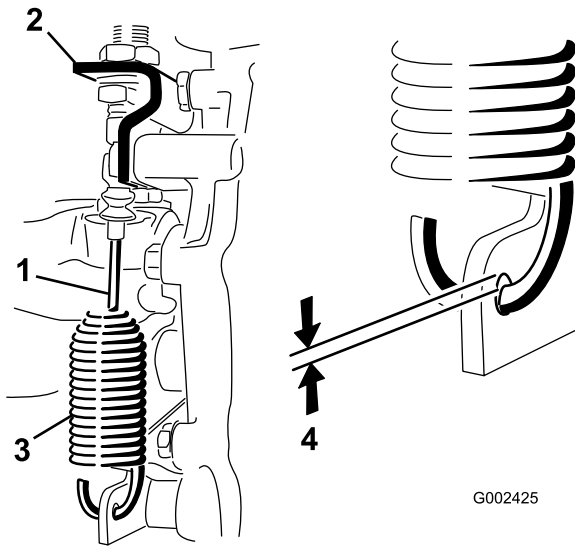

Figure 48

- | | |
|----------------------------|---|
| 1. Differential lock cable | 3. Spring |
| 2. Transaxle bracket | 4. 0.25 to 1.5 mm (0.01 to 0.06 inch) gap |

- Adjust the jam nuts to obtain a 0.25 to 1.5 mm (0.01 to 0.06 inch) gap between the spring hook and the O.D. of the hole in the transaxle lever.
- Tighten the jam nuts when finished.

Inspecting the Tires

Service Interval: Every 100 hours

Operating accidents, such as hitting curbs, can damage a tire or rim and also disrupt wheel alignment, so inspect tire condition after an accident.

Check the tire pressure frequently to ensure proper inflation. If the tires are not inflated to the correct pressure, the tires will wear prematurely.

Figure 49 is an example of tire wear caused by under inflation.

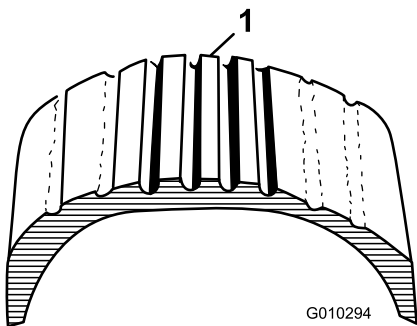

Figure 49

- Under inflated tire

Figure 50 is an example of tire wear caused by over inflation.

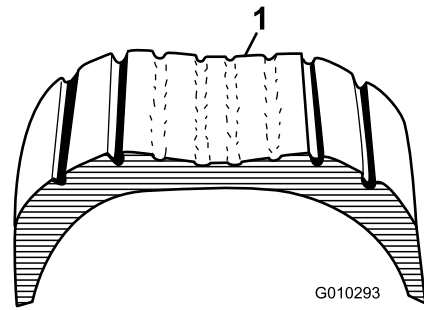

Figure 50

- Over inflated tire

Checking the Front-wheel Alignment

Service Interval: Every 400 hours/Yearly (whichever comes first)

- Make sure the tires are facing straight ahead.
- Measure the center-to-center distance (at axle height) at the front and rear of the steering tires (Figure 51). The measurement must be within 0 ± 3 mm (0 ± 0.12 inch) at the front of the tire then at the rear of the tire. Rotate the tire 90 degrees and recheck the measurement.

Important: Check the measurements at consistent locations on the tire. The machine should be on a flat surface with the tires facing straight ahead.

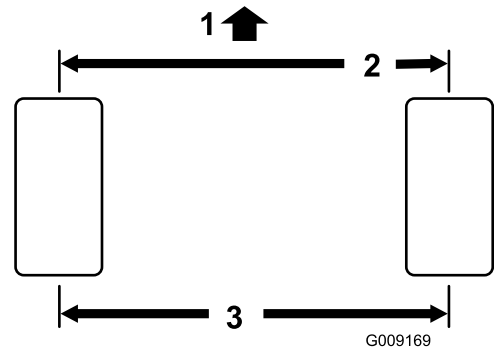

Figure 51

- | | |
|--|------------------------------|
| 1. Front of machine | 3. Center to center distance |
| 2. 0 ± 3 mm (0 ± 0.12 inch) front to rear of tire | |

- Adjust the center-to-center distance as follows:
 - Loosen the jam nut at the center of the tie rod (Figure 52).

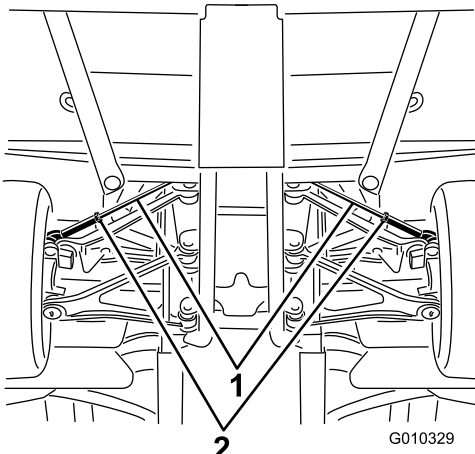

Figure 52

1. Tie rods 2. Jam nuts
-

- B. Rotate the tie rod to move the front of the tire inward or outward to achieve the center to center distances from front to back.
- C. Tighten the tie rod jam nut when the adjustment is correct.
- D. Check to ensure that the tires turn an equal amount to the right and to the left.

Note: If the tires do not turn equally, refer to the *Service Manual* for the adjustment procedure.

Cooling System Maintenance

Removing Debris from the Engine Cooling System

Service Interval: Every 100 hours (Clean more frequently in dirty conditions.)

To ensure proper cooling, clean the blower housing and other cooling shrouds and clean the cooling fins and external surfaces.

Note: Operating the engine with dirty or plugged cooling fins or with the cooling shrouds removed, will cause engine damage due to overheating.

Brake Maintenance

Adjusting the Parking Brake

Service Interval: After the first 10 hours

Every 200 hours

1. Remove the rubber grip from the parking brake lever (Figure 53).

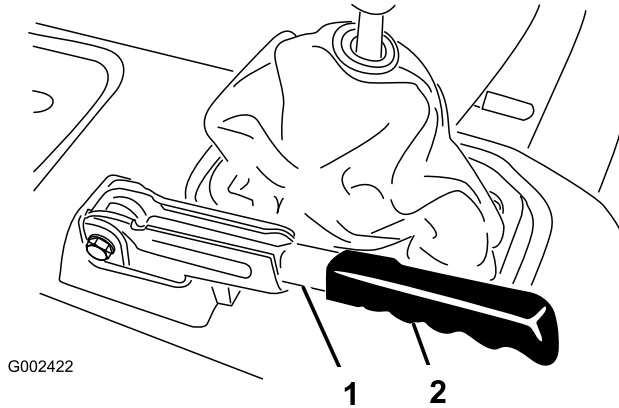

Figure 53

1. Parking brake lever
2. Grip

2. Loosen the set screw securing the knob to the parking brake lever (Figure 54).
3. Rotate the knob until a force of 20 to 22 kg (45 to 50 lb) is required to actuate the lever.

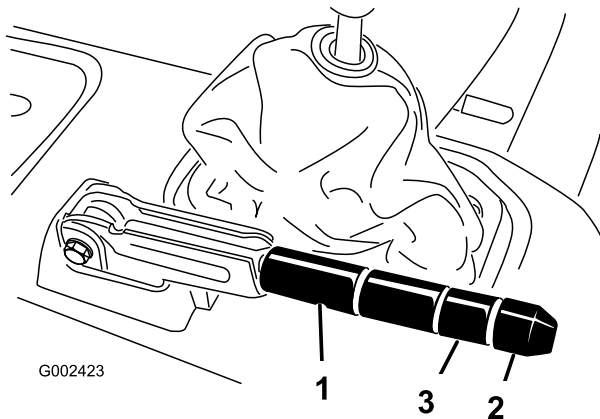

Figure 54

1. Parking brake lever
2. Knob
3. Set screw

4. Tighten the set screw when finished.

Note: If no adjustment is left at the handle, loosen the handle to the middle of the adjustment and adjust the cable at the rear, then repeat step 3.

5. Install the rubber grip onto the parking brake lever.

Adjusting the Brake Pedal

Service Interval: Every 200 hours

Note: Remove the front hood to ease the adjustment procedure.

1. Remove the cotter pin and clevis pin securing the master cylinder yoke to the brake pedal pivot (Figure 55).

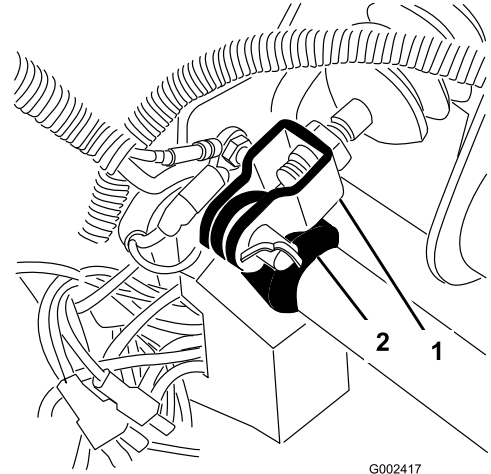

Figure 55

1. Master cylinder yoke
2. Brake pedal pivot

2. Lift up on the brake pedal (Figure 56) until it contacts the frame.

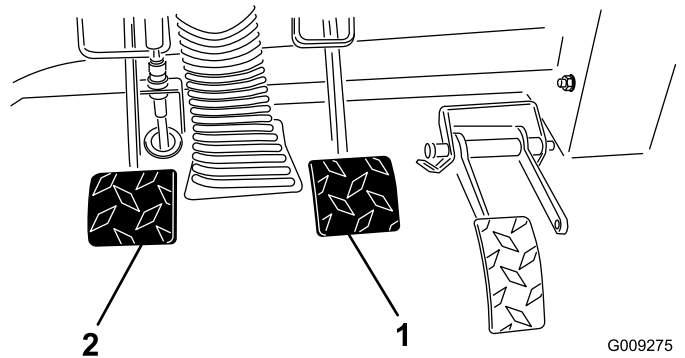

Figure 56

1. Brake pedal
2. Clutch pedal

3. Loosen the jam nuts securing the yoke to the master cylinder shaft (Figure 55).
4. Adjust the yoke until its holes align with the hole in the brake pedal pivot.
5. Secure the yoke to the pedal pivot with the clevis pin and cotter pin.
6. Tighten the jam nuts securing the yoke to the master cylinder shaft.

Note: The brake master cylinder must relieve pressure when properly adjusted.

Belt Maintenance

Checking the Pump Belt Tension

Service Interval: After the first 10 hours

Every 200 hours

Check the pump belt for wear, cracking, or improper tension. Check the tension by pressing belt at mid span between the crankshaft and pump pulleys with 10 kg (22 lb) of force. A new belt should deflect 12 to 15 mm (0.48 to 0.58 inch). A used belt should deflect 14 to 16.5 mm (0.55 to 0.65 inch). If the deflection is incorrect, refer to Belt Maintenance for the tensioning procedure. If correct, continue operation.

Important: Improper belt tension may result in increased steering effort.

Adjusting the Pump Drive Belt

1. Raise the bed (if so equipped) and position the safety support on the extended lift cylinder to hold up the bed.
2. Check the tension by pressing the belt at mid span between the crankshaft and pump pulleys with 10 kg (22 lb) of force. A new belt should deflect 12 to 15 mm (0.48 to 0.58 inch). A used belt should deflect 14 to 16.5 mm (0.55 to 0.65 inch). If the deflection is incorrect, proceed to next step. If correct, continue operation.
3. To adjust belt tension, complete the following:
 - A. Loosen the nuts securing the hydraulic pump to the engine frame (Figure 57).

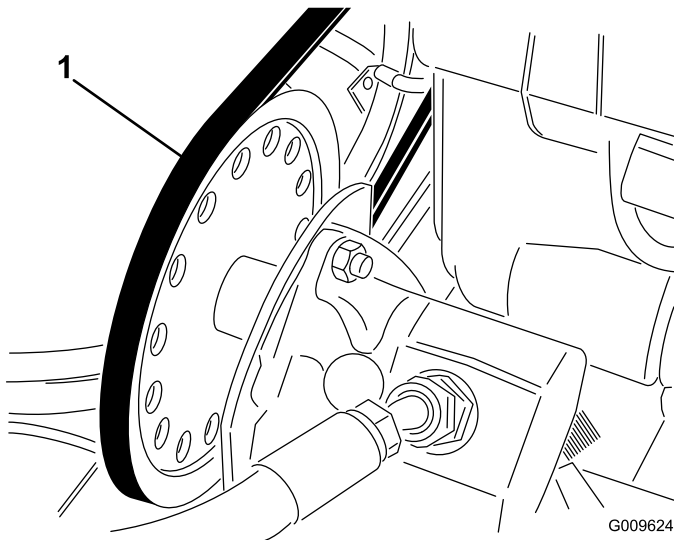

Figure 57

1. Pump drive belt

- B. Rotate the pump until the desired belt tension is attained. Tighten the nuts.

Controls System Maintenance

Adjusting the Clutch Pedal

Service Interval: Every 200 hours

Note: You can adjust the clutch pedal cable at the bell housing or at the clutch pedal pivot. The front hood can be removed to ease the access to pedal pivot.

1. Loosen the jam nuts securing the clutch cable to the bracket on the bell housing (Figure 58).

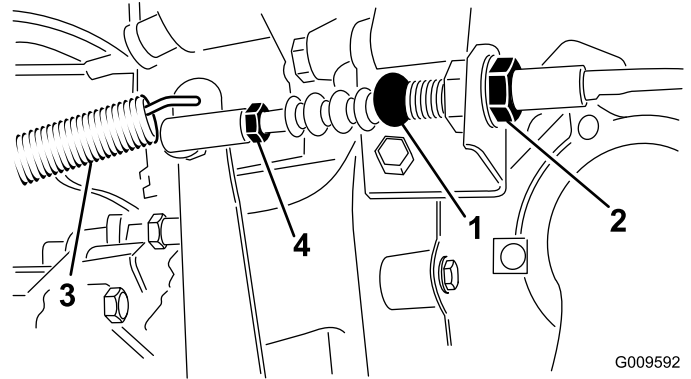

Figure 58

- | | |
|-----------------|------------------|
| 1. Clutch cable | 3. Return spring |
| 2. Jam nuts | 4. Ball joint |

Note: You may remove and rotate the ball joint, if additional adjustment is required.

2. Disconnect the return spring from the clutch lever.
3. Adjust the jam nuts or ball joint until the back, rear edge of the clutch pedal is 9.5 ± 0.3 cm (3.75 ± 0.12 inch) from the top of the floor plate diamond pattern, when an 1.8 kg (4 lb) force is applied to the pedal (Figure 59).

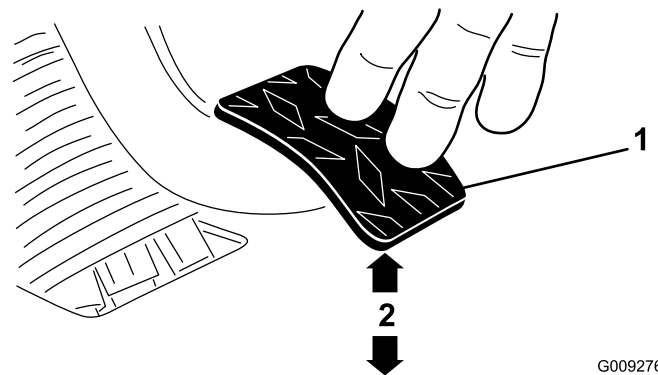

Figure 59

- | | |
|-----------------|---|
| 1. Clutch pedal | 2. 9.5 ± 0.3 cm (3.75 ± 0.12 inch) |
|-----------------|---|

Note: Force is applied so the clutch release bearing lightly contacts the pressure plate fingers.

4. Tighten the jam nuts after the adjustment has been attained.
5. Recheck the 9.5 ± 0.3 cm (3.75 ± 0.12 inch) dimension after the jam nuts have been tightened to ensure proper adjustment. Readjust, if necessary.
6. Connect the return spring to the clutch lever.

Important: Ensure that the rod end is positioned squarely on the ball, not twisted, and remains parallel to the clutch pedal after the jam nut is tightened (Figure 60).

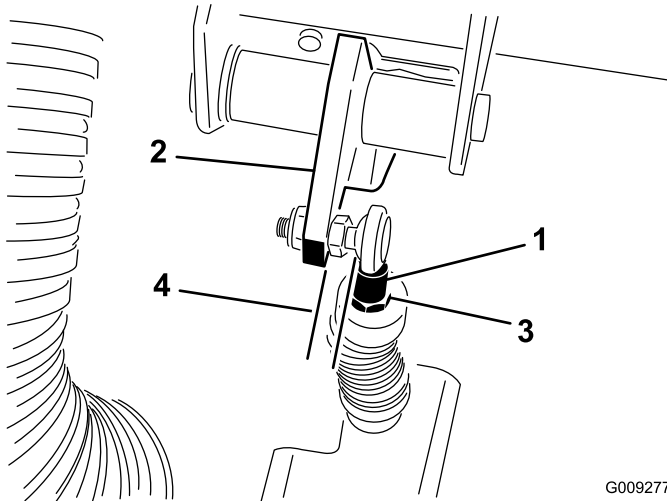

Figure 60

- | | |
|-------------------------|--------------------|
| 1. Clutch cable rod end | 3. Rod end jam nut |
| 2. Clutch pedal | 4. Parallel |

Note: The clutch free play should never be less than 19 mm (0.75 inch).

Adjusting the Accelerator

Service Interval: Every 200 hours

1. Position the machine on a level surface, stop the engine, and engage the parking brake.
2. With the return spring installed, hold the engine governor arm toward the operator's side of the machine and adjust the low idle stop to obtain a 0.25 to 1.25 mm (0.01 to 0.05 inch) gap between the O.D. of the hole in the throttle lever and the inside of the governor spring hook (Figure 61).

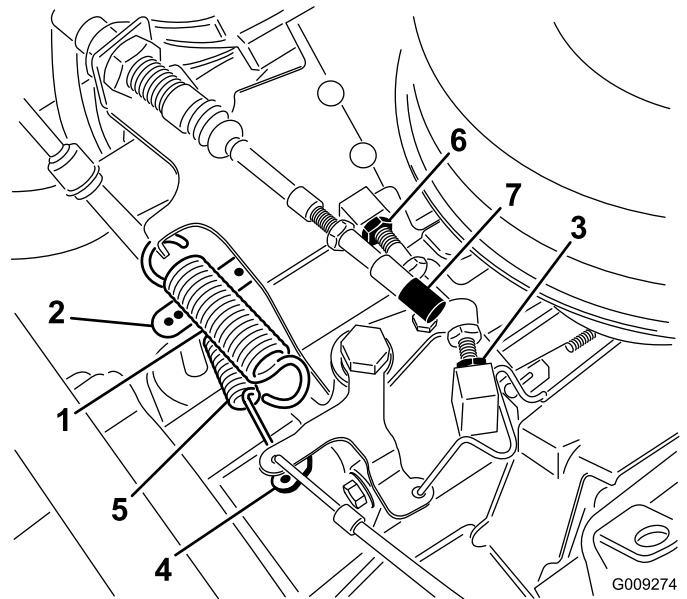

Figure 61

- | | |
|------------------------|--------------------|
| 1. Return spring | 5. Governor spring |
| 2. Engine governor arm | 6. High idle stop |
| 3. Low idle stop | 7. Ball joint |
| 4. Throttle lever | |

▲ WARNING

The engine must be running so the final adjustment of the accelerator can be performed. To guard against possible personal injury, engage the parking brake and keep hands, feet, face, and other parts of your body away from any moving parts.

3. Start the engine and allow it to warm up to normal operating temperature. Verify the low idle setting of 1200 ± 100 rpm.
4. Adjust the high idle stop to obtain 3600 ± 50 rpm when the throttle lever contacts the stop.
5. Stop the engine.
6. Adjust the ball joint on the accelerator cable and/or cable jam nuts while the throttle lever is against high idle stop to allow 2.54 to 6.35 mm (0.100 to 0.250 inch) of clearance between the accelerator pedal arm and the top of the diamond tread floor plate, when a 11.3 kg (25 lb) force is applied to the center of the pedal (Figure 62). Tighten the locknut.

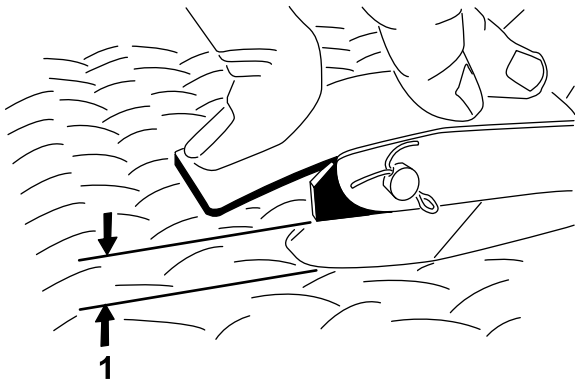

G002412

Figure 62

1. 2.54 to 6.35 mm (0.100 to 0.250 inch) clearance

Note: The engine must not be running and the return spring must be attached.

Adjusting the Choke

1. Raise the bed (if so equipped) and position the safety support on the extended lift cylinder to hold up the bed. Stop the engine and the engage parking brake.
2. Loosen the cable clamp screw securing the cable to the engine.
3. Push the choke knob to the Off position.
4. Push the choke cable firmly toward the operator's side of the machine and tighten the cable clamp screw.

Converting the Speedometer

You can convert the speedometer from mph to km/h or km/h to mph.

1. Position the machine on a level surface, stop the engine, engage the parking brake, and remove the key from the ignition switch.
2. Remove the hood; refer to [Removing the Hood \(page 32\)](#).
3. Locate the 2 loose wires next to the speedometer.
4. Remove the connector plug from the harness wire and connect the wires together.

Note: The speedometer will switch to km/h or mph.

5. Install the hood.

Hydraulic System Maintenance

Changing the Hydraulic Fluid and Cleaning the Strainer

Service Interval: Every 800 hours

1. Position the machine on a level surface, stop the engine, engage the parking brake, and remove the key from the ignition switch.
2. Remove the drain plug from the side of the reservoir and let the hydraulic fluid flow into a drain pan ([Figure 63](#)).

Note: Clean the hydraulic strainer. Refer to [Cleaning Hydraulic Strainer](#).

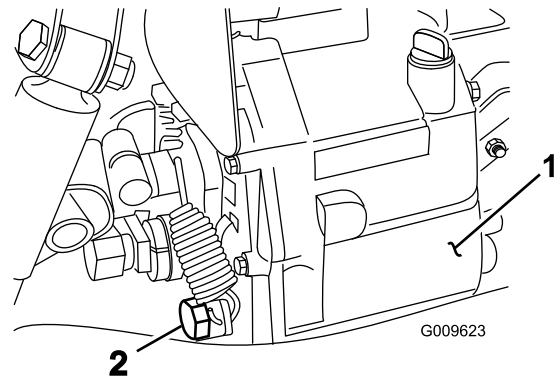

G009623

Figure 63

1. Hydraulic reservoir
2. Drain plug

3. Note the orientation of the hydraulic hose and 90 degree fitting connected to the strainer on the side of the reservoir ([Figure 64](#)). Remove the hydraulic hose and 90 degree fitting.
4. Remove the strainer and clean it by back flushing it with a clean de-greaser. Allow it to air dry before installing.

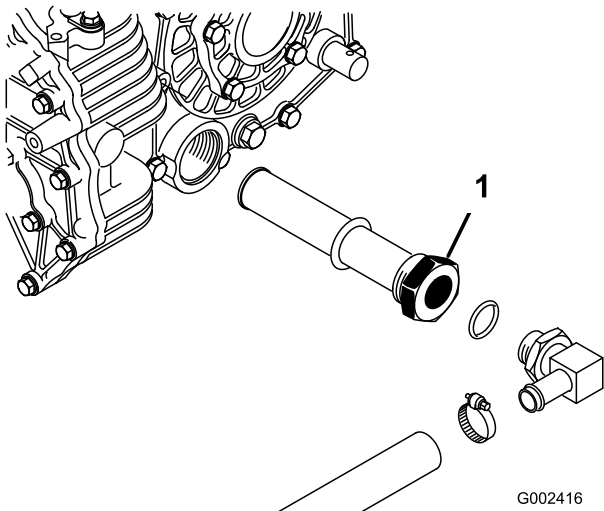

Figure 64

1. Hydraulic strainer

5. Install the strainer.
6. Install the hydraulic hose and 90 degree fitting to the strainer in the same orientation.
7. Install and tighten the drain plug.
8. Fill the reservoir with approximately 7 L (7.5 qt) of Dexron III ATF. Refer to Checking the Hydraulic Fluid Level.
9. Start the engine and operate the machine to fill the hydraulic system. Check the hydraulic oil level and replenish it, if required.

Important: Use only the hydraulic fluids specified. Other fluids could cause system damage.

Replacing the Hydraulic Filter

Service Interval: After the first 10 hours

Every 800 hours

Important: Use of any other filter may void the warranty on some components.

1. Position the machine on a level surface, stop the engine, engage the parking brake, and remove the key from ignition switch.
2. Clean the area around filter mounting area. Place a drain pan under the filter and remove the filter (Figure 65).

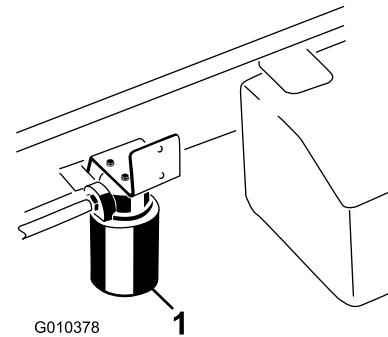

Figure 65

1. Hydraulic filter

3. Lubricate the gasket on the new filter.
4. Ensure that the filter mounting area is clean. Screw the filter on until the gasket contacts the mounting plate. Then tighten the filter one-half turn.
5. Start the engine and let it run for about two minutes to purge air from the system. Stop the engine and check the hydraulic oil level and for leaks.

Raising the Box in an Emergency

The box can be raised in an emergency without starting the engine by cranking starter or by jumping hydraulic system.

Raising the Box using the Starter

Crank the starter while holding the lift lever in the Raise position. Run the starter for 15 seconds then wait 60 seconds before engaging the starter again. If the engine will not crank, you must remove the load and box (attachment) to service the engine or transaxle.

Raising the Box by Jumping the Hydraulic System

CAUTION

Before servicing or making adjustments to the machine, stop the engine, set the parking brake, and remove the key from the switch. Any load material must be removed from the bed or other attachment before working under a raised bed. Never work under a raised bed without positioning the safety support on the fully extended cylinder rod.

Note: 2 hydraulic hoses, each with a male and female quick coupler, that fit the machine couplers are required to perform this operation.

1. Back another machine up to the rear of the disabled machine.

Important: The machines hydraulic system uses Dexron III ATF. To avoid system contamination,

make sure the machine used to jump the hydraulic system uses an equivalent fluid.

2. On both machines, disconnect the 2 quick coupler hoses from the hoses secured to the coupler bracket (Figure 66).

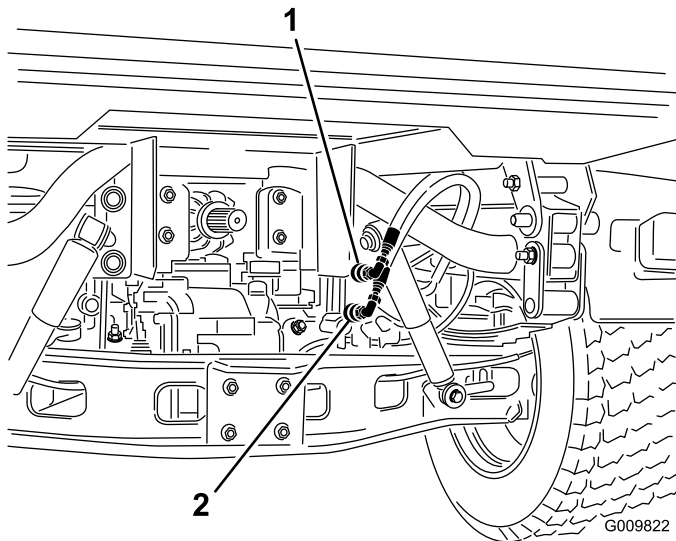

Figure 66

1. Quick coupler hose A
2. Quick coupler hose B

3. On the disabled machine, connect the two jumper hoses to the hoses that were disconnected (Figure 67).
4. Cap the unused fittings.

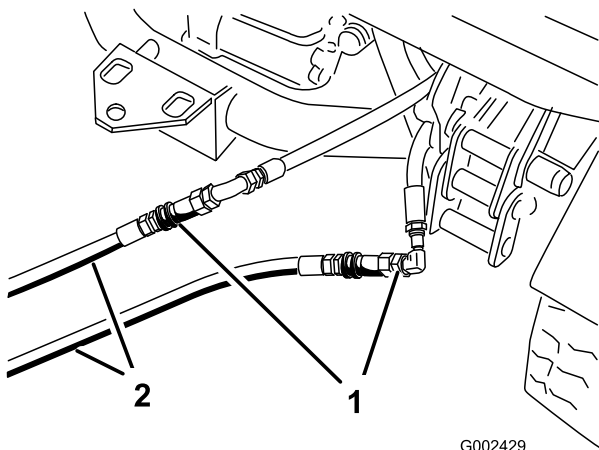

Figure 67

1. Disconnected hoses
2. Jumper hoses

5. On the other machine, connect the two hoses to the coupler still in the coupler bracket (connect the top hose to the top coupler and the bottom hose to the bottom coupler) (Figure 68).
6. Cap the unused fittings.

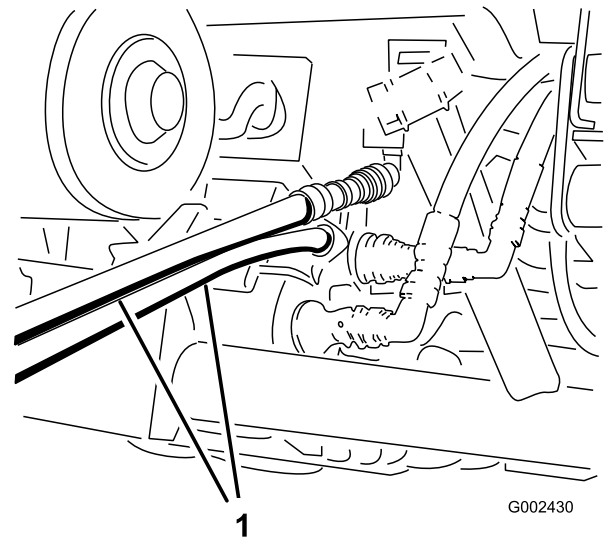

Figure 68

1. Jumper hoses

7. Keep all bystanders away from the machines.
8. Start the second machine and move the lift lever to the raise position which will raise the disabled box.
9. Move the hydraulic lift lever to the neutral position and engage the lift lever lock.
10. Install the bed safety support onto the extended lift cylinder. Refer to Using the Bed Safety Support.

Note: With both the machines turned off, move the lift lever back and forth to remove the system pressure and ease the disconnection of the quick couplers.

11. After completing the operation, remove the jumper hoses and connect the hydraulic hoses to both machines.

Important: Check the hydraulic fluid levels, in both machines, before resuming operation.

Cleaning

Washing the Machine

The machine should be washed as needed. Use water alone or with a mild detergent. A rag may be used when washing the machine, however the hood will lose some of its luster.

Important: Do not use power washing equipment to wash the machine. Power washing equipment may damage the electrical system, loosen important decals, or wash away necessary grease at friction points. Avoid excessive use of water near the control panel, engine, and battery.

Storage

1. Position the machine on a level surface, set the parking brake, stop the engine, and remove the ignition key.
2. Clean dirt and grime from the entire machine, including the outside of the engine cylinder head fins and blower housing.

Important: You can wash the machine with mild detergent and water. Do not use high pressure water to wash the machine. Pressure washing may damage the electrical system or wash away necessary grease at friction points. Avoid excessive use of water, especially near the control panel, lights, engine, and the battery.

3. Inspect the brakes; refer to [Adjusting the Parking Brake \(page 42\)](#).
4. Service the air cleaner; refer to [Servicing the Air Cleaner \(page 35\)](#).
5. Grease the machine; refer to [Greasing Bearings and Bushings \(page 33\)](#).
6. Change the engine oil; refer to [Changing the Engine Oil And Filter \(page 35\)](#).
7. Check the tire pressure; refer to [Checking the Tire Pressure \(page 20\)](#).
8. For storage over 30 days, prepare the fuel system as follows:
 - A. Add a petroleum based stabilizer/conditioner to fuel in the tank.

Follow mixing instructions from stabilizer manufacturer. (1 oz. per gallon). Do not use an alcohol based stabilizer (ethanol or methanol).

Note: A fuel stabilizer/conditioner is most effective when mixed with fresh gasoline and used at all times.

- B. Run the engine to distribute conditioned fuel through the fuel system (5 minutes).
 - C. Stop the engine, allow it to cool, and drain the fuel tank.
 - D. Restart the engine and run it until it stops.
 - E. Choke the engine.
 - F. Start and run the engine until it will not start again.
 - G. Dispose of fuel properly. Recycle as per local codes.
- Important:** Do not store stabilizer/conditioned gasoline over 90 days
9. Remove the spark plugs and check their condition; refer to [Replacing the Spark Plugs \(page 36\)](#).
 10. With the spark plugs removed from the engine, pour two tablespoons of engine oil into the spark plug hole.

11. Use the starter to crank the engine and distribute the oil inside the cylinder.

12. Install the spark plugs and tighten to recommended torque; refer to [Replacing the Spark Plugs \(page 36\)](#).

Note: Do not install the wire on the spark plug(s).

13. Remove the battery from the chassis and charge it fully; refer to [Servicing the Battery \(page 38\)](#).

Note: Do not connect the battery cables to the battery posts during storage.

Important: The battery must be fully charged to prevent it from freezing and being damaged at temperatures below 32°F (0°C). A fully charged battery maintains its charge for about 50 days at temperatures lower than 40°F (4°C). If the temperatures will be above 40°F (4°C), check the water level in the battery and charge it every 30 days.

14. Check and tighten all bolts, nuts, and screws. Repair or replace any part that is damaged.
15. Paint all scratched or bare metal surfaces.
Paint is available from your Authorized Service Distributor.
16. Store the machine in a clean, dry garage or storage area.
17. Remove the ignition key and put it in a safe place out of the reach of children.
18. Cover the machine to protect it and keep it clean.

Troubleshooting

Problem	Possible Cause	Corrective Action
The engine does not start, starts hard, or fails to keep running.	<ol style="list-style-type: none"> 1. The hydraulic lever is locked in forward position 2. The fuel tank is empty. 3. The fuel-shutoff valve is closed. 4. The oil level in the crankcase is low. 5. The throttle is not in the correct position. 6. There is dirt, water, or stale fuel in the fuel system. 7. The air cleaner is dirty. 8. The spark plug is fouled or improperly gapped. 9. The spark-plug wire is not connected. 	<ol style="list-style-type: none"> 1. Move the hydraulic lever out of forward position. 2. Fill the fuel tank. 3. Open the fuel-shutoff valve. 4. Add oil to the crankcase. 5. Be sure that the throttle control is midway between the slow and fast positions. 6. Contact an Authorized Service Dealer. 7. Clean or replace the air-cleaner element. 8. Adjust or replace the spark plug. 9. Check the spark-plug wire connection.
The hydraulics do not work properly.	<ol style="list-style-type: none"> 1. Connecting or disconnecting quick couplers is difficult. 2. There are hydraulic leaks. 	<ol style="list-style-type: none"> 1. Relieve the pressure on the couplers. 2. The fittings are loose or are missing the o-ring.
The power steering is not working properly.	<ol style="list-style-type: none"> 1. The hydraulic-oil level is low. 2. The hydraulic oil is hot. 3. The pump is not operating. 	<ol style="list-style-type: none"> 1. Add hydraulic fluid. 2. Allow the hydraulic oil to cool. 3. Check and ensure the pump is working.
There is a squealing noise.	<ol style="list-style-type: none"> 1. The valve left in the On detent position. 2. The belt is loose. 	<ol style="list-style-type: none"> 1. Disengage the valve left in the On detent position. 2. Ensure the belt has the correct tension.

Notes:



Toro General Commercial Product Warranty

A Two-Year Limited Warranty

Conditions and Products Covered

The Toro Company and its affiliate, Toro Warranty Company, pursuant to an agreement between them, jointly warrant your Toro Commercial product ("Product") to be free from defects in materials or workmanship for two years or 1500 operational hours*, whichever occurs first. This warranty is applicable to all products with the exception of Aerators (refer to separate warranty statements for these products). Where a warrantable condition exists, we will repair the Product at no cost to you including diagnostics, labor, parts, and transportation. This warranty begins on the date the Product is delivered to the original retail purchaser.

* Product equipped with an hour meter.

Instructions for Obtaining Warranty Service

You are responsible for notifying the Commercial Products Distributor or Authorized Commercial Products Dealer from whom you purchased the Product as soon as you believe a warrantable condition exists. If you need help locating a Commercial Products Distributor or Authorized Dealer, or if you have questions regarding your warranty rights or responsibilities, you may contact us at:

Toro Commercial Products Service Department
Toro Warranty Company
8111 Lyndale Avenue South
Bloomington, MN 55420-1196
952-888-8801 or 800-952-2740
E-mail: commercial.warranty@toro.com

Owner Responsibilities

As the Product owner, you are responsible for required maintenance and adjustments stated in your *Operator's Manual*. Failure to perform required maintenance and adjustments can be grounds for disallowing a warranty claim.

Items and Conditions Not Covered

Not all product failures or malfunctions that occur during the warranty period are defects in materials or workmanship. This warranty does not cover the following:

- Product failures which result from the use of non-Toro replacement parts, or from installation and use of add-on, or modified non-Toro branded accessories and products. A separate warranty may be provided by the manufacturer of these items.
- Product failures which result from failure to perform recommended maintenance and/or adjustments. Failure to properly maintain your Toro product per the Recommended Maintenance listed in the *Operator's Manual* can result in claims for warranty being denied.
- Product failures which result from operating the Product in an abusive, negligent, or reckless manner.
- Parts subject to consumption through use unless found to be defective. Examples of parts which are consumed, or used up, during normal Product operation include, but are not limited to, brake pads and linings, clutch linings, blades, reels, rollers and bearings (sealed or greasable), bed knives, spark plugs, castor wheels and bearings, tires, filters, belts, and certain sprayer components such as diaphragms, nozzles, and check valves, etc.
- Failures caused by outside influence. Conditions considered to be outside influence include, but are not limited to, weather, storage practices, contamination, use of unapproved fuels, coolants, lubricants, additives, fertilizers, water, or chemicals, etc.
- Failure or performance issues due to the use of fuels (e.g. gasoline, diesel, or biodiesel) that do not conform to their respective industry standards.

Countries Other than the United States or Canada

Customers who have purchased Toro products exported from the United States or Canada should contact their Toro Distributor (Dealer) to obtain guarantee policies for your country, province, or state. If for any reason you are dissatisfied with your Distributor's service or have difficulty obtaining guarantee information, contact the Toro importer.

- Normal noise, vibration, wear and tear, and deterioration.
- Normal "wear and tear" includes, but is not limited to, damage to seats due to wear or abrasion, worn painted surfaces, scratched decals or windows, etc.

Parts

Parts scheduled for replacement as required maintenance are warranted for the period of time up to the scheduled replacement time for that part. Parts replaced under this warranty are covered for the duration of the original product warranty and become the property of Toro. Toro will make the final decision whether to repair any existing part or assembly or replace it. Toro may use remanufactured parts for warranty repairs.

Deep Cycle and Lithium-Ion Battery Warranty:

Deep cycle and Lithium-Ion batteries have a specified total number of kilowatt-hours they can deliver during their lifetime. Operating, recharging, and maintenance techniques can extend or reduce total battery life. As the batteries in this product are consumed, the amount of useful work between charging intervals will slowly decrease until the battery is completely worn out. Replacement of worn out batteries, due to normal consumption, is the responsibility of the product owner. Battery replacement may be required during the normal product warranty period at owner's expense. Note: (Lithium-Ion battery only): A Lithium-Ion battery has a part only prorated warranty beginning year 3 through year 5 based on the time in service and kilowatt hours used. Refer to the *Operator's Manual* for additional information.

Maintenance is at Owner's Expense

Engine tune-up, lubrication, cleaning and polishing, replacement of filters, coolant, and completing recommended maintenance are some of the normal services Toro products require that are at the owner's expense.

General Conditions

Repair by an Authorized Toro Distributor or Dealer is your sole remedy under this warranty.

Neither The Toro Company nor Toro Warranty Company is liable for indirect, incidental or consequential damages in connection with the use of the Toro Products covered by this warranty, including any cost or expense of providing substitute equipment or service during reasonable periods of malfunction or non-use pending completion of repairs under this warranty. Except for the Emissions warranty referenced below, if applicable, there is no other express warranty. All implied warranties of merchantability and fitness for use are limited to the duration of this express warranty.

Some states do not allow exclusions of incidental or consequential damages, or limitations on how long an implied warranty lasts, so the above exclusions and limitations may not apply to you. This warranty gives you specific legal rights, and you may also have other rights which vary from state to state.

Note regarding engine warranty:

The Emissions Control System on your Product may be covered by a separate warranty meeting requirements established by the U.S. Environmental Protection Agency (EPA) and/or the California Air Resources Board (CARB). The hour limitations set forth above do not apply to the Emissions Control System Warranty. Refer to the Engine Emission Control Warranty Statement supplied with your product or contained in the engine manufacturer's documentation for details