



MODEL NO. 74021 - 390001 & UP
74101 - 390001 & UP

OPERATOR'S
MANUAL

PROLINE
600-Series Mowing Machine



FOR YOUR SAFETY

Two of the most potentially serious types of accidents involving power mowers are contact with the mower blade and overturning the rider/tractor. To minimize the possibility of having these types of accidents, read

and follow these instructions. Also refer to the Safe Operation Practice in this Operator's Manual for other important safety information.

⚠ DANGER **TO AVOID SERIOUS INJURY OR DEATH**

NEVER MOW SIDE HILL OVER 5°	NEVER MOW UP HILL OVER 10°	NEVER MOW DOWN HILL OVER 15°
		

**• STOP BLADE & BACK SLOWLY IF MACHINE STOPS GOING UPHILL
• KEEP SAFETY DEVICES IN PLACE AND WORKING • NEVER USE WHEN UNDER INFLUENCE OF ALCOHOL OR DRUGS • KNOW LOCATION AND FUNCTION OF CONTROLS • LOOK BEHIND & DOWN BEFORE BACKING • NEVER MOW NEAR PEOPLE OR CARRY PASSENGERS
• AVOID SLIPPERY OR STEEP AREAS • REMOVE POTENTIAL THROWN OBJECTS • SET PARKING BRAKE & REMOVE KEY IF LEAVING MACHINE • USE SAFELY; MACHINE IS NOT A TOY • AVOID SHARP OR SUDDEN TURNS • AVOID BLADE UNLESS BLADE & ENGINE ARE STOPPED • GO UP AND DOWN SLOPES, NEVER ACROSS**

READ OPERATOR'S MANUAL

**ON TOP REAR OF LEFT FUEL TANK
DANGER DECAL PART NUMBER 116469**

RIDER/TRACTOR STABILITY

ALWAYS:

Vehicle stability changes with conditions and is affected by:

- Slope angle and length/bumps/holes, etc.
- Slippery conditions (lawn moisture and length)
- Operator size and position/how loaded/equipment used
- Speed/braking/steering changes
- Operator physical limitations/alertness

- Use good judgement when operating the rider/tractor, especially on slopes.
- Maintain the vehicle in good operating condition.
- Be attentive to changing conditions affecting vehicle stability.

NEVER:

- Operate vehicle on extreme slopes.
- Operate vehicle across slopes.
- Abruptly change speed or direction.

BLADE CONTACT

! DANGER! Mower Blades are Designed to CUT: therefore,

ALWAYS:

- Shut off engine and set parking brake.
- Remove ignition key
- Allow moving parts to stop before dismounting, servicing, or cleaning unit.

NEVER:

- Perform ANY work on the mower with engine running.
- Mow with other people around, especially children.
- Leave mower unattended.



LOCATED ON FRAME PLATE UNDER STEERING WHEEL
DECAL PART NUMBER 79-0370

TORO - WHEEL HORSE Dealer: Please fill in model and engine identification numbers of vehicle and all attachments at time of sale. Remove "Pocket ID" sticker at right and attach it to the back of your dealership business card. Use ball point pen or permanent marker.

Suggested location for large decal:
• under hood
• back of seat (exc. low back)

OWNER'S NAME _____
The numbers below identify your rider tractor and attachments and are needed when inquiring about them or ordering parts.

PLEASE KEEP THIS CARD WITH YOU.

RIDER TRACTOR _____
ENGINE _____
MOWER _____
OTHER _____
OTHER _____

MODEL & ATTACHMENT IDENTIFICATION NUMBERS		BELT & BLADE NUMBERS	
Use when ordering replacement parts			
Rider Tractor# _____	S N _____	Trans. Drive Belt# _____	_____
Engine# _____	Spec. Type _____	Mower Drive Belt# _____	_____
Mower# _____	S N _____	Mower Spindle Kit# _____	_____
Other# _____	S N _____	Mower Blade Kit# _____	_____
Other# _____	S N _____	Bagger Blade Kit# _____	_____
		Lift Tab Kit# _____	_____

MAINTENANCE CHART

MAINTENANCE ITEM	SERVICE INTERVAL
CHECK SAFETY INTERLOCK SYSTEM	BEFORE EACH USE
CHECK ENGINE OIL LEVEL	BEFORE EACH USE
CHECK BATTERY WATER LEVEL	BEFORE EACH USE
CHECK AUTOMATIC TRANS. OIL LEVEL(1)	BEFORE EACH USE
GENERAL EQUIPMENT CONDITION	BEFORE EACH USE
CLEAN ENGINE CHAFF SCREEN	AFTER EACH USE
LUBRICATE DRIVE CHAINS*	EVERY 8 HOURS
CHECK TIRE PRESSURE	EVERY 25 HOURS
CHECK FASTENERS: IN PLACE & TIGHT?	EVERY 25 HOURS
CHECK 8-SPEED TRANS. OIL LEVEL*	EVERY 25 HOURS
CLEAN AIR FILTER/PRECLEANER (2)	EVERY 25 HOURS
LUBRICATE CHASSIS/FRONT WHEELS	EVERY 25 HOURS
LUBRICATE MOWER GAGE WHEELS*	EVERY 25 HOURS
CHANGE ENGINE OIL, B&S and KOHLER	EVERY 25 HOURS
CHANGE ENGINE OIL, ONAN and TORO POWER PLUS	EVERY 50 HOURS
LUBRICATE MOWER SPINDLE(S)	EVERY 50 HOURS
CHECK BRAKE ADJUSTMENT	EVERY 50 HOURS
CLEAN ENGINE EXTERIOR & COOLING FINS	EVERY 50 HOURS
CHANGE AUTOMATIC TRANS. OIL/FILTER*	EVERY 100 HRS/ONCE A YEAR
INSPECT SPARK PLUG(S)	EVERY 100 HOURS
REPLACE ENGINE OIL FILTER	EVERY 100 HOURS
REPLACE AIR FILTER:	
• BRIGGS & STRATTON	EVERY 150-200 HOURS
• ONAN, TORO POWER PLUS	EVERY 200 HOURS
• KOHLER	EVERY 100 HRS/AS NEEDED
REPLACE IN-LINE FUEL FILTER*	ONCE A YEAR

* As applicable - See maintenance section in operator's manual

NOTE

- See operator's manual for detailed instructions.
- Increase frequency of service under extremely dirty/dusty conditions.
- See engine operator's manual for infrequent maintenance items, such as TAPPET ADJUSTMENT and CYLINDER HEAD CLEANING.

- (1) Models with separate transmission & transaxle oil reservoirs - check transmission oil level before each use. Check transaxle oil level every 25 hours.
(2) Models with air filter sensor - service precleaner when indicator light illuminates; replace air filter when service interval becomes noticeably shorter. 88-3200

MAINTENANCE
PART NUMBER 88-3200

DECALS WITH LOCATIONS

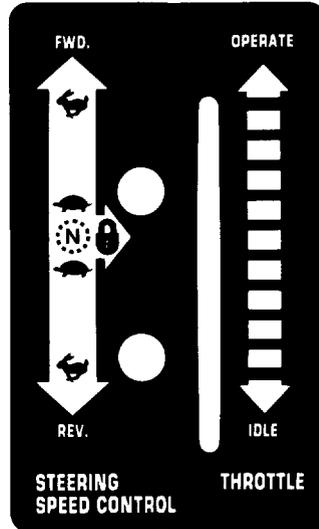

TO RIGHT OF SEAT ON INSTRUMENT PANEL
PART NUMBER 78-2850



ON PTO SWITCH
PART NUMBER 112845



UNDER SEAT AND BACK PLATE
PART NUMBER 88-2790

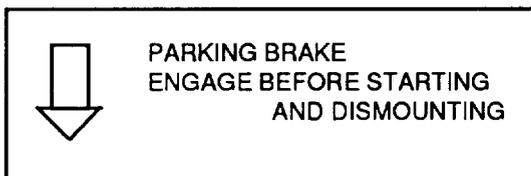

ON PARKING BRAKE LEVER
PART NUMBER 116393



ON FRAME BEHIND RIGHT TIRE
PART NUMBER 115197

CONTENTS

GENERAL SAFETY SUGGESTIONS	I-III	MAINTENANCE	10-17
MACHINE SPECIFICATIONS	1	Maintenance Checklist	10
VEHICLE IDENTIFICATION NUMBER	2	Engine	10
OWNER REGISTRATION CARD	2	Cooling	10
MACHINE CONTROLS	3-4	Oil Quality	10
OPERATING YOUR MACHINE	5-7	Oil Level	10
Safety Intelock System	5	Oil Changes	11
Seat Adjustment	5	Air Filter	12
Correct Engine Operation	5	Crankcase Breather	12
Starting Engine	5	Spark Plug	13
Stopping Engine	6	Carburetor Adjustment	13
Trottle Control	6	Fuel System	13
Choke Control	6	Exhaust System	14
Fuel Recommendations	6	Charging and Electrical Systems	14-15
Oil Specifications	6	Fuse	14
Correct Transmission Operation	6	Battery	15
To Go Forward or Reverse	6	Transmission	15
To Change Speed or Direction	6	Cooling Fans	15
To Stop	6	Machine Lubrication	15
HAND PUSHING MACHINE	7	PTO Electric Clutch/Brake Adjustment	16
CORRECT MACHINE USAGE	8-9	Parking Brake Adjustment	17
Operation of Machine:		Cleaning and Storage	17
With Mower	8	TROUBLESHOOTING CHECKLIST	18
With Drawbar Type Attachments	8	WIRING DIAGRAM	19
With a Rear Vacuum	9		

These symbols mark important instructions relating to your personal safety. To avoid possibility of injury, read and follow such instructions carefully.

⚠ DANGER ⚠ *This symbol warns of extreme immediate hazards which would result in high probability of severe personal injury or death if proper precautions are not taken.*

⚠ CAUTION ⚠ *This symbol warns of a hazard or unsafe practice which can result in personal injury if proper precautions are not taken.*

When manual refers to left or right side of vehicle, it means your left or right when sitting in driver's seat.

SAFE OPERATION PRACTICES — RIDING VEHICLES

GENERAL

1. This machine is capable of amputating hands and feet and can throw objects that can cause injury and damage. **KNOW** the controls and how to stop machine quickly. **READ THIS OPERATOR'S MANUAL** and instructions furnished with attachments. Read, understand, and obey all safety messages appearing on the machine and in the operator's manual. **LEARN** from your operator's manual and from careful **EXPERIENCE** how to operate your equipment correctly. Know your machine's limitations.
2. Keep hands, feet, hair and loose clothing away from attachment discharge area, underside of mower deck or any moving parts while engine is running.
3. The use of drugs or alcohol while operating any equipment will place your safety in peril. Do not attempt operation of this machine while taking drugs or medication or while drinking alcoholic beverages.
4. Only responsible persons with mature judgment and proper physical capabilities should be allowed to operate this machine, and only after instruction in the proper use of this equipment.
5. Do not allow children to operate machine.
6. Do not carry passengers.
7. The purpose of this machine is to perform work. This equipment is not intended for sport or recreation.
8. Do not mow when people or pets are around.

9. Clear work area of objects (wire, rocks, etc.) which might be picked up and thrown.
10. Take all possible precautions when leaving vehicle unattended, such as disengaging power-take-off, lowering attachments, shifting into neutral, setting parking brake, stopping engine and removing key.
11. Watch out for traffic when crossing or near roadways.
12. Machine and attachments should be stopped and inspected for damage after striking a foreign object. Damage should be repaired before restarting and operating equipment.
13. Do not change engine governor settings or over-speed engine.
14. Wear appropriate protective clothing when operating equipment. Long pants and substantial footwear, not barefoot or open sandals, are essential.
15. Do not operate equipment unless properly seated with feet on footrests or pedals.
16. Keep your eyes and mind on your machine, attachment and the working area. Do not let other interests distract you.
17. Safety switch(es) are intended to stop or prevent starting of engine to help prevent accidents. OPERATOR SHOULD TAKE PRECAUTIONS AND NOT RELY ENTIRELY ON SAFETY SWITCH(ES).
18. Care should be used not to touch equipment or attachment parts which may be hot from operation. Muffler and nearby areas may exceed 150° F. Allow cooling to occur before attempting to maintain, adjust or service.
19. Use of stereo headphones, ear protection or other sound altering/dampening devices may limit your ability to hear warning sounds (horns, shouts, etc.).

FUEL/FIRE PRECAUTIONS

20. Handle gasoline with care — it is highly flammable.
21. Use approved gasoline container. Place container out of reach of children.
22. Use gasoline only as a fuel — never as a cleaner.
23. Never remove fuel cap or add gasoline to a running or hot engine, or an engine that has not been allowed to cool for several minutes after running.
24. Never fill fuel tank indoors. Wipe up spilled gasoline.
25. Open doors if engine is run in garage — exhaust fumes are dangerous. Do not run engine indoors.
26. Do not fill machine with gasoline while smoking or when near open flame or sparks.
27. Never store equipment with gasoline in the tank inside a building where fumes may reach an open flame or spark.
28. Allow engine to cool before storing in any enclosure.
29. To reduce fire hazard, keep engine and attachments free of grass, leaves or excessive grease.
30. Battery acid is a poison and can cause burns. Avoid contact with skin, eyes and clothes and

protect your face, eyes and clothing when working around the battery.

31. Battery gases can explode. Keep cigarettes, sparks and flames away from battery.

EQUIPMENT USE AND OPERATION

32. It is recommended that first operation of equipment be done at a slow speed with attachment disengaged. Continue this practice until operator is thoroughly familiar with the controls and has developed operating skills.
33. Disengage all attachment clutches, set parking brake and shift into neutral before attempting to start engine.
34. Disengage power to attachment(s), set parking brake and stop engine before leaving operator position.
35. Disengage power to attachment(s) and stop engine before making any repairs or adjustments.
36. Disengage power to attachment(s) when transporting or not in use.
37. Disengage attachment clutch before attempting to remove the mower from a hole or other obstruction.
38. Disengage power to attachment(s) before backing. Do not mow in reverse unless absolutely necessary and then only after careful observation of the entire area behind the machine.
39. LOOK behind machine to make sure the area is clear before placing the transmission in reverse and continue looking behind while backing.
40. Always back up loading ramps and tilt bed trailers.
41. The parking brake is designed to hold tractor in place at rest, with engine off. Parking brake **will not** restrain tractor with engine running and transmission engaged.

STABILITY/TIPOVER/TRACTION

42. Know the terrain on which you are operating your equipment. There are areas on which your equipment can not be safely operated.
43. Avoid operating equipment on hillsides, slopes or rough terrain. DO NOT operate machine on hillsides or slopes exceeding 15° (27% grade). If safety is in doubt — **STAY OFF THE SLOPE.**
44. Reduce speed and exercise extreme caution on slopes above 10° (18% grade) to prevent tipping or loss of control. Never mow uphill on these slopes — mow downhill only. If a steep hill must be ascended, back up the hill, and drive forward down the hill, keeping tractor in gear. If necessary to turn on hill, always turn downhill.
45. Mow up and down the face of slopes greater than 5° (9% grade), never across the face. Be especially cautious when changing directions on all slopes.
46. Operate your machine smoothly and at a ground speed slow enough to insure complete control at all times. Avoid erratic operation and excessive speed.
47. Sharp turns on any terrain may cause loss of control. Reduce speed and use caution when making sharp turns.

48. Do not stop or start suddenly when going uphill or downhill. Avoid uphill starts. If machine is stopped going up a slope, turn the attachment off and back slowly down the slope keeping the machine in gear. Do not stop or change gears (speed) on slopes.
49. Know the terrain on which you are working. Find hidden obstacles by walking through and inspecting the area prior to operating your equipment in that area. Plainly mark obstacles, such as rocks, ruts or holes and **stay well clear of these obstacles** when operating.
50. While operating, stay alert for holes, rocks or roots, which may cause damage to equipment or upset. Keep at least 3 ft. away from drop-offs, ditches, creeks, culverts, washouts and public highways.
51. Exercise care when mowing around a fixed object to prevent the equipment or attachment from striking the object. When mowing never deliberately run over any foreign object.
52. Areas wet with dew, rain or snow will be more slippery than when dry. Areas covered with loose gravel are more slippery than firm dry ground. Greater stopping distances are required in these slippery areas.
53. Learn to expect changes in operating conditions. Adding or removing attachments or weight to your equipment will make your machine perform differently. Rain, snow, loose gravel, wet grass, etc., change the tractive conditions of the terrain requiring changes in your operating technique, which may include a decision not to operate on that terrain.
54. Use care when pulling loads or using heavy equipment.
 - A. Use only approved drawbar hitch points.
 - B. Limit loads to those you can safely control.
 - C. Do not turn sharply. Use care when backing.
 - D. Use counterweight(s) or wheel weights when suggested in operator's manual.
60. When using machine with snowthrower and auger becomes plugged or jammed:
 - A. Declutch snowthrower and stop tractor engine immediately.
 - B. Disconnect spark plug wire(s).
 - C. Clear snow from discharge chute if plugged.
 - D. If auger is jammed, remove foreign object and repair any damage to snowthrower before continuing.
 - E. Reconnect spark plug wire(s) and resume operation.
61. Never permit anyone to stand near snowthrower auger or discharge opening. Objects may be present in snow, which when thrown, could cause injury.
62. When using snow/dozer blades:
 - A. Avoid hitting solid objects. This can damage blade and injure operator.
 - B. Always travel at a safe, slow speed.
63. Keep all persons a safe distance away when operating tillers. Always disengage the PTO, lower the attachment and remove the ignition key before making any adjustments.
64. If tiller starts to push tractor, disengage PTO clutch immediately.
65. Use chains, counterweight(s) or wheel weights when suggested in the operator's manual.

MAINTENANCE

ATTACHMENT USE

55. When using attachments never direct discharge of material toward bystanders nor allow anyone near vehicle while in operation.
56. When using machine with mower:
 - A. Mow only in daylight or in good artificial light.
 - B. Never make a cutting height adjustment while engine is running if operator must dismount to do so.
 - C. Shut engine off when unclogging chute.
 - D. Check blade mounting bolts for proper tightness at frequent intervals.
57. Keep hands and feet away from rotating blade(s) underneath mower deck. Never place foot on ground when mower is engaged or when mower is in motion.
58. DO NOT operate mower attachment without the chute deflector or complete bagger in place.
59. Exercise care while maneuvering with grass catcher. Front to rear stability may change.
66. Keep all nuts, bolts, fasteners and screws tight to be sure equipment is in safe working condition and check them frequently. Repair or replace worn, damaged, distorted or broken parts as needed.
67. Keep vehicle and attachments in good operating condition and keep safety devices in place and working.
68. Under normal usage, grass catcher bag material is subject to deterioration and wear. It should be checked frequently to determine need for bag replacement.
69. Use only genuine Wheel Horse replacement parts to assure that original standards are maintained.
70. Shields, deflectors, switches, blade controls and other safety devices must be in their proper position and functional.
71. Do not operate without muffler or tamper with the exhaust system. Damaged mufflers or spark arresters can create a fire hazard. Periodically inspect and replace if necessary.
72. If equipment begins to vibrate abnormally, disengage power to attachments and stop engine at once. Repair any damage before starting or continuing operation.
73. Periodically inspect all shafts, levers, friction devices and other moving parts subject to wear. Make required adjustment or replace these parts if damaged, distorted or broken, or as soon as wear affects the normal operation of the vehicle or attachment. DO NOT operate equipment that is not functioning properly.

SPECIFICATIONS:

ENGINE:

MACHINE MODEL	ENGINE MODEL*	RATED H.P.**	DISPLACEMENT cu. in./cc	BORE in./mm	STROKE in./mm	IGNITION
616-Z	P-216V-I/11103D	16	43.3/710	3.25/82.6	2.62/66.6	Electronic
620-Z	P-220V-I/11104OD	20	47.7/782	3.25/82.6	2.88/73	Electronic

*Basic engine model number shown; type and serial numbers from engine I.D. plate are required to completely identify engine.
 **Engine manufacturer's rating at 3600 RPM

TRANSMISSION:

TYPE: HYDROSTATIC

APPROXIMATE GROUND SPEEDS (at Full Throttle)

FORWARD - Variable 0-7.2 mph (11.6 kph)
 REVERSE - Variable 0-7.2 mph (11.6 kph)

ELECTRICAL SYSTEM:

616-Z, 620-Z MODELS

Type: 12 Volt D.C., Negative Ground
 Alternator: 12 Volt, 20 amp. Regulated
 Battery: 12 Volt, 280 CCA

TIRES:

	SIZES - FRONT	SIZES - REAR	PRESSURE - FRONT	PRESSURE - REAR
616-Z, 620-Z	11x 4.00-5	18 x 9.50-8	8 psi (.57 kg/cm ²)	8 psi (.57 kg/cm ²)

PHYSICAL DATA:

MODEL	HEIGHT	LENGTH	OVERALL WIDTH	WHEEL BASE	INSIDE TURNING RADIUS	NET WEIGHT (Approximate)
616-Z, 620-Z	41.2 in. (104.9 cm)	71.9 in. (182.6 cm)	40 in. (101.6 cm)	42 in. (106.7 cm)	0 in. (0 cm)	590 lbs. (268 kg)

TUNE-UP/GENERAL MAINTENANCE SPECIFICATIONS:

ENGINE:

MACHINE MODEL	POINT GAP in./mm	TIMING MARK LOCATION	IGNITION TIMING (BTDC)	SPARK PLUG TYPE	SPARK PLUG GAP in./mm	DIRECTION OF ROTATION	IDLE RPM (No Load)	GOVERNED MAX. RPM (No Load)
616-Z, 620-Z	N/A	N/A	Fixed	RS14YC*	.025/.64	Counterclockwise	1400	3600

* Or equivalent (Champion number shown)
 ** Or equivalent (NGK number shown)

LUBRICANT/FUEL CAPACITIES:

	CRANKCASE:	FUEL TANK:	CHASSIS:
616-Z,	1.7 qts. (1.6 l) w/o Filter	3 Gallons (11.2 l)	Grease Fittings : 6
620-Z	2.0 qts. (1.9l) w/ Filter		

MODEL AND SERIAL NUMBER LOCATION

Model and Serial numbers are used to identify your new machine and attachments. These numbers should always be referred to when consulting your dealer or factory concerning service, parts, or other information you may require.

The machine model and serial number plate is located on left side of frame next to engine. Engine identification number is located on engine shrouding, and indicates model, type number and serial number of your machines engine.

For your convenience and ready reference, enter machine and engine numbers below.



Machine Model and Serial Number

MODEL AND SERIAL NO.		
0	THE TORO CO.	0
MINNEAPOLIS, MN. 55420		

Engine Identification Number

Model _____

Type No. _____

Code No. _____

OWNER REGISTRATION AND WARRANTY

A TORO Registration Card is supplied with each product. Completion of the required information and submission of the card to the TORO Company is essential to insure proper notification should your product be the subject of a safety rework program. The owner's copy of the Registration Card can also be used for warranty and purchase date verification.

MACHINE CONTROLS

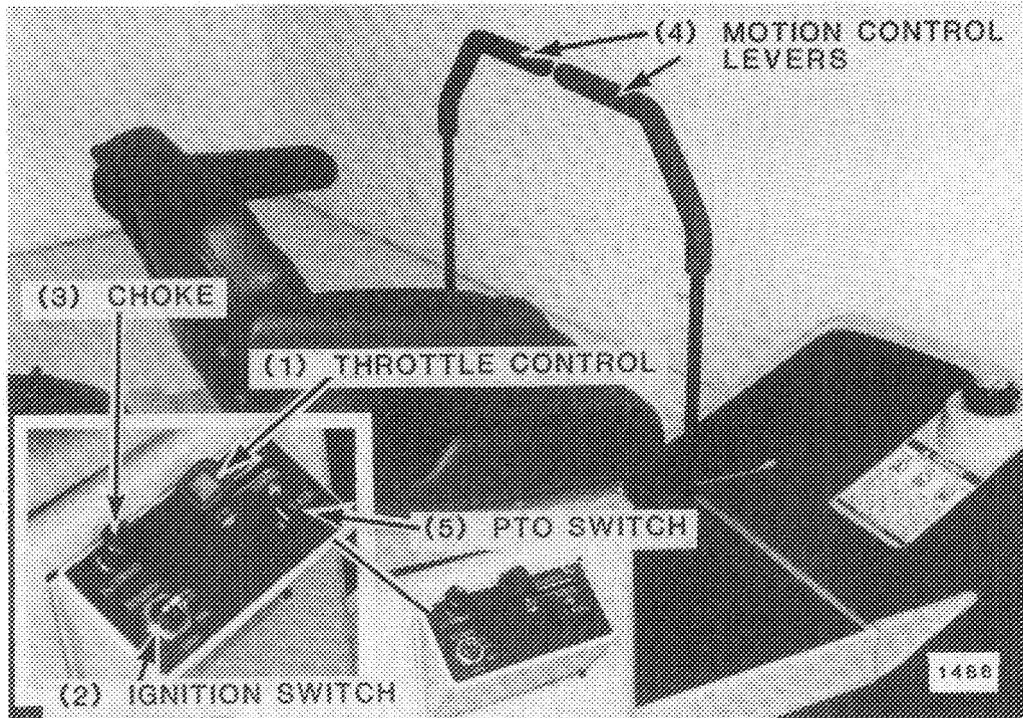

1. THROTTLE CONTROL

Throttle is located on top of right panel below seat. Move throttle forward all the way to operate position to operate machine. Move throttle all the way to rear position before shutting engine off.

2. IGNITION SWITCH

Ignition switch is located on right panel below seat. Ignition switch has three positions: (1) Off, (2) Run, (3) Start. To start engine turn key all the way to Start. Release key when engine starts and it will automatically return to Run position. Turn switch to Off position to stop engine.

3. CHOKE CONTROL

Choke Control is located on right panel next to ignition switch. Pull choke knob out when starting engine. Slowly push knob in after engine starts. If engine is warm and has been running, choking may be necessary to restart engine.

4. RIGHT AND LEFT MOTION CONTROL LEVERS

Right and left levers control speed and direction of drive wheels independently. Levers swing out from neutral to park position. To enter or exit seat, swing levers outward into park position. When levers are in parked position they can not be moved.

5. PTO (POWER TAKE-OFF ELECTRIC CLUTCH/BRAKE SWITCH

PTO switch is located on right panel below seat. Mower is engaged and disengaged with PTO switch.

To engage PTO, pull up on back of cover and move toggle switch forward. To disengage PTO, push down on back of switch cover. This will move switch to "OFF" position. Switch must be in OFF position to start engine.

6. PARKING BRAKE LEVER

Parking brake lever is located on left side below seat. To engage parking brake, place motion control levers in neutral position and move brake lever back. To disengage parking brake move lever forward.

Parking brake must be in engaged position to start engine.

7. HOUR METER

Hour meter is located on back of seat support in front of engine. Hour meter is a gauge indicating operating hours of tractor.

8. FUEL TANK VALVE

Fuel tank valve is located at bottom of tank. Fuel valve is normally left open except when service on fuel system becomes necessary.

MACHINE CONTROLS

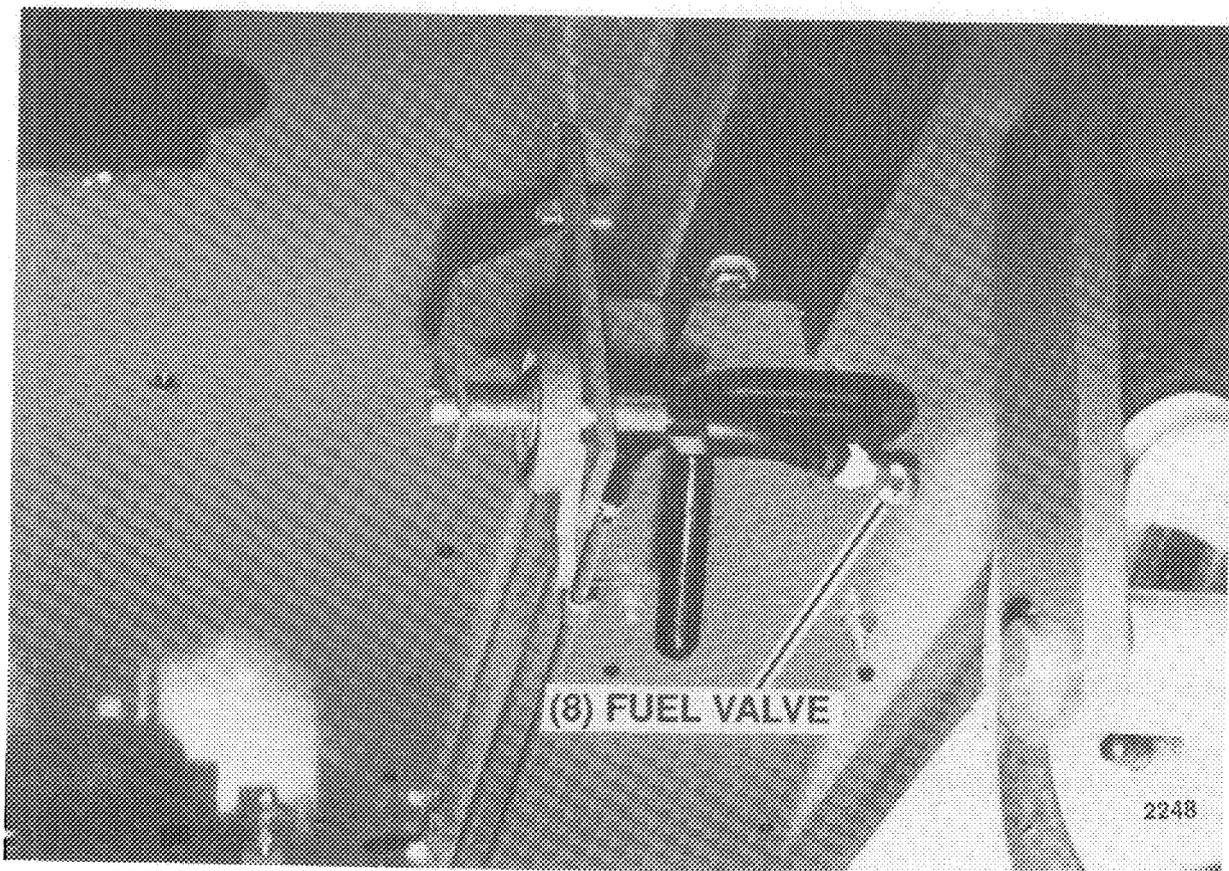
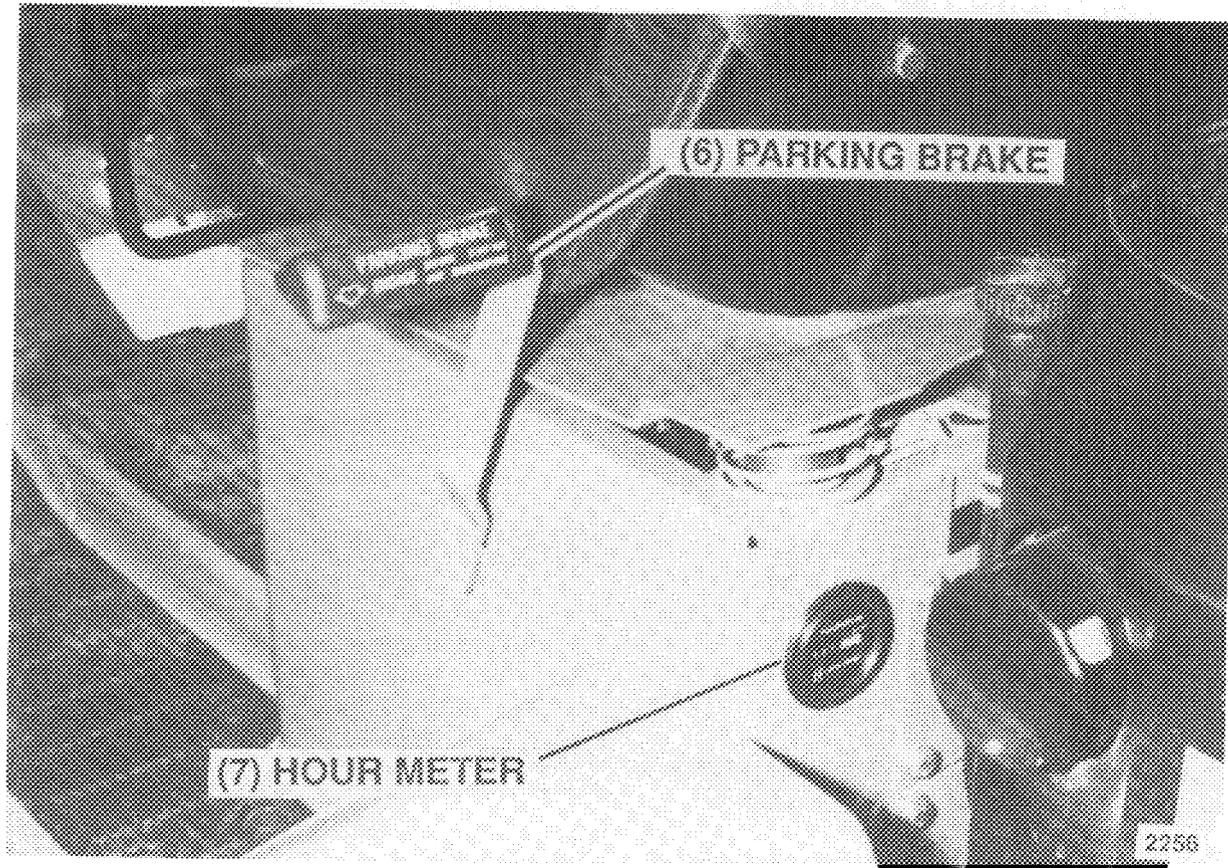

SAFETY INTERLOCK SYSTEM

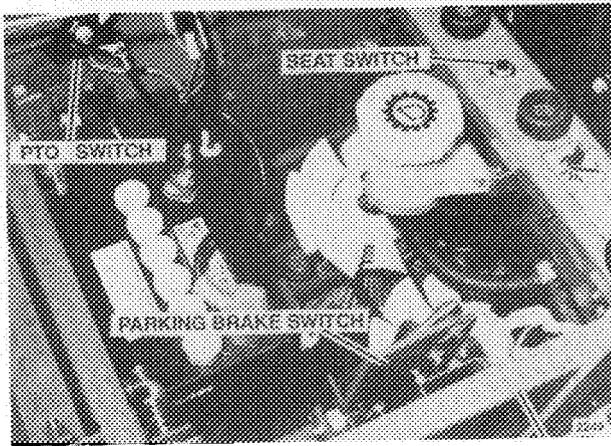

Safety Interlock Switches

Each machine has two interlocks switches for safe and a seat that shuts engine off when driver raises off seat. PTO switch must be "OFF" and parking brake engaged before engine will start. Seat switch will stop engine when seat is vacated with PTO switch in "ON" position, or if parking brake is not set.

If machine will not start, check that parking brake is engaged and PTO switch is in "OFF" position.

Safety interlock system must be tested periodically. To test operation, following functions must be observed. If not, immediate repairs must be performed by an Authorized Toro Wheel Horse Dealer for your protection.

1. Engine should **NOT** start if:
 - a. Parking brake is engaged.
 - b. PTO switch is "ON".

Test each of the above-one at a time.

2. With engine running and PTO switch in "ON" position, test operate seat switch by rising off seat. Engine should shut off.
3. With engine running, PTO "OFF" and parking brake disengaged, test operate switch by raising off seat. Engine should shut off.

SEAT ADJUSTMENT

Seat can be adjusted for optimum operator comfort.

1. Loosen two knobs.
2. Slide seat to desired position.
3. Tighten knobs.

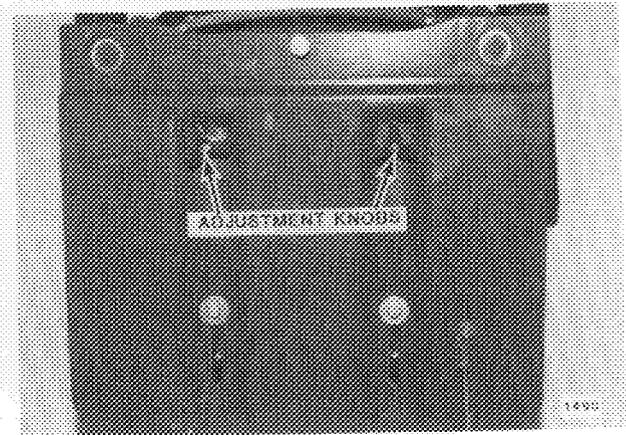

Seat Adjustment

CORRECT ENGINE OPERATION



Before starting engine, become familiar with all controls. Read this Operator's Manual thoroughly. always check engine oil level before starting engine.



Care should be taken to avoid inhaling exhaust gases as they contain carbon monoxide gas which is colorless and odorless. Carbon monoxide is a dangerous gas that can cause unconsciousness and is potentially lethal. Do not run engine in confined areas such as a closed garage.

Starting Engine

Because of a built-in safety interlock system, your machine will not start unless parking is engaged and PTO switch is "OFF".

To start engine, engage parking brake. Move throttle control lever to low idle position. Pull choke control all the way out to Cold position. Turn ignition key to Start position to engage starter. When engine starts, release key. Switch is spring loaded and will return to Run position automatically.

IMPORTANT: If engine fails to start after 10 seconds of continuous cranking, turn key to OFF position and allow starter motor to cool. Check for cause of hard starting; consult Troubleshooting Checklist.

Once engine has started, raise throttle to half position and lower choke. If engine stalls at low

speeds, or hesitates during acceleration, choke should be applied as necessary until engine reaches normal operating temperature.

Stopping Engine

To stop engine; move throttle lever to Idle position and turn ignition key to "Off" position. If engine has been working hard or engine is hot, allow engine to idle a short time before turning key off. This practice will help cool engine before stopping.

Note: In case of emergency engine may be stopped by turning ignition key to "Off" position.

⚠ CAUTION ⚠

Always remove key and set parking brake when leaving machine unattended, even if for just a few minutes. Prevent accidents; don't give children or unauthorized persons an opportunity to operate this machine.

Throttle Control

Throttle control regulates speed of engine as measured in RPM (Revolutions Per Minute). This control **Should not** be used to regulate ground speed.

Engine has been designed with a special governor that limits engine RPM. Unlike an automobile, this governor allows engine to operate most efficiently at a set speed and protects it from damage caused by excessive RPM. Always operate machine with throttle control set at full speed.

Choke Control

Choke control activates a "butterfly" valve in carburetor. When choke is partially or completely closed, less air is admitted to engine. This results in a higher fuel-to-air (richer) mixture that is easier to ignite when engine is cold. Choking engine is required when engine is started cold. Warm engines may not need choking.

Fuel Recommendations

⚠ DANGER ⚠

Ignition of fuel can cause serious personal injury or death by fire or explosion., Do Not permit any flame, cigarette, or other igniter near fuel system. Handle fuel with care - it is highly flammable.

Use clean, fresh, unleaded gasoline. Regular leaded gasoline may also be used, but is not a preferred fuel. Do not use highly leaded premium gasoline. Use of unleaded gasoline results in less maintenance.

IMPORTANT: Do not use gasoline de-icers. Gasoline de-icers can cause internal damage to carburetor and fuel pump parts. Do not use fuels containing ethanol concentrations greater than ten percent. Fuel containing alcohol may cause poor engine performance and internal engine damage.

If regular leaded gasoline is used continually, carbon and lead deposits should be removed from cylinder heads as required because of engine power loss. Unleaded gasoline may be used safely after lead deposits have been removed.

⚠ DANGER ⚠

Spilled fuel can ignite and cause serious personal injury or death. Never fill fuel tank when engine is running. Fill fuel tank outdoors with extreme care. Never fill fuel tank indoors. Replace gasoline cap securely and wipe up all spilled fuel.

Oil Specification

To protect your machine's engine check engine oil level before each use. Complete information concerning recommended oils and how to check oil level is given in "Maintenance" section of this manual.

CORRECT TRANSMISSION OPERATION

Machine is equipped with a sperate transmission for each rear wheel. Transmissions are controlled with "Motion Control Levers", one for each wheel.

Motion control levers vary forward and rearward ground speed of each wheel independently. Levers are in neutral position at mid-way travel of levers. Levers are spring loaded and will return to neutral when released. When motion control levers are moved from neutral to outside of machine, they are in park (locked) position.

To maintain enough power for machine traction and mowing, regulate motion control levers to keep engine rpm high and somewhat constant. A good rule to follow is: decrease ground speed as load on cutting blades increases or more traction is required and increase

ground speed as condition decreases. This allows engine, working with transmissions, to allow proper ground traction while maintaining high blade tip speed necessary for good quality-of-cut.

 CAUTION 
Always move motion control levers slowly. Sudden starts can be damaging to equipment and could cause loss of operator control, roll-over or personal injury.

To Go Forward or Reverse

To enter seat, move motion control levers to park position. Make sure parking brake is set and start engine. Move levers to neutral position and release parking brake. Slowly move both levers in direction you want to go evenly. Farther levers are moved away from neutral, faster machine will travel.

To Change Direction

To change direction of machine, slowly move levers to neutral and slowly move both levers in direction you want to go.

To Make a Gradual Turn

Slow machine down by moving levers toward neutral evenly. Slightly slow down speed and left wheel to turn left or slightly slow down speed of right wheel to turn right.

To Make a Zero Turn

Move both motion control levers evenly to neutral. Slowly move on wheel forward and opposite wheel rearward at the same time. Practice turning in a low visibility hard surface area before trying to turn on a lawn surface.

To Stop

To stop machine, return both levers evenly to neutral position. To dismount machine, set parking brake, move motion control levers to park position, shut-off engine and dismount machine.



Transmission Push Valve Levers

HAND PUSHING MACHINE

IMPORTANT: Hand push machine only. Do not tow. Towing can cause severe damage to transmission.

Machine can be pushed at a slow speed. Transmission push valves are located under main frame in front of rear wheels. To release push valves in each transmission, lift levers up and to the right into lock positions. To resume operation of machine, release levers so that levers are in lowered position.

CORRECT MACHINE USAGE



Read manuals provided with attachments before operating. These manuals give a detailed description of operation and point out other areas of caution. Familiarize yourself thoroughly with equipment before attempting to use it.

OPERATION OF MACHINE:

WITH MOWER

IMPORTANT

Keep all shields and mower discharge chute in place. Never attempt to clear discharge areas or mower blades without disengaging mower and removing ignition key.

IMPORTANT

Each time mower is installed, check for proper operation of PTO clutch and brake.

For best operation on average lawns, operate engine at full throttle, control ground speed with transmission. Uneven cutting is often a result of excessive ground speed. To correct, reduce ground speed. Average lawns are usually cut at a height between 2 and 3 in. (5-7.6 cm). Tall grass and weeds should be cut with mower in its highest position, making a second pass cutting to height desired. Always keep mower blades sharp.

Mowing Speed

Mower is designed to operate most efficiently at maximum blade speeds. Speed of machine should allow mower blades to maintain this maximum speed while mowing across turf. Slow machine for cutting tall grass, grass which is heavy with moisture, or when moving uphill. If ground speed is too fast, or blade speed is too slow, mowing will be uneven because mower blades will not be able to lift grass into cutting position as mower passes over ground.

Mowing Height

Best cutting height for your lawn has probably

been established from previous experience. First time you mow, set mower to cut a little higher than you have in the past. This will help you determine best approach to uneven areas, to be sure wider cut does not result in scalping high spots.

When cutting very tall or damp grass, set mower in its highest cutting position and enter area slowly. If necessary, take a cut on half width of mower, overlapping previously cut area on each pass. Then, with mower set to desired height, make a finish cut over entire area.

Mowing Pattern

Machine will cut an area quickly and efficiently if mowing pattern is planned to take full advantage of machines capabilities. Use a pattern that will permit as much continuous forward motion and long straight runs as possible. Avoid necessity of repeated tight turns whenever you can by swinging wide over previously cut areas at ends of each pass. Progressive system illustrated below can be used on most lawns and eliminates tight turns and constant direction changes. Leave tight corners and close trimming until last.

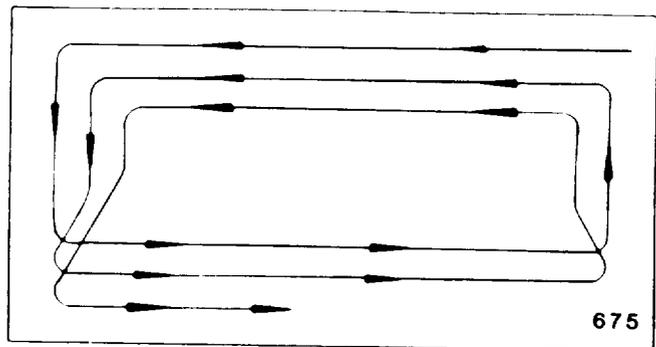

Efficient Mowing Pattern

WITH DRAWBAR TYPE ATTACHMENTS

Many attachments simply use machine as a towing vehicle. They are attached or removed from machine by installation or removal of a single drawbar hitch pin.

Some of these attachments are powered by a separate gasoline engine, some are "ground driven" and some are simply towed, such as a lawn sweeper or dump cart.

In any case, all these attachments should be approached with same amount of caution given any mechanical device. Always read each "Operating Instruction Manual" carefully before attempting to use attachment. Keep children and pets away from machine when in operation. Never allow any unauthorized personnel to operate equipment.

 **CAUTION** 

TORO Wheel Horse recommends following load limits be observed when using machine with a dump cart. Load limits have been set to provide for safe braking on slopes.

275 lbs. (127 kg)

MAINTENANCE



To minimize chance of injury, perform all maintenance and adjustments on your machine with engine off and ignition key removed, unless instructed otherwise in this section. Use extreme care when working near operating machinery. Do not wear loose fitting clothing. Remove watch and jewelry before beginning work and observe common safety practices when using tools.

MAINTENANCE CHECKLIST

	Before Each Use	After Each Use	Every 25 Hours	Every 50 Hours	Every 100 Hours	Every 200 Hours/1 Year(2)	Every 1000 Hours
NOTE: These service intervals are considered MAXIMUM under normal conditions. Increase frequency under extremely dirty or dusty conditions.							
SERVICE OPERATION							
CHECK:							
Safety Interlock System	X						
Engine Oil Level	X						
Battery Water Level (3)			X				
Auto. Trans. Oil Level	X						
General Unit Condition	X	X					
Parking Brake Adj.					X		
Tire Pressure(3)			X				
Fasteners Placed & Tight			X				
PTO Electric Clutch & Brake Adjustment					X		
CLEAN:							
Air Filter/Pre-cleaner			X				
Engine Chaff Screen	X						
Engine Exterior & Fins				X			
Breather Valve & Baffle							X
Cylinder Head Deposits							X
REPLACE:							
Engine Oil Filter					X		
Spark Plugs					X		
Air Filter (2)					X		
In-Line Fuel Filter					X	X	
LUBRICATE:							
Chassis		X					
CHANGE:							
Engine Oil (1)			X				

Refer to Engine Owner's Manual for Applicable Information Concerning:

- Adjustments
- Special Cleaning Instructions
- Recommended Dealer Maintenance

- Refer to text for initial service interval for new tractors.
- Which ever occurs first.
- Or monthly

ENGINE

Cooling

Check chaff screen on engine every time machine is used. Restricted air flow through engine can cause overheating and engine damage.

Oil Quality

For maximum engine protection under all operating conditions use API Service Classification SF oil. This letter will appear on oil can.

Oil Level

Form a habit of checking oil level regularly.

Check oil level of engine every 8 hours or before each use. An improper oil level can cause extensive internal damage to engine.

Oil filler dipstick and oil drain location for engine is illustrated in following illustrations.

To check engine oil level, stop machine where engine is level. Shut off engine, set parking brake, and remove ignition key.



Crankcase pressure can blow out hot oil and cause serious burns. Do NOT check oil while engine is operating.

Remove oil dipstick from engine.

CHECK OIL

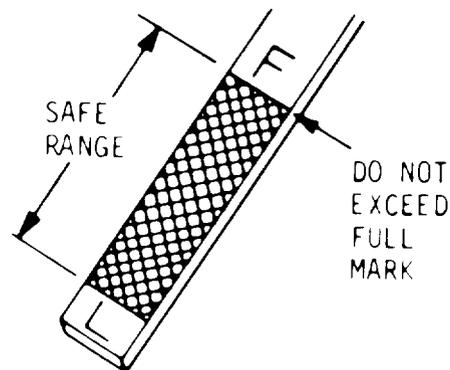

Correct Oil Level

Wipe dipstick with a clean lint free rag; reinstall

676

dipstick into block all the way. Remove dipstick again and read scale on lower portion of stick.

Add oil through oil dipstick tube.

Oil Changes

Engine oil in your machine should be changed after first 25 hours of operation. Thereafter, oil should be changed at 50 operating hour intervals. Oil filter should be changed every 100 hours. If operating conditions are extremely dusty or dirty frequency of oil changes should be increased.

Failure to change engine oil at recommended intervals can lead to serious damage to engine. This is especially true when using detergent oils which are designed to hold impurities in suspension; when saturation point is reached, oil may suddenly break down to form a gelatin-like substance which seriously impairs and can even stop flow of oil. Increase frequency of oil changes if machine is operated under extremely dusty conditions.

Before changing oil, start engine and allow it to warm up. This will allow oil to flow easier. Shut off engine and remove key.

To drain oil:

Remove drain plug. After oil has drained completely, reinstall drain plug.

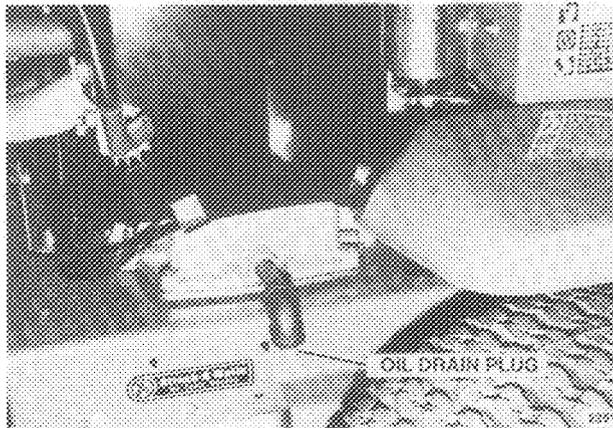

Engine Oil Drain



Engine Oil Dipstick/Fill Tube and Filter

If oil filter is to be replaced, unscrew used filter and install new filter on engine.

Remove dipstick/oil fill cap and add about 80% of amount of oil specified in following chart. Also shown are charts for selecting correct oil type and oil viscosity. When using temperature - viscosity chart, select air temperature most likely to be encountered within next 50 hours of operation.

ENGINE OIL CHANGE Crankcase Oil Capacity

1.75 qts. (1.6l) w/o Filter
2 qts. (1.9l) w/Filter

ENGINE OIL TEMPERATURE - VISCOSITY CHART

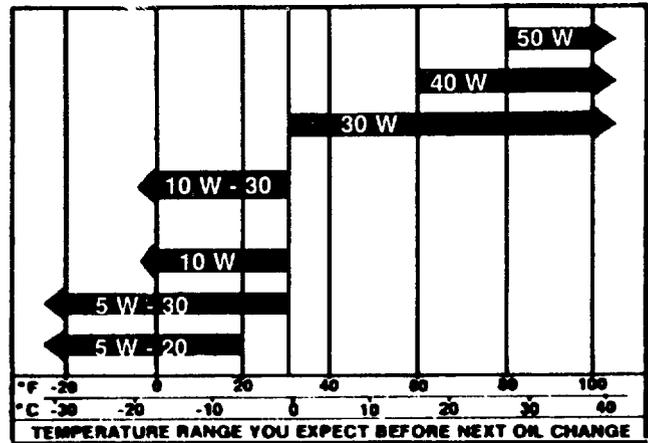

ENGINE OIL TYPE
API Service SF or SF/CC

After adding 80% of prescribed amount of oil, check oil level. Add oil as necessary to bring oil to "Full" level.

Air Filter

Dirt induced through improperly installed, poorly serviced, or inadequate air filter elements, is more often cause of a worn out engine than long hours of operation. A small amount of dirt will destroy a set of piston rings in a matter of hours. A clogged element causes a richer fuel mixture which wastes gasoline, and may lead to formation of harmful sludge deposits.

Clean engine air filter after every 25 hours of operation (more often if machine is operated under extremely dusty conditions).

Replace filter elements at 200 hour intervals. Replace more frequently in dusty operating conditions. To protect your engine, use only manufacturer's replacement filter, or replacement filter with equivalent specifications.

Check following when installing a new or serviced element:

1. Base must be securely tightened to carburetor. Replace base if bent or cracked.
2. Gasket surfaces of element must be flat against base and cover to seal effectively.
3. Tighten screws securely.
4. Be sure cover seals and gaskets are in good condition. Bad gaskets and seals can let in unfiltered air into carburetor.

IMPORTANT

To prevent any dirt or other contaminants from entering engine, always cover carburetor air horn when air cleaner is removed.

Dry type air filter element is cleaned by tapping it lightly on a flat surface to remove loose dirt particles. Replace element if dirt does not drop off easily. **DO NOT** wash elements in liquid. **DO NOT** attempt to blow dirt off with compressed air as this can puncture filter element.

Foam precleaners are used over filter elements. Clean precleaner at 25 hrs. Wash precleaner in a

solution of liquid detergent and water. Squeeze out excess water and allow it to dry. Coat pre-cleaner evenly with SAE30 oil. Knead into and wring out excess oil from pre-cleaner.



Precleaner service - wash, squeeze dry, coat with oil & wring out

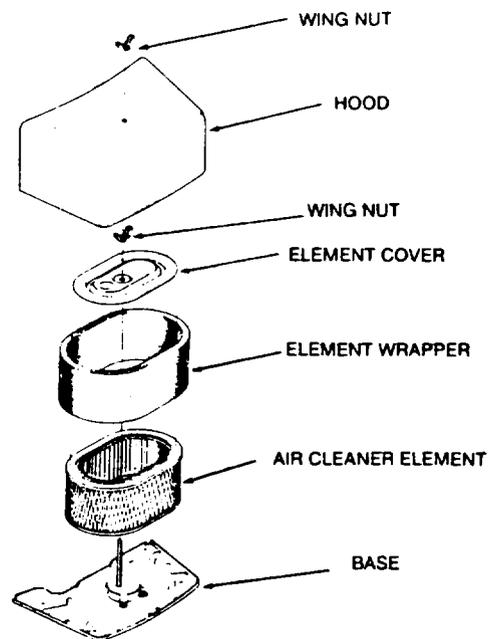

Air Cleaner Assembly

CRANKCASE BREATHER

Engine uses a crankcase breather valve and "Pack" for maintaining crankcase vacuum. If crankcase becomes pressurized as evidenced by oil leaks at seals, clean pack and valve screens in

a suitable solvent. Check and clean valve and baffle every 1000 hours of operation.

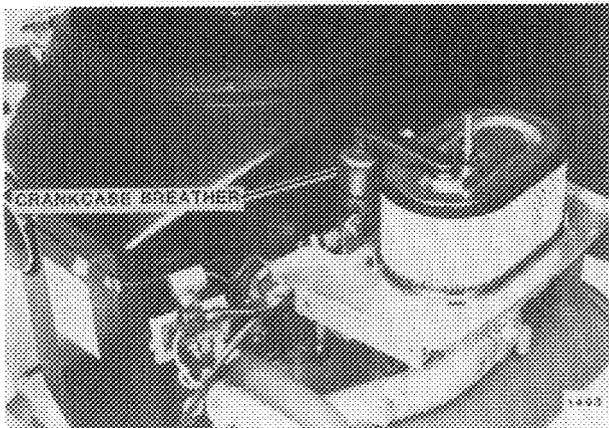

Crankcase Breather

Spark Plug

Engine misfires, or generally poor operation, is often caused by spark plugs in poor condition or incorrect spark plug gap setting. Replace spark plugs at 100 operating hour intervals. Also replace spark plugs if inspection reveals fouling or excessive deterioration.

Always clean area around spark plugs before removing them to prevent dirt from entering engine. Use a spark plug wrench to remove and install plugs.

Check condition of plug(s). Good operating conditions are indicated by a light coating of gray or tan deposit. A dead white, blistered coating could indicate engine overheating. A black coating could indicate an "overrich" fuel mixture caused by a clogged air cleaner, or improper carburetor adjustment.

Replace spark plugs that are not in good condition. **Never sandblast, wire brush, scrape or otherwise service a spark plug in poor condition. Best results are obtained with a new plug.**

Always check spark plug gaps before installing a new plug or reinstalling original plug. Use a spark plug gap gauge to adjust electrode air gap. Refer to Specifications section for settings.

Carburetor Adjustment

Carburetors are adjusted at factory and should not have to be reset. If however, one of following conditions is noted, carburetor should be readjusted immediately as continued operation with incorrect setting can lead to fouled spark plugs, overheating, excessive valve wear or other problems. If black exhaust smoke is noted, check air cleaner first - an "overrich" mixture is usually caused by a poorly serviced, clogged air cleaner element, not an improperly adjusted carburetor.

CONDITION

- A. Black, sooty exhaust smoke, engine sluggish.
- B. Engine misses and backfires at high speed.
- C. Engine starts, sputters and dies under cold weather starting.
- D. Engine runs rough or stalls at idle speed.

Carburetor Adjustment Chart

Correct carburetor adjustment requires a significant amount of knowledge as well as special equipment. In addition, other adjustments, such as governor settings, may also be necessary after adjusting carburetor. For these reasons, it is suggested that carburetor adjustments be performed by an authorized Wheel Horse dealer.

Fuel System

A fine-mesh screen type strainer, incorporated into fitting at bottom of fuel tank filters foreign matter from gasoline before it reaches carburetor. This strainer requires service only if fuel supply becomes severely contaminated.



Fuel Strainer

Always clean area around fuel cap before removing it to prevent dirt from entering fuel system. Also insure that fuel storage container you are using is clean and in good condition.

Keep fuel tank full during winter operation, cold and damp weather conditions can cause moisture to condense in tank.

Exhaust System

Make regular visible and audible inspections of exhaust system throughout life of machine. Locate leaks in muffler and piping while engine is operating. Repair all leaks immediately after they are detected for personnel safety.



DO NOT inhale exhaust gases. Exhaust gases can result in serious personal injury, even death. Inspect exhaust system for leaks immediately.

CHARGING AND ELECTRICAL SYSTEMS

Alternator

An alternator is used to charge battery. Alternator charging system normally requires no service other than periodically checking that all exposed wiring and electrical connections on machine are clean, tight and in good condition.

IMPORTANT: Proper polarity is critical with an alternator equipped charging system. Always disconnect battery ground cable (negative) before working on any part of electrical system. Verify all components are connected correctly before reconnecting ground cable (negative) or damage to alternator system components will result. Never run engine if battery is removed, or if battery is not connected to charging system. Serious damage to charging system components may result.

ELECTRICAL SYSTEM

Fuses

Three fuses protect machine's electrical system and components from excessive current and short circuits.

Fuses are contained in a fuse holder clipped to machine's frame under seat:

10 amp fuse protects clutch & hour meter.

20 amp fuse protects switch circuit.

30 amp fuse protects charging circuit.

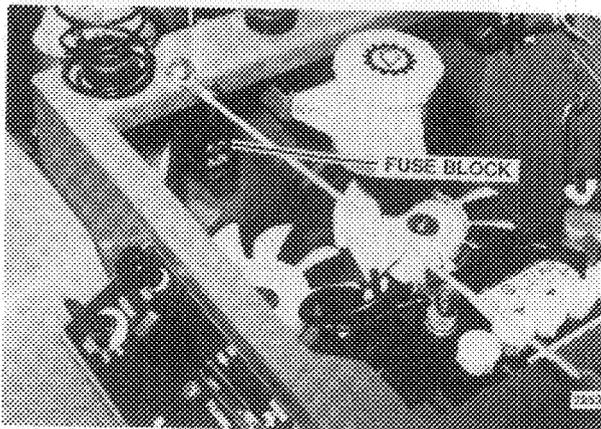

Fuse Locations

A "blown" fuse is an indication of short circuits or current overloads. Refer to wiring diagram in back of this manual and become familiar with machine's electrical system before attempting to troubleshoot.

Battery



When servicing battery or any other part of electrical system, or if battery must be removed for any reason, always disconnect negative (ground) cable FIRST and reconnect it LAST to avoid possibility of electrical shorts.

Batteries produce flammable hydrogen gas. Avoid creating sparks and open flames and do not smoke when working near batteries.

Battery electrolyte solution is poisonous and can be injurious to eyes, skin and clothing. In event of an accident, flush affected area immediately with a solution of one part baking soda to four parts water. Notify physician immediately. If baking soda is not immediately available, flush affected area with water. Notify physician immediately.

Maintain electrolyte level above plates in each cell by adding distilled water as necessary. Best

time to add water is just prior to operating machine so water will mix with solution. Do not overfill battery. Electrolyte solution is corrosive and overfilling can cause damage to surrounding metal parts. Battery should be maintained at 1.265 specific gravity charge. When battery has been out of machine for servicing, take care to connect cables to battery exactly as they were before removal.

For longest service life, battery should be kept clean by wiping it off with a paper towel. Any corrosion around battery terminals should be removed by applying a solution of one part baking soda to four parts water. A light coating of grease may be applied to all exposed terminal surfaces to prevent corrosion.

IMPORTANT

At temperatures below 32°F (0°C), full charge state must be maintained to prevent cell electrolyte from freezing and causing permanent battery damage.

HYDROSTATIC TRANSMISSION

Each rear wheel is controlled by a separate transmission. Lubricant level in both reservoirs should be checked before each use. Check oil levels when oil is **COLD**. Transmission oil level should be at line on reservoir.

IMPORTANT

Use care to prevent dirt, clippings or other foreign material from entering transmission during oil level checks, oil fillings, or oil changes.

Changing oil in transmissions is not recommended except for major service. If oil must be frequently added, a leak is indicated and should be corrected immediately.

For information purposes, oil capacity for each transmission is 1.5 qt. (1.4 l)

Oil specifications are:

SAE 30 A.P.I. Service SC,SD,SE,SF

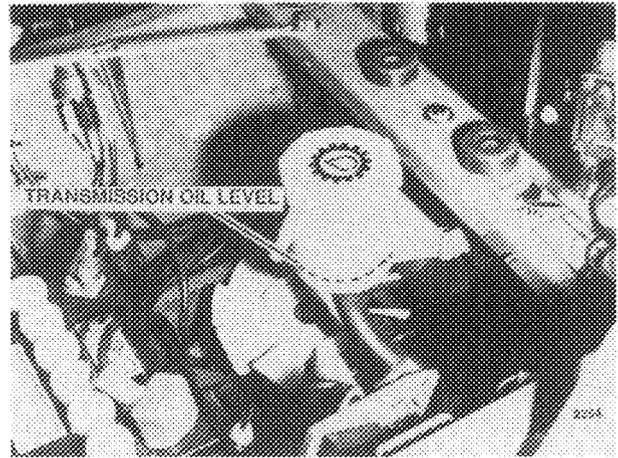

Transmission Oil Level

Cooling Fans

A cooling fan is bolted to each transmission input shaft. Fan forces air over transmission cooling fins to cool transmission oil. Replace cooling fan if it becomes cracked or broken., Be sure to install it so that maximum airflow is directed across transmission.

Cooling fins on transmissions should also be kept clean for best cooling efficiency. Periodically inspect for dirt buildup, and brush or wash out any accumulated dirt or clippings. If pressure washing equipment is used, avoid directing spray at joints and seal areas, to prevent forcing water into reservoir system.

LUBRICATION

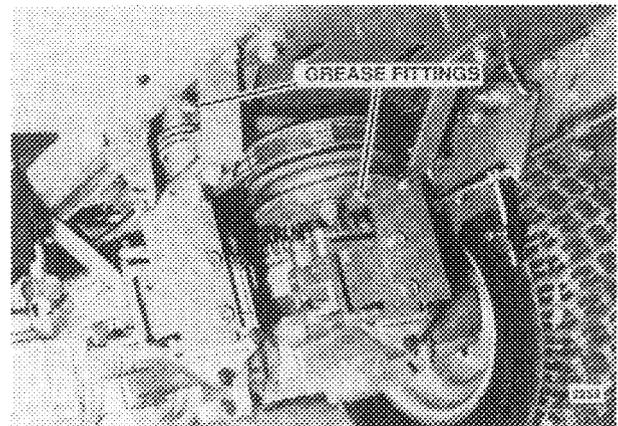

Grease Fittings

Lubricate all grease fittings after each 25 hours of operation with #2 multi-purpose lithium base grease using a pressure grease gun. Other

pivoting arms and levers should be lubricated at same intervals with light machine oil applied directly to wear surfaces. Before applying grease gun, clean zerk fittings carefully to prevent dirt from being forced into fitting. After inserting grease, wipe off any excess grease.

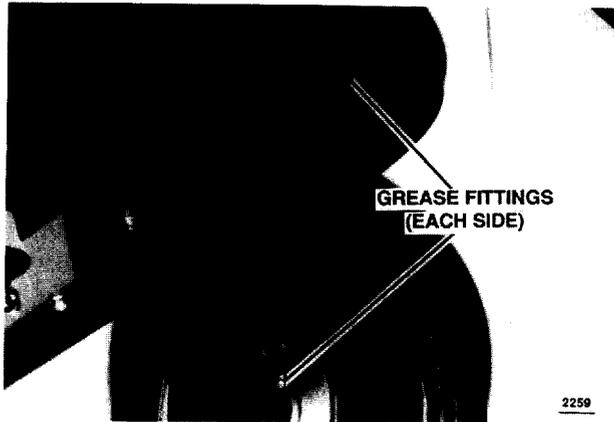

Front Grease Fittings

PTO ELECTRIC CLUTCH/BRAKE

PTO electric clutch/brake may require periodic adjustment due to normal wear of friction surfaces. Check PTO electric clutch/brake adjustment every 100 hours.

To adjust PTO Electric Clutch/Brake:

1. Stop engine, set parking brake and remove ignition key.
2. Clutch has three springs and adjustment nuts. All three must be adjusted equally.
3. Insert a .010" feeler gauge into the three air gap inspection slots, one at a time, and turn adjustment nuts until a small amount of resistance is felt on feeler gauge.

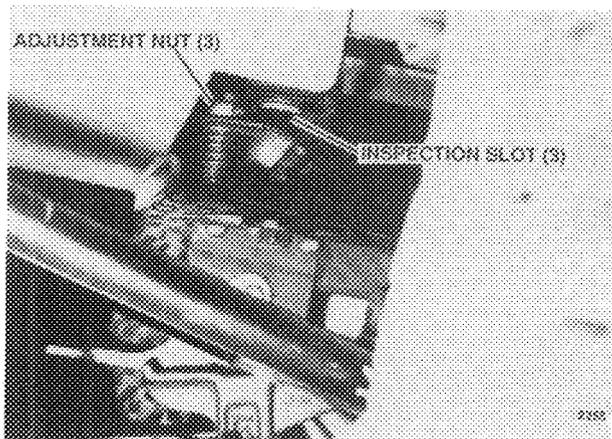

PTO Electric Clutch/Brake Adjustment

PARKING BRAKE ADJUSTMENT

Brake adjustment is made at rear of machine under seat.

1. Loosen rod lock nut.
2. Release transmission push valves.
3. Remove hairpin cotter and pin from clevis. Turn clevis one complete revolution for adjustment and reinstall pin and hairpin cotter. Note proper position of clevis.
4. Repeat step 3 until both rear tires skid when machine is pushed with parking brake set.
5. Tighten brake lock nut while holding adjustment rod. Check so that parking brake can be engaged. If not, brake is too tight.
6. With parking brake released, make sure tractor rolls freely.
7. Engage transmission push valves.

If tractor creeps after brake is released, neutral setting requires adjustment. See your Authorized TORO Wheel Horse Dealer for this adjustment.

CLEANING AND STORAGE

After 30 days, painted surfaces may be waxed to protect lustre of original finish. Machine should

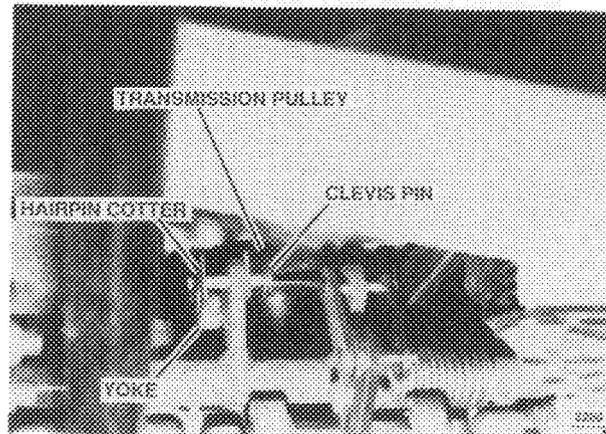

Parking Brake Adjustment

be washed regularly with a mild automotive type detergent and water. Avoid excessive use of water, especially around control panel, engine and transmission. Do not pressure wash.

Exposed bare metal surfaces should be coated with oil for a light coating of grease to prevent rust until permanent repairs can be made. Aerosol cans of touch up paint are available through your Authorized Toro Wheel Horse Dealer.

When machine will not be used for an extended period of time, following steps will help insure minimum difficulty when unit is returned to service:

1. Perform required maintenance steps called for in "Maintenance Checklist".
2. Check tires for proper inflation.
3. Wash machine and repaint all bare metal surfaces.
4. Start machine and engage mower for approximately 1 minute to remove excess water from belts and pulleys. Let engine run out of gas. As gasoline grows old, it becomes less volatile and forms harmful gum and varnish deposits in carburetor and fuel system. **DO NOT STORE GASOLINE FOR MORE THAN 2 MONTHS.**
5. If applicable, charge battery. In temperatures lower than 40°F (4°C) a battery will maintain a charge for about 60 days. In temperatures above 40°F (40°C) water level should be checked and battery "trickle charged" every 30days (more often in higher temperatures). Battery must be fully charged to prevent freezing and internal damage in weather below 32°F (0°C).
6. Remove key from machine.

TROUBLESHOOTING CHECKLIST

SYMPTOM	POSSIBLE CAUSE	POSSIBLE REMEDY
Engine will not turn over/Engine turns over but will not start.	Dead battery. Safety interlock switch. Fuse. Starter or Solenoid. Ignition switch. Spark plug not firing. Ignition system. No fuel in tank. Improper carburetor adjustment.	Charge or replace battery. Be sure mower is disengaged and parking brake is engaged. Replace fuse. Consult authorized dealer. Consult authorized dealer. Check spark plug condition and reset gap. Consult authorized dealer. Fill fuel tank. Reset carburetor adjustment.
Engine hard to start.	Spark plug wire grounded or loose. .. Ignition system. Spark plug faulty or improperly gapped. Fuel line clogged. Carburetor dirty or improperly adjusted.	Check spark plug wires. Consult authorized dealer. Check spark plug condition and reset gap. Clean fuel line. Readjust carburetor. Consult authorized dealer for carburetor service.
Engine starts, but operates erratically.	Clogged fuel line. Water in fuel Vent in fuel cap closed or plugged. .. Improper carburetor adjustment.	Clean fuel line. Drain old fuel and replace with fresh fuel. Check cap vent. Readjust carburetor.
Engine knocks.	Fuel octane too low. Ignition system. Engine overheated.	Drain fuel and replace with higher octane fuel. Consult authorized dealer. Shut off engine and allow to cool. Clean engine air intake screen and fins.
Engine occasionally "skips" at high speed.	Spark plug fouled, faulty or gap too wide. Ignition system. Incorrect carburetor adjustment.	Check spark plug condition and gap. Consult authorized dealer. Readjust carburetor.
Engine overheating.	Air intake screen or fins clogged. Oil level too high or too low. Fuel mixture too lean. Ignition system. Engine overloaded.	Clean air intake screen and fins. Adjust oil level as necessary. Readjust carburetor Consult authorized dealer. Reduce load.
Engine idles poorly.	Improper carburetor adjustment. Improper spark plug gap.	Readjust carburetor Check condition and gap of spark plug.
Engine backfires.	Improper carburetor adjustment. Ignition system.	Readjust carburetor. Consult authorized dealer.
Engine runs fine, but machine will not move.	Faulty transmission. Transmission push valve engaged. ..	Consult authorized dealer. Release push valve.

WIRING DIAGRAM 616-Z,620-Z

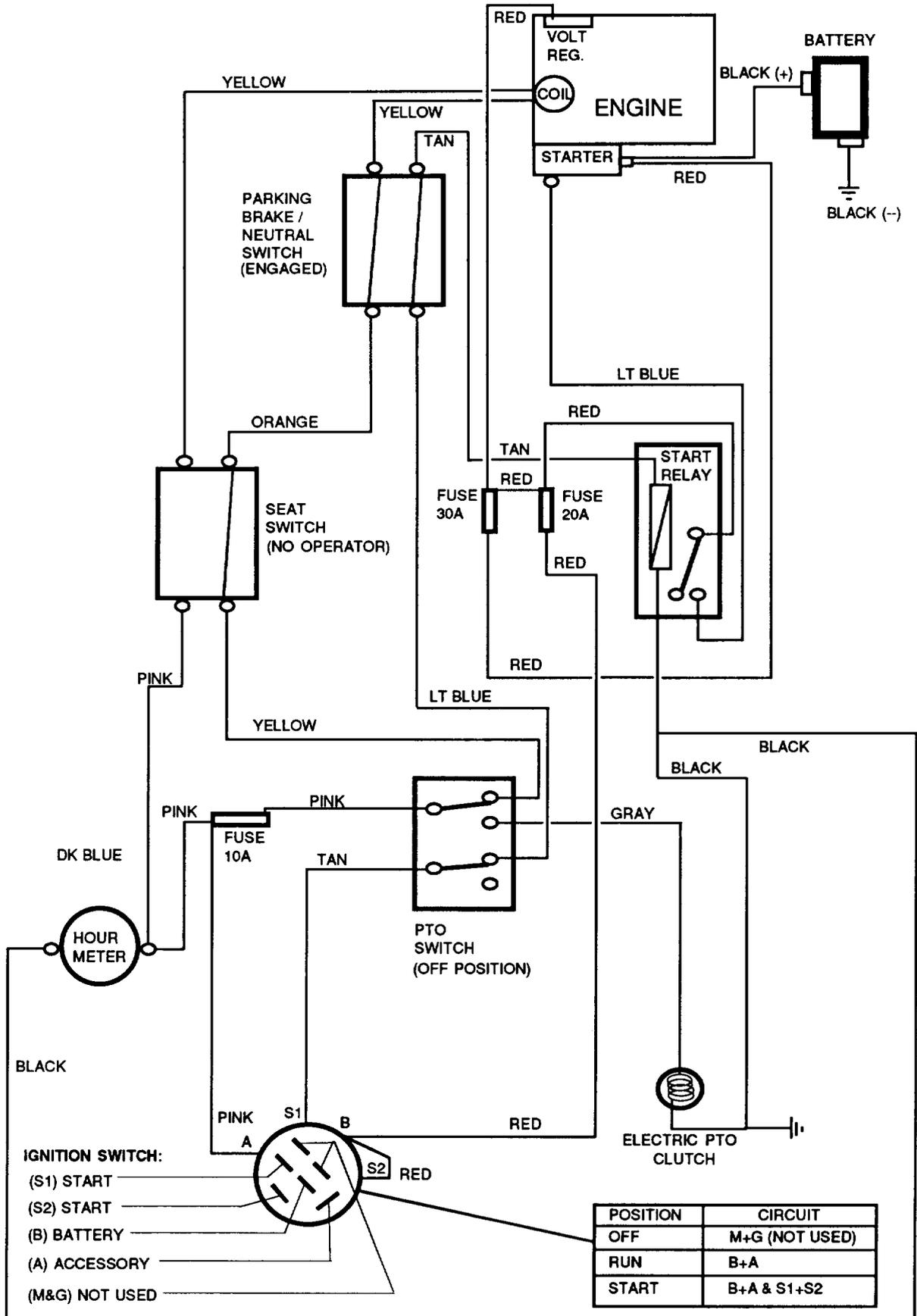

10° SLOPE CHART

ALIGN THIS EDGE WITH A VERTICAL SURFACE
(TREE, BUILDING, FENCEPOST, POLE ETC.)

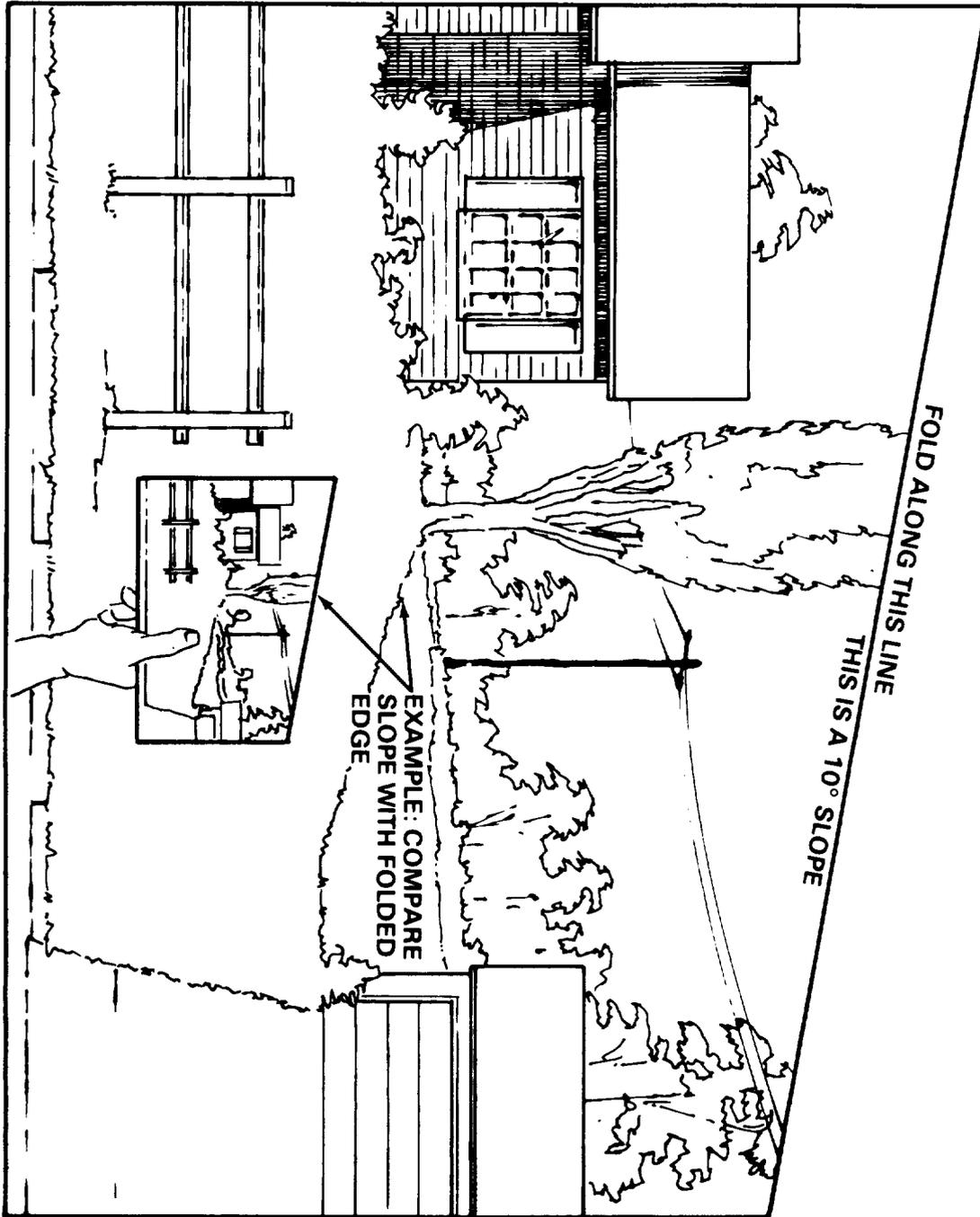



Consumer Products

THE TORO TOTAL COVERAGE GUARANTEE

A Full Two-Year Warranty (Limited Warranty for Commercial Use)

What Is Covered By This Express Warranty?

The Toro Company promises to repair any TORO Product used for residential purposes if defective in materials or workmanship for a period of two years from the date of purchase. The cost of parts and labor are included, but the customer pays the transportation costs.

Transportation within a 15 mile radius of the servicing dealer is covered under this warranty for two-stage snowthrowers, walk behind debris equipment and all TORO Wheel Horse riding products. Walk power mowers, single stage snowthrowers, and other products not specifically covered, are excluded from the transportation coverage provided by this warranty.

What Products Are Covered By This Warranty?

This warranty applies to all gasoline powered Consumer Products (including TORO Wheel Horse riding products). ProLine riding products, wide area walk behind mowers and 21" Commercial mowers without blade stop controls are covered by separate warranty statements.

How About Commercial Use?

TORO Consumer Products used for commercial, institutional or rental use are covered by a limited warranty for the following time periods from the date of purchase:

Products	Warranty Period
• Garden Tractors	
Chassis	1 year limited warranty
Engine	2 year limited warranty
• 21" Commercial Duty Walk Mower with blade stop controls	1 year limited warranty
• Lawn Tractors, Yard Tractors, Rear Engine Riders, 3.0 and 3.5 HP Edgers, Straight Shaft Trimmers, and Backpack Blowers	90 day limited warranty
• All Others	45 day limited warranty

How Do You Get Warranty Service?

Should you feel your TORO product contains a defect in material or workmanship, contact the dealer who sold you the product or any Authorized TORO Service Dealer or TORO Master Service Dealer. The Yellow Pages of your telephone directory is a good reference source. The dealer will either arrange service at his/her dealership or recommend another Authorized Service Dealer who may be more convenient. You may need proof of purchase (copy of registration card, sales receipt, etc.) for warranty validation.

If for any reason you are dissatisfied with the Service Dealer's analysis of the defect in materials or workmanship or if you need a referral to a TORO Service Dealer, please feel free to contact us at the following address:

Toro Customer Service Department
8111 Lyndale Avenue South
Bloomington, MN 55420-1196
612-888-8801

What Must You Do To Keep The Warranty In Effect?

You must maintain your TORO Product by following the maintenance procedures described in the operator's manual. Such routine maintenance, whether performed by a dealer or by you, is at your expense.

What Does This Warranty Not Cover? and

How Does Your State Law Relate To This Warranty?

There is no other express warranty except the TORO Starting Guarantee on GTS Engines. This express warranty does not cover:

- Cost of regular maintenance service or parts, such as filters, fuel, lubricants, tune-up parts, blade sharpening, brake and clutch adjustments.
- Any product or part which has been altered or misused or required replacement or repair due to normal wear, accidents, or lack of proper maintenance.
- Repairs necessary due to improper fuel, contaminants in the fuel system, or failure to properly prepare the fuel system prior to any period of non-use over three months.
- Pickup and delivery charges for distances beyond a 15 mile radius from an Authorized TORO Service Dealer (covered products only).

All repairs covered by this warranty must be performed by an Authorized TORO Service Dealer using Toro approved replacement parts.

Repair by an Authorized TORO Service Dealer is your sole remedy under this warranty.

The Toro Company is not liable for indirect, incidental or consequential damages in connection with the use of the TORO Products covered by this warranty, including any cost or expense of providing substitute equipment or service during reasonable periods of malfunction or non-use pending completion of repairs under this warranty. Some states do not allow exclusions of incidental or consequential damages, so the above exclusion may not apply to you.

This warranty gives you specific legal rights, and you may also have other rights which vary from state to state.

COUNTRIES OTHER THAN THE UNITED STATES OR CANADA

Customers who have purchased TORO products exported from the United States or Canada should contact their TORO Distributor (Dealer) to obtain guarantee policies for your country, province, or state. If for any reason you are dissatisfied with your Distributor's service or have difficulty obtaining guarantee information, contact the TORO importer. If all other remedies fail, you may contact us at The Toro Company.