



Count on it.

Parts Catalog

**Z Master® Commercial 2000
Series Riding Mower**

**with 48IN TURBO FORCE® Side Discharge
Mower**

Model No. 74142TE—Serial No. 315000001 and Up



Ordering Replacement Parts

To order replacement parts, please supply the part number, the quantity, and the description of each part desired.

Understanding Reference Numbers

Each identified part in an illustration has a reference number. The reference number for a part also appears in the parts list, along with other information about the part.

This catalog uses two special reference number formats, one to indicate parts in a service assembly and another to indicate the quantity of a given part in an illustration.

Service Assembly Reference Numbers

Parts in service assemblies have reference numbers in the form a:b. The a represents the reference number of the entire service assembly and the b represents a sequential number unique to each part within the service assembly.

For example, a wheel assembly might be identified by reference number 6, the tire by 6:1, the valve by 6:2, and the wheel by 6:3. When you order the assembly identified by reference number 6, you receive all parts identified by reference numbers 6:1, 6:2, and 6:3. However, you may also order any part individually. Reference numbers of this type appear in illustration and in parts lists.

Reference Numbers Indicating Quantity

In an illustration, if a reference number indicates more than one part, the reference number has the form nX y. The n represents the quantity of the part, the X is the multiplication symbol, and the y represents the reference number.

For example, in an illustration, the reference number 2X 37 means that two of the parts identified by reference number 37 are indicated.

List of Abbreviations

AR: as required

ASM: assembly

BBC: blade brake control

BHTF: button head thread forming

CARR: carriage

CCW: counter clockwise

CW: clockwise

DEG: degrees

DPA: Dual Point Adjustment

ECM: electronic control module

EXT: external

FH: flat head

GA: gauge

HD: heavy-duty

HF: hex flange

HH: hex head

HHF: hex head flange

HHFTF: hex head flange thread forming

HJ: hex jam

HLH: hex lag head

HOC: height-of-cut

HP: high pressure

HSBH: hex socket button head

HSFH: hex socket flat head

HSH: hex socket head

HWH: hex washer head

HWHTF: hex washer head thread forming

HYD: hydraulic

LH: left hand

LP: low pressure

LPG: Liquefied Petroleum Gas

NI: nylon insert

NPTF: national pipe thread fine

PFH: phillips flat head

PPH: phillips pan head

PPHTF: phillips pan head thread forming

PRH: phillips round head

PTH: phillips truss head

PTO: power-take-off

RH: right hand

ROPS: roll-over protection system

RRB: rear roller brush

SFH: slotted fillister head

SHH: slotted hex head

SHWH: slotted hex washer head

SPH: slotted pan head

SQH: square head

SRH: slotted round head

STD: standard

TAP: self tapping

TTH: torx truss head

Contents

Frame and Caster Wheel Assembly	4
Roll-Over Protection System Assembly No. 116-0231	6
Caster Fork and Wheel Assembly	8
Z Stand and Weight Assembly	10
Z Stand Assembly	12
Hydro Drive System Assembly	14
Hydro Idler Arm Assembly	16
RH Transaxle Assembly No. 130-2850	18
LH Transaxle Assembly No. 130-2851	20
Fuel Tank and Hose Assembly	22
Seat Mounting Assembly	24
Seat Assembly No. 127-9538	26
Motion Control Assembly	28
Parking Brake Assembly	30
Engine, Muffler and Control Panel Assembly	32
Deck Lift Assembly	34
Height-of-Cut Assembly No. 121-4779	36
Deck Assembly	38
Deck Decal Assembly No. 131-7664	40
Deflector Assembly No. 120-2451	42
Idler Assembly	44
Electrical Assembly	46
Attachments and Accessories	48

Frame and Caster Wheel Assembly

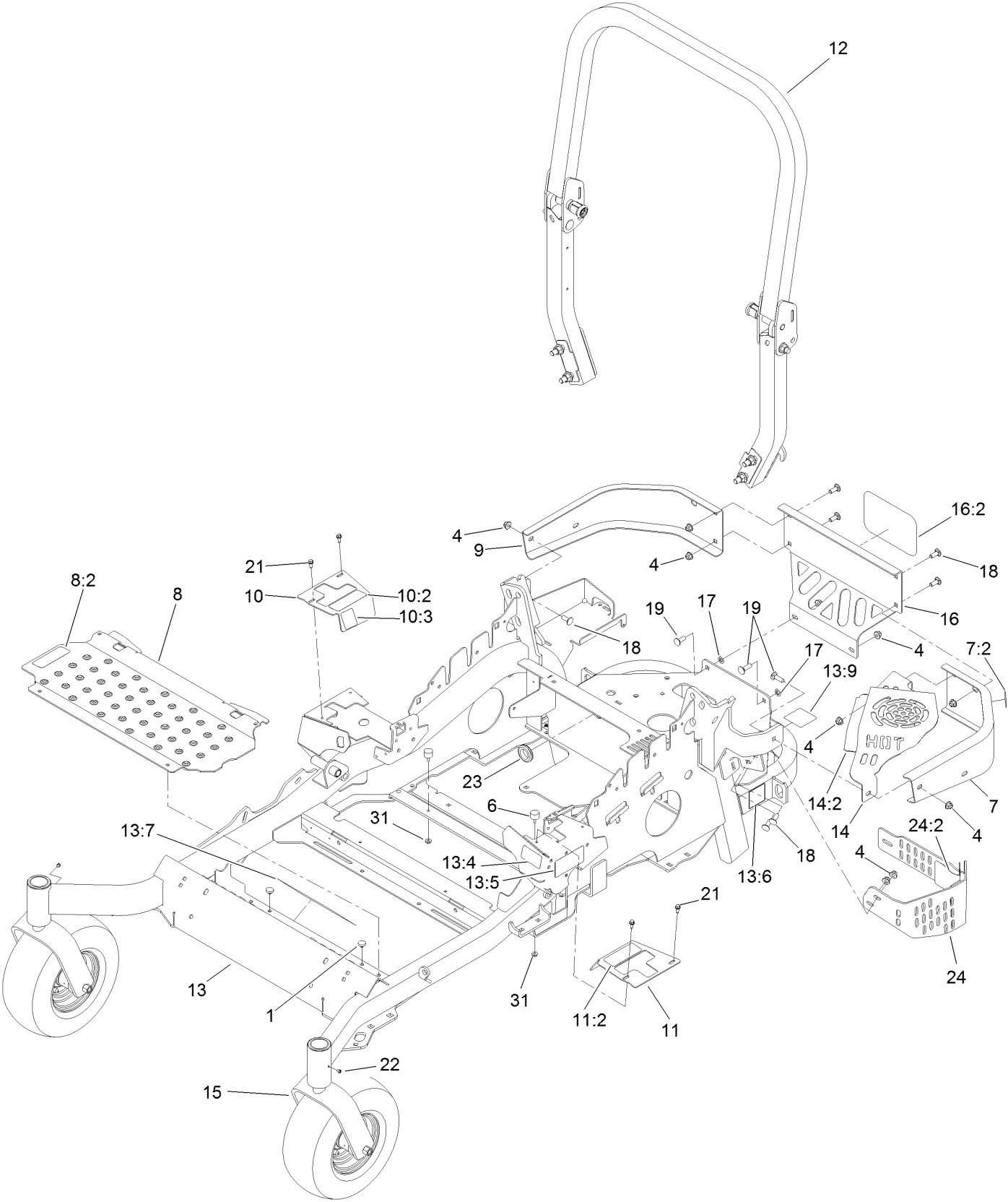

Frame and Caster Wheel Assembly (continued)

<i>Ref.</i>	<i>Part Number</i>	<i>Qty.</i>	<i>Description</i>	<i>Ref.</i>	<i>Part Number</i>	<i>Qty.</i>	<i>Description</i>
1	1-513658	2	Bumper	13:7	127-0335	1	Decal-Warning, Slope
4	104-8301	12	Nut-Flange, NI	13:9	117-1158	2	Decal-Bypass
6	116-6380	2	Bumper-Rubber (W/ Stud)	14	121-4800	1	Muffler Guard ASM W/Foil
7	109-9869	1	Bumper-Rear, LH	14:2	121-4792	1	Foil-Tape
7:2	106-5517	1	Decal-Warning, Hot Surface	15		2	Front Caster ASM ●
8	117-0915	1	Floorpan ASM	16	119-2691	1	Rear Guard ASM
8:2	112-9028	1	Decal-Cover Missing	16:2	67-7320	1	Decal
9	116-0508-03	1	Bumper-Rear, RH	17	107-3154	2	Nut-Push
10	121-4780	1	RH Motion Control Cover ASM	18	3231-22	7	Screw-CARR
10:2	99-8936	1	Decal-Control, Motion	19	3231-25	3	Bolt-CARR
10:3	116-5988	1	Decal-Park Brake, Ce	21	32144-10	4	Screw-HWH
11	121-4789	1	Motion Control Cover ASM	22	1-811010	2	Plug
11:2	99-8936	1	Decal-Control, Motion	23	120-3265	1	Grommet
12	116-0231	1	ROPS ASM	24	121-4781	1	LH Lower Muffler Guard ASM
13	131-7660	1	Frame ASM	24:2	106-5517	1	Decal-Warning, Hot Surface
13:4	117-3864	1	Decal-Fuel Fill, Ce	31	104-7201	2	Nut-HF
13:5	120-5891	2	Decal				
13:6	106-2655	2	Decal-Hazard, Pinched Finger				

● Not serviced separately

Roll-Over Protection System Assembly No. 116-0231

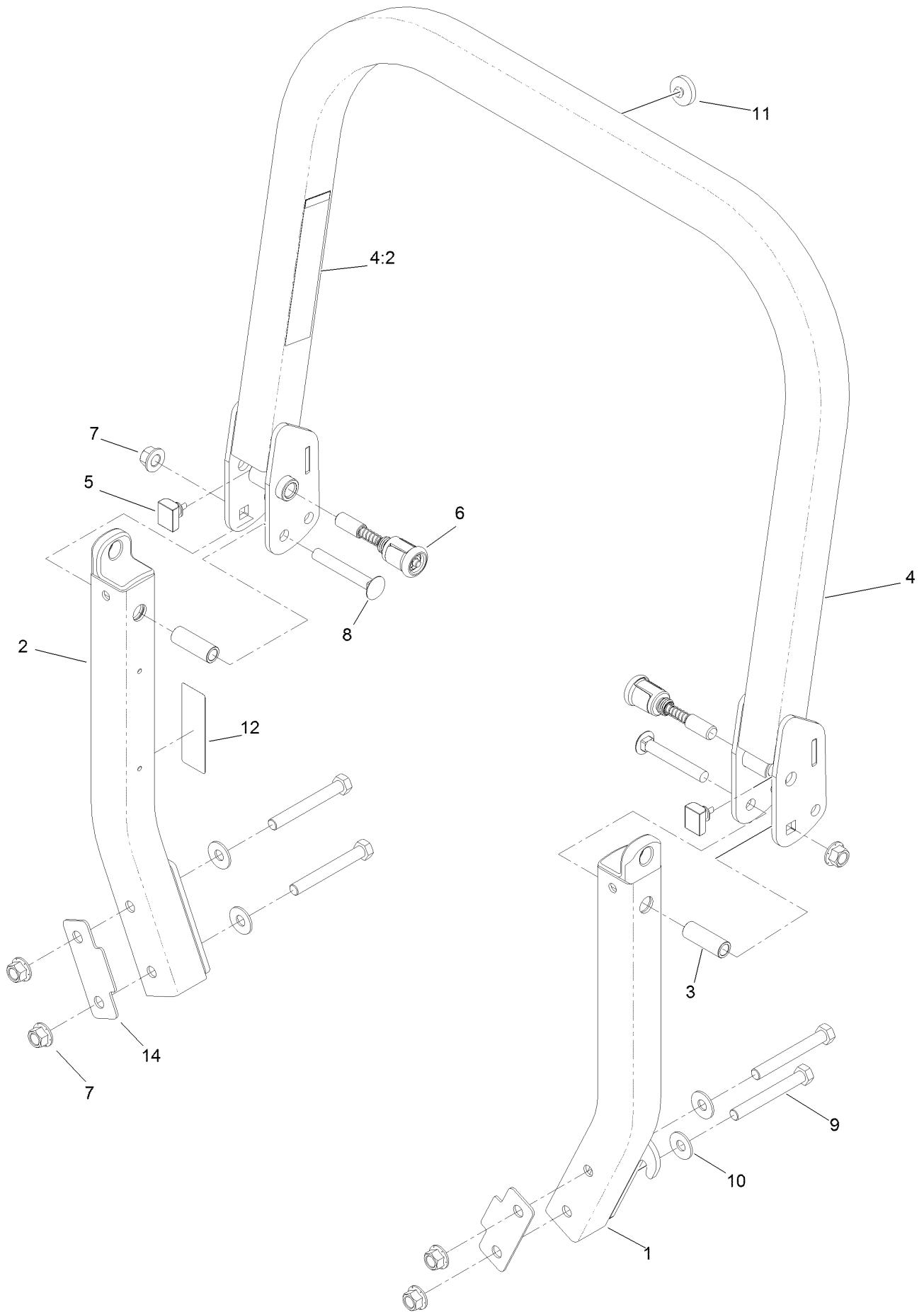

Roll-Over Protection System Assembly No. 116-0231 (continued)

<i>Ref.</i>	<i>Part Number</i>	<i>Qty.</i>	<i>Description</i>	<i>Ref.</i>	<i>Part Number</i>	<i>Qty.</i>	<i>Description</i>
1		1	Leg-ROPS, LH ●	7	99-5107	6	Nut-Lock
2		1	Leg-ROPS, RH ●	8	3233-10	2	Screw-CARR
3	109-6653	2	Spacer	9	325-35	4	Screw-HH
4		1	Upper ROPS ASM ●	10	109-9505	4	Washer-Spring
4:2	107-3069	1	Decal-Warning, Folding ROPS	11	109-9233	1	Bumper-Push-In, Rubber
5	109-5337	2	Bumper-ROPS	12	117-0346	1	Decal-Caution, Fuel Vent
6	116-0104	2	Pin-Spring	14	116-0960	2	Spacer

● Not serviced separately

Caster Fork and Wheel Assembly

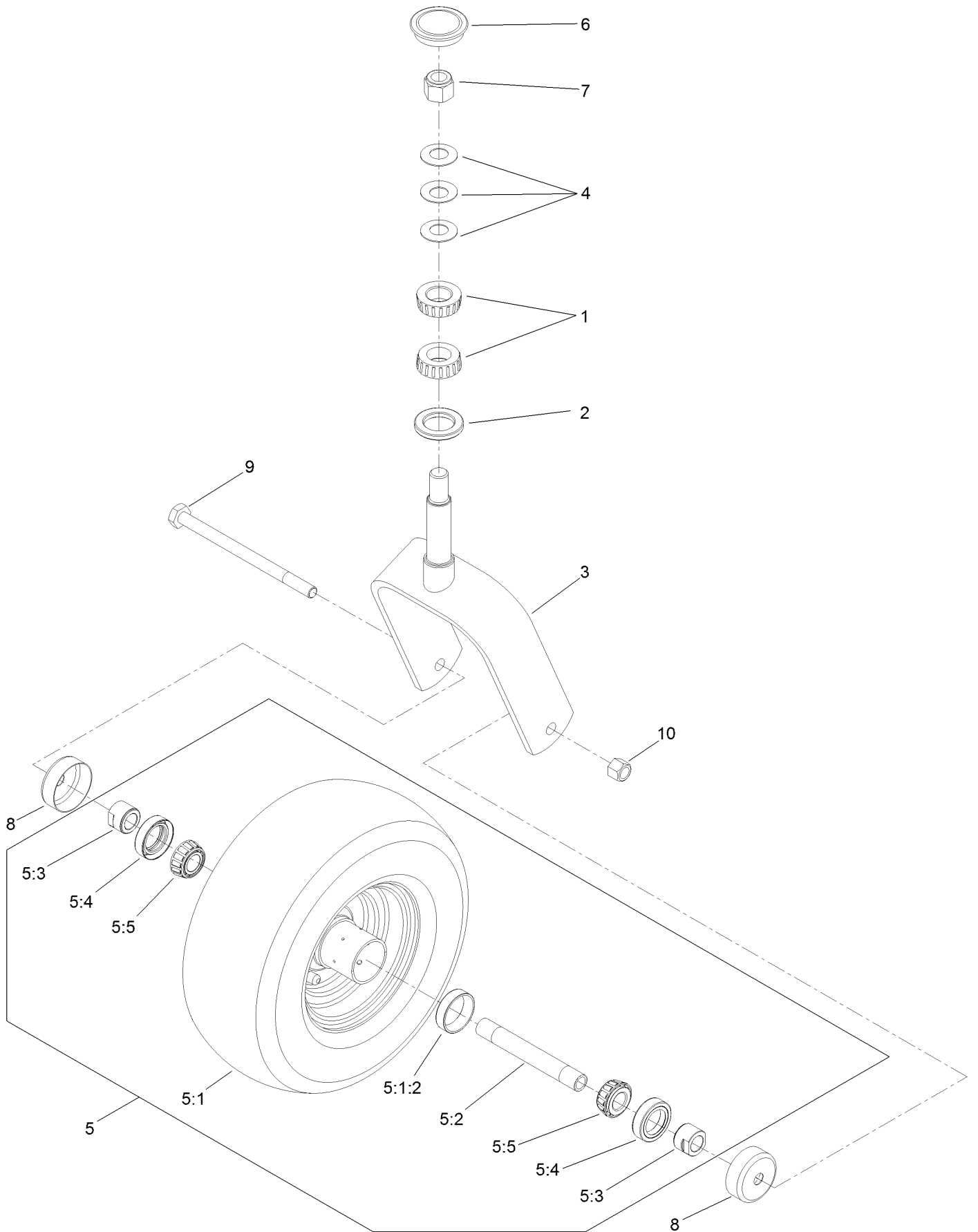

Caster Fork and Wheel Assembly (continued)

<i>Ref.</i>	<i>Part Number</i>	<i>Qty.</i>	<i>Description</i>	<i>Ref.</i>	<i>Part Number</i>	<i>Qty.</i>	<i>Description</i>
1	1-543509	2	Bearing-Roller, Tapered	5:3	103-3051	2	Spacer-Nut
2	116-5647	1	Seal-Grease	5:4	103-0063	2	Seal-Caster
3	116-6701-01	1	Fork-Caster	5:5	1-633585	2	Bearing-Cone, Taper
4	1-633508	3	Washer-Bellville	6	103-4882	1	Cap-Grease
5	103-5362	1	Wheel And Bearing ASM	7	3296-51	1	Nut-Lock, NI
5:1		1	Wheel And Tire ASM ●	8	103-2768	2	Guard-Seal
5:1:2	1-633584	2	Bearing-Cup	9	325-36	1	Screw-HH
5:2	103-3155	1	Axle-Caster	10	3296-23	1	Nut-Lock, NI

● Not serviced separately

Z Stand and Weight Assembly

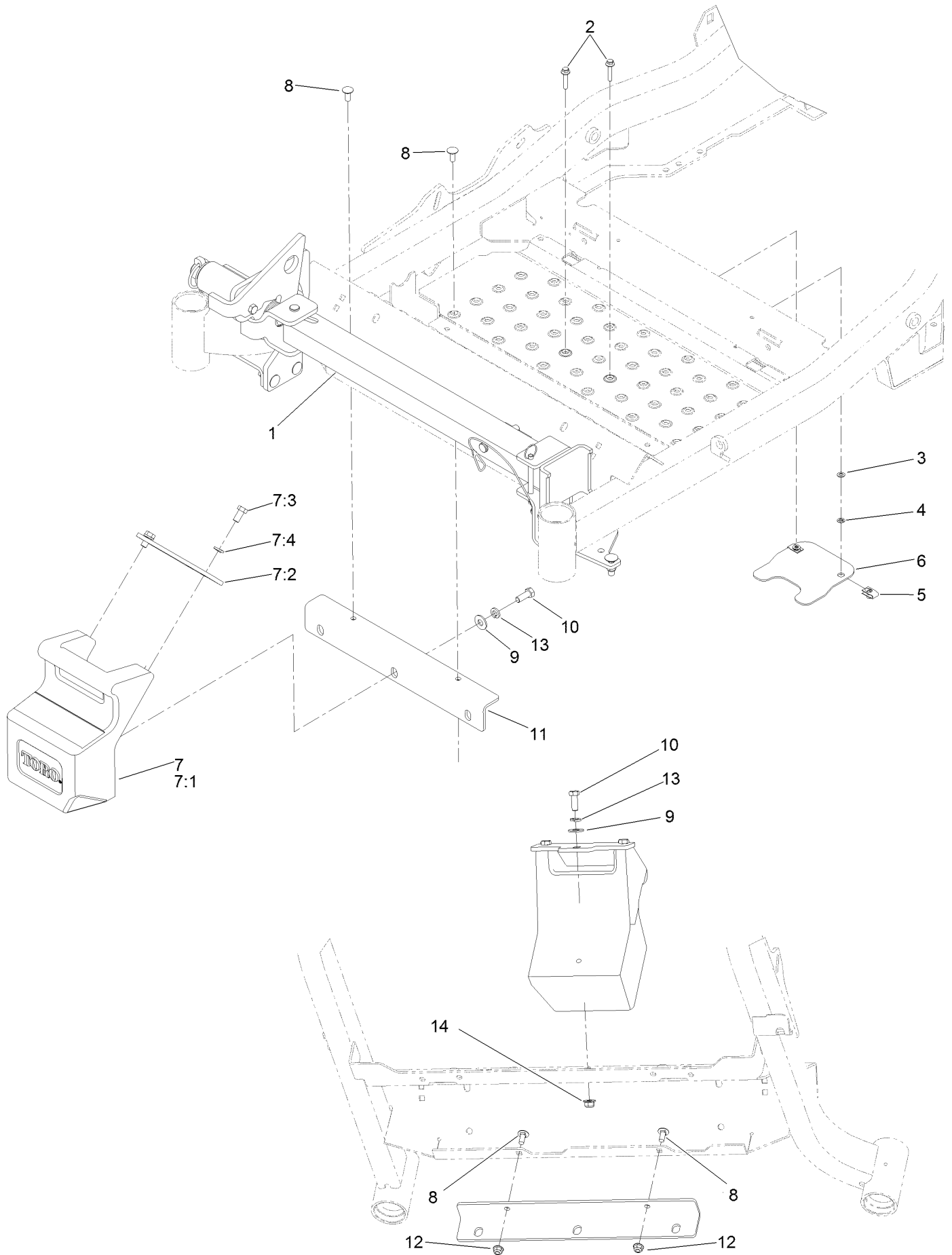

Z Stand and Weight Assembly (continued)

<i>Ref.</i>	<i>Part Number</i>	<i>Qty.</i>	<i>Description</i>	<i>Ref.</i>	<i>Part Number</i>	<i>Qty.</i>	<i>Description</i>
1		1	Z Stand ASM ●	7:3	323-4	2	Screw-HH
2	3234-21	2	Screw-HHF	7:4	3253-5	2	Washer-Lock
3	3256-60	2	Washer-Flat	8	3230-23	2	Screw-CARR
4	106-8737	2	Nut-Retainer	9	3256-4	2	Washer-Flat
5	107069	2	Clip	10	323-6	2	Screw-HH
6	119-0395-03	1	Adapter-Captive	11	115-3615-01	1	Bracket-Mount, Weight
7	120-7885	1	Weight ASM	12	104-8300	2	Nut-Flange, NI
7:1	120-7881	1	Weight-43 Lb	13	3253-5	2	Washer-Lock
7:2	115-3616-01	1	Tab-Support, Weight	14	104-8301	1	Nut-Flange, NI

● Not serviced separately

Z Stand Assembly

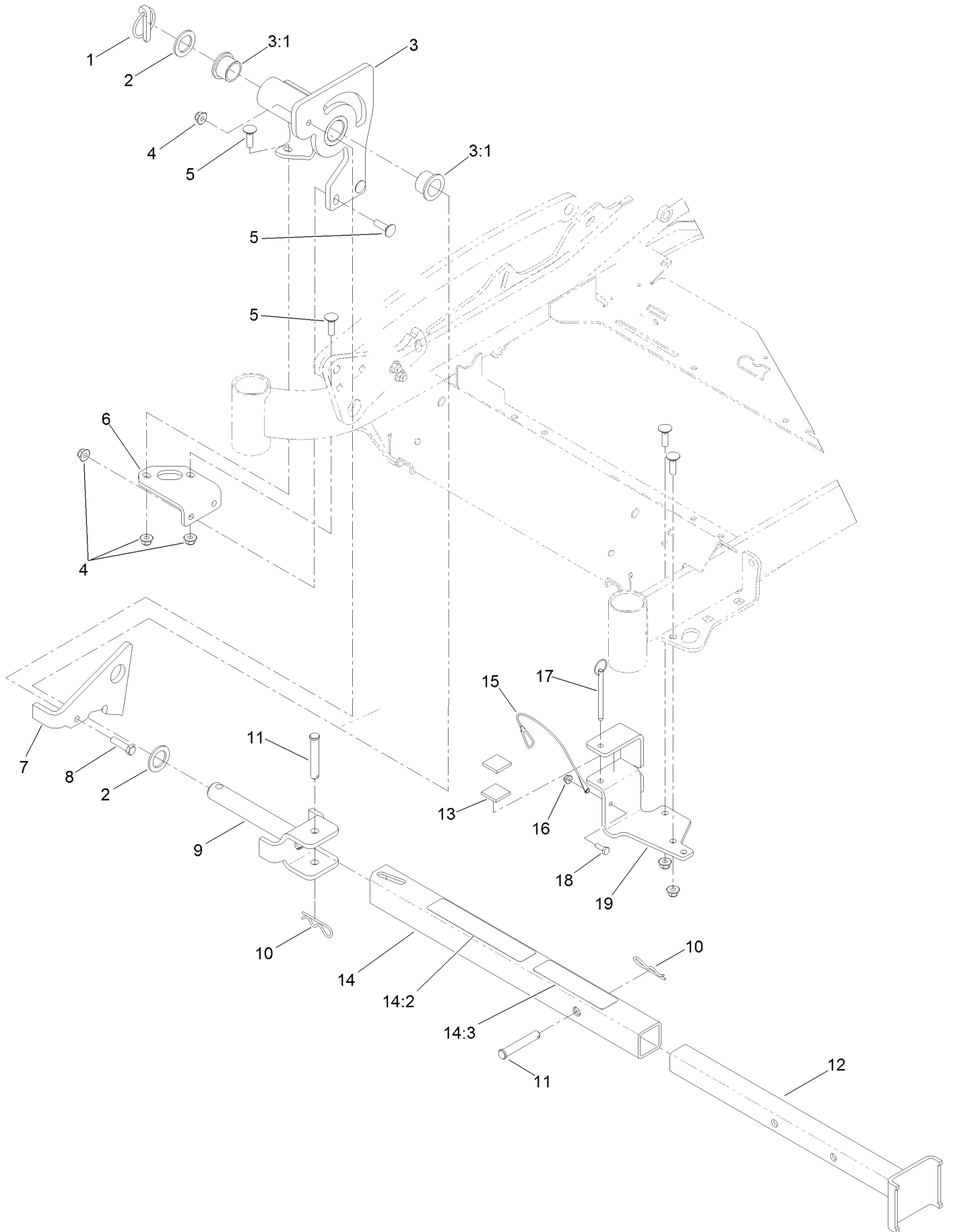

Z Stand Assembly (continued)

<i>Ref.</i>	<i>Part Number</i>	<i>Qty.</i>	<i>Description</i>	<i>Ref.</i>	<i>Part Number</i>	<i>Qty.</i>	<i>Description</i>
1	283-71	1	Pin-Lynch	11	283-55	2	Pin-Clevis
2	3-6781	2	Washer-Thrust	12	115-3631-01	1	Tube-Inner
3	115-3635	1	Z Stand Pivot ASM	13	115-3613	2	Cushion-Rubber
3:1	94-1291	2	Bushing	14	115-3634	1	Outer Tube ASM
4	104-8301	8	Nut-Flange, NI	14:2	106-7464	1	Decal-Z Stand
5	3231-25	7	Bolt-CARR	14:3	107-3969	1	Decal-Warning
6	115-3619-01	1	Bracket-Mount, Pivot	15	100-9385	1	Lanyard-Nylon
7	100-9686-01	1	Bracket-Latch	16	104-7201	1	Nut-HF
8	323-8	1	Screw-HH	17	105-1647	1	Pin-Hitch, Cotterless
9	100-9692-01	1	Pin-Pivot	18	321-4	1	Screw-HH
10	3290-355	2	Pin-Hair	19	115-3625-01	1	Cradle-Z Stand

Hydro Drive System Assembly

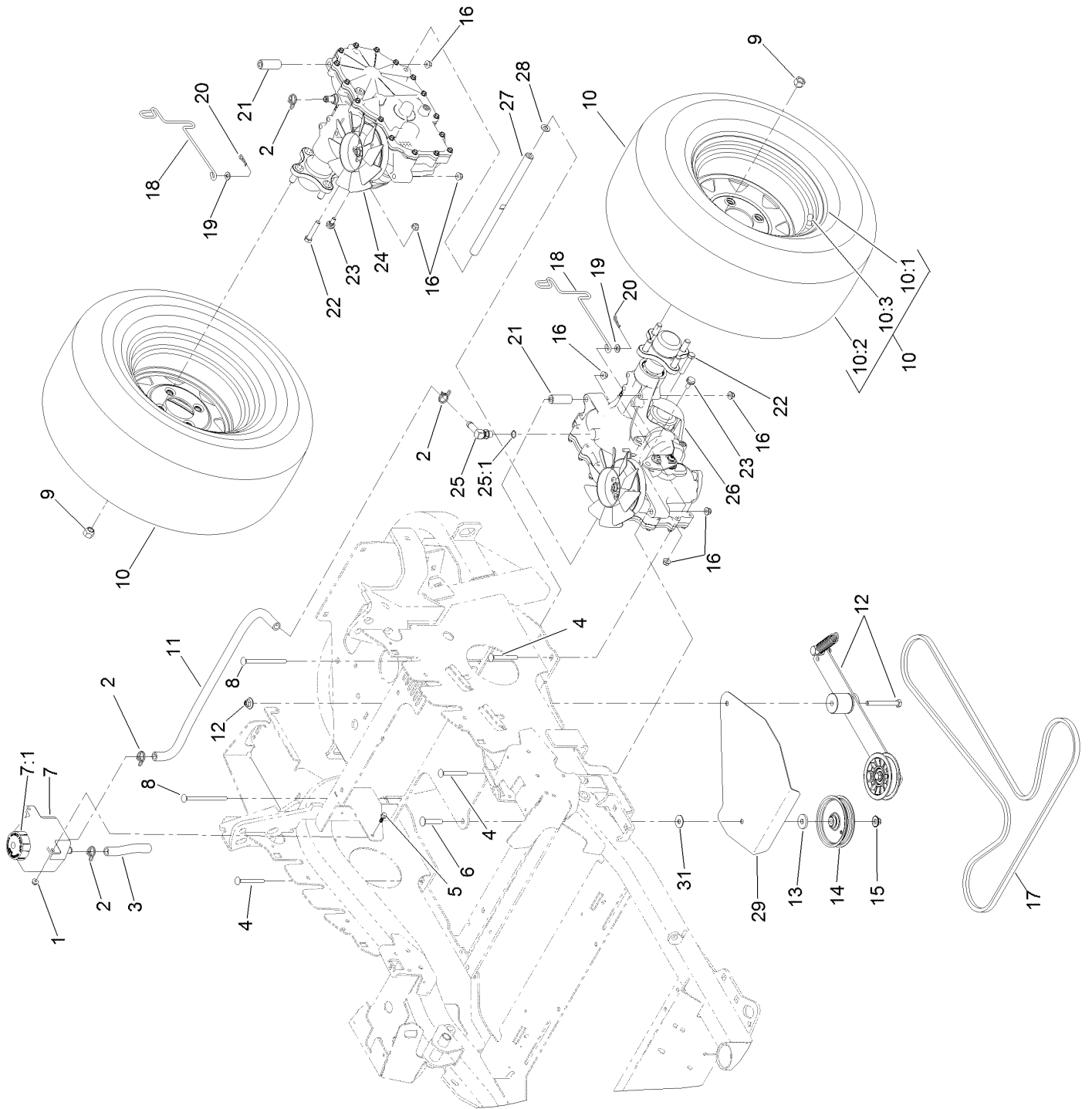

Hydro Drive System Assembly (continued)

<i>Ref.</i>	<i>Part Number</i>	<i>Qty.</i>	<i>Description</i>	<i>Ref.</i>	<i>Part Number</i>	<i>Qty.</i>	<i>Description</i>
1	104-7201	2	Nut-HF	15	109-6658	1	Nut-Flange, NI
2	117-1193	4	Clamp-Hose	16	104-8300	10	Nut-Flange, NI
3	119-2642	1	Hose-HYD	17	114860	1	Belt-V
4	3230-9	6	Screw-CARR	18	125-8950	2	Rod-Bypass
5	99-6810	2	Screw-HHF	19	3256-23	2	Washer-Flat
6	117-9971	1	Bolt-Carriage	20	1-806003	2	Pin-Cotter
7	109-2250	1	Vent-Tank, Hydro	21	109-3652	2	Spacer-Hydro
7:1	109-3320	1	Cap-Reservoir, HYD	22	94-7972	2	Screw-HH W/Loctite
8	3230-30	2	Screw-CARR	23	37-8771	2	Bolt-Shoulder
9	242-50	8	Nut-Lug	24	130-2850	1	RH Transaxle ASM
10	119-2692	2	Wheel And Tire ASM	25	109-6449	1	Fitting-Elbow, 90
10:1	120-3274	1	Wheel	25:1	237-42	1	O-Ring
10:2	120-3271	1	Tire	26	130-2851	1	LH Transaxle ASM
10:3	232-27	1	Stem-Valve	27	117-8585	1	Shaft-Cross, Hydro
11	119-2689	1	Hose-HYD	28	3256-24	1	Washer-Flat
12		1	Hydro Idler Arm ASM ●	29	125-4777-01	1	Plate-Guard
13	1-373034	1	Washer	31	52-2860	1	Washer
14	93-1622	1	Pulley-Idler				

● Not serviced separately

Hydro Idler Arm Assembly

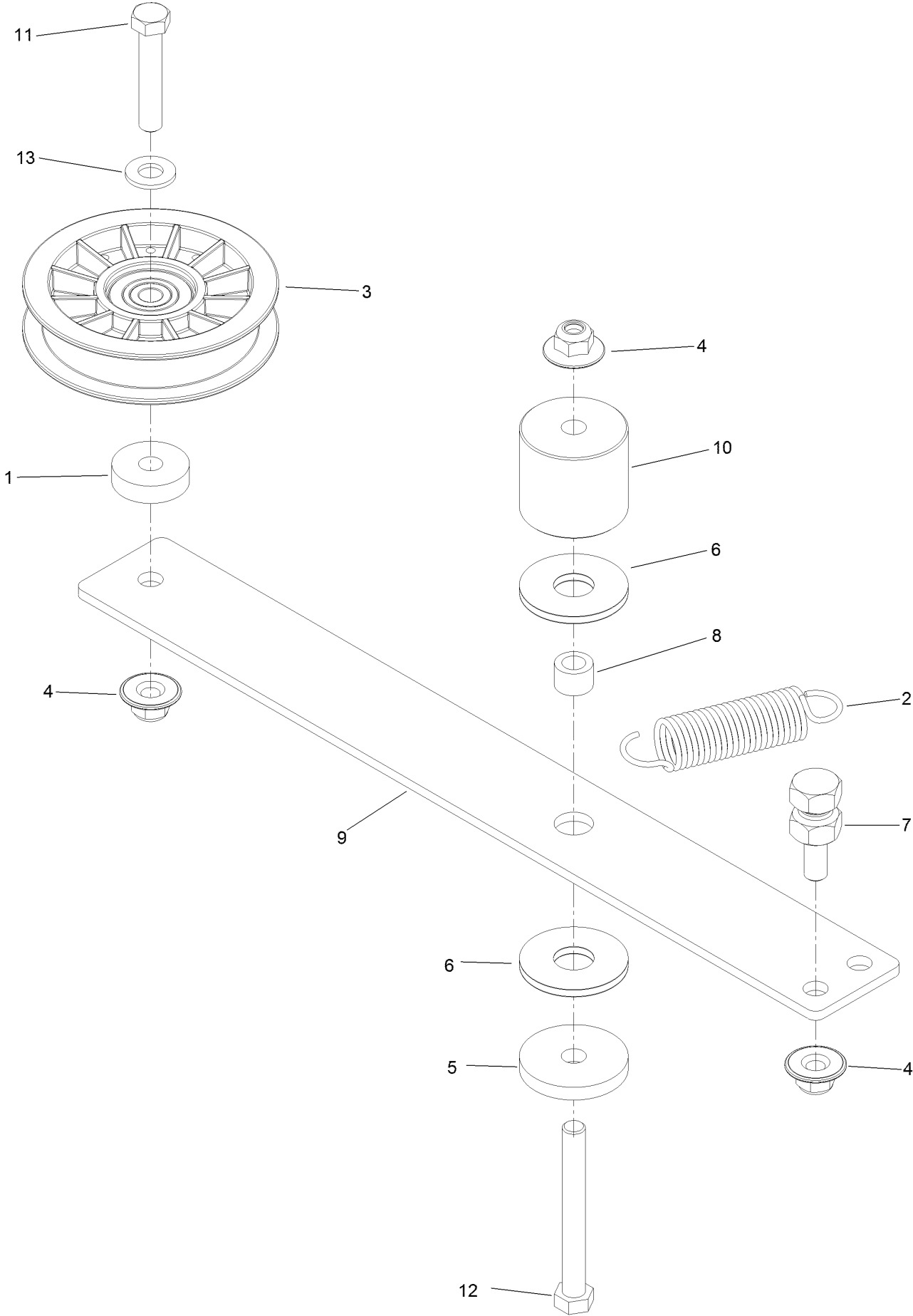

Hydro Idler Arm Assembly (continued)

<i>Ref.</i>	<i>Part Number</i>	<i>Qty.</i>	<i>Description</i>	<i>Ref.</i>	<i>Part Number</i>	<i>Qty.</i>	<i>Description</i>
1	105-7788	1	Spacer	8	115-4986	1	Spacer
2	108-4056	1	Spring-Extension	9	119-9914	1	Arm-Idler, Hydro
3	109-3397	1	Pulley-Idler, Flat	10	119-2657	1	Spacer-Plain
4	109-6658	3	Nut-Flange, NI	11	323-10	1	Screw-HH
5	110-9981	1	Washer-Plain	12	323-20	1	Screw-HH
6	114-0463	2	Washer-Friction, Composite	13	3256-24	1	Washer-Flat
7	114-5866	1	Anchor-Spring, Short				

RH Transaxle Assembly No. 130-2850

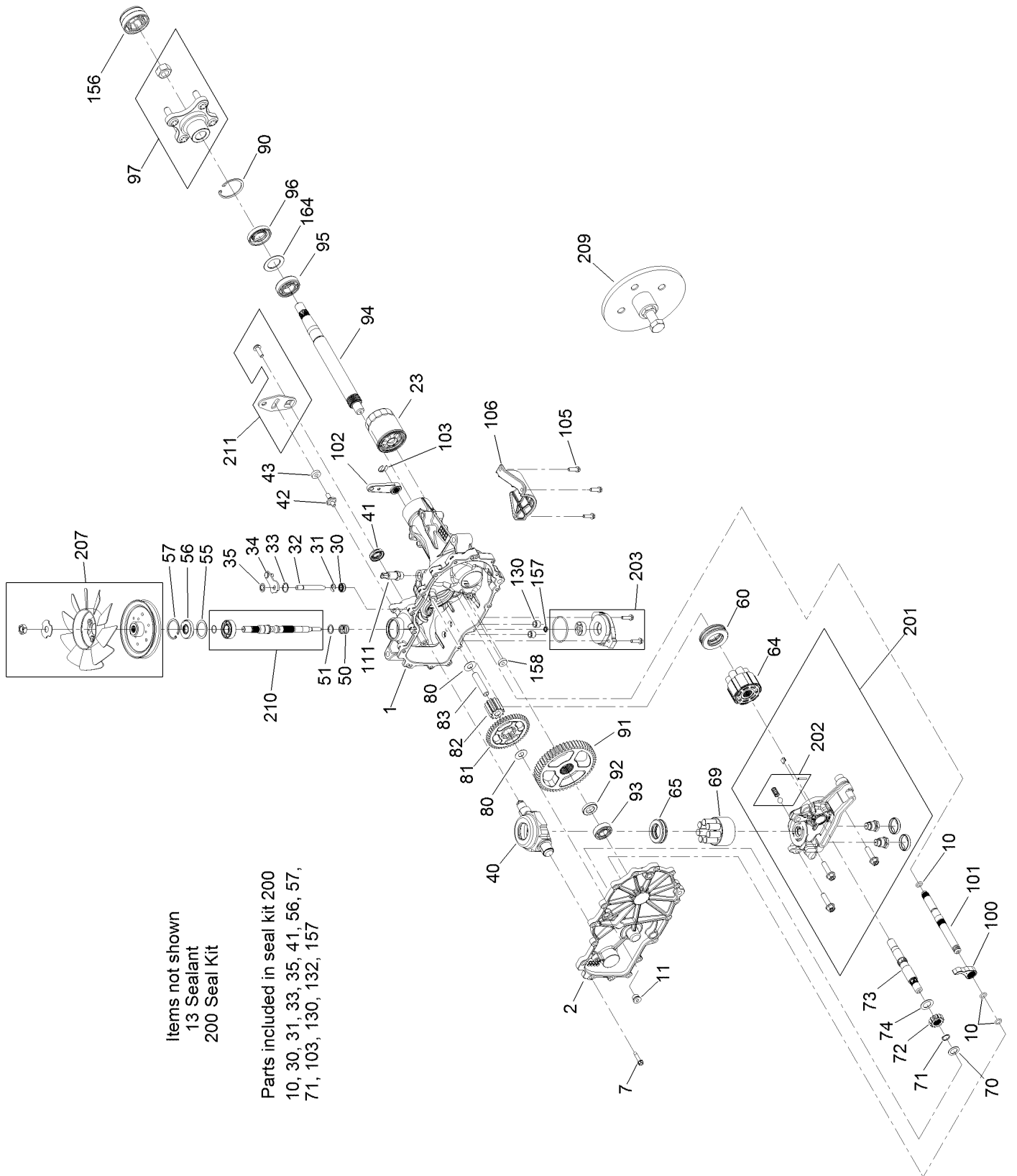

Items not shown
 13 Sealant
 200 Seal Kit

Parts included in seal kit 200
 10, 30, 31, 33, 35, 41, 56, 57,
 71, 103, 130, 132, 157

RH Transaxle Assembly No. 130-2850 (continued)

<i>Ref.</i>	<i>Part Number</i>	<i>Qty.</i>	<i>Description</i>	<i>Ref.</i>	<i>Part Number</i>	<i>Qty.</i>	<i>Description</i>
1	121-3231	1	RH Main Housing Kit	80	94-1933	2	Washer
2	121-3232	1	RH Side Cover Kit	81	120-7973	1	Gear-46T
7	117-5359	16	Screw-HHF	82	120-7974	1	Gear-11T
10	130-8483	4	O-Ring	83	104-5329	1	Pin-Jackshaft
11	104-2189	1	Plug-Thread, Straight	90	104-2169	1	Ring-Retaining
13	104-2147	1	Sealant ●	91	121-3237	1	Gear-54T
23	109-3321	1	Element-Oil Filter, HYD	92	120-7975	1	Spacer
30	106-8676	1	Seal-Lip	93	130-8476	1	Bearing-Ball
31	106-8677	1	Ring-Retaining, EXT	94	121-3238	1	Shaft-Axle
32	114-1685	1	Rod-Bypass	95	130-8477	1	Bearing-Ball
33	106-8679	1	Ring-Retaining, Int	96	130-8478	1	Seal-Lip
34	107-2490	1	Arm-Bypass	97	109-5939	1	Hub Kit
35	106-8681	1	Ring-Retaining, EXT	100	114-1697	1	Pawl-Brake
40	104-5304	1	Swashplate-Trunnion	101	130-8479	1	Shaft-Brake
41	104-5313	1	Seal-Lip	102	125-0021	1	Handle-Brake
42	104-2116	1	Stud	103	130-8484	1	Ring-Retaining, EXT
43	112-9853	1	Puck-Friction	105	104-2120	3	Screw
50	120-5537	1	Spring-Compression	106	120-7981	1	Guard-Filter, RH
51	120-5538	1	Washer	111	109-3278	1	Adapter-Straight
55	104-5308	1	Spacer	130	130-8485	2	Tube-Push, O-Ring
56	104-5310	1	Seal-Lip	156	115-5057	1	Cover-Nut, Axle
57	104-5309	1	Ring-Retaining	157	130-8486	1	Seal-Gerotor
60	109-2865	1	Bearing-Thrust	158	104-5330	1	Magnet-Ring
64	114-1689	1	Motor Cylinder Block Kit	164	130-8480	1	Spacer
65	121-3235	1	Bearing-Thrust, Plastic Cage	200	121-3243	1	Seal Kit
69	121-3236	1	7 Piston Block ASM	201	130-8481	1	Center Section Kit
70	104-5339	1	Washer-Flat	202	114-8464	1	Charge Relief Kit
71	104-5340	1	Ring-Retaining	203	121-3246	1	Charge Pump Kit
72	120-7972	1	Gear-13T	207	121-3247	1	Fan And Pulley Kit
73	114-1691	1	Shaft-Motor	209	130-8482	1	Hub Puller Kit
74	104-5360	1	Washer	210	121-3248	1	Input Shaft Kit
				211	117-5362	1	Arm Control Kit

● Not illustrated

LH Transaxle Assembly No. 130-2851

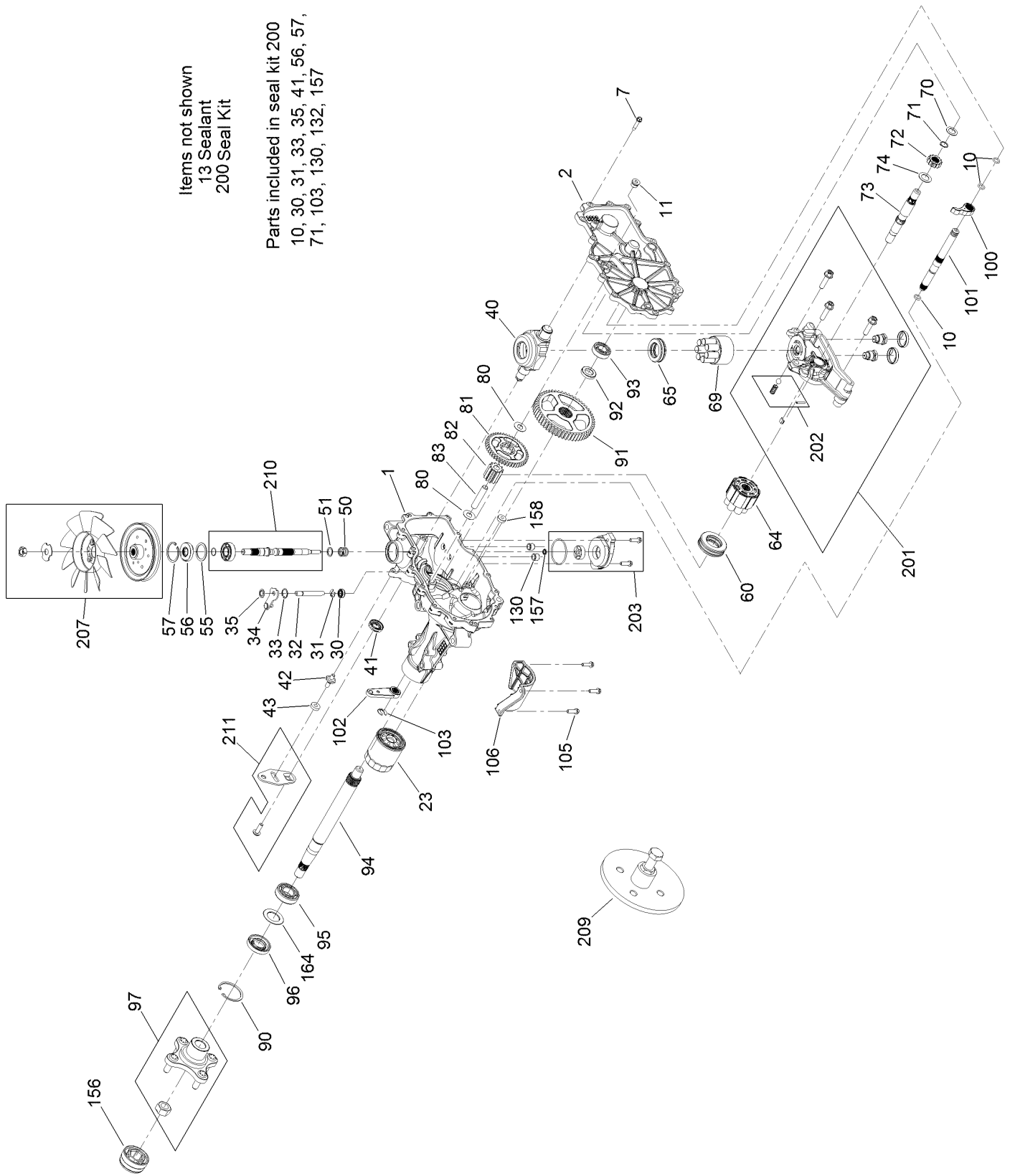

Items not shown
 13 Sealant
 200 Seal Kit

Parts included in seal kit 200
 10, 30, 31, 33, 35, 41, 56, 57,
 71, 103, 130, 132, 157

LH Transaxle Assembly No. 130-2851 (continued)

<i>Ref.</i>	<i>Part Number</i>	<i>Qty.</i>	<i>Description</i>	<i>Ref.</i>	<i>Part Number</i>	<i>Qty.</i>	<i>Description</i>
1	121-3233	1	LH Main Housing Kit	80	94-1933	2	Washer
2	121-3234	1	LH Side Cover Kit	81	120-7973	1	Gear-46T
7	117-5359	16	Screw-HHF	82	120-7974	1	Gear-11T
10	130-8483	4	O-Ring	83	104-5329	1	Pin-Jackshaft
11	104-2189	1	Plug-Thread, Straight	90	104-2169	1	Ring-Retaining
13	104-2147	1	Sealant ●	91	121-3237	1	Gear-54T
23	109-3321	1	Element-Oil Filter, HYD	92	120-7975	1	Spacer
30	106-8676	1	Seal-Lip	93	130-8476	1	Bearing-Ball
31	106-8677	1	Ring-Retaining, EXT	94	121-3238	1	Shaft-Axle
32	114-1685	1	Rod-Bypass	95	130-8477	1	Bearing-Ball
33	106-8679	1	Ring-Retaining, Int	96	130-8478	1	Seal-Lip
34	107-2490	1	Arm-Bypass	97	109-5939	1	Hub Kit
35	106-8681	1	Ring-Retaining, EXT	100	114-1697	1	Pawl-Brake
40	104-5304	1	Swashplate-Trunnion	101	114-1698	1	Shaft-Brake, Inboard
41	104-5313	1	Seal-Lip	102	125-0021	1	Handle-Brake
42	104-2116	1	Stud	103	130-8484	1	Ring-Retaining, EXT
43	112-9853	1	Puck-Friction	105	104-2120	3	Screw
50	120-5537	1	Spring-Compression	106	120-7979	1	Guard-Filter, LH
51	120-5538	1	Washer	130	130-8485	2	Tube-Push, O-Ring
55	104-5308	1	Spacer	156	115-5057	1	Cover-Nut, Axle
56	104-5310	1	Seal-Lip	157	130-8486	1	Seal-Gerotor
57	104-5309	1	Ring-Retaining	158	104-5330	1	Magnet-Ring
60	109-2865	1	Bearing-Thrust	164	130-8480	1	Spacer
64	114-1689	1	Motor Cylinder Block Kit	200	121-3243	1	Seal Kit
65	121-3235	1	Bearing-Thrust, Plastic Cage	201	130-8487	1	Kit-Center Section (LH Charge)
69	121-3236	1	7 Piston Block ASM	202	114-8464	1	Charge Relief Kit
70	104-5339	1	Washer-Flat	203	121-3246	1	Charge Pump Kit
71	104-5340	1	Ring-Retaining	207	121-3247	1	Fan And Pulley Kit
72	120-7972	1	Gear-13T	209	130-8482	1	Hub Puller Kit
73	114-1691	1	Shaft-Motor	210	121-3248	1	Input Shaft Kit
74	104-5360	1	Washer	211	117-5362	1	Arm Control Kit

● Not illustrated

Fuel Tank and Hose Assembly

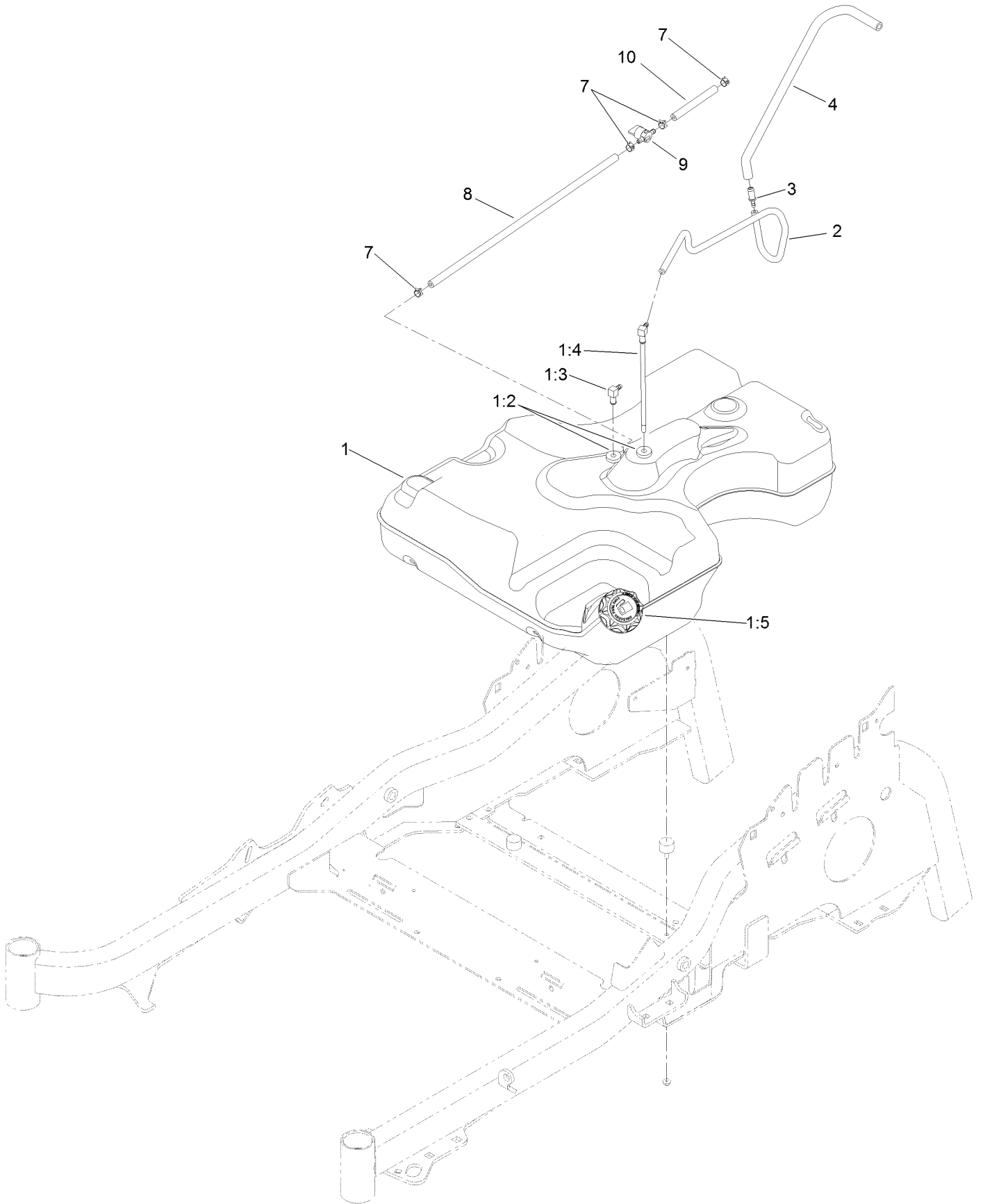

Fuel Tank and Hose Assembly (continued)

<i>Ref.</i>	<i>Part Number</i>	<i>Qty.</i>	<i>Description</i>	<i>Ref.</i>	<i>Part Number</i>	<i>Qty.</i>	<i>Description</i>
1	125-4765	1	Fuel Tank ASM	3	98-2952	1	Fitting-Straight
1:2	46-6560	2	Bushing	4	119-8562	1	Hose-Fuel
1:3	116-2288	1	Fitting-90 Elbow	7	2412-98	4	Clamp-Hose
1:4	125-4767	1	Fuel Line ASM	8	110-5701	1	Hose-Fuel
1:5	126-1789	1	Cap-Fuel, Ratcheting	9	1-603770	1	Valve-Fuel
2	119-6074	1	Hose-Fuel	10	109-0650	1	Hose-Fuel

Seat Mounting Assembly

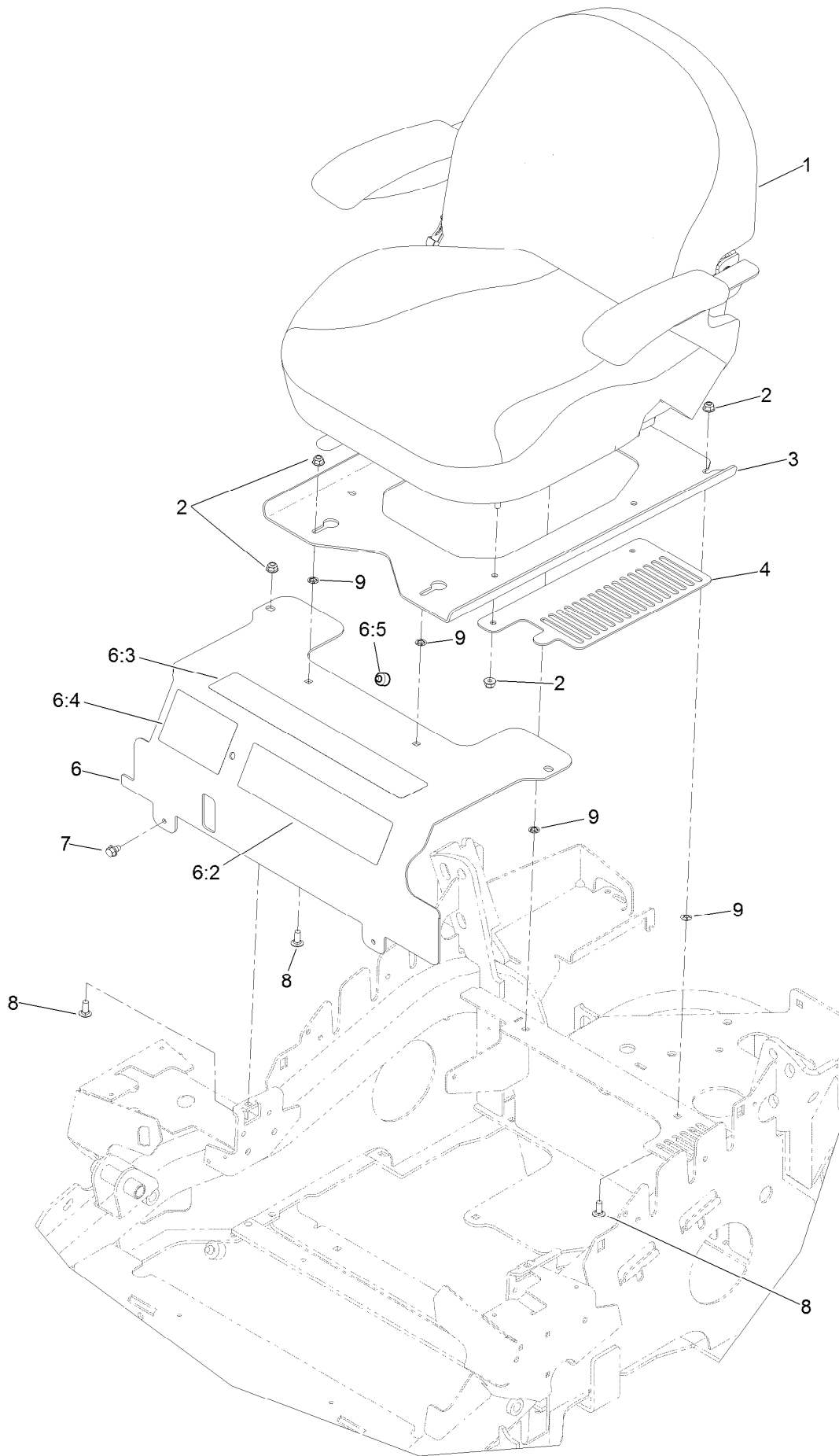

Seat Mounting Assembly (continued)

<i>Ref.</i>	<i>Part Number</i>	<i>Qty.</i>	<i>Description</i>	<i>Ref.</i>	<i>Part Number</i>	<i>Qty.</i>	<i>Description</i>
1	127-9538	1	Seat ASM	6:3	116-8722	1	Decal-Console
2	104-8300	10	Nut-Flange, NI	6:4	127-0325	1	Decal-Service Aid
3	117-8615-03	1	Plate-Mount, Seat	6:5	120-7893	1	Bumper-Grommet
4	117-8618-03	2	Plate-Cover, Fan	7	9266934	2	Screw
6	119-2597	1	Seat Mount Panel ASM	8	3230-23	6	Screw-CARR
6:2	114-5878	1	Decal	9	117-2749	4	Nut-Push

Seat Assembly No. 127-9538

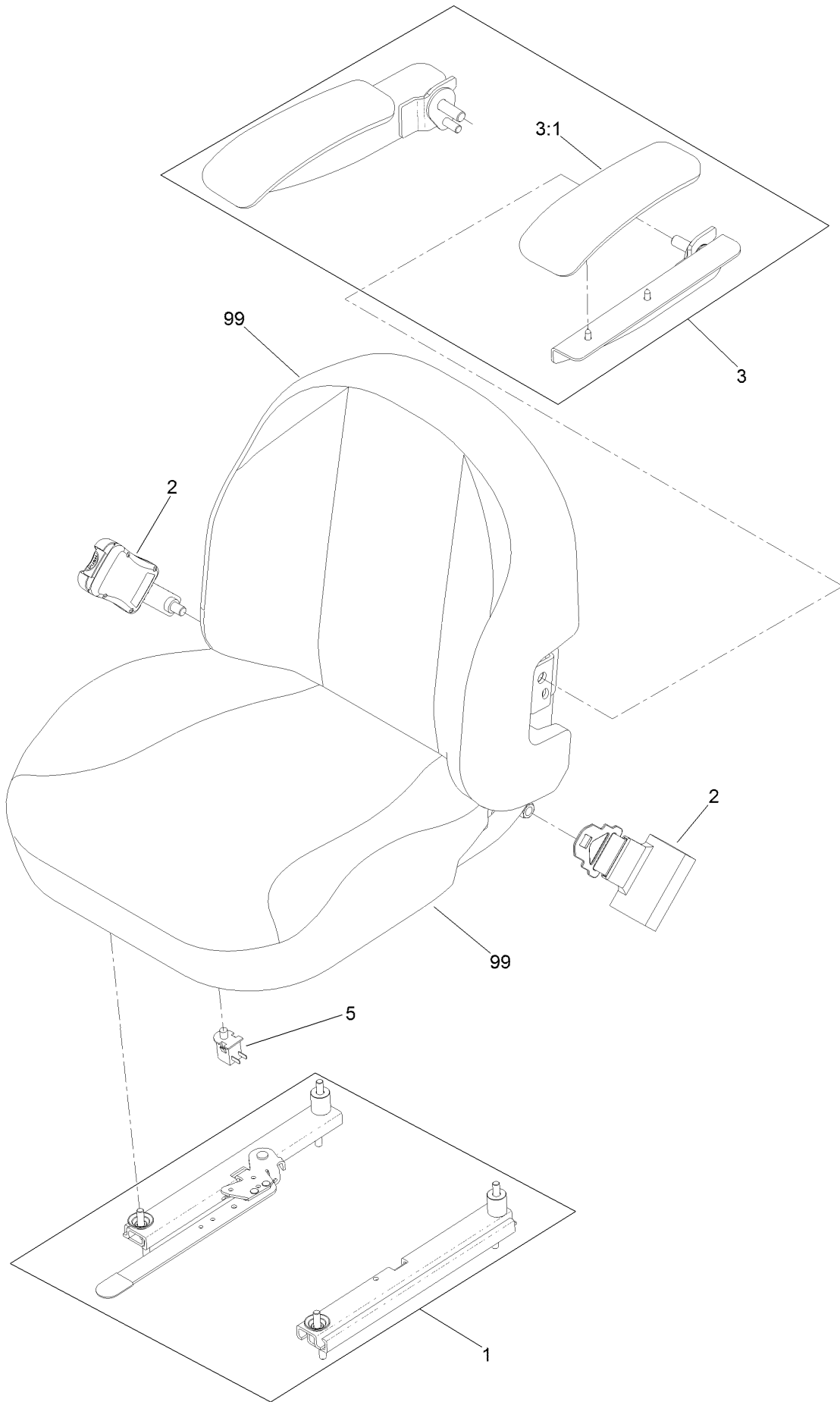

Seat Assembly No. 127-9538 (continued)

<i>Ref.</i>	<i>Part Number</i>	<i>Qty.</i>	<i>Description</i>	<i>Ref.</i>	<i>Part Number</i>	<i>Qty.</i>	<i>Description</i>
1	130-2853	1	Seat Track Kit	5	82-2190	1	Switch-Bail
2	130-2854	1	Seat Belt Kit	99	130-2856	1	Cover-Seat, Bottom
3	126-2058	1	Armrest Kit	99	130-2855	1	Cover-Seat, Back
3:1	110-4163	2	Cushion-Rest, Arm				

Motion Control Assembly

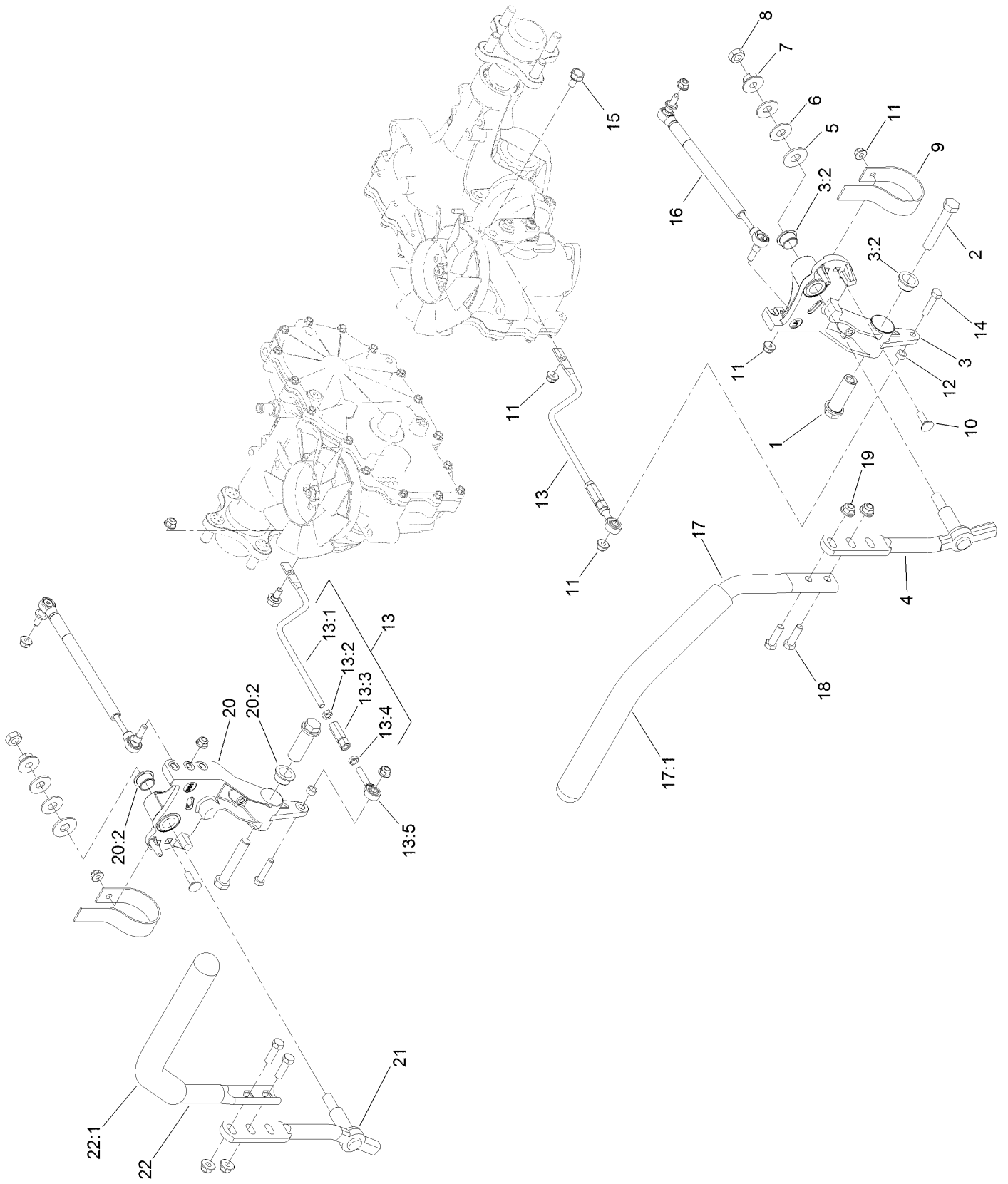

Motion Control Assembly (continued)

<i>Ref.</i>	<i>Part Number</i>	<i>Qty.</i>	<i>Description</i>	<i>Ref.</i>	<i>Part Number</i>	<i>Qty.</i>	<i>Description</i>
1	109-5891	2	Hub-Threaded	13:3	109-3728	1	Nut-Rod Adjustment
2	325-12	2	Screw-HH	13:4	3220-20	1	Nut-Jam
3	116-0881	1	LH Motion Control And Bushing ASM	13:5	2411-53	1	Bearing-Rod End, LH
3:2	109-8054	4	Bushing-Flange	14	322-7	2	Screw-HH
4	116-0040	1	Lever-Control Motion, LH	15	37-8771	2	Bolt-Shoulder
5	3256-6	2	Washer-Flat	16	116-0027	2	Damper-Control, Motion
6	109-9505	4	Washer-Spring	17	109-6590	1	LH Steering Handle ASM
7	32128-56	2	Nut-HF	17:1	109-5668	1	Grip-Control, Lever
8	3218-5	2	Nut-Jam	18	323-7	4	Screw-HH
9	109-5575	2	Spring-Leaf	19	104-8301	4	Nut-Flange, NI
10	3230-2	2	Bolt-CARR	20	116-0880	1	RH Motion Control And Bushing ASM
11	104-8300	10	Nut-Flange, NI	20:2	109-8054	4	Bushing-Flange
12	92-6998	2	Spacer-Yoke, Right	21	116-0039	1	Lever-Control Motion, RH
13	119-2605	2	Hydro Control Rod ASM	22	109-6589	1	RH Steering Handle ASM
13:1	119-2606	1	Rod-Control, Hydro	22:1	109-5668	1	Grip-Control, Lever
13:2	3220-2	1	Nut-Jam				

Parking Brake Assembly

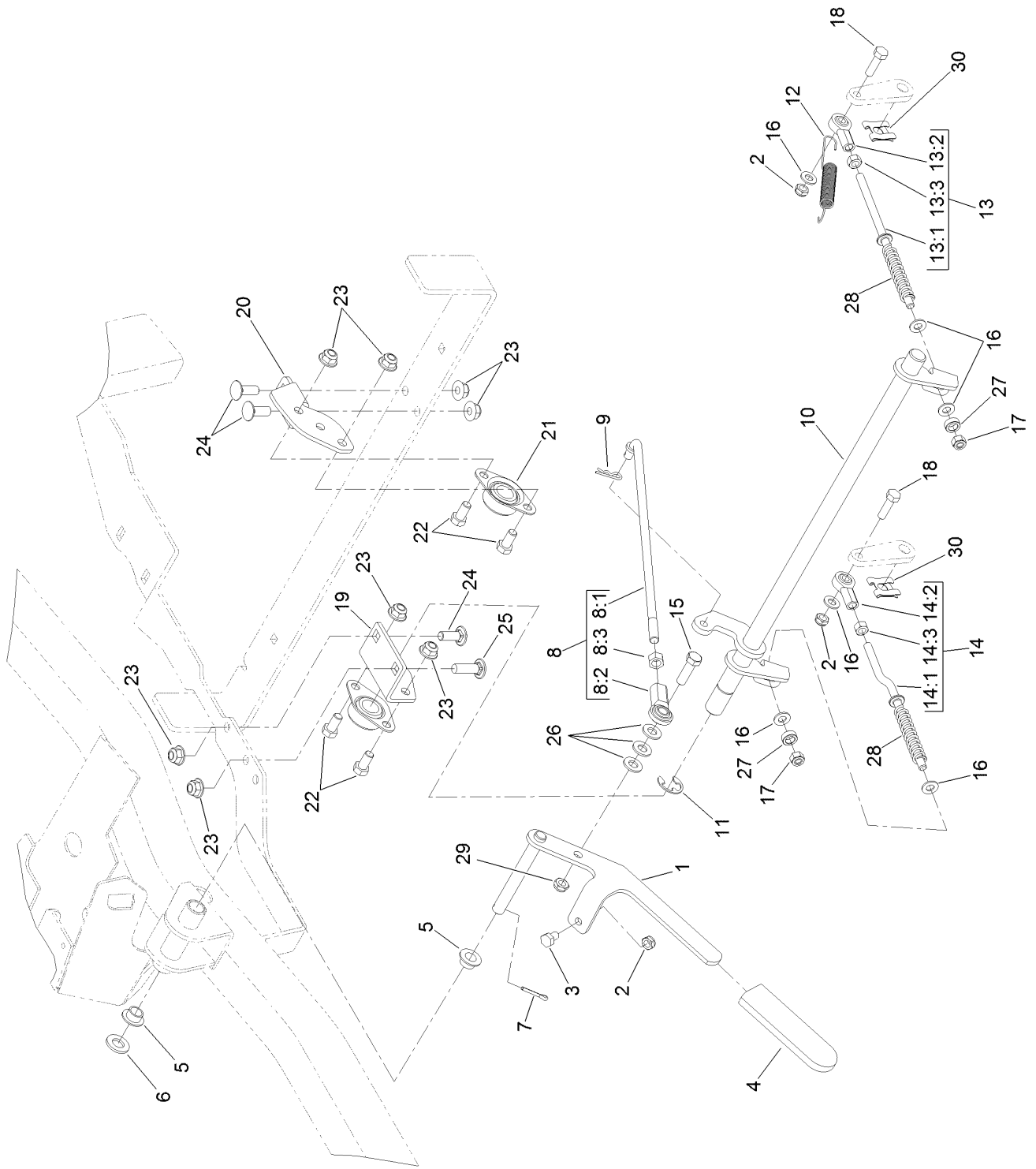

Parking Brake Assembly (continued)

<i>Ref.</i>	<i>Part Number</i>	<i>Qty.</i>	<i>Description</i>	<i>Ref.</i>	<i>Part Number</i>	<i>Qty.</i>	<i>Description</i>
1	121-4766-03	1	Handle-Brake	14:1	121-4770	1	Rod-Brake
2	3296-47	3	Nut-Lock, NI	14:2	1-543017	1	Balljoint-RH
3	322-1	1	Screw-HH	14:3	3219-2	1	Nut-Hex
4	1-633268	1	Grip-Lever	15	323-7	1	Screw-HH
5	1-513140	2	Bearing-Control	16	3256-23	6	Washer-Flat
6	106-9888	1	Washer-Flat	17	3296-4	2	Nut-Lock
7	3272-10	1	Pin-Cotter	18	322-16	2	Screw-HH
8	121-4807	1	Brake Link ASM	19	121-4761-01	1	Bracket-Shaft Mount, RH
8:1	121-4795	1	Rod-Link, Brake	20	121-4793-01	1	Bracket-Shaft Mount, LH
8:2	103-0608	1	Joint-Ball, End	21	1-633102	2	Bearing-Flange, Side
8:3	3219-3	1	Nut-Hex	22	323-4	4	Screw-HH
9	3290-307	1	Pin-Cotter	23	104-8301	8	Nut-Flange, NI
10	121-4804-03	1	Shaft-Brake	24	3231-22	3	Screw-CARR
11	32151-48	1	E-Ring	25	3231-28	1	Screw-CARR
12	110769	1	Spring-Extension	26	3256-24	3	Washer-Flat
13	121-4805	1	LH Brake Rod ASM	27	103-5677	2	Spacer
13:1	121-4755	1	Rod-Brake	28	1-603807	2	Spring-Return, Neutral
13:2	1-543017	1	Balljoint-RH	29	3296-59	1	Nut-Lock, NI
13:3	3219-2	1	Nut-Hex	30	114-8450	2	Clip-Retaining
14	121-4806	1	RH Brake Rod ASM				

Engine, Muffler and Control Panel Assembly

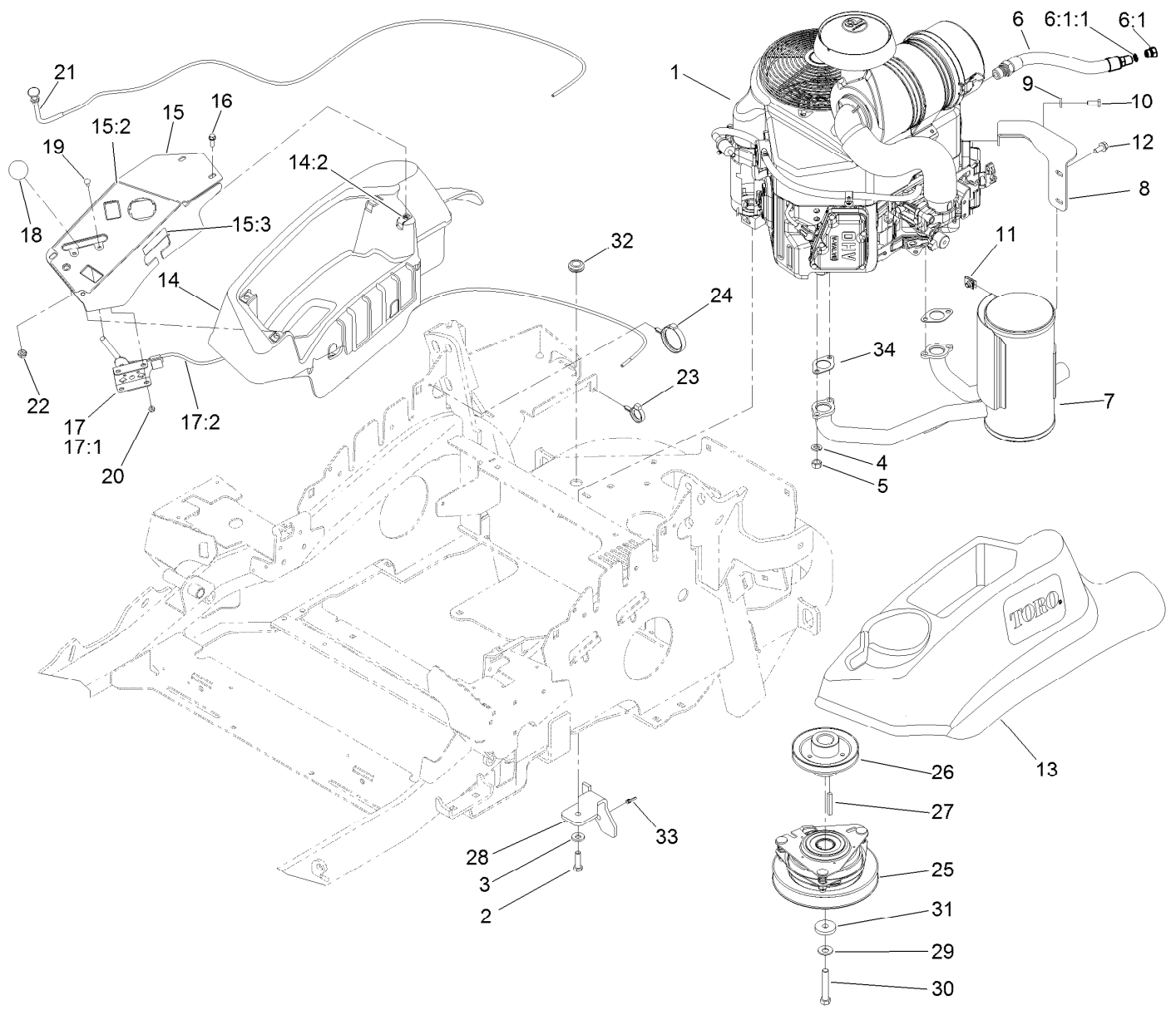

Engine, Muffler and Control Panel Assembly (continued)

<i>Ref.</i>	<i>Part Number</i>	<i>Qty.</i>	<i>Description</i>	<i>Ref.</i>	<i>Part Number</i>	<i>Qty.</i>	<i>Description</i>
1		1	Engine-Kawasaki, Fx651V-S10-R ●■	16	32105-15	4	Screw-HWH
2	323-7	4	Screw-HH	17	110-5727	1	Throttle Control ASM
3	98-5975	4	Washer-Belleville	17:1	112-2334	1	Lever-Throttle
4	114-3550	4	Washer-Lock, Spring	17:2	110-5728	1	Cable-Throttle
5	114-3549	4	Nut	18	1-603175	1	Knob-Ball
6	116-4924	1	Engine Oil Drain Hose ASM	19	1-807513	2	Bolt-CARR
6:1	353-508	1	Plug-HH	20	3296-2	2	Nut-Lock, NI
6:1:1	237-42	1	O-Ring	21	115-2753	1	Control-Choke
7	119-2645	1	Muffler	22	3220-3	1	Nut-HJ
8	119-2659	1	Bracket-Muffler	23	105-1853	1	Clamp-Hose
9	1-303334	1	Washer-Spring	24	117-7817	1	Clamp-Harness
10	33114-020	1	Screw-HH	25	119-2595	1	Clutch
11	94-2413	2	U-Nut	26	119-9915	1	Pulley-Engine
12	3234-5	2	Screw-HHF	27	608006	1	Key-Square
13	119-2602	1	LH Console ASM	28	119-2658-01	1	Bracket-Stop, Clutch
14	119-2603	1	RH Console ASM	29	1-603610	1	Washer-Spring
14:2	107069	4	Clip	30	3212-10	1	Screw-HH
15	119-2694	1	Control Panel ASM	31	107-4136	1	Washer
15:2	119-2501	1	Decal-Panel, Control	32	112-7069	1	Grommet
15:3	114-4466	1	Decal-Fuses	33	1-303287	1	Tie-Cable
				34	1-653313	2	Gasket-Exhaust

● Not serviced separately

■ Obtain parts from www.kawpowerepc.com

Deck Lift Assembly

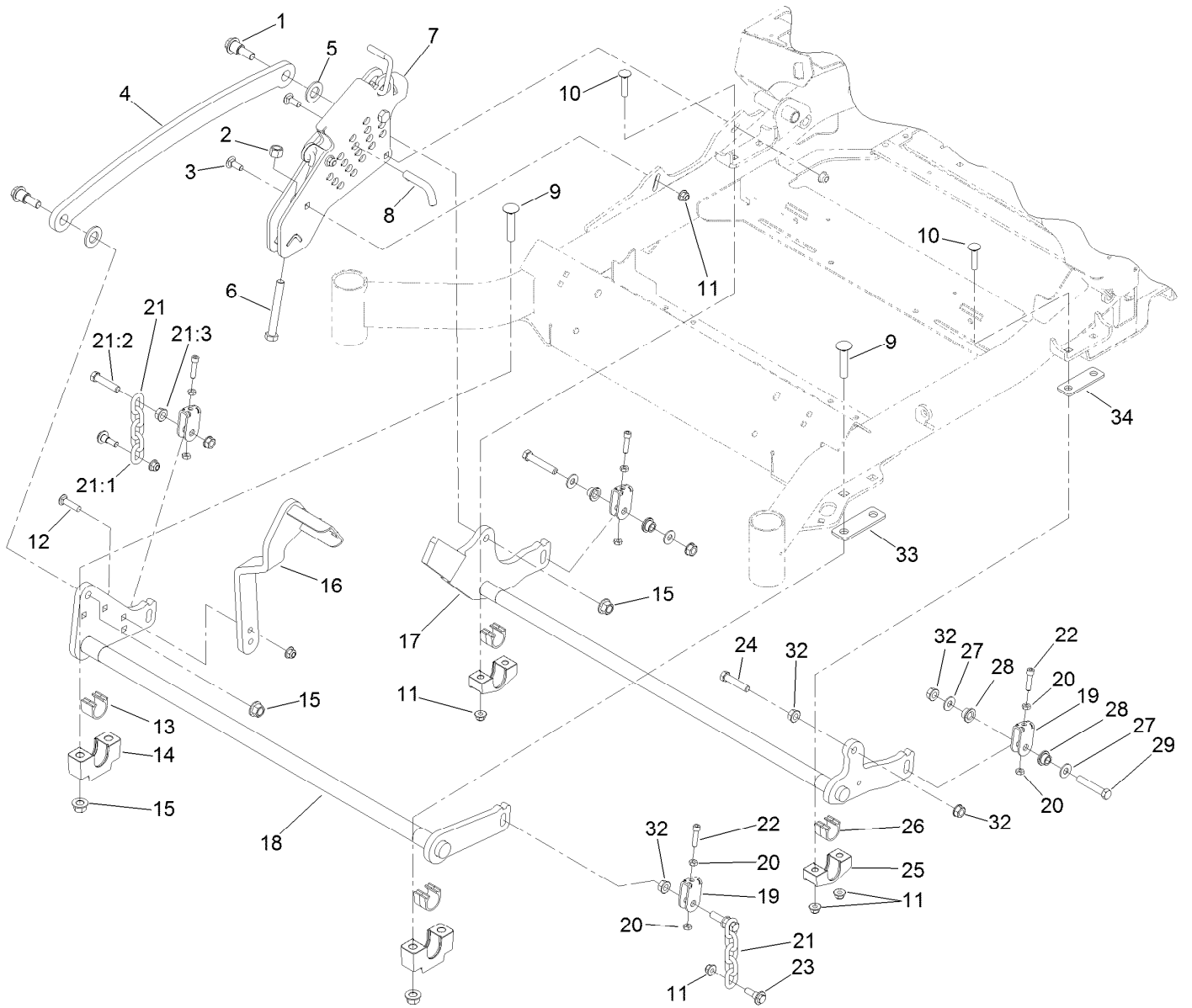

Deck Lift Assembly (continued)

<i>Ref.</i>	<i>Part Number</i>	<i>Qty.</i>	<i>Description</i>	<i>Ref.</i>	<i>Part Number</i>	<i>Qty.</i>	<i>Description</i>
1	116-0780	2	Screw-HHF, Shoulder	19	109-9066	4	Yoke-Adjust, Deck
2	3296-23	1	Nut-Lock, NI	20	3218-2	8	Nut-Jam
3	3231-2	2	Bolt-CARR	21	116-0756	2	Deck Lift Chain ASM
4	116-0797-03	1	Link-Lift, Deck	21:1	1-633447	1	Chain-Lift, Deck
5	3256-28	2	Washer-Flat	21:2	109-9065	1	Screw-HH
6	116-0559	1	Bolt-TAP	21:3	32128-37	1	Nut-HF
7	121-4779	1	Height Of Cut ASM	22	322-47	4	Screw-HH
8	116-5584	1	Pin-HOC	23	109-9840	2	Screw-Shoulder, HHF
9	116-1700	4	Bolt-CARR	24	109-9065	1	Screw-HH
10	3231-5	4	Screw-CARR	25	116-0818-03	2	Support-Cross Shaft, Rear Bearing
11	104-8301	10	Nut-Flange, NI	26	109-7173	2	Bearing-Cross Shaft, Rear
12	3231-4	2	Screw-CARR	27	3256-4	4	Washer-Flat
13	109-9410	2	Bearing-Cross Shaft, Front	28	116-2428	4	Bushing-Flanged
14	109-9409	2	Support-Cross Shaft, Front Bearing	29	324-10	2	Screw-HH
15	99-5107	6	Nut-Lock	32	32128-37	6	Nut-HF
16	120-7877-01	1	Lever-Foot	33	121-7593-01	2	Spacer-Decklift, Front
17	116-0459-03	1	Lift-Deck, Rear	34	121-7594-01	2	Spacer-Decklift, Back
18	126-2475-03	1	Decklift-Front				

Height-of-Cut Assembly No. 121-4779

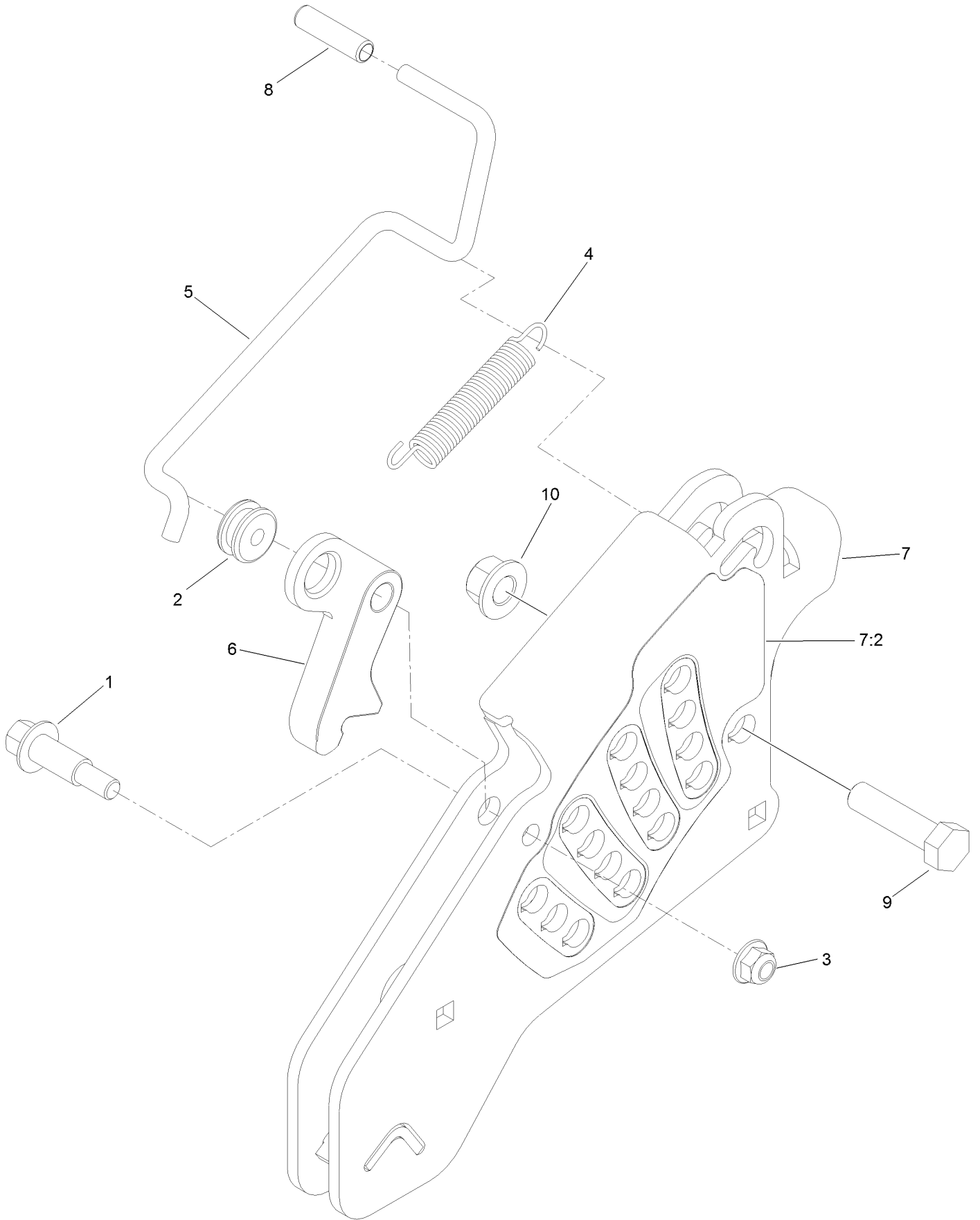

Height-of-Cut Assembly No. 121-4779 (continued)

<i>Ref.</i>	<i>Part Number</i>	<i>Qty.</i>	<i>Description</i>	<i>Ref.</i>	<i>Part Number</i>	<i>Qty.</i>	<i>Description</i>
1	62-1330	1	Bolt-Shoulder	7	121-4778	1	HOC Plate ASM
2	109-7130	1	Grommet	7:2	121-4777	1	Decal-HOC Ce
3	104-8301	1	Nut-Flange, NI	8	109-8250	1	Grip-Lever
4	109-7124	1	Spring-Extension	9	325-8	1	Screw-HH
5	109-7128	1	Rod-Lock, Transport	10	99-5107	1	Nut-Lock
6	116-0118	1	Pawl-Transport, HOC				

Deck Assembly

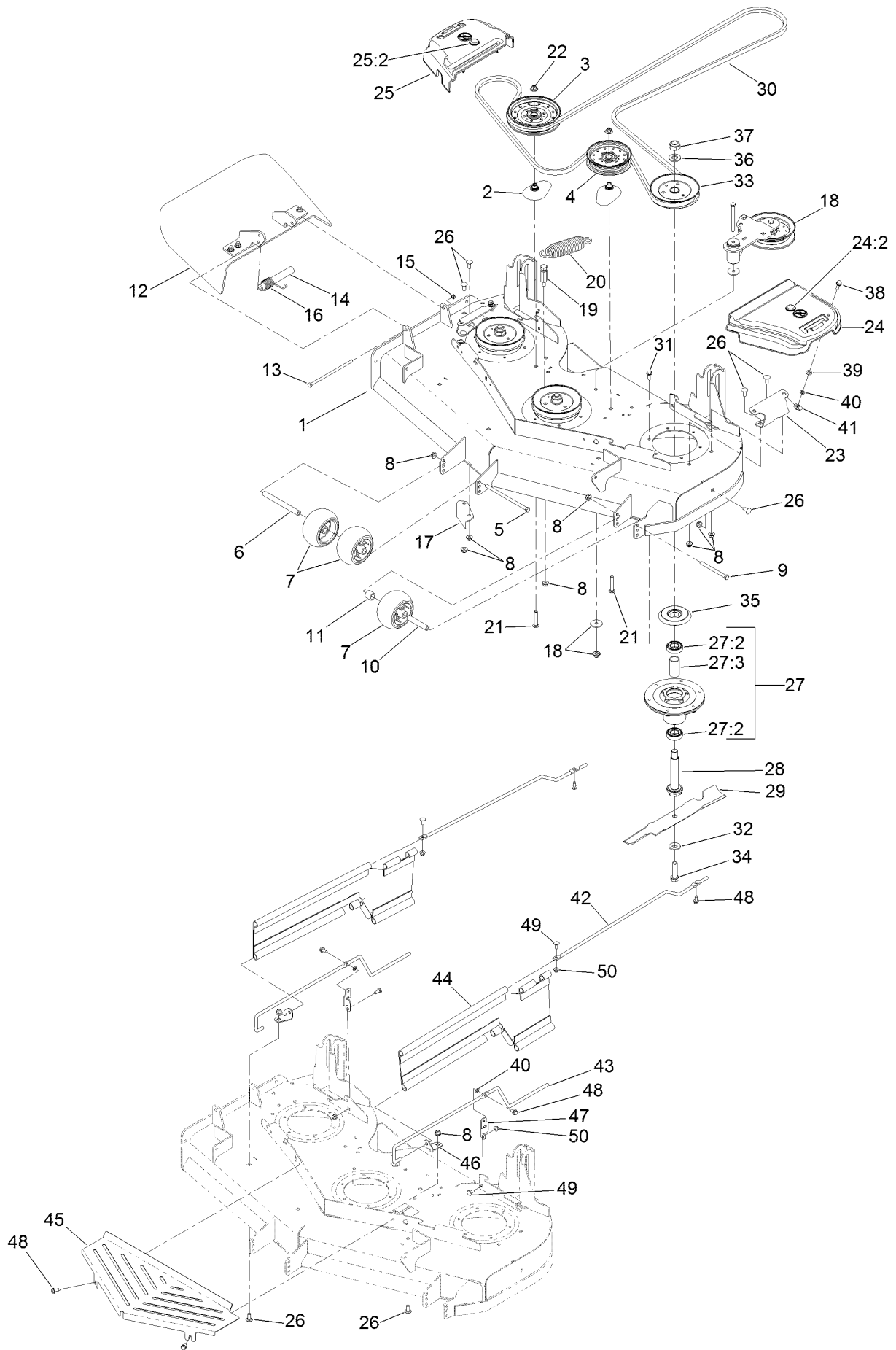

Deck Assembly (continued)

<i>Ref.</i>	<i>Part Number</i>	<i>Qty.</i>	<i>Description</i>	<i>Ref.</i>	<i>Part Number</i>	<i>Qty.</i>	<i>Description</i>
1	131-7664	1	Deck ASM	26	3231-27	10	Screw-CARR
2	109-2872	2	Spacer-Pulley	27	120-5477	3	Spindle ASM
3	116-4670	1	Pulley-Idler, Flat	27:2	116-0720	2	Bearing-Ball
4	116-4665	1	Idler-Pulley, Flat	27:3	115-2641	1	Spacer-Bearing
5	108-5388	1	Screw-HH	28	120-2505	3	Spindle-Shaft
6	98-5967	1	Spacer-Wheel	29	117-7277-03	3	Blade-Hi Flo, 16.50 Inch
7	1-603299	3	Roller-Scalp, Anti	30	119-9926	1	Belt-V
8	104-8301	13	Nut-Flange, NI	31	32144-41	18	Screw-Taptite
9	323-23	1	Screw-HH	32	125-1736	3	Washer-Belleville
10	98-7912	1	Tube-Spanner	33	120-7854	3	Pulley-B Section
11	98-7913	1	Tube-Spacer	34	51-4060	3	Screw-Blade
12	120-2451	1	Deflector ASM	35	117-7210	3	Shield-Bearing
13	322-50	1	Screw-HH	36	92-5836	3	Washer
14	105-4622	1	Spacer	37	3296-67	3	Nut-Lock, NI
15	3296-47	1	Nut-Lock, NI	38	3234-29	2	Screw-HHF
16	108-4052	1	Spring-Torsion	39	73-0041	2	Washer-Thrust
17	107-8541-01	1	Baffle-Discharge	40	117-2749	4	Nut-Push
18		1	Idler Arm ASM ●	41	94-2413	2	U-Nut
19	114-5867	1	Anchor-Spring, Tall	42	131-3999	2	Rod-Support, Upper
20	116-6317	1	Spring-Extension	43	131-4000	2	Rod-Support, Lower
21	3231-40	2	Bolt-CARR, Short Neck	44	131-4023	2	Guard-Side
22	109-6658	2	Nut-Flange, NI	45	131-3979-03	1	Shield-Front
23	114-5881-01	2	Bracket-Cover, Belt	46	131-4001-03	2	Bracket-Support, Front Rod
24	117-7814	1	LH Belt Cover ASM	47	131-4193-03	2	Bracket-Mounting, Rear
24:2	117-3824	1	Plug-Plastic	48	32144-70	6	Screw-HWHTF
25	117-7813	1	RH Belt Cover ASM	49	3230-23	4	Screw-CARR
25:2	117-3824	1	Plug-Plastic	50	104-8300	4	Nut-Flange, NI

● Not serviced separately

Deck Decal Assembly No. 131-7664

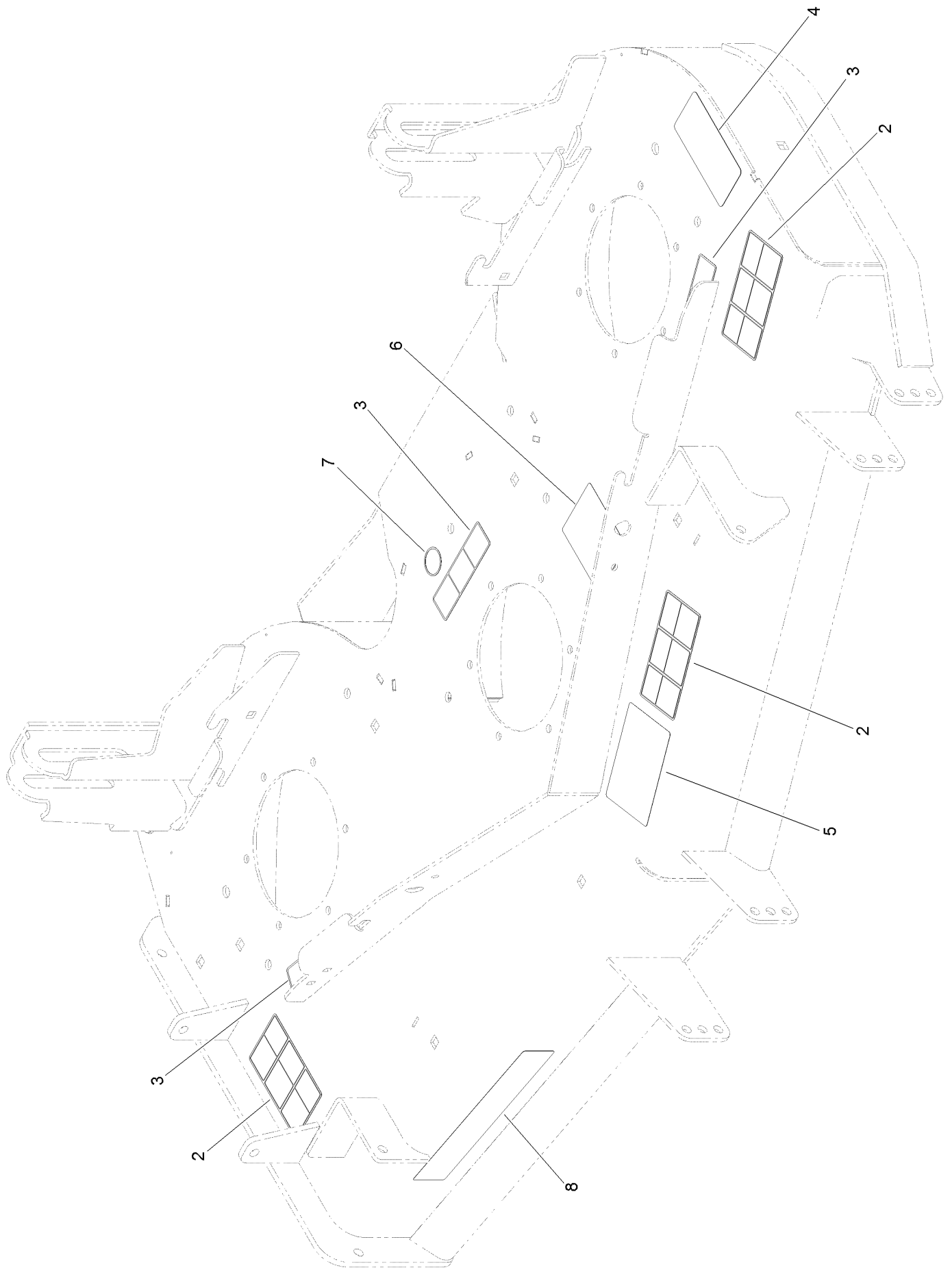

Deck Decal Assembly No. 131-7664 (continued)

<i>Ref.</i>	<i>Part Number</i>	<i>Qty.</i>	<i>Description</i>	<i>Ref.</i>	<i>Part Number</i>	<i>Qty.</i>	<i>Description</i>
2	117-3848	3	Decal-Danger	6	117-8639	1	Decal-Routing, Deck Belt
3	112-9028	3	Decal-Cover Missing	7	58-6520	1	Decal-Grease
4	93-7818	1	Decal-Torque, Blade Bolt	8	121-3204	1	Decal
5	112-3858	1	Decal-Anti Scalp				

Deflector Assembly No. 120-2451

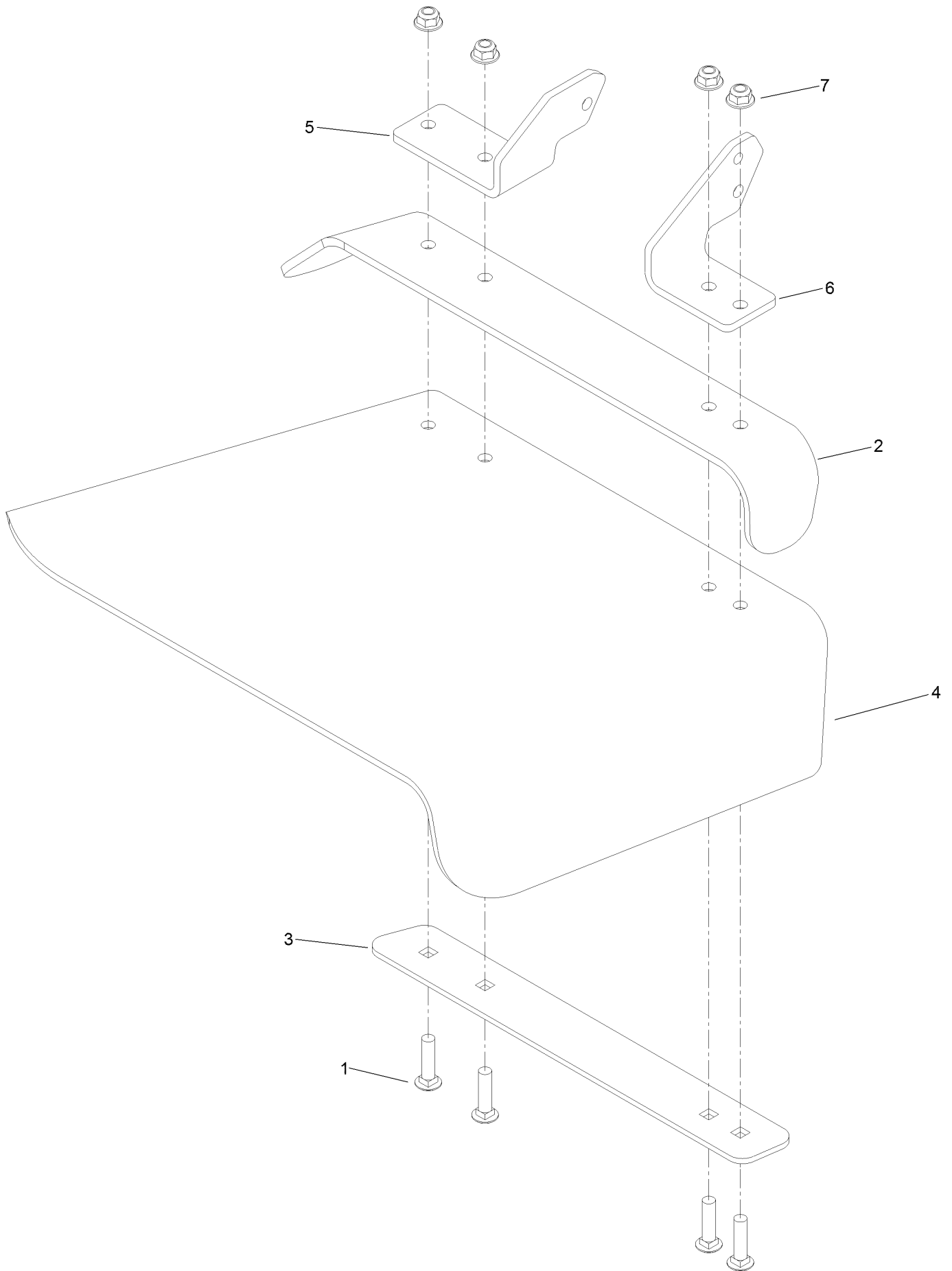

Deflector Assembly No. 120-2451 (continued)

<i>Ref.</i>	<i>Part Number</i>	<i>Qty.</i>	<i>Description</i>	<i>Ref.</i>	<i>Part Number</i>	<i>Qty.</i>	<i>Description</i>
1	3231-4	4	Screw-CARR	5	108-4059-01	1	Plate-Hinge, Rear
2	106-3246-01	1	Deflector	6	106-3253-01	1	Plate-Hinge, Front
3	106-3248-03	1	Strap-Discharge	7	104-8301	4	Nut-Flange, NI
4	110-0759	1	Deflector-Rubber				

Idler Assembly

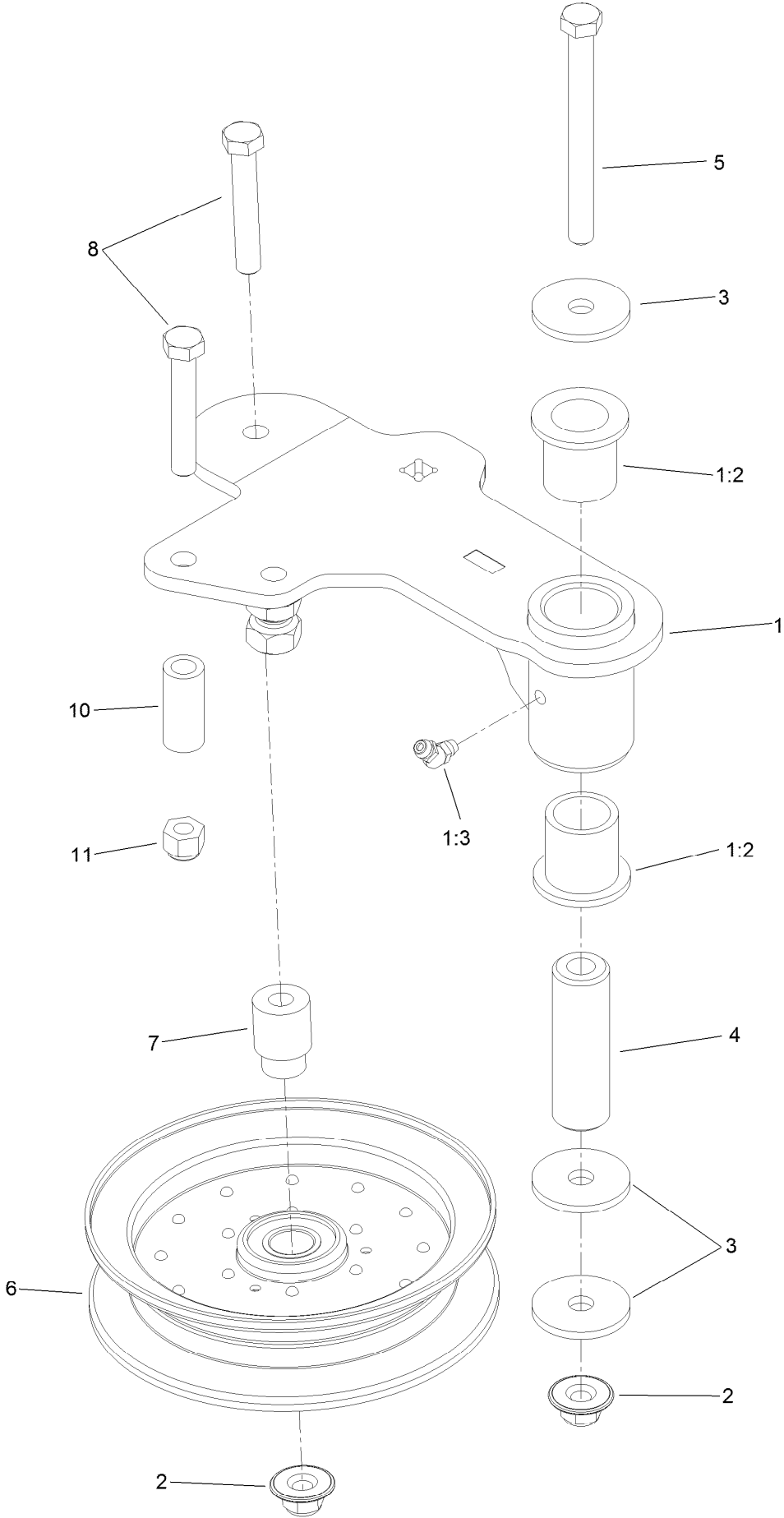

Idler Assembly (continued)

<i>Ref.</i>	<i>Part Number</i>	<i>Qty.</i>	<i>Description</i>	<i>Ref.</i>	<i>Part Number</i>	<i>Qty.</i>	<i>Description</i>
1	120-2501	1	Idler Arm ASM	5	98-5961	1	Screw-HH
1:2	1-303514	2	Bearing-Flanged	6	116-4668	1	Idler-Pulley, Flanged
1:3	1481	1	Fitting-Grease	7	112-4212	1	Mount-Pulley
2	109-6658	2	Nut-Flange, NI	8	323-11	2	Screw-HH
3	1-213069	3	Washer	10	104-0151	1	Spacer
4	114-5848	1	Spacer-Plain	11	3296-39	1	Nut-Lock, NI

Electrical Assembly

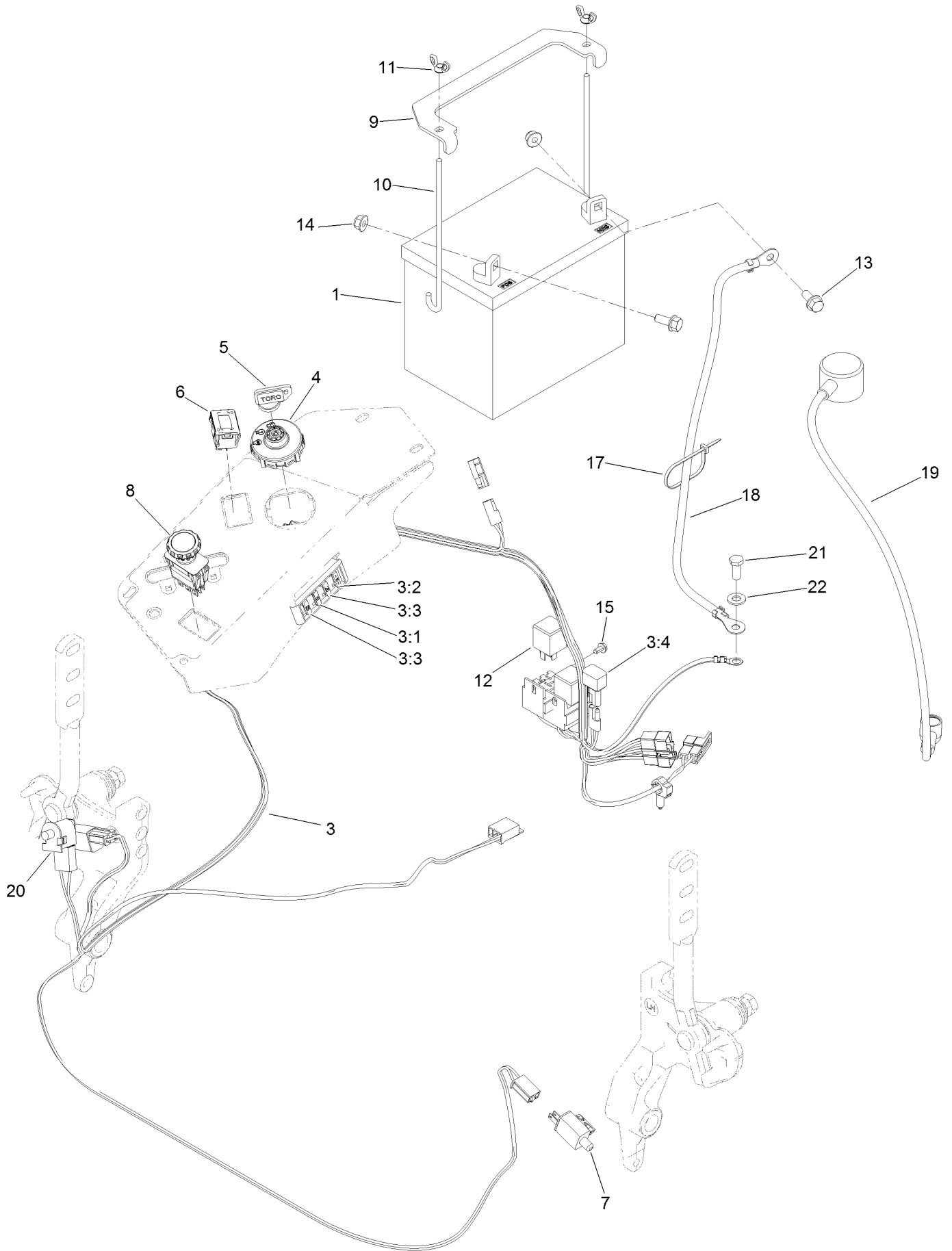

Electrical Assembly (continued)

<i>Ref.</i>	<i>Part Number</i>	<i>Qty.</i>	<i>Description</i>	<i>Ref.</i>	<i>Part Number</i>	<i>Qty.</i>	<i>Description</i>
1	104-8162	1	Battery-Dry	10	1-633651	2	Bolt-Holddown
3	117-2582	1	Harness-Wire	11	1-543792	2	Wingnut
3:1	218-578	1	Fuse-Blade, 10 Amp	12	1-643275	2	Relay
3:2	109355	1	Fuse-Blade, 15 Amp	13	3234-5	2	Screw-HHF
3:3	109102	2	Fuse-Blade, 25 Amp	14	104-8300	2	Nut-Flange, NI
3:4	116-0053	1	Cap-Plug	15	104-2065	1	Screw-HWH
4	117-2221	1	Switch-Ignition	17	1-303287	3	Tie-Cable
5	63-8360	1	Key-Ignition	18	114-1218	1	Cable-Battery, Negative
6	120-2244	1	Hourmeter	19	115-3864	1	Cable-Battery, Positive
7	110-6765	2	Switch	20	82-2190	1	Switch-Bail
8	116-0124	1	Switch-PTO, 10A	21	33114-020	1	Screw-HH
9	116-0042-03	1	Strap-Tie Down, Battery	22	33094-00	1	Washer-Plain

Attachments and Accessories

For 74142TE Z Master Commercial 2000 Series Riding Mower with 48IN TURBO FORCE Side Discharge Mower

Product Name	Model/Part
Deluxe Seat Kit.....	121-7595
Operator Controlled Discharge Chute Kit.....	117-3600
Bimini Folding Shade Assembly	115-4510
Z Stand Kit.....	121-4811
Recycler Kit	120-2401
E-Z VAC Twin Soft Bagger.....	78569
Light Kit.....	116-1154
E-Z Vac Blower and Drive Kit.....	78571
Trash Holder Kit.....	TC26
Blade-Hi Flo, 16.50in	117-7277-03
Blade-Mulch, 16.50in.....	117-7278-03
Hypr-Oil 500 (quart).....	114-4713
Hypr-Oil 500 (gallon).....	114-4714
Hypr-Oil 500-5 (5 gallon).....	114-4715
MVP Filter, Belt and Blade Kit.....	127-1631
Filter Minder Gauge	99-4664
Toro Deluxe Rider Cover.....	490-7319
Spark Arrestor Screen	75-6880

Notes:

Notes:

Notes:



Count on it.