



**Count on it.**

**Operator's Manual**

# 21in Heavy-Duty Recycler®/Rear Bagger Lawn Mower

Model No. 22290—Serial No. 314000001 and Up

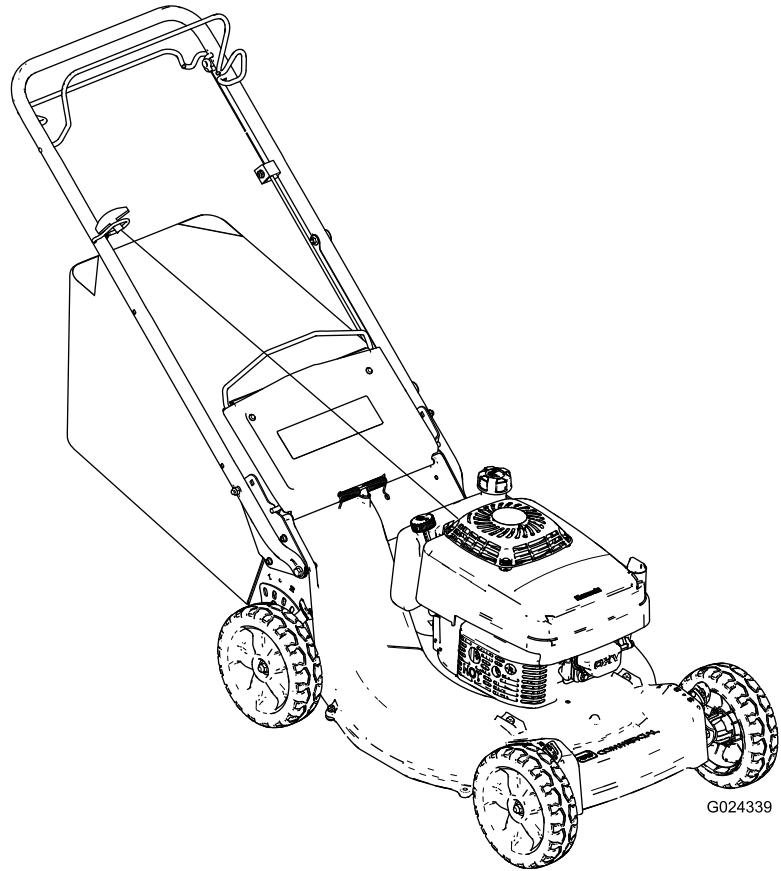

G024339



# Introduction

This rotary-blade, walk-behind lawn mower is intended to be used by residential homeowners or professional, hired operators. It is designed primarily for cutting grass on well-maintained lawns on residential or commercial properties. It is not designed for cutting brush or for agricultural uses.

Read this information carefully to learn how to operate and maintain your product properly and to avoid injury and product damage. You are responsible for operating the product properly and safely.

You may contact Toro directly at [www.Toro.com](http://www.Toro.com) for product and accessory information, help finding a dealer, or to register your product.

Whenever you need service, genuine Toro parts, or additional information, contact an Authorized Service Dealer or Toro Customer Service and have the model and serial numbers of your product ready. Figure 1 identifies the location of the model and serial numbers on the product. Write the numbers in the space provided.

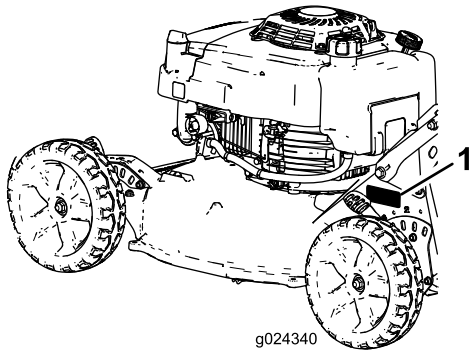

Figure 1

1. Model and serial number location

<b>Model No.</b> _____
<b>Serial No.</b> _____

This manual identifies potential hazards and has safety messages identified by the safety alert symbol (Figure 2), which signals a hazard that may cause serious injury or death if you do not follow the recommended precautions.



Figure 2

1. Safety alert symbol

This manual uses 2 words to highlight information.

**Important** calls attention to special mechanical information and **Note** emphasizes general information worthy of special attention.

## WARNING

### CALIFORNIA Proposition 65 Warning

**This product contains a chemical or chemicals known to the State of California to cause cancer, birth defects, or other reproductive harm.**

**The engine exhaust from this product contains chemicals known to the State of California to cause cancer, birth defects, or other reproductive harm.**

**Important:** This engine is not equipped with a spark arrester muffler. It is a violation of California Public Resource Code Section 4442 to use or operate the engine on any forest-covered, brush-covered, or grass-covered land. Other states or federal areas may have similar laws.

This spark ignition system complies with Canadian ICES-002.

The enclosed *Engine Owner's Manual* is supplied for information regarding the US Environmental Protection Agency (EPA) and the California Emission Control Regulation of emission systems, maintenance, and warranty. Replacements may be ordered through the engine manufacturer.

### Net Torque

The gross or net torque of this engine was laboratory rated by the engine manufacturer in accordance with the Society of Automotive Engineers (SAE) J1940. As configured to meet safety, emission, and operating requirements, the actual engine torque on this class of mower will be significantly lower.

# Contents

Safety .....	3
General Safety.....	3
Safety and Instructional Decals .....	5
Setup .....	7
1 Installing the Handle .....	7
2 Installing the Recoil-Start Rope.....	9
3 Filling the Crankcase with Oil .....	9
4 Adjusting the Self-Propel Drive.....	10
5 Assembling the Grass Bag.....	10
Product Overview .....	11
Operation .....	11
Checking the Engine-Oil Level.....	12
Filling the Fuel Tank with Gasoline .....	12
Adjusting the Cutting Height.....	12
Starting the Engine .....	13
Stopping the Engine .....	13
Operating the Self-Propel Drive .....	13
Recycling the Clippings .....	13
Bagging the Clippings .....	14
Operating Tips .....	15
Maintenance .....	16
Recommended Maintenance Schedule(s) .....	16
Engine Maintenance .....	17
Servicing the Air Cleaner .....	17
Changing the Engine Oil .....	17
Servicing the Spark Plug .....	18
Drive System Maintenance .....	18
Adjusting the Self-Propel Drive .....	18
Blade Maintenance .....	19
Maintaining the Blade .....	19
Cleaning .....	21
Cleaning under the Machine.....	21
Storage .....	22
Preparing the Fuel System .....	22
Preparing the Engine .....	22
General Information.....	22
Removing the Machine from Storage.....	22
Troubleshooting .....	23

# Safety

This machine meets or exceeds the CPSC blade safety requirements for walk-behind rotary lawn mowers.

**Improperly using or maintaining this lawn mower can result in injury. To reduce the potential for injury, comply with these safety instructions.**

Toro designed and tested this lawn mower for to offer reasonably safe service; however, **failure to comply with the following instructions may result in personal injury.**

## **⚠ WARNING**

**Engine exhaust contains carbon monoxide, an odorless, deadly poison that can kill you.**

**Do not run the engine indoors or in an enclosed area.**

**To ensure maximum safety, best performance, and to gain knowledge of the product, it is essential that you and any other operator of the lawn mower read and understand the contents of this manual before the engine is ever started. Pay particular attention to the safety alert symbol (Figure 2) which means Caution, Warning, or Danger. Read and understand the instruction because it has to do with safety. Failure to comply with the instruction may result in personal injury.**

## General Safety

This machine is capable of amputating hands and feet and of throwing objects. Failure to observe the following safety instructions could result in serious injury or death.

The following instructions have been adapted from the ANSI/OPEI B71.4-2012 standard.

## Training

- Read the *Operator's Manual* and other training material. If the operator(s) or mechanic(s) cannot read English, it is the owner's responsibility to explain this material to them.
- Become familiar with the safe operation of the equipment, operator controls, and safety signs.
- All operators and mechanics should be trained. The owner is responsible for training the users.
- Never let children or untrained people operate or service the equipment. Local regulations may restrict the age of the operator.
- The owner/user can prevent and is responsible for accidents or injuries occurring to themselves, other people, or property.

## Preparation

- Use only accessories and attachments approved by the manufacturer.

- Wear appropriate clothing including hard hat, safety glasses, and ear protection. Long hair, loose clothing or jewelry may get tangled in moving parts.
- Inspect the area where the equipment is to be used and remove all objects, such as rocks, toys, and wire, which can be thrown by the machine.
- Check that operator's presence controls, safety switches, and shields are attached and functioning properly. Do not operate the machine unless they are functioning properly.

## Safe Handling of Fuels

- To avoid personal injury or property damage, use extreme care in handling gasoline. Gasoline is extremely flammable and the vapors are explosive.
- Extinguish all cigarettes, cigars, pipes, and other sources of ignition.
- Use only an approved fuel container.
- Never remove fuel cap or add fuel with the engine running.
- Allow the engine to cool before refueling.
- Never refuel the machine indoors.
- Never store the machine or the fuel container where there is an open flame, spark, or pilot light, such as on a water heater or on other appliances.
- Never fill containers inside a vehicle or on a truck or trailer bed with a plastic liner. Always place containers on the ground away from your vehicle before filling.
- Remove the equipment from the truck or trailer and refuel it on the ground. If this is not possible, then refuel such equipment with a portable container rather than from a fuel dispenser nozzle.
- Keep the nozzle in contact with the rim of the fuel tank or container opening at all times until fueling is complete.
- Do not use a nozzle lock open device.
- If fuel is spilled on clothing, change clothing immediately.
- Never overfill the fuel tank. Replace fuel cap and tighten securely.

## Operation

- Never run an engine in an enclosed area.
- Operate the machine only in good light, keeping away from holes and hidden hazards.
- Start the engine only from the operating position.
- Be sure of your footing, especially when backing up. Walk, don't run. Never operate the machine on wet grass. Reduced footing could cause slipping.
- Slow down and use extra care on hillsides. Be sure to travel side to side on hillsides. Turf conditions can affect the stability of the machine. Use caution while operating the machine near drop-offs.
- Do not operate the machine without either the grass catcher or the guard in place.

- Do not change the engine governor setting or overspeed the engine.
- Stop the machine on level ground and shut off the engine before leaving the operating position for any reason, including emptying the catcher or unclogging the chute.
- Stop the machine and inspect the blade after striking objects or if an abnormal vibration occurs. Make necessary repairs to the machine before resuming operation.
- Keep hands and feet away from the cutting units.
- Look behind and down before backing up to be sure of a clear path.
- Keep pets and bystanders away.
- Slow down and use caution when crossing roads and sidewalks. Stop the blade if you are not mowing.
- Be aware of the machine discharge direction and do not point it at anyone.
- Do not operate the machine while under the influence of alcohol or drugs.
- Use care when loading or unloading the machine into a trailer or truck.
- Use care when approaching blind corners, shrubs, trees, or other objects that may obscure vision.

## Maintenance and Storage

- Stop the engine and disconnect the spark-plug wire. Wait for all movement to stop before adjusting, cleaning, or repairing the machine.
- Clean grass and debris from the cutting unit, drive, muffler, and engine to help prevent fires. Clean up oil or fuel spills.
- Let the engine cool before storing the machine, and do not store it near a flame.
- Shut off the fuel while storing or transporting the machine. Do not store fuel near flames or drain fuel indoors.
- Never allow untrained personnel to service the machine.
- Remove the spark-plug wire before making any repairs.
- Use care when checking the blade. Wrap the blade or wear gloves, and use caution when servicing the blade. Only replace the blade; never straighten or weld it.
- Keep hands and feet away from moving parts. If possible, do not make adjustments to the machine while the engine is running.
- Keep all parts in good working condition and all hardware tightened. Replace all worn or damaged decals.
- To best protect your investment and maintain optimal performance of your Toro equipment, count on Toro genuine parts. When it comes to reliability, Toro delivers replacement parts designed to the exact engineering specifications of our equipment. For peace of mind, insist on Toro genuine parts.

## Hauling

- Use care when loading or unloading the machine into a trailer or truck.

- Use full-width ramps for loading the machine into a trailer or a truck.
- Tie the machine down securely using straps, chains, cable, or ropes. Both the front and the rear straps should be directed down and outward from the machine.

## Safety and Instructional Decals



Safety decals and instructions are easily visible to the operator and are located near any area of potential danger. Replace any decal that is damaged or lost.

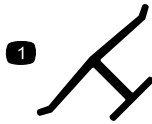

**Manufacturer's Mark**

1. Indicates the blade is identified as a part from the original machine manufacturer.



94-8072



116-7583

1. Warning—Read the *Operator's Manual*. Do not operate this machine unless you are trained.
2. Thrown object hazard—keep bystanders a safe distance from the machine.
3. Thrown object hazard—Do not operate the mower without the rear discharge plug or bag in place.
4. Cutting/dismemberment hazard of hand or foot, mower blade—stay away from moving parts; keep all guards in place.
5. Warning—wear hearing protection.
6. Cutting/dismemberment hazard of hand or foot, mower blade—Do not operate up and down slopes; operate side to side on slopes; stop the engine before leaving the operating position—pick up objects that could be thrown by the blades; and look behind you when backing up.

### CALIFORNIA SPARK ARRESTER WARNING

Operation of this equipment may create sparks that can start fires around dry vegetation. A spark arrester may be required. The operator should contact local fire agencies for laws or regulations relating to fire prevention requirements. 117-2718

117-2718



125-8403

1. Push the primer once.
2. Pull the recoil-start handle.

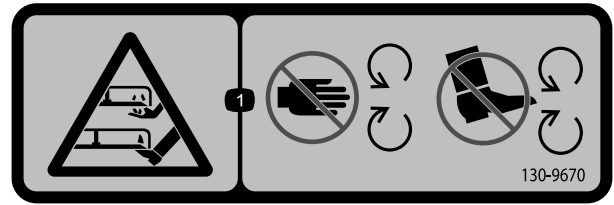

130-9670

1. Severing hazard of hand or foot; mower blade—keep away from moving parts; keep all guards and shields in place.

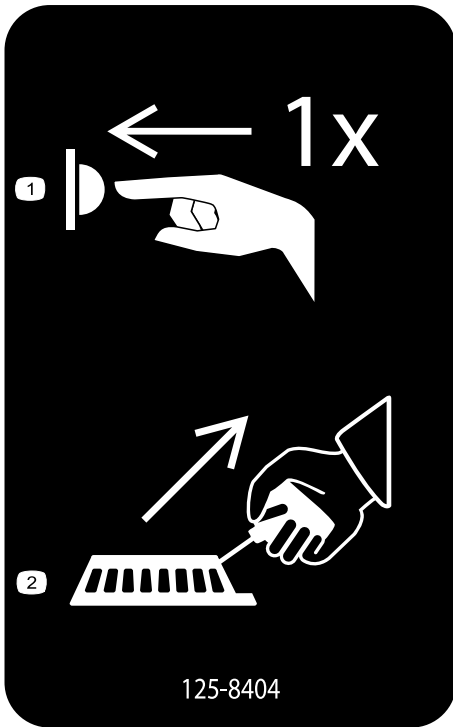

125-8404

1. Push the primer once.
2. Pull the recoil-start handle.

		130-6722
<p><b>AJUSTE DE LA TRANSMISIÓN AUTOPROPULSADA:</b>          No apretar demasiado para evitar un desgaste prematuro de la transmisión. Consultar las instrucciones de ajuste y seguridad del Manual del operador.</p>	<p><b>ADJUSTING THE SELF PROPEL DRIVE:</b>          Do not over-tighten or premature transmission wear may occur. Refer to operator's manual for adjustment and safety instructions.</p>	
<p><b>EINSTELLEN DES SELBSTANTRIEBS:</b>          Bitte beachten sie die Einstellungshinweise in der Bedienungsanleitung, durch falsche Justierung kann das Getriebe vorzeitig verschleiben.</p>	<p><b>RÉGLAGE DE L'AUTOTRACTION :</b>          Ne pas serrer excessivement, au risque d'entraîner une usure prématurée de la transmission. Se reporter au manuel de l'utilisateur pour connaître les instructions de réglage et de sécurité.</p>	

130-6722

1. Attention—read the *Operator's Manual*.

# Setup

## Loose Parts

Use the chart below to verify that all parts have been shipped.

Procedure	Description	Qty.	Use
<b>1</b>	Handle	1	Install the handle.
	Hex-head-flange bolt (5/16 x 1-1/2 inches)	2	
	Carriage bolt (5/16 x 1-1/2 inches)	2	
	Flange nut (5/16 inch)	4	
<b>2</b>	No parts required	–	Install the starter rope.
<b>3</b>	No parts required	–	Fill the crankcase with oil.
<b>4</b>	No parts required	–	Adjust the self-propel drive.
<b>5</b>	No parts required	–	Assemble the grass bag.

**Note:** Determine the left and right sides of the machine from the normal operating position.

# 1

## Installing the Handle

### Parts needed for this procedure:

1	Handle
2	Hex-head-flange bolt (5/16 x 1-1/2 inches)
2	Carriage bolt (5/16 x 1-1/2 inches)
4	Flange nut (5/16 inch)

### Procedure

1. Remove the cable guard from the handle (Figure 3) by removing the 2 carriage bolts and 2 locknuts that hold the cable guard to the handle.

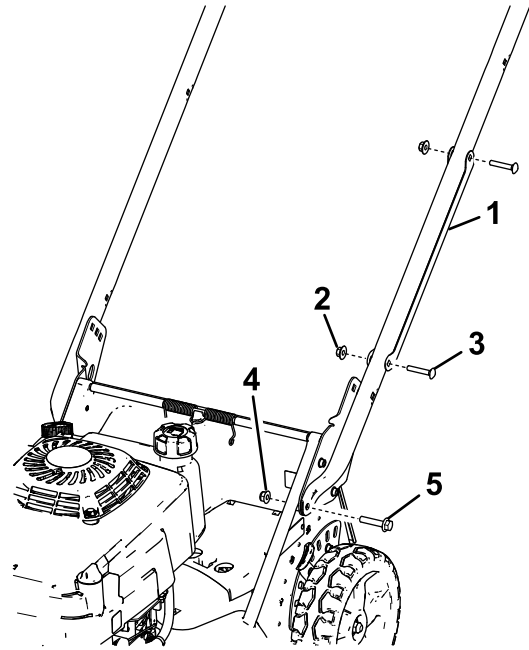
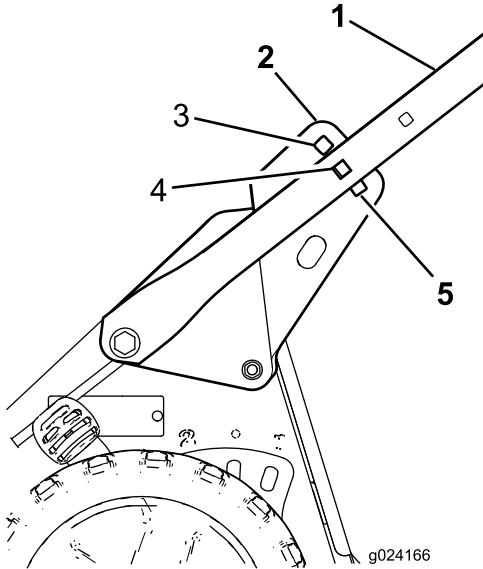

**Figure 3**

- |   |   |
|---|---|
| 1. Cable guard                          | 4. Flange nut—5/16 inch (2)                     |
| 2. Locknut (2)                          | 5. Hex-head-flange bolt—5/16 x 1-1/2 inches (2) |
| 3. Carriage bolt—1/4 x 1-1/2 inches (2) |   |

**Note:** Save the guard, the carriage bolts, and the locknuts so that you can install it onto the handle later in this procedure.

2. Install the handle ends onto the mower housing with 2 hex-head-flange bolts (5/16 x 1-1/2 inches) and 2 flange nuts (5/16 inch) as shown in [Figure 3](#).
3. Set the machine to the desired cutting height; refer to [Adjusting the Cutting Height \(page 12\)](#).
4. Stand behind the machine in the operating position to determine the handle height that is most comfortable for you ([Figure 4](#)).



**Figure 4**

- |                          |                         |
|--------------------------|-------------------------|
| 1. Handle                | 4. Medium handle height |
| 2. Handle bracket (2)    | 5. Lowest handle height |
| 3. Highest handle height |                         |

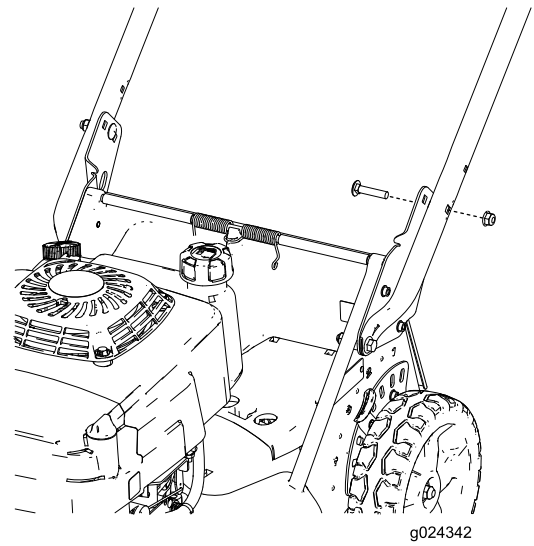

**Figure 5**

- |  |                             |
|--|-----------------------------|
| 1. Carriage bolt—5/16 x 1-1/2 inches (2) | 3. Flange nut—5/16 inch (2) |
| 2. Handle bracket (2)                    |                             |

6. Position the cable guard onto the handle with the cable(s) inside the guard, and secure the guard to the handle with the 2 carriage bolts and the 2 locknuts that you previously removed ([Figure 3](#)).

**Important:** Ensure that you do not pinch the cable(s) to the handle with when you install the cable guards onto the handle.

5. Secure the handle onto the handle brackets at your desired handle height with 2 carriage bolts (5/16 x 1-1/2 inches) and 2 flange nuts (5/16 inch) as shown in [Figure 5](#).

**Important:** Ensure that the bolt heads are on the inside of the handle and the nuts are on the outside of the handle.



# 2

## Installing the Recoil-Start Rope

### No Parts Required

### Procedure

Pull the recoil-start rope through the rope guide on the handle (Figure 6).

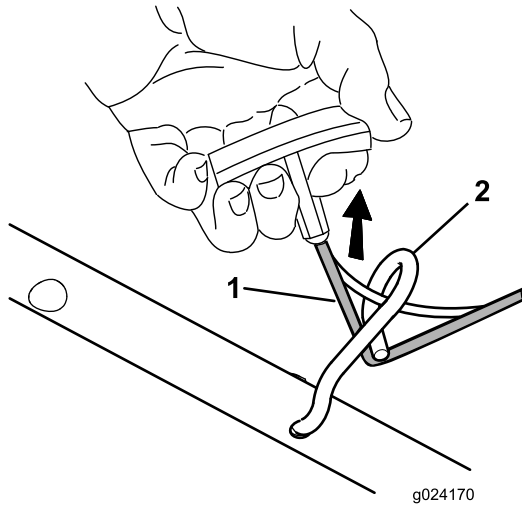

Figure 6

1. Recoil-start rope
2. Rope guide

**Note:** To make the rope easier to install, squeeze the blade-control bar on the handle.

# 3

## Filling the Crankcase with Oil

### No Parts Required

### Procedure

The engine crankcase is shipped without oil. Before starting the engine, fill the crankcase with oil. The engine crankcase (with oil filter) can hold 0.65 L (22 oz) of oil. Use only high-quality SAE 10W-30 weight detergent oil that has the American Petroleum Institute (API) service classification SH, SJ, or equivalent.

Before each use, ensure that the oil level is between the Add and the Full marks on the dipstick (Figure 7).

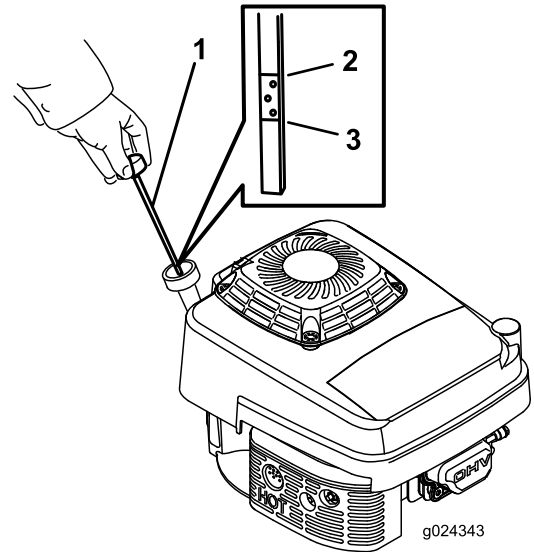

Figure 7

1. Dipstick
2. Full mark
3. Add mark

**Note:** When the crankcase is empty, pour about 3/4 of the crankcase capacity of oil in the crankcase, then follow the procedure in this section.

1. Move the machine onto a level surface.
2. Clean around the dipstick (Figure 7).
3. Remove the dipstick by rotating the cap counterclockwise and pulling it out.
4. Wipe the dipstick clean with a clean cloth.
5. Insert the dipstick into the filler neck, then remove the dipstick.
6. Read the oil level on the dipstick.
  - If the oil level is below the Add mark on the dipstick, slowly pour a small amount of oil into the oil-fill tube, wait 3 minutes, and repeat steps 4

through 6 until the oil level is at the Full mark on the dipstick.

- If the oil level is above the Full mark on the dipstick, drain the excess oil until the oil level on the dipstick is at the Full mark. Refer to [Changing the Engine Oil \(page 17\)](#).

**Important:** If the oil level in the crankcase is too low or too high and you run the engine, you may damage the engine.

7. Insert the dipstick into the filler neck and rotate the cap clockwise until it is tight.

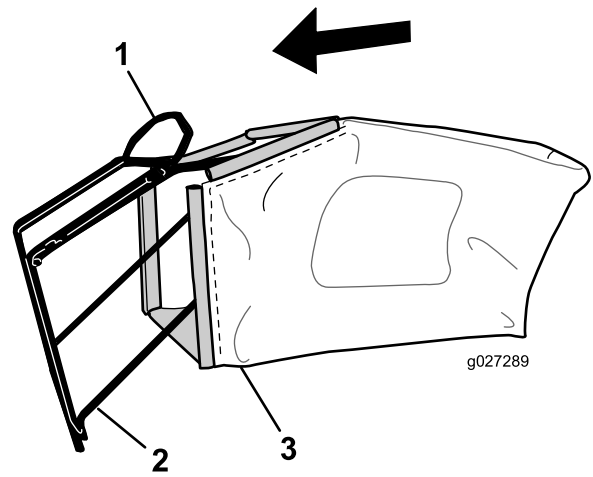

Figure 8

1. Handle
2. Frame
3. Grass bag

**Note:** Do not slip the bag over the handle ([Figure 8](#)).

2. Hook the bottom channel of the bag onto the bottom of the frame ([Figure 9](#)).

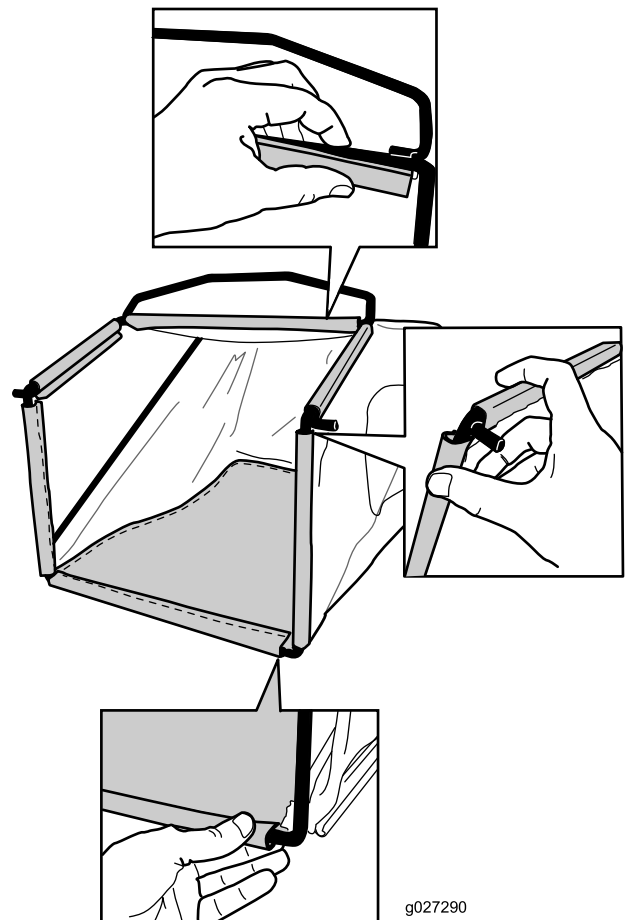

Figure 9

3. Hook the top and side channels of the bag onto the top and sides of the frame, respectively ([Figure 9](#)).

## 4

### Adjusting the Self-Propel Drive

#### No Parts Required

#### Procedure

**Important:** You must adjust the self-propel-drive cable before you operate the machine for the first time. Refer to [Adjusting the Self-Propel Drive \(page 18\)](#).

## 5

### Assembling the Grass Bag

#### No Parts Required

#### Procedure

1. Slip the grass bag over the frame as shown in [Figure 8](#).

# Product Overview

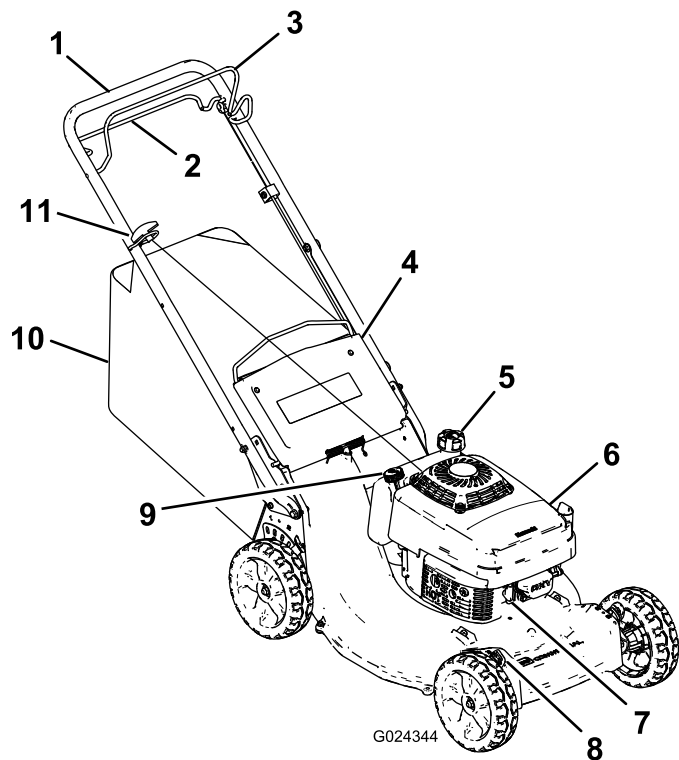

**Figure 10**

- |                          |                             |
|--------------------------|-----------------------------|
| 1. Handle                | 7. Spark plug               |
| 2. Self-propel-drive bar | 8. Cutting-height lever (4) |
| 3. Blade-control bar     | 9. Oil fill/dipstick        |
| 4. Rear door             | 10. Grass bag               |
| 5. Fuel-tank cap         | 11. Recoil-start handle     |
| 6. Air cleaner           |                             |

# Operation

**Note:** Determine the left and right sides of the machine from the normal operating position.

Each time before you mow, ensure that the self-propel drive and the blade-control bar operate properly. When you release the blade-control bar, the blade and the self-propel drive should stop. If they do not, contact an Authorized Service Dealer.

## **⚠ CAUTION**

This machine produces sound levels in excess of 85dBA at the operator's ear and can cause hearing loss through extended periods of exposure.

Wear hearing protection when operating this machine.



**Figure 11**

1. Warning—wear hearing protection.

# Checking the Engine-Oil Level

**Service Interval:** Before each use or daily—Check the engine-oil level.

Before you use the machine, ensure that the oil level is between the Add and the Full marks as shown on the dipstick (Figure 12).

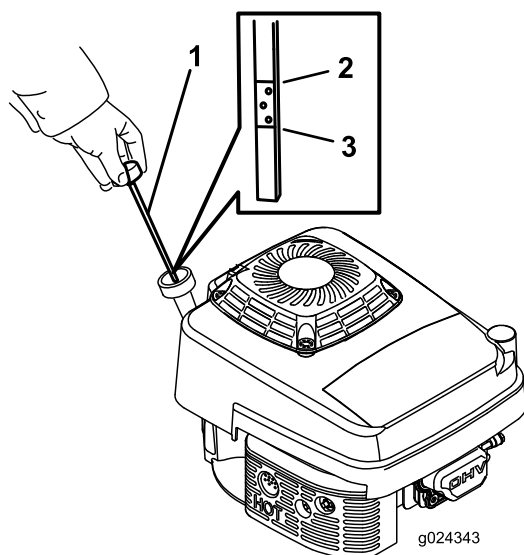

Figure 12

1. Dipstick
2. Full mark
3. Add mark

If the oil level is below the Add mark, add oil. Refer to [3 Filling the Crankcase with Oil \(page 9\)](#).

## Filling the Fuel Tank with Gasoline

### ⚠ DANGER

Gasoline is extremely flammable and explosive. A fire or explosion from gasoline can burn you and others.

- To prevent a static charge from igniting the gasoline, place the container and/or machine directly on the ground before filling, not in a vehicle or on an object.
- Fill the tank outdoors when the engine is cold. Wipe up spills.
- Do not handle gasoline when smoking or around an open flame or sparks.
- Store gasoline in an approved fuel container, out of the reach of children.
- For best results, use only clean, fresh (less than 30 days old), unleaded gasoline with an octane rating of 87 or higher ((R+M)/2 rating method).

- Oxygenated fuel with up to 10% ethanol or 15% MTBE by volume is acceptable.
- **Ethanol:** Gasoline with up to 10% ethanol (gasohol) or 15% MTBE (methyl tertiary butyl ether) by volume is acceptable. Ethanol and MTBE are not the same. Gasoline with 15% ethanol (E15) by volume is not approved for use. **Never use gasoline that contains more than 10% ethanol by volume**, such as E15 (contains 15% ethanol), E20 (contains 20% ethanol), or E85 (contains up to 85% ethanol). Using unapproved gasoline may cause performance problems and/or engine damage which may not be covered under warranty.
- Do not use gasoline containing methanol.
- Do not store fuel either in the fuel tank or in fuel containers over the winter unless a fuel stabilizer is used.
- Do not add oil to gasoline.

**Important:** To reduce starting problems, add fuel stabilizer to the fuel all season, mixing it with gasoline less than 30 days old.

**Note:** The capacity of the fuel tank is 1.8 L (0.47 US gallon).

## Adjusting the Cutting Height

You can change the cutting height at each wheel by adjusting a cutting-height lever. Cutting heights are 25 mm (1 inch), 38 mm (1-1/2 inches), 51 mm (2 inches), 64 mm (2-1/2 inches), 76 mm (3 inches), 89 mm (3-1/2 inches), 102 mm (4 inches), 114 mm (4-1/2 inches).

### ⚠ DANGER

Adjusting the cutting-height levers could bring your hands into contact with a moving blade and result in serious injury.

- Stop the engine and wait for all movement to stop before adjusting the cutting height.
  - Do not put your fingers under the housing when adjusting the cutting height.
1. Pull the cutting-height lever toward the wheel (Figure 13) and move the lever to the desired setting.

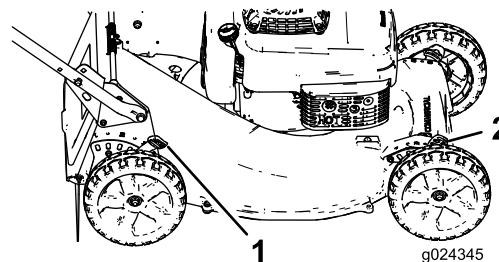

Figure 13

1. Rear cutting-height lever (2)
2. Front cutting-height lever (2)

2. Release the cutting-height lever and seat it securely in the notch.
3. Adjust all the wheels to the same cutting-height setting.

## Starting the Engine

1. Connect the spark-plug wire to the spark plug.
2. Firmly push in the primer (Figure 14), holding the primer bulb in for 1 second.

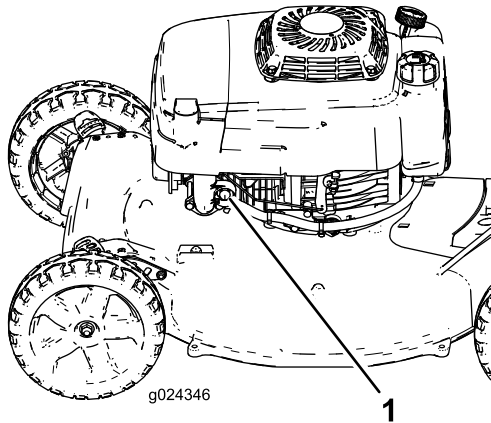

Figure 14

1. Primer

3. Hold the blade-control bar against the upper handle (Figure 15).

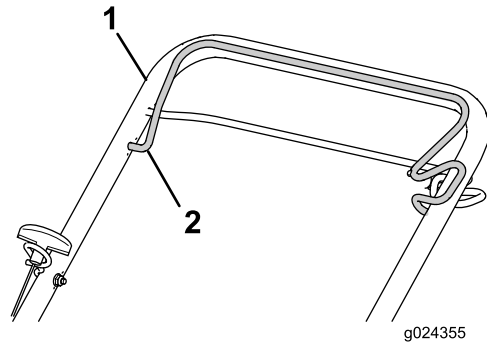

Figure 15

1. Upper handle
2. Blade-control bar

4. Pull the starter handle lightly until you feel resistance, pull it sharply, then allow it to return slowly to the rope guide on the handle.

**Note:** If the engine does not start, repeat steps 2 through 4.

## Stopping the Engine

Release the blade-control bar. Both the engine and the blade should stop within 3 seconds. If they do not, contact an Authorized Service Dealer.

## Operating the Self-Propel Drive

- **To engage the self-propel-drive:** Squeeze the self-propel-drive bar against the handle and hold it (Figure 16).

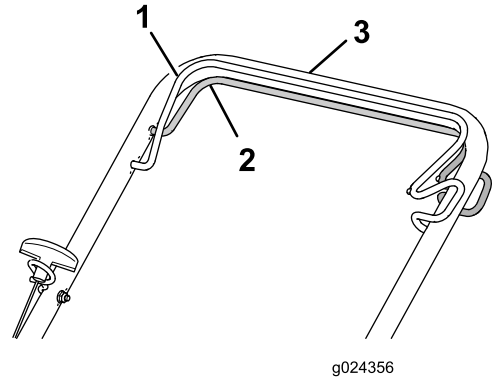

Figure 16

1. Blade-control bar (shown engaged)
2. Self-propel-drive bar
3. Upper handle engaged

**Note:** The maximum self-propel-drive speed is fixed. To reduce the speed, increase the space between the self-propel-drive bar and the handle.

- **To disengage the self-propel drive:** Release the self-propel-drive bar.

**Note:** The machine comes with freewheeling clutches that make it easier to pull the machine rearward. To disengage the clutches, you may need to push the machine forward about 2.5 cm (1 inch) or more after you release the self-propel-drive bar.

## Recycling the Clippings

This machine comes from the factory ready to recycle grass and leaf clippings back into the lawn. To prepare the machine to recycle:

- If the grass bag is on the machine, remove it; refer to [Removing the Grass Bag \(page 14\)](#).
- If the rear-discharge plug is not installed, grip it by the handle, raise the rear door, and insert it into the rear-discharge chute until the latch locks into place (Figure 17).

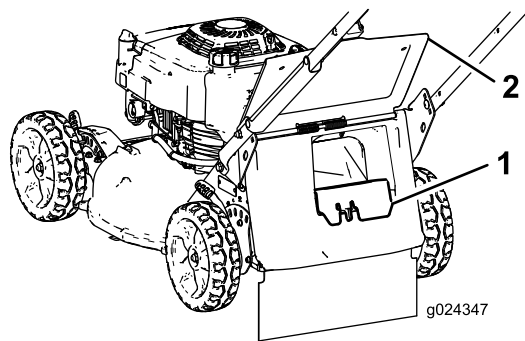

Figure 17

1. Rear-discharge plug
2. Rear door

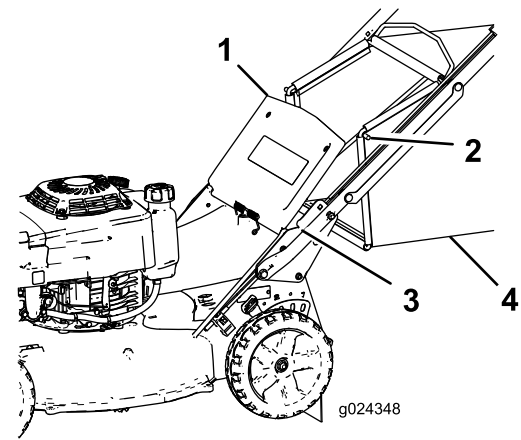

Figure 18

1. Rear door
2. Bag-rod end (2)
3. Notch (2)
4. Grass bag

## ⚠ WARNING

Operating the machine to recycle lawn clippings without the plug in place allows objects to be thrown in your direction or in the direction of bystanders. Also, contact with the blades could occur. Thrown objects or blade contact can cause serious injury or death.

Ensure that the rear-discharge plug is in place before you recycle the clippings. Never engage the blades without either the rear-discharge plug or the grass bag installed on the machine.

## Bagging the Clippings

Use the grass bag when you want to collect grass and leaf clippings from the lawn.

## ⚠ WARNING

A worn grass bag could allow small stones and other similar debris to be thrown toward you or bystanders, resulting in serious personal injury or death.

Check the grass bag frequently. If it is damaged, install a new Toro replacement bag.

## ⚠ WARNING

The blades are sharp; contacting the blades can result in serious personal injury.

Stop the engine and wait for all moving parts to stop before leaving the operating position.

## Installing the Grass Bag

1. Stop the engine and wait for all moving parts to stop.
2. Raise and hold up the rear door (Figure 18).

3. Remove the rear-discharge plug by pushing in the latch with your thumb and pulling the plug out from the machine (Figure 17).
4. Install the bag-rod ends into the notches at the base of the handle, and rock the bag back and forth to ensure that the bag-rod ends are seated at the bottom of both notches (Figure 18).
5. Lower the rear door until it rests on the grass bag.

## Removing the Grass Bag

## ⚠ DANGER

The machine can throw grass clippings and other objects through an opening in the mower housing. Objects thrown with enough force could cause serious personal injury or death to you or to bystanders.

- Never remove the grass bag and then start the engine without the discharge plug installed on the machine.
  - Never open the rear door on the machine when the engine is running.
1. Stop the engine and wait for all moving parts to stop.
  2. Raise the rear door.
  3. Remove the bag rod on the grass bag from the notches at the base of the handle (Figure 18).
  4. Install the discharge plug; refer to [Recycling the Clippings](#) (page 13).
  5. Lower the rear door.



# Operating Tips

## General Tips

- Review the safety instructions and read this manual carefully before operating the machine.
- Clear the area of sticks, stones, wire, branches, and other debris that the blade could hit and throw.
- Keep everyone, especially children and pets, away from the area of operation.
- Avoid striking trees, walls, curbs, or other solid objects. Never deliberately mow over any object.
- If the machine strikes an object or starts to vibrate, immediately stop the engine, disconnect the wire from the spark plug, and examine the machine for damage.
- Maintain a **sharp blade** throughout the cutting season. Periodically file down nicks on the blade.
- Replace the blade when necessary with an original Toro replacement blade.
- Mow only dry grass or leaves. Wet grass and leaves tend to clump on the yard and can cause the machine to plug or the engine to stall.

### **⚠ WARNING**

**Wet grass or leaves can cause serious injury if you slip and contact the blade.**

**Mow only in dry conditions.**

- Clean under the machine after each mowing; refer to [Cleaning under the Machine \(page 21\)](#).
- Keep the engine in good running condition.
- Clean the air filter frequently. Mulching stirs up more clippings and dust which clogs the air filter and reduces engine performance.
- Set the engine speed to the fastest position for the best cutting results.

### **⚠ WARNING**

**Operating a machine with its engine running at a speed greater than the factory setting can cause the machine to throw a part of the blade or engine at you or bystanders, resulting in serious personal injury or death.**

- **Do not change the engine speed setting.**
- **If you suspect the engine speed is faster than normal, contact an Authorized Service Dealer.**

## Cutting Grass

- Grass grows at different rates at different times of the year. In the summer heat, it is best to cut grass at the 64

mm (2-1/2 inch), 76 mm (3 inch), or 89 mm (3-1/2 inch) cutting-height settings. Cut only about a third of the grass blade at a time. Do not cut below the 64 mm (2-1/2 inch) setting unless the grass is sparse or it is late fall when grass growth begins to slow down.

- When cutting grass over 15 cm (6 inches) tall, first mow at the highest cutting height setting and walk slower; then mow again at a lower setting for the best lawn appearance. If the grass is too long and the leaves clump on top of the lawn, the machine may plug and cause the engine to stall.
- Alternate the mowing direction. This helps disperse the clippings over the lawn for even fertilization.

If the finished lawn appearance is unsatisfactory, try 1 or more of the following:

- Sharpen the blade.
- Walk at a slower pace while mowing.
- Raise the cutting height on your machine.
- Cut the grass more frequently.
- Overlap cutting swaths instead of cutting a full swath with each pass.
- Set the cutting height on the front wheels a notch lower than the rear wheels. For example, set the front wheels at 64 mm (2-1/2 inches) and the rear wheels at 76 mm (3 inches).

## Cutting Leaves

- After cutting the lawn, ensure that half of the lawn shows through the cut leaf cover. You may need to make more than a single pass over the leaves.
- For light leaf coverage, set all the wheels at the same cutting height setting.
- If there are more than 13 cm (5 inches) of leaves on the lawn, set the front cutting height 1 or 2 notches higher than the rear cutting height. This makes it easier to feed the leaves under the machine.
- Slow down your mowing speed if the machine does not cut the leaves finely enough.

# Maintenance

**Note:** Determine the left and right sides of the machine from the normal operating position.

## Recommended Maintenance Schedule(s)

Maintenance Service Interval	Maintenance Procedure
After the first 8 hours	<ul style="list-style-type: none"><li>• Change the engine oil.</li></ul>
After the first 25 hours	<ul style="list-style-type: none"><li>• Tighten any loose fasteners.</li></ul>
Before each use or daily	<ul style="list-style-type: none"><li>• Check the engine-oil level.</li><li>• Inspect the mower blades for wear or damage.</li><li>• Inspect the accelerator for wear or damage.</li><li>• Remove grass clippings and dirt from under the machine.</li><li>• Check the stopping time of the blade brake. The blade must stop within 3 seconds of releasing the blade-control bar; if it does not, contact an Authorized Service Dealer for repair.</li><li>• Check for loose or missing fasteners on the engine.</li><li>• Check for fuel or oil leaks.</li><li>• Check or clean the recoil starter and the air-intake screen.</li></ul>
Every 25 hours	<ul style="list-style-type: none"><li>• Clean the foam pre-cleaner (more frequently in dusty conditions).</li></ul>
Every 50 hours	<ul style="list-style-type: none"><li>• Change the engine oil (more frequently in dusty conditions).</li><li>• Sharpen or replace the blade. Maintain it more frequently if the edge dulls quickly in rough or in sandy conditions.</li></ul>
Every 100 hours	<ul style="list-style-type: none"><li>• Inspect, clean, and adjust the spark plug gap; replace the spark plug if necessary.</li><li>• Tighten any loose fasteners.</li><li>• Check or clean the recoil starter and the air-intake screen.</li></ul>
Every 200 hours	<ul style="list-style-type: none"><li>• Have an authorized engine servicing dealer check for leaks in the fuel system and/or a deteriorating fuel hose. Replace parts if necessary.</li></ul>
Every 300 hours	<ul style="list-style-type: none"><li>• Replace the paper air filter (more frequently in dusty conditions).</li><li>• Clean the cylinder and the cylinder-head fins.</li><li>• Have an authorized engine servicing dealer check and adjust the engine idle speed.</li><li>• Have an authorized engine servicing dealer clean the combustion chamber.</li><li>• Have an authorized engine servicing dealer check and adjust the valve clearance.</li><li>• Have an authorized engine servicing dealer clean and lap the valve seating surface.</li></ul>

**Important:** Refer to your engine owner's manual for additional maintenance procedures.

### **▲ CAUTION**

If you leave the wire on the spark plug, someone could accidentally start the engine and seriously injure you or bystanders.

Disconnect the wire from the spark plug before you do any maintenance. Set the wire aside so that it does not accidentally contact the spark plug.



# Engine Maintenance

## Servicing the Air Cleaner

**Service Interval:** Every 25 hours—Clean the foam pre-cleaner (more frequently in dusty conditions).

Every 300 hours—Replace the paper air filter (more frequently in dusty conditions).

**Important:** Do not operate the engine without the air filter assembly in place; otherwise, extreme engine damage will occur.

1. Stop the engine and wait for all moving parts to stop.
2. Disconnect the wire from the spark plug.
3. Loosen the screw on the air-cleaner cover (Figure 19).

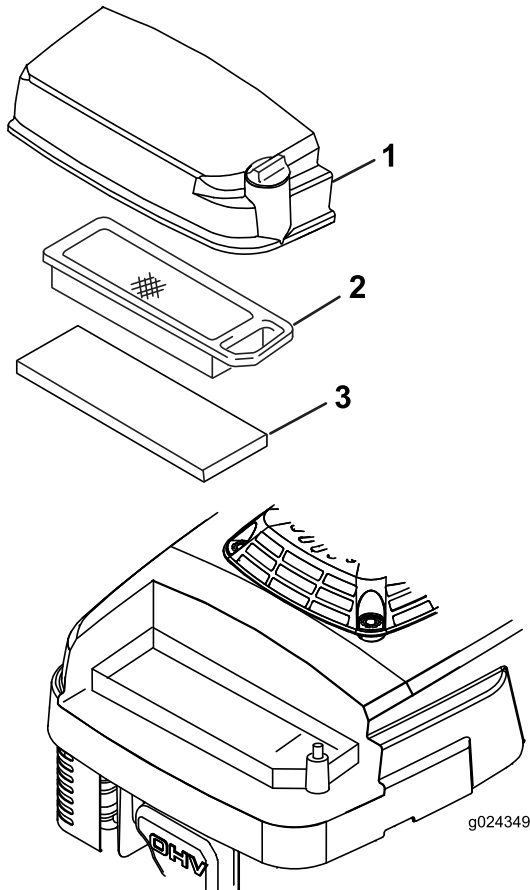

Figure 19

1. Air-cleaner cover
2. Paper air filter
3. Foam pre-cleaner

4. Remove the cover and clean it thoroughly.
5. Remove and inspect the paper air filter (Figure 19), and replace it if it is excessively dirty.

**Important:** Do not try to clean a paper filter.

6. Remove the foam pre-cleaner (Figure 19) and wash it with a mild detergent and water, then blot it dry.

7. Install the foam pre-cleaner.
8. Install the paper air filter.
9. Install the cover and secure it with the screw.

## Changing the Engine Oil

**Service Interval:** After the first 8 hours

Every 50 hours

1. Run the engine to warm the engine oil.

**Note:** Warm oil flows better and carries more contaminants.

### ⚠ WARNING

**Oil may be hot after engine has been run, and contact with hot oil can cause severe personal injury.**

**Avoid contacting the hot engine oil when you drain it.**

2. Stop the engine and wait for all moving parts to stop.
3. Disconnect the wire from the spark plug.
4. Drain the gasoline from the fuel tank.
5. Place a suitable drain pan under the dipstick/oil drain.
6. Clean around the dipstick.
7. Remove the dipstick by rotating the cap counterclockwise and pulling it out.
8. Tip the machine onto its **right** side (air filter up) to drain the oil into the drain pan.
9. After draining the oil, return the machine to the operating position.
10. Fill the crankcase to the Full mark on the dipstick with fresh oil; refer to [3 Filling the Crankcase with Oil \(page 9\)](#).
11. Insert the dipstick into the filler neck and rotate the cap clockwise until it is tight.
12. Wipe up any spilled oil.
13. Recycle the used oil according to local codes.

# Servicing the Spark Plug

**Service Interval:** Every 100 hours—Inspect, clean, and adjust the spark plug gap; replace the spark plug if necessary.

Use an **NGK BPR5ES** spark plug or equivalent.

1. Stop the engine and wait for all moving parts to stop.
2. Disconnect the wire from the spark plug.
3. Clean around the spark plug.
4. Remove the spark plug from the cylinder head.

**Important:** Replace a cracked, fouled, or dirty spark plug. Do not clean the electrodes because grit entering the cylinder can damage the engine.

5. Set the gap on the plug to 0.76 mm (0.030 inch); refer to [Figure 20](#).

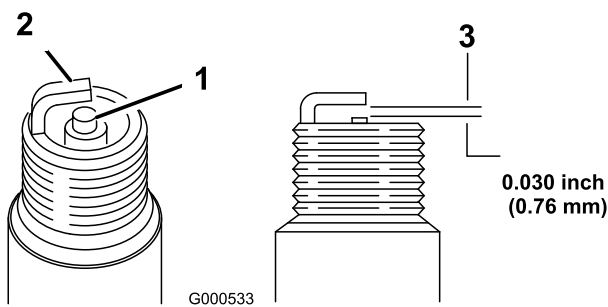

**Figure 20**

1. Center-electrode insulator
2. Side electrode
3. Air gap (not to scale)

6. Carefully install the spark plug by hand (to avoid cross threading) until it is hand tight.
7. Tighten the spark plug to 23 N-m (2.3 kgf-m, 17 ft-lb).

**Important:** A loose spark plug can become very hot and can damage the engine; overtightening a spark plug may damage the threads in the cylinder head.

8. Connect the wire to the spark plug.

# Drive System Maintenance

## Adjusting the Self-Propel Drive

**Note:** If the machine is new, does not self-propel, or tends to creep forward, adjust the drive cable.

1. Move the machine outside and onto a paved surface near a solid wall to safely prevent the machine from moving forward while the engine is running.
2. Position the machine with the front tires against the wall.

**Note:** Ensure that the area is well ventilated and clear of debris that could be thrown by the machine.

3. Start the engine; refer to [Starting the Engine](#) (page 13).
4. Pull the self-propel-drive bar to the handle.

**Note:** The wheels should start to turn as the self-propel-drive bar just touches the handle.

5. Shut off the engine.
6. If you must adjust the machine, do one of the following:
  - If the wheels do not spin when you engage the self-propel-drive bar, the traction belt is too loose. Rotate the wheel-drive-control knob ([Figure 21](#)) clockwise 1 turn and repeat steps 3 through 5.

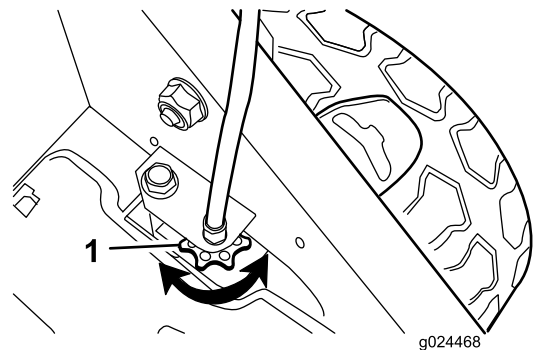

**Figure 21**

1. Wheel-drive-control knob

- If the wheels spin before you fully engage the self-propel-drive bar, the traction belt is too tight. Rotate the wheel-drive-control knob ([Figure 21](#)) counterclockwise 1 turn and repeat steps 3 through 5.

7. For a new traction belt, rotate the wheel-drive-control knob clockwise 1 additional turn to allow for stretching of the belt during the break-in period.

**Note:** You can skip this step if you are adjusting a used belt.

# Blade Maintenance

## Maintaining the Blade

Always mow with a sharp blade. A sharp blade cuts cleanly and without tearing or shredding the grass blades.

1. Stop the engine and wait for all moving parts to stop.
2. Disconnect the wire from the spark plug.
3. Drain the gasoline from the fuel tank.
4. Tip the machine onto its **right** side (air cleaner up) as shown in [Figure 22](#).

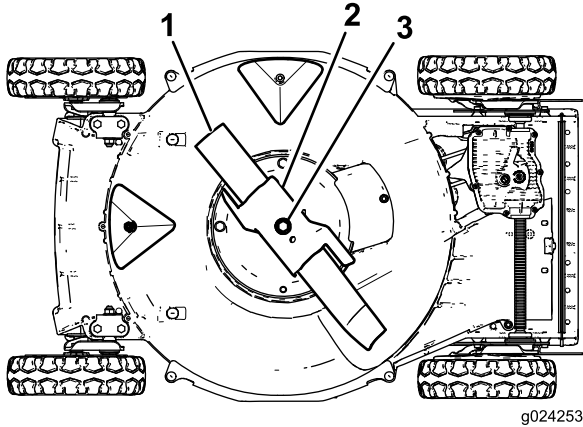

Figure 22

1. Blade
2. Accelerator
3. Blade bolt and lock washer

## Inspecting the Blade

**Service Interval:** Before each use or daily—Inspect the mower blades for wear or damage.

Carefully examine the blade for sharpness and wear, especially where the flat and the curved parts meet ([Figure 23A](#)). Because sand and abrasive material can wear away the metal that connects the flat and curved parts of the blade, check the blade before using the machine. If you notice a slot or wear ([Figure 23B](#) and [Figure 23C](#)), replace the blade; refer to [Removing the Blade](#) (page 20).

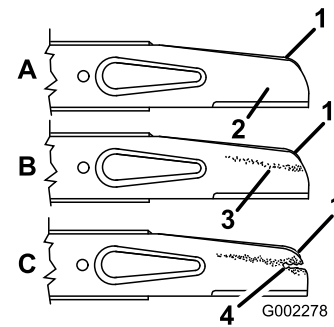

Figure 23

1. Sail
2. Flat part of the blade
3. Wear
4. Slot formed

**Note:** For the best performance, install a new blade before the mowing season begins. During the year, file down any small nicks to maintain the cutting edge.

## **▲ DANGER**

A worn or damaged blade can break, and a piece of the blade could be thrown in your direction or in the direction of bystanders, resulting in serious personal injury or death.

- Inspect the blade periodically for wear or damage.
- Replace a worn or damaged blade.

## Inspecting the Accelerator

**Service Interval:** Before each use or daily—Inspect the accelerator for wear or damage.

Carefully examine the accelerator for excessive wear ([Figure 24](#)). Because sand and abrasive material can wear away the metal (especially in the area shown as item 2 in [Figure 24](#)), check the accelerator before using the machine. If you notice that a tab on the accelerator has been worn down to a sharp edge or there is a crack, replace the accelerator; refer to [Removing the Blade](#) (page 20).

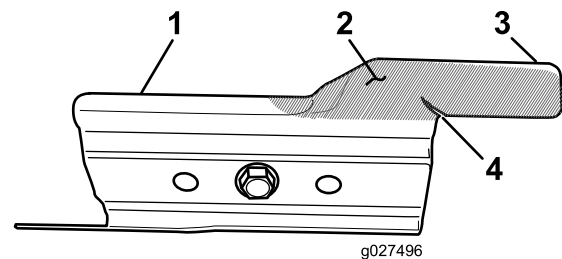

Figure 24

1. Accelerator
2. Wear area
3. Tab
4. Crack formed

## ⚠ WARNING

A worn or damaged accelerator can break, and a piece of the accelerator could be thrown at you or bystanders, resulting in serious personal injury or death.

- Inspect the accelerator periodically for wear or damage.
- Replace a worn or damaged accelerator.

## Removing the Blade

1. Grasp the end of the blade using a rag or a thickly padded glove.
2. Remove the blade bolt, the lock washer, the accelerator, and the blade (Figure 23).

## Sharpening the Blade

**Service Interval:** Every 50 hours—Sharpen or replace the blade. Maintain it more frequently if the edge dulls quickly in rough or in sandy conditions.

File the top side of the blade to maintain its original cutting angle (Figure 25A) and inner cutting edge radius (Figure 25B). The blade will remain balanced if you remove the same amount of material from both cutting edges.

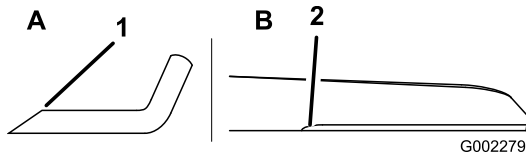

Figure 25

1. Sharpen the blade at this angle only.
2. Maintain the original radius here.

## Balancing the Blade

1. Check the balance of the blade by placing the center hole of the blade over a nail or screwdriver shank clamped horizontally in a vise (Figure 26).

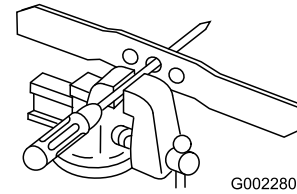

Figure 26

**Note:** You can also check the balance using a commercially manufactured blade balancer.

2. If either end of the blade rotates downward, file that end (not the cutting edge or the end near the cutting edge) until neither end of the blade drops.

## Installing the Blade

1. Install a sharp, balanced Toro blade, the accelerator, the lock washer, and the blade bolt. The sail of the blade must point toward the top of the mower housing for proper installation.

**Note:** Torque the blade bolt to 68 N-m (50 ft-lb).

## ⚠ WARNING

Operating the machine without the accelerator in place can cause the blade to flex, bend, or break, resulting in serious injury or death to you or to bystanders.

**Do not operate the machine without the accelerator in place.**

2. Return the machine to the operating position.

# Cleaning

## Cleaning under the Machine

To ensure the best performance, keep the underside of the machine clean. Be especially careful to keep the kickers free of debris (Figure 27).

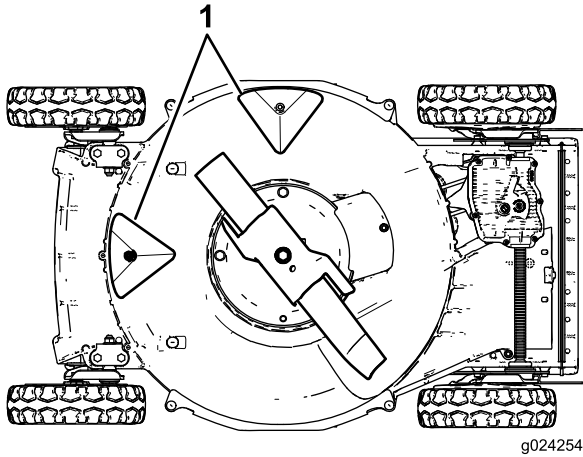

Figure 27

1. Kickers

## Washing Method

**Service Interval:** Before each use or daily

### **⚠ WARNING**

The machine may dislodge material from under the machine.

- Wear eye protection.
  - Stay in the operating position (behind the handle) while the engine is running.
  - Do not allow bystanders in the area.
1. Position the machine on a flat concrete or asphalt surface near a garden hose.
  2. Start the engine.
  3. Hold the running garden hose at handle level and direct the water to flow on the ground just in front of the right rear tire (Figure 28).

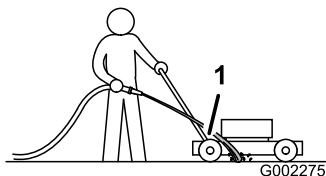

Figure 28

1. Right rear wheel

**Note:** The blade will draw in water and wash out the clippings. Let the water run until you no longer see clippings being washed out from under the machine.

4. Stop the engine and wait for all moving parts to stop.
5. Turn off the water.
6. Start the machine and let it run for a few minutes to dry out the underside of the machine.

## Scraping Method

If washing does not remove all debris from under the machine, scrape it clean.

1. Disconnect the wire from the spark plug.
2. Drain the gasoline from the fuel tank.

### **⚠ WARNING**

Tipping the machine may cause the gasoline to leak from the carburetor or the fuel tank. Gasoline is extremely flammable, highly explosive, and, under certain conditions, can cause personal injury or property damage.

Avoid fuel spills by running the engine dry or by removing the gasoline with a hand pump; never siphon.

3. Tip the machine onto its **right** side (air cleaner up).
4. Remove the dirt and grass clippings with a hardwood scraper. Avoid burrs and sharp edges.
5. Return the machine to the operating position.
6. Connect the wire to the spark plug.

# Storage

To prepare the machine for off-season storage, perform the recommended maintenance procedures; refer to [Maintenance \(page 16\)](#).

Store the machine in a cool, clean, dry place. Cover the machine to keep it clean and protected.

## Preparing the Fuel System

### **▲ WARNING**

Gasoline can vaporize if you store it over long periods of time and explode if it comes into contact with an open flame.

- **Do not store gasoline over long periods of time.**
- **Do not store the machine with gasoline in the fuel tank or the carburetor in an enclosure with an open flame. (For example, a furnace or a water heater pilot light.)**
- **Allow the engine to cool before storing it in any enclosure.**

Empty the gasoline from the fuel tank when mowing for the last time before storing the machine.

1. Run the engine until it stops from running out of gasoline.
2. Choke the engine and start it again.
3. Allow the engine to run until it stops. When you can no longer start the engine, it is sufficiently dry.

## Preparing the Engine

1. While the engine is still warm, change the oil in the crankcase; refer to [Changing the Engine Oil \(page 17\)](#).
2. Remove the spark plug.
3. Using an oil can, add about 30 ml (1 oz) of engine oil to the engine crankcase through the spark-plug hole.
4. Slowly rotate the engine several times by pulling the recoil-start handle to distribute the oil throughout the engine crankcase.
5. Install the spark plug but **do not** connect the wire to the spark plug.

## General Information

1. Clean under the machine; refer to [Cleaning under the Machine \(page 21\)](#).
2. Clean any dirt and chaff from the cylinder, cylinder head fins, and blower housing.

3. Remove grass clippings, dirt, and grime from the external parts of the engine, the shrouding, and the top of the mower housing.
4. Check the condition of the blade; refer to [Inspecting the Blade \(page 19\)](#).
5. Service the air cleaner; refer to [Servicing the Air Cleaner \(page 17\)](#).
6. Tighten all nuts, bolts, and screws.
7. Touch up all rusted or chipped paint surfaces with paint available from an Authorized Service Dealer.

## Removing the Machine from Storage

1. Check and tighten all fasteners.
2. Remove the spark plug and spin the engine rapidly using the starter to blow out the excess oil from the cylinder.
3. Clean the spark plug or replace it if it is cracked, broken, or if the electrodes are worn.
4. Install the spark plug; refer to [Servicing the Spark Plug \(page 18\)](#).
5. Perform any needed maintenance procedures; refer to [Maintenance \(page 16\)](#).
6. Fill the fuel in the fuel tank with fresh gasoline.
7. Check the engine-oil level.
8. Connect the wire to the spark plug.

# Troubleshooting

Problem	Possible Cause	Corrective Action
The engine does not start.	<ol style="list-style-type: none"> <li>1. The fuel tank is empty or the fuel system contains stale fuel.</li> <li>2. The throttle lever is not in the Choke position.</li> <li>3. The wire is not connected to the spark plug.</li> <li>4. The spark plug is pitted, fouled, or the gap is incorrect.</li> </ol>	<ol style="list-style-type: none"> <li>1. Drain and/or fill the fuel tank with fresh gasoline. If the problem persists, contact an Authorized Service Dealer.</li> <li>2. Move the throttle lever to the Choke position.</li> <li>3. Connect the wire to the spark plug.</li> <li>4. Check the spark plug and adjust the gap if necessary. Replace the spark plug if it is pitted, fouled, or cracked.</li> </ol>
The engine starts hard or loses power.	<ol style="list-style-type: none"> <li>1. The fuel tank contains stale fuel.</li> <li>2. The air filter element is dirty and is restricting the air flow.</li> <li>3. The underside of the mower housing contains clippings and debris.</li> <li>4. The spark plug is pitted, fouled, or the gap is incorrect.</li> <li>5. The engine oil level is low or the oil is dirty.</li> </ol>	<ol style="list-style-type: none"> <li>1. Drain and fill the fuel tank with fresh gasoline.</li> <li>2. Clean the air filter pre-cleaner and/or replace the paper air filter.</li> <li>3. Clean under the mower housing.</li> <li>4. Check the spark plug and adjust the gap if necessary. Replace the spark plug if it is pitted, fouled, or cracked.</li> <li>5. Check the engine oil. Change the oil if it is dirty or add oil if it is low.</li> </ol>
The engine runs rough.	<ol style="list-style-type: none"> <li>1. The wire is not connected to the spark plug.</li> <li>2. The spark plug is pitted, fouled, or the gap is incorrect.</li> <li>3. The throttle lever is not in the Fast position.</li> <li>4. The air filter element is dirty and is restricting the air flow.</li> </ol>	<ol style="list-style-type: none"> <li>1. Connect the wire to the spark plug.</li> <li>2. Check the spark plug and adjust the gap if necessary. Replace the spark plug if it is pitted, fouled, or cracked.</li> <li>3. Move the throttle lever to the Fast position.</li> <li>4. Clean the air filter pre-cleaner and/or replace the paper air filter.</li> </ol>
The machine or engine vibrates excessively.	<ol style="list-style-type: none"> <li>1. The blade is bent or is out of balance.</li> <li>2. The blade mounting nuts are loose.</li> <li>3. The underside of the machine contains clippings and debris.</li> <li>4. The engine mounting bolts are loose.</li> </ol>	<ol style="list-style-type: none"> <li>1. Balance the blade. If the blade is bent, replace it.</li> <li>2. Tighten the blade mounting nuts.</li> <li>3. Clean the underside of the machine.</li> <li>4. Tighten the engine mounting bolts.</li> </ol>
The is an uneven cutting pattern.	<ol style="list-style-type: none"> <li>1. All 4 wheels are not at the same height.</li> <li>2. The blade is dull.</li> <li>3. You are mowing in the same pattern repeatedly.</li> <li>4. The underside of the machine contains clippings and debris.</li> </ol>	<ol style="list-style-type: none"> <li>1. Place all 4 wheels at the same height.</li> <li>2. Sharpen and balance the blade.</li> <li>3. Change the mowing pattern.</li> <li>4. Clean the underside of the machine.</li> </ol>
The discharge chute plugs up.	<ol style="list-style-type: none"> <li>1. The throttle lever is not in the Fast position.</li> <li>2. The cutting height is too low.</li> <li>3. You are mowing too fast.</li> <li>4. The grass is wet.</li> <li>5. The underside of the machine contains clippings and debris.</li> </ol>	<ol style="list-style-type: none"> <li>1. Move the throttle lever to the Fast position.</li> <li>2. Raise the cutting height.</li> <li>3. Slow down.</li> <li>4. Allow the grass to dry before mowing.</li> <li>5. Clean the underside of the machine.</li> </ol>
The machine does not self-propel.	<ol style="list-style-type: none"> <li>1. The self-propel drive cable is out of adjustment or is damaged.</li> <li>2. There is debris under the belt cover.</li> </ol>	<ol style="list-style-type: none"> <li>1. Adjust the self-propel drive cable. Replace the cable if necessary.</li> <li>2. Clean the debris from under the belt cover.</li> </ol>





# The Toro Total Coverage Warranty

A Limited Warranty (see warranty periods below)

Landscape  
Contractor  
Equipment  
(LCE)

## Conditions and Products Covered

The Toro Company and its affiliate, Toro Warranty Company, pursuant to an agreement between them, jointly promise to the original purchaser to repair the Toro Products listed below if defective in materials or workmanship.

The following time periods apply from the date of purchase by the original owner:

Products	Warranty Period
21 in. Mowers	2 years Residential Use <sup>1</sup> 1 year Commercial Use
• Engines <sup>4</sup>	Honda – 2 years Kawasaki – 3 years
30 in. Mowers	2 years Residential Use <sup>1</sup> 1 year Commercial Use
• Engines <sup>4</sup>	Kawasaki – 3 years
Mid-Size Walk-Behind Mowers	2 years
• Engines <sup>4</sup>	Kawasaki – 3 years
Grand Stand® Mowers	5 years or 1,200 hours <sup>2</sup> 3 years
• Engines <sup>4</sup>	Lifetime (original owner only) <sup>3</sup>
• Frame	
Z Master® 2000 Series Mowers	4 years or 500 hours <sup>2</sup> 3 years
• Engines <sup>4</sup>	Lifetime (original owner only) <sup>3</sup>
• Frame	
Z Master® 3000 Series Mowers	5 years or 1,200 hours <sup>2</sup> 3 years
• Engines <sup>4</sup>	Lifetime (original owner only) <sup>3</sup>
• Frame	
Z Master® 5000 Series Mowers	5 years or 1,200 hours <sup>2</sup> Kohler Command – 2 years Kohler EFI – 3 years
• Engines <sup>4</sup>	Lifetime (original owner only) <sup>3</sup>
• Frame	
Z Master® 6000 Series Mowers	5 years or 1,200 hours <sup>2</sup> Kawasaki – 3 years
• Engines <sup>4</sup>	Lifetime (original owner only) <sup>3</sup>
• Frame	
Z Master® 7000 Series Mowers	5 years or 1,200 hours <sup>2</sup> 2 years
• Engines <sup>4</sup>	Lifetime (original owner only) <sup>3</sup>
• Frame	
Z Master® 8000 Series Mowers	2 years or 1,200 hours <sup>2</sup> 2 years
• Engines <sup>4</sup>	Lifetime (original owner only) <sup>3</sup>
• Frame	
All Mowers	
• Battery	90 days Parts and Labor 1 year Parts only
• Belts and Tires	90 days
• Attachments	1 year

<sup>1</sup>Residential use means use of the product on the same lot as your home. Use at more than one location is considered commercial use and the commercial warranty would apply.

<sup>2</sup>Whichever occurs first.

<sup>3</sup>Lifetime Frame Warranty - If the main frame, consisting of the parts welded together to form the tractor structure that other components such as the engine are secured to, cracks or breaks in normal use, it will be repaired or replaced, at Toro's option, under warranty at no cost for parts and labor. Frame failure due to misuse or abuse and failure or repair required due to rust or corrosion are not covered.

<sup>4</sup>Some engines used on Toro Products are warranted by the engine manufacturer.

## Instructions for Obtaining Warranty Service

If you think that your Toro Product contains a defect in materials or workmanship, follow this procedure:

1. Contact any Authorized Toro Service Dealer to arrange service at their dealership. To locate a dealer convenient to you, refer to the Yellow Pages of your telephone directory (look under "Lawn Mowers") or access our web site at [www.Toro.com](http://www.Toro.com). You may also call the numbers listed in item #3 to use the 24-hour Toro Dealer locator system.
2. Bring the product and your proof of purchase (sales receipt) to the Service Dealer. The dealer will diagnose the problem and determine if it is covered under warranty.
3. If for any reason you are dissatisfied with the Service Dealer's analysis or with the assistance provided, contact us at:

RLC Customer Care Department  
Toro Warranty Company  
8111 Lyndale Avenue South  
Bloomington, MN 55420-1196  
888-865-5676 (U.S. Customers)  
888-865-5691 (Canada customers)

## Owner Responsibilities

You must maintain your Toro Product by following the maintenance procedures described in the *Operator's Manual*. Such routine maintenance, whether performed by a dealer or by you, is at your expense.

## Items and Conditions Not Covered

There is no other express warranty except for special emission system coverage and engine warranty coverage on some products. This express warranty does not cover the following:

- Cost of regular maintenance service or parts, such as filters, fuel, lubricants, oil changes, spark plugs, air filters blade sharpening or worn blades, cable/linkage adjustments, or brake and clutch adjustments
- Components failing due to normal wear
- Any product or part which has been altered or misused or neglected and requires replacement or repair due to accidents or lack of proper maintenance
- Pickup and delivery charges
- Repairs or attempted repairs by anyone other than an Authorized Toro Service Dealer
- Repairs necessary due to failure to follow recommended fuel procedure (consult *Operator's Manual* for more details)
  - Removing contaminants from the fuel system is not covered
  - Use of old fuel (more than one month old) or fuel which contains more than 10% ethanol or more than 15% MTBE
  - Failure to drain the fuel system prior to any period of non-use over one month

## General Conditions

All repairs covered by these warranties must be performed by an Authorized Toro Service Dealer using Toro approved replacement parts.

**Neither The Toro Company nor Toro Warranty Company is liable for indirect, incidental or consequential damages in connection with the use of the Toro Products covered by this warranty, including any cost or expense of providing substitute equipment or service during reasonable periods of malfunction or non-use pending completion of repairs under this warranty.**

**All implied warranties of merchantability (that the product is fit for ordinary use) and fitness for use (that the product is fit for a particular purpose) are limited to the duration of the express warranty.**

**Some states do not allow exclusions of incidental or consequential damages, or limitations on how long an implied warranty lasts, so the above exclusions and limitations may not apply to you.**

This warranty gives you specific legal rights, and you may also have other rights which vary from state to state.

## Countries Other than the United States or Canada

Customers who have purchased Toro products outside the United States or Canada should contact their Toro Distributor (Dealer) to obtain guarantee policies for your country, province, or state. If for any reason you are dissatisfied with your Distributor's service or have difficulty obtaining guarantee information, contact the Toro importer. If all other remedies fail, you may contact us at Toro Warranty Company.

**Australian Consumer Law:** Australian customers will find details relating to the Australian Consumer Law either inside the box or at your local Toro Dealer.