



MODEL NO. 88-0600

**INSTALLATION  
INSTRUCTIONS**
**SNOW CAB KIT**

FOR CCR 1000™, CCR 2000®, 3521, 521 AND 724V SNOWTHROWERS

**KIT CONTENTS**

PART NUMBER	DESCRIPTION	QTY
88-0680	Cross Bar	1
88-0640	Frame, right	1
88-0700	Frame, left	1
88-0670	Bottom Bow	1
88-0630	Top Bow	1
88-0620	Top Frame	1
88-0610	Vinyl Cover	1
88-0650	Center Support	1
88-0660	Brace	2
	Hardware Package (contents listed below)	1
321-3	1/4" -20 x 5/8" Capscrew, hex	8
321-6	1/4" -20 x 1" Capscrew, hex	2
3296-16	1/4" Locknut	12
322-13	5/16" -18 x 2 3/4" Capscrew, hex	2
322-41	5/16" -18 x 1 3/4" Capscrew, hex	2
3296-47	5/16" Locknut	4
88-0690	3/4" "U" Clamp	2
88-0720	1 1/8" "U" Clamp	4
88-0710	7/8" "U" Clamp	4

**WARNING**

**MAKE ABSOLUTELY CERTAIN THAT THE  
INSTALLATION DOES NOT AFFECT MOVE-  
MENT OF THE CONTROLS IN ANY WAY.**

**TOOLS REQUIRED FOR INSTALLATION**

7/16" wrench (2)

1/2" wrench (2)

**MAINTENANCE INSTRUCTIONS**

Avoid rubbing contact with plastic windshield. Keep windshield plastic clean by washing it only with clear running water and by rubbing with your bare hands only. The use of a rag, sponge or brush may scratch

the plastic. Liquid soap may also be useful in cleaning the windshield. During freezing weather, an automotive windshield washer solvent may be used.

# ASSEMBLY INSTRUCTIONS

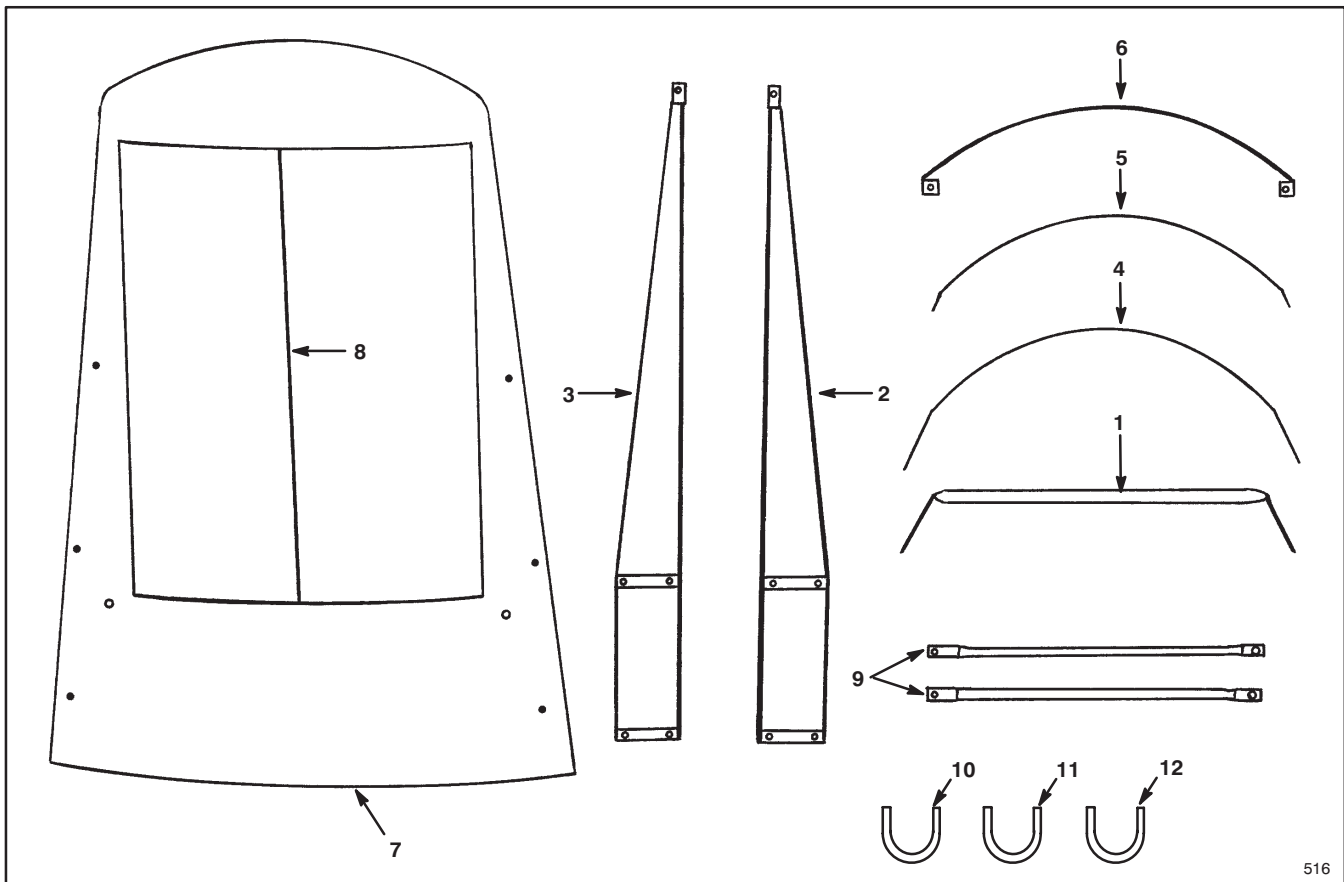

516

Figure 1

- |                |               |                   |                          |
|----------------|---------------|-------------------|--------------------------|
| 1. Cross bar   | 4. Bottom bow | 7. Vinyl cover    | 10. 3/4" "U" clamp (2)   |
| 2. Right frame | 5. Top bow    | 8. Center support | 11. 1 1/8" "U" clamp (4) |
| 3. Left frame  | 6. Top frame  | 9. Braces         | 12. 7/8" "U" clamp (4)   |

## ASSEMBLE SNOW CAB

1. Identify all of the steel parts using Figure 1 for reference.
2. Determine the right and left hand frames by making sure the straight frame rods are on the interior of the windshield (Fig. 2). The frame rod with a bend in it should be positioned to the outside of the windshield.
3. Using two 1/4" x 1" bolts and two 1/4" locknuts, assemble the right and left frames to the bottom bow at REFERENCE "A" as shown in Figure 2. Position locknut on the outside of the frame.
4. Insert two 1/4" x 5/8" bolts and two 1/4" locknuts in the holes at REFERENCE "B" as shown in Figure 2.
5. Tighten all four bolts and nuts.
6. Insert a 1/4" x 5/8" bolt outwards through the top of the right and left frame, the top bow and then through the top frame (Fig. 2). Add two 1/4" locknuts and tighten securely.

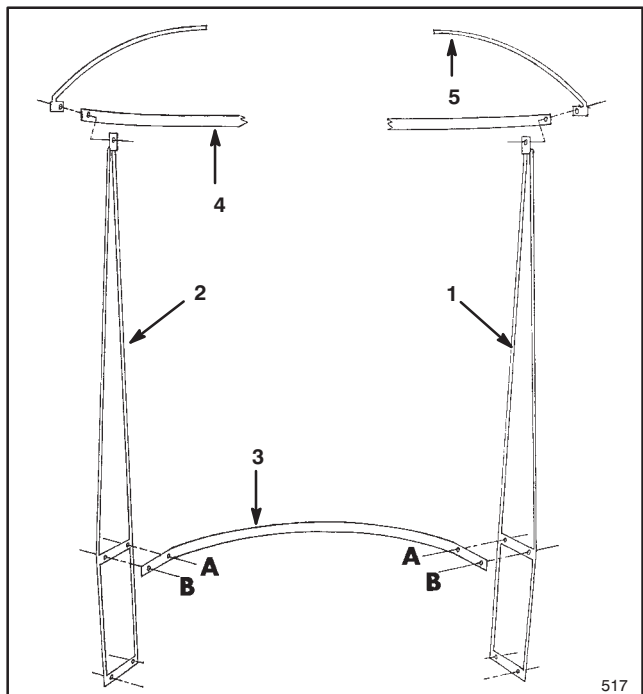

517

Figure 2

- |                |              |
|----------------|--------------|
| 1. Right frame | 4. Top bow   |
| 2. Left frame  | 5. Top frame |
| 3. Bottom bow  |              |

# ASSEMBLY INSTRUCTIONS

## ATTACH CROSS BAR TO CCR 1000™ SNOWTHROWERS (Fig. 3)

1. Place two  $\frac{7}{8}$ " U-clamps on the handle bars (open end to the inside). Insert two  $\frac{5}{16}$ " x  $2\frac{3}{4}$ " bolts down through the clamps.
2. Place two  $\frac{3}{4}$ " U-clamps on the cross bar. Place the cross bar under the handle bars and insert the bolts through the U-clamps. Add two  $\frac{5}{16}$ " locknuts and secure enough to hold the cross bar level and away from any moving parts.

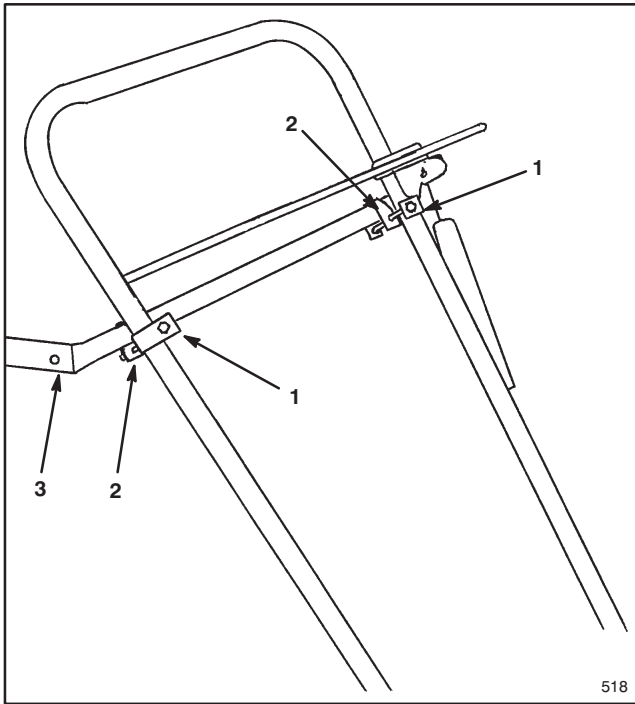

Figure 3

1.  $\frac{7}{8}$ " U-clamp    2.  $\frac{3}{4}$ " U-clamp    3. Cross bar

## ATTACH CROSS BAR TO CCR 2000® SNOWTHROWERS (Fig. 4)

1. Place two  $\frac{7}{8}$ " U-clamps on the handle bars (open end to the outside). Insert two  $\frac{5}{16}$ " x  $2\frac{3}{4}$ " bolts down through the clamps.
2. Place two  $\frac{3}{4}$ " U-clamps on the cross bar. Place the cross bar under the handle bars and insert the bolts through the U-clamps. Add two  $\frac{5}{16}$ " locknuts and secure enough to hold the cross bar level and away from any moving parts.

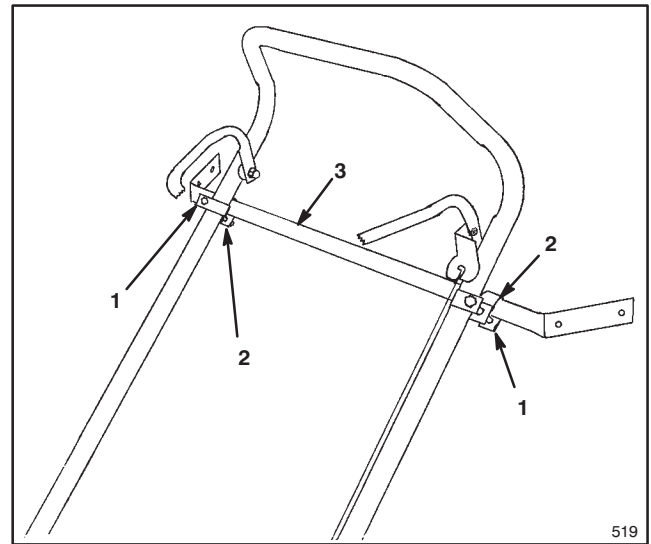

Figure 4

1.  $\frac{7}{8}$ " U-clamp    2.  $\frac{3}{4}$ " U-clamp    3. Cross bar

## ATTACH CROSS BAR TO 521/3521 AND 724V SNOWTHROWERS

1. Place two  $1\frac{1}{8}$ " U-clamps on the handle bars (open end to the outside). Place two  $\frac{3}{4}$ " U-clamps on the cross bar (Fig. 5).

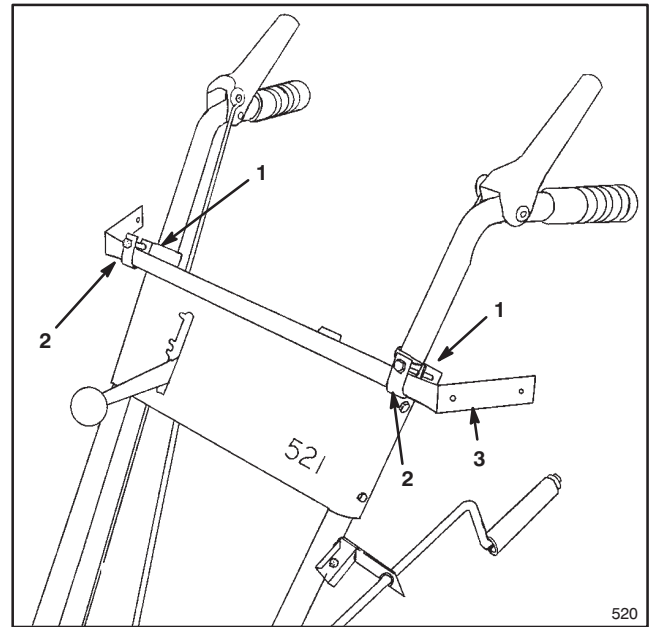

Figure 5

1.  $1\frac{1}{8}$ " U-clamp    2.  $\frac{3}{4}$ " U-clamp    3. Cross bar

2. Place the cross bar on top of the handle bars. Insert two  $\frac{5}{16}$ " x  $2\frac{3}{4}$ " bolts through the clamps. Add two  $\frac{5}{16}$ " locknuts and secure enough to hold the cross bar level and away from any moving parts.

# ASSEMBLY INSTRUCTIONS

## ATTACH SNOW CAB FRAME TO CROSS BAR ASSEMBLY (Fig. 6–8)

1. Place the assembled frame on the cross bar and secure it with four  $\frac{1}{4}$ " x  $\frac{5}{8}$ " bolts and  $\frac{1}{4}$ " locknuts (Fig. 6).

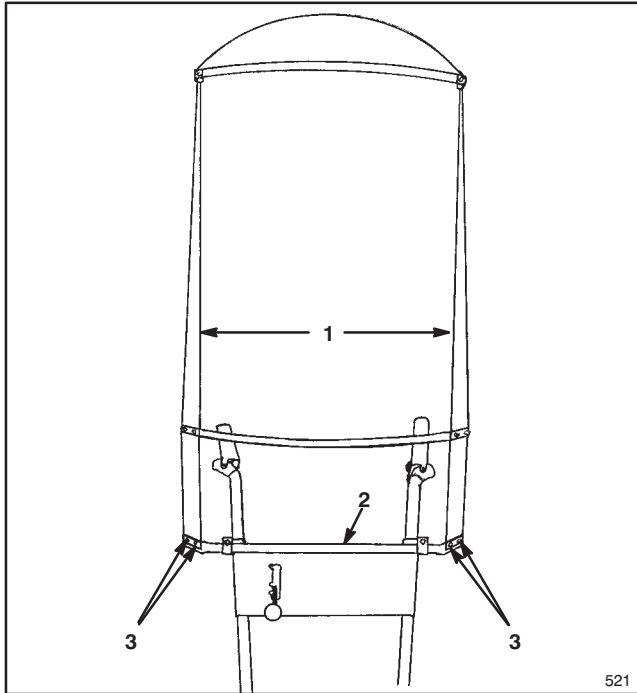

**Figure 6**

1. Assembled frame  
 2. Cross bar  
 3.  $\frac{1}{4}$ " x  $\frac{5}{8}$ " bolts and  $\frac{1}{4}$ " locknuts

2. Insert the ends of the windshield center support into the tabs above and below the windshield. Position the end of the center support with the bend in it at the top of the windshield.

3. Place the vinyl cover over the frame (Fig. 7). Close the snaps in order to cover the rear of the framework.

4. Locate the end of the brace with the smallest hole. Place the flat side of that end over the 1" bolt protruding from the snow cab frame (Fig. 7). Add a  $\frac{1}{4}$ " locknut. **DO NOT TIGHTEN THE LOCKNUT.**

5. Place two U-clamps ( $\frac{7}{8}$ " for CCR 1000™ & CCR 2000® or  $1\frac{1}{8}$ " for 521/3521/724V) on the handle bars below the controls (Fig. 7 & 8). See following chart for the correct position of these U-clamps.

U-CLAMP POSITIONS	
CCR 1000	— Keep open end forward.
CCR 2000	— Open end to the rear.
521/3521/724V	— Open end forward.

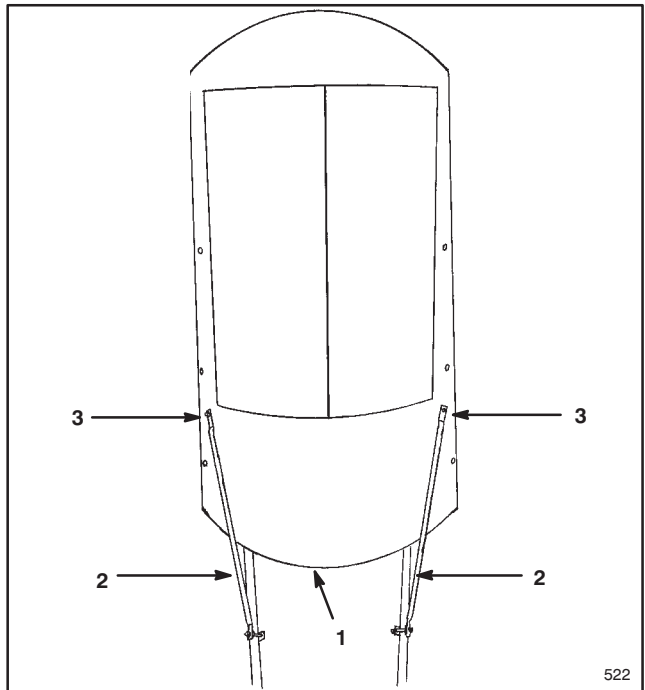

**Figure 7**

1. Vinyl cover  
 2. Brace  
 3. 1" bolt

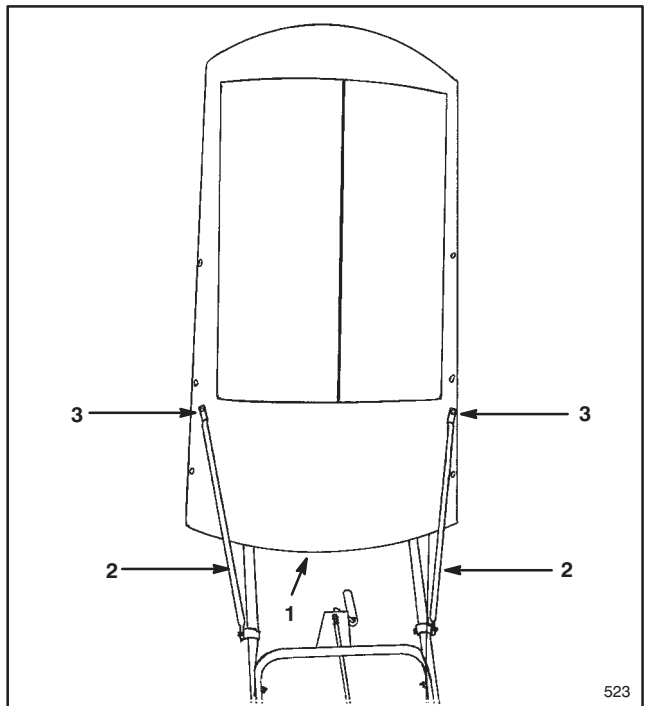

**Figure 8**

1. Vinyl cover  
 2. Brace  
 3. 1" bolt

6. Insert a  $\frac{5}{16}$ " x  $1\frac{3}{4}$ " bolt through the bottom hole of the brace, then through the U-clamp. Add a  $\frac{5}{16}$ " locknut, but do not tighten. Repeat on the other side of the unit.

7. Adjust the frame of the windshield to the desired angle. Secure all bolts associated with the assembly.