



Count on it.

Operator's Manual

Groundsmaster® 4300-D Traction Unit

Model No. 30853—Serial No. 315000001 and Up

Model No. 30854—Serial No. 315000001 and Up



This product complies with all relevant European directives, for details please see the separate product specific Declaration of Conformity (DOC) sheet.

which signals a hazard that may cause serious injury or death if you do not follow the recommended precautions.

▲ WARNING

CALIFORNIA Proposition 65 Warning

This product contains a chemical or chemicals known to the State of California to cause cancer, birth defects, or reproductive harm.

Diesel engine exhaust and some of its constituents are known to the State of California to cause cancer, birth defects, and other reproductive harm.

Important: This engine is not equipped with a spark arrester muffler. It is a violation of California Public Resource Code Section 4442 to use or operate the engine on any forest-covered, brush-covered, or grass-covered land. Other states or federal areas may have similar laws.



Figure 1

1. Safety alert symbol

This manual uses 2 other words to highlight information. **Important** calls attention to special mechanical information and **Note** emphasizes general information worthy of special attention.

Introduction

This machine is a ride-on, rotary-blade lawn mower intended to be used by professional, hired operators in commercial applications. It is primarily designed for cutting grass on well-maintained lawns in parks, sports fields, and on commercial grounds. It is not designed for cutting brush, mowing grass and other growth alongside highways, or for agricultural uses.

Read this information carefully to learn how to operate and maintain your product properly and to avoid injury and product damage. You are responsible for operating the product properly and safely.

You may contact Toro directly at www.Toro.com for product and accessory information, help finding a dealer, or to register your product.

Whenever you need service, genuine Toro parts, or additional information, contact an Authorized Service Dealer or Toro Customer Service and have the model and serial numbers of your product ready. The model and serial numbers are on a plate mounted on the left side of the frame under the foot rest. Write the numbers in the space provided.

Model No. _____

Serial No. _____

This manual identifies potential hazards and has safety messages identified by the safety alert symbol (Figure 1),

Contents

Safety	4	Checking the Fuel Lines and Connections	41
Safe Operating Practices	4	Servicing the Water Separator	41
Toro Riding Mower Safety	6	Fuel Pick-up Tube Screen	42
Sound Power Level	6	Bleeding Air from the Fuel Injectors.....	42
Sound Pressure Level.....	6	Electrical System Maintenance	43
Vibration Level	7	Servicing the Battery	43
Safety and Instructional Decals	8	Fuses	43
Setup	13	Drive System Maintenance	44
1 Adjusting the Tire Pressure.....	13	Adjusting the Traction Drive for Neutral.....	44
2 Adjusting the Step Height	14	Adjusting the Rear Wheel Toe-in	44
3 Adjusting the Control Arm Position.....	14	Cooling System Maintenance	45
4 Remove the Shipping Blocks and Pins	14	Removing Debris from the Cooling System	45
5 Installing Rear Weights	15	Brake Maintenance	46
6 Installing the Hood Latch for CE	15	Adjusting the Parking Brakes.....	46
Compliance.....	16	Adjusting the Parking Brake Latch	46
7 Installing the Throttle Stop for CE	16	Belt Maintenance	47
Compliance.....	17	Tensioning the Alternator Belt	47
8 Adjusting the Carrier Frame	17	Hydraulic System Maintenance	47
9 Adjusting the Height-of-Cut.....	18	Changing the Hydraulic Fluid.....	47
10 Adjusting the Roller Scraper (Optional)	18	Replacing the Hydraulic Filters	48
11 Installing the Mulching Baffle (Optional)	19	Checking the Hydraulic Lines and Hoses.....	48
Product Overview	19	Hydraulic System Test Ports.....	49
Controls	19	Cutting Deck Maintenance	49
Specifications	24	Separating the Cutting Decks from the Traction	49
Attachments/Accessories.....	24	Unit	49
Operation	24	Mounting the Cutting Decks to the Traction	49
Checking the Engine Oil Level	24	Unit	49
Checking the Cooling System.....	25	Servicing the Blade Plane.....	50
Adding Fuel.....	26	Servicing the Cutter Blade	50
Checking the Hydraulic Fluid	27	Servicing the Front Roller.....	52
Check the Torque of the Wheel Nuts	28	Storage	53
Breaking-in the Machine.....	28	Preparing the Traction Unit	53
Bleeding the Fuel System.....	28	Preparing the Engine	53
Starting and Stopping the Engine.....	28	Cutting Deck	53
Pushing or Towing the Machine.....	29		
Jacking Points	29		
Tie Downs	30		
Understanding the Diagnostic Light.....	30		
Changing the Counterbalance Settings.....	30		
Checking the Interlock Switches	30		
Hydraulic Valve Solenoid Functions	31		
Selecting a Blade.....	31		
Choosing Accessories	33		
Operating Tips	33		
Maintenance	35		
Recommended Maintenance Schedule(s)	35		
Daily Maintenance Checklist	36		
Service Interval Chart	37		
Lubrication	37		
Greasing the Bearings and Bushings	37		
Engine Maintenance	39		
Servicing the Air Cleaner	39		
Servicing the Engine Oil and Filter.....	40		
Adjusting the Throttle.....	40		
Fuel System Maintenance	41		
Draining the Fuel Tank	41		

Safety

This machine meets or exceeds CEN standard EN ISO 5395:2013 and ANSI B71.4-2012 specifications in effect at time of production, when equipped with rear weight. Refer to the section in this manual on Installing Rear Weight.

Improper use or maintenance by the operator or owner can result in injury. To reduce the potential for injury, comply with these safety instructions and always pay attention to the safety alert symbol, which means Caution, Warning, or Danger—personal safety instruction. Failure to comply with the instruction may result in personal injury or death.

Safe Operating Practices

The following instructions are adapted from the EN ISO 5395:2013 and ANSI B71.4-2012.

Training

- Read the operator's manual and other training material carefully. Be familiar with the controls, safety signs, and the proper use of the equipment.
- Never allow children or people unfamiliar with these instructions to use or service the mower. Local regulations may restrict the age of the operator.
- Never mow while people, especially children, or pets are nearby.
- Keep in mind that the operator or user is responsible for accidents or hazards occurring to other people or their property.
- Do not carry passengers.
- All drivers and mechanics should seek and obtain professional and practical instruction. The owner is responsible for training the users. Such instruction should emphasize:
 - the need for care and concentration when working with ride-on machines;
 - control of a ride-on machine sliding on a slope will not be regained by the application of the brake. The main reasons for loss of control are:
 - ◇ insufficient wheel grip;
 - ◇ being driven too fast;
 - ◇ inadequate braking;
 - ◇ the type of machine is unsuitable for its task;
 - ◇ lack of awareness of the effect of ground conditions, especially slopes;
 - ◇ incorrect hitching and load distribution.
- The owner/user can prevent and is responsible for accidents or injuries occurring to himself or herself, other people, or property.

Safe Handling of Fuels

- To avoid personal injury or property damage, use extreme care in handling gasoline. Gasoline is extremely flammable and the vapors are explosive.
- Extinguish all cigarettes, cigars, pipes, and other sources of ignition.
- Use only an approved fuel container.
- Never remove fuel cap or add fuel with the engine running.
- Allow engine to cool before refueling.
- Never refuel the machine indoors.
- Never store the machine or fuel container where there is an open flame, spark, or pilot light such as on a water heater or on other appliances.
- Never fill containers inside a vehicle or on a truck or trailer bed with a plastic liner. Always place containers on the ground away from your vehicle before filling.
- Remove equipment from the truck or trailer and refuel it on the ground. If this is not possible, then refuel such equipment with a portable container, rather than from a fuel dispenser nozzle.
- Keep the nozzle in contact with the rim of the fuel tank or container opening at all times until fueling is complete. Do not use a nozzle lock open device.
- If fuel is spilled on clothing, change clothing immediately.
- Never overfill fuel tank. Replace fuel cap and tighten securely.

Preparation

- While mowing, always wear substantial, slip-resistant footwear, long trousers, hard hat, safety glasses, and ear protection. Long hair, loose clothing, or jewelry may get tangled in moving parts. Do not operate the equipment when barefoot or wearing open sandals.
- Thoroughly inspect the area where the equipment is to be used and remove all objects which may be thrown by the machine.
- Replace faulty silencers/mufflers.
- Evaluate the terrain to determine what accessories and attachments are needed to properly and safely perform the job. Only use accessories and attachments approved by the manufacturer.
- Check that the operator's presence controls, safety switches and shields are attached and functioning properly. Do not operate unless they are functioning properly.

Operation

- Do not operate the engine in a confined space where dangerous carbon monoxide and exhaust gases can collect.

- Mow only in daylight or in good artificial light.
- Before attempting to start the engine, disengage all blade attachment clutches, shift into neutral, and engage the parking brake.
- Remember there is no such thing as a safe slope. Travel on grass slopes requires particular care. To guard against overturning:
 - do not stop or start suddenly when going up or downhill;
 - machine speeds should be kept low on slopes and during tight turns;
 - stay alert for humps and hollows and other hidden hazards;
 - Do not turn sharply. Use care when reversing.
 - Use counterweight(s) or wheel weights as identified in the operator's manual.
- Stay alert for holes in the terrain and other hidden hazards.
- Watch out for traffic when crossing or near roadways.
- Stop the blades rotating before crossing surfaces other than grass.
- When using any attachments, never direct discharge of material toward bystanders nor allow anyone near the machine while in operation.
- Never operate the machine with damaged guards, shields, or without safety protective devices in place. Be sure all interlocks are attached, adjusted properly, and functioning properly.
- Do not change the engine governor settings or over-speed the engine. Operating the engine at excessive speed may increase the hazard of personal injury.
- Before leaving the operator's position:
 - stop on level ground;
 - disengage the power take-off and lower the attachments;
 - change into neutral and set the parking brake;
 - stop the engine and remove the key.
- Disengage drive to attachments when transporting or not in use.
- Stop the engine and disengage drive to attachment:
 - before refuelling;
 - before removing the grass catcher/catchers;
 - before making height adjustment unless adjustment can be made from the operator's position.
 - before clearing blockages;
 - before checking, cleaning or working on the mower;
 - after striking a foreign object or if an abnormal vibration occurs. Inspect the mower for damage and make repairs before restarting and operating the equipment.
- Reduce the throttle setting during engine run-out and, if the engine is provided with a shut-off valve, turn the fuel off at the conclusion of mowing.
- Keep hands and feet away from the cutting decks.
- Look behind and down before backing up to be sure of a clear path.
- Slow down and use caution when making turns and crossing roads and sidewalks.
- Do not operate the mower under the influence of alcohol or drugs.
- Lightning can cause severe injury or death. If lightning is seen or thunder is heard in the area, do not operate the machine; seek shelter.
- Use care when loading or unloading the machine into a trailer or truck.
- Use care when approaching blind corners, shrubs, trees, or other objects that may obscure vision.

Maintenance and Storage

- Keep all nuts, bolts and screws tight to be sure the equipment is in safe working condition.
- Never store the equipment with fuel in the tank inside a building where fumes may reach an open flame or spark.
- Allow the engine to cool before storing in any enclosure.
- To reduce the fire hazard, keep the engine, silencer/muffler, battery compartment and fuel storage area free of grass, leaves, or excessive grease.
- Keep all parts in good working condition and all hardware and hydraulic fittings tightened. Replace all worn or damaged parts and decals.
- If the fuel tank has to be drained, do this outdoors.
- Be careful during adjustment of the machine to prevent entrapment of the fingers between moving blades and fixed parts of the machine.
- Disengage drives, lower the cutting decks, set parking brake, stop engine and remove key from ignition. Wait for all movement to stop before adjusting, cleaning or repairing.
- Clean grass and debris from cutting decks, drives, silencers/mufflers, and engine to help prevent fires. Clean up oil or fuel spillage.
- Use jack stands to support components when required.
- Carefully release pressure from components with stored energy.
- Disconnect battery before making any repairs. Disconnect the negative terminal first and the positive last. Reconnect positive first and negative last.
- Keep hands and feet away from moving parts. If possible, do not make adjustments with the engine running.
- Charge batteries in an open well ventilated area, away from spark and flames. Unplug charger before connecting or disconnecting from battery. Wear protective clothing and use insulated tools.

Hauling

- Use care when loading or unloading the machine into a trailer or truck.
- Use full width ramps for loading machine into trailer or truck.
- Tie the machine down securely using straps, chains, cable, or ropes. Both front and rear straps should be directed down and outward from the machine

Toro Riding Mower Safety

The following list contains safety information specific to Toro products or other safety information that you must know that is not included in the CEN, ISO, or ANSI standard.

This product is capable of amputating hands and feet and throwing objects. Always follow all safety instructions to avoid serious injury or death.

Use of this product for purposes other than its intended use could prove dangerous to user and bystanders.

▲ WARNING

Engine exhaust contains carbon monoxide, which is an odorless, deadly poison that can kill you.

Do not run engine indoors or in an enclosed area.

- Know how to stop the engine quickly.
- Do not operate the machine while wearing tennis shoes or sneakers.
- Wearing safety shoes and long pants is advisable and required by some local ordinances and insurance regulations.
- Handle fuel carefully. Wipe up any spills.
- Check the safety interlock switches daily for proper operation. If a switch should fail, replace the switch before operating the machine.
- Before starting the engine, sit on the seat.
- Using the machine demands attention. To prevent loss of control:
 - Do not drive close to sand traps, ditches, creeks, or other hazards.
 - Reduce speed when making sharp turns. Avoid sudden stops and starts.
 - When near or crossing roads, always yield the right-of-way.
 - Apply the service brakes when going downhill to keep forward speed slow and to maintain control of the machine.
- Raise the cutting decks when driving from one work area to another.
- Do not touch the engine, silencer/muffler, or exhaust pipe while the engine is running or soon after it has

stopped because these areas could be hot enough to cause burns.

- If the engine stalls or loses headway and cannot make it to the top of a slope, do not turn the machine around. Always back slowly, straight down the slope.
- When a person or pet appears unexpectedly in or near the mowing area, stop mowing. Careless operation, combined with terrain angles, ricochets, or improperly positioned guards can lead to thrown object injuries. Do not resume mowing until the area is cleared.

Maintenance and Storage

- Make sure all hydraulic line connectors are tight and all hydraulic hoses and lines are in good condition before applying pressure to the system.
- Keep your body and hands away from pin hole leaks or nozzles that eject hydraulic fluid under high pressure. Use paper or cardboard, not your hands, to search for leaks. Hydraulic fluid escaping under pressure can have sufficient force to penetrate the skin and cause serious injury. Seek immediate medical attention if fluid is injected into skin.
- Before disconnecting or performing any work on the hydraulic system, all pressure in the system must be relieved by stopping the engine and lowering the cutting decks and attachments to the ground.
- Check all fuel lines for tightness and wear on a regular basis. Tighten or repair them as needed.
- If the engine must be running to perform a maintenance adjustment, keep hands, feet, clothing, and any parts of the body away from the cutting decks, attachments, and any moving parts. Keep everyone away.
- To ensure safety and accuracy, have an Authorized Toro Distributor check the maximum engine speed with a tachometer.
- If major repairs are ever needed or if assistance is desired, contact an Authorized Toro Distributor.
- Use only Toro-approved attachments and replacement parts. The warranty may be voided if used with unapproved attachments.

Sound Power Level

This unit has a guaranteed sound power level of 105dBA, which includes an Uncertainty Value (K) of 1dBA.

Sound power level was determined according to the procedures outlined in EN 11094.

Sound Pressure Level

This unit has a sound pressure level at the operator's ear of 93 dBA, which includes an Uncertainty Value (K) of 1 dBA.

Sound pressure level was determined according to the procedures outlined in EN ISO 5395:2013.

Vibration Level

Hand-Arm

Measured vibration level for right hand = 0.86 m/s^2

Measured vibration level for left hand = 0.72 m/s^2

Uncertainty Value (K) = 0.5 m/s^2

Measured values were determined according to the procedures outlined in EN ISO 5395:2013.

Whole Body

Measured vibration level = 0.65 m/s^2

Uncertainty Value (K) = 0.5 m/s^2

Measured values were determined according to the procedures outlined in EN ISO 5395:2013.

Safety and Instructional Decals



Safety decals and instructions are easily visible to the operator and are located near any area of potential danger. Replace any decal that is damaged or lost.

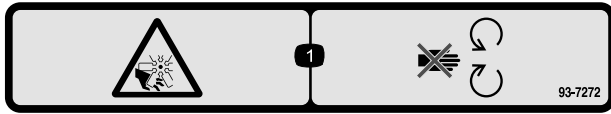

93-7272

1. Cutting/dismemberment hazard; fan—stay away from moving parts.

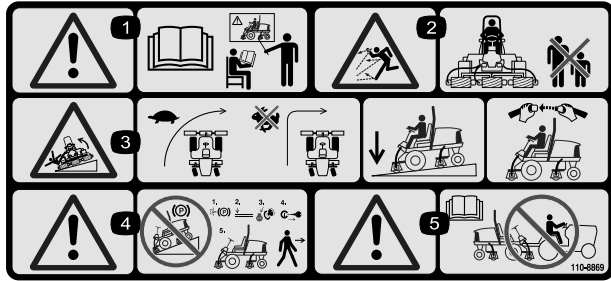

110-8869

1. Warning—read the *Operator's Manual*, do not operate this machine unless you are trained.
2. Thrown object hazard—keep bystanders a safe distance from the machine.
3. Tipping hazard—slow machine before turning, do not turn at high speeds; lower the cutting unit when driving down slopes; use a roll over protection system and wear the seat belt. Always wear a seat belt when a ROPS is in place.
4. Warning—do not park the machine on slopes; engage the parking brake, lower the cutting decks, stop the engine and remove the ignition key before leaving the machine.
5. Warning—read the *Operator's Manual*, do not tow the machine.

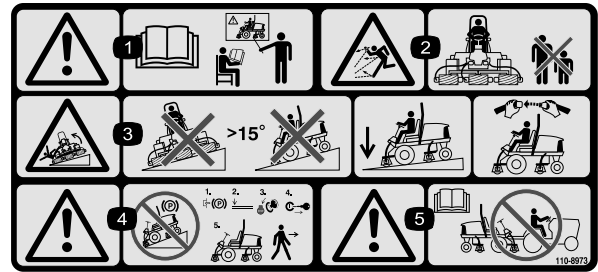

110-8973

(Affix over part no. 110-8869 for CE*)

*This safety decal includes a slope warning required on the machine for compliance to the European Lawn Mower Standard EN ISO 5395:2013. The conservative maximum slope angles indicated for operation of this machine are prescribed by and required by this standard.

1. Warning—read the *Operator's Manual*, do not operate this machine unless you are trained.
2. Thrown object hazard—keep bystanders a safe distance from the machine.
3. Tipping hazard—do not operate on slopes greater than 15°; lower the cutting decks when operating on slopes; wear the safety belt.
4. Warning—do not park the machine on slopes; engage the parking brake, lower the cutting decks, stop the engine and remove the ignition key before leaving the machine
5. Warning—read the *Operator's Manual* before towing the machine.

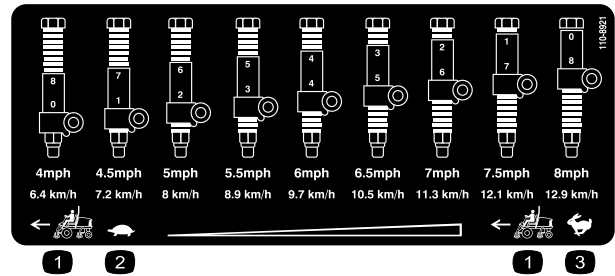

110-8921

1. Traction unit speed
2. Slow
3. Fast

CALIFORNIA SPARK ARRESTER WARNING

Operation of this equipment may create sparks that can start fires around dry vegetation. A spark arrester may be required. The operator should contact local fire agencies for laws or regulations relating to fire prevention requirements. 117-2718

117-2718

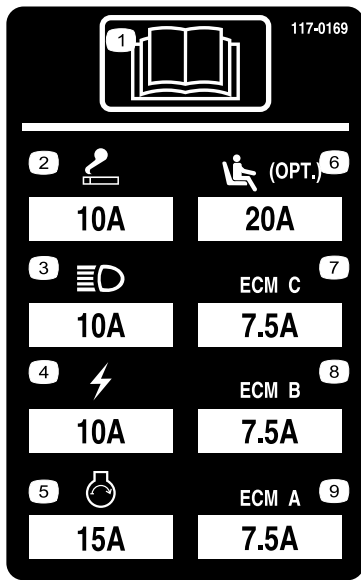

117-0169

1. Read the *Operator's Manual*.
2. Power point—10 amp
3. Head lights—10 amp
4. Power—10 amp
5. Engine start—15 amp
6. Optional air ride seat suspension—20 amp
7. Engine computer management C—7.5 amp
8. Engine computer management B—7.5 amp
9. Engine computer management A—7.5 amp

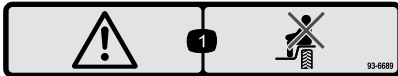

93-6689

1. Danger—do not sit on the plastic shroud.

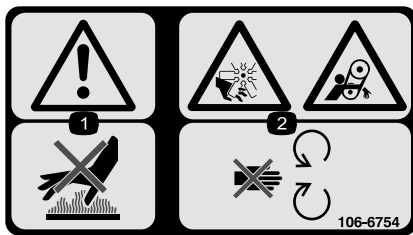

106-6754

1. Warning—do not touch the hot surface.
2. Cutting/dismemberment hazard, fan and entanglement hazard, belt—stay away from moving parts.

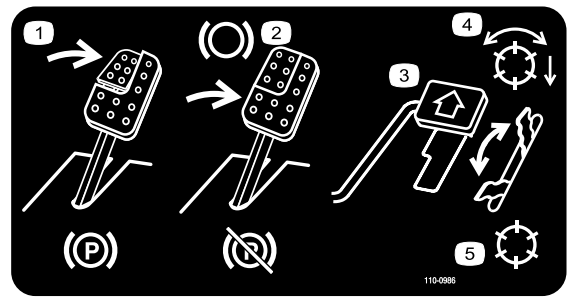

110-0986

1. Press the brake pedal and parking brake pedal to set the parking brake.
2. Press the brake pedal to apply the brake.
3. Press the traction pedal to move the machine forward.
4. Reel enabled mode
5. Transport mode

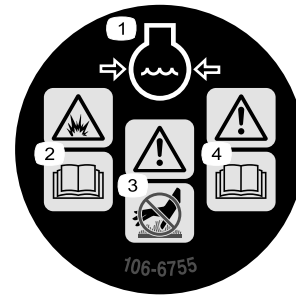

106-6755

1. Engine coolant under pressure.
2. Explosion hazard—read the *Operator's Manual*.
3. Warning—do not touch the hot surface.
4. Warning—read the *Operator's Manual*.

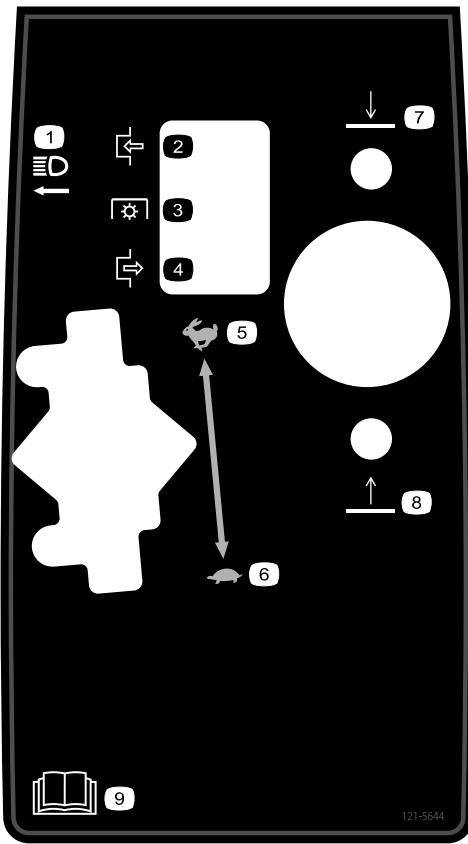

121-5644

- | | |
|-------------------|--|
| 1. Light switch | 6. Slow |
| 2. Engage | 7. Lower |
| 3. Power take-off | 8. Raise |
| 4. Disengage | 9. Read the <i>Operator's Manual</i> . |
| 5. Fast | |

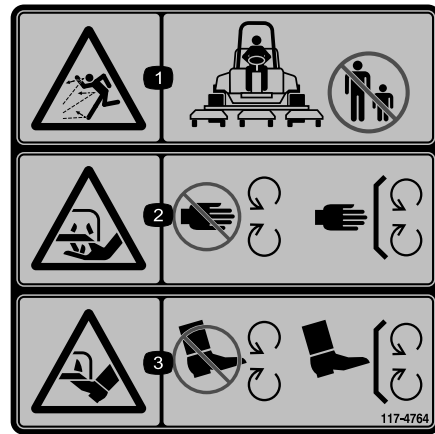

117-4764

1. Thrown object hazard—keep bystanders a safe distance from the machine.
2. Cutting hazard of hand, mower blade—stay away from moving parts, keep all guards and shields in place.
3. Cutting hazard of foot, mower blade—stay away from moving parts, keep all guards and shields in place.

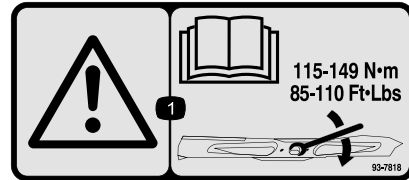

93-7818

1. Warning—read the *Operator's Manual* for instructions on torquing the blade bolt/nut to 115-149 N-m (85-110 ft-lb).

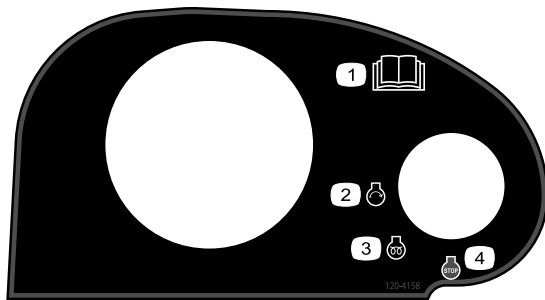

120-4158

- | | |
|--|-------------------|
| 1. Read the <i>Operator's Manual</i> . | 3. Engine—preheat |
| 2. Engine—start | 4. Engine—stop |

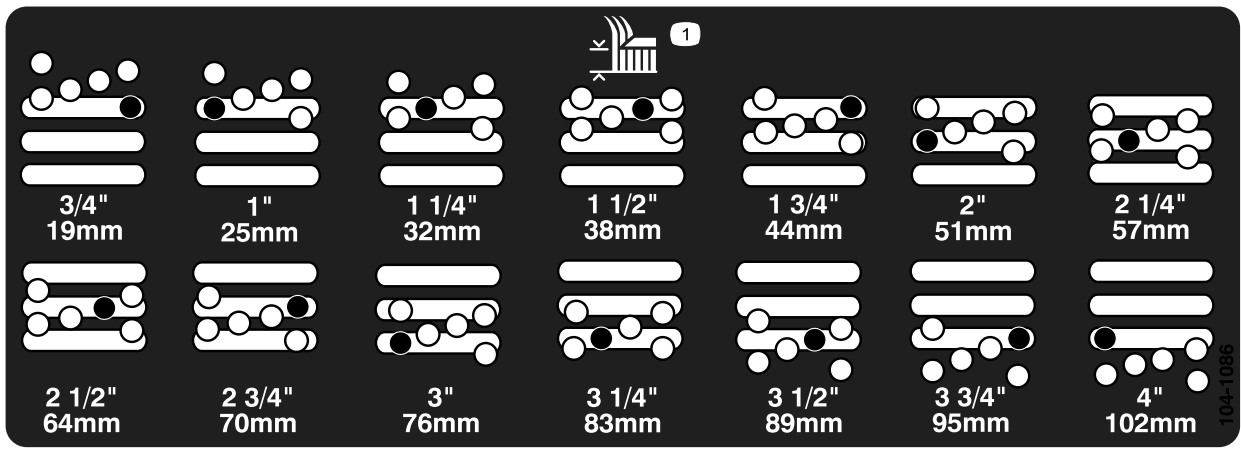

104-1086

1. Height of cut

REELMASTER 5410 / 5510 / 5610 & GROUNDMASTER 4300 QUICK REFERENCE AID

CHECK/SERVICE (daily)

- OIL LEVEL-ENGINE
- OIL LEVEL- HYDRAULIC TANK
- COOLANT LEVEL, RADIATOR
- FUEL /WATER SEPARATOR
- PRECLEANER – AIR CLEANER
- RADIATOR SCREEN
- BRAKE FUNCTION
- TIRE PRESSURE
- BATTERY
- BELTS (FAN, ALT.)
- BELTS -- SEE OPERATOR'S MANUAL

GREASING -- SEE OPERATOR'S MANUAL

FLUID SPECIFICATIONS/CHANGE INTERVALS

SEE OPERATOR'S MANUAL FOR INITIAL CHANGES.	FLUID TYPE	CAPACITY	CHANGE INTERVAL		FILTER PART NO.
			FLUID	FILTER	
A. ENGINE OIL	SAE 15W-40CI-4	5.5 QTS.	150 HRS.	150 HRS.	104-5167
B. HYD. CIRCUIT OIL	ISO VG 46/68	15 GALS.*	800 HRS.	SEE INDICATOR	94-2621
				800 HRS.	86-3010
C. AIR CLEANER				SEE INDICATOR	108-3810 (5410) (5510)
				SEE INDICATOR	108-3812 (5610) (4300)
D. WATER SEPARATOR			400 HRS.		110-9049
E. FUEL TANK	NO. 2-DIESEL	14 GALS.	DRAIN AND FLUSH, 2 YRS.		
		7.0 QTS. (5410) (5510)			
F. COOLANT	50/50 ETHYLENE GLYCOL/WATER	10.0 QTS. (5610) (4300)	DRAIN AND FLUSH, 2 YRS.		

* INCLUDING FILTER

125-8753

1. Read the *Operator's Manual* for more maintenance information.



Battery Symbols

Some or all of these symbols are on your battery

- | | |
|--|--|
| 1. Explosion hazard | 6. Keep bystanders a safe distance from the battery. |
| 2. No fire, open flame, or smoking. | 7. Wear eye protection; explosive gases can cause blindness and other injuries |
| 3. Caustic liquid/chemical burn hazard | 8. Battery acid can cause blindness or severe burns. |
| 4. Wear eye protection | 9. Flush eyes immediately with water and get medical help fast. |
| 5. Read the <i>Operator's Manual</i> . | 10. Contains lead; do not discard. |
-

Setup

Loose Parts

Use the chart below to verify that all parts have been shipped.

Procedure	Description	Qty.	Use
1	No parts required	–	Adjust the tire pressure.
2	No parts required	–	Adjust the step height.
3	No parts required	–	Adjust the control arm position.
4	No parts required	–	Remove shipping blocks and pins
5	Rear weights (quantity varies with configuration).	Varies	Install rear weights (order from your Toro Distributor).
6	Hood latch assembly Washer	1 1	Install the hood latch for CE compliance
7	Throttle stop Set screw	1 1	Install the throttle stop for CE compliance
8	No parts required	–	Adjust the carrier frame
9	No parts required	–	Adjust the height-of-cut
10	No parts required	–	Adjust the roller scraper (Optional)
11	No parts required	–	Install the mulching baffle (Optional)

Media and Additional Parts

Description	Qty.	Use
Operator's Manual	1	Review before operating machine
Engine Operator's Manual	1	
Parts Catalog	1	
Declaration of Conformity	1	
Operator Training Material	1	

Note: Determine the left and right sides of the machine from the normal operating position.

1

Adjusting the Tire Pressure

No Parts Required

Procedure

The tires are over-inflated for shipping. Therefore, release some of the air to reduce the pressure. Correct air pressure in the front and rear tires is 83 to 103 kPa (12 to 15 psi).

Important: Maintain even pressure in all tires to ensure uniform contact with the turf.

2

Adjusting the Step Height

No Parts Required

Procedure

The height of the steps can be adjusted for the operators comfort.

1. Remove the 2 bolts and nuts securing the step brackets to the traction unit frame (Figure 2)

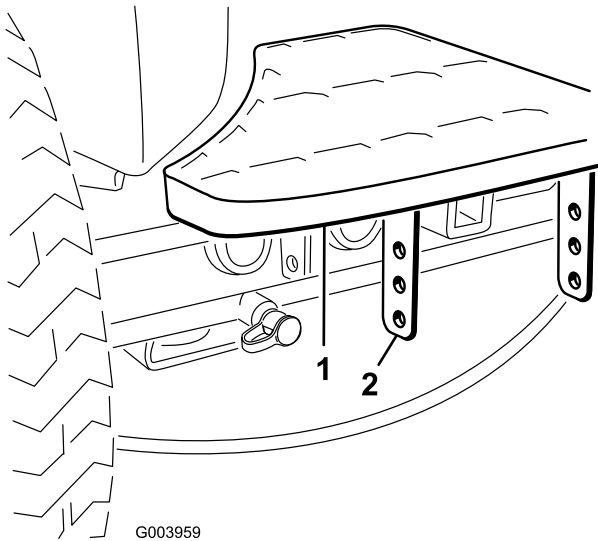

G003959

Figure 2

1. Step
2. Step brackets

2. Raise or lower the step to the desired height and re-secure the brackets to the frame with the 2 bolts and nuts.
3. Repeat the procedure on the other step.

3

Adjusting the Control Arm Position

No Parts Required

Procedure

The control arm position can be adjusted for the operators comfort.

1. Loosen the 2 bolts securing the control arm to the retaining bracket (Figure 3).

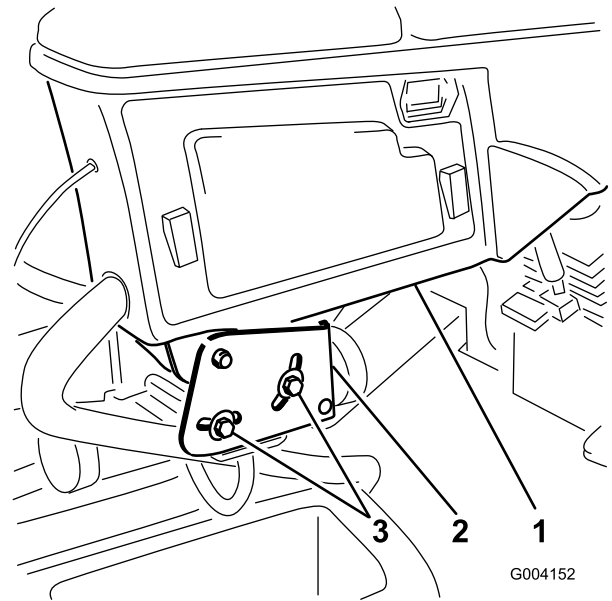

G004152

Figure 3

1. Control arm
2. Retaining brackets
3. Bolts (2)

2. Rotate the control arm to the desired position and tighten the 2 bolts.

4

Remove the Shipping Blocks and Pins

No Parts Required

Procedure

1. Remove and discard the shipping blocks from the cutting decks.
2. Remove and discard the shipping pins from the cutting deck suspension arms. The shipping pins stabilize the cutting decks during shipping and must be removed before operation.

5

Installing Rear Weights

Parts needed for this procedure:

Varies	Rear weights (quantity varies with configuration).
--------	--

Procedure

The Groundsmaster 4300–D Traction Unit complies with EN ISO 5395:2013 and ANSI B71.4-2012 Standards when equipped with rear weights and/or 90 lb of calcium chloride ballast is added to rear wheels. Use the following charts to determine the combinations of weights required for your configuration. Order parts from your local Authorized Toro Distributor.

Weight P/N 110-8985-03				
Configuration	Number of weights to meet ANSI (US) standards	Number of weights to meet CE (European) standards	Fasteners (2 each required) for weights	Weight Location
Base Unit	6	0	3231–34 Carriage Bolt 104–8301 Nut	3 on top of bumper and 3 under bumper
With Recycler Kit	90 lb calcium chloride*	0	N/A	N/A
With Sunshade	90 lb calcium chloride*	4	3231–7 Carriage Bolt 104–8301 Nut	1 on top of bumper and 3 under bumper
With 4 Post ROPS & Sunshade	90 lb calcium chloride*	4	3231–7 Carriage Bolt 104–8301 Nut	1 on top of bumper and 3 under bumper

* Install tubes inside the rear tires before adding calcium chloride.

Important: Always install tubes inside the rear tires before calcium chloride is installed. If a puncture occurs in a tire with calcium chloride, remove the machine from the turf area as quickly as possible. To prevent possible damage to the turf, immediately soak the affected area with water.

Use the following procedure to mount the appropriate amount of weight (see weight charts) to the top or bottom of the rear bumper as shown in Figure 4.

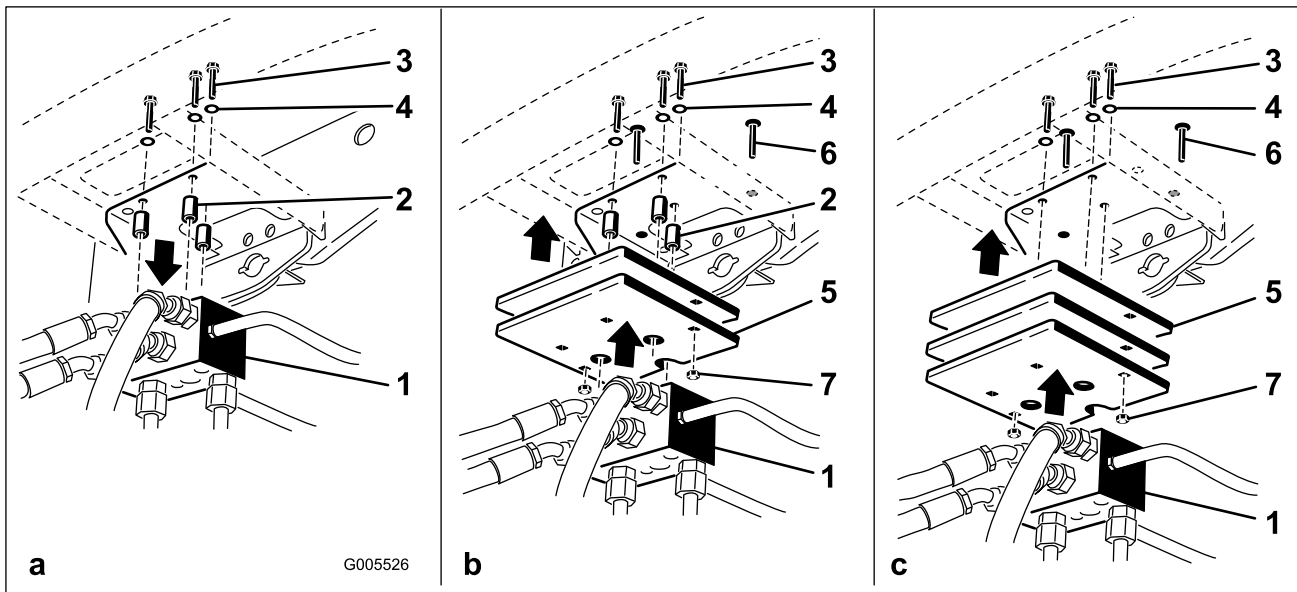

Figure 4

- | | |
|----------------------|------------------|
| 1. Traction manifold | 5. Weight(s) |
| 2. Spacers | 6. Carriage bolt |
| 3. Bolts | 7. Nut |
| 4. Washers | |

- Remove the 3 bolts, washers, and spacers securing the traction manifold to the bottom of the rear bumper (Figure 4a).
- Position the appropriate amount of weight on the top and/or bottom of the rear bumper.
- Mount the weight(s) and the traction manifold to the bumper with the 3 bolts, washers and spacers previously removed (Figure 4b).

Note: Do not use the spacers when installing more than two weights **under** the bumper (Figure 4c).

- Secure the outer edges of the weight(s) to the bumper with 2 carriage bolts and nuts (Figure 4c).

6

Installing the Hood Latch for CE Compliance

Parts needed for this procedure:

1	Hood latch assembly
1	Washer

Procedure

1. Unlatch and raise the hood.
2. Remove the rubber grommet from the hole in the left side of the hood (Figure 5).

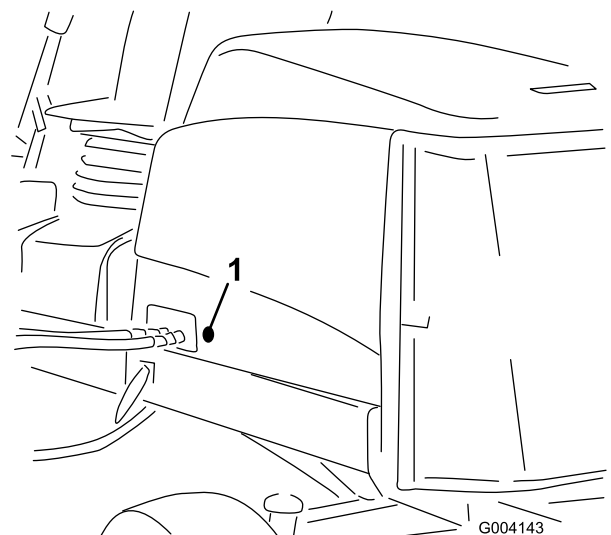

Figure 5

1. Rubber grommet

3. Remove the nut from the hood latch assembly (Figure 6).

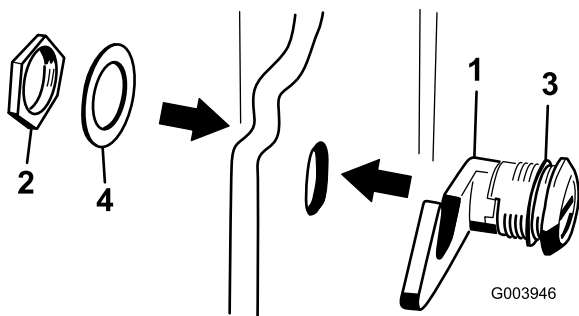

Figure 6

1. Hood latch
2. Nut
3. Rubber washer
4. Metal washer

4. Outside the hood, insert the hook end of the latch through the hole in the hood. Make sure the rubber sealing washer remains to the outer side of the hood.
5. Inside the hood, insert the metal washer onto the latch and secure with the nut. Make sure the latch engages the frame catch when it is locked. Use the enclosed hood latch key to operate the hood latch.

7

Installing the Throttle Stop for CE Compliance

Parts needed for this procedure:

1	Throttle stop
1	Set screw

Procedure

1. Loosen the set screw on the throttle stop (Figure 7).
2. Slide the throttle stop onto the high idle stop screw (Figure 7). The chamfered end of the throttle stop is to be positioned outward.

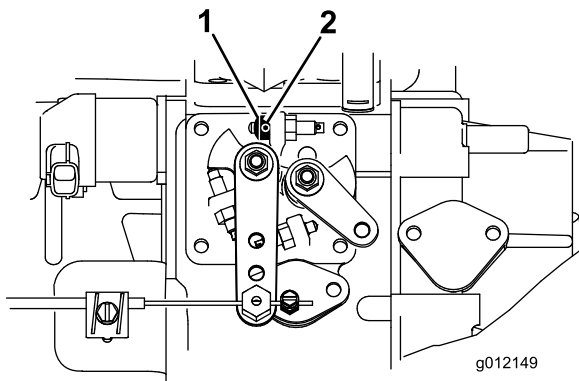

Figure 7

1. Throttle stop
2. Set screw

3. Start the engine and allow it to run for 5 to 10 minutes.
4. Adjust the high idle to 2860 rpm with the cutting decks disengaged.
5. Tighten the set screw.
6. Apply adhesive into the set screw to prevent tampering.

8

Adjusting the Carrier Frame

No Parts Required

Adjusting the Front Cutting Decks

The front and rear cutting decks require different mounting positions. The front cutting deck has two mounting positions depending on what height-of-cut and degree of deck rotation you desire.

1. For heights of cut in the 2 to 7.6 cm (3/4 to 3 inch) range, mount the front carrier frames in the lower front mounting holes (Figure 8).

Note: This permits more up travel of the cutting decks relative to tractor when approaching quick uphill changes in terrain. It does however limit the clearance of the chamber to the carrier when cresting sharp knolls.

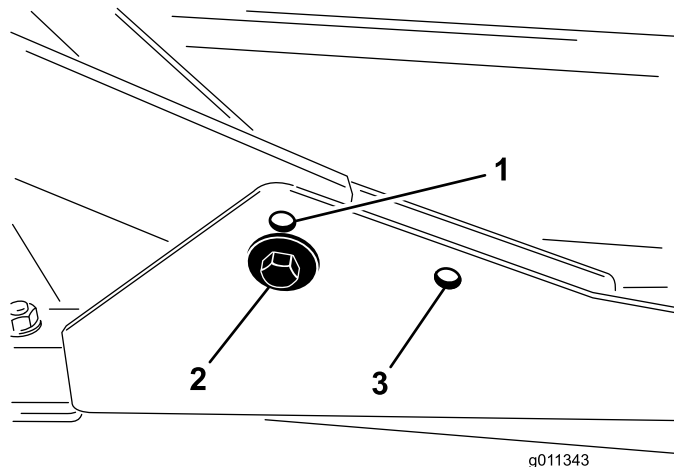

Figure 8

1. Front deck mounting hole (upper)
2. Front deck mounting hole (lower)
3. Rear deck mounting hole (upper)

2. For heights of cut in the 6.3 to 10 cm (2-1/2 to 4 inch) range, mount the front carrier frames in the upper front mounting holes (Figure 8).

Note: This increases the chamber to carrier clearance due to the higher position of the cutting chamber, but

will cause the cutting deck to reach their maximum up travel sooner.

Adjusting the Rear Cutting Deck

The front and rear cutting decks require different mounting positions. The rear cutting deck has one mounting position for proper alignment with the sidewinder under frame.

For all heights of cut, mount the rear cutting deck in the rear mounting holes (Figure 8).

9

Adjusting the Height-of-Cut

No Parts Required

Procedure

Important: This cutting deck often cuts approximately 6 mm (1/4 inch) lower than a reel cutting unit with the same bench setting. It may be necessary to have these rotary cutting deck's bench set 6 mm (1/4 inch) above that of reels cutting in the same area.

Important: Access to the rear cutting units is greatly improved by removing the cutting unit from the tractor. If the unit is equipped with a Sidewinder®, sidewind the cutting units to the right, remove the rear cutting unit, and slide it out to the right side.

1. Lower the cutting deck to the ground, stop the engine, and remove the key from ignition switch.
2. Loosen the bolt securing each height-of-cut bracket to the height-of-cut plate (front and each side) (Figure 9).
3. Beginning with front adjustment, remove the bolt.

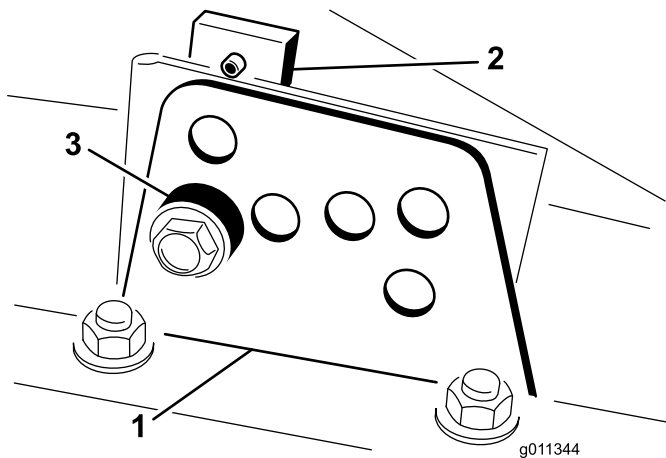

Figure 9

1. Height of cut bracket
2. Height of cut plate
3. Spacer

4. While supporting the chamber, remove the spacer (Figure 10).
5. Move the chamber to the desired height-of-cut and install a spacer into the designated height-of-cut hole and slot (Figure 10).

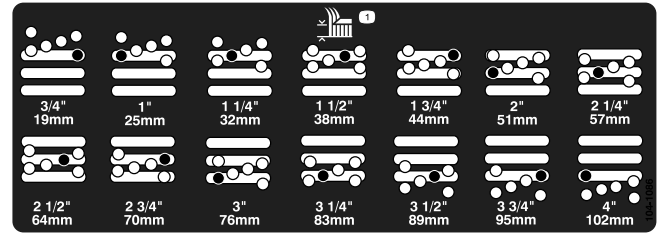

Figure 10

6. Position the tapped plate in line with the spacer.
7. Install the bolt finger tight.
8. Repeat steps 4-7 for each side adjustment.
9. Tighten all three bolts to 41 N-m (30 ft-lb). Always tighten the front bolt first.

Note: Adjustments of more than 3.8 cm (1-1/2 inches) may require temporary assembly to an intermediate height to prevent binding (e.g. changing from 3.1 to 7 cm (1.25 to 2.75 inch) height-of-cut).

10

Adjusting the Roller Scraper (Optional)

No Parts Required

Procedure

The optional rear roller scraper is designed to work best when there is an even gap of 0.5 to 1 mm (0.020–0.040 inch) between the scraper and roller.

1. Loosen the grease fitting and the mounting screw (Figure 11).

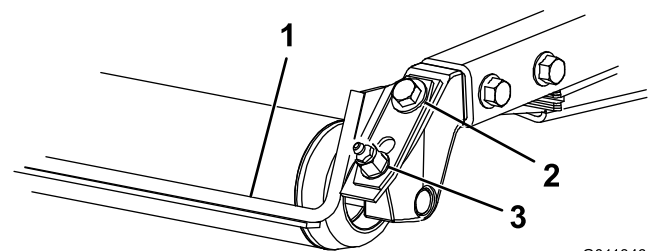

Figure 11

1. Roller scraper
2. Mounting screw
3. Grease fitting

- Slide the scraper up or down until a gap of 0.5 to 1 mm (0.020 to 0.040 inch) is achieved between the rod and the roller.
- Secure the grease fitting and screw to 41 N-m (30 ft-lb) in an alternating sequence.

11

Installing the Mulching Baffle (Optional)

No Parts Required

Procedure

- Thoroughly clean debris from the mounting holes on the rear wall and left side wall of the chamber.
- Install the mulching baffle in the rear opening and secure it with 5 flange head bolts (Figure 12).

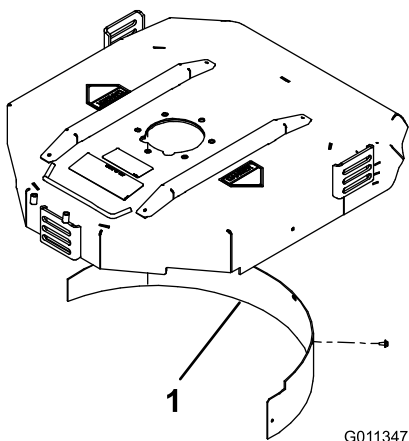

Figure 12

- Mulching baffle

- Verify that mulching baffle does not interfere with the tip of the blade and does not protrude inside the surface of the rear chamber wall.

⚠ WARNING

Do not use the high lift blade with the mulching baffle. The blade could break, resulting in personal injury or death.

Product Overview

Controls

Seat Adjusting Knobs

The seat adjusting lever (Figure 13) allows you to adjust the seat fore and aft. The weight adjusting knob adjusts the seat for the operator's weight. The weight gauge indicates when the seat is adjusted to the weight of the operator. The height adjusting knob adjusts the seat for the operator's height.

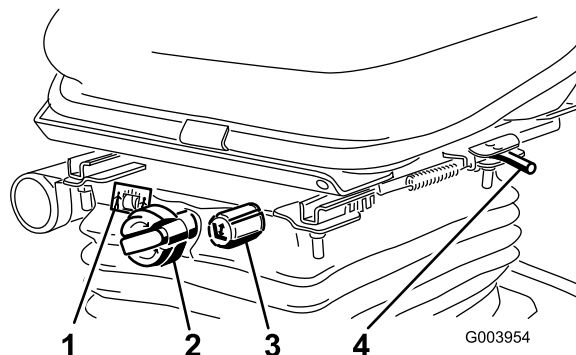

Figure 13

- | | |
|--------------------------|-----------------------------------|
| 1. Weight gauge | 3. Height adjusting knob |
| 2. Weight adjusting knob | 4. Adjusting lever (fore and aft) |

Traction Pedal

The traction pedal (Figure 14) controls the forward and reverse operation. Press the top of the pedal to move forward and the bottom to move rearward. Ground speed depends on how far you press the pedal. For no load, maximum ground speed, fully press the pedal while the throttle is in the Fast position.

To stop, reduce foot pressure on the traction pedal and allow it to return to the center position.

Mow Speed Limiter

When the mow speed limiter (Figure 14) is flipped up it will control the mow speed and allow the cutting decks to be engaged. Each spacer adjusts the mowing speed by 1/2 mile per hour. The more spacers you have, on the top of the bolt the slower you will go. For transport, flip back the mow speed limiter and you will have maximum transport speed.

Brake Pedal

Press the brake pedal (Figure 14) to stop the machine.

Parking Brake

To engage the parking brake, (Figure 14) push down on the brake pedal and press the top forward to latch. To release the

parking brake, press the brake pedal until the parking brake latch retracts.

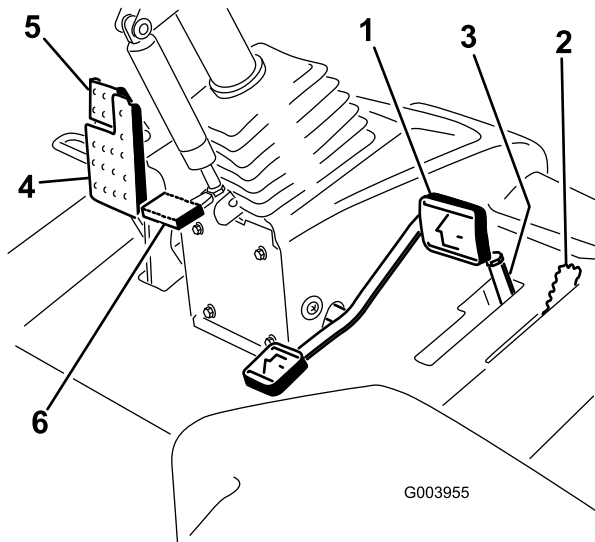

Figure 14

- | | |
|----------------------|------------------------|
| 1. Traction pedal | 4. Brake pedal |
| 2. Mow speed limiter | 5. Parking brake |
| 3. Spacers | 6. Tilt steering pedal |

Tilt Steering Pedal

To tilt the steering wheel towards you, press the foot pedal (Figure 14) down, and pull the steering tower toward you to the most comfortable position and then release the pedal.

Headlight Switch

Pivot the switch downward to turn on the headlights (Figure 15).

Throttle Control

Move the throttle control (Figure 15) forward to increase the engine speed and rearward to decrease speed.

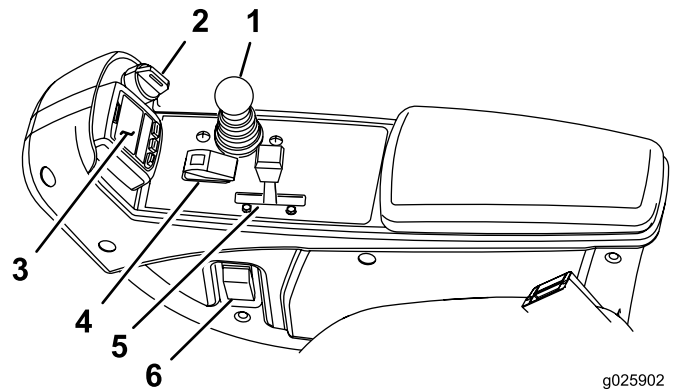

Figure 15

- | | |
|----------------------------------|--------------------------------|
| 1. Lower mow/raise control lever | 4. Enable/disable switch lever |
| 2. Key switch | 5. Throttle control |
| 3. InfoCenter | 6. Headlight switch |

Key Switch

The key switch (Figure 15) has three positions: Off, On/Preheat, and Start.

Lower Mow/Raise Control Lever

This lever (Figure 15) raises and lowers the cutting decks and also starts and stops the mowers when the mowers are enabled in the mow mode. When starting the decks in the down position, this lever will turn the decks on if the PTO and the mow speed limiter are engaged.

Enable/Disable Switch

Use the enable/disable switch (Figure 15) in conjunction with the lower mow/raise control lever to operate the mowers. The mowers cannot be lowered when the mow/transport lever is in the transport position.

InfoCenter

The InfoCenter LCD display shows information about your machine such as the operating status, various diagnostics and other information about the machine (Figure 15).

Hydraulic Filter Restriction Indicator

With the engine running at normal operating temperature, view the indicator (Figure 16), it should be in the Green zone. When the indicator is in the Red zone, change the hydraulic filters.

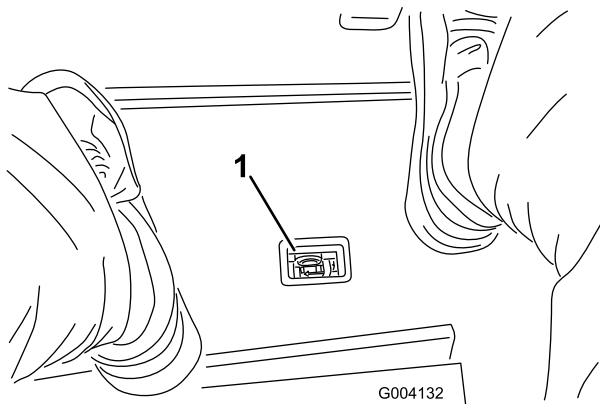

Figure 16

1. Hydraulic filter restriction indicator

Power Point

The power point is a 12 volt power supply for electronic devices (Figure 17).

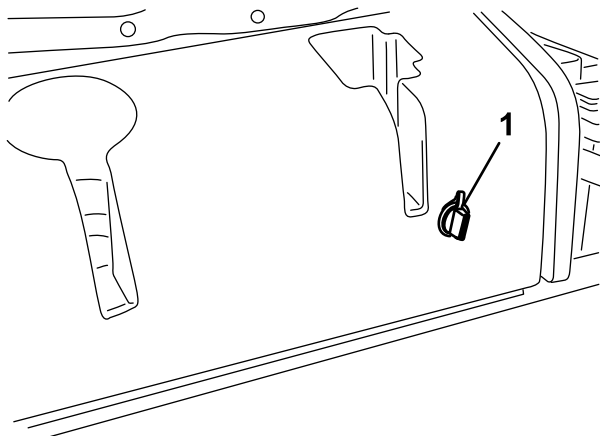

Figure 17

1. Power point

Using the InfoCenter LCD Display

The InfoCenter LCD display shows information about your machine such as the operating status, various diagnostics and other information about the machine (Figure 18). There is a splash screen and main information screen of the InfoCenter. You can switch between the splash screen and main information screen, at any time, by pressing any of the InfoCenter buttons and then selecting the appropriate directional arrow.

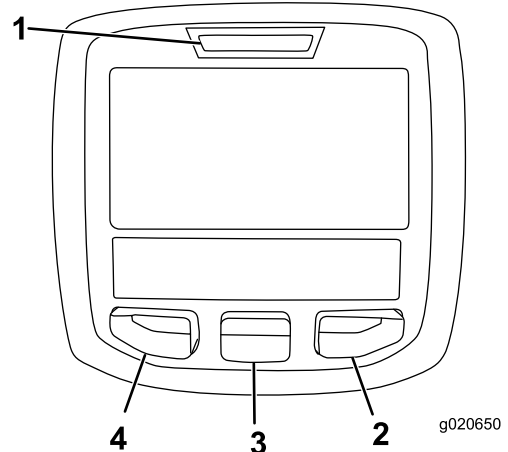







Figure 18

1. Indicator light
2. Right button
3. Middle button
4. Left button

















- Left Button, Menu Access/Back Button—press this button to access the InfoCenter menus. You can use it to back out of any menu you are currently using.
- Middle Button—use this button to scroll down menus.
- Right Button—use this button to open a menu where a right arrow indicates additional content.

Note: The purpose of each button may change depending on what is required at the time. Each button will be labeled with an icon displaying its current function.









InfoCenter Icon Description

SERVICE DUE	Indicates when scheduled service should be performed
	Hour meter
	Info icon
	Fast
	Slow
	Fuel level

InfoCenter Icon Description (cont'd.)

	Glow plugs are active
	Raise cutting units
	Lower cutting units
	Operator must sit in seat
	Parking Brake Indicator—indicates when the parking brake is On
H	Identifies the range as High (Transport)
N	Neutral
L	Identifies the range as Low (Mow)
	Coolant Temperature—indicates the engine coolant temperature in either °C or °F
	Temperature (hot)
	PTO is engaged
	Denied or not allowed
	Engine Start
	Stop or shutdown
	Engine
	Key switch
	Indicates when the cutting units are being lowered
	Indicates when the cutting units are being raised
PIN	PIN passcode
CAN	CAN bus
	InfoCenter
Bad	Bad or failed

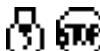
InfoCenter Icon Description (cont'd.)

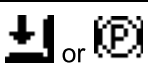
	Bulb
OUT	Output of TEC controller or control wire in harness
	Switch
	Operator must release switch
	Operator should change to indicated state
Symbols are often combined to form sentences. Some examples are shown below	
	Operator should put machine in neutral
	Engine start denied
	Engine shutdown
	Engine coolant too hot
	Sit down or set parking brake

Using the Menus

To access the InfoCenter menu system, press the menu access button while at the main screen. This will bring you to the main menu. Refer to the following tables for a synopsis of the options available from the menus:

Main Menu	
Menu Item	Description
Faults	The Faults menu contains a list of the recent machine faults. Refer to the Service Manual or your Authorized Toro Distributor for more information on the Faults menu and the information contained there.
Service	The Service menu contains information on the machine such as hours of use, counters, and other similar numbers.

Diagnostics	The Diagnostics menu displays the state of each machine switch, sensor, and control output. You can use this to troubleshoot certain issues as it will quickly tell you which machine controls are on and which are off.
Settings	The Settings menu allows you to customize and modify configuration variables on the InfoCenter display.
About	The About menu lists the model number, serial number, and software version of your machine.

Service	
Menu Item	Description
Hours	Lists the total number of hours that the machine, engine and PTO have been on, as well as the number of hours the machine has been transported and service due.
Counts	Lists numerous counts the machine has experienced.

Diagnostics	
Menu Item	Description
Cutting Units	Indicates the inputs, qualifiers, and outputs for raising and lowering the cutting units.
Hi/Low Range	Indicates the inputs, qualifiers, and outputs for driving in transport mode.
PTO	Indicates the inputs, qualifiers, and outputs for enabling the PTO circuit.
Engine Run	Indicates the inputs, qualifiers, and outputs for starting the engine.

Settings	
Menu Item	Description
Units	Controls the units used on the InfoCenter. The menu choices are English or Metric
Language	Controls the language used on the InfoCenter*.
LCD Backlight	Controls the brightness of the LCD display.
LCD Contrast	Controls the contrast of the LCD display.

Protected Menu	Allows the superintendent/mechanic to access protected menus by inputting a passcode.
Counterbalance	Controls the amount of counterbalance applied to the cutting decks.

* Only "operator-faced" text is translated. Faults, Service, and Diagnostics screens are "service-faced". Titles will be in the selected language, but menu items are in English.

About	
Menu Item	Description
Model	Lists the model number of the machine.
SN	Lists the serial number of the machine.
Machine Controller Revision	Lists the software revision of the master controller.
InfoCenter Revision	Lists the software revision of the InfoCenter.
CAN Bus	Lists the machine communication bus status.

Protected Menu

There is 1 operating configuration setting that is adjustable within the Settings Menu of the InfoCenter: counterbalance. This setting can be locked by using the Protected Menu.

Note: At the time of delivery, the initial password code is programmed by your distributor.

Accessing the Protected Menu Settings

To access the Protected Menu Settings

- From the Main Menu, scroll down to the Settings Menu and press the right button.
- In the Settings Menu, scroll down to the Protected Menu and press the right button.
- To enter the passcode, use the center button to set the first digit then press the right button to move on to the next digit.
- Use the center button to set the second digit then press the right button to move on to the next digit.
- Use the center button to set the third digit then press the right button to move on to the next digit.
- Use the center button to set the fourth digit then press the right button.
- Press the middle button to enter the code.
- If the code has been accepted and the protected menu has been "Unlocked", "PIN" will be displayed in the upper right corner of the display screen.

The ability to view and change the settings in the Protected Menu can be changed. Once the Protected Menu has been

accessed, scroll down to Protect Settings. Using the right button, changing Protect Settings to OFF will allow the ability to view and change the settings in the Protected Menu without entering the passcode. Changing Protect Settings to ON will hide the protected options and will require entering a passcode to change the setting in the Protected Menu. After the pass code has been set, the key switch must be turned off and back on to enable and save this feature.

Note: If the passcode has been forgotten or misplaced, please contact your distributor for assistance.

To Set the Counterbalance

- In the Settings Menu, scroll down to Counterbalance.
- Press the right button to select counterbalance and change between the low, medium, and high settings.

Specifications

Note: Specifications and design are subject to change without notice.

Transport Width	226 cm (89 inches)
Width of cut	229 cm (90 inches)
Length	320 cm (126 inches)
Height	218 cm (86 inches)
Net weight*	1,412 kg (3,114 lb)
Fuel tank capacity	53 liters (14 US gallons)
Transport speed	0–16 kph (0–10 mph)
Mowing speed	0–13 kph (0–8 mph)
* With cutting decks and fluids	

Cutting Deck	
Length	86.4 cm (34 inches)
Width	86.4 cm (34 inches)
Height	24.4 cm (9.6 inches) to carrier mount 26.7 cm (10–1/2 inches) at 3/4 inch height of cut 34.9 cm (13–3/4 inches) at 4 inch height of cut
Weight	88 kg (195 pounds)

Attachments/Accessories

A selection of Toro approved attachments and accessories is available for use with the machine to enhance and expand its capabilities. Contact your Authorized Service Dealer or Distributor or go to www.Toro.com for a list of all approved attachments and accessories.

Operation

Note: Determine the left and right sides of the machine from the normal operating position.

⚠ CAUTION

If you leave the key in the ignition switch, someone could accidentally start the engine and seriously injure you or other bystanders.

Lower the cutting decks to the ground, set the parking brake and remove the key from the ignition switch before servicing or making adjustments to the machine.

Checking the Engine Oil Level

The engine is shipped with oil in the crankcase; however, the oil level must be checked before and after the engine is first started.

Crankcase capacity is approximately 5.2 liters (5.5 quarts) with the filter.

Use high-quality engine oil that meets the following specifications:

- API Classification Level Required: CH-4, CI-4 or higher
- Preferred oil: SAE 15W-40 (above 0 degrees F)
- Alternate oil: SAE 10W-30 or 5W-30 (all temperatures)

Toro Premium Engine oil is available from your distributor in either 15W-40 or 10W-30 viscosity.

1. Park the machine on a level surface, stop the engine, set the parking brake and remove the key from the ignition switch.
2. Open the hood.
3. Remove the dipstick, wipe it clean, and install it (Figure 19).

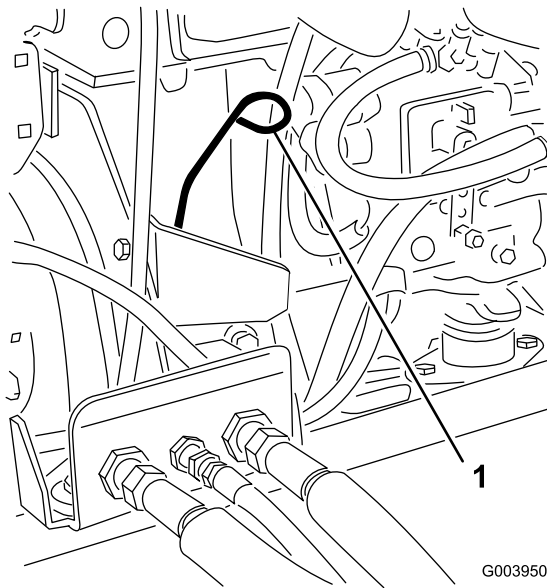

Figure 19

G003950

1. Dipstick

4. Remove dipstick and check oil level on dipstick.

The oil level should be up to the Full mark .

5. If the oil level is below the Full mark, remove the fill cap (Figure 20) and add oil until level reaches the Full mark on dipstick.

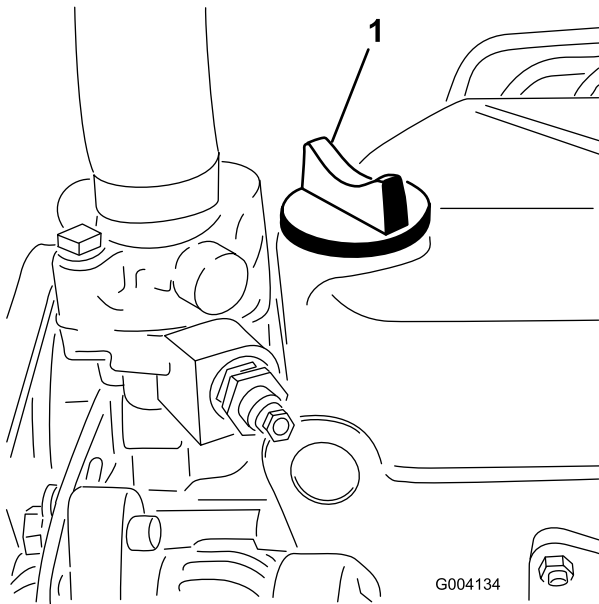

Figure 20

G004134

1. Oil fill cap

Do not overfill.

Important: Be sure to keep the engine oil level between the upper and lower limits on the oil gauge. Engine failure may occur as a result of over filling or under filling the engine oil.

6. Install the oil fill cap and close the hood.

Checking the Cooling System

Clean debris off of the screen, oil cooler, and front of the radiator daily and more often if conditions are extremely dusty and dirty. Refer to the section on Removing Debris from the Cooling System in Maintenance.

The cooling system is filled with a 50/50 solution of water and permanent ethylene glycol antifreeze. Check the level of coolant in the expansion tank at the beginning of each day before starting the engine. The capacity of the cooling system is 9.5 liters (10.0 quarts).

⚠ CAUTION

If the engine has been running, the pressurized, hot coolant can escape and cause burns.

- Do not open the radiator cap when the engine is running.
- Use a rag when opening the radiator cap, and open the cap slowly to allow steam to escape.

1. Check the level of coolant in the expansion tank (Figure 21).

The coolant level should be between the marks on the side of the tank.

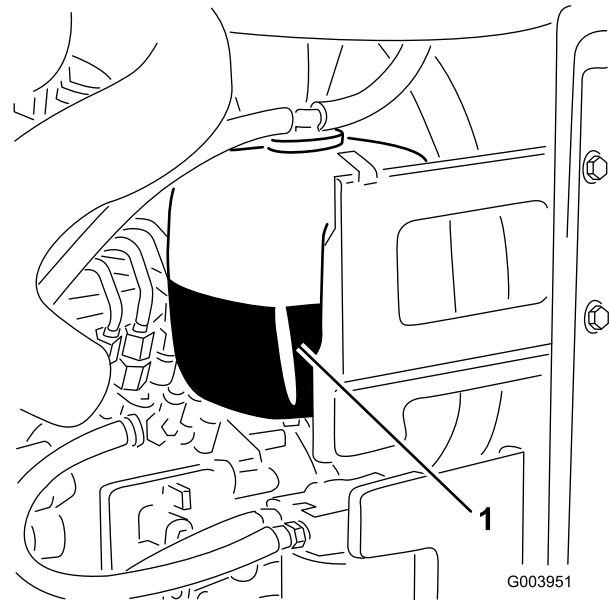

Figure 21

G003951

1. Expansion tank

2. If the coolant level is low, remove the expansion tank cap and replenish the system. **Do not overfill.**
3. Install the expansion tank cap.

Adding Fuel

Use only clean, fresh diesel fuel or biodiesel fuels with low (<500 ppm) or ultra low (<15 ppm) sulfur content. The minimum cetane rating should be 40. Purchase fuel in quantities that can be used within 180 days to ensure fuel freshness.

Fuel tank capacity: 53 liters (14 gallons)

Use summer grade diesel fuel (No. 2-D) at temperatures above 20° F (-7° C) and winter grade (No. 1-D or No. 1-D/2-D blend) below that temperature. Use of winter grade fuel at lower temperatures provides lower flash point and cold flow characteristics which will ease starting and reduce fuel filter plugging.

Use of summer grade fuel above -7° C (20° F) will contribute toward longer fuel pump life and increased power compared to winter grade fuel.

Important: Do not use kerosene or gasoline instead of diesel fuel. Failure to observe this caution will damage the engine.

⚠ WARNING

Fuel is harmful or fatal if swallowed. Long-term exposure to vapors can cause serious injury and illness.

- Avoid prolonged breathing of vapors.
- Keep face away from nozzle and gas tank or conditioner opening.
- Keep fuel away from eyes and skin.

Biodiesel Ready

This machine can also use a biodiesel blended fuel of up to B20 (20% biodiesel, 80% petrodiesel). The petrodiesel portion should be low or ultra low sulfur. Observe the following precautions:

- The biodiesel portion of the fuel must meet specification ASTM D6751 or EN14214.
- The blended fuel composition should meet ASTM D975 or EN590.
- Painted surfaces may be damaged by biodiesel blends.
- Use B5 (biodiesel content of 5%) or lesser blends in cold weather.
- Monitor seals, hoses, gaskets in contact with fuel as they may be degraded over time.
- Fuel filter plugging may be expected for a time after converting to biodiesel blended.
- Contact your distributor if you wish for more information on biodiesel.

⚠ DANGER

In certain conditions, fuel is extremely flammable and highly explosive. A fire or explosion from fuel can burn you and others and can damage property.

- Fill the fuel tank outdoors, in an open area, when the engine is cold. Wipe up any fuel that spills.
- Never fill the fuel tank inside an enclosed trailer.
- Never smoke when handling fuel, and stay away from an open flame or where fuel fumes may be ignited by a spark.
- Store fuel in an approved container and keep it out of the reach of children. Never buy more than a 180-day supply of fuel.
- Do not operate without entire exhaust system in place and in proper working condition.

⚠ DANGER

In certain conditions during fueling, static electricity can be released causing a spark which can ignite the fuel vapors. A fire or explosion from fuel can burn you and others and can damage property.

- Always place fuel containers on the ground away from your vehicle before filling.
- Do not fill fuel containers inside a vehicle or on a truck or trailer bed because interior carpets or plastic truck bed liners may insulate the container and slow the loss of any static charge.
- When practical, remove equipment from the truck or trailer and refuel the equipment with its wheels on the ground.
- If this is not possible, then refuel such equipment on a truck or trailer from a portable container, rather than from a fuel dispenser nozzle.
- If a fuel dispenser nozzle must be used, keep the nozzle in contact with the rim of the fuel tank or container opening at all times until fueling is complete.
 1. Park the machine on a level surface.
 2. Using a clean rag, clean area around fuel tank cap.
 3. Remove the cap from the fuel tank (Figure 22).

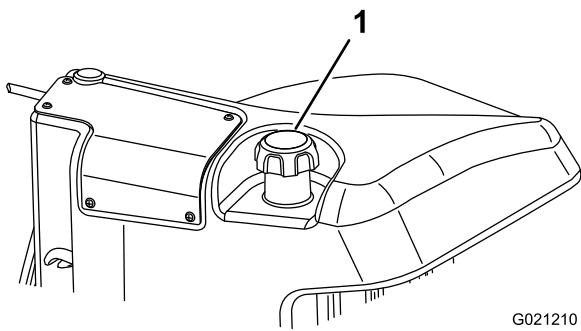

Figure 22

G021210

1. Fuel tank cap

4. Fill the tank until the level is to the bottom of the filler neck with diesel fuel.
5. Install the fuel tank cap tightly after filling the tank.

Note: If possible, fill the fuel tank after each use. This will minimize possible buildup of condensation inside the fuel tank.

Checking the Hydraulic Fluid

The machine's reservoir is filled at the factory with approximately 56.7 liters (15 U.S. gallons) of high quality hydraulic fluid. Check the level of the hydraulic fluid before the engine is first started and daily thereafter. The recommended replacement fluid is as follows:

Toro Premium All Season Hydraulic Fluid (Available in 5 gallon pails or 55 gallon drums. See parts catalog or Toro distributor for part numbers.)

Alternate fluids: If the Toro fluid is not available, other fluids may be used provided they meet all the following material properties and industry specifications. We do not recommend the use of synthetic fluid. Consult with your lubricant distributor to identify a satisfactory product. Note: Toro will not assume responsibility for damage caused by improper substitutions, so use only products from reputable manufacturers who will stand behind their recommendation.

High Viscosity Index/Low Pour Point Anti-wear Hydraulic Fluid, ISO VG 46

Material Properties:

Viscosity, ASTM D445	cSt @ 40°C 44 to 48cSt @ 100°C 7.9 to 8.5
Viscosity Index ASTM D2270	140 to 160
Pour Point, ASTM D97	-34°F to -49°F

Industry Specifications:

Vickers I-286-S (Quality Level), Vickers M-2950-S (Quality Level), Denison HF-0

Important: The ISO VG 46 Multigrade fluid has been found to offer optimal performance in a wide range of

temperature conditions. For operation in consistently high ambient temperatures, 65° F (18° C) to 120° F (49° C), ISO VG 68 hydraulic fluid may offer improved performance.

Premium Biodegradable Hydraulic Fluid-Mobil EAL EnviroSyn 46H

Important: Mobil EAL EnviroSyn 46H is the only synthetic biodegradable fluid approved by Toro. This fluid is compatible with the elastomers used in Toro hydraulic systems and is suitable for a wide-range of temperature conditions. This fluid is compatible with conventional mineral oils, but for maximum biodegradability and performance the hydraulic system should be thoroughly flushed of conventional fluid. The oil is available in 19 liters (5 gallon) containers or 55 gallon drums from your Mobil Distributor.

Important: Many hydraulic fluids are almost colorless, making it difficult to spot leaks. A red dye additive for the hydraulic system oil is available in 2/3 oz. (20 ml) bottles. One bottle is sufficient for 4-6 gal (15-22 l) of hydraulic oil. Order part no. 44-2500 from your authorized Toro distributor.

1. Position machine on a level surface, lower the cutting decks and stop the engine.
2. Clean area around filler neck and cap of hydraulic tank (Figure 23).

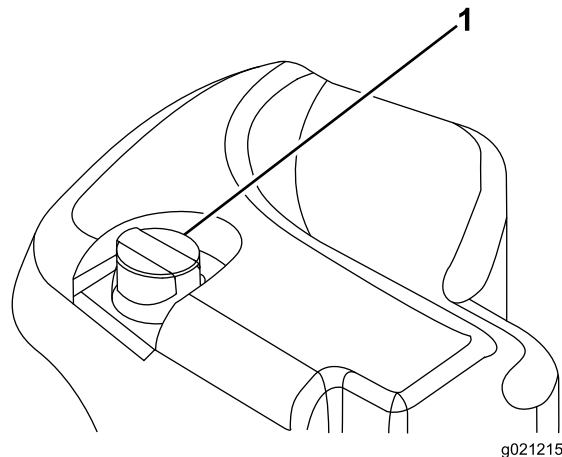

g021215

Figure 23

1. Hydraulic tank cap

3. Remove cap/dipstick from filler neck and wipe it with a clean rag. Insert dipstick into filler neck; then remove it and check level of fluid. Fluid level should be within operating range on dipstick. Do not overfill.
4. If level is low, add appropriate fluid to raise level to full mark.
5. Install cap/dipstick onto filler neck.

Check the Torque of the Wheel Nuts

Torque the wheel lug nuts to 94 to 122 N·m (70 to 90 ft-lb) after **1-4 hours** of operation and again after **10 hours** of operation. Torque every **250 hours** thereafter.

▲ WARNING

Failure to maintain proper torque of the wheel nuts could result in personal injury.

Breaking-in the Machine

To ensure optimum performance of the parking brake system, burnish (break-in) the brakes before use. Set the forward traction speed to 4 mph to match the reverse traction speed. (All eight spacers moved to the top of the mow speed control.) With the engine at high idle, proceed forward with the mow speed control stop engaged and ride the brake for 15 seconds. Proceed backwards at full reverse speed and ride the brake for 15 seconds. Repeat this 5 times waiting 1 minute between each forward and reverse cycle to avoid overheating the brakes. An adjustment to the brakes may be required after break-in; refer to Adjusting the Parking Brakes.

Bleeding the Fuel System

You must bleed the fuel system before starting the engine if any of the following situations have occurred:

- Initial start up of a new machine.
- Engine has ceased running due to lack of fuel.
- Maintenance has been performed upon fuel system components; i.e., filter replaced, separator serviced, etc.

▲ DANGER

Under certain conditions, diesel fuel and fuel vapors are highly flammable and explosive. A fire or explosion from fuel can burn you and others and can cause property damage.

- Use a funnel and fill the fuel tank outdoors, in an open area, when the engine is off and is cold. Wipe up any fuel that spills.
- Do not fill the fuel tank completely full. Add fuel to the fuel tank until the level is 6 to 13 mm (1/4 to 1/2 inches) below the bottom of the filler neck. This empty space in the tank allows the fuel to expand.
- Never smoke when handling fuel, and stay away from an open flame or where fuel fumes may be ignited by a spark.
- Store fuel in a clean, safety-approved container and keep the cap in place.

1. Park the machine on a level surface and ensure that the fuel tank is at least half full.
2. Open the hood.
3. Open the air bleed screw on the fuel injection pump (Figure 24) with a 12 mm wrench.

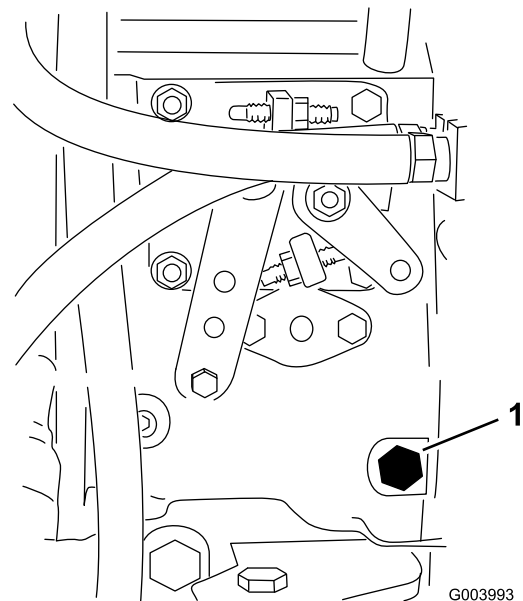

Figure 24

1. Bleed screw
4. Turn the key in the ignition switch to the On position. The electric fuel pump will begin operation, thereby forcing air out around the air bleed screw. Leave the key in the On position until a solid stream of fuel flows out around the screw.
5. Tighten the screw and turn the key to the Off position.

Note: Normally, the engine should start after the above bleeding procedures are followed. However, if engine does not start, air may be trapped between injection pump and injectors; refer to Bleeding Air from the Injectors.

Starting and Stopping the Engine

Important: You must bleed the fuel system before starting the engine if you are starting the engine for the first time, the engine has stopped due to lack of fuel, or you have performed maintenance on the fuel system; refer to Bleeding the Fuel System.

Starting the Engine

1. Sit on the seat, keep your foot off of the traction pedal so that it is in Neutral, engage the parking brake, set the throttle to the Fast position, and ensure that the Enable/Disable switch is in the Disable position.
2. Turn the ignition switch to the On/Preheat position.

An automatic timer will control the glow plug preheat for 6 seconds.

3. After preheating the glow plugs, turn key to the Start position.

Crank the engine for no longer than 15 seconds. Release the key when the engine starts. If additional preheating is required, turn key to the Off position and then to the On/Preheat position. Repeat this process as required.

4. Run the engine at low idle speed until it warms up.

Stopping the Engine

1. Move all controls to Neutral, set the parking brake, move the throttle to the low idle position and allow the engine to reach low idle speed.

Important: Allow the engine to idle for 5 minutes before shutting it off after a full load operation. Failure to do so may lead to trouble on a turbo-charged engine.

2. Turn the key to the Off position and remove it from the switch.

Pushing or Towing the Machine

In an emergency, the machine can be moved by actuating the bypass valve in the variable displacement hydraulic pump and pushing or towing the machine.

Important: Do not push or tow the machine faster than 3-4.8 km/h (2-3 mph) because internal transmission damage may occur. The bypass valve must be open whenever the machine is pushed or towed.

1. The bypass valve is located on the left side of the hydrostat (Figure 25). Rotate the bolt 1-1/2 turns to open and allow oil to bypass internally. Because fluid is bypassed, the machine can be moved slowly without damaging the transmission.

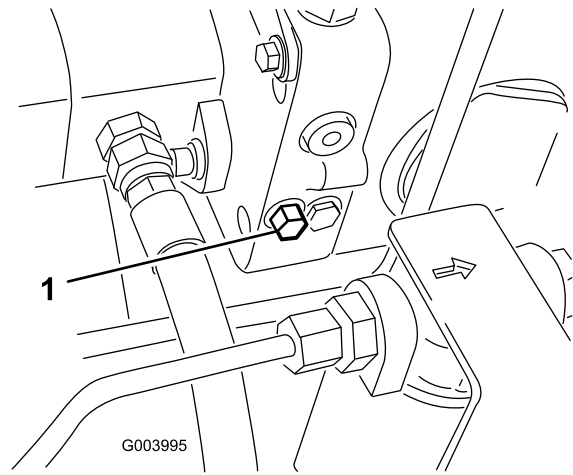

Figure 25

1. Bypass valve

2. Close the bypass valve before starting the engine. However, do not exceed 7-11 N·m (5-8 ft.-lb.) torque to close the valve.

Important: Running the engine with the bypass valve open will cause the transmission to overheat.

Jacking Points

Note: Use jack stands to support the machine when required.

- Front—rectangular pad, under the axle tube, inside each front tire (Figure 26).

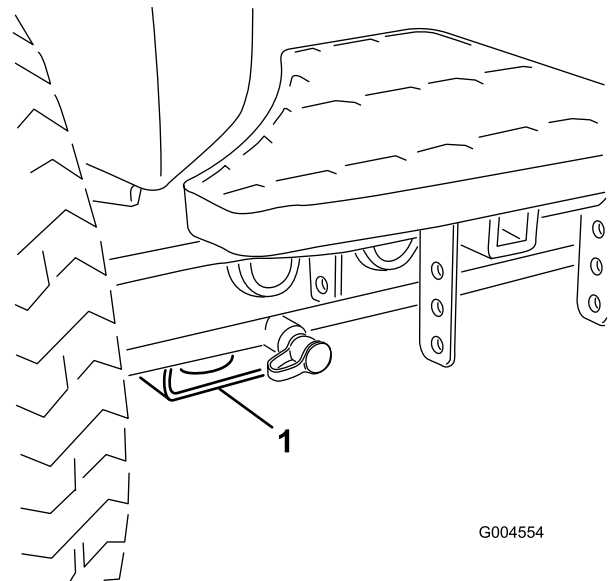

Figure 26

1. Front jacking point

- Rear—rectangular axle tube on the rear axle.

Tie Downs

- Front—the hole in the rectangular pad, under the axle tube, inside each front tire (Figure 27).

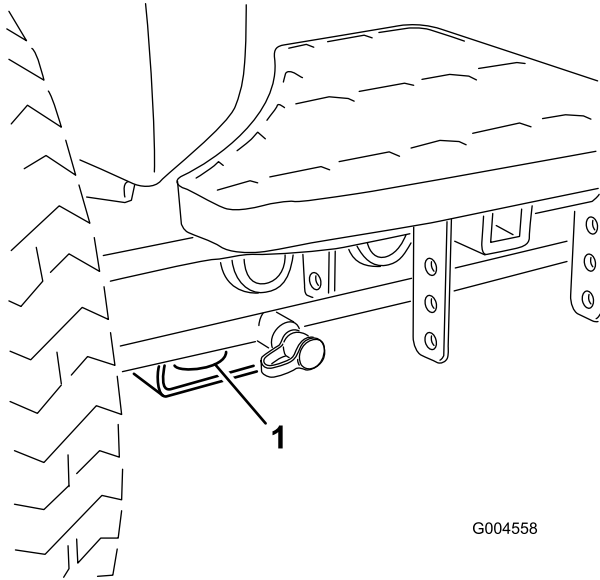

Figure 27

1. Front tie down

- Rear—each side of the machine on the rear frame (Figure 28).

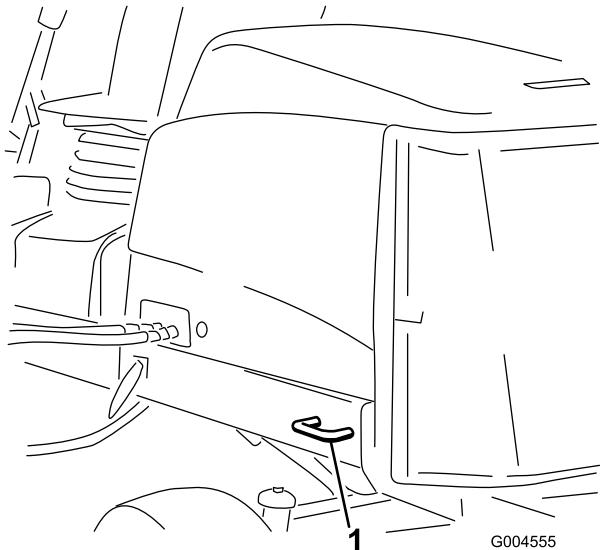

Figure 28

1. Rear tie down

Understanding the Diagnostic Light

The machine is equipped with a diagnostic light which indicates if the machine detects a malfunction. The diagnostic light is located on the InfoCenter, above the display screen (Figure 29). When the machine is functioning properly

and the key switch is moved to the On/Run position, the diagnostic light will turn on briefly to indicate the light is working properly. When a machine advisory message is displayed, the light will illuminate when the message is present. When a fault message is displayed, the light will blink until the fault is resolved.

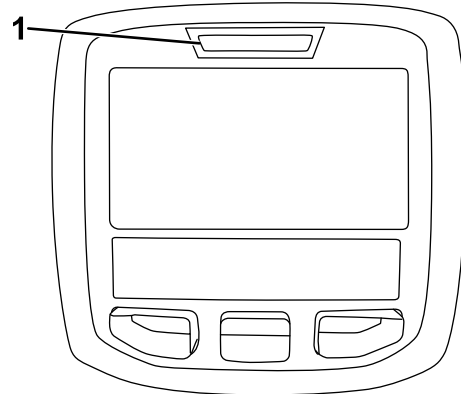

Figure 29

1. Diagnostic light

Changing the Counterbalance Settings

During different times of the mowing season or when turf conditions vary, the amount of counterbalance (upward lift) required on the cutting decks can be changed to meet the conditions.

1. Position the machine on a level surface, lower the cutting decks, stop the engine and engage the parking brake
2. Rotate the ignition key to the Run position.
3. In the InfoCenter Settings Menu, scroll down to Counterbalance.
4. Press the right button to select counterbalance and change between the low, medium, and high settings.

Note: Once the adjustment has been completed, move the machine to a test area and operate the machine with the new setting. The new counterbalanced setting may change the effective height of cut.

Checking the Interlock Switches

The purpose of the interlock switches is to prevent the engine from cranking or starting unless the traction pedal is in the Neutral position, the Enable/Disable switch is in the Disable position, and the Lower Mow/Raise control is in the Neutral position. In addition, the engine should stop when the traction pedal is pressed with operator off of the seat or if the parking brake is left engaged.

⚠ CAUTION

If safety interlock switches are disconnected or damaged the machine could operate unexpectedly causing personal injury.

- Do not tamper with the interlock switches.
- Check the operation of the interlock switches daily and replace any damaged switches before operating the machine.

Verifying the Interlock Switch Function

1. Park the machine on a level surface, lower the cutting units, stop the engine, and engage the parking brake.
2. Turn the key switch to the On position, but do not start the machine.
3. Locate the appropriate switch function in the diagnostics menu on the InfoCenter.
4. Individually, change each of the switches from open to closed (i.e., sit on seat, engage traction pedal, etc.), and note that the appropriate state of the switch changes. Repeat this for all switches that you can change by hand.
5. If a switch is closed and the appropriate indicator does not change, check all wiring and connections to the switch and/or check the switches with an ohm meter. Replace any defective switches and repair any defective wiring.

Note: The InfoCenter display also has the ability to detect which output solenoids or relays are turned on. This is a quick way to determine if a machine malfunction is electrical or hydraulic.

Verifying Output Function

1. Park the machine on a level surface, lower the cutting units, stop the engine, and engage the parking brake.
2. Turn the key switch to the On position and start the machine.
3. Locate the appropriate output function in the diagnostics menu on the InfoCenter.
4. Sit on the seat and attempt to operate the desired function of the machine. The appropriate outputs should change state to indicate that the ECM is turning on that function.

Note: If the correct outputs do not illuminate, verify that the required input switches are in the necessary positions to allow that function to occur. Verify correct switch function.

If the output displays are on as specified, but the machine does not function properly, this indicates a non-electrical problem. Repair as necessary.

Hydraulic Valve Solenoid Functions

Use the list below to identify and describe the different functions of the solenoids in the hydraulic manifold. Each solenoid must be energized to allow function to occur.

Solenoid	Function
PRV2	Front mower circuit
PRV1	Rear mower circuit
PRV	Lift/lower cutting decks
S1	Lower cutting decks
S2	Lower cutting decks

Selecting a Blade

Standard Combination Sail

This blade was designed to provide excellent lift and dispersion in almost any condition. If more or less lift and discharge velocity is required, consider a different blade.

Attributes: Excellent lift and dispersion in most conditions.

Angled Sail

The blade generally performs best in lower heights of cut - 1.9 to 6.4 cm (3/4 to 2-1/2 inch).

Attributes:

- Discharge remains more even at lower heights of cut.
- Discharge has less tendency to throw left and thus a cleaner look around bunkers and fairways.
- Lower power requirement at lower heights and dense turf.

High Lift Parallel Sail

The blade generally performs better in the higher heights of cut - 7 to 10 cm (2 to 4 inch).

Attributes:

- More lift and higher discharge velocity.
- Sparse or limp turf is picked up significantly at higher heights of cut.
- Wet or sticky clippings are discharged more efficiently reducing congestion in the deck.
- Requires more horsepower to run.
- Tends to discharge further left and can tend to windrow at lower heights of cut.

⚠ WARNING

Do not use the high lift blade with the mulching baffle. The blade could break, resulting in personal injury or death.

Atomic Blade

This blade was designed to provide excellent leaf mulching.

Attributes: Excellent leaf mulching

Choosing Accessories

Optional Equipment Configurations

	Angle Sail Blade	High Lift Parallel Sail Blade (<i>Do not use with the mulching baffle</i>)	Mulching Baffle	Roller Scraper
Grass Cutting: 1.9 to 4.4 cm (0.75 to 1.75 inch) Height-of-Cut	Recommended in most applications	May work well in light or sparse turf	Has been shown to improve dispersion and after cut performance on northern grasses that are cut at least three times per week and less than 1/3 of the grass blade is removed. Do not use with the high lift parallel sail blade	Can be used any time that rollers build up with grass or large flat grass clumps of grass are seen. The scrapers may actually increase clumping in certain applications.
Grass Cutting: 5 to 6.4 cm (2.00 to 2.50 inch) Height-of-Cut	Recommended for thick or lush turf	Recommended for light or sparse turf		
Grass Cutting: 7 to 10 cm (2.75 to 4.00 inch) Height-of-Cut	May work well in lush turf	Recommended in most applications		
Leaf Mulching	Recommended for use with the mulching baffle	Not Allowed	Use with combination sail or angle sail blade only	
Pros	Even discharge at lower height of cut Cleaner look around bunkers and fairways Lower power requirements	More lift and higher discharge velocity Sparse or limp turf is picked up at high height of cut Wet or sticky clippings are discharged efficiently	May improve dispersion and appearance in certain grass cutting applications Very good for leaf mulching	Reduces roller buildup in certain applications
Cons	Does not lift the grass well in high height of cut applications Wet or sticky grass has a tendency to build up in the chamber, leading to poor quality of cut and higher power requirements	Requires more power to run in some applications Tends to windrow at lower height of cut in lush grass Do not use with the mulching baffle	Grass will build up in the chamber if attempting to remove too much grass with baffle in place	

Operating Tips

Familiarization

Before mowing grass, practice operating the machine in an open area. Start and stop the engine. Operate in forward and reverse. Lower and raise the cutting decks and engage and disengage the mowers. When you feel familiar with the machine, practice operating up and down slopes at different speeds.

Warning System

If a warning light comes on during operation, stop the machine immediately and correct the problem before continuing operation. Serious damage could occur if you operate the machine with a malfunction.

Mowing

Start the engine and move the throttle to the Fast position. Move the Enable/Disable switch to the Enable position and use the Lower Mow/Raise lever to control the cutting decks.

To move forward and cut grass, press the traction pedal forward.

Note: Allow the engine to idle for 5 minutes before shutting it off after a full load operation. Failure to do so may lead to turbo-charger trouble.

Mow when the Grass is Dry

Mow either in the late morning to avoid the dew, which causes grass clumping, or in late afternoon to avoid the damage that can be caused by direct sunlight on the sensitive, freshly mowed grass.

Select the Proper Height-of-Cut Setting to Suit Conditions

Remove approximately one inch or no more than 1/3 of the grass blade when cutting. In exceptionally lush and dense grass you may have to raise the height-of-cut setting.

Always Start Mowing with Sharp Blades

A sharp blade cuts cleanly and without tearing or shredding the grass blades like a dull blade. Tearing and shredding causes the grass to turn brown at the edges which impairs growth and increases susceptibility to diseases. Make sure blade is in good condition and a full sail is present.

Check Condition of Deck

Make sure that the cutting chambers are in good condition. Straighten any bends in the chamber components to ensure the correct blade tip/chamber clearance.

After Operating

To ensure optimum performance, clean the underside of mower housing. If you allow residue to build up in mower housing, cutting performance will decrease.

Transport

Move the Enable/Disable switch to the Disable position and raise the cutting decks to the transport position. Move the Mow/Transport lever to the transport position. Be careful when driving between objects so you do not accidentally damage the machine or cutting decks. Use extra care when operating the machine on slopes. Drive slowly and avoid sharp turns on slopes to prevent roll overs. Lower the cutting decks when going downhill for steering control.

Maintenance

Note: Determine the left and right sides of the machine from the normal operating position.

Recommended Maintenance Schedule(s)

Maintenance Service Interval	Maintenance Procedure
After the first hour	<ul style="list-style-type: none"> • Torque the wheel lug nuts to 94 to 122 N·m (70 to 90 ft-lb).
After the first 8 hours	<ul style="list-style-type: none"> • Check the condition and tension of the alternator belt.
After the first 10 hours	<ul style="list-style-type: none"> • Torque the wheel lug nuts to 94 to 122 N·m (70 to 90 ft-lb).
After the first 50 hours	<ul style="list-style-type: none"> • Change the engine oil and filter. • Check the engine RPM (idle and full throttle).
Before each use or daily	<ul style="list-style-type: none"> • Check the engine oil level. • Check the cooling system. • Check the hydraulic fluid level. • Check the operation of the interlock switches. • Remove debris from the screen, oil coolers, and radiator (more frequently in dirty operating conditions). • Check the hydraulic lines and hoses for leaks, kinked lines, loose mounting supports, wear, loose fittings, weather deterioration, and chemical deterioration. • Check the blade stopping time
Every 50 hours	<ul style="list-style-type: none"> • Grease the bearings and bushings. (Grease them immediately after every washing regardless of the interval listed.) • Check the condition of and clean the battery. • Check the battery cable connections.
Every 100 hours	<ul style="list-style-type: none"> • Inspect the cooling system hoses. • Check the condition and tension of the alternator belt.
Every 150 hours	<ul style="list-style-type: none"> • Change the engine oil and filter.
Every 200 hours	<ul style="list-style-type: none"> • Drain moisture from the fuel and hydraulic fluid tanks.
Every 250 hours	<ul style="list-style-type: none"> • Torque the wheel lug nuts to 94 to 122 N·m (70 to 90 ft-lb).
Every 400 hours	<ul style="list-style-type: none"> • Service the air cleaner. (Service the air cleaner earlier if the air cleaner indicator shows red. Service it more frequently in extremely dirty or dusty conditions.) • Check the fuel lines and connections for deterioration, damage, or loose connections. • Replace the fuel filter canister. • Check the engine RPM (idle and full throttle).
Every 800 hours	<ul style="list-style-type: none"> • Drain and clean the fuel tank • Check the rear wheel toe-in. • Change the hydraulic fluid. • Change the hydraulic filters (sooner if the service interval indicator is in the Red zone). • Adjust the engine valves (refer to the engine Operator's Manual)
Before storage	<ul style="list-style-type: none"> • Drain and clean the fuel tank
Every 2 years	<ul style="list-style-type: none"> • Flush and replace the cooling system fluid. • Drain and flush the hydraulic tank. • Replace all moving hoses.

Daily Maintenance Checklist

Duplicate this page for routine use.

Maintenance Check Item	For the week of:						
	Mon.	Tues.	Wed.	Thurs.	Fri.	Sat.	Sun.
Check the safety interlock operation.							
Check the brake operation.							
Check the engine oil and fuel level.							
Drain the water/fuel separator.							
Check the air filter restriction indicator.							
Check the radiator and screen for debris.							
Check unusual engine noises. ¹							
Check unusual operating noises.							
Check the hydraulic system oil level.							
Check the hydraulic filter indicator. ²							
Check hydraulic hoses for damage.							
Check for fluid leaks.							
Check the tire pressure.							
Check the instrument operation.							
Check the Height of Cut adjustment							
Check Condition of Blades							
Check all grease fittings for lubrication. ³							
Touch-up damaged paint.							
<p>1. Check the glow plug and injector nozzles if hard starting, excess smoke, or rough running is noted.</p> <p>2. Check with the engine running and the oil at operating temperature</p> <p>3. Immediately after every washing, regardless of the interval listed</p>							

Notation for Areas of Concern

Inspection performed by:		
Item	Date	Information
1		
2		
3		
4		
5		
6		
7		
8		

Important: Refer to your *Engine Operator's Manual* for additional maintenance procedures.

Note: Looking for an *Electrical Schematic* or *Hydraulic Schematic* for your machine? Download a free copy of the schematic by visiting www.Toro.com and searching for your machine from the Manuals link on the home page.

Service Interval Chart

REELMASTER 5410 / 5510 / 5610 & GROUNDMASTER 4300
QUICK REFERENCE AID

CHECK/SERVICE (daily)

1. OIL LEVEL, ENGINE	6. RADIATOR SCREEN
2. OIL LEVEL, HYDRAULIC TANK	7. BRAKE FUNCTION
3. COOLANT LEVEL, RADIATOR	8. TIRE PRESSURE
4. FUEL /WATER SEPARATOR	9. BATTERY
5. PRECLEANER – AIR CLEANER	10. BELTS (FAN, ALT.)
	GREASING -- SEE OPERATOR'S MANUAL

FLUID SPECIFICATIONS/CHANGE INTERVALS

SEE OPERATOR'S MANUAL FOR INITIAL CHANGES.	FLUID TYPE	CAPACITY	CHANGE INTERVAL		FILTER PART NO.
			FLUID	FILTER	
A. ENGINE OIL	SAE 15W-40CI-4	5.5 QTS.	150 HRS.	150 HRS.	104-5167
B. HYD. CIRCUIT OIL	ISO VG 46/68	15 GALS.*	800 HRS.	SEE INDICATOR	94-2621
				800 HRS.	86-3010
C. AIR CLEANER				SEE INDICATOR	108-3810 (5410) (5510) 108-3812 (5610) (4300)
D. WATER SEPARATOR				400 HRS.	110-9049
E. FUEL TANK	NO. 2-DIESEL	14 GALS.	DRAIN AND FLUSH, 2 YRS.		
F. COOLANT	50/50 ETHYLENE GLYCOL/WATER	7.0 QTS. (5410) (5510)	DRAIN AND FLUSH, 2 YRS.		
		10.0 QTS. (5610) (4300)			

* INCLUDING FILTER

125-8753

Figure 30

CAUTION

If you leave the key in the ignition switch, someone could accidentally start the engine and seriously injure you or other bystanders.

Remove the key from the ignition before you do any maintenance.

Lubrication

Greasing the Bearings and Bushings

If you operate the machine under normal conditions, lubricate all grease fittings for the bearings and bushings after **every 50 hours of operation** with No. 2 General Purpose Lithium Base Grease. Lubricate bearings and bushings **immediately** after every washing, regardless of the interval listed.

The grease fitting locations and quantities are as follows:

- Pump drive shaft U-joint (3) (Figure 31)

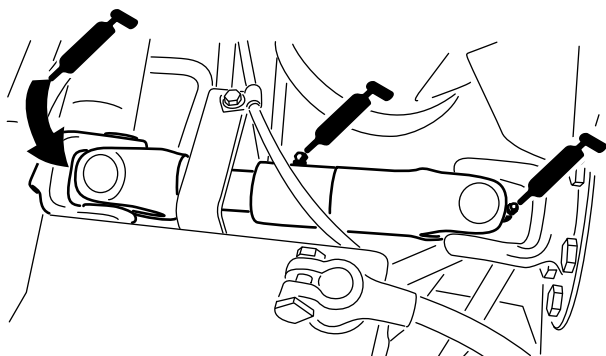
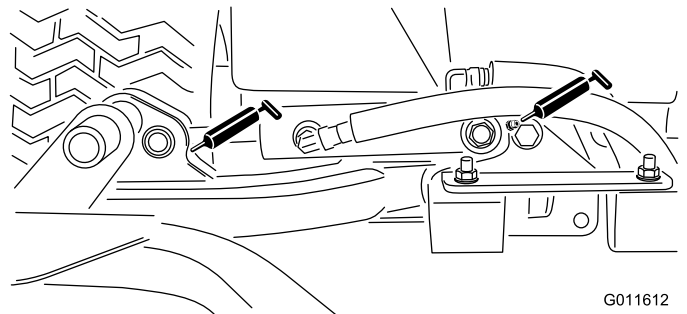

Figure 31



G011612

Figure 32

- Cutting unit lift arm cylinders (2 each) (Figure 32)

- Lift arm pivots (1 each) (Figure 32)
- Cutting unit carrier frame pivot (1 each) (Figure 33)

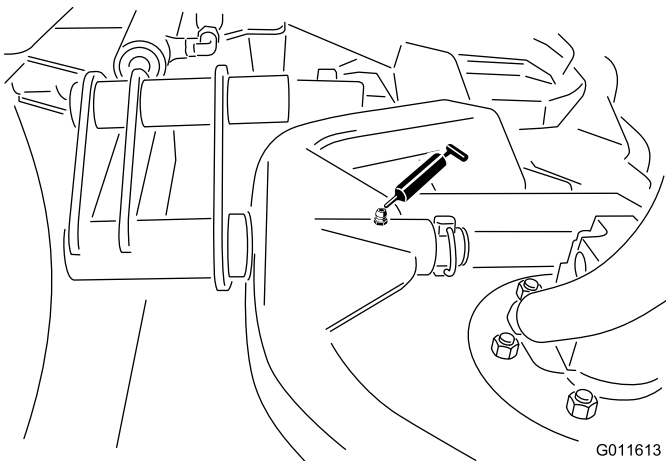

Figure 33

G011613

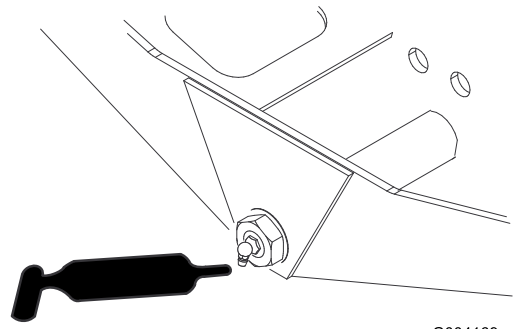
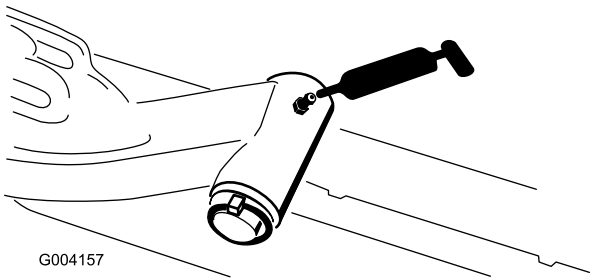

Figure 36

G004169

- Lift arm pivot shaft (1 each) (Figure 34)



G004157

Figure 34

- Rear axle tie rod (2) (Figure 35)

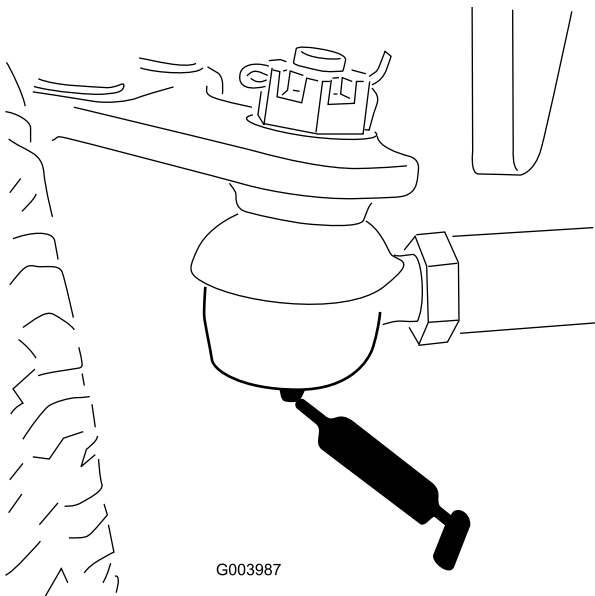

G003987

Figure 35

- Steering cylinder ball joints (2) and rear axle (1) (Figure 37)

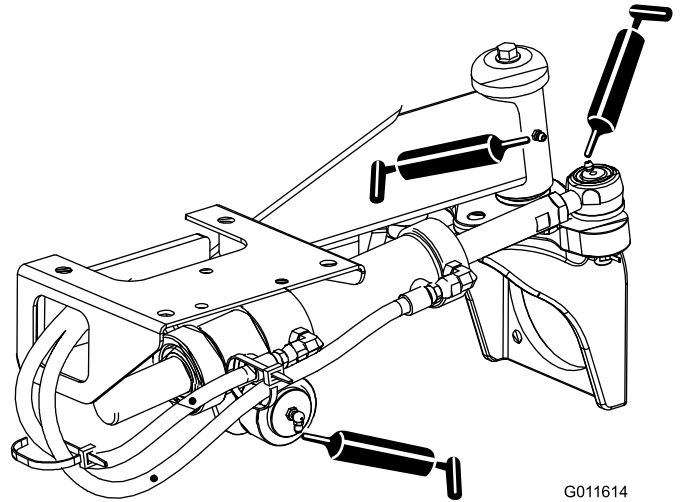

G011614

Figure 37

- Brake pedal (1) (Figure 38)

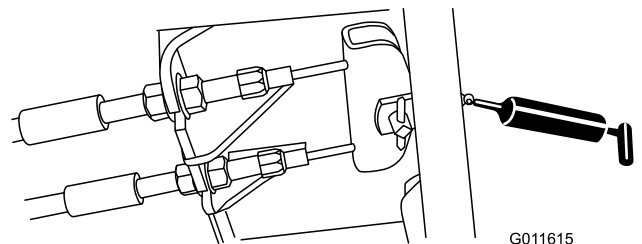

G011615

Figure 38

- Axle steering pivot (1) (Figure 36)

Engine Maintenance

Servicing the Air Cleaner

Check the air cleaner body for damage which could cause an air leak. Replace if damaged. Check the whole intake system for leaks, damage or loose hose clamps.

Service the air cleaner filter only when the service indicator (Figure 41) requires it. Changing the air filter before it is necessary only increases the chance of dirt entering the engine when the filter is removed.

Important: Be sure the cover is seated correctly and seals with the air cleaner body.

1. Release the latches securing the air cleaner cover to the air cleaner body (Figure 41).

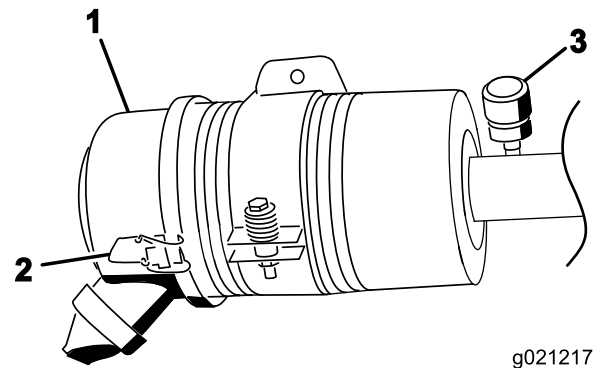

Figure 41

1. Air cleaner cover
2. Air cleaner cover latch
3. Air cleaner service indicator

2. Remove the cover from the air cleaner body. Before removing the filter, use low pressure air (40 psi, clean and dry) to help remove large accumulations of debris packed between outside of the filter and the canister. **Avoid using high pressure air which could force dirt through the filter into the intake tract.**

This cleaning process prevents debris from migrating into the intake when the filter is removed.

3. Remove and replace the filter (Figure 42).

Cleaning of the used element is not recommended due to the possibility of damage to the filter media. Inspect the new filter for shipping damage, checking the sealing end of the filter and the body. **Do not use a damaged element.** Insert the new filter by applying pressure to the outer rim of the element to seat it in the canister. **Do not apply pressure to the flexible center of the filter.**

- Cutting unit spindle shaft bearings (2 per cutting unit) (Figure 39)

Note: Either fitting can be used, whichever is more accessible. Pump grease into the fitting until a small amount appears at bottom of the spindle housing (under the deck).

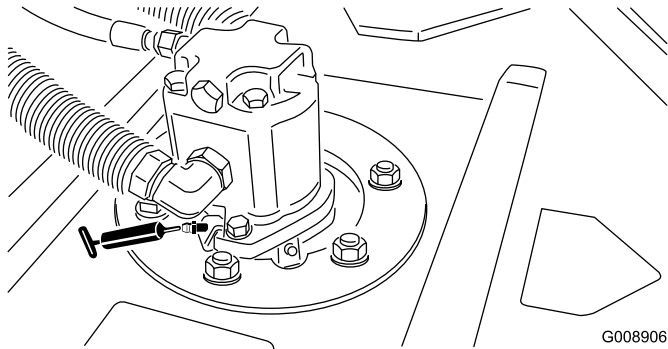

Figure 39

- Rear roller bearings (2 per cutting unit) (Figure 40)

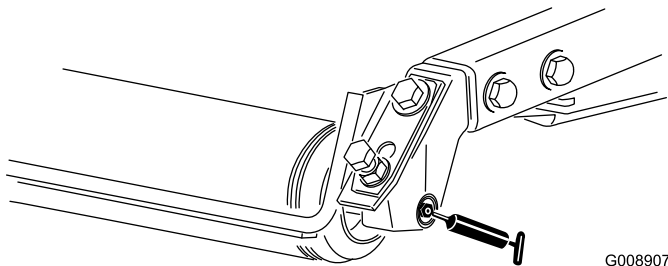

Figure 40

Note: Make sure the grease groove in each roller mount aligns with the grease hole in each end of the roller shaft. To help align the groove and hole, there is also an alignment mark on one end of the roller shaft.

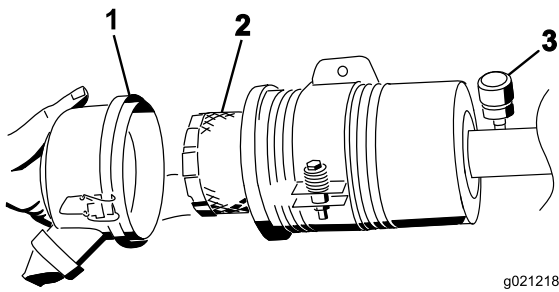

Figure 42

1. Air cleaner cover
2. Air cleaner filter
3. Air cleaner indicator

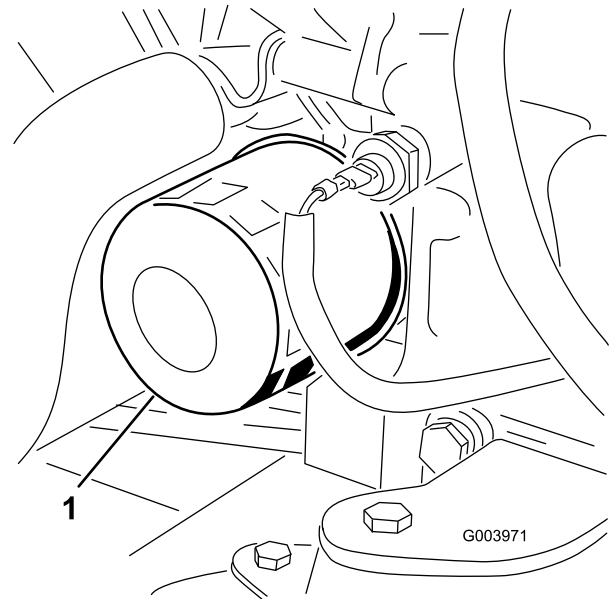

Figure 44

1. Oil filter

4. Apply a light coat of clean oil to the new filter seal.
5. Install the replacement oil filter to the filter adapter. Turn the oil filter clockwise until the rubber gasket contacts the filter adapter, then tighten the filter an additional 1/2 turn.

Important: Do not over-tighten the filter.

6. Add oil to the crankcase; refer to Checking the Engine Oil.

Servicing the Engine Oil and Filter

Change the engine oil and filter initially after the first 50 hours of operation and every 150 hours thereafter.

1. Remove the drain plug (Figure 43) and let the oil flow into a drain pan.

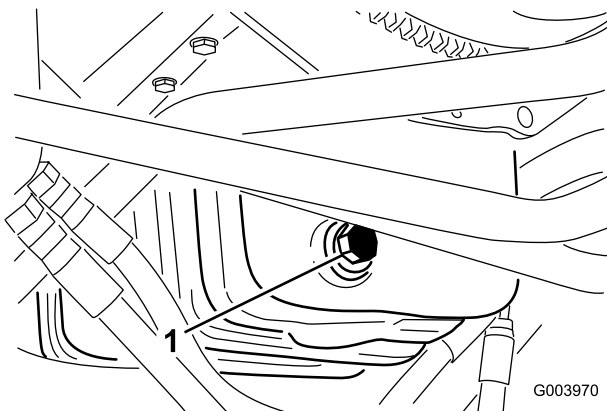

Figure 43

1. Oil drain plug

2. When the oil stops, install the drain plug.
3. Remove the oil filter (Figure 44).

Adjusting the Throttle

1. Position the throttle lever forward so it is approximately 3 mm (1/8 inch) from the front of the control arm slot.
2. Loosen the throttle cable connector, on the throttle cable, next to the injection pump lever (Figure 45).

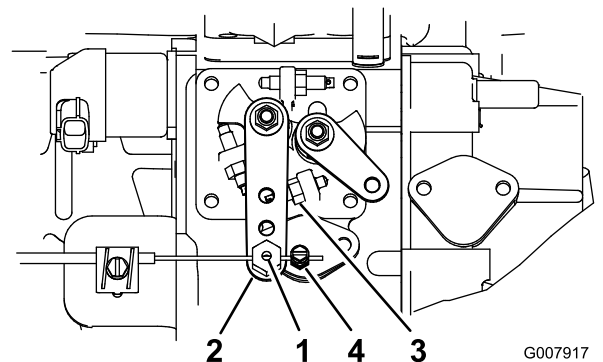

Figure 45

1. Throttle cable pivot
2. Injection pump lever arm
3. High idle stop
4. Throttle cable connector

3. Hold the injection pump lever arm against the high idle stop (Figure 45).

4. While pulling the throttle cable, to remove any slack, tighten the throttle cable connector.

Note: When tightened, the cable pivot must be free to swivel on the injection pump lever arm.

5. If the throttle does not stay in position during operation, increase the torque on the locknut, used to set the friction device on the throttle lever.

Fuel System Maintenance

⚠ DANGER

Under certain conditions, diesel fuel and fuel vapors are highly flammable and explosive. A fire or explosion from fuel can burn you and others and can cause property damage.

- Use a funnel and fill the fuel tank outdoors, in an open area, when the engine is off and is cold. Wipe up any fuel that spills.
- Do not fill the fuel tank completely full. Add fuel to the fuel tank until the level is 6 to 13 mm (1/4 to 1/2 inch) below the bottom of the filler neck. This empty space in the tank allows the fuel to expand.
- Never smoke when handling fuel, and stay away from an open flame or where fuel fumes may be ignited by a spark.
- Store fuel in a clean, safety-approved container and keep the cap in place.

Draining the Fuel Tank

Service Interval: Every 800 hours

Before storage

Drain and clean the fuel tank if the fuel system becomes contaminated or if the machine is to be stored for an extended period. Use clean fuel to flush out the tank.

Checking the Fuel Lines and Connections

Check the fuel lines and connections every 400 hours or yearly, whichever comes first. Inspect them for deterioration, damage, or loose connections.

Servicing the Water Separator

Service Interval: Every 400 hours

Drain water or other contaminants from water separator (Figure 46) daily. Replace filter canister after every 400 hours of operation.

1. Place a clean container under the fuel filter.
2. Loosen the drain plug on the bottom of the filter canister.

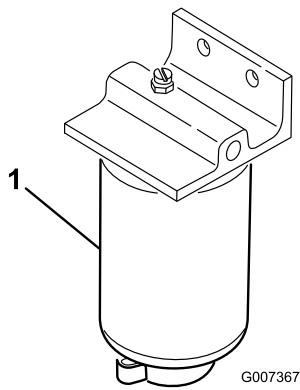

Figure 46

1. Water separator filter canister

-
3. Clean the area where the filter canister mounts.
 4. Remove the filter canister and clean the mounting surface.
 5. Lubricate the gasket on the filter canister with clean oil.
 6. Install the filter canister by hand until the gasket contacts mounting surface, then rotate it an additional 1/2 turn.
 7. Tighten the drain plug on the bottom of the filter canister.

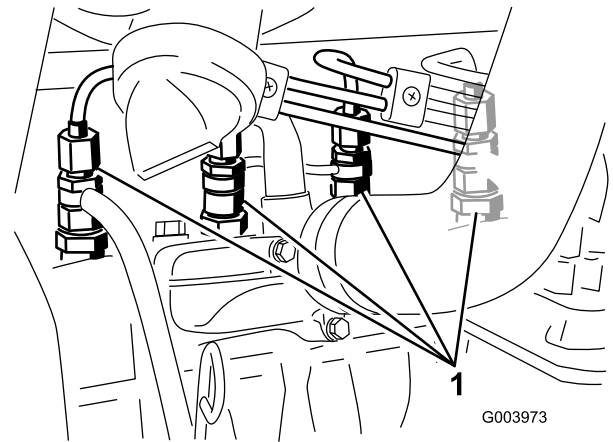

Figure 47

1. Fuel injectors

-
2. Turn the key in the key switch to the On position and watch the fuel flow around the connector. When you observe a solid flow of fuel, turn the key to the Off position.
 3. Tighten the pipe connector securely.
 4. Repeat steps 1 through 3 on the remaining nozzles.

Fuel Pick-up Tube Screen

The fuel pick-up tube, located inside the fuel tank, is equipped with a screen to help prevent debris from entering the fuel system. Remove the fuel pick-up tube and clean screen as required.

Bleeding Air from the Fuel Injectors

Note: This procedure should be used only if the fuel system has been purged of air through normal priming procedures and the engine will not start; refer to Bleeding the Fuel System.

1. Loosen the pipe connection to the No. 1 nozzle and holder assembly (Figure 47).

Electrical System Maintenance

Important: Before welding on the machine, disconnect both cables from the battery, both wire harness plugs from the electronic control module, and the terminal connector from the alternator to prevent damage to the electrical system.

Servicing the Battery

WARNING

CALIFORNIA Proposition 65 Warning

Battery posts, terminals, and related accessories contain lead and lead compounds, chemicals known to the State of California to cause cancer and reproductive harm.
Wash hands after handling.

⚠ DANGER

Battery electrolyte contains sulfuric acid which is a deadly poison and causes severe burns.

- Do not drink electrolyte and avoid contact with skin, eyes, or clothing. Wear safety glasses to shield your eyes and rubber gloves to protect your hands.
- Fill the battery where clean water is always available for flushing the skin.

⚠ WARNING

Charging the battery produces gasses that can explode.

Never smoke near the battery and keep sparks and flames away from it.

Check the battery condition weekly or after every 50 hours of operation. Keep the terminals and the entire battery case clean because a dirty battery will discharge slowly. To clean the battery, wash the entire case with a solution of baking soda and water. Rinse it with clear water.

Fuses

There are 8 fuses in the electrical system. The fuse block (Figure 48) is located behind the control arm access panel.

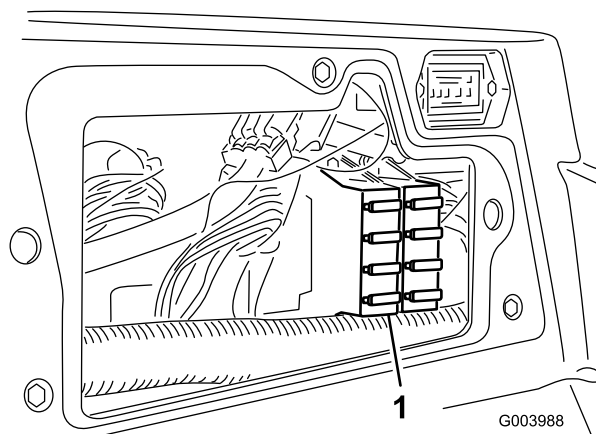

Figure 48

1. Fuse block

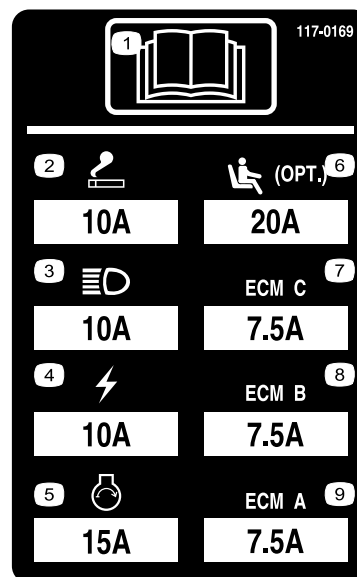

Figure 49

Drive System Maintenance

Adjusting the Traction Drive for Neutral

The machine must not creep when the traction pedal is released. If it does creep, adjust as follows:

1. Park the machine on a level surface, stop the engine, and lower the cutting decks to the floor.
2. Jack up the machine until all the tires are off the shop floor. Support the machine with jack stands to prevent it from falling accidentally.
3. On the right side of the hydrostat, loosen the locknut on the traction adjustment cam (Figure 50).

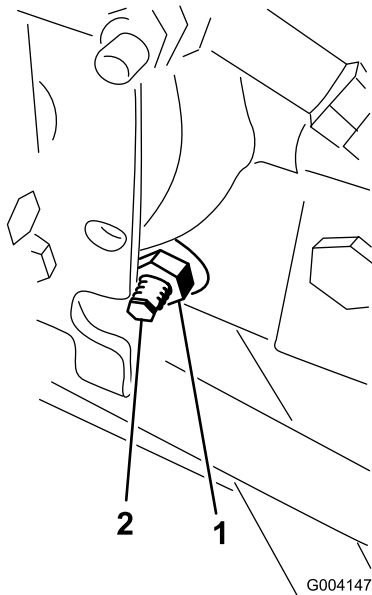

Figure 50

1. Locknut
2. Traction adjustment cam

⚠ WARNING

The engine must be running so the final adjustment of the traction adjustment cam can be performed. This could cause personal injury.

Keep hands, feet, face, and other body parts away from the muffler, other hot parts of the engine, and any rotating parts.

4. Start the engine and rotate the cam hex in either direction until the wheels cease rotation.
5. Tighten the locknut to secure the adjustment.
6. Stop the engine. Remove the jack stands and lower the machine to the shop floor.

7. Test drive the machine to make sure it does not creep.

Adjusting the Rear Wheel Toe-in

1. Rotate the steering wheel so that the rear wheels are straight ahead.
2. Loosen the jam nut on each end of the tie rod (Figure 51).

Note: The end of the tie rod with the external groove is a left hand thread.

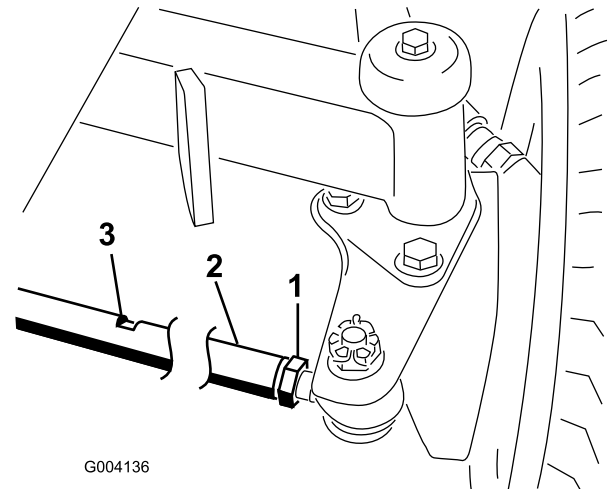

Figure 51

1. Jam nut
2. Tie rod
3. Wrench slot

3. Using the wrench slot, rotate the tie rod
4. Measure the distance at the front and rear of the rear wheels at axle height. The distance at the front of the rear wheels should be less than 6 mm (1/4 inch) of the distance measured at the rear of the wheels.
5. Repeat procedure as required.

Cooling System Maintenance

Removing Debris from the Cooling System

Remove debris from the screen, oil coolers, and radiator daily (clean more frequently in dirty conditions).

1. Turn the engine off and remove the key from the ignition switch.
2. Thoroughly clean all debris out of the engine area.
3. Unlatch the clamp and pivot open the rear screen (Figure 52).

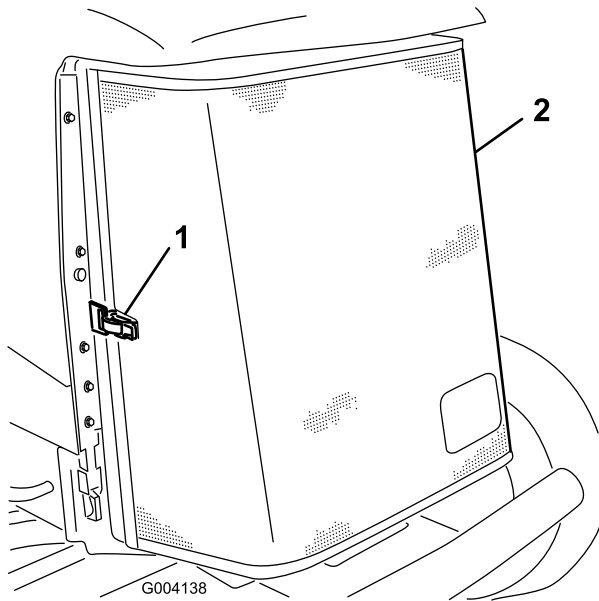

Figure 52

1. Rear screen latch
2. Rear screen

4. Clean the screen thoroughly with compressed air.
5. Pivot the latches inward to release the oil cooler (Figure 53).

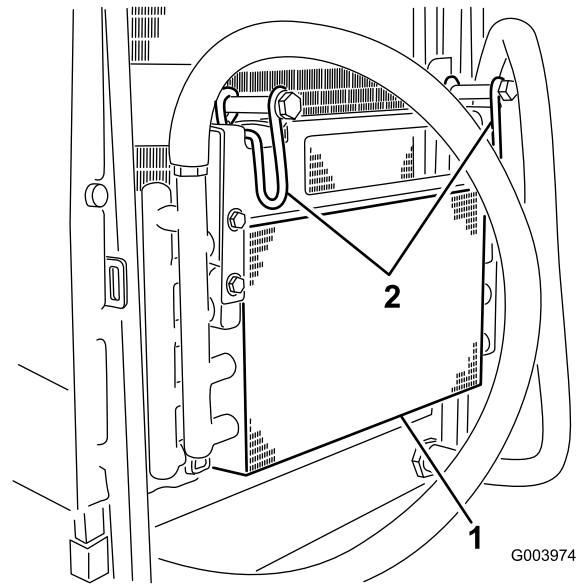

Figure 53

1. Oil cooler
2. Oil cooler latches

6. Thoroughly clean both sides of the oil cooler and the radiator (Figure 54) with compressed air.

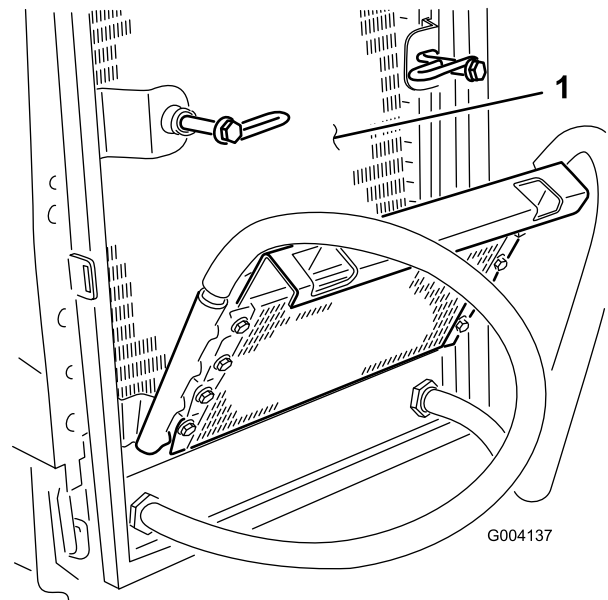

Figure 54

1. Radiator

7. Pivot the oil cooler back into position and secure the latches.
8. Close the screen and secure the latch.

Brake Maintenance

Adjusting the Parking Brakes

Adjust the brakes when there is more than 2.5 cm (1 inch) of free travel (Figure 55) of the brake pedal, or when more holding force is required. Free travel is the distance the brake pedal moves before you feel braking resistance.

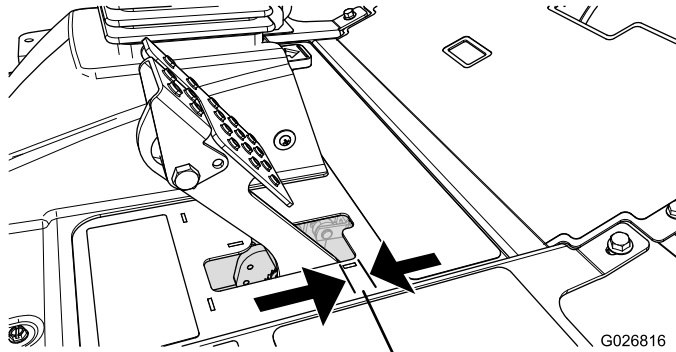

Figure 55

1. Free travel

Note: Use the wheel motor backlash to rock the drums back and forth to ensure that the drums are free prior to and after adjustment.

1. To reduce free travel of the brake pedals, tighten the brakes by loosening the front nut on the threaded end of the brake cable (Figure 56).

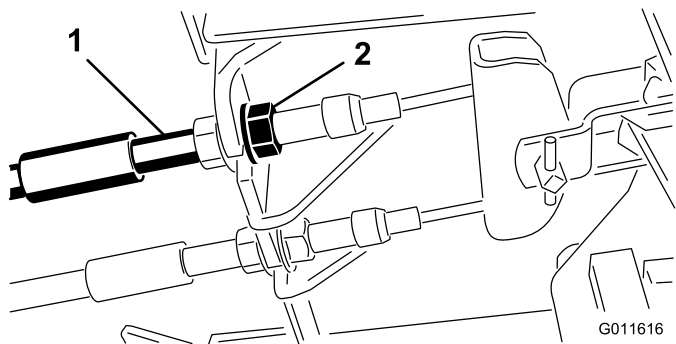

Figure 56

1. Brake cables
2. Front nuts

2. Tighten the rear nut to move the cable backward until brake pedals have .63 to 1.27 cm (1/4 to 1/2 inch) of free travel (Figure 55), before wheel lock up is achieved.
3. Tighten the front nuts, ensuring that both cables actuate the brakes simultaneously. Ensure that the cable conduit does not rotate during tightening procedure.

Adjusting the Parking Brake Latch

If the parking brake fails to engage and latch, an adjustment to the brake pawl is required.

1. Loosen the 2 screws securing the parking brake pawl to the frame (Figure 57).

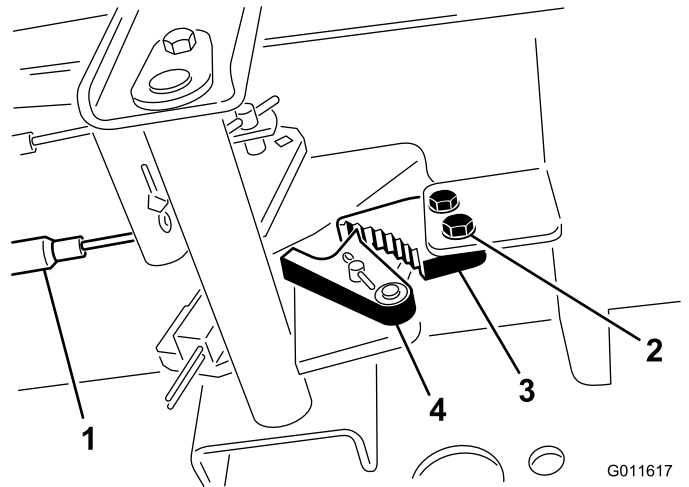

Figure 57

1. Brake cables
2. Screws (2)
3. Parking brake pawl
4. Brake detent

2. Press the parking brake pedal forward until the brake detent completely engages on the brake pawl (Figure 57).
3. Tighten the 2 screws locking the adjustment.
4. Press the brake pedal to release the parking brake.
5. Check the adjustment and readjust as required.

Belt Maintenance

Check the condition and tension of the alternator belt after the first day of operation and every 100 operating hours thereafter.

Tensioning the Alternator Belt

1. Open the hood.
2. Check the tension of the alternator belt by depressing it (Figure 58) midway between the alternator and the crankshaft pulleys with 10 kg (22 lb) of force.

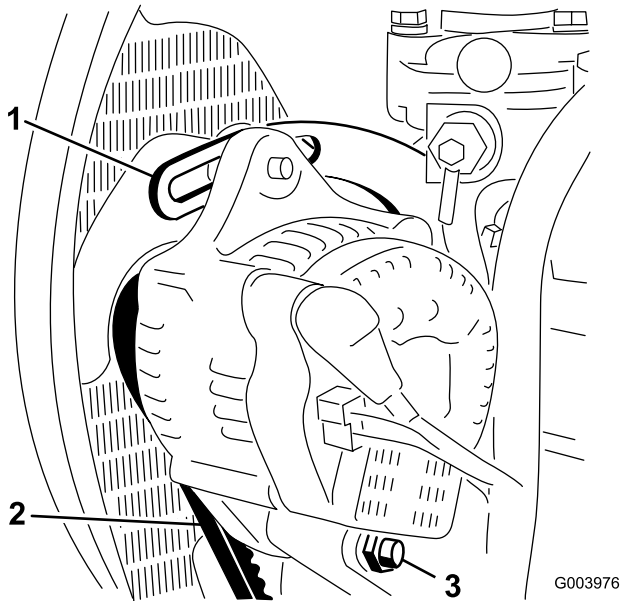

Figure 58

1. Brace
2. Alternator belt
3. Pivot bolt

The belt should deflect 11 mm (7/16 inch). If the deflection is incorrect, proceed to step 3. If correct, continue operation.

3. Loosen the bolt securing the brace to the engine (Figure 58), the bolt securing the alternator to the brace and the pivot bolt.
4. Insert a pry bar between the alternator and the engine and pry out on the alternator.
5. When you achieve the proper tension, tighten the alternator, brace and pivot bolts to secure the adjustment.

Hydraulic System Maintenance

Changing the Hydraulic Fluid

Change hydraulic fluid after every 800 operating hours, in normal conditions. If fluid becomes contaminated, contact your local Toro distributor because the system must be flushed. Contaminated fluid looks milky or black when compared to clean oil.

1. Stop the engine and raise the hood.
2. Place a large drain pan under the fitting secured to the bottom of the hydraulic fluid reservoir (Figure 59).

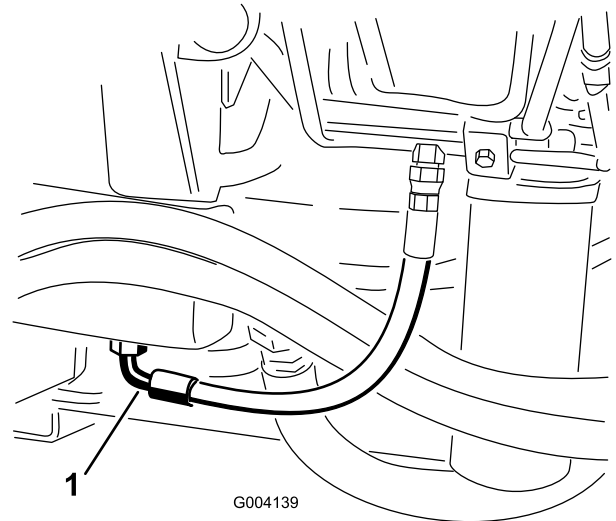

Figure 59

1. Hose

3. Disconnect the hose from the bottom of the fitting and let the hydraulic fluid flow into the drain pan.
4. Install the hose when hydraulic fluid stops draining.
5. Fill the reservoir with approximately 56.7 liters (15 U.S. gallons) of hydraulic fluid; refer to Checking the Hydraulic Fluid.

Important: Use only hydraulic fluids specified. Other fluids could cause system damage.

6. Install the reservoir cap.
7. Start the engine and use all of the hydraulic controls to distribute hydraulic fluid throughout the system. Also check for leaks.
8. Stop the engine.
9. Check the level of the hydraulic fluid and add enough to raise level to the Full mark on the dipstick.

Important: Do not over-fill.

Replacing the Hydraulic Filters

The hydraulic system is equipped with a service interval indicator (Figure 60). With the engine running, view the indicator, it should be in the Green zone. When the indicator is in the Red zone, change the hydraulic filters.

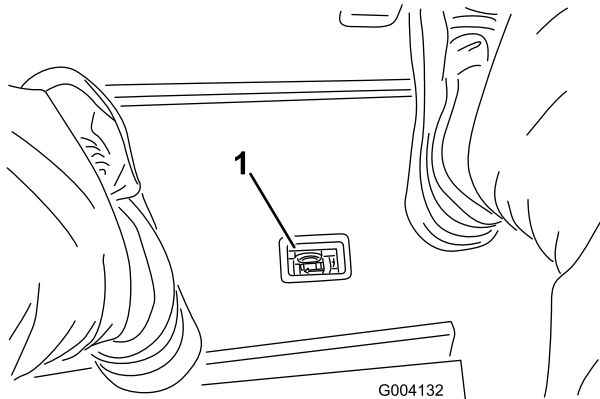

Figure 60

1. Hydraulic filter restriction indicator

Important: Use of any other filters may void the warranty on some components.

1. Position the machine on a level surface, lower the cutting decks, stop the engine, engage the parking brake, and remove the key from the ignition switch.
2. Clean the area around the filter mounting area and place a drain pan under filter (Figure 61) and (Figure 62).

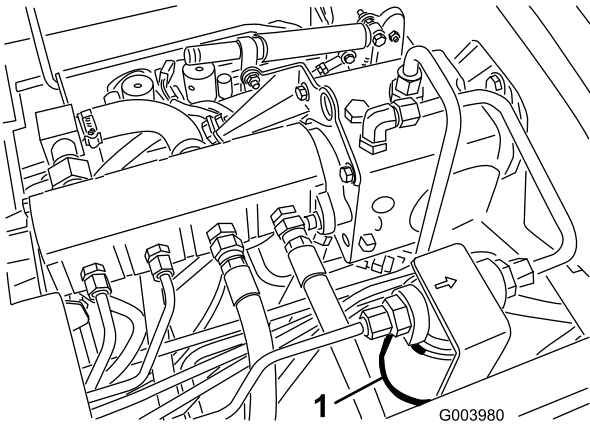

Figure 61

1. Hydraulic filter

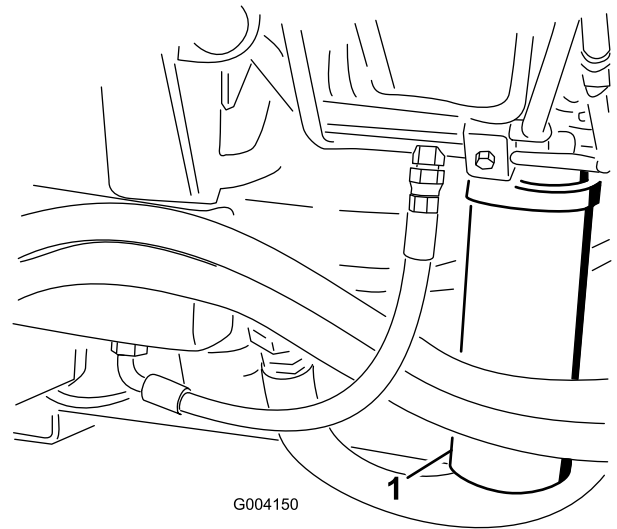

Figure 62

1. Hydraulic filter

3. Remove the filter.
4. Lubricate the gasket on the new filter with hydraulic oil.
5. Ensure that the filter mounting area is clean.
6. Install the filter by hand until the gasket contacts the mounting surface, then rotate it an additional 1/2 turn.
7. Repeat the procedure on the other filter.
8. Start the engine and let it run for about two minutes to purge air from the system.
9. Stop the engine and check for leaks.

Checking the Hydraulic Lines and Hoses

Daily, check hydraulic lines and hoses for leaks, kinked lines, loose mounting supports, wear, loose fittings, weather deterioration, and chemical deterioration. Make all necessary repairs before operating.

▲ WARNING

Hydraulic fluid escaping under pressure can penetrate skin and cause injury.

- Make sure all hydraulic fluid hoses and lines are in good condition and all hydraulic connections and fittings are tight before applying pressure to the hydraulic system.
- Keep your body and hands away from pin hole leaks or nozzles that eject high pressure hydraulic fluid.
- Use cardboard or paper to find hydraulic leaks.
- Safely relieve all pressure in the hydraulic system before performing any work on the hydraulic system.
- Get immediate medical help if fluid is injected into skin.

Hydraulic System Test Ports

Use the hydraulic system test ports to test the pressure in the hydraulic circuits. Contact your local Toro distributor for assistance.

Cutting Deck Maintenance

Separating the Cutting Decks from the Traction Unit

1. Position the machine on a level surface, lower the cutting decks to the floor, shut the engine off, and engage the parking brake.
2. Disconnect and remove the hydraulic motor from the deck (Figure 63). Cover the top of the spindle to prevent contamination.

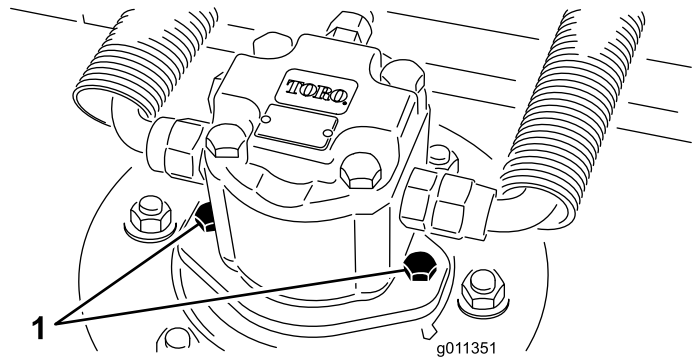

Figure 63

1. Motor mounting screws

3. Remove the lynch pin securing the deck carrier frame to the lift arm pivot pin (Figure 64).

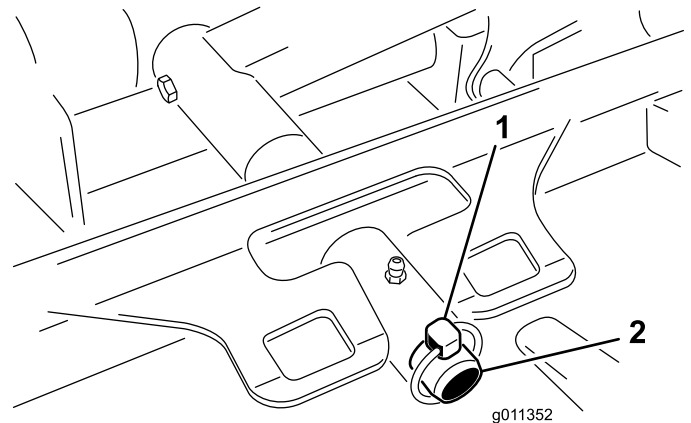

Figure 64

1. Lynch pin
2. Lift arm pivot pin

4. Roll the cutting deck away from the traction unit.

Mounting the Cutting Decks to the Traction Unit

1. Position machine on a level surface and shut engine off.
2. Move cutting deck into position in front of traction unit.

- Slide deck carrier frame onto lift arm pivot pin. Secure with lynch pin (Figure 64).
- Install the hydraulic motor to the deck (Figure 63). Make sure that the O-ring is in position and not damaged.
- Grease the spindle.

Servicing the Blade Plane

The rotary deck comes from the factory preset at 5 cm (2.00 inch) height-of-cut and blade rake of 7.9 mm (0.310 inch). The left-hand and right-hand heights are also preset to within ± 0.7 mm (0.030 inch) of the other.

The cutting deck is designed to withstand blade impacts without deformation of the chamber. If a solid object is struck, inspect the blade for damage and the blade plane for accuracy.

Inspecting the Blade Plane

- Remove the hydraulic motor from the cutting deck and remove the cutting deck from the tractor.
- Use a hoist (or minimum of two people) and place the cutting deck on a flat table.
- Mark one end of the blade with a paint pen or marker. Use this end of the blade to check all heights.
- Position the cutting edge of the marked end of the blade at 12 o'clock (straight ahead in the direction of mowing) (Figure 65) and measure height from table to cutting edge of blade.

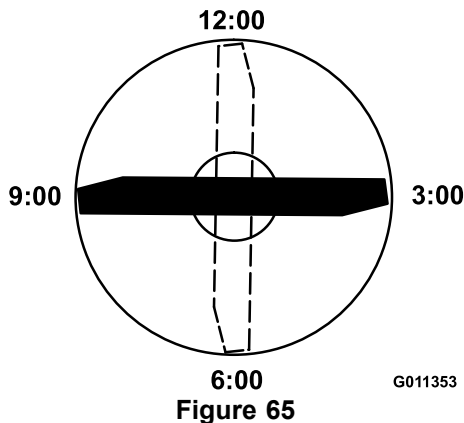

- Rotate the marked end of the blade to the 3 and 9 o'clock positions (Figure 65) and measure the heights.
- Compare the 12 o'clock measured height to the height-of-cut setting. It should be within 0.7 mm (0.030 inch). The 3 and 9 o'clock heights should be 3.8 ± 2.2 mm (0.150 ± 0.090 inch) higher than the 12 o'clock setting and within 2.2 mm (0.090 inch) of each other.

If any of these measurements are not within specification, proceed to Adjusting the Blade Plane.

Adjusting the Blade Plane

Start with the front adjustment (change one bracket at a time).

- Remove the height-of-cut bracket, (front, left, or right) from the deck frame (Figure 66).
- Adjust 1.5 mm (0.060 inch) shims and/or 0.7 mm (0.030 inch) shim between the deck frame and bracket to achieve the desired height setting (Figure 66).

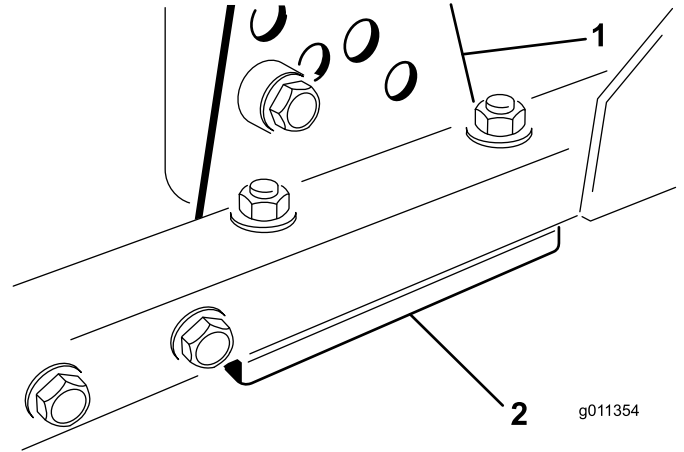

Figure 66

- Height of cut bracket
- Shims

- Install the height-of-cut bracket to the deck frame with the remaining shims assembled below the height-of-cut bracket.
- Secure the socket head bolt/spacer and flange nut.

Note: Socket head bolt/spacer are held together with Loctite to prevent the spacer from falling inside the deck frame.
- Verify the 12 o'clock height and adjust if needed.
- Determine if only one or both (right-hand and left-hand) height-of-cut brackets need to be adjusted. If the 3 or 9 o'clock side is 3.8 ± 2.2 mm (0.150 ± 0.090 inch) higher than the new front height then no adjustment is needed for that side. Adjust the other side to within ± 2.2 mm (0.090 inch) of the correct side.
- Adjust the right and/or left height-of-cut brackets by repeating steps 1 through 3.
- Secure the carriage bolts and flange nuts.
- Again, verify the 12, 3, and 9 o'clock heights.

Servicing the Cutter Blade

Removing the Cutter Blade

The blade must be replaced if a solid object is hit, the blade is out of balance, or if the blade is bent. Always use genuine Toro replacement blades to be sure of safety and optimum

performance. Never use replacement blades made by other manufacturers because they could be dangerous.

1. Raise the cutting deck to the highest position, shut the engine off, and engage the parking brake. Block the cutting deck to prevent it from falling accidentally.
2. Grasp the end of the blade using a rag or thickly padded glove. Remove the blade bolt, anti-scalp cup, and blade from the spindle shaft (Figure 67).

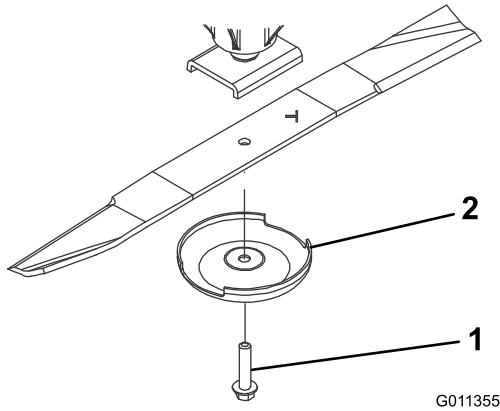

Figure 67

1. Blade bolt
2. Anti-scalp cup

3. Install the blade, sail facing toward the cutting deck, with the anti-scalp cup and blade bolt (Figure 67). Tighten blade bolt to 115–149 N-m (85–110 ft-lb).

⚠ DANGER

A worn or damaged blade can break, and a piece of the blade could be thrown into the operator's or bystander's area, resulting in serious personal injury or death

- Inspect the blade periodically for wear or damage.
- Never weld a broken or cracked blade.
- Always replace a worn or damaged blade.

Inspecting and Sharpening the Blade

1. Raise the cutting deck to the highest position, shut the engine off, and engage the parking brake. Block the cutting deck to prevent it from falling accidentally.
2. Examine the cutting ends of the blade carefully, especially where the flat and curved parts of the blade meet (Figure 68). Since sand and abrasive material can wear away the metal that connects the flat and curved parts of the blade, check the blade before using the machine. If wear is noticed (Figure 68), replace the blade; refer to Removing the Cutter Blade.

⚠ DANGER

If the blade is allowed to wear, a slot will form between the sail and flat part of the blade (Figure 68). Eventually a piece of the blade may break off and be thrown from under the housing, possibly resulting in serious injury to yourself or bystanders.

- Inspect the blade periodically for wear or damage.
- Always replace a worn or damaged blade.

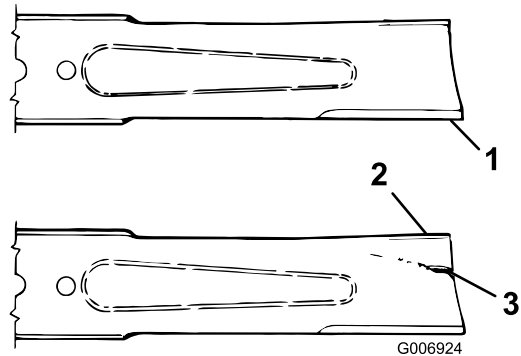

Figure 68

1. Cutting edge
2. Sail
3. Wear/slot/crack

3. Inspect the cutting edges of all blades. Sharpen the cutting edges if they are dull or nicked. Sharpen only the top of the cutting edge and maintain the original cutting angle to make sure of sharpness (Figure 69). The blade will remain balanced if the same amount of metal is removed from both cutting edges.

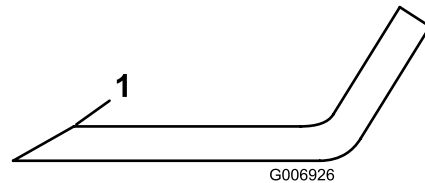

Figure 69

1. Sharpen at this angle only

4. To check the blade for being straight and parallel, lay the blade on a level surface and check its ends. The ends of the blade must be slightly lower than the center, and the cutting edge must be lower than the heel of the blade. This blade will produce good quality of cut and require minimal power from the engine. By contrast a blade that is higher at the ends than the center, or if cutting edge is higher than the heel, the blade is bent or warped and must be replaced.

5. Install the blade, sail facing toward cutting deck, with the anti-scalp cup and blade bolt. Tighten the blade bolt to 115–149 N-m (85–110 ft-lb).

Checking the Blade Stopping Time

Service Interval: Before each use or daily

The blades of the cutting deck should come to a complete stop in approximately 5 seconds after you shut down the cutting deck engagement switch.

Note: Make sure the decks are lowered onto a clean section of turf or hard surface to avoid thrown dust and debris.

To verify this stopping time, have a second person stand back from the deck at least 6 m (20 feet) and watch the blades on one of the cutting decks. Have the operator shut the cutting decks down and record the time it takes for the blades to come to a complete stop. If this time is greater than 7 seconds, the braking valve needs adjustment. Call your Toro Distributor for assistance in making this adjustment.

Servicing the Front Roller

Inspect the front roller for wear, excess wobble, or binding. Service or replace the roller or components if any of these conditions exist.

Disassembling the Front Roller

1. Remove the roller mounting bolt (Figure 70).
2. Insert a punch through the end of the roller housing and drive the opposite bearing out by alternating taps to the opposite side of inner bearing race. There should be a 1.5 mm (0.060 inch) lip of inner race exposed.

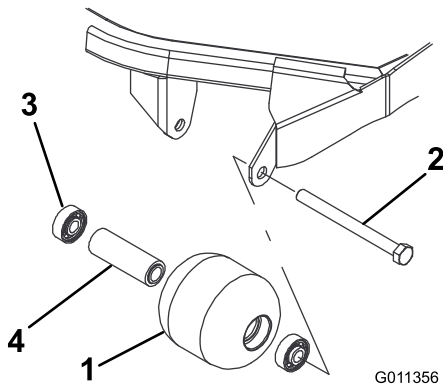

Figure 70

- | | |
|------------------|-------------------|
| 1. Front roller | 3. Bearing |
| 2. Mounting bolt | 4. Bearing spacer |

3. Push the second bearing out in press.
4. Inspect the roller housing, bearings, and bearing spacer for damage (Figure 70). Replace damaged components and assemble.

Assembling the Front Roller

1. Press the first bearing into the roller housing (Figure 70). Press on the outer race only or equally on the inner and outer race.

2. Insert the spacer (Figure 70).
3. Press the second bearing into the roller housing (Figure 70) pressing equally on the inner and outer race until the inner race comes in contact with the spacer.
4. Install the roller assembly into the deck frame.

Important: Securing the roller assembly with a gap larger than 1.5 mm (0.060 inch) creates a side load on the bearing and can lead to premature bearing failure

5. Verify that there is no more than a 1.5 mm (0.060 inch) gap between roller assembly and the roller mount brackets of the deck frame. If there is a gap over 1.5 mm (0.060 inch), install enough 5/8 inch diameter washers to take up the slop.
6. Secure the mounting bolt to 108 N-m (80 ft-lb).

Storage

Preparing the Traction Unit

1. Thoroughly clean the traction unit, cutting decks, and engine.
2. Check the tire pressure. Inflate all traction unit tires to 83 to 103 kPa (12 to 15 psi).
3. Check all fasteners for looseness and tighten them as necessary.
4. Grease all grease fittings and pivot points. Wipe up any excess lubricant.
5. Lightly sand and use touch-up paint on painted areas that are scratched, chipped, or rusted. Repair any dents in the metal body.
6. Service the battery and cables as follows:
 - A. Remove the battery terminals from the battery posts.
 - B. Clean the battery, terminals, and posts with a wire brush and baking soda solution.
 - C. Coat the cable terminals and battery posts with Grafo 112X skin-over grease (Toro Part No. 505-47) or petroleum jelly to prevent corrosion.
 - D. Slowly recharge the battery every 60 days for 24 hours to prevent lead sulfation of the battery.

Preparing the Engine

1. Drain the engine oil from the oil pan and replace the drain plug.
2. Remove and discard the oil filter. Install a new oil filter.
3. Refill the oil pan with designated quantity of motor oil.
4. Start the engine and run it at idle speed for approximately two minutes.
5. Stop the engine.
6. Thoroughly drain all fuel from the fuel tank, lines, and the fuel filter/water separator assembly.
7. Flush the fuel tank with fresh, clean diesel fuel.
8. Secure all fuel system fittings.
9. Thoroughly clean and service the air cleaner assembly.
10. Seal the air cleaner inlet and the exhaust outlet with weatherproof tape.
11. Check the antifreeze protection and add as needed for expected minimum temperature in your area.

Cutting Deck

If the cutting deck is separated from the traction unit for any length of time, install a spindle plug in the top of the spindle to protect the spindle from dust and water.

Notes:

Notes:



The Toro Total Coverage Guarantee

A Limited Warranty

Conditions and Products Covered

The Toro Company and its affiliate, Toro Warranty Company, pursuant to an agreement between them, jointly warrant your Toro Commercial product ("Product") to be free from defects in materials or workmanship for two years or 1500 operational hours*, whichever occurs first. This warranty is applicable to all products with the exception of Aerators (refer to separate warranty statements for these products). Where a warrantable condition exists, we will repair the Product at no cost to you including diagnostics, labor, parts, and transportation. This warranty begins on the date the Product is delivered to the original retail purchaser.

* Product equipped with an hour meter.

Instructions for Obtaining Warranty Service

You are responsible for notifying the Commercial Products Distributor or Authorized Commercial Products Dealer from whom you purchased the Product as soon as you believe a warrantable condition exists. If you need help locating a Commercial Products Distributor or Authorized Dealer, or if you have questions regarding your warranty rights or responsibilities, you may contact us at:

Toro Commercial Products Service Department
Toro Warranty Company
8111 Lyndale Avenue South
Bloomington, MN 55420-1196
952-888-8801 or 800-952-2740
E-mail: commercial.warranty@toro.com

Owner Responsibilities

As the Product owner, you are responsible for required maintenance and adjustments stated in your *Operator's Manual*. Failure to perform required maintenance and adjustments can be grounds for disallowing a warranty claim.

Items and Conditions Not Covered

Not all product failures or malfunctions that occur during the warranty period are defects in materials or workmanship. This warranty does not cover the following:

- Product failures which result from the use of non-Toro replacement parts, or from installation and use of add-on, or modified non-Toro branded accessories and products. A separate warranty may be provided by the manufacturer of these items.
- Product failures which result from failure to perform recommended maintenance and/or adjustments. Failure to properly maintain your Toro product per the Recommended Maintenance listed in the *Operator's Manual* can result in claims for warranty being denied.
- Product failures which result from operating the Product in an abusive, negligent, or reckless manner.
- Parts subject to consumption through use unless found to be defective. Examples of parts which are consumed, or used up, during normal Product operation include, but are not limited to, brake pads and linings, clutch linings, blades, reels, rollers and bearings (sealed or greasable), bed knives, spark plugs, castor wheels and bearings, tires, filters, belts, and certain sprayer components such as diaphragms, nozzles, and check valves, etc.
- Failures caused by outside influence. Conditions considered to be outside influence include, but are not limited to, weather, storage practices, contamination, use of unapproved fuels, coolants, lubricants, additives, fertilizers, water, or chemicals, etc.
- Failure or performance issues due to the use of fuels (e.g. gasoline, diesel, or biodiesel) that do not conform to their respective industry standards.

Countries Other than the United States or Canada

Customers who have purchased Toro products exported from the United States or Canada should contact their Toro Distributor (Dealer) to obtain guarantee policies for your country, province, or state. If for any reason you are dissatisfied with your Distributor's service or have difficulty obtaining guarantee information, contact the Toro importer.

- Normal noise, vibration, wear and tear, and deterioration.
- Normal "wear and tear" includes, but is not limited to, damage to seats due to wear or abrasion, worn painted surfaces, scratched decals or windows, etc.

Parts

Parts scheduled for replacement as required maintenance are warranted for the period of time up to the scheduled replacement time for that part. Parts replaced under this warranty are covered for the duration of the original product warranty and become the property of Toro. Toro will make the final decision whether to repair any existing part or assembly or replace it. Toro may use remanufactured parts for warranty repairs.

Deep Cycle and Lithium-Ion Battery Warranty:

Deep cycle and Lithium-Ion batteries have a specified total number of kilowatt-hours they can deliver during their lifetime. Operating, recharging, and maintenance techniques can extend or reduce total battery life. As the batteries in this product are consumed, the amount of useful work between charging intervals will slowly decrease until the battery is completely worn out. Replacement of worn out batteries, due to normal consumption, is the responsibility of the product owner. Battery replacement may be required during the normal product warranty period at owner's expense. Note: (Lithium-Ion battery only): A Lithium-Ion battery has a part only prorated warranty beginning year 3 through year 5 based on the time in service and kilowatt hours used. Refer to the *Operator's Manual* for additional information.

Maintenance is at Owner's Expense

Engine tune-up, lubrication, cleaning and polishing, replacement of filters, coolant, and completing recommended maintenance are some of the normal services Toro products require that are at the owner's expense.

General Conditions

Repair by an Authorized Toro Distributor or Dealer is your sole remedy under this warranty.

Neither The Toro Company nor Toro Warranty Company is liable for indirect, incidental or consequential damages in connection with the use of the Toro Products covered by this warranty, including any cost or expense of providing substitute equipment or service during reasonable periods of malfunction or non-use pending completion of repairs under this warranty. Except for the Emissions warranty referenced below, if applicable, there is no other express warranty. All implied warranties of merchantability and fitness for use are limited to the duration of this express warranty.

Some states do not allow exclusions of incidental or consequential damages, or limitations on how long an implied warranty lasts, so the above exclusions and limitations may not apply to you. This warranty gives you specific legal rights, and you may also have other rights which vary from state to state.

Note regarding engine warranty:

The Emissions Control System on your Product may be covered by a separate warranty meeting requirements established by the U.S. Environmental Protection Agency (EPA) and/or the California Air Resources Board (CARB). The hour limitations set forth above do not apply to the Emissions Control System Warranty. Refer to the Engine Emission Control Warranty Statement supplied with your product or contained in the engine manufacturer's documentation for details