



Count on it.

Parts Catalog

**TimeCutter® SS 4260 Riding
Mower**

Model No. 74636—Serial No. 314000001 and Up



Ordering Replacement Parts

To order replacement parts, please supply the part number, the quantity, and the description of each part desired.

Understanding Reference Numbers

Each identified part in an illustration has a reference number. The reference number for a part also appears in the parts list, along with other information about the part.

This catalog uses two special reference number formats, one to indicate parts in a service assembly and another to indicate the quantity of a given part in an illustration.

Service Assembly Reference Numbers

Parts in service assemblies have reference numbers in the form a:b. The a represents the reference number of the entire service assembly and the b represents a sequential number unique to each part within the service assembly.

For example, a wheel assembly might be identified by reference number 6, the tire by 6:1, the valve by 6:2, and the wheel by 6:3. When you order the assembly identified by reference number 6, you receive all parts identified by reference numbers 6:1, 6:2, and 6:3. However, you may also order any part individually. Reference numbers of this type appear in illustration and in parts lists.

Reference Numbers Indicating Quantity

In an illustration, if a reference number indicates more than one part, the reference number has the form nX y. The n represents the quantity of the part, the X is the multiplication symbol, and the y represents the reference number.

For example, in an illustration, the reference number 2X 37 means that two of the parts identified by reference number 37 are indicated.

List of Abbreviations

AR: as required	HLH: hex lag head	PTO: power-take-off
ASM: assembly	HOC: height-of-cut	RH: right hand
BBC: blade brake control	HSBH: hex socket button head	ROPS: roll-over protection system
BHTF: button head thread forming	HSFH: hex socket flat head	RRB: rear roller brush
CARR: carriage	HSH: hex socket head	SFH: slotted fillister head
CCW: counter clockwise	HWH: hex washer head	SHH: slotted hex head
CW: clockwise	HWHTF: hex washer head thread forming	SHWH: slotted hex washer head
DEG: degrees	HYD: hydraulic	SPH: slotted pan head
DPA: Dual Point Adjustment	LH: left hand	SQH: square head
ECM: electronic control module	LP: Liquefied Petroleum Gas	SRH: slotted round head
EXT: external	LPG: Liquefied Petroleum Gas	STD: standard
FH: flat head	NI: nylon insert	TAP: self tapping
GA: gauge	NPTF: national pipe thread fine	TTH: torx truss head
HD: heavy-duty	PFH: phillips flat head	
HF: hex flange	PPH: phillips pan head	
HH: hex head	PPHTF: phillips pan head thread forming	
HHF: hex head flange	PRH: phillips round head	
HHFTF: hex head flange thread forming	PTH: phillips truss head	
HJ: hex jam		

Contents

Frame, Front Axle and Caster Wheel Assembly	4
Caster Wheel Assembly No. 130-0736.....	6
Motion Control Assembly	8
Belt and Idler Assembly.....	10
Hydro Transaxle Drive and Rear Wheel Assembly	12
Right Hand Hydro Transaxle Assembly No. 119-3331	14
Left Hand Hydro Transaxle Assembly No. 119-3330	16
Clutch Assembly.....	18
Engine and Muffler Assembly.....	20
Body Styling and Fuel Pod Assembly	22
Fuel Delivery Assembly.....	24
Battery and Electrical Assembly.....	26
Fuel Delivery Assembly.....	28
Seat Assembly	30
Deck Lift Assembly.....	32
42 Inch Deck Assembly.....	34
42 Inch Deck Assembly No. 119-8840	36
42 Inch Deck, Belt and Blade Assembly	38
Attachments and Accessories	40

Frame, Front Axle and Caster Wheel Assembly

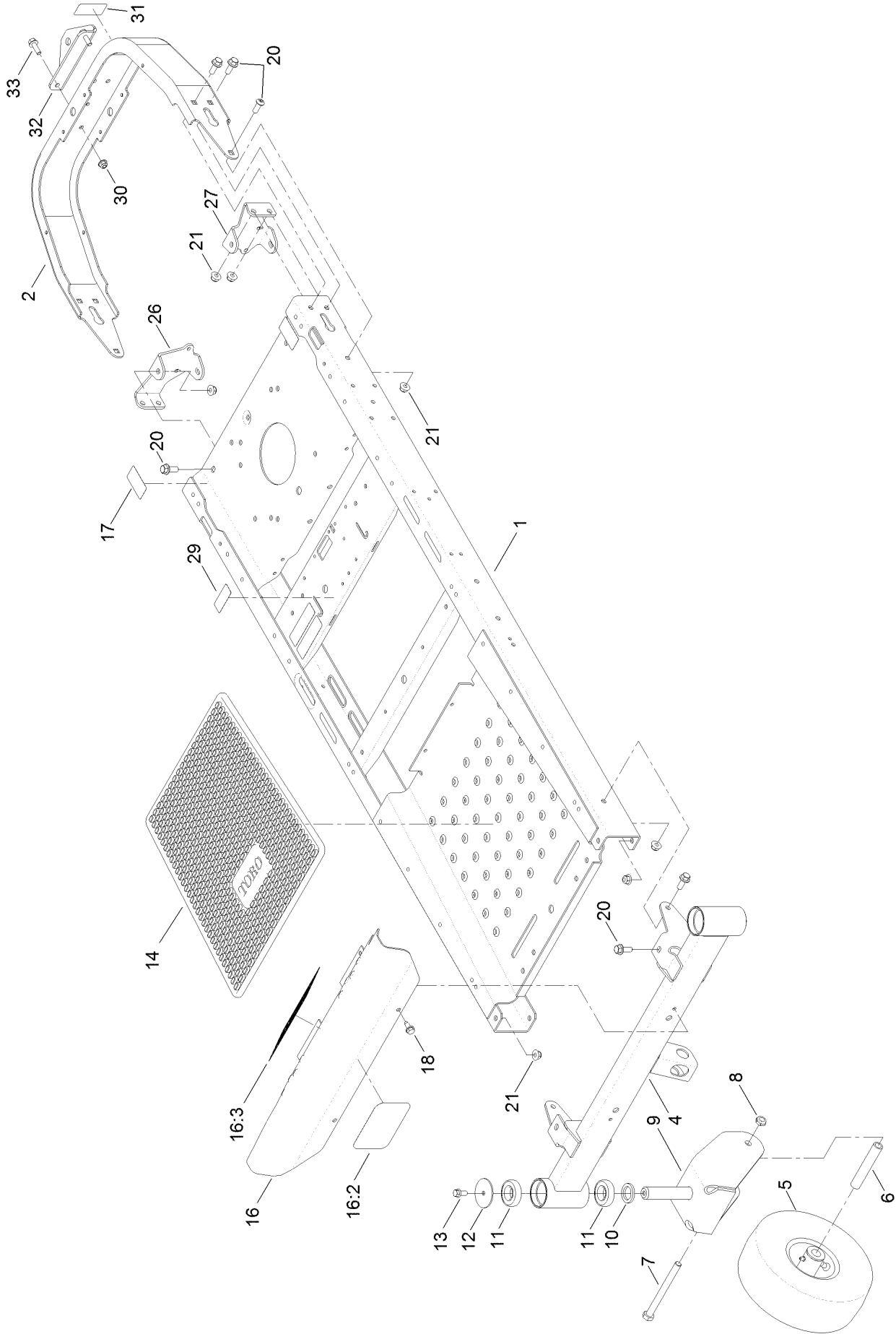

Frame, Front Axle and Caster Wheel Assembly (continued)

<i>Ref.</i>	<i>Part Number</i>	<i>Qty.</i>	<i>Description</i>	<i>Ref.</i>	<i>Part Number</i>	<i>Qty.</i>	<i>Description</i>
1	121-2970-01	1	Frame	16:2	105-8278	1	Decal
2	110-1920-01	1	Bumper-Rear	16:3	120-2239	1	Decal-Danger
4	120-5516-01	1	Axle-Front	17	121-2989	2	Decal-Bypass
5	130-0736	2	Caster Wheel ASM	18	32144-70	2	Screw-HWHTF
6	104-3667	2	Spanner-Wheel	20	3234-42	14	Screw-HHF
7	325-22	2	Screw-HH	21	104-8301	14	Nut-Flange, NI
8	3296-45	2	Nut-Lock, NI	26	121-0737-01	1	Mount-Hydro, Rear (RH)
9	120-2266-01	2	Fork-Caster	27	121-0738-01	1	Mount-Hydro, Rear (LH)
10	117-7394	2	Washer-Thrust	29	121-5684	1	Decal-Location, Service Dealer
11	109-3678	4	Bearing-Ball	30	104-8300	2	Nut-Flange, NI
12	119-8915	2	Washer	31	109-7076	1	Decal
13	3234-47	2	Screw-HHF	32	117-1232-03	1	Bracket-Hitch
14	120-5455	1	Mat-Floor	33	3234-29	2	Screw-HHF
16	125-0072	1	Footrest ASM				

Caster Wheel Assembly No. 130-0736

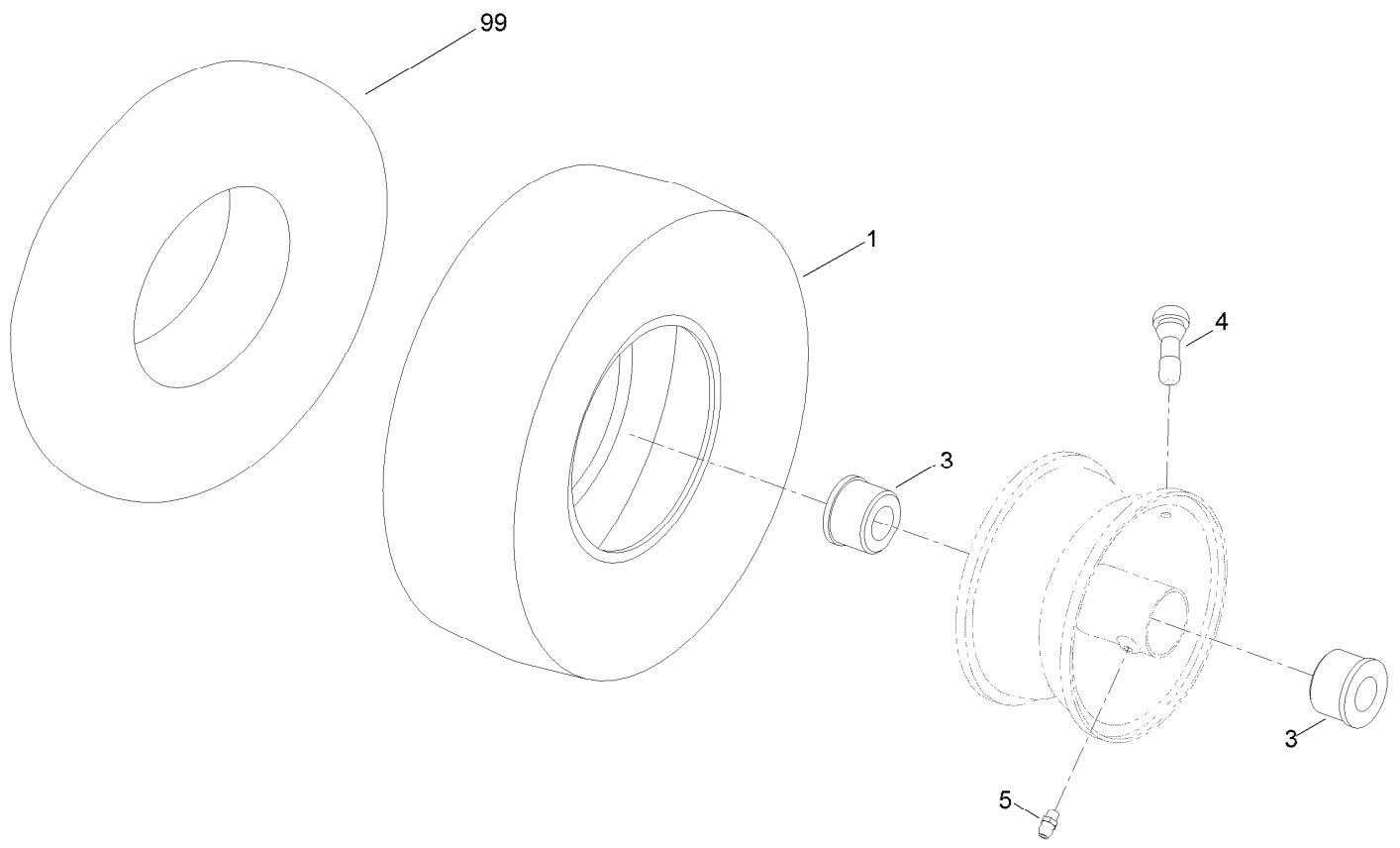

Caster Wheel Assembly No. 130-0736 (continued)

<i>Ref.</i>	<i>Part Number</i>	<i>Qty.</i>	<i>Description</i>	<i>Ref.</i>	<i>Part Number</i>	<i>Qty.</i>	<i>Description</i>
1	130-0735	1	Tire	5	302-5	1	Fitting-Grease
3	114-1640	2	Bushing-Flange	99	105-0844	1	Tube-Inner
4	232-27	1	Stem-Valve				

Motion Control Assembly

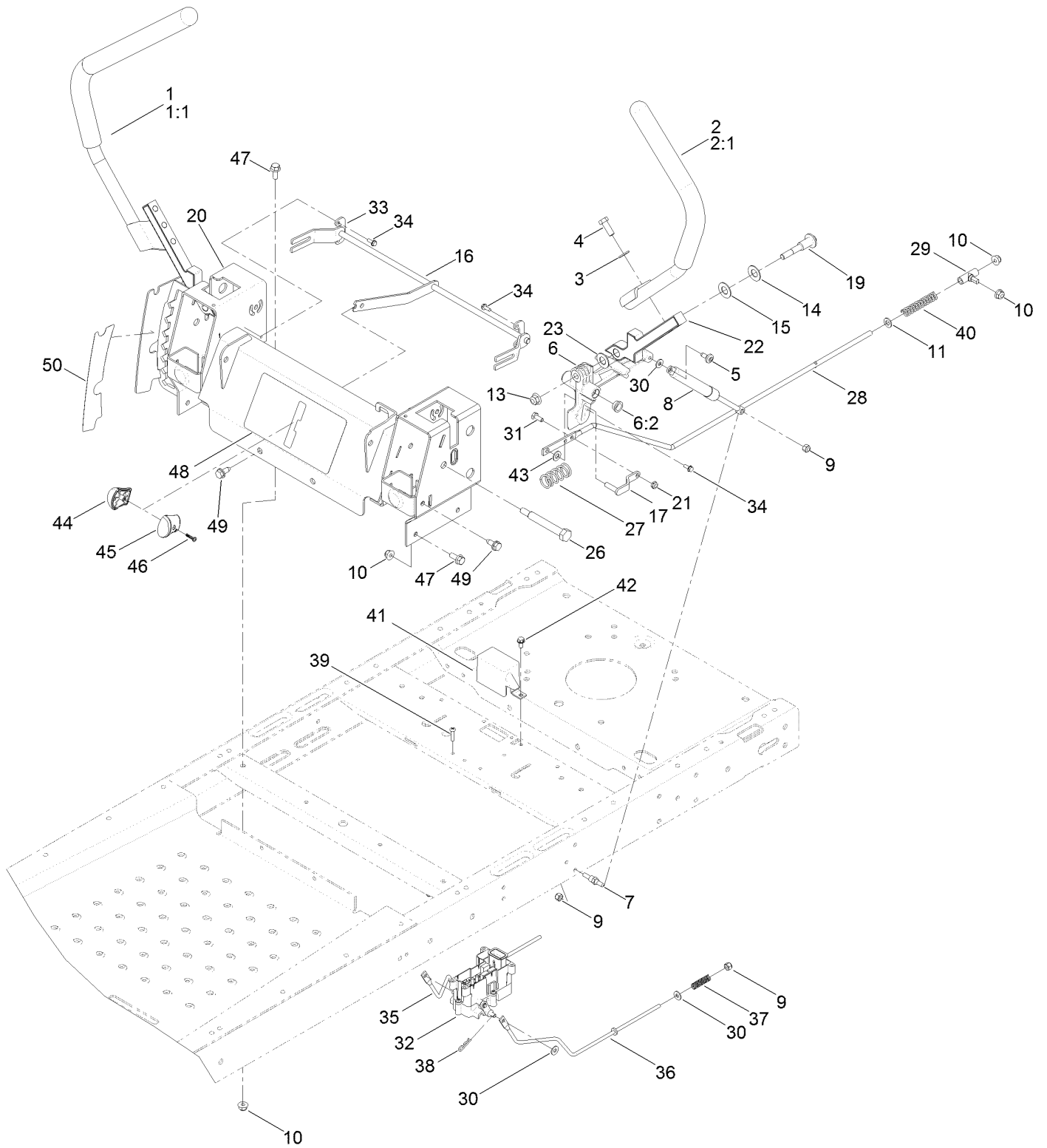

Motion Control Assembly (continued)

<i>Ref.</i>	<i>Part Number</i>	<i>Qty.</i>	<i>Description</i>	<i>Ref.</i>	<i>Part Number</i>	<i>Qty.</i>	<i>Description</i>
1	121-0731	1	Handle-Control, RH	27	119-8876	2	Spring-Return
1:1	121-0726	1	Grip	28	117-5388	2	Rod-Hydro
2	121-0730	1	Handle-Control, LH	29	119-8842	2	Mount-Rod, Hydro
2:1	121-0726	1	Grip	30	119-8952	8	Washer
3	3256-24	4	Washer-Flat	31	321-3	2	Screw-HH
4	323-6	4	Screw-HH	32	121-3017	1	Brake Control Module ASM
5	120-7950	2	Screw-Shoulder	33	117-5385	2	Retainer
6	119-3470	2	Actuator Arm ASM	34	32144-1	4	Screw-Taptite
6:2	256-156	2	Bushing-Flange	35	121-2974	1	Rod-Brake, RH
7	110-6810	2	Stud-Damper	36	121-2975	1	Rod-Brake, LH
8	103-2913	2	Damper-Control, Motion	37	117-1169	4	Spring-Compression
9	3296-42	6	Nut-Lock, NI	38	3290-307	2	Pin-Hair
10	104-8300	10	Nut-Flange, NI	39	32144-36	4	Screw-PPH
11	3256-23	2	Washer-Flat	40	1-603807	2	Spring-Return, Neutral
13	104-8301	4	Nut-Flange, NI	41	119-8859	1	Cover-Brake
14	119-8925	2	Washer-Belleville	42	32144-4	1	Screw-HWH
15	117-1240	2	Washer	43	93-6079	2	Spacer-Nylon
16	119-8832	1	Control-Speed	44	119-8935	1	Knob-RH
17	119-3303	2	Pin-Rod, Hydro	45	119-8936	1	Knob-LH
19	117-1198	2	Bolt-Pivot	46	94-4496	1	Screw-PPH
20	125-5473-03	1	Control Box ASM	47	3234-47	6	Screw-HHF
21	3296-56	2	Nut-Lock, NI	48	130-0780	1	Decal-Speed Control
22	115-5098-05	2	Lever-Control	49	32144-70	4	Screw-HWHTF
23	120-2273	2	Washer-Nylon	50	119-8871	1	Decal
26	115-5099	2	Bolt-Pivot				

Belt and Idler Assembly

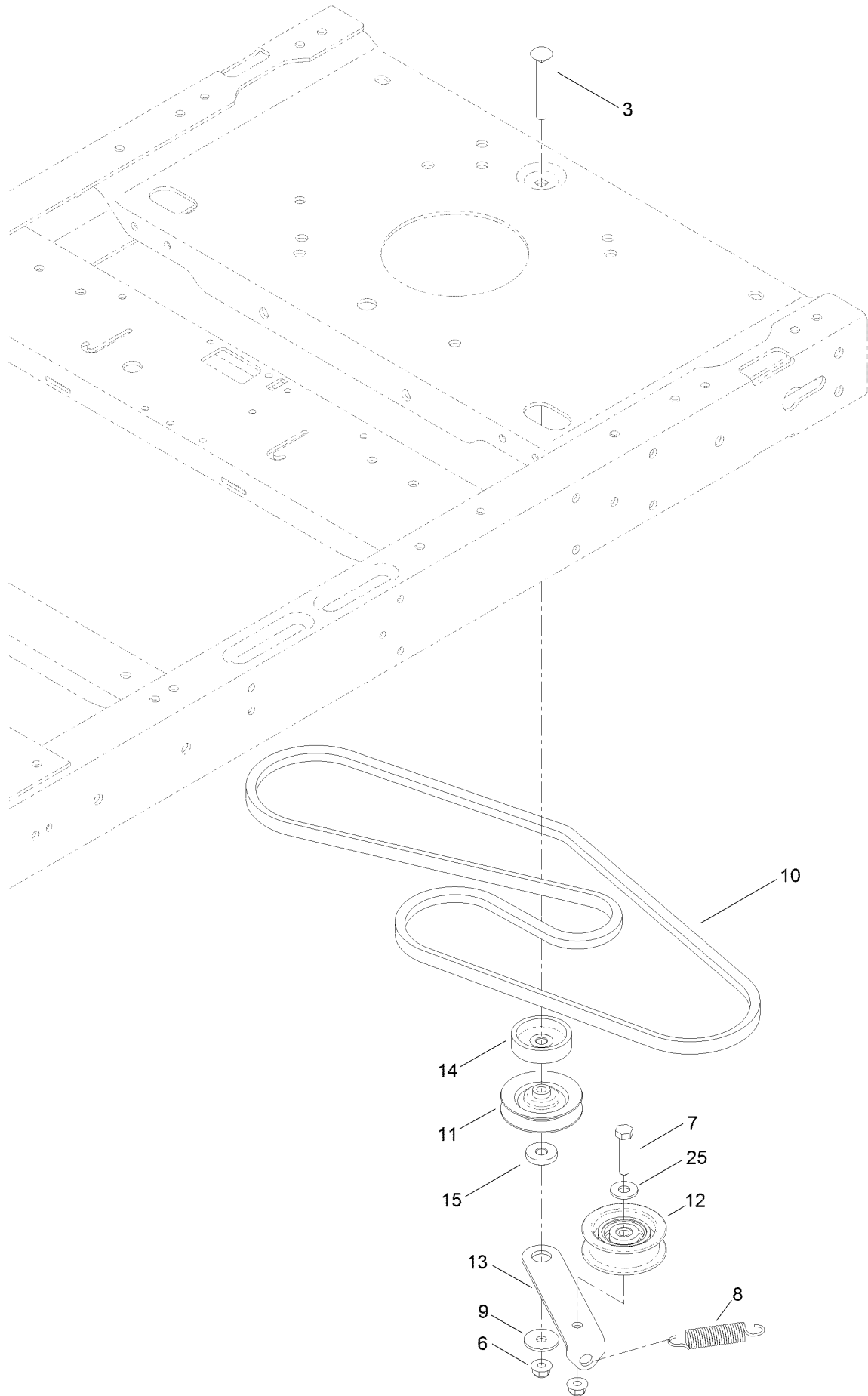

Belt and Idler Assembly (continued)

<i>Ref.</i>	<i>Part Number</i>	<i>Qty.</i>	<i>Description</i>	<i>Ref.</i>	<i>Part Number</i>	<i>Qty.</i>	<i>Description</i>
3	3230-8	1	Screw-CARR	11	119-8822	1	Pulley-Idler
6	104-8300	2	Nut-Flange, NI	12	106-2176	1	Pulley-Idler
7	322-7	1	Screw-HH	13	119-3326	1	Arm-Idler
8	104-6415	1	Spring-Return, Pedal	14	119-3353	1	Spacer
9	5-4460	1	Washer-Pivot	15	119-3327	1	Spacer-Arm, Idler
10	119-3309	1	V-Belt	25	3256-3	1	Washer-Flat

Hydro Transaxle Drive and Rear Wheel Assembly

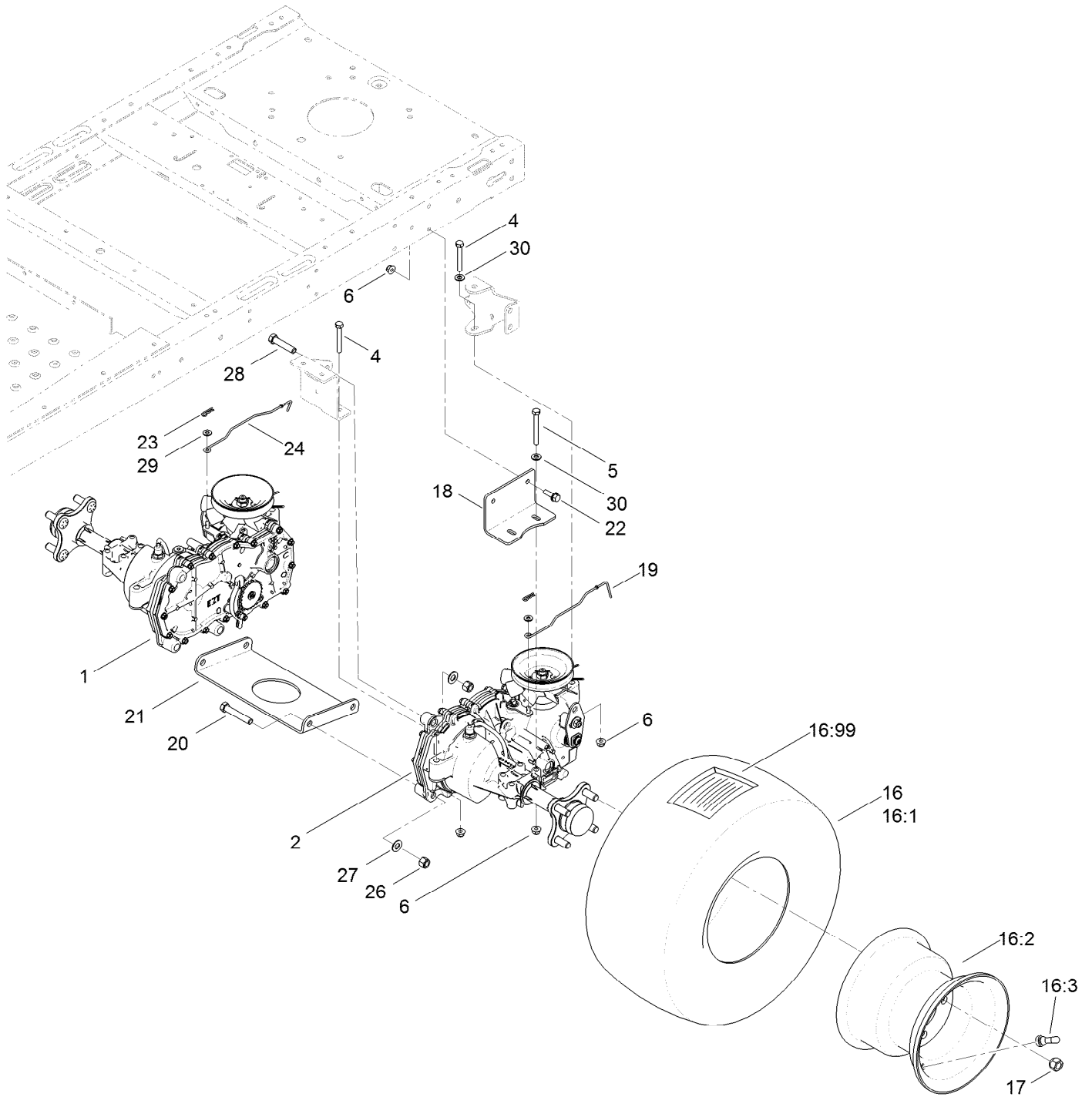

Hydro Transaxle Drive and Rear Wheel Assembly (continued)

<i>Ref.</i>	<i>Part Number</i>	<i>Qty.</i>	<i>Description</i>	<i>Ref.</i>	<i>Part Number</i>	<i>Qty.</i>	<i>Description</i>
1	119-3331	1	RH Hydro Transaxle ASM	19	121-2971	1	Rod-Bypass, LH
2	119-3330	1	LH Hydro Transaxle ASM	20	324-10	4	Screw-HH
4	322-11	4	Screw-HH	21	119-3339-03	1	Plate-Cross, Hydro
5	322-13	4	Screw-HH	22	3234-29	4	Screw-HHF
6	104-8300	12	Nut-Flange, NI	23	3290-307	2	Pin-Hair
16	120-5523	2	Wheel And Tire ASM	24	121-0752	1	Rod-Bypass, RH
16:1	119-8907	1	Tire	26	3296-48	6	Nut-Lock, NI
16:2	107-2475	1	Wheel	27	3256-25	6	Washer-Flat
16:3	232-27	1	Stem-Valve	28	324-8	2	Screw-HH
16:99	107-2491	1	Tube-Tire	29	119-8952	2	Washer
17	242-50	8	Nut-Lug	30	3256-23	6	Washer-Flat
18	117-7264-03	2	Mount-Hydro				

Right Hand Hydro Transaxle Assembly No. 119-3331

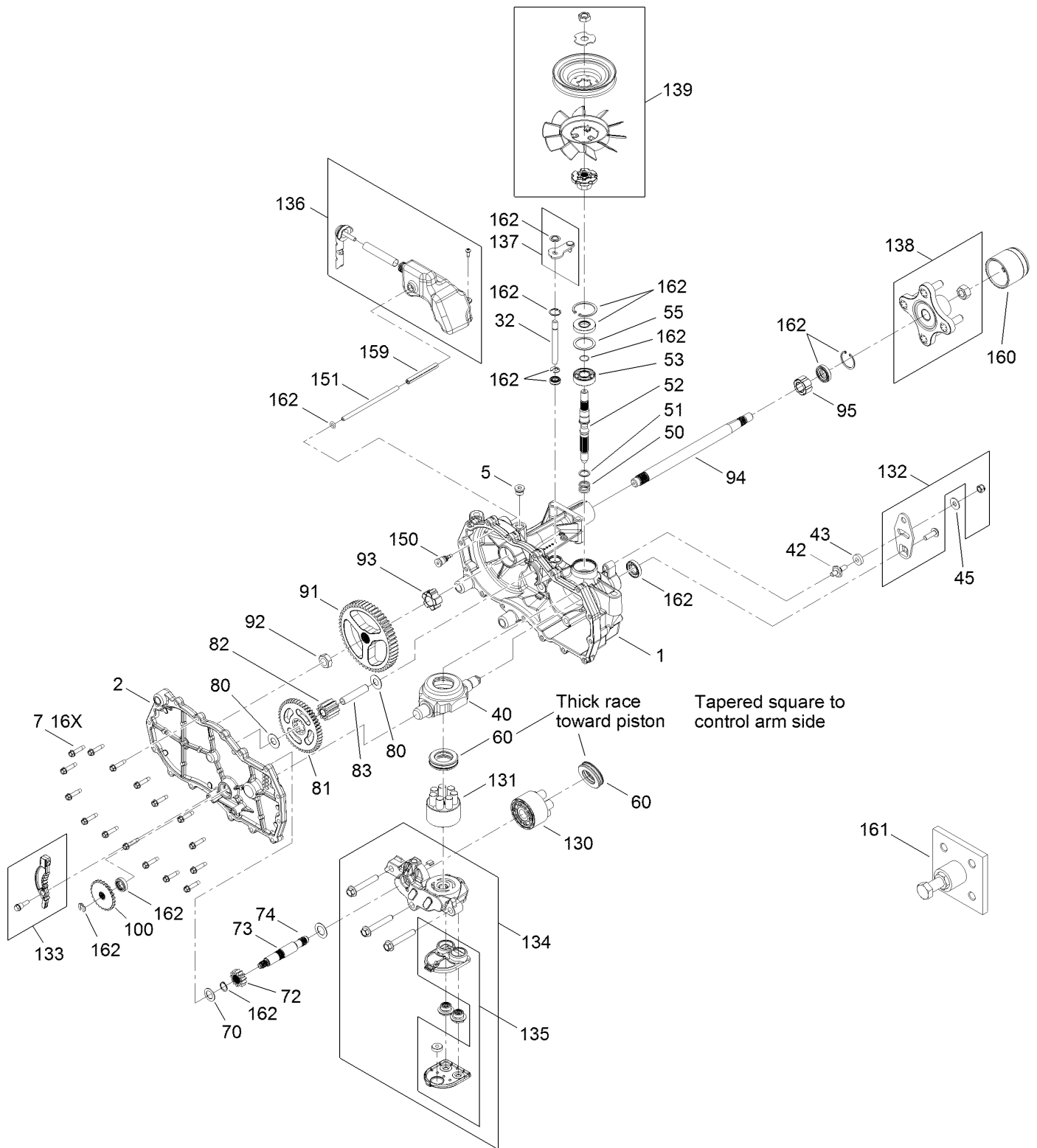

Right Hand Hydro Transaxle Assembly No. 119-3331 (continued)

<i>Ref.</i>	<i>Part Number</i>	<i>Qty.</i>	<i>Description</i>	<i>Ref.</i>	<i>Part Number</i>	<i>Qty.</i>	<i>Description</i>
1	120-5531	1	Main Housing ASM	83	104-5329	1	Pin-Jackshaft
2	120-5533	1	Housing Side Kit	91	120-5539	1	Gear-Bull
5	104-2189	1	Plug-Thread, Straight	92	104-2142	1	Nut-HJ
7	117-5359	16	Screw-HHF	93	115-8314	1	Bushing-Inboard
13	104-2147	1	Sealant ●	94	120-5540	1	Shaft-Axle
32	106-8678	2	Rod-Bypass	95	120-5541	1	Bearing-Sleeve
40	104-5304	1	Swashplate-Trunnion	100	106-8694	1	Disc-Brake, Cog
42	104-2116	1	Stud	130	103-2666	1	Cylinder Block Kit
43	112-9853	1	Puck-Friction	131	110-8561	1	Pump Block ASM
45	114-8491	1	Washer	132	117-5362	1	Arm Control Kit
50	120-5537	1	Spring-Compression	133	106-8688	1	Brake Arm Kit
51	120-5538	1	Washer	134	112-9862	1	Center Section Filter Kit
52	104-5306	1	Shaft-Input	135	114-1634	1	Filter Kit
53	104-5311	1	Bearing-Ball	136	121-5735	1	LH Expansion Tank Kit
55	104-5308	1	Spacer	137	107-2489	1	Bypass Arm Kit
60	94-6922	1	Bearing-Thrust	138	121-5731	1	Hub Kit
70	104-5339	1	Washer-Flat	139	121-5729	1	Fan Pulley Kit
72	104-5316	1	Gear-Pinion, 13T	150	104-5349	1	Fitting-Sae
73	106-8683	1	Shaft-Motor	151	115-8302	1	Hose
74	104-5360	1	Washer	159	121-5728	1	Case-Tube
80	119-5541	2	Washer	160	125-0041	1	Cap-Axle
81	104-5317	1	Gear-10T/48T	161	114-8467	1	Hub-Puller, 4 Bolt
82	104-5318	1	Gear-Jackshaft, 10T	162	120-7103	1	Seal And Ring Kit

● Not illustrated

Left Hand Hydro Transaxle Assembly No. 119-3330

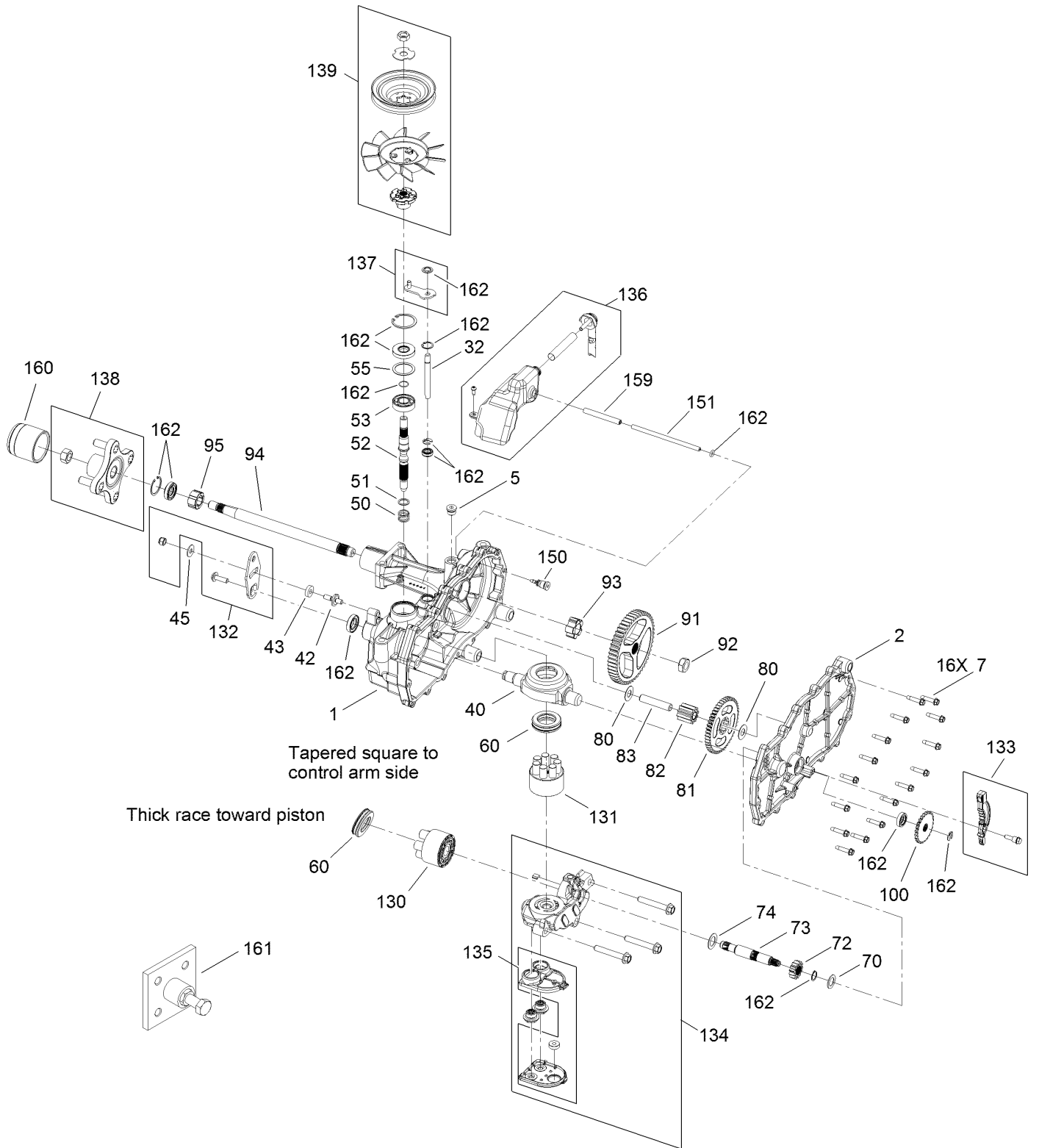

Left Hand Hydro Transaxle Assembly No. 119-3330 (continued)

<i>Ref.</i>	<i>Part Number</i>	<i>Qty.</i>	<i>Description</i>	<i>Ref.</i>	<i>Part Number</i>	<i>Qty.</i>	<i>Description</i>
1	120-5532	1	Main Housing ASM	83	104-5329	1	Pin-Jackshaft
2	120-5534	1	Housing Side Kit	91	120-5539	1	Gear-Bull
5	104-2189	1	Plug-Thread, Straight	92	104-2142	1	Nut-HJ
7	117-5359	16	Screw-HHF	93	115-8314	1	Bushing-Inboard
13	104-2147	1	Sealant ●	94	120-5540	1	Shaft-Axle
32	106-8678	2	Rod-Bypass	95	120-5541	1	Bearing-Sleeve
40	104-5304	1	Swashplate-Trunnion	100	106-8694	1	Disc-Brake, Cog
42	104-2116	1	Stud	130	103-2666	1	Cylinder Block Kit
43	112-9853	1	Puck-Friction	131	110-8561	1	Pump Block ASM
45	114-8491	1	Washer	132	117-5362	1	Arm Control Kit
50	120-5537	1	Spring-Compression	133	106-8688	1	Brake Arm Kit
51	120-5538	1	Washer	134	112-9861	1	Center Section Filter Kit
52	104-5306	1	Shaft-Input	135	114-1634	1	Filter Kit
53	104-5311	1	Bearing-Ball	136	121-5730	1	RH Expansion Tank Kit
55	104-5308	1	Spacer	137	120-5549	1	Bypass Kit
60	94-6922	1	Bearing-Thrust	138	121-5731	1	Hub Kit
70	104-5339	1	Washer-Flat	139	121-5729	1	Fan Pulley Kit
72	104-5316	1	Gear-Pinion, 13T	150	104-5349	1	Fitting-Sae
73	106-8683	1	Shaft-Motor	151	115-8302	1	Hose
74	104-5360	1	Washer	159	121-5728	1	Case-Tube
80	119-5541	2	Washer	160	125-0041	1	Cap-Axle
81	104-5317	1	Gear-10T/48T	161	114-8467	1	Hub-Puller, 4 Bolt
82	104-5318	1	Gear-Jackshaft, 10T	162	120-7103	1	Seal And Ring Kit

● Not illustrated

Clutch Assembly

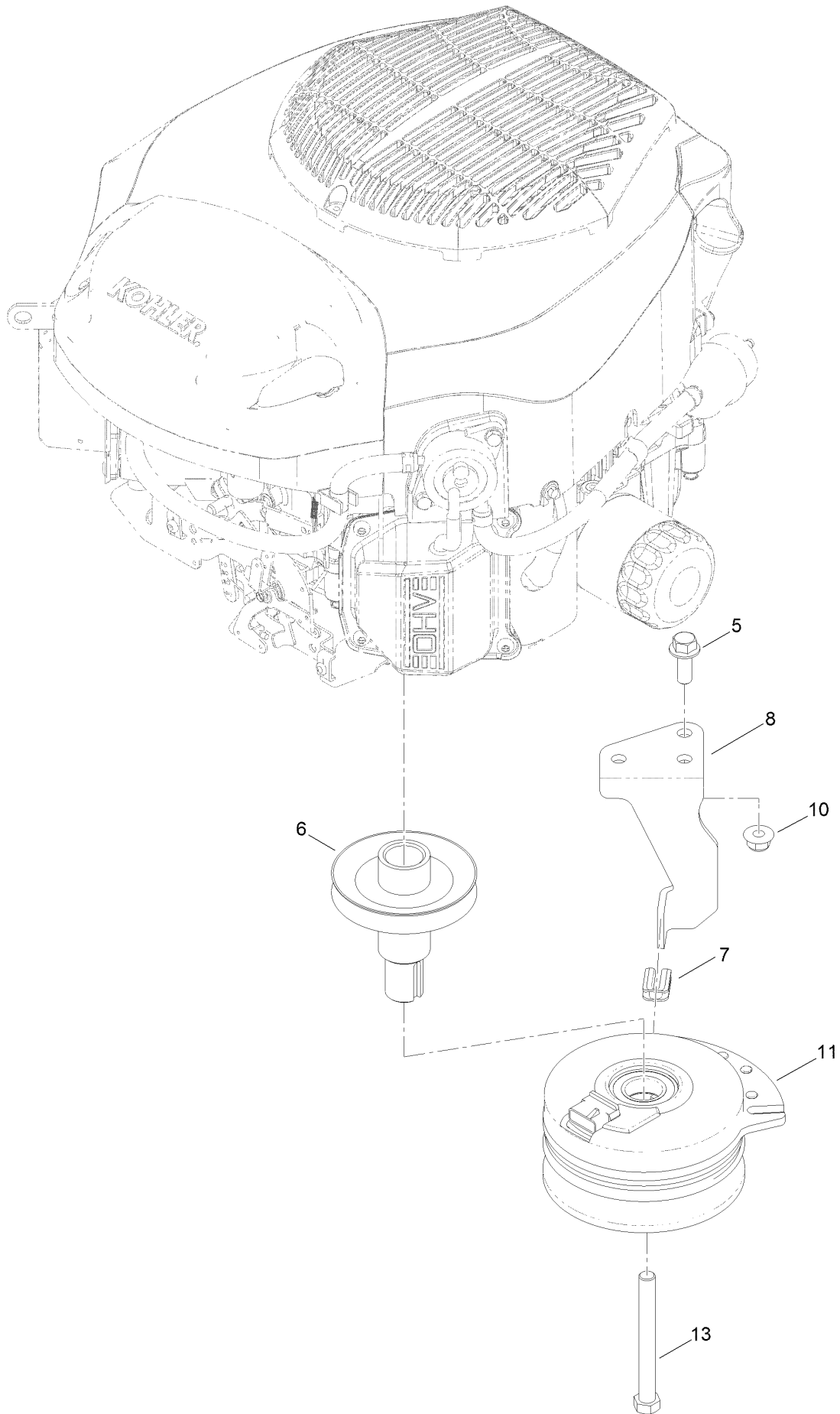

Clutch Assembly (continued)

<i>Ref.</i>	<i>Part Number</i>	<i>Qty.</i>	<i>Description</i>	<i>Ref.</i>	<i>Part Number</i>	<i>Qty.</i>	<i>Description</i>
5	3234-42	1	Screw-HHF	10	104-8301	1	Nut-Flange, NI
6	119-3318	1	Pulley-Engine	11	117-7468	1	Clutch-Electric
7	120-2217	1	Isolator-Clutch	13	3212-16	1	Screw-HH
8	119-8884	1	Stop-Clutch				

Engine and Muffler Assembly

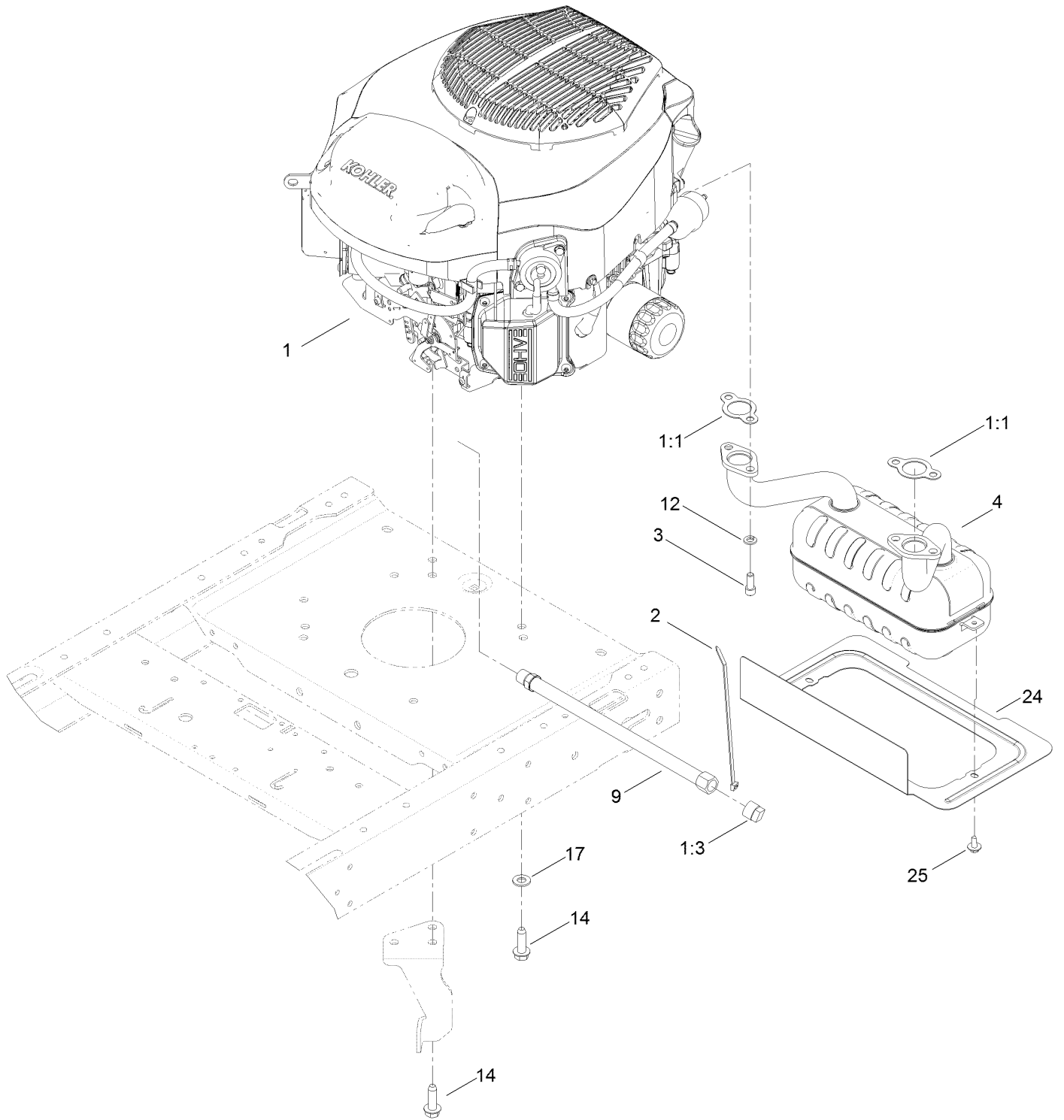

Engine and Muffler Assembly (continued)

<i>Ref.</i>	<i>Part Number</i>	<i>Qty.</i>	<i>Description</i>	<i>Ref.</i>	<i>Part Number</i>	<i>Qty.</i>	<i>Description</i>
1		1	Engine Kohler-Kt730-3024 ●■	9	117-1261	1	Oil Drain Hose ASM
1:1	110-6697	2	Gasket-Exhaust	12	3253-4	4	Washer-Lock
1:3	281-2	1	Plug-Pipe, SQH	14	32144-109	4	Screw-Taptite
2	614249	1	Tie-Cable	17	3256-24	3	Washer-Flat
3	3274-10	4	Screw-HSH	24	121-2973-03	1	Shield-Heat
4	117-7462	1	Muffler-Kohler	25	46-8560	2	Screw-HHFTF

● Not serviced separately

■ Obtain parts from www.kohlerplus.com

Body Styling and Fuel Pod Assembly

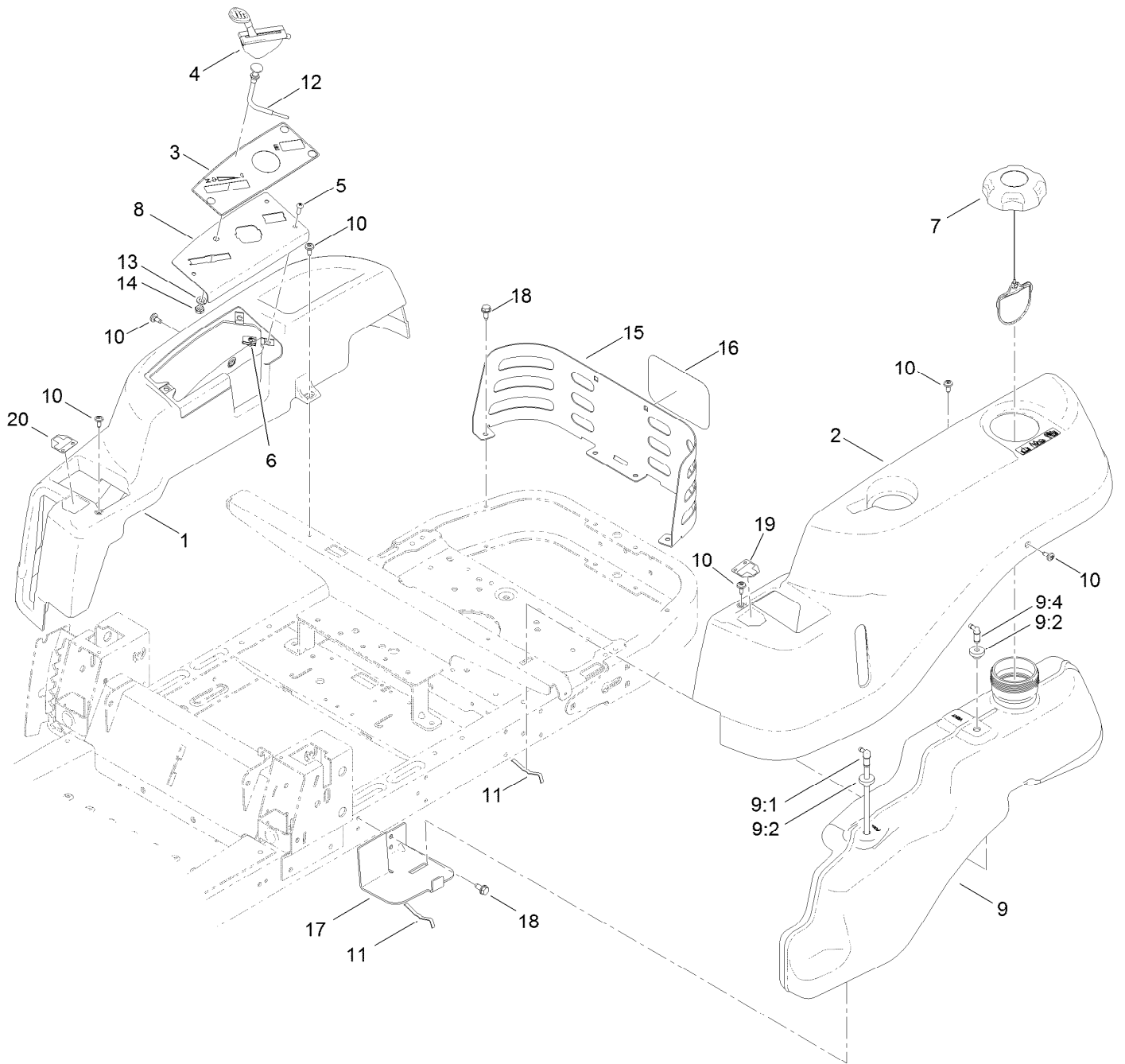

Body Styling and Fuel Pod Assembly (continued)

<i>Ref.</i>	<i>Part Number</i>	<i>Qty.</i>	<i>Description</i>	<i>Ref.</i>	<i>Part Number</i>	<i>Qty.</i>	<i>Description</i>
1	119-3335	1	Pod-RH	10	120-7950	6	Screw-Shoulder
2	119-3334	1	Pod-LH	11	609830	2	Spring
3	121-0772	1	Decal-Panel, Control	12	110-6754	1	Cable-Choke
4	121-5674	1	Cable-Throttle	13	3253-21	1	Washer-Lock
5	3258-166	3	Screw-PRH	14	3220-3	1	Nut-HJ
6	107069	3	Clip	15	119-8855-03	1	Guard-Rear
7	120-5461	1	Cap-Fuel, Ratcheting	16	105-8278	1	Decal
8	119-3378-03	1	Plate-Control	17	119-3476-03	1	Support-Tank, Front
9	119-3324	1	Fuel Tank ASM	18	32144-70	6	Screw-HWHTF
9:1	121-0793	1	Connector-Elbow, 90 DEG	19	119-8814	1	Decal-Control Lever, LH
9:2	46-6560	2	Bushing	20	119-8815	1	Decal-Control Lever, RH
9:4	117-7400	1	Fitting-Plastic				

Fuel Delivery Assembly

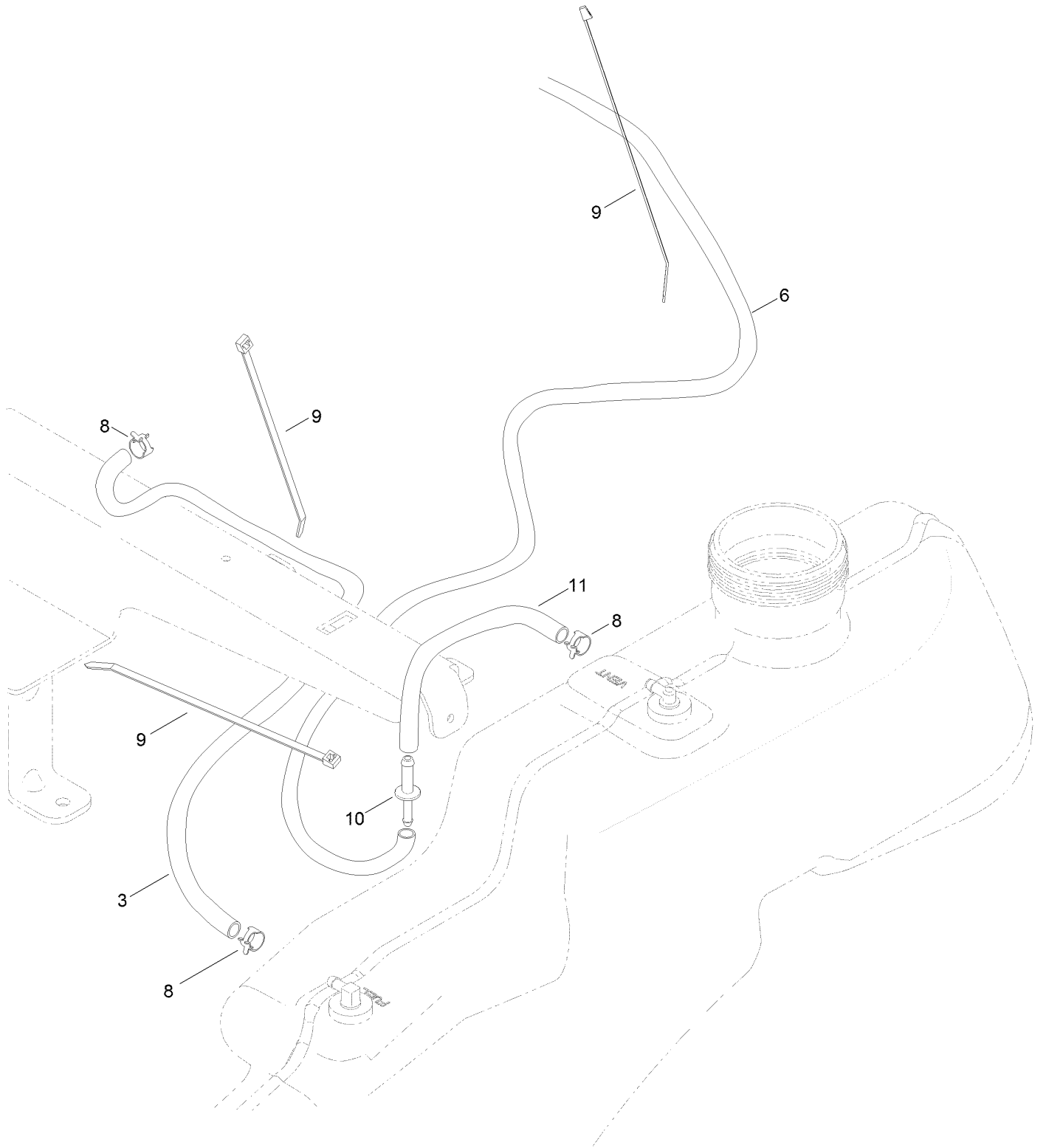

Fuel Delivery Assembly (continued)

<i>Ref.</i>	<i>Part Number</i>	<i>Qty.</i>	<i>Description</i>	<i>Ref.</i>	<i>Part Number</i>	<i>Qty.</i>	<i>Description</i>
3	109-0301	1	Hose-Fuel	9	614249	3	Tie-Cable
6	51-3212	1	Hose-Fuel	10	117-5399	1	Adaptor-Orifice
8	2412-98	3	Clamp-Hose	11	110-1876	1	Hose-Fuel

Battery and Electrical Assembly

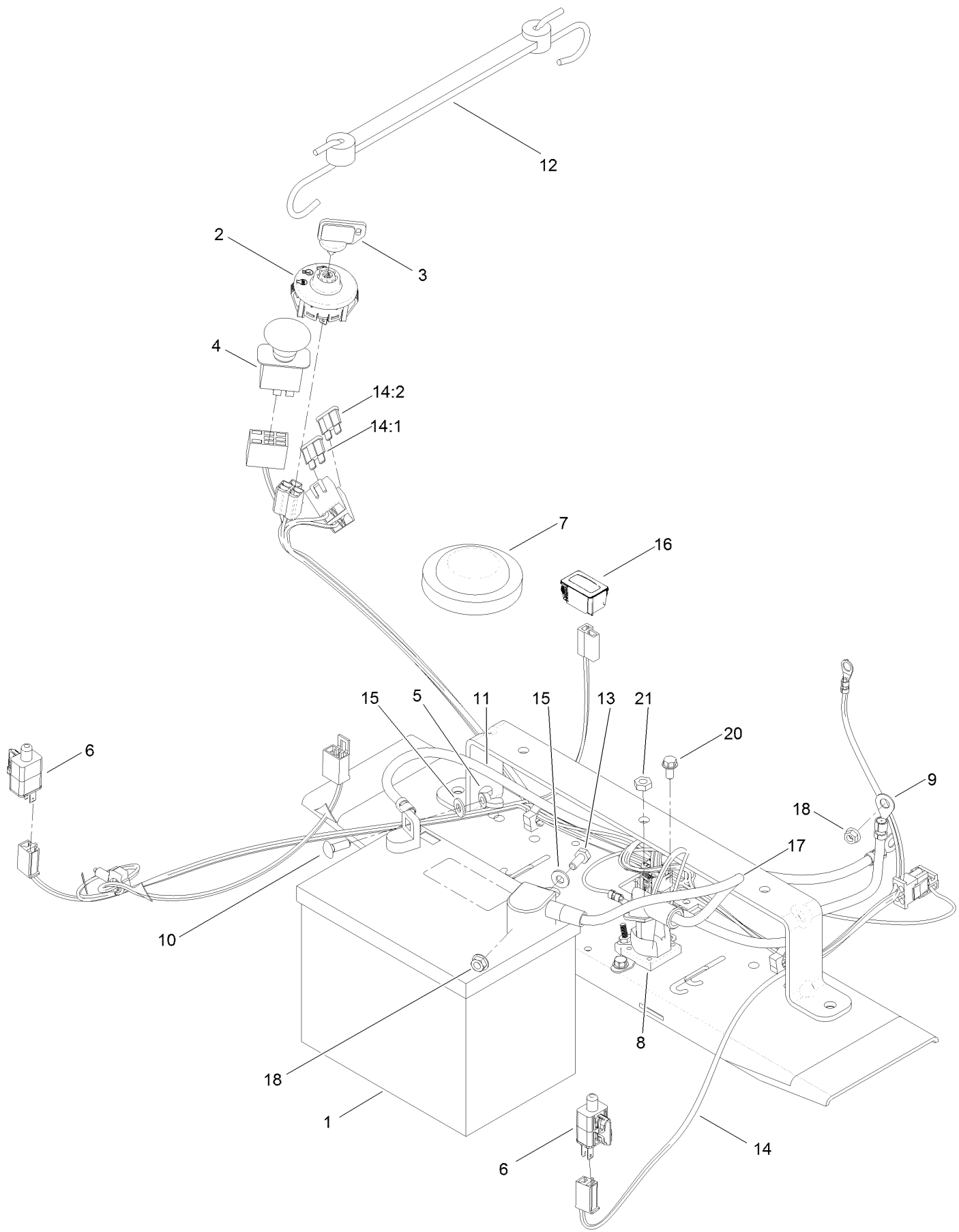

Battery and Electrical Assembly (continued)

<i>Ref.</i>	<i>Part Number</i>	<i>Qty.</i>	<i>Description</i>	<i>Ref.</i>	<i>Part Number</i>	<i>Qty.</i>	<i>Description</i>
1	105-1692	1	Battery	12	104-2466	1	Holddown-Battery
2	117-2221	1	Switch-Ignition	13	321-3	1	Screw-HH
3	63-8360	1	Key-Ignition	14	121-5652	1	Harness-Wire
4	103-5221	1	Switch-PTO	14:1	109103	1	Fuse-Blade, 30 Amp
5	32103-22	1	Nut-Wing	14:2	109102	1	Fuse-Blade, 25 Amp
6	110-6765	2	Switch	15	3256-22	2	Washer-Flat
7	100-3524	1	Switch-Seat	16	120-2244	1	Hourmeter
8	117-1197	1	Solenoid	17	119-8897	1	Cable-Battery, Red
9	121-0711	1	Cable-Battery, Positive	18	32128-33	2	Nut-HF
10	3229-1	1	Bolt-CARR	20	32144-4	2	Screw-HWH
11	121-5726	1	Cable-Battery, Black	21	3220-2	2	Nut-Jam

Fuel Delivery Assembly

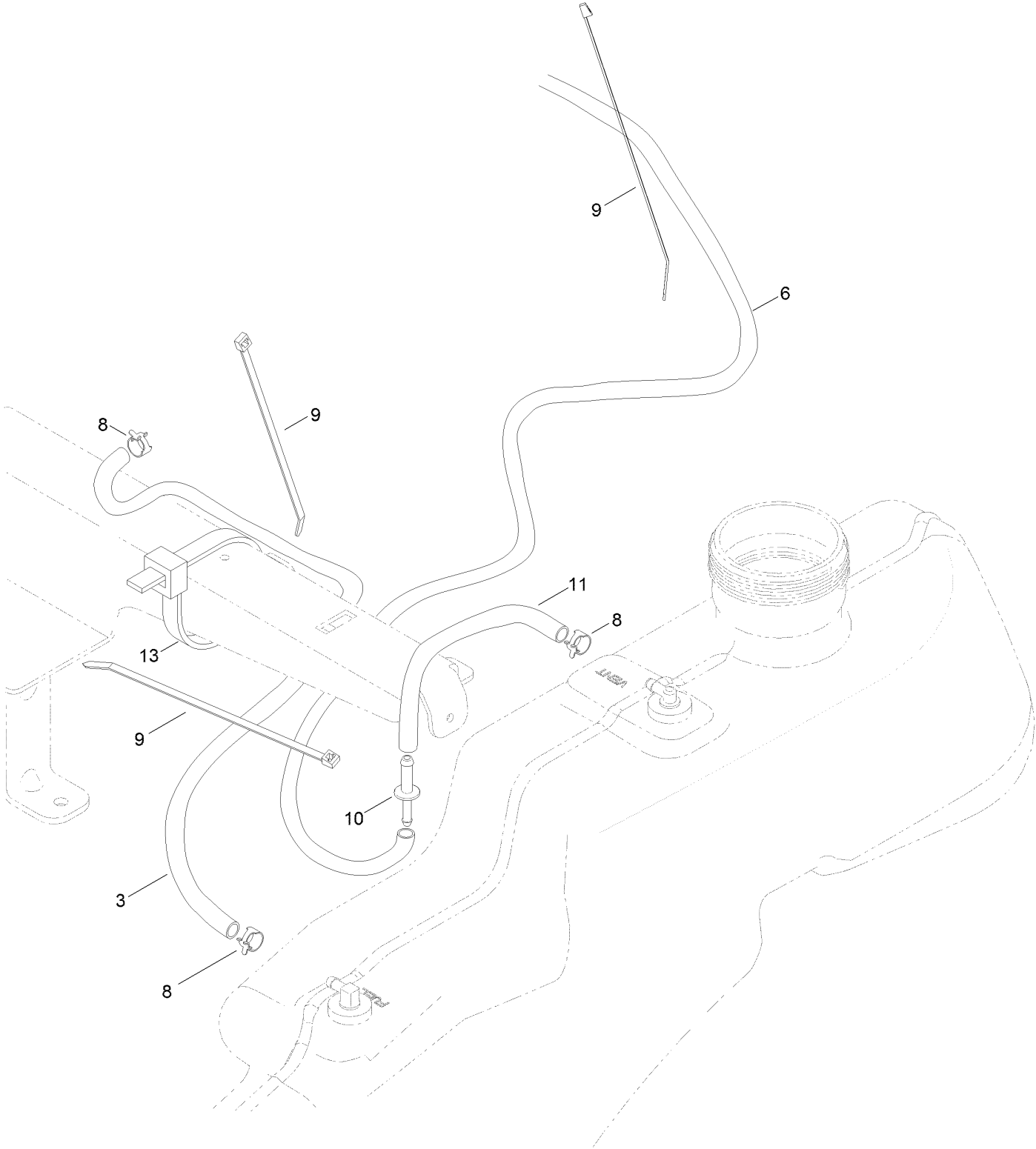

Fuel Delivery Assembly (continued)

<i>Ref.</i>	<i>Part Number</i>	<i>Qty.</i>	<i>Description</i>	<i>Ref.</i>	<i>Part Number</i>	<i>Qty.</i>	<i>Description</i>
3	109-0273	1	Hose-Fuel	10	117-5399	1	Adaptor-Orifice
6	108-9698	1	Hose-Fuel	11	110-1876	1	Hose-Fuel
8	2412-98	3	Clamp-Hose	13	3334-945	2	Tie-Cable
9	614249	3	Tie-Cable				

Seat Assembly

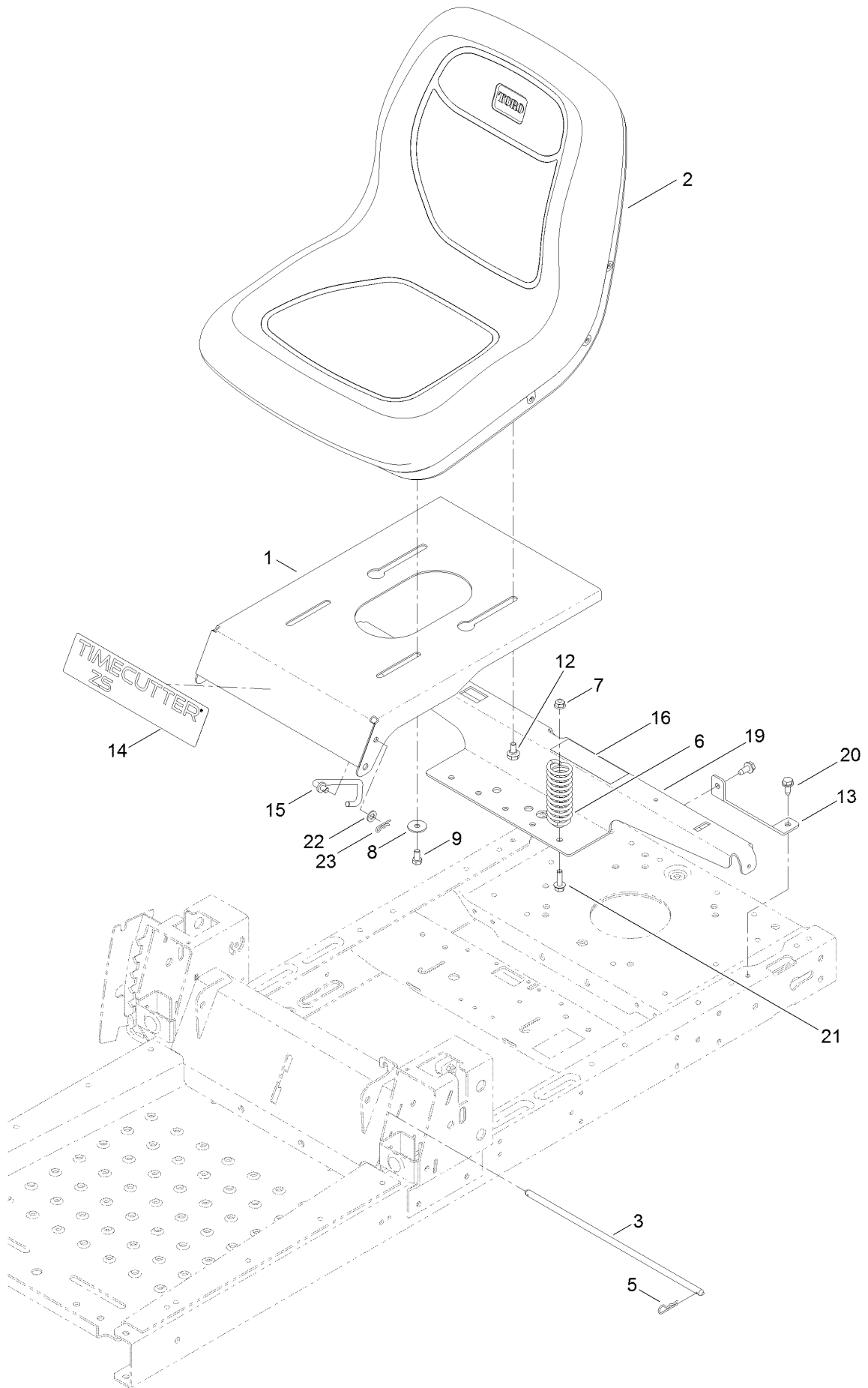

Seat Assembly (continued)

<i>Ref.</i>	<i>Part Number</i>	<i>Qty.</i>	<i>Description</i>	<i>Ref.</i>	<i>Part Number</i>	<i>Qty.</i>	<i>Description</i>
1	119-3391-01	1	Pan-Seat	13	119-3431-03	2	Support-Tank, Rear
2	119-8829	1	Seat-18 Inch	14	120-5459	1	Decal-Timecutter
3	119-3433	1	Rod-Pivot, Narrow	15	119-8972	1	Stop-Seat
5	3290-250	2	Pin-Hair	16	106-8717	1	Decal-Service
6	92-7054	3	Spring-Compression	19	121-0732-03	1	Support-Pod
7	104-8300	3	Nut-Flange, NI	20	32144-70	4	Screw-HWHTF
8	5-4460	2	Washer-Pivot	21	3234-29	3	Screw-HHF
9	322-2	2	Screw-HH	22	3256-23	1	Washer-Flat
12	37-8771	2	Bolt-Shoulder	23	3290-307	1	Pin-Hair

Deck Lift Assembly

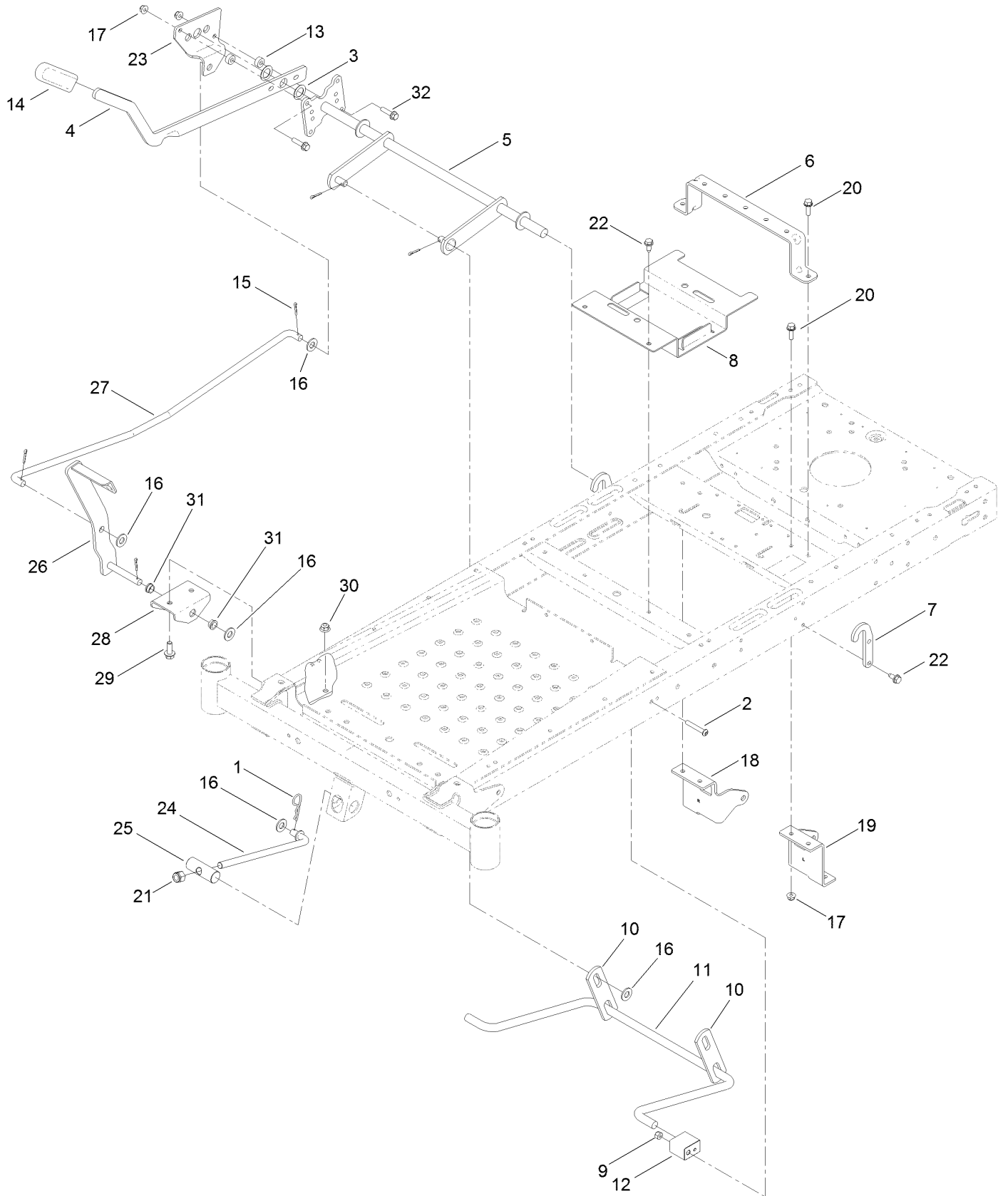

Deck Lift Assembly (continued)

<i>Ref.</i>	<i>Part Number</i>	<i>Qty.</i>	<i>Description</i>	<i>Ref.</i>	<i>Part Number</i>	<i>Qty.</i>	<i>Description</i>
1	1-806005	1	Pin-Hair	17	104-8300	6	Nut-Flange, NI
2	120-5499	2	Screw-HSBH	18	119-8861-01	1	Mount-Hydro, Front (RH)
3	3-6498	2	Washer-Thrust	19	119-8862-01	1	Mount-Hydro, Front (LH)
4	119-3427-03	1	Lever-Lift	20	3234-29	4	Screw-HHF
5	117-7346-03	1	Lift-Deck	21	3296-19	1	Nut-Hex
6	119-3435-03	1	Brace-Seat, Rear	22	32144-70	6	Screw-HWHTF
7	119-8875	2	Bracket-Lift	23	120-2275	1	Plate-Footlift
8	119-3406-03	1	Bracket-Battery	24	104-8047	1	Rod-Trunion
9	3296-29	2	Nut-Lock, NI	25	119-8810	1	Pin-Pivot
10	108-7840	2	Link-Lift	26	120-2276-03	1	Pedal
11	108-7839	1	Arm-Lift, Rear	27	120-2242	1	Rod-Footlift
12	108-7845	2	Block-Pivot	28	120-2294-03	1	Bracket-Footlift
13	121-1759	2	Spacer	29	3234-42	2	Screw-HHF
14	1-633268	1	Grip-Lever	30	104-8301	2	Nut-Flange, NI
15	3272-10	5	Pin-Cotter	31	256-156	2	Bushing-Flange
16	3256-26	6	Washer-Flat	32	3234-36	2	Screw-HHF

42 Inch Deck Assembly

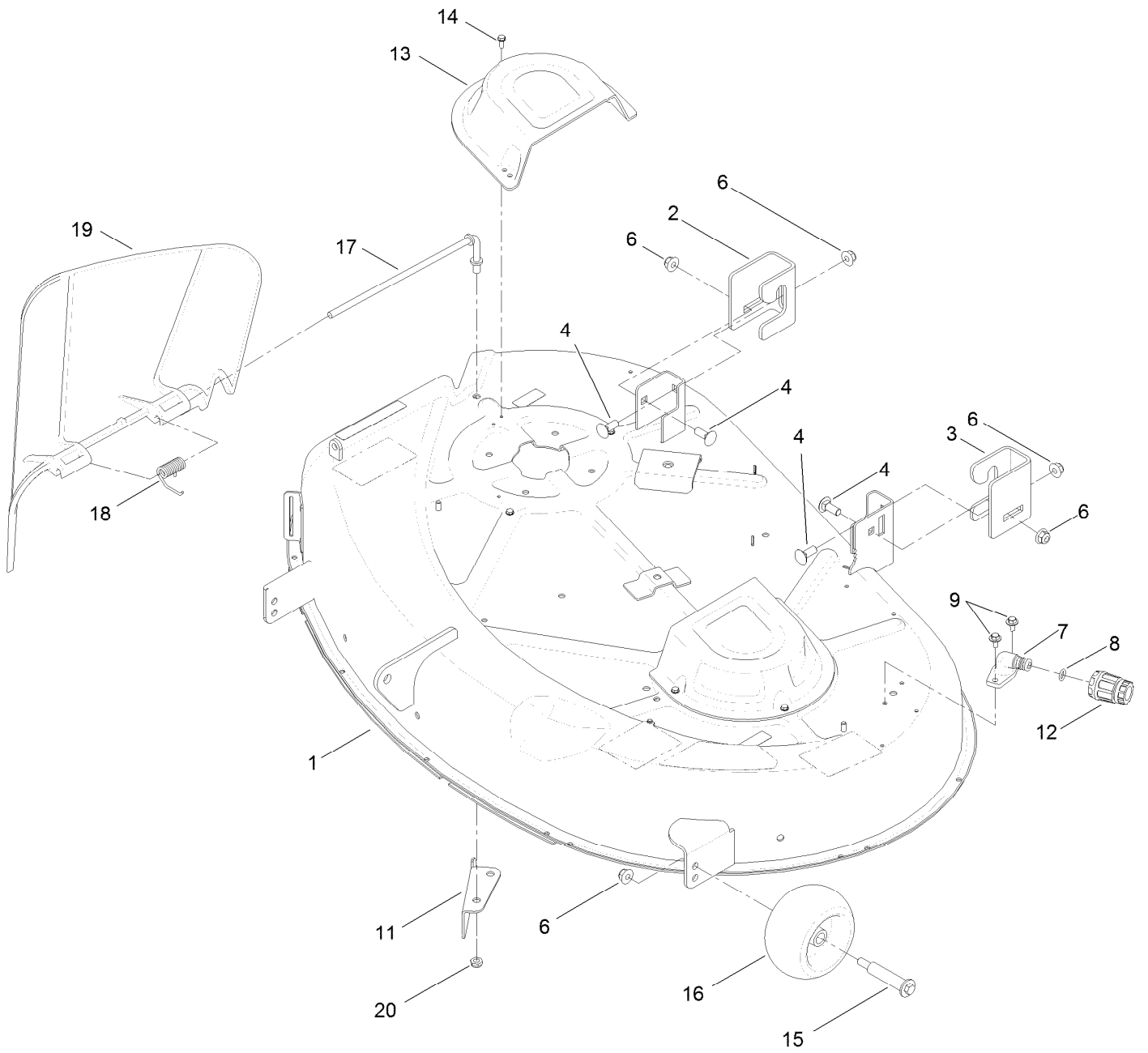

42 Inch Deck Assembly (continued)

<i>Ref.</i>	<i>Part Number</i>	<i>Qty.</i>	<i>Description</i>	<i>Ref.</i>	<i>Part Number</i>	<i>Qty.</i>	<i>Description</i>
1	119-8840	1	42 Inch Deck And Decal ASM	12	95-3270	1	Connector-Hose
2	119-3494	1	Bracket-Hanger, RH	13	108-7889	2	Cover-Belt
3	119-3496	1	Bracket-Hanger, LH	14	32144-1	6	Screw-Taptite
4	3231-2	4	Bolt-CARR	15	112-3977	2	Bolt-Shoulder
6	104-8301	6	Nut-Flange, NI	16	1-603299	2	Roller-Scalp, Anti
7	95-2747	1	Fitting-Washout	17	112-4026	1	Rod-Pivot
8	46-6290	1	O-Ring, Seal	18	110-6694	1	Spring-Torsion
9	46-8560	2	Screw-HHFTF	19	112-3951	1	Deflector
11	112-3983-03	1	Baffle-Cutoff	20	3296-59	1	Nut-Lock, NI

42 Inch Deck Assembly No. 119-8840

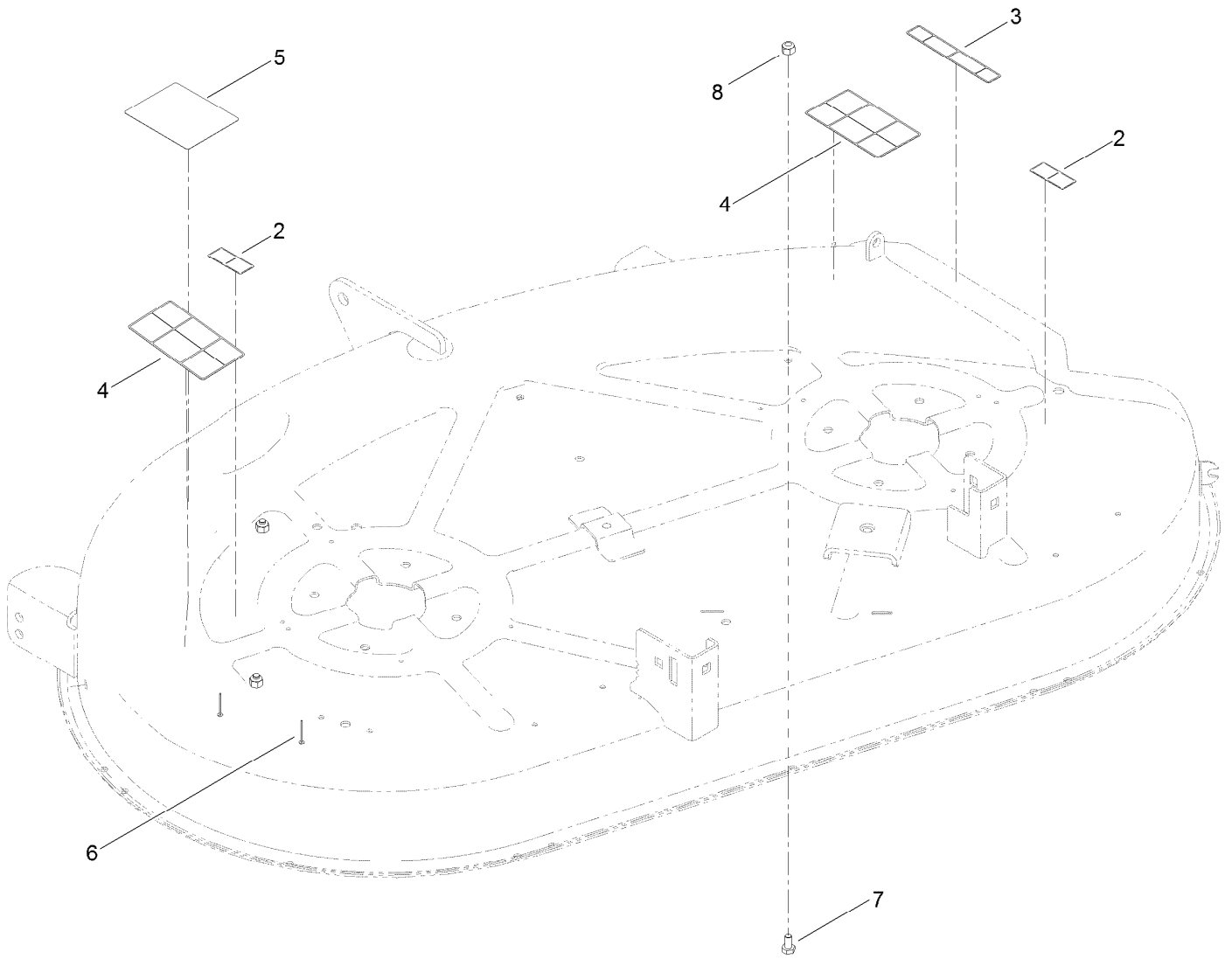

42 Inch Deck Assembly No. 119-8840 (continued)

<i>Ref.</i>	<i>Part Number</i>	<i>Qty.</i>	<i>Description</i>	<i>Ref.</i>	<i>Part Number</i>	<i>Qty.</i>	<i>Description</i>
2	114-1606	2	Decal-Danger	6	3290-282	2	Rivet-Blind
3	93-7009	1	Decal-Danger	7	321-2	3	Screw-HH
4	110-6691	2	Decal-Danger	8	3296-42	3	Nut-Lock, NI
5	105-7015	1	Decal-Routing, Belt				

42 Inch Deck, Belt and Blade Assembly

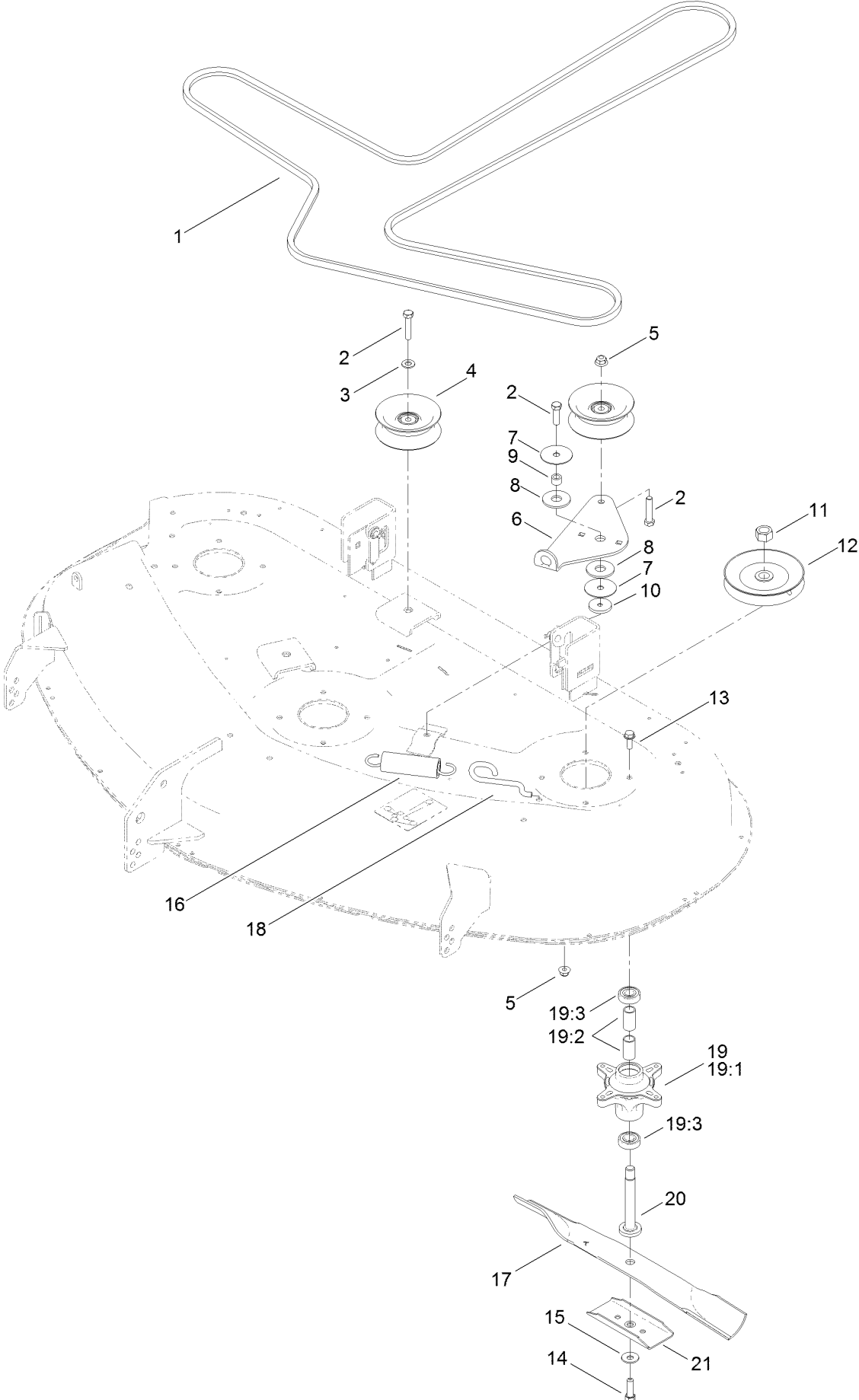

42 Inch Deck, Belt and Blade Assembly (continued)

<i>Ref.</i>	<i>Part Number</i>	<i>Qty.</i>	<i>Description</i>	<i>Ref.</i>	<i>Part Number</i>	<i>Qty.</i>	<i>Description</i>
1	119-8819	1	V-Belt	13	32144-41	8	Screw-Taptite
2	323-9	2	Screw-HH	14	26-0671	2	Screw-HH
3	3256-24	1	Washer-Flat	15	3290-465	2	Washer-Belleville
4	106-2175	2	Pulley-Idler, Flat	16	106-2177	1	Spring-Extension
5	104-8301	1	Nut-Flange, NI	17	110-6568-03	2	Blade-21.6 Inch
6	114-8540	1	Arm-Idler	18	88-5970	1	Hook-Return, Spring
7	120-2229	2	Washer-Idler Pivot	19	121-0751	2	Spindle ASM
8	114-0463	2	Washer-Friction, Composite	19:1	117-7267	1	Spindle
9	115-4986	1	Spacer	19:2	120-7935	2	Spacer
10	323-7	1	Screw-HH	19:3	100-1048	2	Bearing-Ball
11	3219-6	2	Nut-Hex	20	117-7268	2	Shaft-Spindle
12	125-5574	2	Pulley	21	106-2248-03	2	Stiffener-Blade

Attachments and Accessories

For 74636 TimeCutter SS 4260 Riding Mower

Product Name	Model/Part
Armrest Kit (Milsco)	105-6978
42in Blowout Ring Kit.....	114-1620
Striping Kit	120-7905
Sunshade Kit, 2011 and After Zero-Turn-Radius Riding Mower	79011
42in Recycler Kit, 2007 and After Riding Mower	79018
Cargo Carrier	79030
Front Weight Kit	79031
42in Replacement Blade Kit.....	79220
Storage Cover	79317
42in Bagger, 2011 and After TimeCutter 4000 Series Riding Mower	79334
42in Bagger	79336

Notes:

Notes:

Notes:



Count on it.