



Count on it.

Operator's Manual

LT3340 Heavy-Duty Triple Turf Mower Traction Unit

Model No. 30657—Serial No. 313000001 and Up



g014494



This product complies with all relevant European directives, for details please see the separate product specific Declaration of Conformity (DOC) sheet.

Introduction

This machine is a ride-on, cutterhead-blade lawn mower intended to be used by professional, hired operators in commercial applications. It is primarily designed for cutting grass on parks, sports fields, caravan parks, cemeteries and commercial grounds. It is not designed for cutting brush or for agricultural use.

Read this information carefully to learn how to operate and maintain your product properly and to avoid injury and product damage. You are responsible for operating the product properly and safely.

You may contact Toro directly for product and accessory information, help finding a dealer, or to register your product at Toro Commercial Products Service Department Spellbrook, Bishops Stortford, CM23 4BU, England, +44(0)1279 603019, Email: uk.service@toro.com.

Whenever you need service, genuine Toro parts, or additional information, contact an Authorized Service Dealer or Toro Customer Service and have the model and serial numbers of your product ready. The model and serial numbers are on a plate mounted on the left side of the frame under the foot rest. Write the numbers in the space provided.

Model No. _____
Serial No. _____

This manual identifies potential hazards and has safety messages identified by the safety alert symbol (Figure 1), which signals a hazard that may cause serious injury or death if you do not follow the recommended precautions.



Figure 1

1. Safety alert symbol

This manual uses 2 other words to highlight information. **Important** calls attention to special mechanical information and **Note** emphasizes general information worthy of special attention.

Contents

Introduction	2	Check Battery Condition	38
Safety	4	Inspect Transmission Control Cable and Operating Mechanism	38
Safe Operating Practices	4	Servicing the Battery	39
Toro Riding Mower Safety	6	Drive System Maintenance	39
Sound Power Level	6	Changing the Transmission Oil Filter	39
Sound Pressure Level	6	Changing the Hydraulic Return Filter	39
Safety and Instructional Decals	7	Check Rear Wheel Alignment	40
Setup	10	Cooling System Maintenance	40
Checking the Tyre Pressure	10	Removing Debris from the Cooling System	40
Product Overview	11	Brake Maintenance	41
Controls	11	Towing the Mower	41
Specifications	18	Belt Maintenance	43
Attachments/Accessories	18	Tensioning the Alternator Belt	43
Operation	19	Controls System Maintenance	44
Checking the Engine Oil Level	19	Check Forward/Reverse Travel Pedal Action	44
Checking the Cooling System	20	Operator Presence Seat Switch	44
Adding Fuel	20	Cutter Drive Interlock Switch	44
Checking the Hydraulic Fluid	21	Parking Brake Interlock Switch	44
Check the Torque of the Wheel Nuts	22	Transmission Neutral Interlock Switch	44
Operator Platform Latching Mechanism	22	Hydraulic System Maintenance	45
Operator Presence Control	22	Service the Hydraulic System	45
Starting and Stopping the Engine	23	Check the Hydraulic Oil Overheat Warning System	45
Checking the Cylinder to Bedknife Contact	24	Checking the Hydraulic Lines and Hoses	46
Cutterheads General Information	24	Cutterheads System Maintenance	46
MK3 Fixed cutterhead 8 inch (20 cm) and Fixed cutterhead 10 inch (25 cm)	25	Cutterheads Maintenance	46
MK3 Floating Cutterhead 8 inch (20 cm)	26	Cutterhead Cylinder to Bottom Blade Adjustment	47
Centre Cutterhead Height of Cut Correction Adjustment	27	Cutterheads Back Lapping	48
Cutterhead Position Control	27	Cutterheads Grinding	49
Adjusting the Cutterhead Auto Limited Lift	27	Cutterheads Bottom Blade Replacement	49
Engaging the Cutterhead Drive	28	Raising The Mower Off The Ground	49
Clearing the Cutting Cylinders	28	Waste Disposal	50
Using Weight Transfer/Traction Assistance	28	Storage	50
Folding the R.O.P.S.	29	Preparing the Traction Unit	50
Jacking Points	29	Preparing the Engine	50
Operating Tips	30	Troubleshooting	51
Maintenance	31	Schematics	55
Recommended Maintenance Schedule(s)	31		
Daily Maintenance Checklist	32		
Pre- Maintenance	33		
Service Interval Chart	33		
Lubrication	34		
Greasing the Bearings, Bushings and Pivots	34		
Engine Maintenance	35		
Check the Engine Overheat Warning System	35		
Servicing the Air Cleaner	35		
Servicing the Engine Oil and Filter	36		
Fuel System Maintenance	37		
Draining the Fuel Tank	37		
Checking the Fuel Lines and Connections	37		
Bleeding the Fuel System	37		
Replacing the Fuel Filter	37		
Electrical System Maintenance	38		
Check Electrical System	38		

Safety

This machine meets or exceeds standard EN 836:1997 specifications in effect at time of production.

Improper use or maintenance by the operator or owner can result in injury. To reduce the potential for injury, comply with these safety instructions and always pay attention to the safety alert symbol, which means Caution, Warning, or Danger—personal safety instruction. Failure to comply with the instruction may result in personal injury or death.

Safe Operating Practices

The following instructions are from the standard EN 836:1997.

Training

- Read the operator's manual and other training material carefully. Be familiar with the controls, safety signs, and the proper use of the equipment.
- Never allow children or people unfamiliar with these instructions to use or service the mower. Local regulations may restrict the age of the operator.
- Never mow while people, especially children, or pets are nearby.
- Keep in mind that the operator or user is responsible for accidents or hazards occurring to other people or their property.
- Do not carry passengers.
- All drivers and mechanics should seek and obtain professional and practical instruction. The owner is responsible for training the users. Such instruction should emphasize:
 - the need for care and concentration when working with ride-on machines;
 - control of a ride-on machine sliding on a slope will not be regained by the application of the brake. The main reasons for loss of control are:
 - ◇ insufficient wheel grip;
 - ◇ being driven too fast;
 - ◇ inadequate braking;
 - ◇ the type of machine is unsuitable for its task;
 - ◇ lack of awareness of the effect of ground conditions, especially slopes;
- The owner/user can prevent and is responsible for accidents or injuries occurring to himself or herself, other people, or property.

Preparation

- While mowing, always wear substantial footwear, long trousers, hard hat, safety glasses, and ear protection. Long

hair, loose clothing, or jewelry may get tangled in moving parts. Do not operate the equipment when barefoot or wearing open sandals.

- Thoroughly inspect the area where the equipment is to be used and remove all objects which may be thrown by the machine.
- **Warning**—Fuel is highly flammable. Take the following precautions:
 - Store fuel in containers specifically designed for this purpose.
 - Refuel outdoors only and do not smoke while refuelling.
 - Add fuel before starting the engine. Never remove the cap of the fuel tank or add fuel while the engine is running or when the engine is hot.
 - If fuel is spilled, do not attempt to start the engine but move the machine away from the area of spillage and avoid creating any source of ignition until fuel vapors have dissipated.
 - Replace all fuel tanks and container caps securely.
- Replace faulty silencers/mufflers.
- Only use accessories and attachments approved by the manufacturer.
- Before using, always visually inspect to see that the blades, blade bolts and cutter assembly are not worn or damaged. Replace worn or damaged blades and bolts in sets to preserve balance.
- On multi-bladed machines, take care as rotating one blade can cause other blades to rotate.
- Check that the operator's presence controls, safety switches and shields are attached and functioning properly. Do not operate unless they are functioning properly.

Operation

- Do not operate the engine in a confined space where dangerous carbon monoxide fumes can collect.
- Mow only in daylight or in good artificial light.
- Before attempting to start the engine, engage the parking brake, disengage the cutterhead drive system and ensure that the forward/reverse speed controls are in the neutral position.
- Do not use on a slope of more than 20 degrees. Care should be taken when using the mower on any slope where ground conditions are such that there may be a risk of the mower rolling over. The requirements of 89/355/EEC, as amended by 95/63/EEC 'Provision and Use of Work Equipment Directive' should be considered.
- Remember there is no such thing as a safe slope. Travel on grass slopes requires particular care. To guard against overturning:
 - do not stop or start suddenly when going up or downhill;

- machine speeds should be kept low on slopes and during tight turns;
- stay alert for humps and hollows and other hidden hazards;
- Do not turn sharply. Use care when reversing.
- Stay alert for holes in the terrain and other hidden hazards.
- Watch out for traffic when crossing or near roadways.
- Stop the blades rotating before crossing surfaces other than grass.
- When using any attachments, never direct discharge of material toward bystanders nor allow anyone near the machine while in operation.
- Never operate the machine with damaged guards, shields, or without safety protective devices in place. Be sure all interlocks are attached, adjusted properly, and functioning properly.
- Do not change the engine governor settings or over-speed the engine. Operating the engine at excessive speed may increase the hazard of personal injury.
- Before leaving the operator's position:
 - stop on level ground;
 - disengage the drive to the cutterheads;
 - lift cutterheads to the transport position and securely lock the safety latches or alternatively lower cutterheads to the ground;
 - Ensure the transmission is in neutral and engage the parking brake;
 - stop the engine and remove the key.
- When transporting the mower:
 - disengage the drive to the cutterheads;
 - raise the cutterheads to the transport position;
 - engage the transport latches and safety locking rings.
 - stop the engine and remove the key.
- When driving the mower between work sites it is important to ensure that the cutterheads cannot be inadvertently lowered and started:
 - disengage the drive to the cutterheads;
 - raise the cutterheads to the transport position;
 - engage the transport latches and safety locking rings.
- Stop the engine and disengage drive to the cutterheads:
 - before refuelling;
 - before making height adjustment unless adjustment can be made from the operator's position.
 - before clearing blockages;
 - before checking, cleaning or working on the mower;
 - after striking a foreign object or if an abnormal vibration occurs. Inspect the mower for damage and make repairs before restarting and operating the equipment.
- Reduce the throttle setting during engine run-out and, if the engine is provided with a shut-off valve, turn the fuel off at the conclusion of mowing.
- Keep hands and feet away from the cutting units.
- Look behind and down before backing up to be sure of a clear path.
- Slow down and use caution when making turns and crossing roads and sidewalks. Stop cylinders/cutterheads if not mowing.
- Do not operate the mower under the influence of alcohol or drugs.
- Lightning can cause severe injury or death. If lightning is seen or thunder is heard in the area, do not operate the machine; seek shelter.
- Use care when loading or unloading the machine into a trailer or truck.
- Use care when approaching blind corners, shrubs, trees, or other objects that may obscure vision.

Maintenance and Storage

- Keep all nuts, bolts and screws tight to be sure the equipment is in safe working condition.
- Never store the equipment with fuel in the tank inside a building where fumes may reach an open flame or spark.
- Allow the engine to cool before storing in any enclosure.
- To reduce the fire hazard, keep the engine, silencer/muffler, battery compartment and fuel storage area free of grass, leaves, or excessive grease.
- Keep all parts in good working condition and all hardware and hydraulic fittings tightened. Replace all worn or damaged parts and decals.
- If the fuel tank has to be drained, do this outdoors.
- Be careful during adjustment of the machine to prevent entrapment of the fingers between moving blades and fixed parts of the machine.
- On multi-cylinder/multi-cutterhead machines, take care as rotating one cylinder/cutterhead can cause other cylinders/cutterheads to rotate.
- Disengage drives, lower the cutting units, set parking brake, stop engine and remove key from ignition. Wait for all movement to stop before adjusting, cleaning or repairing.
- Clean grass and debris from cutting units, drives, silencers/mufflers, and engine to help prevent fires. Clean up oil or fuel spillage.
- Use jack stands to support components when required.
- Carefully release pressure from components with stored energy.
- Disconnect battery before making any repairs. Disconnect the negative terminal first and the positive last. Reconnect positive first and negative last.

- Use care when checking the cylinders/cutterheads. Wear gloves and use caution when servicing them.
- Keep hands and feet away from moving parts. If possible, do not make adjustments with the engine running.
- Charge batteries in an open well ventilated area, away from spark and flames. Unplug charger before connecting or disconnecting from battery. Wear protective clothing and use insulated tools.
- If the engine stalls or loses headway and cannot make it to the top of a slope, do not turn the machine around. Always back slowly, straight down the slope.
- When a person or pet appears unexpectedly in or near the mowing area, stop mowing. Careless operation, combined with terrain angles, ricochets, or improperly positioned guards can lead to thrown object injuries. Do not resume mowing until the area is cleared.

Toro Riding Mower Safety

The following list contains safety information specific to Toro products or other safety information that you must know that is not included in the safety standards.

This product is capable of amputating hands and feet and throwing objects. Always follow all safety instructions to avoid serious injury or death.

Use of this product for purposes other than its intended use could prove dangerous to user and bystanders.

⚠ WARNING

Engine exhaust contains carbon monoxide, which is an odorless, deadly poison that can kill you.

Do not run engine indoors or in an enclosed area.

- Know how to stop the engine quickly.
- Do not operate the machine while wearing tennis shoes or sneakers.
- Wearing safety shoes is advisable and required by some local ordinances and insurance regulations.
- Handle fuel carefully. Wipe up any spills.
- Check the safety interlock switches daily for proper operation. If a switch should fail, replace the switch before operating the machine.
- Before starting the engine, sit on the seat.
- Using the machine demands attention. To prevent loss of control:
 - Do not drive close to sand traps, ditches, creeks, or other hazards.
 - Reduce speed when making sharp turns. Avoid sudden stops and starts.
 - When near or crossing roads, always yield the right-of-way.
 - Apply the service brakes when going downhill to keep forward speed slow and to maintain control of the machine.
- Raise the cutting units when driving from one work area to another.
- Do not touch the engine, silencer/muffler, or exhaust pipe while the engine is running or soon after it has stopped because these areas could be hot enough to cause burns.

Maintenance and Storage

- Make sure all hydraulic line connectors are tight and all hydraulic hoses and lines are in good condition before applying pressure to the system.
- Keep your body and hands away from pin hole leaks or nozzles that eject hydraulic fluid under high pressure. Use paper or cardboard, not your hands, to search for leaks. Hydraulic fluid escaping under pressure can have sufficient force to penetrate the skin and cause serious injury. Seek immediate medical attention if fluid is injected into skin.
- Before disconnecting or performing any work on the hydraulic system, all pressure in the system must be relieved by stopping the engine and lowering the cutting units and attachments to the ground.
- Check all fuel lines for tightness and wear on a regular basis. Tighten or repair them as needed.
- If the engine must be running to perform a maintenance adjustment, keep hands, feet, clothing, and any parts of the body away from the cutting units, attachments, and any moving parts. Keep everyone away.
- To ensure safety and accuracy, have an Authorized Toro Distributor check the maximum engine speed with a tachometer. Maximum governed engine speed should be 3000 RPM.
- If major repairs are ever needed or if assistance is desired, contact an Authorized Toro Distributor.
- Use only Toro-approved attachments and replacement parts. The warranty may be voided if used with unapproved attachments.

Sound Power Level

This unit has a measured sound power level of 100 dB(A), which includes an Uncertainty Value of 1 dB(A).

Sound power level was determined according to the procedures outlined in ISO 11094.

Sound Pressure Level

This unit has a sound pressure level at the operator's ear of 85 dB(A), which includes an Uncertainty Value (K) of 2 dB(A).

Sound pressure level was determined according to the procedures outlined in EN 836.

Safety and Instructional Decals



Safety decals and instructions are easily visible to the operator and are located near any area of potential danger. Replace any decal that is damaged or lost.

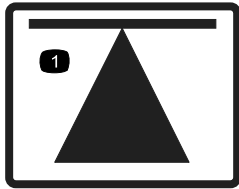

70-13-072

1. Jacking point

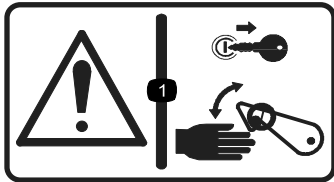

70-13-077

1. Warning—stop the engine and remove the ignition key before releasing or operating safety latches.

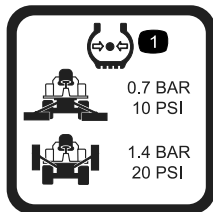

950832

1. Tyre pressure



950889

1. Warning—hot surfaces.

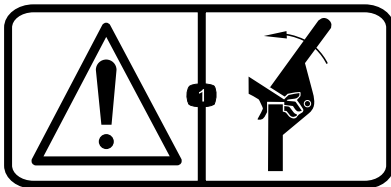

111-0773

1. Warning—crushing of fingers, force applied from side.

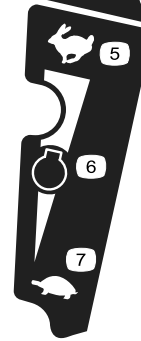
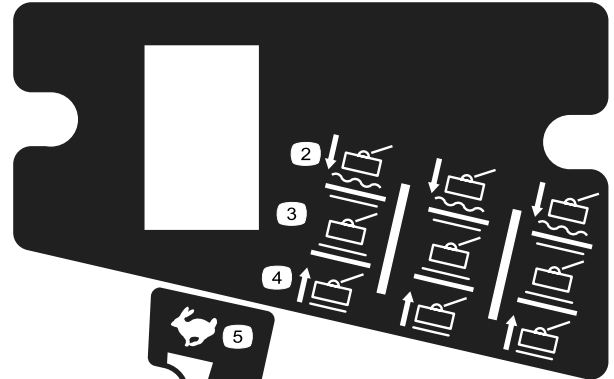

111-3277

- | | |
|------------------------|-----------------|
| 1. Horn | 5. Fast |
| 2. Cutters—lower/float | 6. Engine speed |
| 3. Cutters—hold | 7. Slow |
| 4. Cutters—raise | |

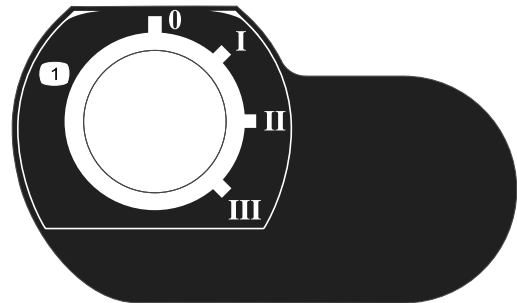

111-3344

1. Ignition switch



111-3562

1. Press pedal to adjust steering wheel tilt.

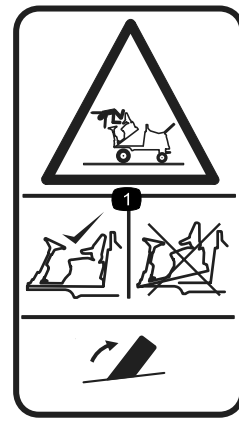

111-3566

1. Falling, crushing hazard—ensure operator platform latch is engaged before operating.

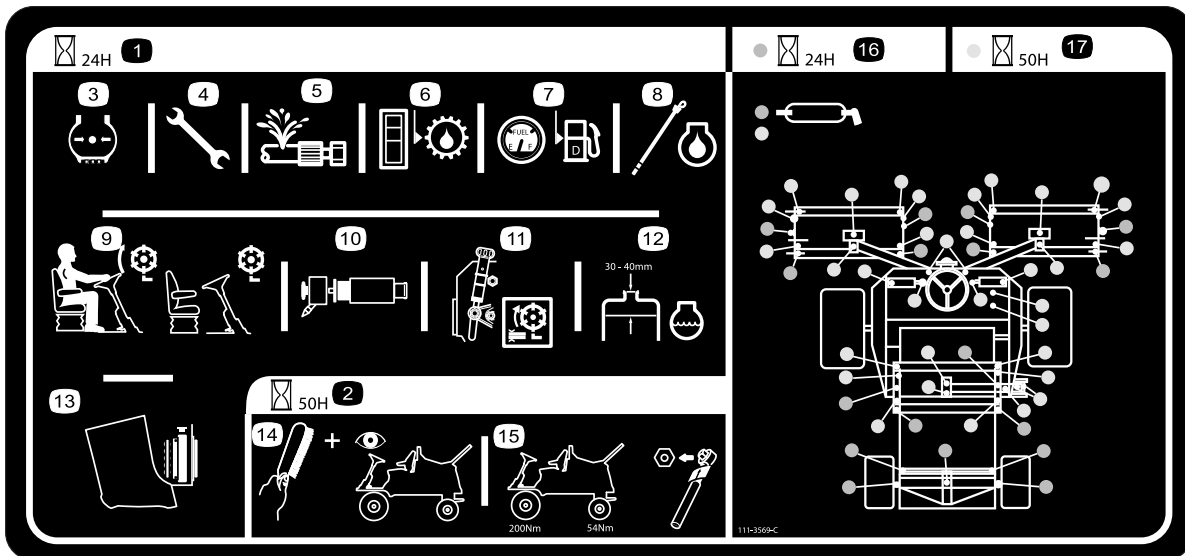

111-3569

- | | | | |
|--|-----------------------------------|---|---|
| 1. 24 hour service interval | 6. Check hydraulic oil level | 11. Check cutter head setting | 16. Lubrication points for 24 hour interval |
| 2. 50 hour service interval | 7. Check fuel level | 12. Check engine coolant level | 17. Lubrication points for 50 hour interval |
| 3. Check the tyre pressure | 8. Check engine oil level | 13. Check cleanliness of radiator | |
| 4. Check all nuts and bolts for proper tightness | 9. Check operation of seat switch | 14. Clean and inspect the machine | |
| 5. Check all hose for leaks | 10. Check air filter element | 15. Check wheel nut tightness using a torque wrench, Front wheels 200 N-m, Rear wheels 54 N-m | |

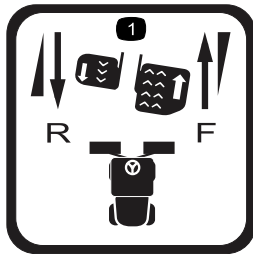

111-3567

1. Pedal operation



111-3902

1. Warning—cutting hazard of hand, fan.
2. Hot surfaces—read the *Operator's Manual* for more information.

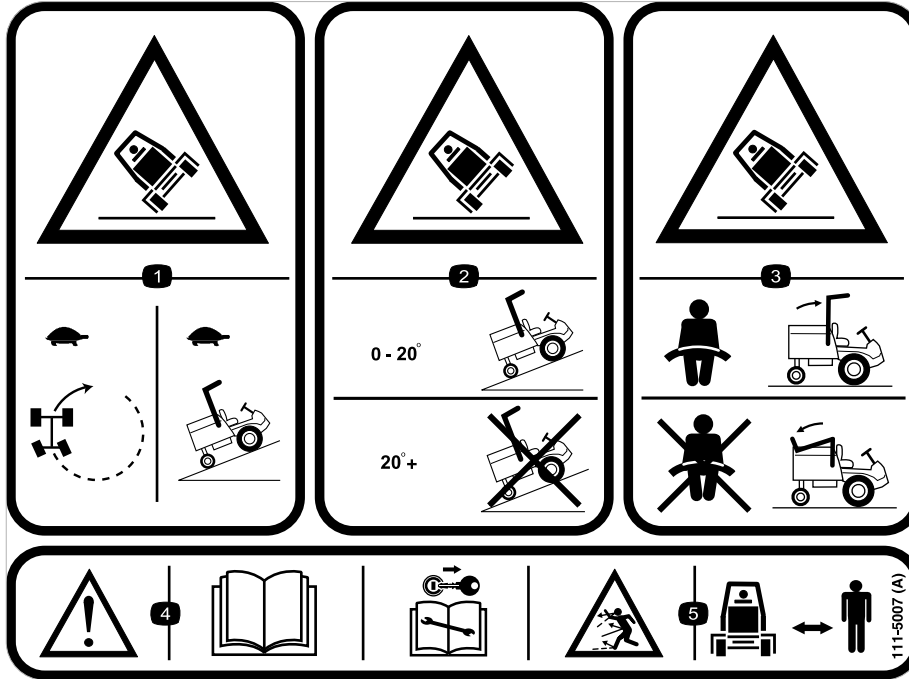

111-5007

1. Tipping hazard—slow machine before turning.
2. Tipping hazard—operate on slopes less than 20 degrees, do not operate on slopes greater than 20 degrees.
3. Tipping hazard—always wear the seat belt when a roll over protection system (ROPS) is in use, do not wear a seat belt when the ROPS bar is lowered.
4. Warning—read the *Operator's Manual*, remove the ignition key before performing any maintenance.
5. Thrown object hazard—keep bystanders a safe distance from the machine.

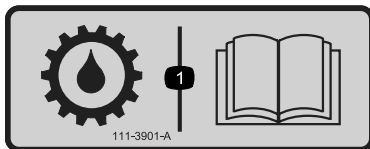

111-3901

1. Transmission oil—read the *Operator's Manual* for more information.

Setup

Media and Additional Parts

Description	Qty.	Use
Operator's Manual	1	Read the Operator's Manual before operating the machine
Engine Operator's Manual	1	Reference engine information
Parts Catalog	1	Reference part numbers
CE certificate	1	Declaration of Certification

Store all documentation in a safe place for future use.

Note: Determine the left and right sides of the machine from the normal operating position.

Checking the Tyre Pressure

Correct air pressure in the front and rear tyres. See the chart below for the correct pressure.

Important: Maintain correct tyre pressures in all tyres to ensure correct contact with the turf.

Tyres	Tyre Type	Recommended Tyre Pressures		
		Turf Conditions	Road Conditions	Max Pressure
Front Axle	26 x 12.00 - 12 BKT turf pattern	0.7 bar (10 psi)	1.4 bar (20 psi)	1.7 bar (25 psi)
Rear Axle	20 x 10.00 - 8 BKT turf pattern	0.7 bar (10 psi)	1.4 bar (20 psi)	1.7 bar (25 psi)

Product Overview

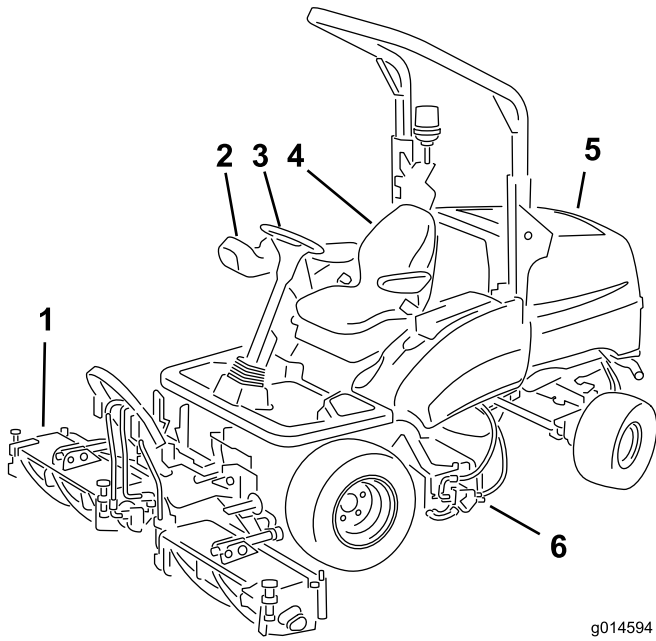

Figure 2

- | | |
|------------------------|----------------------|
| 1. Front cutting units | 4. Operator's seat |
| 2. Control arm | 5. Engine hood |
| 3. Steering wheel | 6. Rear cutting unit |

g014594

Controls

Control Panel Components

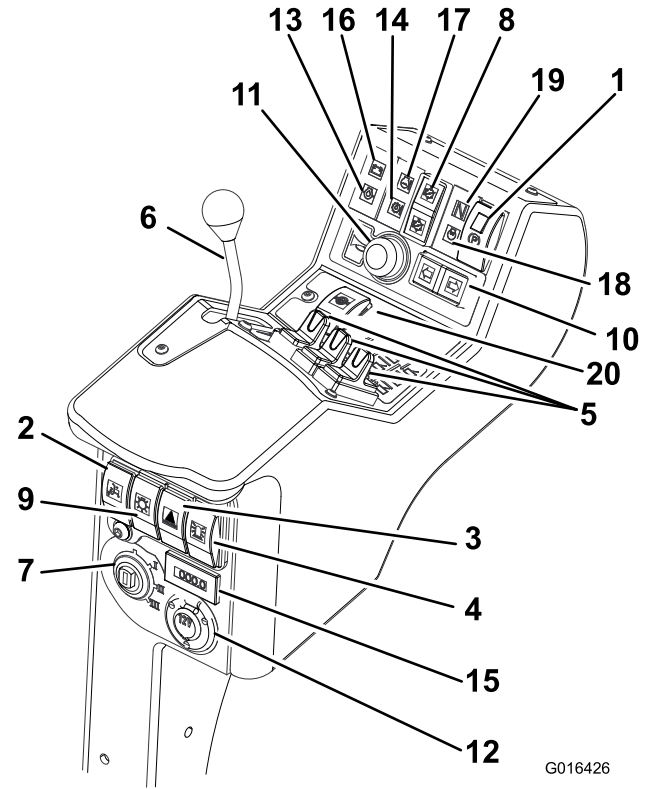

Figure 3

- | | |
|---|--|
| 1. Parking brake switch | 11. Horn button |
| 2. Limited lift in reverse switch | 12. Auxiliary 12 volt socket (supplied with a 12V kit) |
| 3. Hazard warning switch (supplied with lighting kit) | 13. Engine oil pressure indicator |
| 4. Warning beacon switch (supplied with beacon kit) | 14. Transmission temperature indicator |
| 5. Cutterheads position controls | 15. Hour meter |
| 6. Throttle control lever | 16. Battery warning indicator |
| 7. Ignition switch | 17. Engine temperature warning indicator |
| 8. Cutterheads drive switch | 18. Glow plug indicator |
| 9. Lighting switch (supplied with lighting kit) | 19. Transmission neutral indicator |
| 10. Direction indicator switch (supplied with lighting kit) | 20. Differential lock switch |

G016426

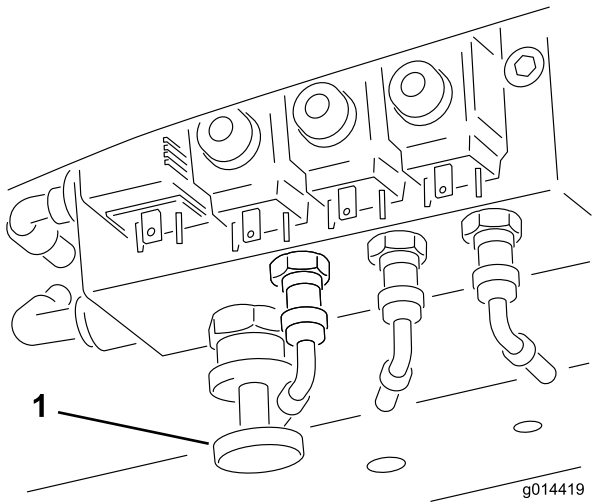

Figure 4

1. Weight transfer control

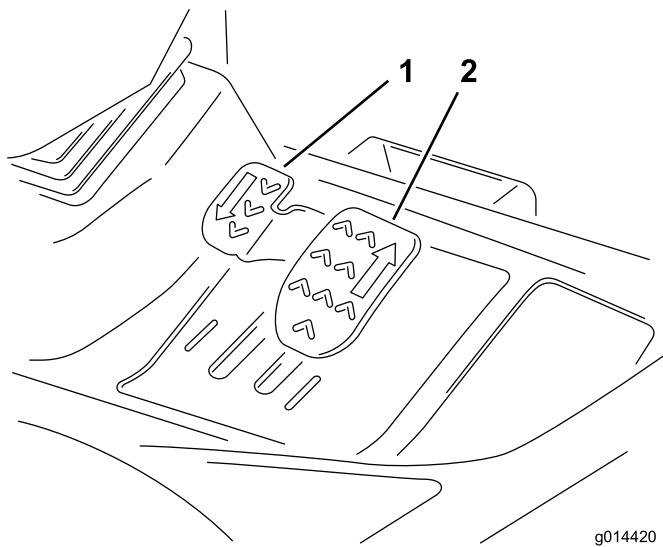

Figure 5

1. Reverse travel pedal
2. Forward travel pedal

Braking System

Parking Brake

Move the parking brake switch to its forward position by depressing the smaller locking button and moving the switch forward to engage the parking brake (Figure 6).

Note: Do not operate the mower with the parking brake engaged and do not engage the parking brake while the mower is moving.

This light illuminates when the parking brake is engaged and the ignition key is turned to position **I**.

▲ WARNING

The parking brake operates on the front wheels only. Do not park the mower on a slope.

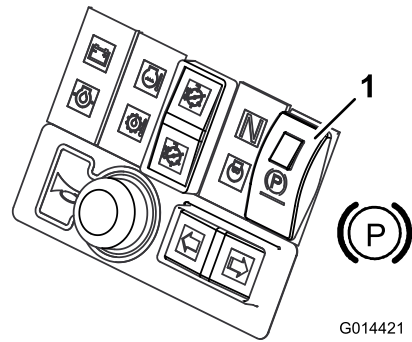

Figure 6

1. Parking brake

Service Brake

Service braking is achieved by the hydraulic transmission system. When the forward or reverse travel pedals are released or the engine speed reduced, service braking becomes effective and travel speed is automatically reduced. To increase the braking effect, push the transmission pedal into the neutral position. Service braking is effective on the front wheels only.

▲ WARNING

The service braking system will not hold the mower at a standstill. **ALWAYS** ensure the parking brake is engaged to park the mower at a standstill.

Emergency Brake

In the event of service brake failure, turn the ignition off to bring the mower to a stand still.

▲ WARNING

Take care when using the emergency braking. Remain seated and hold on to the steering wheel to prevent ejection from the mower caused by the front wheel brakes being applied suddenly when travelling.

Throttle Control

Operate the throttle control in a forward direction to increase the engine speed. Operate the throttle control in a rearward direction to reduce engine speed (Figure 7).

Note: The engine speed dictates the speed of the other functions, i.e. travel, cutting cylinder rotation speed and cutterhead lift speed.

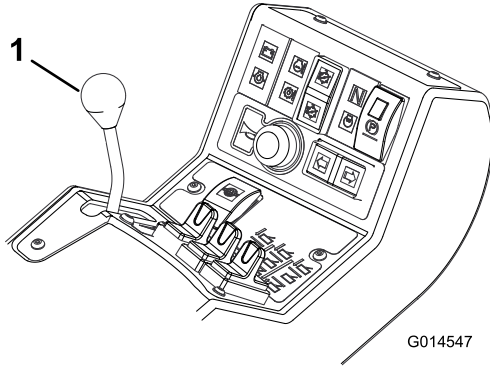
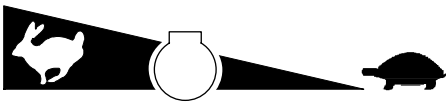

Figure 7

1. Throttle control lever

Travel

Forward travel: Depress the forward travel pedal to increase forward travel speed. Release the pedal to reduce speed (Figure 8).

Reverse travel: Depress the reverse travel pedal to increase reverse travel speed. Release the pedal to reduce speed (Figure 8).

Stop (Neutral): Release the forward or reverse travel pedal.

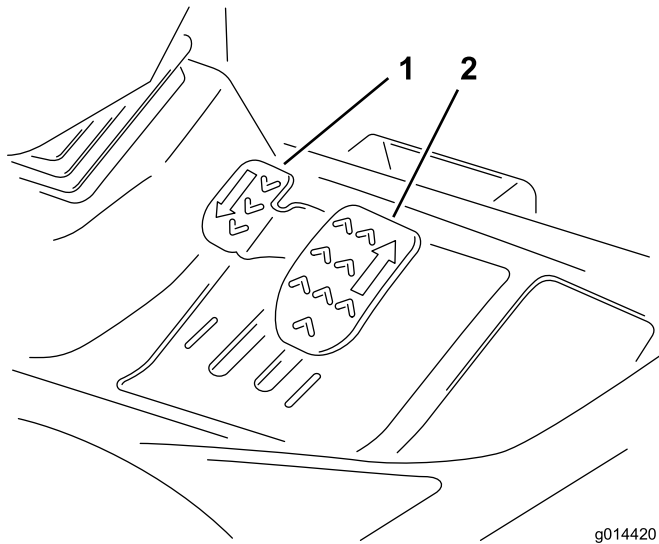

Figure 8

1. Reverse travel pedal
2. Forward travel pedal

Transport Latches

Always raise the cutterheads to the transport position and secure with the transport latches and safety locks when travelling between work areas (Figure 9).

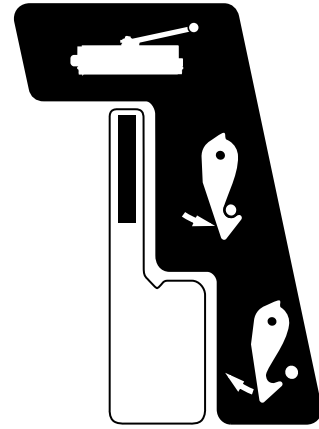

Figure 9

G014548

Cutterhead Drive Switch

Always put the cutterhead drive switch in the **Off** position when travelling between work areas.

Adjustable Steering Column

⚠ WARNING

Never operate the mower without first checking that the steering column adjuster mechanism is in good working order and that, once adjusted and locked, the steering wheel remains securely in position.

Adjustment of the steering wheel and steering column should only be carried out when the mower is at a standstill with the parking brake engaged.

1. To tilt the steering wheel, press the foot pedal down.
2. Position the steering tower to the most comfortable position and release the pedal (Figure 10).



G014549

Figure 10

Operator Seat

⚠ WARNING

Never operate the mower without first checking that the operator seat mechanisms are in good working order and that, once adjusted and locked, the seat remains securely in position.

Adjustment of the seat mechanisms should only be carried out when the mower is at a standstill with the parking brake engaged.

- **Fore/Aft Adjustment:** Move the lever upwards to adjust the fore/aft position of the seat. Release the lever to lock the seat in position (Figure 11).

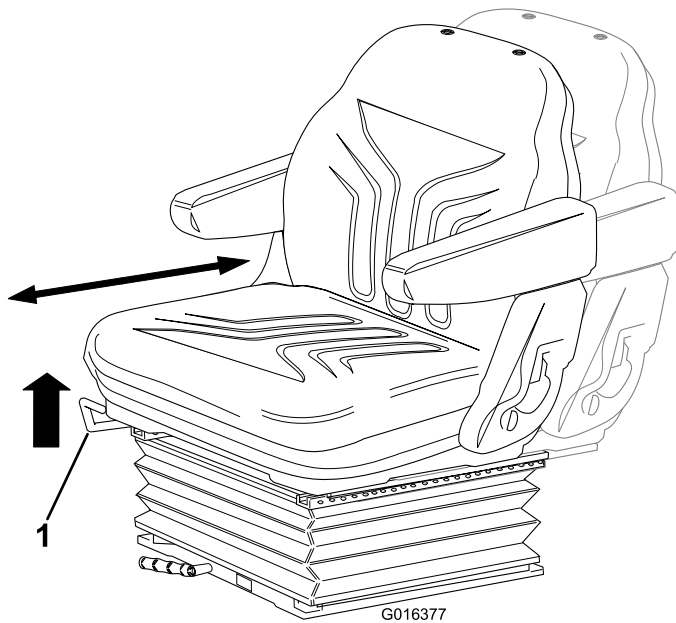

G016377

Figure 11

1. Lever

- **Operator weight adjustment:** Rotate the handle clockwise to increase suspension stiffness and counter-clockwise to decrease. The dial indicates when the optimum suspension adjustment has been set according to operator weight (kg) (Figure 12).

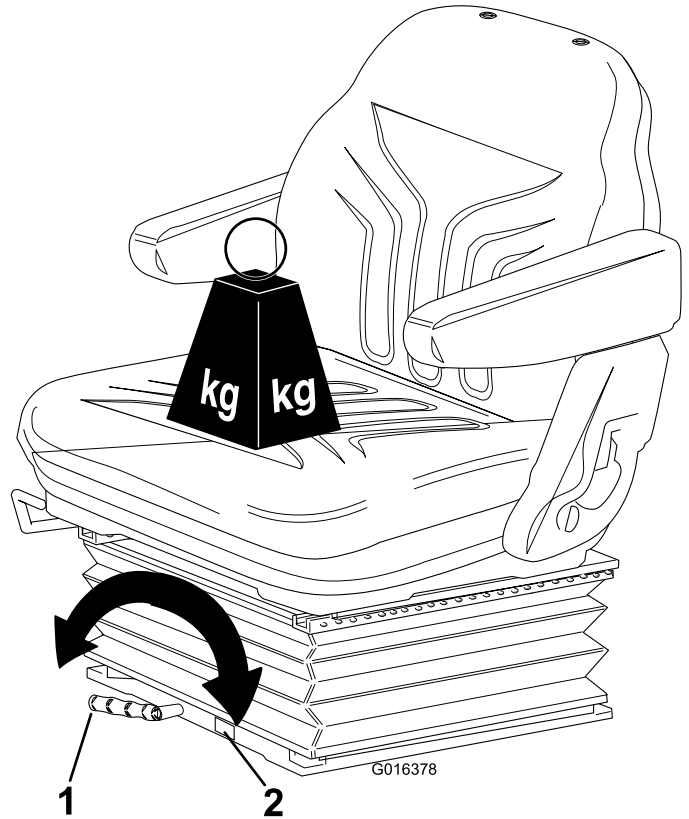

G016378

Figure 12

1. Lever

2. Dial

- **Height adjustment:** Manually lift the seat for incremental height adjustment. To lower, lift the seat beyond its highest setting, then allow it to drop to the lowest setting (Figure 13).

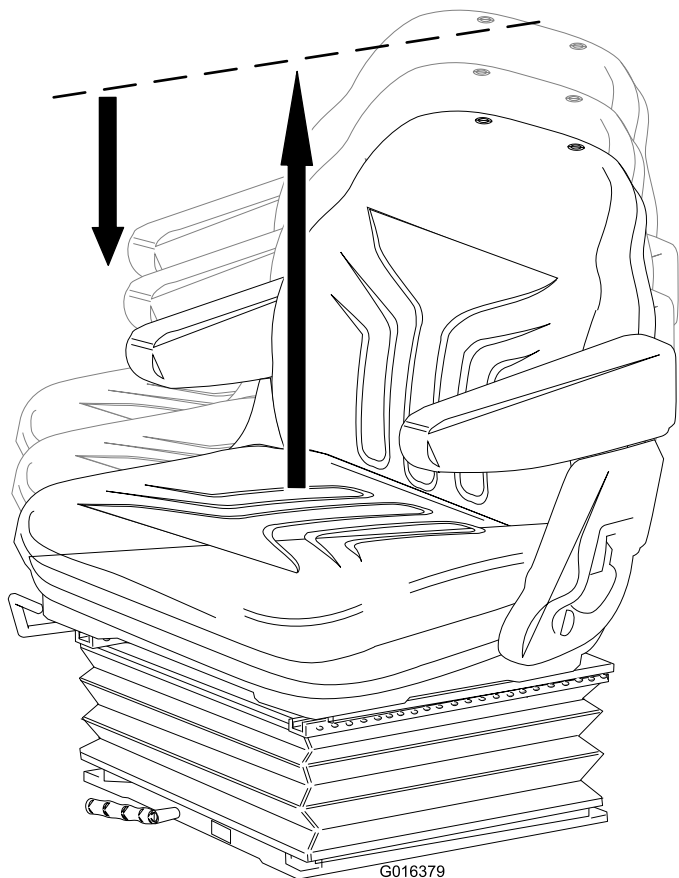

G016379
Figure 13

- **Backrest adjustment:** Pull the handle outwards to adjust the seat backrest angle. Release the handle to lock the seat backrest in position.

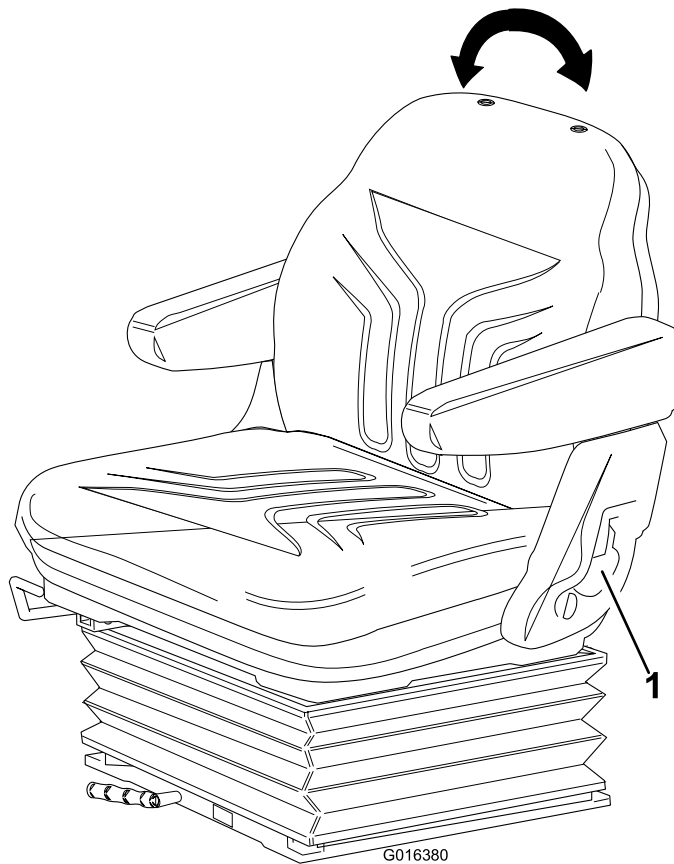

G016380
Figure 14

1. Handle

Warning Systems

Engine Coolant Overheating Warning Light

The engine coolant warning light illuminates, the horn is actuated and the cutters stop (Figure 15).

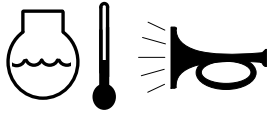
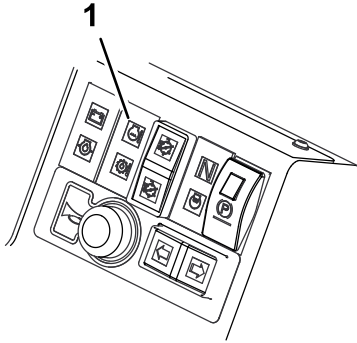

G014551

Figure 15

1. Engine coolant overheating warning light

Hydraulic Oil Overheating Warning Light

The hydraulic oil warning light illuminates when overheating occurs and the horn is actuated when the hydraulic oil in the reservoir exceeds 95 degrees C (203 degrees F) (Figure 16).

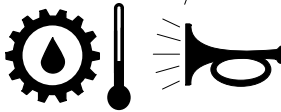
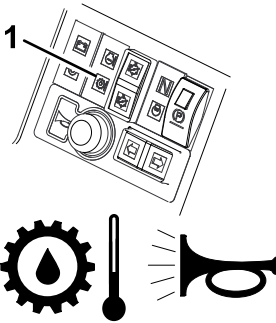

G014552

Figure 16

1. Hydraulic oil overheating warning light

Low Battery Charge Warning Light

The battery charge warning light illuminates when low battery charge occurs (Figure 17).

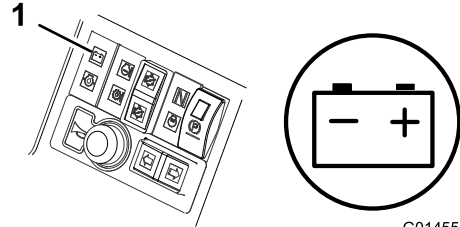

G014553

Figure 17

1. Low battery charge warning light

Low Engine Oil Pressure Warning Light

The engine oil pressure warning light illuminates when the oil pressure is too low (Figure 18).

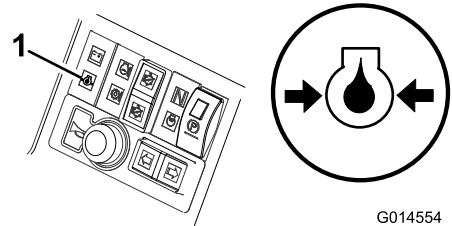

G014554

Figure 18

1. Low engine oil pressure warning light

Disengagement of Cutting Cylinders

The cutting cylinders will disengage when the operating temperature reaches 115 degrees C.

Audible Warning Horn

Depress the horn button to provide an audible warning (Figure 19).

Important: The horn is automatically actuated when an engine coolant or hydraulic oil overheat condition occurs. **STOP** the engine immediately and fix the machine before restarting.

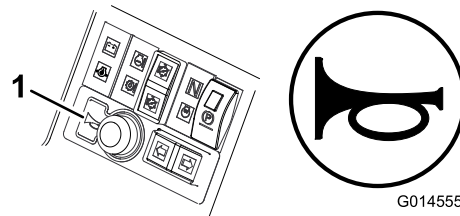

G014555

Figure 19

1. Horn

Ignition Key

0 = Engine off.
I = Engine run/Auxiliary on.
II = Engine pre-heat.
III = Engine start.

⚠ WARNING

Always remove the ignition key when the mower is not in use.

Important: Always install the protective cap when the ignition key is removed to prevent ingress of dirt and moisture damaging the mechanism.

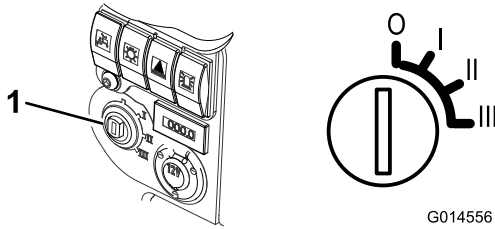

Figure 20

1. Ignition switch

Engine Pre-Heat Indicator Light

Turn the ignition key to position **II**. The engine preheat indicator light will illuminate and heat the glow plugs (Figure 21).

Important: Attempting to start a cold engine before the pre-heat is used can cause unnecessary wear to the battery.

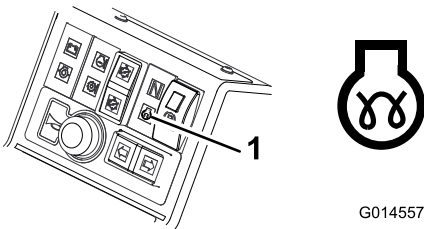
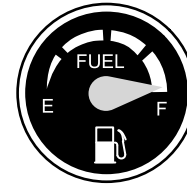

Figure 21

1. Engine pre-heat indicator light

Fuel Gauge

The fuel gauge shows the amount of fuel in the tank (Figure 22).



G014558

Figure 22

Hour Meter

The hour meter shows the total hours that the machine has been operated (Figure 23).

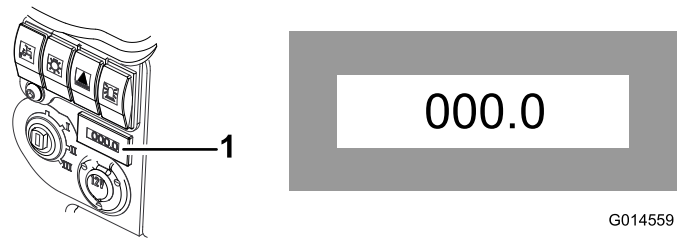

G014559

Figure 23

1. Hour meter

Transmission Neutral Indicator Light

This light illuminates when the travel control pedal is in the neutral position and the ignition key is turned to position **I** (Figure 24).

Note: The parking brake must be engaged for the transmission neutral indicator light to illuminate.

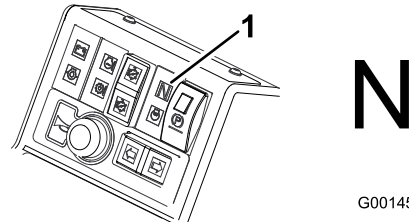

G0014560

Figure 24

1. Transmission neutral indicator light

Cutterhead Drive Switch Indicator Light

This light illuminates when the cutterhead drive switch is in the forward/reverse position and the ignition key is turned to position I (Figure 25).

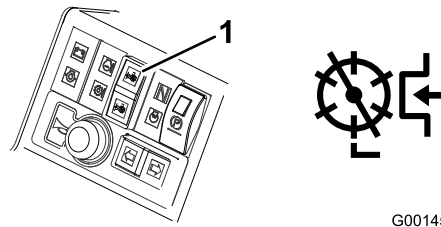

G0014561

Figure 25

1. Cutterhead Drive Switch Indicator Light

Specifications

Note: Specifications and design are subject to change without notice.

Specification	LT 3340
Transport Width	1575 mm (62 inches)
Width of cut	2120 mm (83.5 inches)
Length	2860 mm (112.6 inches)
Height	1681 mm (66.2 inches) with R.O.P.S. folded 2360 mm (92.9 inches) with R.O.P.S. in its vertical operating position
Weight	1325 kg (2921 lbs)* With fluids and 250mm 6 blade cutterheads
Engine	Kubota 26.5 kw (35.5 hp) at 3000 rpm DIN 70020
Fuel tank capacity	45 litres (10 UK gallons)
Transport speed	25 km/h (15.5 mph)
Mowing speed	11 km/h (6.85 mph)
Hydraulic system capacity	32 litres (7.04 UK Gallons)

Attachments/Accessories

A selection of Toro approved attachments and accessories are available for use with the machine to enhance and expand its capabilities. Contact your Authorized Service Dealer or Distributor.

Operation

Note: Determine the left and right sides of the machine from the normal operating position.

⚠ CAUTION

If you leave the key in the ignition switch, someone could accidentally start the engine and seriously injure you or other bystanders.

Lower the cutting units to the ground, set the parking brake and remove the key from the ignition switch before servicing or making adjustments to the machine.

Checking the Engine Oil Level

Service Interval: Before each use or daily

The engine is shipped with oil in the crankcase; however, the oil level must be checked before and after the engine is first started.

Crankcase capacity is approximately 6 litres (203 ounces) with the filter.

Use high-quality engine oil that meets the following specifications:

- API Classification Level Required: CH-4, CI-4 or higher
- Preferred oil: SAE 15W-40 (above 0 degrees F)
- Alternate oil: SAE 10W-30 or 5W-30 (all temperatures)

Toro Premium Engine oil is available from your distributor in either 15W-40 or 10W-30 viscosity.

Note: The best time to check the engine oil is when the engine is cool before it has been started for the day. If it has already been run, allow the oil to drain back down to the sump for at least 10 minutes before checking. If the oil level is at or below the **add** mark on the dipstick, add oil to bring the oil level to the **full** mark. **DO NOT OVERFILL.** If the oil level is between the **full** and **add** marks, no oil addition is required.

1. Park the machine on a level surface, stop the engine, set the parking brake and remove the key from the ignition switch.
2. Open the hood.
3. Remove the dipstick, wipe it clean, and install it (Figure 26).

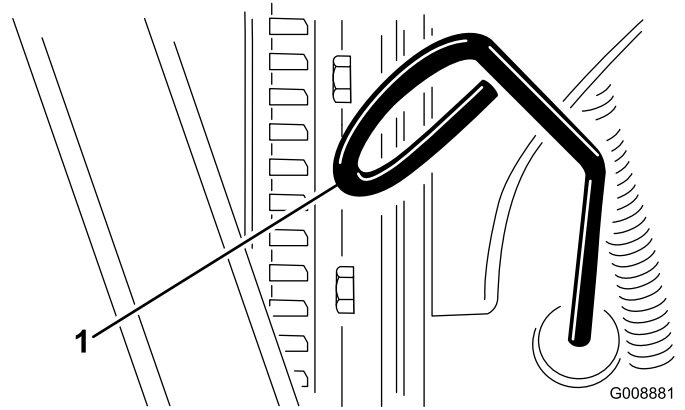

Figure 26

1. Dipstick

4. Remove dipstick and check oil level on dipstick.
The oil level should be up to the Full mark .
5. If the oil level is below the Full mark, remove the fill cap (Figure 27) and add oil until level reaches the Full mark on dipstick. **Do not overfill.**

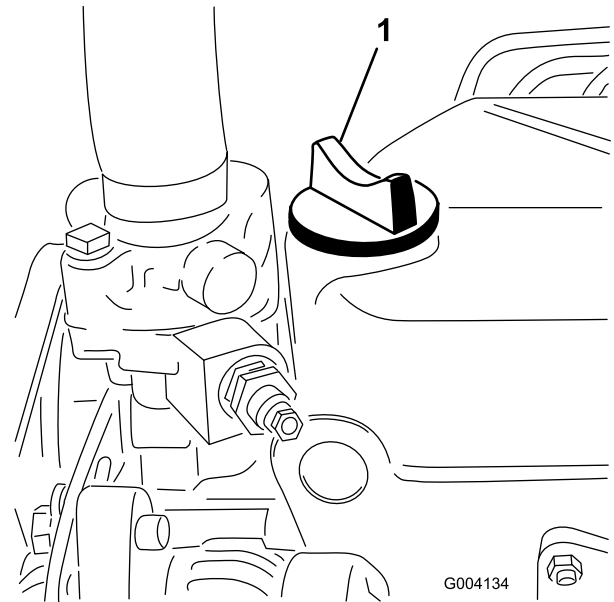

Figure 27

1. Oil fill cap

6. Install the oil fill cap and close the hood.

Checking the Cooling System

Service Interval: Before each use or daily

⚠ CAUTION

If the engine has been running, the pressurized, hot coolant can escape and cause burns.

- Allow the engine to cool down before opening the radiator cap.
- Do not open the radiator cap when the engine is running.
- Use a rag when opening the radiator cap, and open the cap slowly to allow steam to escape.

The cooling system is filled with a 50/50 solution of water and permanent ethylene glycol antifreeze.

1. Clean debris off of the screen, oil cooler, and front of the radiator daily and more often if conditions are extremely dusty and dirty. Refer to the section on Removing Debris from the Cooling System in Maintenance.
2. Remove the cap from the radiator.
3. The coolant level needs to be 30mm - 40mm (1.2-1.6 inches) below the top of the filler neck.

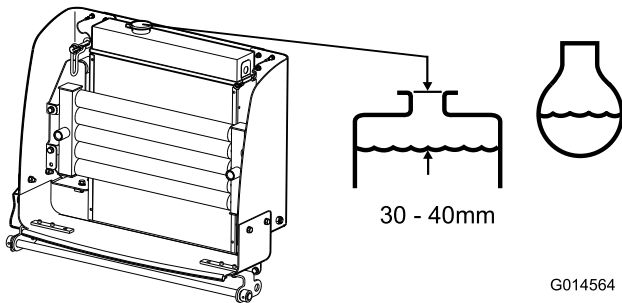

Figure 28

Adding Fuel

Service Interval: Before each use or daily

Use only clean, fresh diesel fuel with low (<50 ppm) or ultra low (<15 ppm) sulfur content. The minimum cetane rating should be 40. Purchase fuel in quantities that can be used within 180 days to ensure fuel freshness.

Fuel tank capacity: 45 litres (10 UK gallons)

Use summer grade diesel fuel (No. 2-D) at temperatures above -7° C (20° F) and winter grade (No. 1-D or No. 1-D/2-D blend) below that temperature. Use of winter grade fuel at lower temperatures provides lower flash point and cold flow characteristics which will ease starting and reduce fuel filter plugging.

Use of summer grade fuel above -7° C (20° F) will contribute toward longer fuel pump life and increased power compared to winter grade fuel.

Important: Do not use kerosene or gasoline instead of diesel fuel. Failure to observe this caution will damage the engine.

⚠ WARNING

Fuel is harmful or fatal if swallowed. Long-term exposure to vapors can cause serious injury and illness.

- Avoid prolonged breathing of vapors.
- Keep face away from nozzle and fuel tank or conditioner opening.
- Keep fuel away from eyes and skin.

⚠ DANGER

In certain conditions, fuel is extremely flammable and highly explosive. A fire or explosion from fuel can burn you and others and can damage property.

- Fill the fuel tank outdoors, in an open area, when the engine is cold. Wipe up any fuel that spills.
- Never fill the fuel tank inside an enclosed trailer.
- Never smoke when handling fuel, and stay away from an open flame or where fuel fumes may be ignited by a spark.
- Store fuel in an approved container and keep it out of the reach of children. Never buy more than a 180-day supply of fuel.
- Do not operate machine without entire exhaust system in place and in proper working condition.

▲ DANGER

In certain conditions during fueling, static electricity can be released causing a spark which can ignite the fuel vapors. A fire or explosion from fuel can burn you and others and can damage property.

- Always place fuel containers on the ground away from your vehicle before filling.
- Do not fill fuel containers inside a vehicle or on a truck or trailer bed because interior carpets or plastic truck bed liners may insulate the container and slow the loss of any static charge.
- When practical, remove equipment from the truck or trailer and refuel the equipment with its wheels on the ground.
- If this is not possible, then refuel such equipment on a truck or trailer from a portable container, rather than from a fuel dispenser nozzle.
- If a fuel dispenser nozzle must be used, keep the nozzle in contact with the rim of the fuel tank or container opening at all times until fueling is complete.

1. Park the machine on a level surface.
2. Using a clean rag, clean the area around the fuel tank cap.
3. Remove the cap from the fuel tank.
4. Fill the tank until the level is to the bottom of the filler neck with diesel fuel.
5. Install the fuel tank cap tightly after filling the tank.

Note: If possible, fill the fuel tank after each use. This will minimize possible buildup of condensation inside the fuel tank.

Checking the Hydraulic Fluid

The machine's reservoir is filled at the factory with approximately 32 l (7.04 UK gallons) of high quality hydraulic fluid. Check the level of the hydraulic fluid before the engine is first started and daily thereafter. The recommended replacement fluid is as follows:

Toro Premium All Season Hydraulic Fluid (Available in 5 gallon pails or 55 gallon drums. See parts catalog or Toro distributor for part numbers.)

Alternate fluids: If the Toro fluid is not available, other fluids may be used provided they meet all the following material properties and industry specifications. We do not recommend the use of synthetic fluid. Consult with your lubricant distributor to identify a satisfactory product. Note: Toro will not assume responsibility for damage caused by

improper substitutions, so use only products from reputable manufacturers who will stand behind their recommendation.

High Viscosity Index/Low Pour Point Anti-wear Hydraulic Fluid, ISO VG 46

Material Properties:

Viscosity, ASTM D445 cSt @ 40°C 44 to 48
cSt @ 100°C 7.9 to 8.5

Viscosity Index ASTM D2270 140 to 160

Pour Point, ASTM D97 -34°F to -49°F

Industry Specifications:

Vickers I-286-S (Quality Level), Vickers M-2950-S (Quality Level), Denison HF-0

Note: Many hydraulic fluids are almost colorless, making it difficult to spot leaks. A red dye additive for the hydraulic system oil is available in 2/3 oz. (20 ml) bottles. One bottle is sufficient for 15-22 l (4-6 gal) of hydraulic oil. Order part no. 44-2500 from your authorized Toro distributor.

Biodegradable Hydraulic Fluid - Mobil 224H

Toro Biodegradable Hydraulic Fluid (Available in 5 gallon pails or 55 gallon drums. See parts catalog or Toro distributor for part numbers.)

Alternate fluid: Mobil EAL 224H

Note: This is vegetable-oil based biodegradable oil tested and approved by Toro for this model. This fluid is not as resistant to high temperatures as standard fluid, so be sure to follow the recommended fluid change intervals with this fluid. Contamination by mineral-based hydraulic fluids will change the biodegradability and toxicity of this oil. When changing from standard fluid to the biodegradable type, be certain to follow the approved flushing procedure. Contact your local Toro Distributor for details.

1. Position machine on a level surface, lower the cutting units and stop the engine.
2. Check the sight level gauge on the side of the tank. The level needs to be at the upper mark.
3. If hydraulic oil is needed, clean area around the cap of hydraulic tank (Figure 29). Remove cap from the tank.

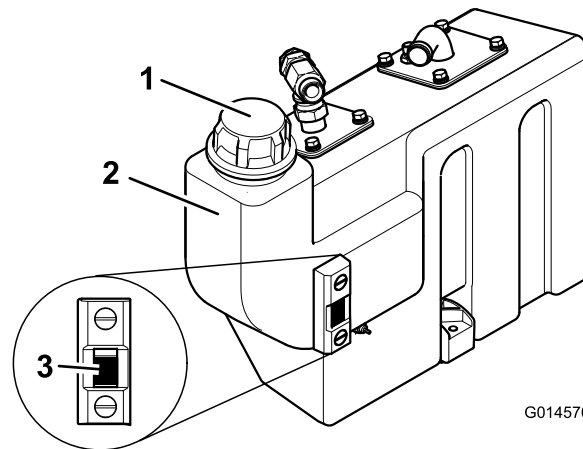

Figure 29

1. Hydraulic tank cap
2. Oil tank
3. Sight level gauge

- Remove the cap and fill the tank to the upper mark on the sight level gauge. Do not overfill.
- Install the cap onto the tank.

Check the Torque of the Wheel Nuts

Service Interval: Before each use or daily

Torque the wheel nuts to 200 N-m (148 ft-lb) for the front axle, and 54 N-m (40 ft-lb) for the rear axle.

⚠ WARNING

Failure to maintain proper torque of the wheel nuts could result in personal injury.

Operator Platform Latching Mechanism

Do not operate the mower without first checking that the operator platform latching mechanism is fully engaged and in good working order.

⚠ WARNING

Never operate the mower without first checking that the operator platform latching mechanism is fully engaged and in good working order.

Releasing the Platform

- Move the locking latch handle towards the front of the mower until the latch hooks clear the locking bar.
- Raise the platform. The gas spring will provide assistance.

Securing the Platform

- Lower the platform carefully. The gas spring will provide assistance.
- Move the locking latch handle towards the front of the mower as the platform nears the fully lowered position. This will ensure that the latch hooks clear the locking bar.
- Fully lower the platform and move the locking handle towards the rear of the mower until the latch hooks fully engage the locking bar.

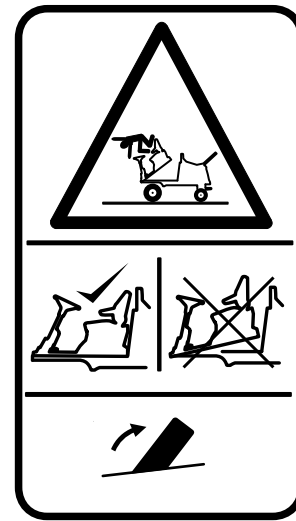

G014422

Figure 30

Operator Presence Control

Note: The engine will cut out if the operator leaves the seat without engaging the parking brake.

Engine Start Lockout: The engine can only be started when the forward/reverse travel pedal is in the **NEUTRAL** position, the cutterhead drive switch is in the **OFF** position and the parking brake is engaged. When these circumstances are satisfied, switches are activated permitting the engine to be started.

Engine Run Interlock: Once the engine is started the operator must be seated before the parking brake is released for the engine to continue to run.

Cutting Cylinder Drive Lockout: The drive to the cutting cylinders is only possible when the operator is seated. If the operator raises off the seat for a period of more than one second, a switch is activated and the drive to the cutting cylinders is automatically disengaged. To engage drive to the cutting cylinders, the operator must return to the seat, then operate the cutterhead drive switch to the **OFF** position before moving it back to the **ON** position. If the operator rises off the seat for a brief moment during normal work, drive to the cutting cylinders is not affected.

The engine can only be started with the cutterhead drive switch in the **OFF** position.

⚠ WARNING

Do not operate the turf mower if the operator presence controls are defective in any way. *Always* replace faulty parts and check that they function correctly before operating the mower.

⚠ CAUTION

If safety interlock switches are disconnected or damaged the machine could operate unexpectedly causing personal injury.

- Do not tamper with the interlock switches.
- Check the operation of the interlock switches daily and replace any damaged switches before operating the machine.

Starting and Stopping the Engine

Important: You must bleed the fuel system before starting the engine if you are starting the engine for the first time, the engine has stopped due to lack of fuel, or you have performed maintenance on the fuel system; refer to Bleeding the Fuel System.

⚠ WARNING

Before starting the engine check that:

- You have read and understood the Safety Precautions section in this manual.
- The area is clear of bystanders.
- The cutterhead drive is disengaged.
- The parking brake is engaged.
- The travel control pedals are in neutral.

Important: This machine is fitted with an Engine start lockout, refer to OPERATOR PRESENCE CONTROLS.

Starting a Cold Engine

1. Sit on the seat, keep your foot off of the traction pedals so that it is in Neutral, engage the parking brake and set the throttle to the 70 percent full throttle position.
2. Turn the ignition key to the ignition on position **I** and check that the engine oil pressure and battery charge warning lights illuminate.
3. Turn the ignition key to the preheat position **II** so that the pre-heat indicator light is on. Hold it for 5 seconds to heat the glow plugs.
4. After preheating the glow plugs, turn key to the start position **III** and hold to crank the engine.
Crank the engine for no longer than 15 seconds. Release the ignition key back to position **I** when the engine starts.
5. Run the engine at low idle speed until it warms up.

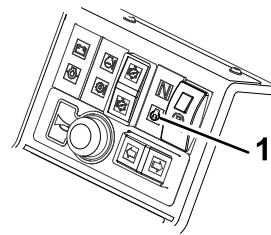

G014557

Figure 31

1. Engine pre-heat indicator light

⚠ WARNING

When the engine is operating all warning lights should be off. If a warning light illuminates, stop the engine immediately and have the fault rectified before restarting.

Starting a Warm Engine

1. Sit on the seat, keep your foot off of the traction pedal so that it is in Neutral, engage the parking brake and set the throttle to the 70 percent full throttle.
2. Turn the ignition key to the ignition on position **I** and check that the engine oil pressure and battery charge warning lights illuminate.
3. Turn the ignition key to the start position **III** and hold to crank the engine.
Crank the engine for no longer than 15 seconds. Release the ignition key back to position **I** when the engine starts.
4. Run the engine at low idle speed until it warms up.

Stopping the Engine

1. Move all controls to Neutral, set the parking brake, move the throttle to the low idle position and allow the engine to reach low idle speed.
2. Let the engine idle for 5 minutes.
3. Turn the ignition key to position **0**.

Important: Allow the engine to idle for 5 minutes before shutting it off after a full load operation. Failure to do so may lead to trouble on a turbo-charged engine.

If the engine fails to stop when the ignition key is turned to **0**, operate the engine stop lever in forward direction (Figure 32).

⚠ WARNING

Keep hands clear of moving objects and hot engine parts while the engine is running.

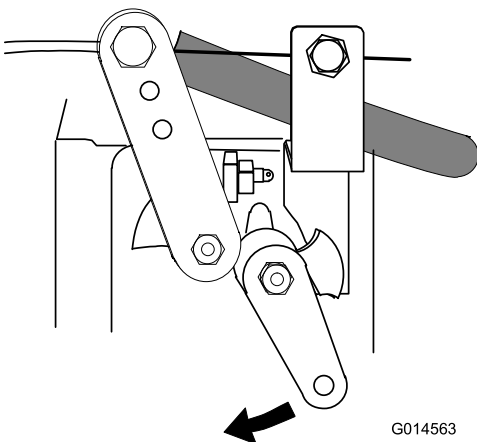

Figure 32

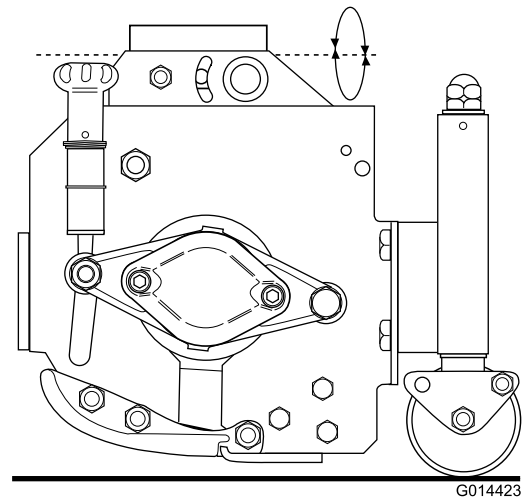

Figure 33

Checking the Cylinder to Bedknife Contact

Each day before operating, check the cutterhead to bedknife contact, regardless if the quality of cut had previously been acceptable. There must be light contact across the full length of the cutterhead and the bedknife.

Cutterheads General Information

This machine is designed to be used with MK3 8 inch (20 cm) fixed or floating cutterheads and 10 inch (25 cm) fixed cutterheads.

It is essential that the relationship between the bottom blades and the cutting cylinders are kept in good adjustment and that cutting edges are kept sharp to ensure good cutting performance, minimum power consumption and prolonged life for the cutting edges, refer to Cutterheads Maintenance (page 46).

MK3 Fixed cutterhead 8 inch (20 cm) and Fixed cutterhead 10 inch (25 cm): When the mower is set up with fixed cutterheads the height of cut is gauged by the rear roller and the cutterhead is allowed to pivot laterally to follow ground contours. This arrangement is recommended for general mowing requirements (Figure 33).

MK3 Floating cutterhead 8 inch (20 cm): When the mower is set up with floating cutterheads the height of cut is gauged by the front and rear rollers. The cutterhead is allowed to pivot fore and aft as well as laterally. This arrangement is recommended for high quality grass areas and performs well where grass is short and the ground undulations are severe (Figure 34).

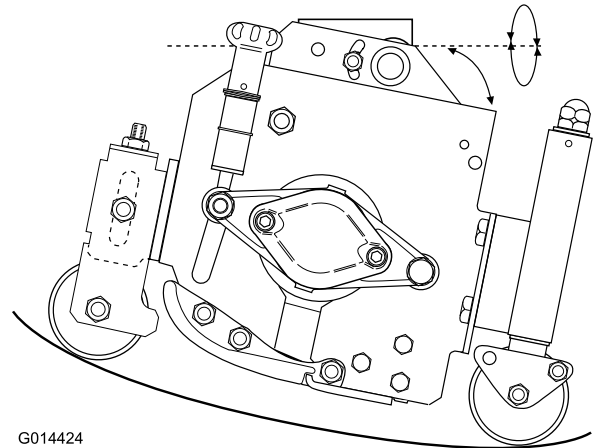

Figure 34

Grass deflectors: The rear grass deflectors must always be correctly fitted. The deflectors should be set as low as possible to deflect grass discharge to the ground (Figure 35).

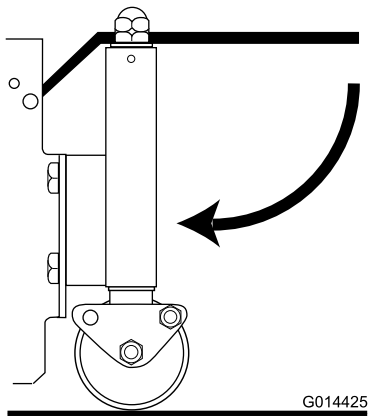

Figure 35

MK3 Fixed cutterhead 8 inch (20 cm) and Fixed cutterhead 10 inch (25 cm)

Pivot knuckle fixing: Secure the bolt in the front fixed hole position in Figure 37 as shown.

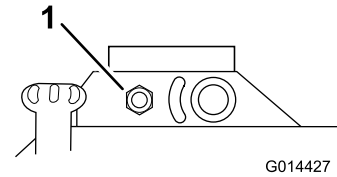

Figure 37

1. Front fixed hole position

⚠ WARNING

Always ensure that the grass deflectors are angled below horizontal level, otherwise risks to health and safety may result.

Height of cut gauge: An optional height of cut gauge is available to assist in achieving accurate cut height settings. It is suitable for both fixed and floating cutterheads (Figure 36).

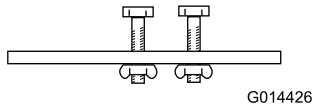

Figure 36

Height of cut adjustment: The height of cut is gauged by the position of the rear roller. Turn the adjusting nut assembly both ends clockwise to decrease height of cut or anti-clockwise to increase height of cut (Figure 38).

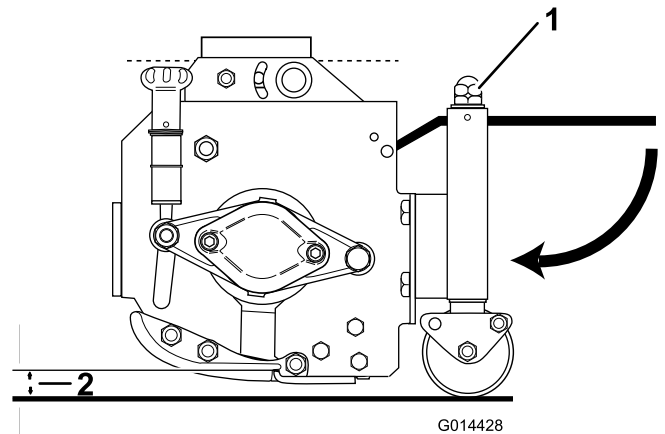

Figure 38

1. Adjusting nut assembly
2. Height of cut

Important: Do not attempt to unlock the nut assemblies.

Ensure that all cutterheads are set at the same height of cut by either referring to the indicator rings (Figure 39) or by using a height of cut gauge across the full width of each cutterhead for greater accuracy as shown.

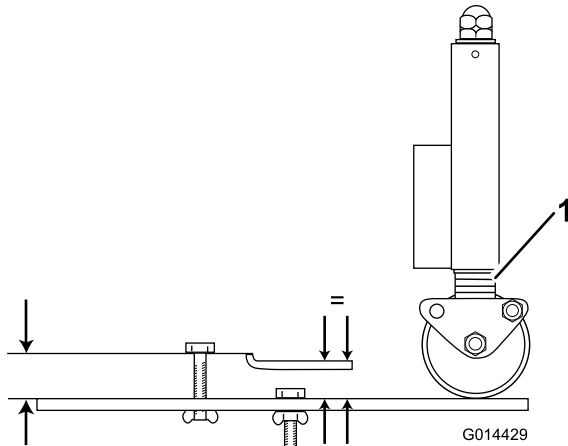

Figure 39

1. Indicator rings

MK3 Floating Cutterhead 8 inch (20 cm)

Pivot knuckle fixing: Secure the bolt in the rear floating slot position Figure 40 as shown.

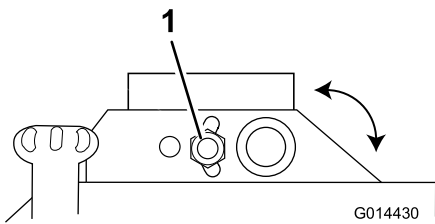

Figure 40

1. Rear floating slot position

Height of cut adjustment: The height of cut is gauged by the position of the front and rear rollers.

To alter the rear roller position, turn the adjusting nut assembly both ends clockwise to decrease height of cut or anti-clockwise to increase height-of-cut (Figure 41).

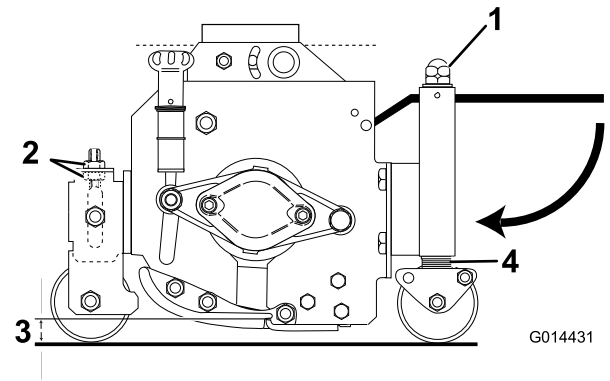

Figure 41

1. Adjusting nut assembly
2. Adjusting nuts
3. Height-of-cut
4. Indicator rings

Important: Do not attempt to unlock the nut assemblies.

To alter the front roller position loosen bolts. Release and turn adjusting nuts both ends clockwise to increase the height of cut or anti-clockwise to decrease the height of cut (Figure 42).

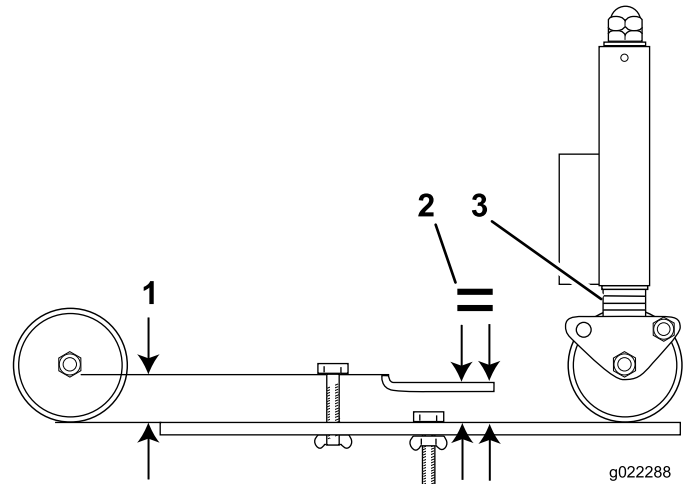

Figure 42

1. Height-of-cut
2. Equal
3. Indicator rings

Ensure that all cutterheads are set at the same height of cut by referring to the indicator ring or use the height of cut gauge across the full width of each cutterhead as shown (Figure 42).

Tighten nuts on both ends.

Centre Cutterhead Height of Cut Correction Adjustment

With all cutterheads set at the same HOC via the indicator rings, it may be noticeable that the center unit produces a higher cut finish compared to the wing units. The center unit is pulled and the wing units are pushed, this presents marginally different cutting angles relative to the ground. The amount of HOC variation, which results from this, will be influenced by the terrain but satisfactory results can usually be achieved by setting the center cutterhead HOC indicator ring lower than the wing unit settings.

Cutterhead Position Control

The cutterheads may be raised or lowered independently using the bank of 3 lift control switches.

1. To lower the cutterheads, operate the lift control switches in a downward direction and release.

The cutterhead drive switch must be on (forward) to do this, the cylinder drive will engage when the cutterheads are approximately 150 mm (6") above ground level. The cutterhead (s) are now in 'float' mode and will follow the ground contours.

2. To raise the cutterheads, operate the lift control switches in an upward direction and hold in position 3. If the cutterhead drive switch is in the **On** position the cylinder drive will disengage immediately.
3. Release the lift control switches when the cutterheads are at the required height.

The control switches will automatically return to position 2 (neutral) and the arms are hydraulically locked into position.

Adjusting the Cutterhead Auto Limited Lift

To activate, press the Auto Limited Lift switch to the ON position.

To deactivate, press the Auto Limited Lift switch to the OFF position.

Manual limited lift using the three lift control switches is always available regardless of the position of the Auto switch.

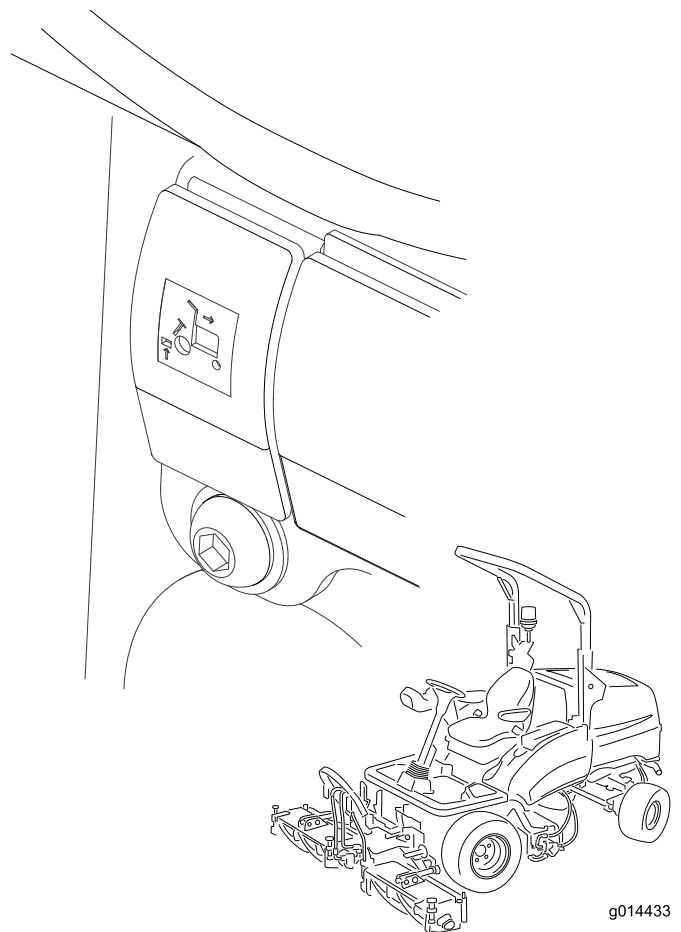

Figure 43

g014433

To raise the cutterheads to the limited lift position: momentarily operate the switches in an upward direction.

The cylinder drive will disengage immediately and the cutterheads will stop raising, approximately 150 mm (6 inches) above ground level.

This operates with the cutterheads lowered and rotating.

Auto limited lift in reverse causes the cutterheads to rise automatically to the limited lift position when reversing. They will return to the floating position when returning to forward travel. The cutting cylinders continue to rotate during this operation.

Engaging the Cutterhead Drive

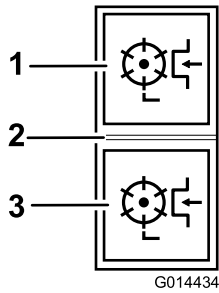

Figure 44

1. Forward
2. Off
3. Reverse

The cutterhead drive can be engaged only when the operator is seated correctly, refer to Operator Presence Seat Switch (page 44).

Forward rotation cutterhead drive engagement: Depress the top of the cutterhead drive switch to the forward position.

Reverse rotation cutterhead drive engagement: Depress the bottom of the cutterhead drive switch to the reverse position.

All cutterhead drives disengagement: Set the switch to the middle position.

To lower the cutterheads: The cutterhead drive switch must be set to forward. Operate the lift control switch(s) in a downward direction. The cylinder will drive when the cutterheads are approximately 150 mm (6 inches) above ground level.

Clearing the Cutting Cylinders

⚠ WARNING

Never attempt to rotate the cutting cylinders by hand.

- There may be some residual pressure in the hydraulic system which could cause injury through sudden movement of the cylinder(s) when the blockage is released.
- Always wear protective gloves and use a suitable strong wooden instrument.
- Ensure that the wooden instrument will fit between the blades and through the cylinder and is long enough to provide sufficient leverage to release the blockage.

1. Stop the machine on level ground.
2. Apply the parking brake and disengage all drives.
3. Lower the cutting units to the ground or securely lock in the designated transport positions.

4. Stop the engine and remove the ignition key to isolate all power sources and check that they are stopped.
5. Release all stored energy devices.
6. Check that all moving parts are stationary.
7. Using a suitable strong wooden instrument, remove the blockage. Make sure that the wooden instrument is properly supported in the cylinder and avoid the use of excessive force to prevent damage.
8. Ensure that the wooden instrument is removed from the cutting cylinder before restarting the power source.
9. Repair or adjust the cylinder if required.

Using Weight Transfer/Traction Assistance

A variable hydraulic weight transfer system is provided for improving tyre grip with the grass surface - traction assistance.

Hydraulic pressure in the cutterheads lift system provides a lifting force which reduces cutterheads weight on the ground and transfers the weight as a downward force onto the mower's tyres. This action is known as weight transfer.

To engage weight transfer: The amount of weight transfer can be varied to suit operating conditions by rotating the weight transfer hand wheel as follows:

1. Release the valve lock nut 1/2 turn anti-clockwise and hold.
2. Rotate the valve hand wheel.
 - Anti-clockwise to reduce weight transfer.
 - Clockwise to increase weight transfer.
3. Tighten the nut.

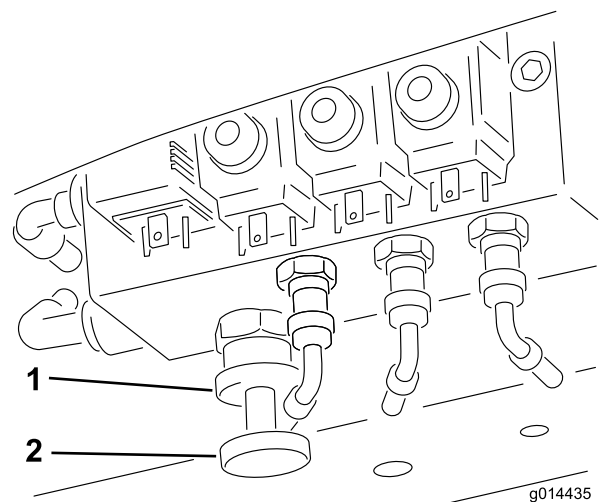

Figure 45

1. Lock Wheel
2. Weight transfer hand wheel

Folding the R.O.P.S.

The R.O.P.S frame may be folded down to allow access into areas of restricted height.

⚠ WARNING

While the R.O.P.S frame is folded down it does not provide any protection in the event of a roll-over and should not be considered as a Roll Over Protective Structure.

1. Apply the parking brake and switch off the engine.
2. Support the weight of the upper frame while removing the hand nuts, washers and retaining bolts from the pivot brackets (Figure 46).
3. Carefully lower the frame downwards until it rests on the stops.
4. Insert the retaining bolts in the lower holes and fully tighten the hand nuts to support the upper frame in its lowered position.
5. To raise the frame, follow these instructions in reverse order.

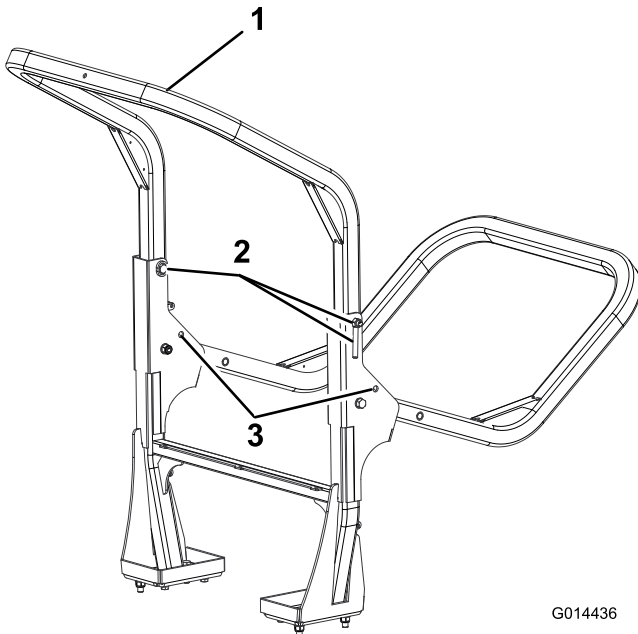

G014436

Figure 46

- | | |
|---|----------------|
| 1. Upper frame | 3. Lower holes |
| 2. Hand nuts, washers and retaining bolts | |

⚠ WARNING

Be careful lowering and raising the R.O.P.S frame to prevent entrapment of fingers between fixed part and pivot part of the structure.

- Keep all nuts, bolts and screws correctly torqued ensure that the equipment is in safe working condition.
- Replace worn or damaged parts for safety.
- Ensure that the Seat Belt and Mountings are in safe working order.
- Wear the seat belt when the roll bar is raised and no seat belt when the roll bar is lowered.

Important: The roll bar is an integral and effective safety device. Keep the roll bar in the raised position when operating the mower. Lower the roll bar temporarily only when absolutely necessary.

Jacking Points

Note: Use jack stands to support the machine when required.

- Front—under the front arm mount.
- Rear—axle tube on the rear axle.

⚠ WARNING

When in the raised position, both retaining bolt assemblies must be installed and fully tightened to ensure full R.O.P.S protection.

Operating Tips

Familiarization

Before mowing grass, practice operating the machine in an open area. Start and stop the engine. Operate in forward and reverse. Lower and raise the cutting units and engage and disengage the cutterheads. When you feel familiar with the machine, practice operating up and down slopes at different speeds.

Warning System

If a warning light comes on during operation, stop the machine immediately and correct the problem before continuing operation. Serious damage could occur if you operate the machine with a malfunction.

Mowing

The rotational speed of the cutting cylinders should always be kept as high as possible in order to maintain the highest quality of cut. This in turn requires that the engine speed be kept as high as possible.

Cutting performance is best when cutting against the lie of the grass. In order to take advantage of this fact, the operator should attempt to alternate the direction of mowing between cuts.

Take care not to leave uncut strips of grass at the overlap points between adjacent cutterheads by avoiding tight turns.

Quality of Cut

The quality of cut will deteriorate if the forward speed is excessive. Always balance the quality of cut with the work rate required and set the forward speed accordingly.

Engine

Never let the engine labour. Reduce the forward speed or increase the height of cut. Check that the cutting cylinders are not in heavy contact with their bottom blades.

Transporting

Always disengage the cutterhead drive when travelling across un-grassed areas. Grass will lubricate the cutting edges whilst mowing. Excessive heat will build up if the cutting cylinders are run when not mowing and this will cause rapid wear to take place. For this reason it is also wise to reduce cutting speed when mowing lightly grassed areas or when the grass is dry. Be careful when driving between objects so you do not accidentally damage the machine or cutting units.

▲ WARNING

Take care when travelling over obstacles such as roadside kerbs. Always travel at slow speed over obstacles to prevent damage to the machines tyres, wheels and steering system. Ensure that tyres are inflated to the recommended pressures.

Slopes

Use extra care when operating the machine on slopes. Drive slowly and avoid sharp turns on slopes to prevent roll overs. Lower the cutting units when going downhill for steering control.

Rear Roller Scrapers

It is generally wise to remove rear roller scrapers where conditions allow, as optimum grass discharge is achieved without them. Scrapers should be refitted when conditions are such that mud and grass start to build up on the rollers. When refitting the scraper wires care must be taken to ensure that they are correctly tensioned.

Maintenance

Note: Determine the left and right sides of the machine from the normal operating position.

Recommended Maintenance Schedule(s)

Maintenance Service Interval	Maintenance Procedure
After the first 8 hours	<ul style="list-style-type: none"> • Check the condition and tension of the alternator belt.
After the first 50 hours	<ul style="list-style-type: none"> • Change the engine oil and filter. • Change the transmission oil filter. • Change the hydraulic return filter. • Check the engine RPM (idle and full throttle).
Before each use or daily	<ul style="list-style-type: none"> • Check the engine oil level. • Check the cooling system. • Check fuel level. • Check the hydraulic fluid level. • Torque the wheel lug nuts. • Check the cylinder to bedknife contact. • Check the tyre pressure. • Check the air cleaner blockage indicator. (Service the air cleaner earlier if the air cleaner indicator shows red. Service it more frequently in extremely dirty or dusty conditions.) • Remove debris from the screen, oil coolers, and radiator (more frequently in dirty operating conditions). • Check safety interlock system. • Check the hydraulic lines and hoses for leaks, kinked lines, loose mounting supports, wear, loose fittings, weather deterioration, and chemical deterioration.
Every 50 hours	<ul style="list-style-type: none"> • Grease the bearings, bushings and pivots (Grease them immediately after every washing regardless of the interval listed.) • Check cutterhead rear bearing adjustment. • Check Rear Roller Scraper Wire Tension
Every 100 hours	<ul style="list-style-type: none"> • Inspect the cooling system hoses. • Check the condition and tension of the alternator belt.
Every 150 hours	<ul style="list-style-type: none"> • Change the engine oil and filter.
Every 200 hours	<ul style="list-style-type: none"> • Drain moisture from the fuel and hydraulic fluid tanks.
Every 250 hours	<ul style="list-style-type: none"> • Check Battery Condition • Check the transmission control cable. • Check the condition of and clean the battery. • Check the battery cable connections.
Every 400 hours	<ul style="list-style-type: none"> • Check the fuel lines and connections. • Check the engine RPM (idle and full throttle).
Every 500 hours	<ul style="list-style-type: none"> • Check Engine Overheat Warning System • Replace the primary air filter. (More frequently in extreme dusty or dirty conditions) • Replace the fuel filter • Check Electrical System • Change the transmission oil filter. • Change the hydraulic return filter. • Check the rear wheel alignment. • Service the Hydraulic System • Check Hydraulic Oil Overheat Warning System • Replace the fuel filter.
Every 800 hours	<ul style="list-style-type: none"> • Drain and clean the fuel tank • Adjust the engine valves (refer to the engine Operator's Manual)

Maintenance Service Interval	Maintenance Procedure
Before storage	<ul style="list-style-type: none"> • Drain and clean the fuel tank
Every 2 years	<ul style="list-style-type: none"> • Flush and replace the cooling system fluid. • Replace all moving hoses.

Daily Maintenance Checklist

Duplicate this page for routine use.

Maintenance Check Item	For the week of:						
	Mon.	Tues.	Wed.	Thurs.	Fri.	Sat.	Sun.
Check the safety interlock operation.							
Check the brake operation.							
Check the engine oil and fuel level.							
Check the air filter restriction indicator.							
Check the radiator and screen for debris.							
Check unusual engine noises. ¹							
Check unusual operating noises.							
Check the hydraulic system oil level.							
Check hydraulic hoses for damage.							
Check for fluid leaks.							
Check the tyre pressure.							
Check the instrument operation.							
Check the cylinder-to-bedknife adjustment.							
Check the height-of-cut adjustment.							
Check all grease fittings for lubrication. ²							
Touch-up damaged paint.							
<p>1. Check the glow plug and injector nozzles if hard starting, excess smoke, or rough running is noted.</p> <p>2. Immediately after every washing, regardless of the interval listed</p>							

Notation for Areas of Concern

Inspection performed by:		
Item	Date	Information
1		
2		
3		
4		
5		
6		
7		
8		

Important: Refer to your *Engine Operator's Manual* for additional maintenance procedures.

Pre- Maintenance

Before performing any maintenance ensure the engine is switched to off and the ignition key is removed, the parking brake is set, there is no pressure in the hydraulic system, the cutterheads are down on the ground and the safety precautions in this manual have been read and understood.

⚠ CAUTION

If you leave the key in the ignition switch, someone could accidentally start the engine and seriously injure you or other bystanders.

Remove the key from the ignition before you do any maintenance.

Important: Regular maintenance is essential for the continued safe operation of the machine. Correct servicing will prolong the working life of the machine and safeguard the Warranty. Always use genuine TORO service parts as these are accurately matched to the required duty.

Dirt and contamination are the enemies of any hydraulic system. When carrying out maintenance procedures on the hydraulic system always ensure that the work area and the components are thoroughly clean before, during and after refitting. Ensure that all open hydraulic lines and ports, etc. are plugged during maintenance procedures.

The recommended service intervals are based on normal operating conditions. Severe or unusual conditions will necessitate shorter service intervals.

Always grease the pivot points immediately after pressure washing or steam cleaning.

⚠ WARNING

The engine, transmission oil and hydraulic systems will be hot after machine use. Allow the systems to cool before working on the machine, particularly before working on the engine or when changing oil or oil filters.

Service Interval Chart

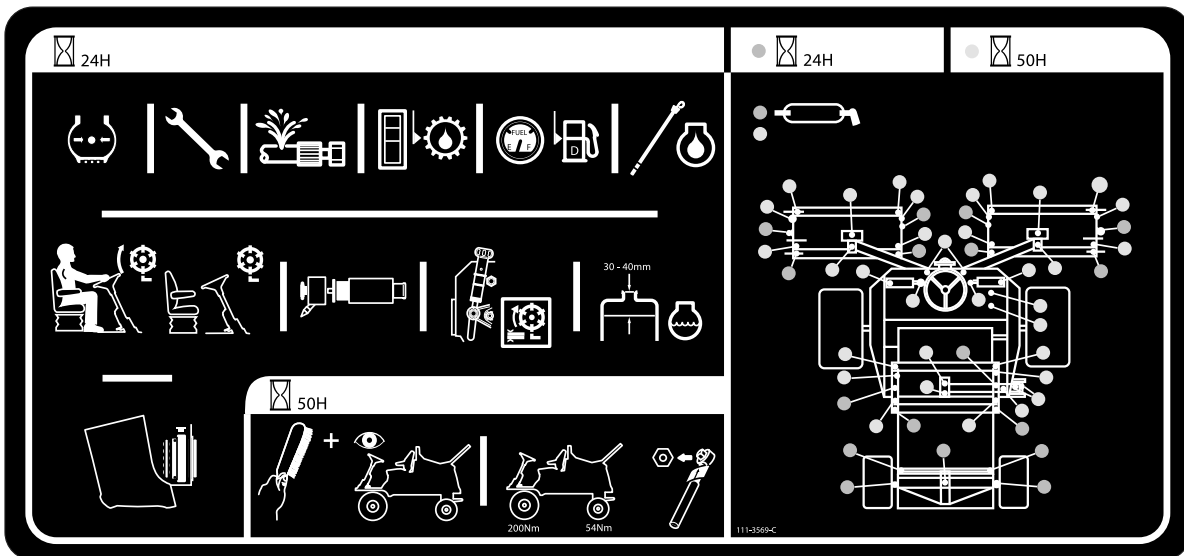

g022393

Figure 47

Lubrication

Greasing the Bearings, Bushings and Pivots

Service Interval: Every 50 hours

Lubricate all grease fittings for the bearings and bushings with No. 2 General Purpose Lithium Base Grease. Lubricate bearings and bushings **immediately** after every washing, regardless of the interval listed.

Replace any grease zerks that become damaged.

Grease all cutterhead grease points and ensure that sufficient grease is injected such that clean grease is seen to escape from the roller end caps. This provides visible evidence that the roller seals have been purged of grass debris etc. and will ensure maximum working life.

The grease fitting locations and quantities are as follows:

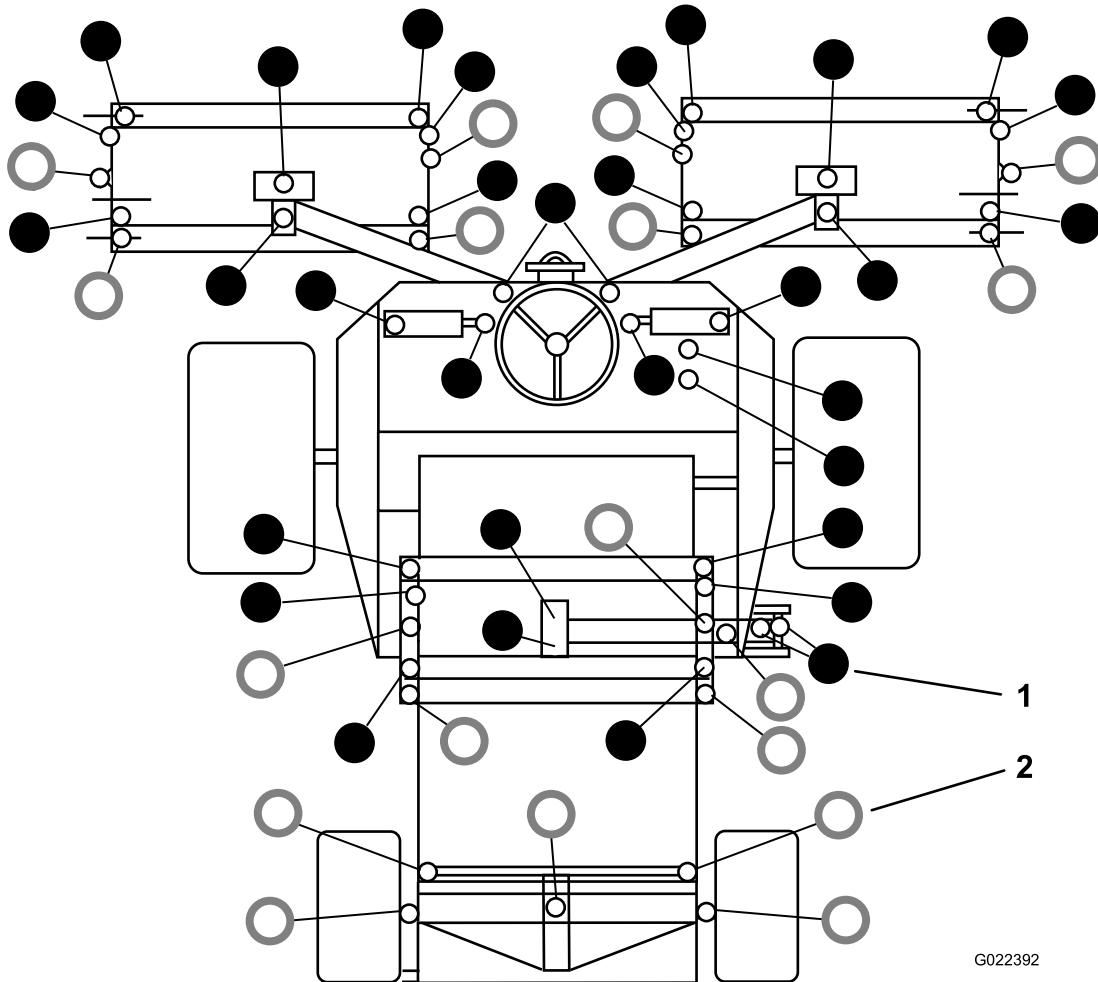

Figure 48

1. ● – Grease every 50 hours

2. ○ – Grease every 25 hours

Engine Maintenance

Check the Engine Overheat Warning System

Service Interval: Every 500 hours

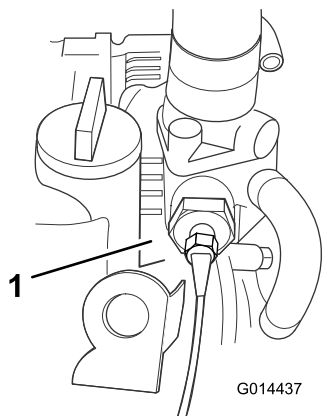

Figure 49

1. Temperature switch

1. Turn the ignition key to the ignition on position I.
2. Disconnect the red/blue wire terminal from the engine temperature switch.
3. Touch the metal terminal of this wire onto a suitable earth point, ensuring that the metal surfaces make good contact.

The horn will sound and the engine coolant temperature warning light will illuminate to confirm correct operation. If the system is faulty, make repairs before operating the mower.

Servicing the Air Cleaner

Service Interval: Before each use or daily

Every 500 hours

Servicing the Primary Air Filter

Check the air cleaner body for damage which could cause an air leak. Replace if damaged. Check the whole intake system for leaks, damage or loose hose clamps.

Service the primary air cleaner filter only when the service indicator (Figure 50) requires it. Changing the air filter before it is necessary only increases the chance of dirt entering the engine when the filter is removed.

Important: Be sure the cover is seated correctly and seals with the air cleaner body.

1. Check the filter blockage indicator. If the indicator is red, the air filter needs to be replaced (Figure 50).

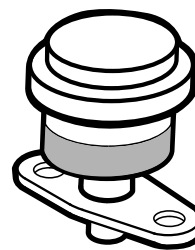

G014565

Figure 50

2. Before removing the filter, use low pressure air (40 psi, clean and dry) to help remove large accumulations of debris packed between outside of the filter and the canister. **Avoid using high pressure air which could force dirt through the filter into the intake tract.** Remove the cover from the air cleaner body.

This cleaning process prevents debris from migrating into the intake when the filter is removed.

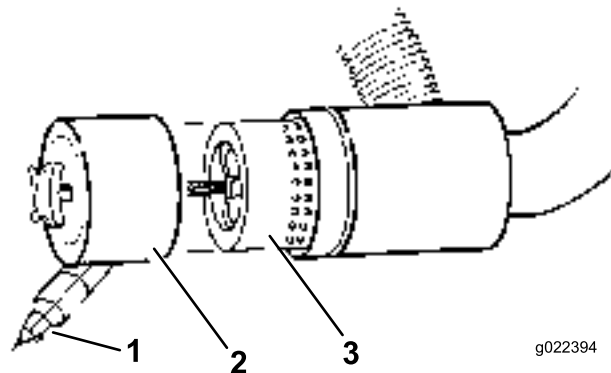

g022394

Figure 51

1. Dust boot
2. Dust bowl
3. Air filter

3. Remove and replace the filter (Figure 51).

Cleaning of the used element is not recommended due to the possibility of damage to the filter media.

4. Inspect the new filter for shipping damage, checking the sealing end of the filter and the body. **Do not use a damaged element.**
5. Insert the new filter by applying pressure to the outer rim of the element to seat it in the canister. **Do not apply pressure to the flexible center of the filter.**
6. Clean the dirt ejection port located in the removable cover. Remove the rubber outlet valve from the cover, clean the cavity and replace the outlet valve.
7. Install the cover orienting the rubber outlet valve in a downward position—between approximately 5:00 to 7:00 when viewed from the end.
8. Check the condition of the air cleaner hoses.
9. Secure the cover.

Servicing the Safety Filter

The air filter has a secondary, safety filter element inside the primary air filter to prevent dislodged dust and other items from entering the engine while changing the main element.

Replace the safety filter, never clean it.

Important: Never attempt to clean the safety filter. If the safety filter is dirty, then the primary filter is damaged. Replace both filters.

Servicing the Engine Oil and Filter

Service Interval: After the first 50 hours

Every 150 hours

1. Remove the drain plug (Figure 52) and let the oil flow into a drain pan.

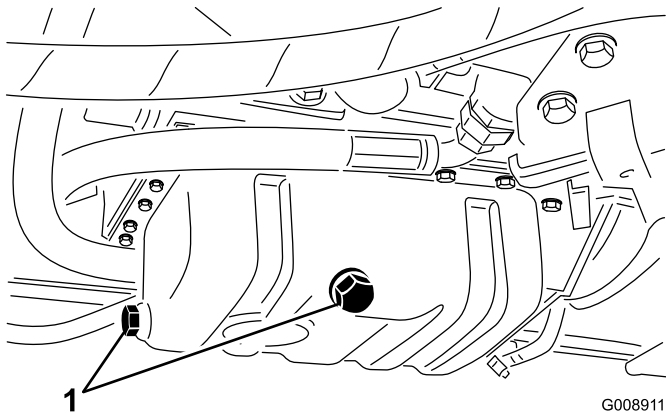

Figure 52

1. Oil drain plug

2. When the oil stops, install the drain plug.
3. Remove the oil filter (Figure 53).

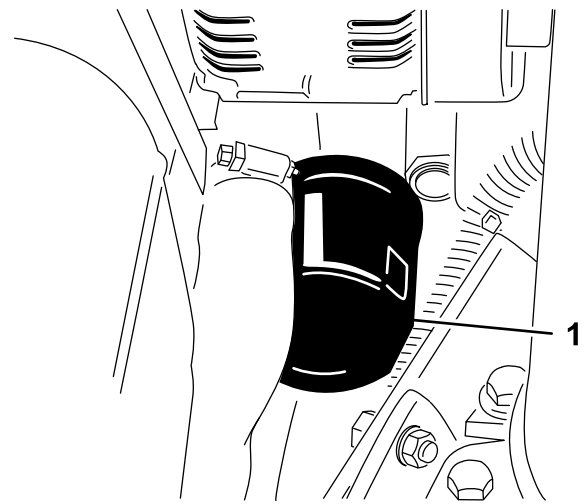

Figure 53

1. Oil filter

4. Apply a light coat of clean oil to the new filter seal.
5. Install the replacement oil filter to the filter adapter. Turn the oil filter clockwise until the rubber gasket contacts the filter adapter, then tighten the filter an additional 1/2 turn.

Important: Do not over-tighten the filter.

6. Add oil to the crankcase; refer to Checking the Engine Oil.

Fuel System Maintenance

⚠ DANGER

Under certain conditions, diesel fuel and fuel vapors are highly flammable and explosive. A fire or explosion from fuel can burn you and others and can cause property damage.

- Use a funnel and fill the fuel tank outdoors, in an open area, when the engine is off and is cold. Wipe up any fuel that spills.
- Do not fill the fuel tank completely full. Add fuel to the fuel tank until the level is 6 to 12 mm (1/4 to 1/2 inches) below the bottom of the filler neck. This empty space in the tank allows the fuel to expand.
- Never smoke when handling fuel, and stay away from an open flame or where fuel fumes may be ignited by a spark.
- Store fuel in a clean, safety-approved container and keep the cap in place.

Draining the Fuel Tank

Service Interval: Every 800 hours

Before storage

Drain and clean the fuel tank if the fuel system becomes contaminated or if the machine is to be stored for an extended period. Use clean fuel to flush out the tank.

Checking the Fuel Lines and Connections

Service Interval: Every 400 hours/Yearly (whichever comes first)

Check the fuel lines and connections. Inspect them for deterioration, damage, or loose connections.

Bleeding the Fuel System

You must bleed the fuel system before starting the engine if any of the following situations have occurred:

- Initial start up of a new machine.
- Engine has ceased running due to lack of fuel.
- Maintenance has been performed upon fuel system components; i.e., filter replaced, separator serviced, etc.

⚠ DANGER

Under certain conditions, diesel fuel and fuel vapors are highly flammable and explosive. A fire or explosion from fuel can burn you and others and can cause property damage.

- Use a funnel and fill the fuel tank outdoors, in an open area, when the engine is off and is cold. Wipe up any fuel that spills.
 - Do not fill the fuel tank completely full. Add fuel to the fuel tank until the level is 6 to 12mm (1/4 to 1/2 inches) below the bottom of the filler neck. This empty space in the tank allows the fuel to expand.
 - Never smoke when handling fuel, and stay away from an open flame or where fuel fumes may be ignited by a spark.
 - Store fuel in a clean, safety-approved container and keep the cap in place.
1. Park the machine on a level surface and ensure that the fuel tank is at least half full.
 2. Open the hood.
 3. Turn the key in the ignition switch to the ON position and crank the engine. The mechanical pump will suck fuel out of the tank, fill the fuel filter and fuel hose and force the air into the engine. This could take some time to fully purge all the air out of the system and the engine might fire erratically until all air is purged out. When all air is purged and the engine is running smoothly, it should be run for a few minutes to ensure that it is fully purged.

Replacing the Fuel Filter

Service Interval: Every 500 hours

Important: Replace the fuel filter canister periodically to prevent wear of the fuel injection pump plunger or the injection nozzle, due to dirt in the fuel.

1. Place a clean container under the fuel filter canister (Figure 54).
2. Clean the area where the filter canister mounts.

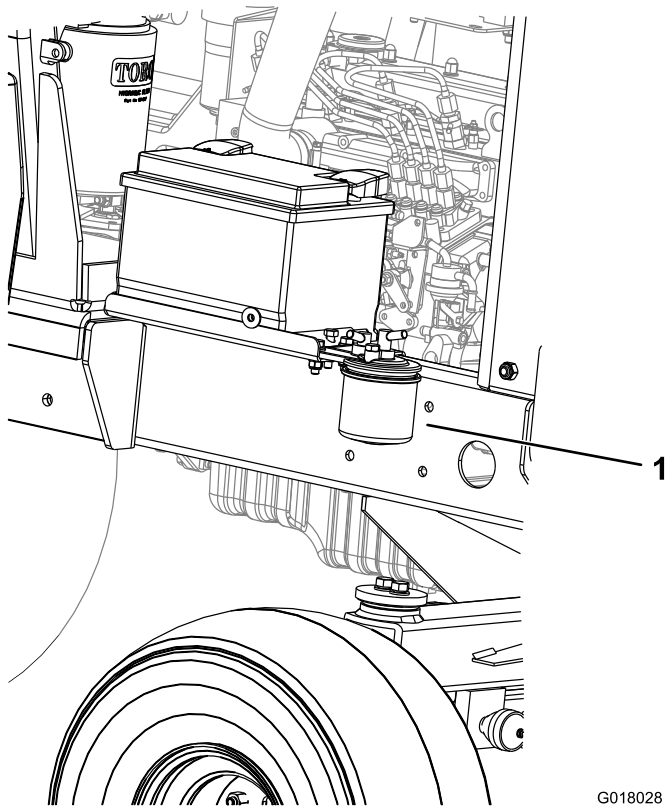

Figure 54

1. Fuel filter

-
3. Remove the filter canister and clean the mounting surface.
 4. Lubricate the gasket on the filter canister with clean oil.
 5. Install the new filter canister by hand until the gasket contacts mounting surface.
 6. Bleed the fuel system; refer to Bleeding the Fuel System.

Electrical System Maintenance

Important: Before welding on the machine, disconnect both cables from the battery, both wire harness plugs from the electronic control module, and the terminal connector from the alternator to prevent damage to the electrical system.

Check Electrical System

Service Interval: Every 500 hours

Inspect all electrical connections and cables and replace any which are damaged or corroded. Spray a good quality water inhibitor onto exposed connections to prevent moisture ingress.

Check Battery Condition

Service Interval: Every 250 hours

Note: When removing the battery, always disconnect the negative (-) cable first.

Note: When installing the battery, always connect the negative (-) cable last.

Raise the engine cover. Remove any corrosion from the battery terminals using a wire brush and apply petroleum jelly to the terminals to prevent further corrosion. Clean the battery compartment.

Under normal operating conditions the battery will not require any further attention. If the machine has been subject to continuous use under high ambient temperature conditions, the battery electrolyte may require topping up.

Remove the cell covers and top up with distilled water to a height 15 mm below the top of the battery. Install the cell covers.

Note: Check the condition of the battery cables. Install new cables when current ones are showing signs of wear or damage and tighten any loose connections as necessary.

Inspect Transmission Control Cable and Operating Mechanism

Service Interval: Every 250 hours

Check the condition and security of the cable and operating mechanism at the speed control pedals and transmission pump ends.

- Remove build up of dirt, grit and other deposits.
- Ensure that the ball joints are securely anchored and check that mounting brackets and cable anchors are tight and free from cracks.

- Inspect end fittings for wear, corrosion, broken springs, and replace if necessary.
- Ensure that the rubber seals are correctly located and are in good condition.
- Ensure that the articulating sleeves supporting the inner cable are in good condition and firmly attached to the outer cable assembly at the crimped connections. If there are any signs of cracking or detachment install a new cable immediately.
- Check that sleeves, rods, and inner cable are free from bends, kinks, or other damage. If they are not, install a new cable immediately.
- With the engine switched off, operate the pedal controls through the entire range and ensure that the mechanism moves smoothly and freely to the neutral position without sticking or hanging up.

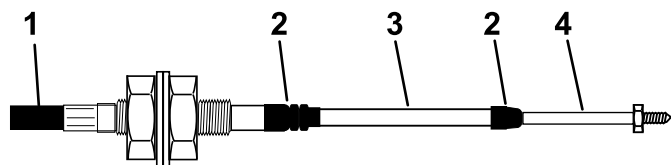

g014571

Figure 55

- | | |
|----------------|------------|
| 1. Outer cover | 3. Sleeve |
| 2. Rubber seal | 4. Rod end |

Servicing the Battery

Service Interval: Every 250 hours

⚠ DANGER

Battery electrolyte contains sulfuric acid which is a deadly poison and causes severe burns.

- **Do not drink electrolyte and avoid contact with skin, eyes, or clothing. Wear safety glasses to shield your eyes and rubber gloves to protect your hands.**
- **Fill the battery where clean water is always available for flushing the skin.**

⚠ WARNING

Charging the battery produces gasses that can explode.

Never smoke near the battery and keep sparks and flames away from it.

Check the battery condition. Keep the terminals and the entire battery case clean because a dirty battery will discharge slowly. To clean the battery, wash the entire case with a solution of baking soda and water. Rinse it with clear water.

Drive System Maintenance

Changing the Transmission Oil Filter

Service Interval: After the first 50 hours

Every 500 hours

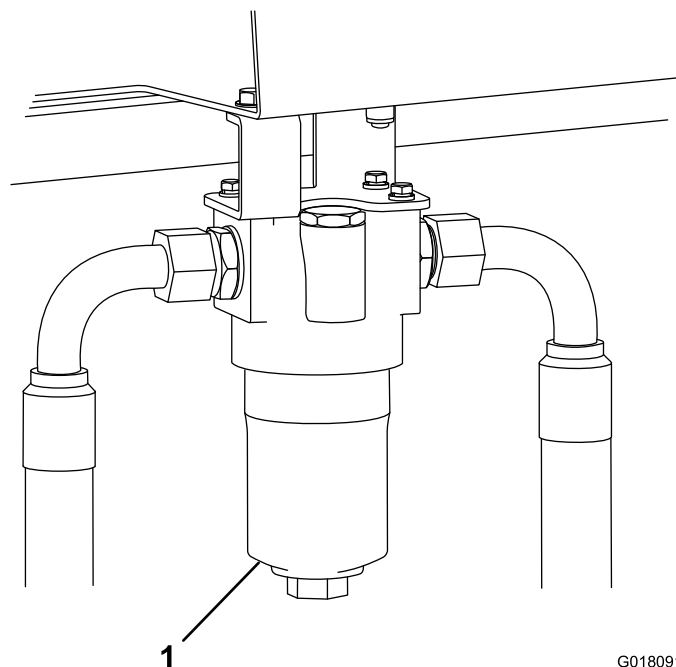

G018091

Figure 56

Right hand side of machine

1. Transmission oil filter

1. Unscrew and remove the bottom of the transmission oil filter housing.
2. Withdraw the filter element and discard.
3. Refit a new filter element (Part no. 924709).
4. Install the housing.

Changing the Hydraulic Return Filter

Service Interval: After the first 50 hours

Every 500 hours

1. Remove the return filter.
2. Wipe oil onto the new return filter gasket.
3. Install the new return filter to the machine.

Cooling System Maintenance

Removing Debris from the Cooling System

Service Interval: Before each use or daily

Every 100 hours

Every 2 years

1. Park the machine on a level surface, stop the engine, set the parking brake and remove the key from the ignition switch.
2. Clean the radiator screen.
3. Thoroughly clean all debris out of the engine area.
4. Release the latch and open the engine cover (Figure 59).

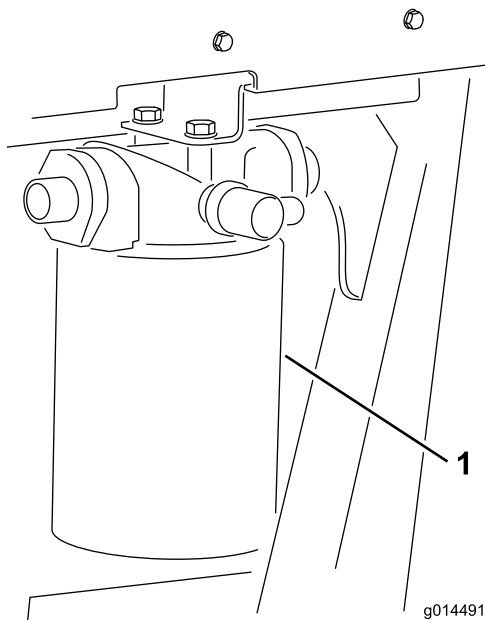

Figure 57

Left hand side of machine

1. Hydraulic oil return filter

Check Rear Wheel Alignment

Service Interval: Every 500 hours

To prevent excessive tyre wear and ensure safe machine operation, the rear wheels must be correctly aligned to 3-8 mm (0.12-0.31 inches).

Set the rear wheels in the straight ahead position. Measure and compare the distance between the front sidewalls and the rear sidewalls at the wheel centre height. The distance between the front sidewalls must be set 3-8 mm (0.12-0.31 inches) less than the distance between the rear sidewalls.

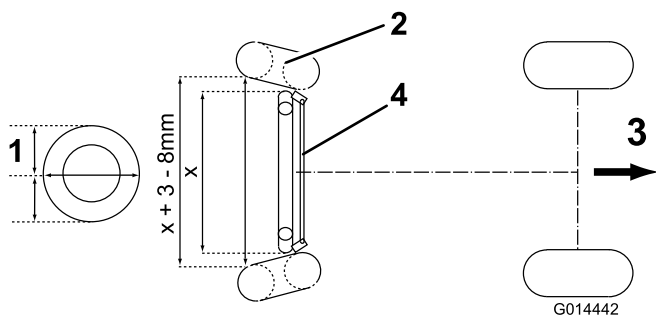

Figure 58

1. Wheel center height
2. Tyre
3. Direction of forward travel
4. Track-rod assembly

To adjust the alignment of the rear wheels, first back off the left hand and right hand locknuts on the track rod assembly. (Left hand locknut is a left hand thread). Rotate the track rod to achieve the correct distance as described above and tighten the locknuts securely.

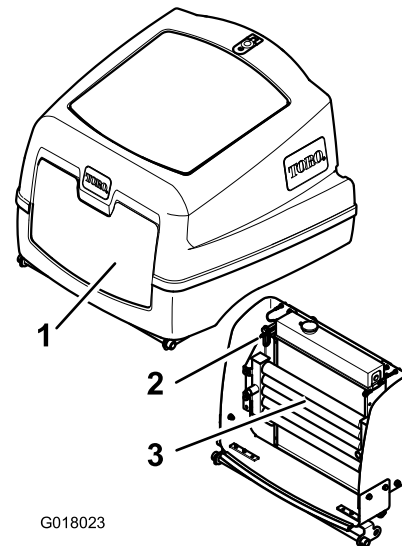

Figure 59

1. Engine cover
2. Oil cooler
3. Oil cooler release clip
5. Clean the screen thoroughly with compressed air.
6. Pivot the latch inward to release the oil cooler (Figure 60).

Brake Maintenance

Towing the Mower

Ensure that the towing vehicle specification is suited to braking the combined vehicle weight and able to remain in complete control at all times. Ensure the towing vehicle's parking brake is applied. Chock the mower front wheels to prevent the mower rolling away.

De-commission the front wheel motor disc brakes as follows :

1. Connect a rigid tow bar between the towing eye on the mower and a suitable towing vehicle.
2. Identify the right hand front wheel motor disc brake assembly and remove the hex plug (Figure 62).

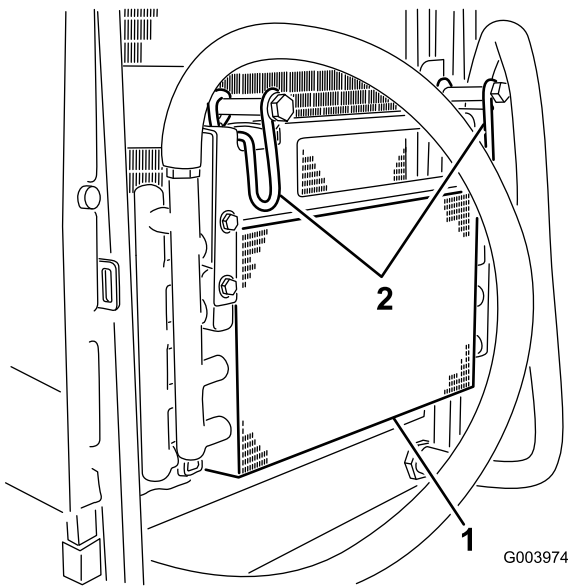

Figure 60

1. Oil cooler
2. Oil cooler latch

7. Thoroughly clean both sides of the oil cooler and the radiator (Figure 61) with compressed air.

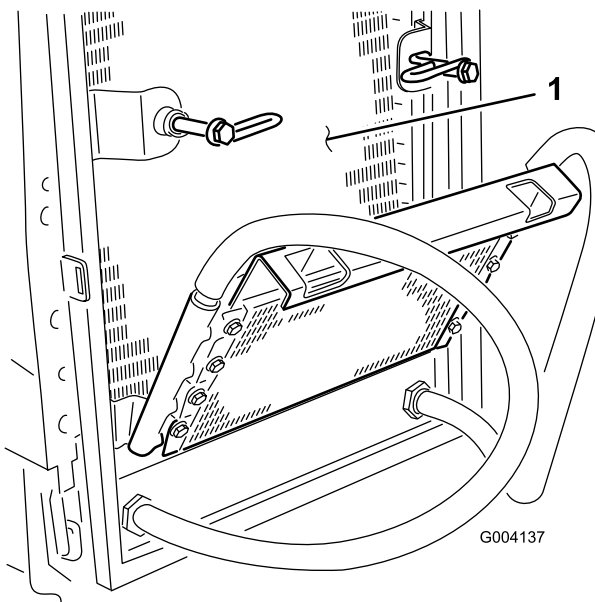

Figure 61

1. Radiator

8. Pivot the oil cooler back into position and secure the latch.
9. Close the engine cover and secure the latch.

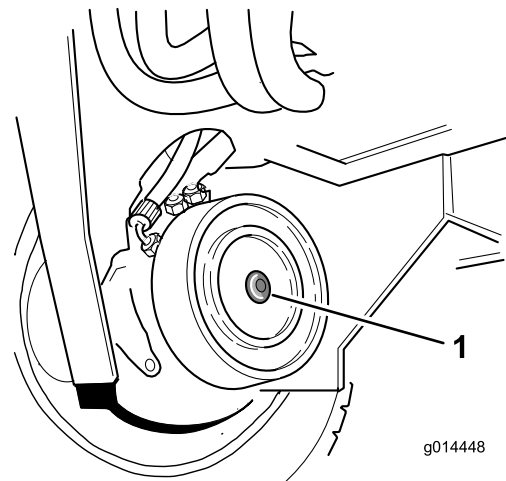

Figure 62

1. Hex plug 950639

3. Locate the M12 x 40 mm setscrew and washer stored underneath the operator platform, one in each of the platform support rails.
4. Install a M12 x 40 mm long setscrew with washer into the hole in the centre of the motor end plate (Figure 63).

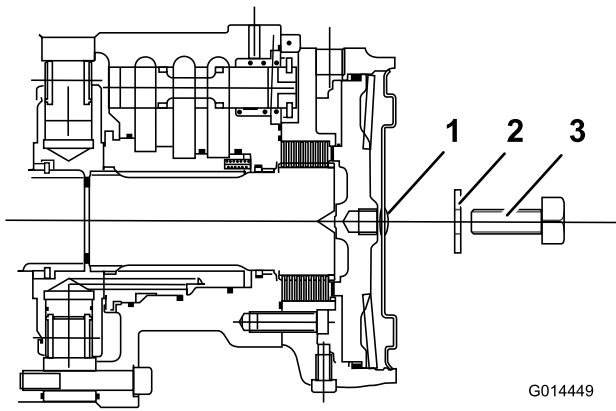

Figure 63

- | | |
|---------------------|----------------------------------|
| 1. Hex plug 950639 | 3. Setscrew M12 x 40 — ZDH1L040U |
| 2. Washer M12-09485 | |

5. Tighten the setscrew into the threaded hole in the brake piston until the brake is released (Figure 63).
6. Identify the left hand front wheel motor disc brake assembly and repeat the previous procedure (Figure 63).
7. De-commission the hydraulic service braking system by turning the bypass valve, located under the transmission pump, anti-clockwise, a maximum of three turns.

The steering must be operated manually when the mower is being towed. The steering will feel heavy as there is no hydraulic assistance when the engine is switched off.

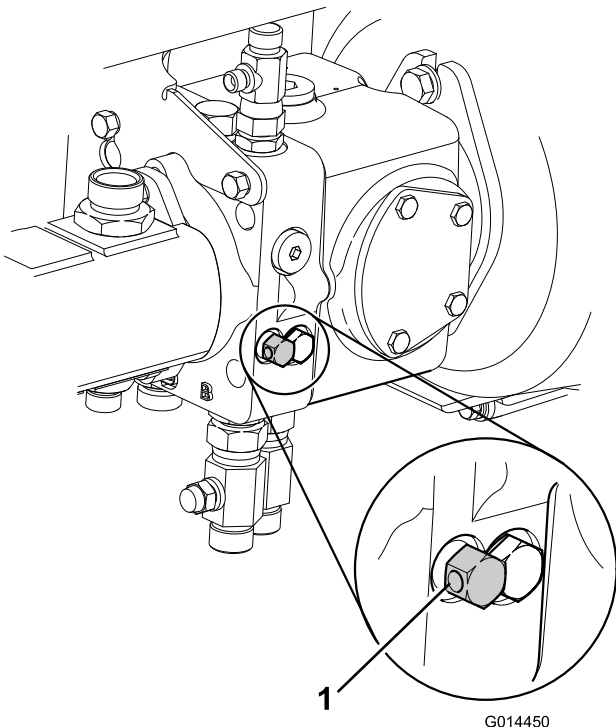

Figure 64

1. Transmission Bypass Valves

8. The mower is now in a free wheel condition and can be towed for a short distance at slow speed. Remove wheel chocks before towing.
9. **After towing the mower:** To return the mower to its normal working condition the following procedure must be done.
 - A. Chock the front wheels.
 - B. Close the bypass valve on the transmission pump by turning it clockwise.
10. **Commission the front wheel motor disc brakes as follows :**

Note: Ensure the M12 x 40 mm setscrews and washers are removed and stored underneath the operator platform.

- A. Identify the right hand front wheel motor disc brake assembly.
- B. Rotate the setscrew anti-clockwise and remove together.
- C. Assemble the hex plug into the motor end plate (Figure 65).

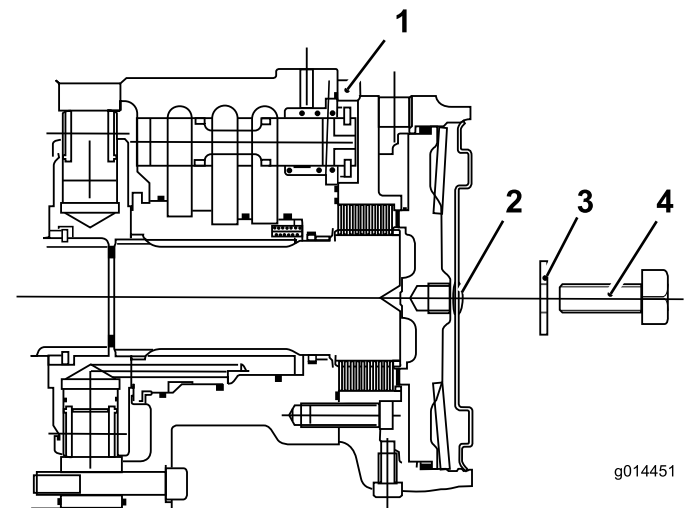

Figure 65

- | | |
|-------------------------------|------------------------------------|
| 1. Front wheel motor 111-2557 | 3. Washer M12-09485 |
| 2. Hex plug 950639 | 4. Setscrew M12 x 40 mm — XH1L040U |

- D. Identify the left hand front wheel motor disc brake assembly and repeat the previous procedure.
- E. Remove the wheel chocks.
- F. Disconnect the tow bar. The mower braking system will now operate in the normal way.

⚠ WARNING

Before using the mower, ensure that the braking system operates correctly. Carry out initial checks with the mower at slow speed. Do not operate the mower with a damaged braking system. Do not operate the mower with the brakes de-commissioned.

Belt Maintenance

Check the condition and tension of the alternator belt after the first day of operation and every 100 operating hours thereafter.

Tensioning the Alternator Belt

Service Interval: After the first 8 hours

Every 100 hours

1. Open the hood.
2. Check the tension of the alternator belt by depressing it (Figure 66) midway between the alternator and the crankshaft pulleys with 10 kg (22 lb) of force.

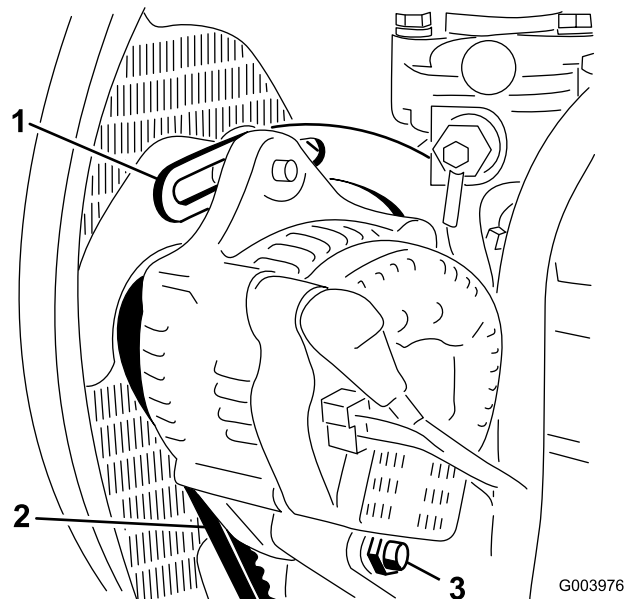

Figure 66

1. Brace
2. Alternator belt
3. Pivot bolt

The belt should deflect 11 mm (7/16 inch). If the deflection is incorrect, proceed to step 3. If correct, continue operation.

3. Loosen the bolt securing the brace to the engine (Figure 66), the bolt securing the alternator to the brace and the pivot bolt.
4. Insert a pry bar between the alternator and the engine and pry out on the alternator.
5. When you achieve the proper tension, tighten the alternator, brace and pivot bolts to secure the adjustment.

Controls System Maintenance

Check Forward/Reverse Travel Pedal Action

With the engine switched off, operate the forward and reverse travel pedals through the full range of articulation and ensure that the mechanism returns freely to the neutral position.

Operator Presence Seat Switch

Service Interval: Before each use or daily

1. Sit on the operator seat and start the engine.
2. Lower the cutterheads to the ground.
3. Engage the cutter drive in the forward direction.
4. Rise from the operators seat and check that the cutting cylinders come to a stop after an initial 0.5 to 1 second delay.
5. Repeat with the cutting cylinders running in reverse.

Cutter Drive Interlock Switch

1. Stop the mower engine.
2. Operate the cutter drive switch to the off position and turn the ignition key to position **I**. The cutterheads drive switch indicator light should not illuminate.
3. Operate the switch to the forward position. The indicator light should illuminate and the engine should not start when the ignition key is turned. Repeat for the reverse position.

Parking Brake Interlock Switch

1. Stop the engine.
2. Engage the parking brake.
3. Turn the ignition key to position **I**. The parking brake indicator light should illuminate.
4. Disengage the parking brake. The indicator light should go out and the engine should not start when the ignition key is turned.
5. Set the parking brake, sit on the operator seat and start the engine.
6. Release the parking brake.
7. Rise from the operator seat and check that the engine stops.

Transmission Neutral Interlock Switch

1. Stop the mower engine.
2. Remove your foot from the forward/reverse travel pedals.
3. Turn the ignition key to position **I** and the transmission neutral indicator light should illuminate.
4. Apply light pressure to the travel pedals in a forward and reverse direction to check that the indicator light turns off.

Note: Take extreme care to ensure that the area around the mower is clear before checking that the engine will not start under this condition.

Hydraulic System Maintenance

⚠ WARNING

Hydraulic fluid escaping under pressure can penetrate skin and cause injury.

- Make sure all hydraulic fluid hoses and lines are in good condition and all hydraulic connections and fittings are tight before applying pressure to the hydraulic system.
- Keep your body and hands away from pin hole leaks or nozzles that eject high pressure hydraulic fluid.
- Use cardboard or paper to find hydraulic leaks.
- Safely relieve all pressure in the hydraulic system before performing any work on the hydraulic system.
- Get immediate medical help if fluid is injected into skin.

Service the Hydraulic System

Service Interval: Every 500 hours

Note: Keep water away from electrical components. Use a dry cloth or brush to clean such areas.

This procedure is best carried out when the hydraulic oil is warm (not hot). Lower the cutterheads to the ground and drain the hydraulic system.

1. Remove the oil tank filler flange to gain access to the suction strainer.
2. Unscrew and remove the strainer and clean with paraffin or petrol before installing.
3. Install the return line oil filter element.
4. Install the transmission oil filter element.
5. Fill the hydraulic tank with fresh clean hydraulic oil of the recommended grade.
6. Run the machine and operate all hydraulic systems until the hydraulic oil is warm.
7. Check the oil level and top up as necessary to the upper mark on the sight level gauge.

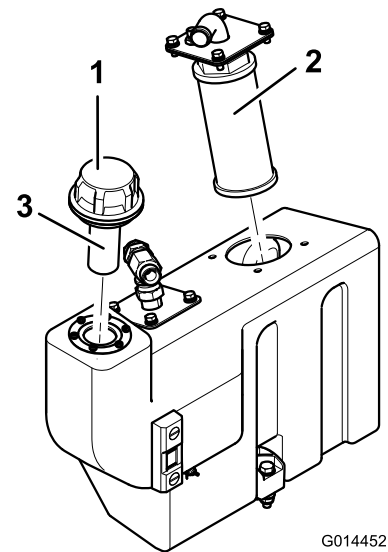

Figure 67

1. Oil tank filler cap
2. Suction strainer
3. Filler strainer

Check the Hydraulic Oil Overheat Warning System

Service Interval: Every 500 hours

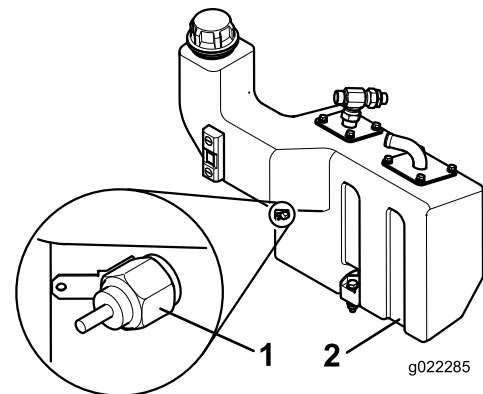

Figure 68

1. Temperature switch
2. Hydraulic oil tank

1. Turn the ignition key to the ignition on position I.
2. Disconnect the red/yellow wire terminal from the hydraulic tank temperature switch.
3. Touch the metal terminal of the wire onto a suitable earth point, ensuring that the metal surfaces make good contact.

The horn will sound and the hydraulic oil temperature warning light will illuminate to confirm correct operation. If necessary, make repairs before operating the mower.

Checking the Hydraulic Lines and Hoses

Daily, check hydraulic lines and hoses for leaks, kinked lines, loose mounting supports, wear, loose fittings, weather deterioration, and chemical deterioration. Make all necessary repairs before operating.

Cutterheads System Maintenance

Cutterheads Maintenance

Checking Cutterheads Rear Roller Bearing Adjustment

Service Interval: Every 50 hours

Important: It is essential that the cutterheads roller bearings are kept in good adjustment in order to ensure maximum working life. If roller end float is allowed to become excessive, premature bearing damage will result.

Grip the roller and move from side to side and up and down. If excessive movement is detected, proceed as follows:

Carefully tighten nuts (Figure 69) at each end of the roller with the spanner provided, just sufficiently to remove any end float.

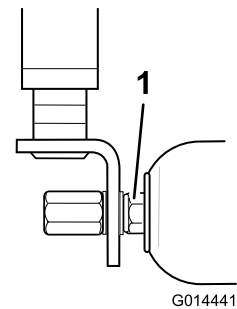

Figure 69

1. Nuts

Note: The roller should still rotate freely after adjustment. Overtightening of nuts (Figure 69) could lead to premature bearing damage.

Checking Cutterheads Rear Roller Scraper Wire Tension

Service Interval: Every 50 hours

It is important that the scraper wires are correctly tensioned so as to ensure that the correct operation and maximum working life. Carefully tighten the scraper wire retaining nuts so as to remove any slack from the scraper wires then tighten nuts a full four turns to correctly tension the wire (Figure 70).

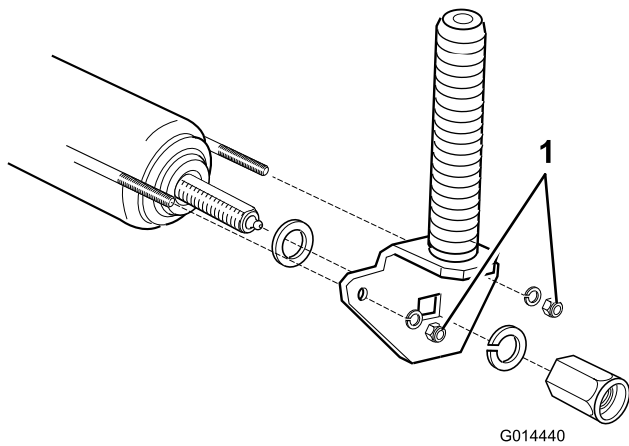

Figure 70

1. Scraper wire retaining nuts

Note: Do not over tighten the scraper wires.

Cutterhead Cylinder to Bottom Blade Adjustment

Important: It is essential that the relationship between the bottom blades and the cutting cylinders are kept in good adjustment in order to ensure good cutting performance, minimum power consumption and prolonged life for the cutting cones.

Do not be tempted to over adjust, thus causing heavy contact between the cylinder and bottom blade, as this will cause very rapid uneven wear to take place leading to tram lining and waviness of the cutting edges. The frictional losses will be high and a significant amount of power will be absorbed, thus reducing the power available for cutting. The heating effect due to friction will cause excessive expansion to take place which will further aggravate the situation by increasing the contact pressure.

If the cutterheads are allowed to operate for more than a few hours without adjustment, the running wear will eventually cause the cylinder to run out of contact with the bottom blade. At this stage very rapid rounding of the cutting edges will occur as grass and abrasive particles pass through the clearance between the blades.

Lack of attention to adjustments can result in maintenance costs escalating. The quality of cut will also be seriously affected as will the health and growth of the grass.

An experienced operator will notice when a cutterhead starts to go out of adjustment; when the grass ceases to be cut cleanly and the cut ends become ragged.

Carry out the following procedure before commencing work and check the settings every few hours.

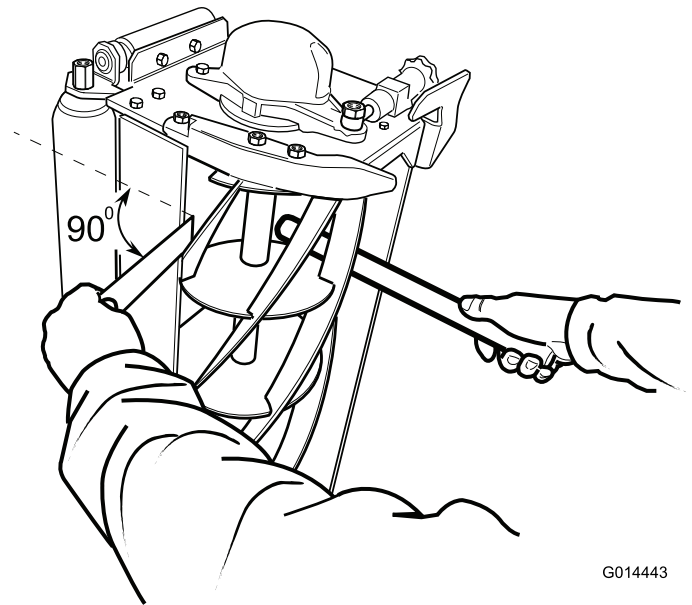

Figure 71

1. Check that the cutting cylinder is correctly set to the bottom blade by holding a thin piece of paper between the cutting cylinder and the bottom blade as shown.
2. Carefully rotate the cylinder as shown and check that the paper is cut cleanly at all points along the length of the blade. Hold the paper at a 90 degree right angle to the bottom blade to obtain the correct cutting action.

⚠ WARNING

Ensure that people are clear of the cutting cylinders as rotation of one may cause others to rotate.

3. If adjustment is necessary proceed as follows, release the nut (Figure 72) a 1/4 turn on both ends.
4. Turn hand wheel (Figure 72) each end alternately whilst rotating the cutting cylinder backwards until the bottom blade is in fleeting contact with the cylinder along its entire length.
5. Check the cutting action along the length of the bottom blade using a thin piece of paper making marginal adjustments as necessary.
6. Tighten nut (Figure 72) both ends.

If it is impossible to obtain a good clean paper cut across the entire length of the bottom blade it will be necessary to carry out the back lapping procedure to reprocess the cutting edges. In severe cases it will be necessary to regrind the cutting cylinder and the bottom blade.

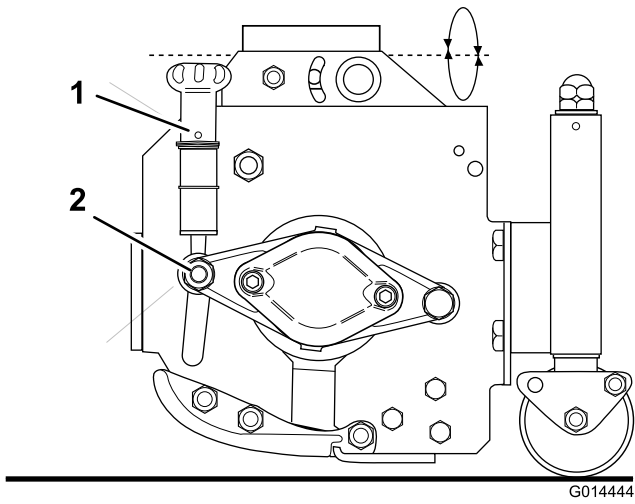
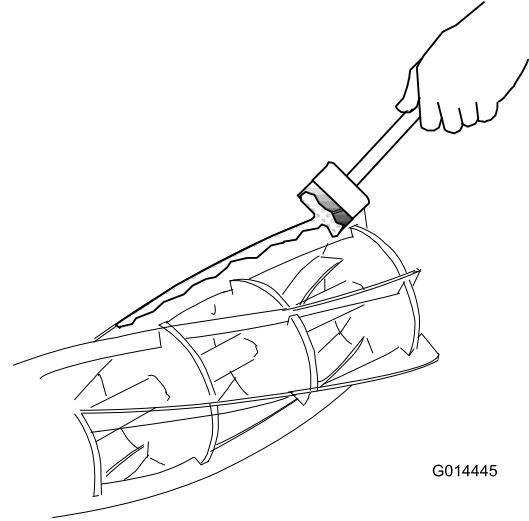

Figure 72

1. Hand wheel

2. Nut

80 Grade Carborundum paste	
	Part No.
1 lb (0.45 kg)	63-07-088
25 lb (11.25 kg)	63-07-086



G014445

Figure 73

Cutterheads Back Lapping

⚠ WARNING

Contact with the cutterheads or other moving parts can result in personal injury.

- Keep fingers, hands, and clothing away from the cutterheads or other moving parts.
- Never attempt to turn the cutterheads by hand or foot while the engine is running.

This process is recommended for restoring the sharp cutting edges to cylinders and bottom blades which are essential for good quality grass cutting.

This process can only deal with a small amount of metal removal to restore the cutting edges. If the blade edges are seriously worn or damaged it will be necessary to remove the component parts and have them reground.

1. Check that the mower engine is switched off and the parking brake applied.
2. Adjust the cutting cylinders to the bottom blades to obtain fleeting contact.
3. Apply a medium grade detergent based carborundum paste to the cutting edges of the cylinders with a long handled brush.

4. Ensure that the area surrounding the cutterhead heads is clear of people. Keep hands and feet clear of the cutting cylinders during the period when the mower engine is running.
5. Sit on the operator seat, start the mower engine and set the engine speed at idle.
6. Operate the cutterheads drive switch to the reverse/back lap position for a period of time and listen to the grinding action .

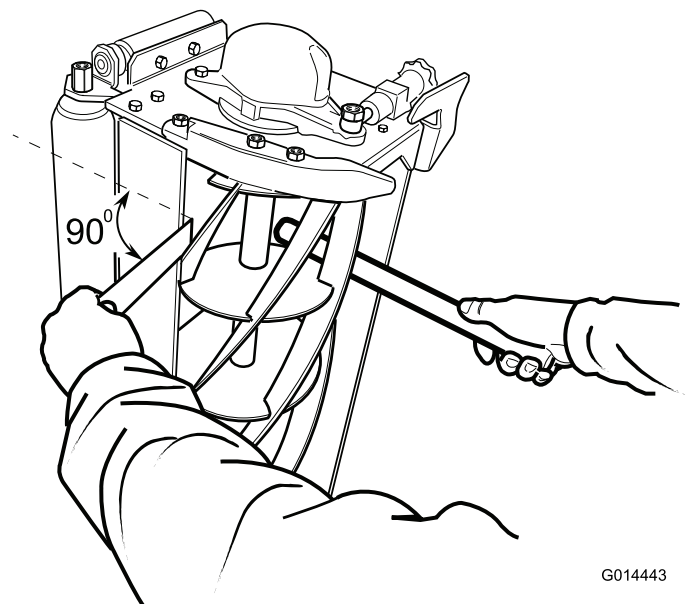

G014443

Figure 74

7. Operate the cutterheads drive switch to the off position and switch off the mower engine when the grinding action has stopped.
8. Thoroughly clean the blade edges and adjust the cutting cylinders to the bottom blades. Check that a thin piece of paper can be cut cleanly at all points along the cutting edges while rotating the cylinders by hand.
9. If further back lapping is necessary repeat steps 2–8.
10. Thoroughly remove and wash off all traces of the carborundum paste from the cylinders and bottom blades.

Cutterheads Grinding

It will be necessary to carry out a grinding operation to correct cylinder spiral edges or bottom blade edges which have become excessively rounded or distorted. Bottom blades which are nearing the end of their wear life should be replaced. The new blades should be ground on their holders prior to fitting. When grinding operations are necessary it is essential that both cylinders and bottom blades are ground at the same time. The only exception to this rule is when a new cylinder is fitted in which case it is only necessary to grind the bottom blade. All such grinding operations should be carried out by your authorized dealer on a quality, well maintained cylinder / bottom blade grinding machine

Cutterheads Bottom Blade Replacement

1. Remove the bottom blade holder by removing the 3 fixing bolts at each end and withdraw from the cutterheads.
2. Remove the worn bottom blade and discard the countersunk screws and securing nuts.
3. Fit the new blade to the holder and loosely assemble with new countersunk screws and securing nuts.
4. Tighten the centre bolts to a torque of 40 N-m (30 lb-ft).
5. Continue by tightening the remaining bolts to the same torque by working from the centre out towards the blade ends.
6. The new bottom blade must be ground on its holder prior to refitting to the cutterheads. Adjust the cutting cylinder position to give adequate clearance for fitting the new bottom blade holder.
7. Install the bottom blade holder assembly to the cutterheads using the original fixing bolts and tighten to a torque of 35 N-m (26 lb-ft).
8. Finally adjust the cylinder to the bottom blade.

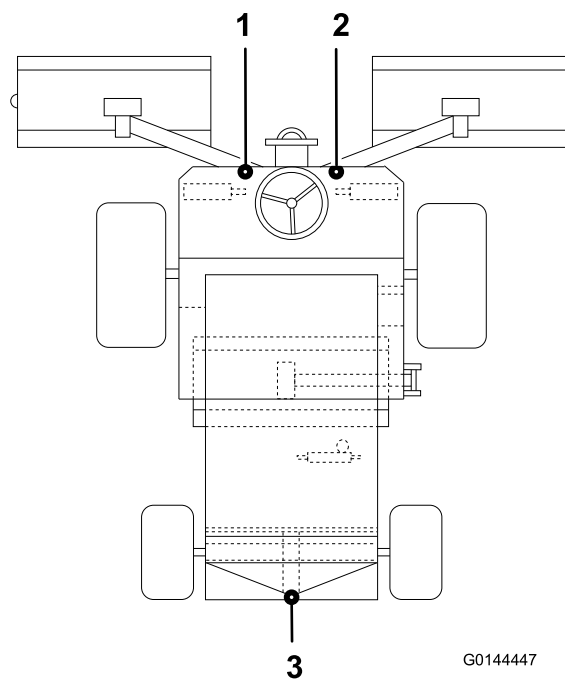

Figure 75

G0144447

1. Front left hand lifting point
2. Front right hand lifting point
3. Rear lifting point

Raising The Mower Off The Ground

▲ WARNING

When the mower is raised off the ground:

- NEVER crawl under the mower.
- NEVER start the engine.

Important: Before raising the mower ensure that the lifting device to be used is in good condition and capable of supporting the weight of the mower securely. Minimum lift capacity 2000 Kg (2 Tons).

1. Park the mower on level ground.
2. Set the parking brake.
3. Turn the engine switch to off and remove the ignition key.
4. Ensure the ground under the lifting device is level and firm.
5. Align and ensure the lifting device is secure against one of the mowers lifting points.
6. If raising the front of the mower, chock the rear wheels to prevent the mower rolling away.

Note: The parking brake only operates on the front wheels.

Waste Disposal

Engine oil, batteries, hydraulic oil, and engine coolant are pollutants to the environment. Dispose of these according to your local regulations.

When disposing of hazardous waste products, take them to an authorized disposal site. Waste products must not be allowed to contaminate surface water, drains or sewage systems.

⚠ CAUTION

Dispose of hazardous substances correctly.

- **Do not dispose of batteries with a separate collection mark into general waste.**
- **When disposing of hazardous waste products, take them to an authorized disposal site.**

Storage

Preparing the Traction Unit

1. Thoroughly clean the traction unit, cutting units, and engine.
2. Check the tyre pressure. Refer to Checking the Tyre Pressure in the Setup Section.
3. Check all fasteners for looseness and tighten them as necessary.
4. Grease all grease fittings and pivot points. Wipe up any excess lubricant.
5. Lightly sand and use touch-up paint on painted areas that are scratched, chipped, or rusted. Repair any dents in the metal body.
6. Service the battery and cables as follows:
 - A. Remove the battery terminals from the battery posts.
 - B. Clean the battery, terminals, and posts with a wire brush and baking soda solution.
 - C. Coat the cable terminals and battery posts with Grafo 112X skin-over grease (Toro Part No. 505-47) or petroleum jelly to prevent corrosion.
 - D. Slowly recharge the battery every 60 days for 24 hours to prevent lead sulfation of the battery.

Preparing the Engine

1. Drain the engine oil from the oil pan and replace the drain plug.
2. Remove and discard the oil filter. Install a new oil filter.
3. Refill the oil pan with designated quantity of motor oil.
4. Start the engine and run it at idle speed for approximately two minutes.
5. Stop the engine.
6. Thoroughly drain all fuel from the fuel tank, lines, and the fuel filter/water separator assembly.
7. Flush the fuel tank with fresh, clean diesel fuel.
8. Secure all fuel system fittings.
9. Thoroughly clean and service the air cleaner assembly.
10. Seal the air cleaner inlet and the exhaust outlet with weatherproof tape.
11. Check the antifreeze protection and add as needed for expected minimum temperature in your area.

Troubleshooting

Problem	Possible Cause	Corrective Action
Areas of uncut grass at overlap between cutting cylinders	<ol style="list-style-type: none"> 1. Turning too tightly 2. Mower sliding sideways when travelling across face of slope 3. No ground contact on one end of the cutter because poorly routed hoses or wrongly positioned hydraulic adaptors 4. No ground contact on one end of the cutter because pivot pins seizing 5. No ground contact on one end of the cutter because of grass build up under cutterhead 	<ol style="list-style-type: none"> 1. Reduce turning radius 2. Mow up/down slope 3. Correct hose routing/reposition hydraulic adaptors 4. Release and grease pivot points 5. Remove grass
Ridge lines in the cut across the direction of travel over full width	<ol style="list-style-type: none"> 1. Forward speed too high 2. Cylinder speed too slow 3. Height of cut too low 	<ol style="list-style-type: none"> 1. Reduce forward speed 2. Increase mower engine speed 3. Raise height of cut
Ridge lines in the cut grass across the direction of travel over cutting width of one cylinder	<ol style="list-style-type: none"> 1. Cylinder is running slow 	<ol style="list-style-type: none"> 1. Refer to TROUBLE SHOOTING
Step in cut grass height at point of overlap between cutting cylinders	<ol style="list-style-type: none"> 1. Inconsistent height of cut setting on one cylinder 2. Raise/lower position control not in float position 3. No ground contact on one end of the cutter because poorly routed hoses or wrongly positioned hydraulic adaptors 4. No ground contact on one end of the cutter because pivot pins seizing 5. No ground contact on one end of the cutter because of grass build up under cutterhead 	<ol style="list-style-type: none"> 1. Check and readjust height of cut setting 2. Operate position control to float position 3. Correct hose routing/reposition hydraulic adaptors 4. Release and grease pivot points 5. Remove grass
Some uncut or poorly cut strands of grass	<ol style="list-style-type: none"> 1. Cutting cylinder is partially out of contact with the bottom blade 2. Cutting cylinder is in heavy contact with the bottom blade 3. Height of cut is too high 4. Cutting edges of cutting cylinders/bottom blades are rounded 	<ol style="list-style-type: none"> 1. Readjust cutting cylinder to bottom blade 2. Readjust cutting cylinder to the bottom blade 3. Lower height of cut setting 4. Back lap or regrind to restore cutting edges
Lines of uncut or badly cut grass in direction of travel	<ol style="list-style-type: none"> 1. Tram lining of cutting edges due to heavy contact caused by poor cutting cylinder to bottom blade adjustment 2. Bottom blade in ground contact 3. Nose down attitude of bottom blade 4. Cutterheads bouncing 5. Worn cylinder bearings/bearing housing pivots 6. Loose components in cutterhead 	<ol style="list-style-type: none"> 1. Back lap or regrind to restore cutting edges 2. Raise height of cut 3. Re adjust cutterhead to ensure bottom blade is parallel to ground 4. Reduce forward speed and reduce weight transfer 5. Replace worn parts 6. Check and retighten as necessary
Scalping	<ol style="list-style-type: none"> 1. Undulations too severe for height of cut setting 2. Height of cut too low 	<ol style="list-style-type: none"> 1. Use floating cutterheads 2. Raise height of cut

Problem	Possible Cause	Corrective Action
Excessive bottom blade wear	<ol style="list-style-type: none"> 1. Bottom blade in heavy ground contact 2. Cutting edges of the cutting cylinder/ bottom blade are rounded 3. Cylinder is in heavy contact with the bottom blade 4. Damaged cutting cylinder or bottom blade 5. Excessively abrasive ground conditions 	<ol style="list-style-type: none"> 1. Raise height of cut 2. Back lap or regrind to restore cutting edges 3. Adjust the cutting cylinder to the bottom blade 4. Grind or replace as necessary 5. Raise height of cut
Engine will not start with ignition key	<ol style="list-style-type: none"> 1. Transmission neutral interlock switch not energized 2. Parking brake interlock switch not energized 3. Cutterhead drive interlock switch not energized 4. Faulty electrical connection 	<ol style="list-style-type: none"> 1. Remove foot from forward/reverse pedals or Check setting of transmission neutral interlock switch 2. Operate parking brake switch to the ON position 3. Check setting of parking brake interlock switch 4. Trace and correct fault
Flat battery	<ol style="list-style-type: none"> 1. Terminal connection loose or corroded 2. Loose or defective alternator belt 3. Defective battery 4. Electrical short circuit 	<ol style="list-style-type: none"> 1. Clean and tighten terminal connections. Recharge battery 2. Adjust tension or replace drive belt, refer to ENGINE HANDBOOK 3. Charge battery or replace battery 4. Trace short circuit and fix
Hydraulic oil system overheating	<ol style="list-style-type: none"> 1. Blocked screen 2. Blocked oil cooler fins 3. Blocked engine radiator matrix 4. Low relief valve setting 5. Low oil level 6. Brakes engaged 7. Cutting cylinders tight on bottom 8. Defective fan or fan drive 	<ol style="list-style-type: none"> 1. Clean screen 2. Clean fins 3. Clean matrix 4. Have relief valve pressure checked. Consult your authorized dealer 5. Fill reservoir to correct level 6. Disengage brakes 7. Adjust settings 8. Check fan operation and service as required
Incorrect brake operation	<ol style="list-style-type: none"> 1. Faulty wheel motor brake assembly 2. Worn brake discs 	<ol style="list-style-type: none"> 1. Consult your authorised dealer 2. Replace brake discs Consult your authorised dealer
Lack of steering	<ol style="list-style-type: none"> 1. Defective steering valve 2. Defective hydraulic cylinder 3. Damaged steering hose 	<ol style="list-style-type: none"> 1. Service or replace steering valve 2. Service or replace hydraulic cylinder 3. Replace defective hose
No machine movement forward or reverse	<ol style="list-style-type: none"> 1. Parking brake engaged 2. Low oil level 3. Incorrect oil used 4. Damaged drive pedal linkage 5. Damaged transmission pump 6. Transmission bypass valve open 7. Broken drive coupling 	<ol style="list-style-type: none"> 1. Release parking brake 2. Fill reservoir to correct level 3. Drain reservoir and refill with correct oil 4. Check linkage and replace defective parts 5. Have the transmission pump overhauled by your authorized dealer 6. Close bypass valve 7. Replace drive coupling
Forward/backward transmission creep in neutral	<ol style="list-style-type: none"> 1. Transmission neutral adjustment incorrectly set 	<ol style="list-style-type: none"> 1. Adjust transmission neutral linkage setting

Problem	Possible Cause	Corrective Action
Excessive noise in hydraulic system	<ol style="list-style-type: none"> 1. Faulty pump 2. Faulty motor 3. Air leaking into system 4. Suction strainer blocked or damaged 5. Excessive oil viscosity due to cold conditions 6. Low relief valve setting 7. Low hydraulic oil level 	<ol style="list-style-type: none"> 1. Identify noisy pump and service or replace 2. Identify noisy motor and service or replace 3. Tighten or replace hydraulic fittings particularly in suction lines 4. Clean and replace suction strainer or renew as necessary 5. Allow system to warm up 6. Have relief valve pressure checked. Consult your authorized dealer 7. Fill hydraulic oil reservoir to correct level
After initial satisfactory operation machine loses power	<ol style="list-style-type: none"> 1. Worn pump or motor 2. Low hydraulic oil level 3. Incorrect oil viscosity 4. Oil filter element blocked 5. Faulty pressure relief valve 6. Overheating 7. Leaks on suction hose 	<ol style="list-style-type: none"> 1. Replace as necessary 2. Fill hydraulic oil tank to correct level 3. Renew oil in hydraulic tank with correct viscosity grade oil, refer to SPECIFICATIONS 4. Change filter element 5. Have relief valve cleaned and pressure checked. Consult your authorised dealer 6. Check cylinder to bottom blade adjustment. Reduce work rate i.e. increase height of cut or reduce forward speed 7. Check and tighten fittings. Replace hose if necessary.
Cylinder 'knocks' while rotating	<ol style="list-style-type: none"> 1. High spot on cylinder or bottom blade due to contact with foreign object 2. Worn cylinder bearings 	<ol style="list-style-type: none"> 1. Remove high spot with a stone and back lap to restore cutting edges. Serious damage will require re grinding 2. Replace as necessary
One cylinder rotates slowly	<ol style="list-style-type: none"> 1. Cutting cylinder bearing seized 2. Incorrect rotation motor fitted 3. Motor integral check valve jammed open 4. Cutting cylinder tight on the bottom blade 5. Motor worn 	<ol style="list-style-type: none"> 1. Replace as necessary 2. Check motor and replace if necessary 3. Have check valve cleaned and checked 4. Re adjust setting 5. Replace motor
Cutterhead fails to lift out of work	<ol style="list-style-type: none"> 1. Lift cylinder seal failure 2. Pressure relief valve jammed open or wrongly set 3. Defective control valve 4. Mechanical blockage 	<ol style="list-style-type: none"> 1. Replace seals 2. Have relief valve pressure checked. Consult your authorized dealer 3. Overhaul control valve 4. Remove blockage
Cutterheads do not follow ground contours	<ol style="list-style-type: none"> 1. Incorrect hose routing or incorrect orientation of hydraulic fittings 2. Tightness in pivots 3. Mower operated in 'hold' position 4. Weight transfer set too high 	<ol style="list-style-type: none"> 1. Move cutterheads throughout extremes of movement and observe any tightness in the hoses. Correctly route hoses and orientate fittings as necessary 2. Release and grease as necessary 3. Move position control switch to 'down / float' position 4. Reduce weight transfer

Problem	Possible Cause	Corrective Action
Cutterheads fail to start up when lowered into work	<ol style="list-style-type: none"> 1. Faulty seat sensor switch 2. Low oil level 3. Sheared drive shaft 4. Pressure relief valve jammed open or wrongly set 5. Cutting cylinder jammed 6. Cutting cylinder tight on bottom blade 7. Cutterhead control valve in the 'off' position caused by defective control valve 8. Cutterhead control valve in the 'off' position caused by electrical fault 9. Lift arm proximity switch incorrectly set 	<ol style="list-style-type: none"> 1. Check mechanical and electrical operation of switch 2. Fill hydraulic oil reservoir to correct level 3. Check motor and cylinder drive shafts and replace if necessary 4. Have relief valve pressure checked. Consult your authorized dealer 5. Clear as necessary 6. Re adjust setting 7. Overhaul control valve 8. Electrical fault Have electrical system checked 9. Check and adjust proximity switch.
Cylinders rotate in wrong direction	<ol style="list-style-type: none"> 1. Hoses wrongly connected 2. Cutterhead drive switch wrongly connected 	<ol style="list-style-type: none"> 1. Check hydraulic circuit and re connect as necessary 2. Check switch electrical connections

Schematics

LT3340 ELECTRICAL CIRCUIT DIAGRAM

Wiring Harness 111-6461
Loom Kit 111-6920

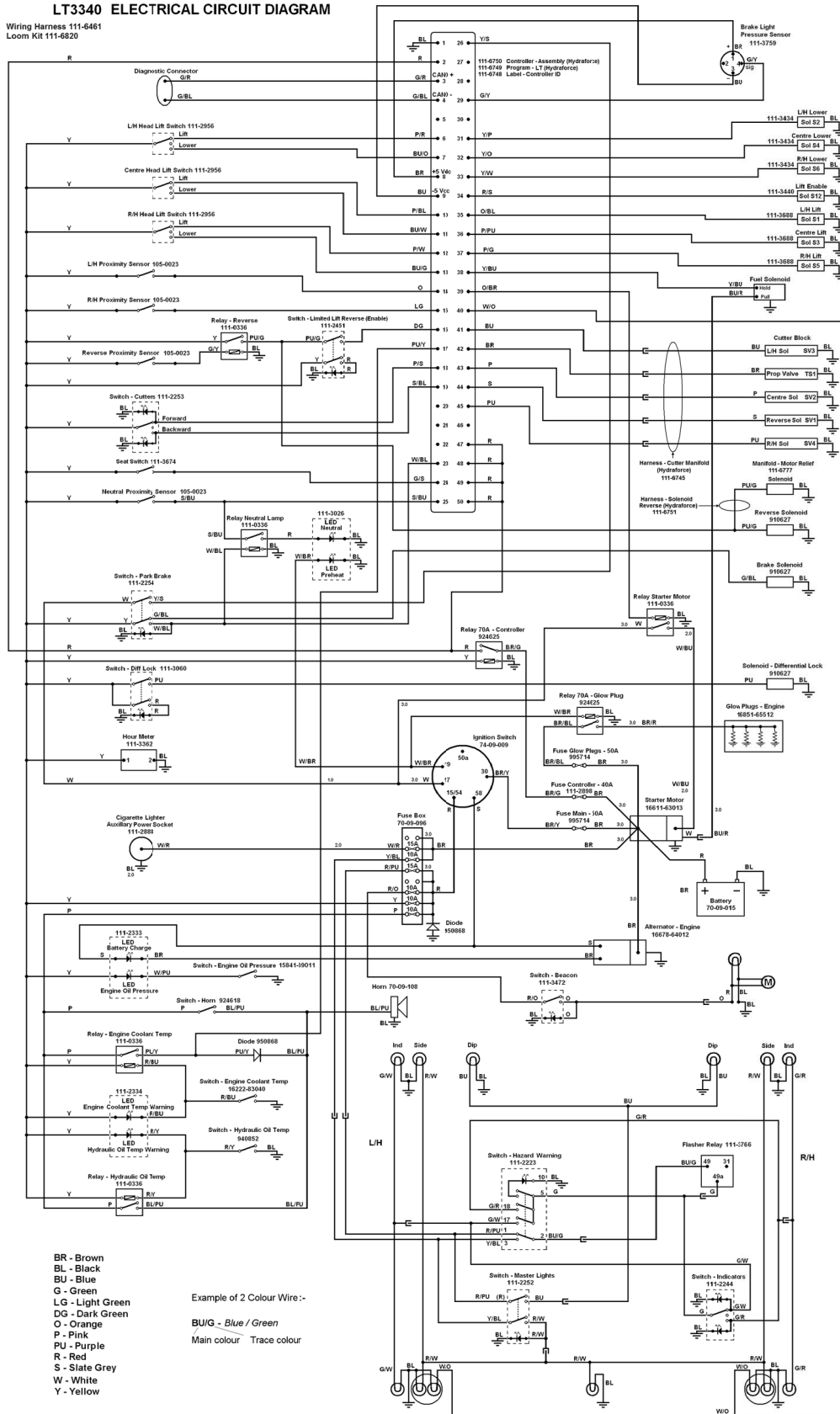

G022305

Electrical Schematic (Rev. A)

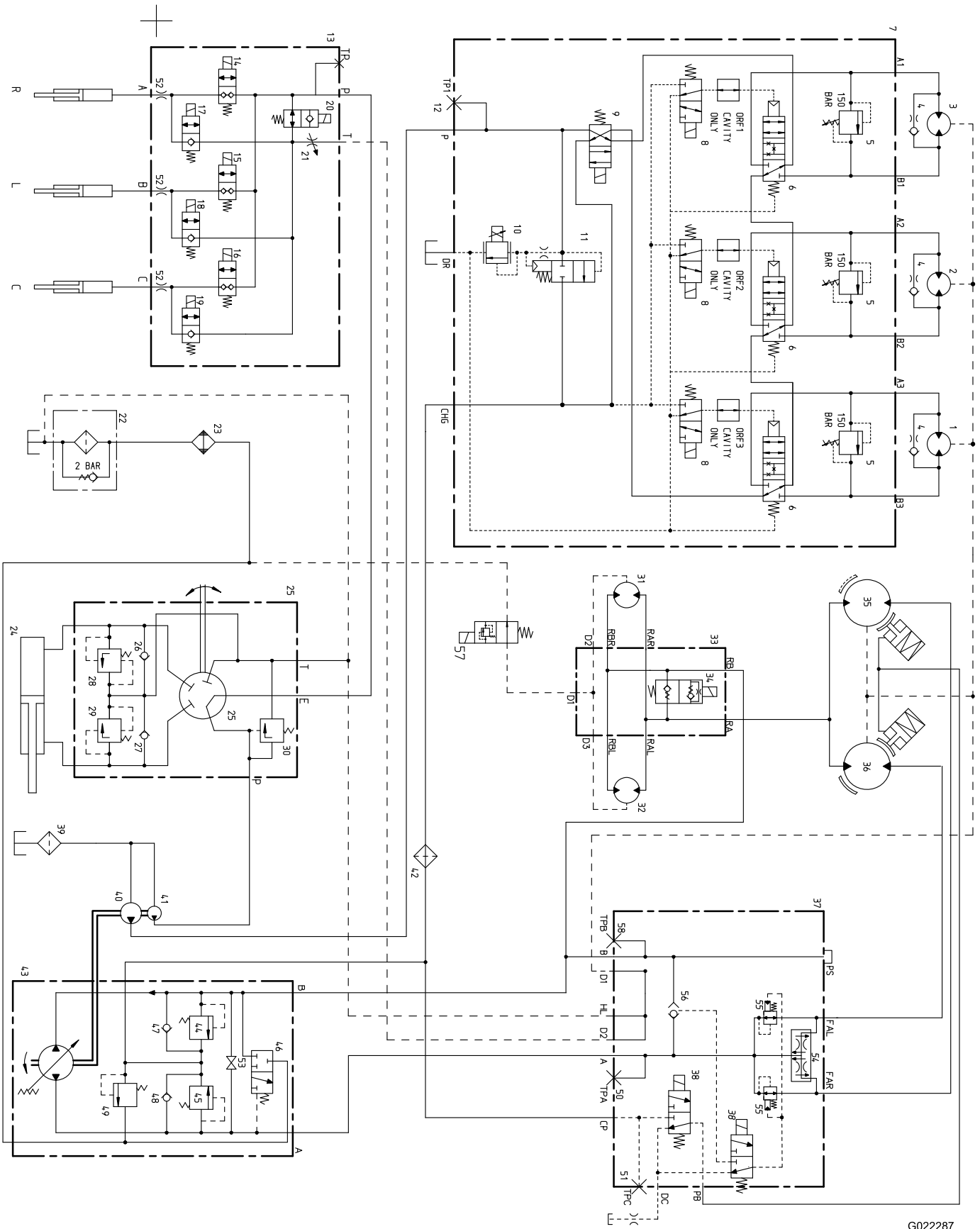

G022287

Item number	Description	Part Number
1	HYDRAULIC MOTOR - LH FRONT CUTTERHEAD	940602
2	HYDRAULIC MOTOR - CTR FRONT CUTTERHEAD	910696
3	HYDRAULIC MOTOR - RH CUTTERHEAD	910696
4	CHECK VALVE / ORIFICE - MOTOR BYPASS	-
5	RELIEF VALVE. INDIVIDUAL MOTOR PROTECTION	111-6833
6	PILOT SPOOL VALVE, CUTTER ENGAGE	111-6829
7	CUTTER CONTROL MANIFOLD	111-6595
8	12V SOLENOID VALVE, CUTTER ENGAGE	125-7554
9	12V SOLENOID VALVE, CUTTER FWD/REVERSE CONTROL	111-6835
10	12V PROPORTIONAL RELIEF VALVE. MAIN	111-6825
11	LOGIC ELEMENT. FLOW CONTROL DEVICE	111-6832
12	TEST PORT-MAIN CUTTER PRESSURE	910615
13	LIFT CONTROL MANIFOLD	111-3435
14	SOLENOID VALVE - LIFT RH FRONT ARM	111-3436
15	SOLENOID VALVE - LIFT LH FRONT ARM	111-3436
16	SOLENOID VALVE - LIFT CENTRE ARM	111-3436
17	SOLENOID VALVE - LOWER RH FRONT ARM	111-3437
18	SOLENOID VALVE - LOWER LH FRONT ARM	111-3437
19	SOLENOID VALVE - LOWER CENTRE ARM	111-3437
20	SOLENOID VALVE LIFT ACTIVATION	111-3438
21	WEIGHT TRANSFER VALVE	111-3439
22	RETURN FILTER	924865
23	OIL COOLER	70-06-171
24	STEERING CYLINDER	111-1956
25	STEERING UNIT	111-2574
26	CHECK VALVE STEERING SHOCK BYPASS LH	-
27	CHECK VALVE STEERING SHOCK BYPASS RH	-
28	RELIEF VALVE 183 BAR STEERING SHOCK BYPASS LH	-
29	RELIEF VALVE 183 BAR STEERING SHOCK BYPASS RH	-
30	PRESSURE RELIEF VALVE 115 BAR	-
31	HYDRAULIC MOTOR - LH REAR WHEEL	111-2260
32	HYDRAULIC MOTOR - RH REAR WHEEL	111-2260

33	REAR TRANSMISSION MANIFOLD	924687
34	SOLENOID VALVE - FWD REVERSE CHECK VALVE 4WD	924688
35	HYDRAULIC MOTOR - LH FRONT WHEEL	111-2557
36	HYDRAULIC MOTOR - RH FRONT WHEEL	111-2557
37	FRONT TRANSMISSION MANIFOLD	111-3993
38	SOLENOID VALVE - PARKING BRAKE/DIFF LOCK	111-3533
39	SUCTION STRAINER	65-06-305
40	GEAR PUMP - CUTTERHEAD DRIVE	111-3553
41	GEAR PUMP - LIFT & STEER	111-3553
42	PRESSURE FILTER	924708
43	TRANSMISSION PUMP	111-6774
44	PRESSURE RELIEF VALVE REVERSE TRAVEL 300 BAR	111-6775
45	PRESSURE RELIEF VALVE FORWARD TRAVEL 345 BAR	111-3379
46	PURGE VALVE	-
47	CHECK VALVE TRANSMISSION REVERSE BYPASS	-
48	CHECK VALVE TRANSMISSION FORWARD BYPASS	-
49	PRESSURE RELIEF VALVE - CHARGE PRESSURE BAR	111-3378
50	TEST PORT - TRANSMISSION PRESSURE - FORWARD	910615
51	TEST PORT - CHARGE PRESSURE	910615
52	ORIFICE PLATE - 2 WAY	111-3689
53	TRANSMISSION BYPASS VALVE	-
54	VALVE DIFFERENTIAL LOCK	111-4466
55	VALVE DIVERTER	111-4467
56	SHUTTLE VALVE	910629
57	SOLENOID VALVE RELIEF 100 BAR	111-6777
58	SHUTTLE VALVE	910615

Hydraulic Schematic (Rev. A)

International Distributor List

Distributor:	Country:	Phone Number:	Distributor:	Country:	Phone Number:
Atlantis Su ve Sulama Sisstemleri Lt	Turkey	90 216 344 86 74	Maquiver S.A.	Colombia	57 1 236 4079
Balama Prima Engineering Equip.	Hong Kong	852 2155 2163	Maruyama Mfg. Co. Inc.	Japan	81 3 3252 2285
B-Ray Corporation	Korea	82 32 551 2076	Agrolanc Kft	Hungary	36 27 539 640
Casco Sales Company	Puerto Rico	787 788 8383	Mountfield a.s.	Czech Republic	420 255 704 220
Ceres S.A.	Costa Rica	506 239 1138	Munditol S.A.	Argentina	54 11 4 821 9999
CSSC Turf Equipment (pvt) Ltd.	Sri Lanka	94 11 2746100	Oslinger Turf Equipment SA	Ecuador	593 4 239 6970
Cyril Johnston & Co.	Northern Ireland	44 2890 813 121	Oy Hako Ground and Garden Ab	Finland	358 987 00733
Equiver	Mexico	52 55 539 95444	Parkland Products Ltd.	New Zealand	64 3 34 93760
Femco S.A.	Guatemala	502 442 3277	Prato Verde S.p.A.	Italy	39 049 9128 128
G.Y.K. Company Ltd.	Japan	81 726 325 861	Prochaska & Cie	Austria	43 1 278 5100
Geomechaniki of Athens	Greece	30 10 935 0054	RT Cohen 2004 Ltd.	Israel	972 986 17979
Guandong Golden Star	China	86 20 876 51338	Riversa	Spain	34 9 52 83 7500
Hako Ground and Garden	Sweden	46 35 10 0000	Sc Svend Carlsen A/S	Denmark	45 66 109 200
Hako Ground and Garden	Norway	47 22 90 7760	Solvert S.A.S.	France	33 1 30 81 77 00
Hayter Limited (U.K.)	United Kingdom	44 1279 723 444	Spypros Stavrinides Limited	Cyprus	357 22 434131
Hydroturf Int. Co Dubai	United Arab Emirates	97 14 347 9479	Surge Systems India Limited	India	91 1 292299901
Hydroturf Egypt LLC	Egypt	202 519 4308	T-Markt Logistics Ltd.	Hungary	36 26 525 500
Irriamc	Portugal	351 21 238 8260	Toro Australia	Australia	61 3 9580 7355
Irrigation Products Int'l Pvt Ltd.	India	0091 44 2449 4387	Toro Europe NV	Belgium	32 14 562 960
Jean Heybroek b.v.	Netherlands	31 30 639 4611			

European Privacy Notice

The Information Toro Collects

Toro Warranty Company (Toro) respects your privacy. In order to process your warranty claim and contact you in the event of a product recall, we ask you to share certain personal information with us, either directly or through your local Toro company or dealer.

The Toro warranty system is hosted on servers located within the United States where privacy law may not provide the same protection as applies in your country.

BY SHARING YOUR PERSONAL INFORMATION WITH US, YOU ARE CONSENTING TO THE PROCESSING OF YOUR PERSONAL INFORMATION AS DESCRIBED IN THIS PRIVACY NOTICE.

The Way Toro Uses Information

Toro may use your personal information to process warranty claims, to contact you in the event of a product recall and for any other purpose which we tell you about. Toro may share your information with Toro's affiliates, dealers or other business partners in connection with any of these activities. We will not sell your personal information to any other company. We reserve the right to disclose personal information in order to comply with applicable laws and with requests by the appropriate authorities, to operate our systems properly or for our own protection or that of other users.

Retention of your Personal Information

We will keep your personal information as long as we need it for the purposes for which it was originally collected or for other legitimate purposes (such as regulatory compliance), or as required by applicable law.

Toro's Commitment to Security of Your Personal Information

We take reasonable precautions in order to protect the security of your personal information. We also take steps to maintain the accuracy and current status of personal information.

Access and Correction of your Personal Information

If you would like to review or correct your personal information, please contact us by email at legal@toro.com.

Australian Consumer Law

Australian customers will find details relating to the Australian Consumer Law either inside the box or at your local Toro Dealer.



The Toro Total Coverage Guarantee

A Limited Warranty

Conditions and Products Covered

The Toro® Company and its affiliate, Toro Warranty Company, pursuant to an agreement between them, jointly warrant your Toro Commercial product ("Product") to be free from defects in materials or workmanship for two years or 1500 operational hours*, whichever occurs first. This warranty is applicable to all products with the exception of Aerators (refer to separate warranty statements for these products). Where a warrantable condition exists, we will repair the Product at no cost to you including diagnostics, labor, parts, and transportation. This warranty begins on the date the Product is delivered to the original retail purchaser.

* Product equipped with an hour meter.

Instructions for Obtaining Warranty Service

You are responsible for notifying the Commercial Products Distributor or Authorized Commercial Products Dealer from whom you purchased the Product as soon as you believe a warrantable condition exists. If you need help locating a Commercial Products Distributor or Authorized Dealer, or if you have questions regarding your warranty rights or responsibilities, you may contact us at:

Commercial Products Service Department
Toro Warranty Company
8111 Lyndale Avenue South
Bloomington, MN 55420-1196
E-mail: commercial.warranty@toro.com

Owner Responsibilities

As the Product owner, you are responsible for required maintenance and adjustments stated in your Operator's Manual. Failure to perform required maintenance and adjustments can be grounds for disallowing a warranty claim.

Items and Conditions Not Covered

Not all product failures or malfunctions that occur during the warranty period are defects in materials or workmanship. This warranty does not cover the following:

- Product failures which result from the use of non-Toro replacement parts, or from installation and use of add-on, or modified non-Toro branded accessories and products. A separate warranty may be provided by the manufacturer of these items.
- Product failures which result from failure to perform recommended maintenance and/or adjustments. Failure to properly maintain your Toro product per the Recommended Maintenance listed in the *Operator's Manual* can result in claims for warranty being denied.
- Product failures which result from operating the Product in an abusive, negligent or reckless manner.
- Parts subject to consumption through use unless found to be defective. Examples of parts which are consumed, or used up, during normal Product operation include, but are not limited to, brakes pads and linings, clutch linings, blades, reels, bed knives, tines, spark plugs, castor wheels, tires, filters, belts, and certain sprayer components such as diaphragms, nozzles, and check valves, etc.
- Failures caused by outside influence. Items considered to be outside influence include, but are not limited to, weather, storage practices,

contamination, use of unapproved coolants, lubricants, additives, fertilizers, water, or chemicals, etc.

- Normal noise, vibration, wear and tear, and deterioration.
- Normal "wear and tear" includes, but is not limited to, damage to seats due to wear or abrasion, worn painted surfaces, scratched decals or windows, etc.

Parts

Parts scheduled for replacement as required maintenance are warranted for the period of time up to the scheduled replacement time for that part. Parts replaced under this warranty are covered for the duration of the original product warranty and become the property of Toro. Toro will make the final decision whether to repair any existing part or assembly or replace it. Toro may use remanufactured parts for warranty repairs.

Note Regarding Deep Cycle Battery Warranty:

Deep cycle batteries have a specified total number of kilowatt-hours they can deliver during their lifetime. Operating, recharging, and maintenance techniques can extend or reduce total battery life. As the batteries in this product are consumed, the amount of useful work between charging intervals will slowly decrease until the battery is completely worn out. Replacement of worn out batteries, due to normal consumption, is the responsibility of the product owner. Battery replacement may be required during the normal product warranty period at owner's expense.

Maintenance is at Owner's Expense

Engine tune-up, lubrication cleaning and polishing, replacement of Items and Conditions Not Covered filters, coolant, and completing Recommended Maintenance are some of the normal services Toro products require that are at the owner's expense.

General Conditions

Repair by an Authorized Toro Distributor or Dealer is your sole remedy under this warranty.

Neither The Toro Company nor Toro Warranty Company is liable for indirect, incidental or consequential damages in connection with the use of the Toro Products covered by this warranty, including any cost or expense of providing substitute equipment or service during reasonable periods of malfunction or non-use pending completion of repairs under this warranty. Except for the Emissions warranty referenced below, if applicable, there is no other express warranty.

All implied warranties of merchantability and fitness for use are limited to the duration of this express warranty. Some states do not allow exclusions of incidental or consequential damages, or limitations on how long an implied warranty lasts, so the above exclusions and limitations may not apply to you.

This warranty gives you specific legal rights, and you may also have other rights which vary from state to state.

Countries Other than the United States or Canada

Customers should contact their Toro Distributor (Dealer) to obtain guarantee policies for your country, province, or state. If for any reason you are dissatisfied with your Distributor's service or have difficulty obtaining guarantee information, contact the Toro importer. If all other remedies fail, you may contact us at Toro Warranty Company.