



**Count on it.**

**Parts Catalog**

**SGR-6 Stump Grinder**

Model No. 22600—Serial No. 314000001 and Up



# Ordering Replacement Parts

To order replacement parts, please supply the part number, the quantity, and the description of each part desired.

## Understanding Reference Numbers

Each identified part in an illustration has a reference number. The reference number for a part also appears in the parts list, along with other information about the part.

This catalog uses two special reference number formats, one to indicate parts in a service assembly and another to indicate the quantity of a given part in an illustration.

## Service Assembly Reference Numbers

Parts in service assemblies have reference numbers in the form a:b. The a represents the reference number of the entire service assembly and the b represents a sequential number unique to each part within the service assembly.

For example, a wheel assembly might be identified by reference number 6, the tire by 6:1, the valve by 6:2, and the wheel by 6:3. When you order the assembly identified by reference number 6, you receive all parts identified by reference numbers 6:1, 6:2, and 6:3. However, you may also order any part individually. Reference numbers of this type appear in illustration and in parts lists.

## Reference Numbers Indicating Quantity

In an illustration, if a reference number indicates more than one part, the reference number has the form nX y. The n represents the quantity of the part, the X is the multiplication symbol, and the y represents the reference number.

For example, in an illustration, the reference number 2X 37 means that two of the parts identified by reference number 37 are indicated.

# List of Abbreviations

**AR:** as required

**ASM:** assembly

**BBC:** blade brake control

**BHTF:** button head thread forming

**CARR:** carriage

**CCW:** counter clockwise

**CW:** clockwise

**DEG:** degrees

**DPA:** Dual Point Adjustment

**ECM:** electronic control module

**EXT:** external

**FH:** flat head

**GA:** gauge

**HD:** heavy-duty

**HF:** hex flange

**HH:** hex head

**HHF:** hex head flange

**HHFTF:** hex head flange thread forming

**HJ:** hex jam

**HLH:** hex lag head

**HOC:** height-of-cut

**HP:** high pressure

**HSBH:** hex socket button head

**HSFH:** hex socket flat head

**HSH:** hex socket head

**HWH:** hex washer head

**HWHTF:** hex washer head thread forming

**HYD:** hydraulic

**LH:** left hand

**LP:** low pressure

**LPG:** Liquefied Petroleum Gas

**NI:** nylon insert

**NPTF:** national pipe thread fine

**PFH:** phillips flat head

**PPH:** phillips pan head

**PPHTF:** phillips pan head thread forming

**PRH:** phillips round head

**PTH:** phillips truss head

**PTO:** power-take-off

**RH:** right hand

**ROPS:** roll-over protection system

**RRB:** rear roller brush

**SFH:** slotted fillister head

**SHH:** slotted hex head

**SHWH:** slotted hex washer head

**SPH:** slotted pan head

**SQH:** square head

**SRH:** slotted round head

**STD:** standard

**TAP:** self tapping

**TTH:** torx truss head

# Contents

Engine and Frame Assembly .....	4
Handle Assembly .....	6
3-Tooth Grinder Wheel Assembly .....	8
Brake and Wheel Assembly .....	10
Flap Assembly .....	12
Belt Drive Assembly .....	14
Attachments and Accessories .....	16

# Engine and Frame Assembly

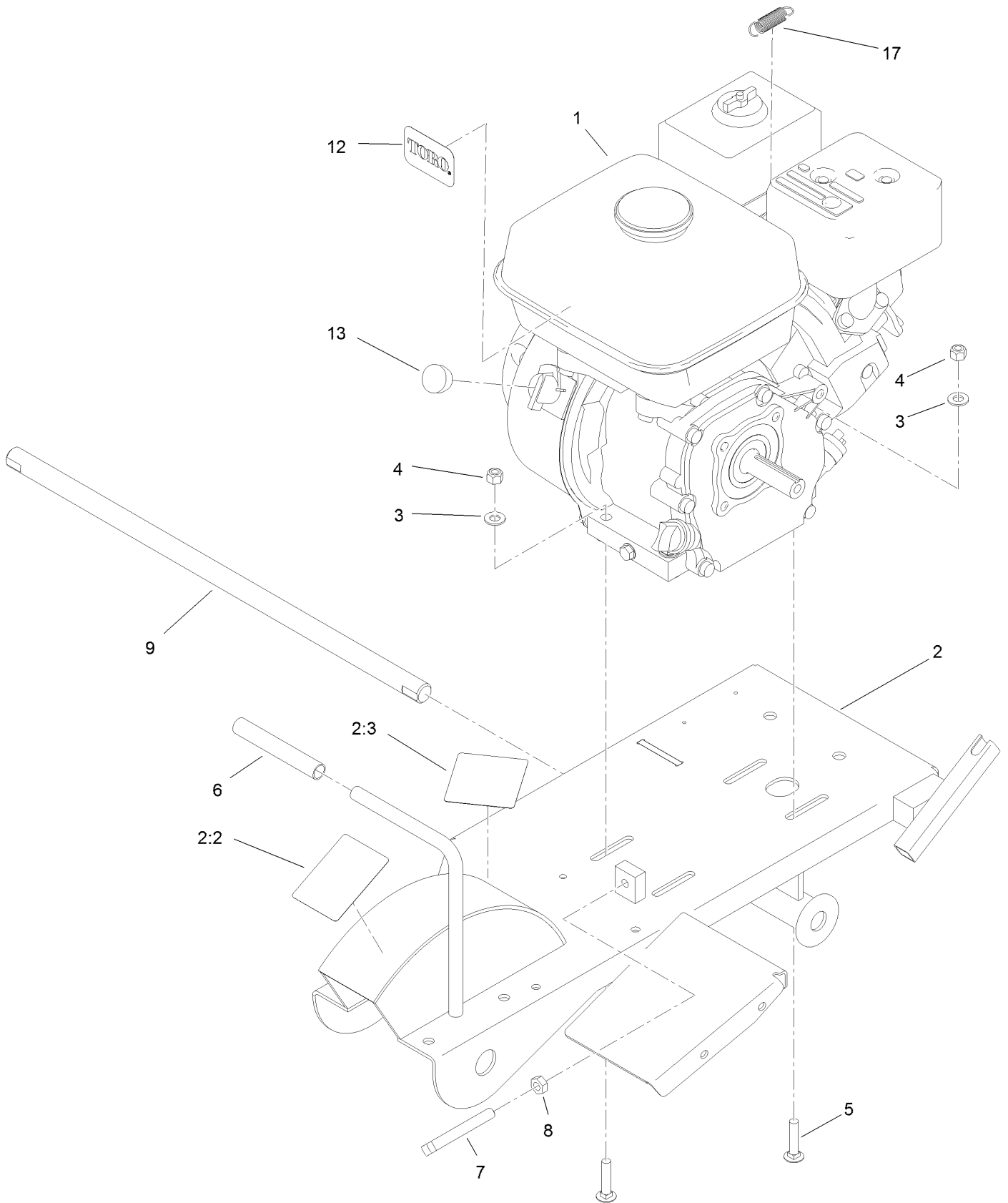

## Engine and Frame Assembly (continued)

<i>Ref.</i>	<i>Part Number</i>	<i>Qty.</i>	<i>Description</i>	<i>Ref.</i>	<i>Part Number</i>	<i>Qty.</i>	<i>Description</i>
1		1	Engine-Honda, Gx200Ut Qxc9 ●■	6	112-2605	1	Grip-Rubber
2	121-4393	1	Frame ASM	7	119-4729	1	Screw-Set, SQH
2:2	119-4690	1	Decal-Danger	8	3217-7	1	Nut-Hex
2:3	119-4693	1	Decal-Caution	9	120-1795	1	Bar-Axle, Wheel
3	3256-45	4	Washer-Flat	12	98-3206	1	Decal
4	3296-29	4	Nut-Lock, NI	13	120-1887	1	Plug-Engine
5	3230-4	4	Screw-CARR	17	119-4609	1	Spring-Extension

● Not serviced separately

■ Obtain parts from [www.honda-engines.com](http://www.honda-engines.com)

# Handle Assembly

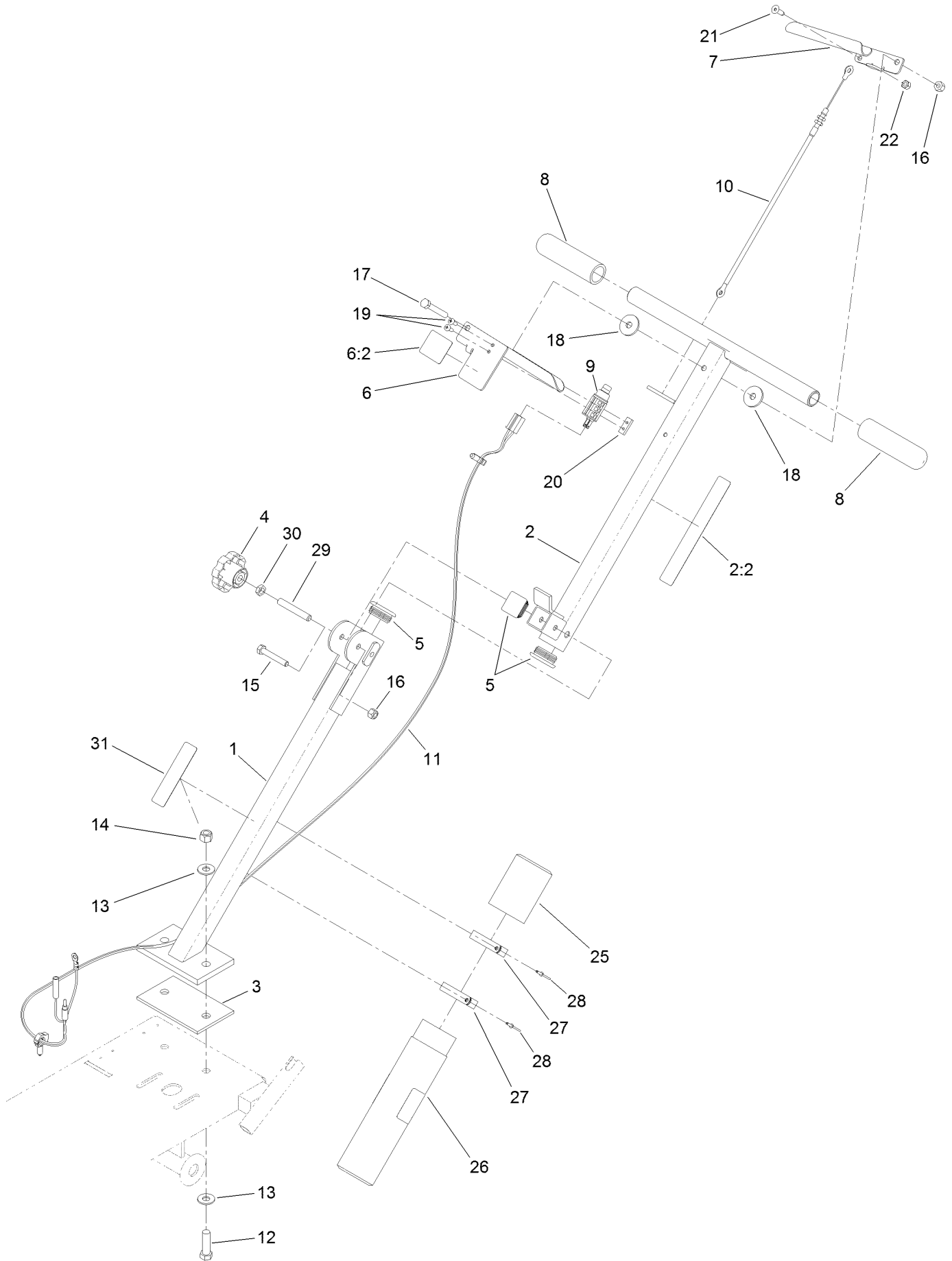

## Handle Assembly (continued)

<i>Ref.</i>	<i>Part Number</i>	<i>Qty.</i>	<i>Description</i>	<i>Ref.</i>	<i>Part Number</i>	<i>Qty.</i>	<i>Description</i>
1	120-1323-01	1	Handle-Lower	14	3296-48	2	Nut-Lock, NI
2	121-4394	1	Handle ASM	15	322-10	1	Screw-HH
2:2	119-4691	1	Decal-Caution	16	3296-29	2	Nut-Lock, NI
3	120-1324	1	Gasket-Handle	17	322-11	1	Screw-HH
4	109-1092	1	Knob	18	107675	2	Washer
5	120-1302	3	Plug-Tube	19	1-803071	2	Screw
6	121-4410	1	Plunger Handle ASM	20	1-633181	1	Plate-Tapped
6:2	119-4722	1	Decal-Engage	21	116-0606	1	Screw-Torx
7	120-1359-03	1	Handle-Throttle	22	3296-42	1	Nut-Lock, NI
8	120-1333	2	Grip-Handle	25	104-7048	1	Cap-Housing
9	120-1292	1	Switch-Plunger, Nc (W/Cover)	26	104-7050	1	Tube-Manual
10	120-1375	1	Cable-Throttle	27	2412-120	2	Clamp-R
11	120-1369	1	Harness-Wire	28	3269-17	2	Rivet-Pop
12	324-6	2	Screw-HH	29	120-0909	1	Screw-HSH
13	3256-4	4	Washer-Flat	30	3218-3	1	Nut-Jam
				31	117-2718	1	Decal-Arrester, Spark

# 3-Tooth Grinder Wheel Assembly

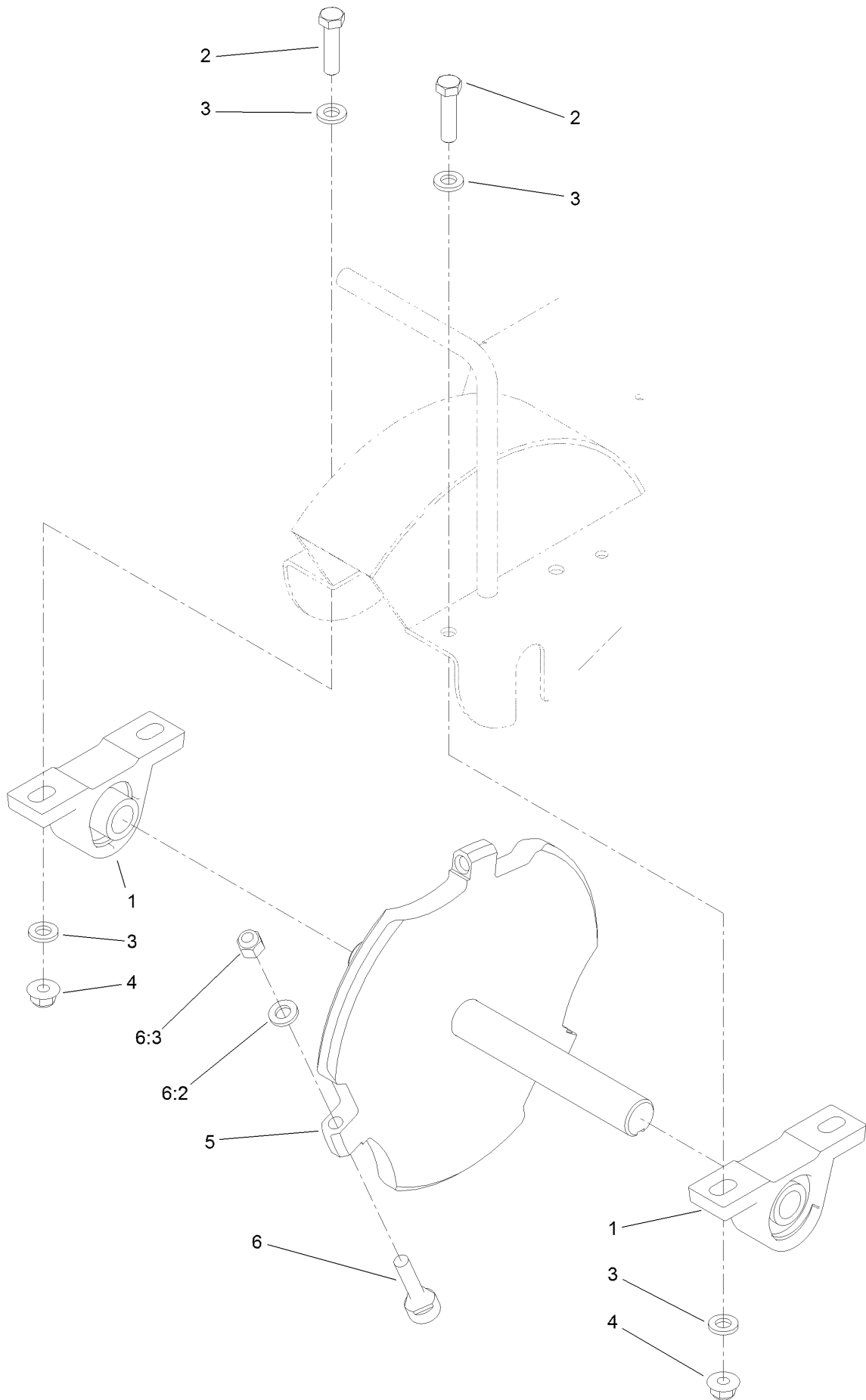



## 3-Tooth Grinder Wheel Assembly (continued)

<i>Ref.</i>	<i>Part Number</i>	<i>Qty.</i>	<i>Description</i>	<i>Ref.</i>	<i>Part Number</i>	<i>Qty.</i>	<i>Description</i>
1	120-1373	2	Bearing	5	131-2915-03	1	Wheel-Cutter
2	323-8	4	Screw-HH	6	130-2221	3	Grinder Tooth ASM
3	107-1413	8	Washer-Hardened	6:2	107-1413	1	Washer-Hardened
4	104-8301	4	Nut-Flange, NI	6:3	3296-39	1	Nut-Lock, NI

# Brake and Wheel Assembly

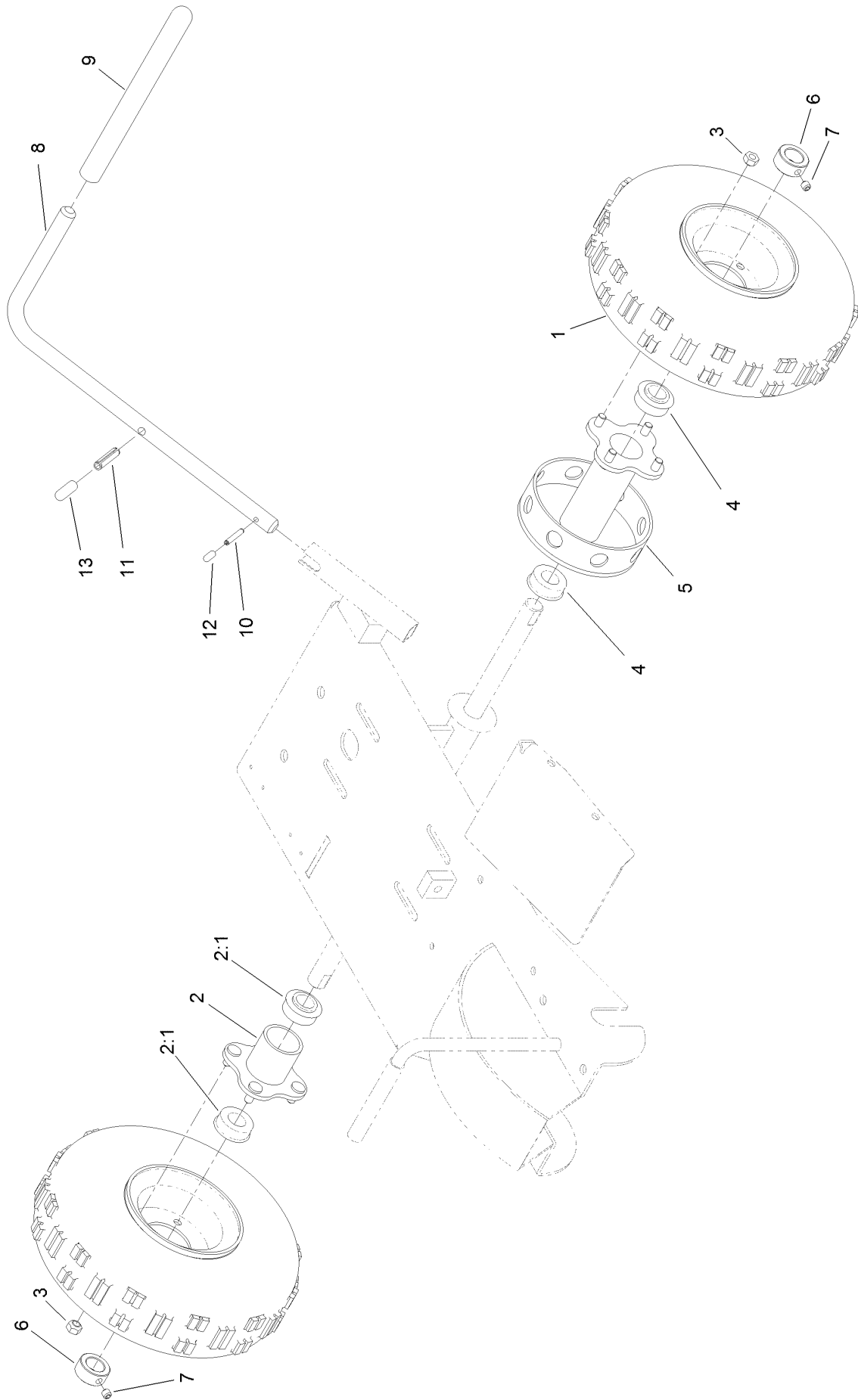

## Brake and Wheel Assembly (continued)

<i>Ref.</i>	<i>Part Number</i>	<i>Qty.</i>	<i>Description</i>	<i>Ref.</i>	<i>Part Number</i>	<i>Qty.</i>	<i>Description</i>
1	120-1288	2	Wheel And Tire ASM	7	3246-2	2	Screw-Set, HSH
2	120-1295	1	Hub	8	120-1309-01	1	Handle-Brake
2:1	120-1296	2	Bearing-Wheel	9	119-0222	1	Grip
3	120-1304	8	Nut-Wheel	10	32121-6	1	Pin-Roll, Slotted
4	120-1296	2	Bearing-Wheel	11	32121-25	1	Pin-Roll
5	120-1325-03	1	Hub-Brake	12	119-4741	1	Cap-Lower
6	120-1294	2	Collar-Set	13	119-4742	1	Cap-Upper

# Flap Assembly

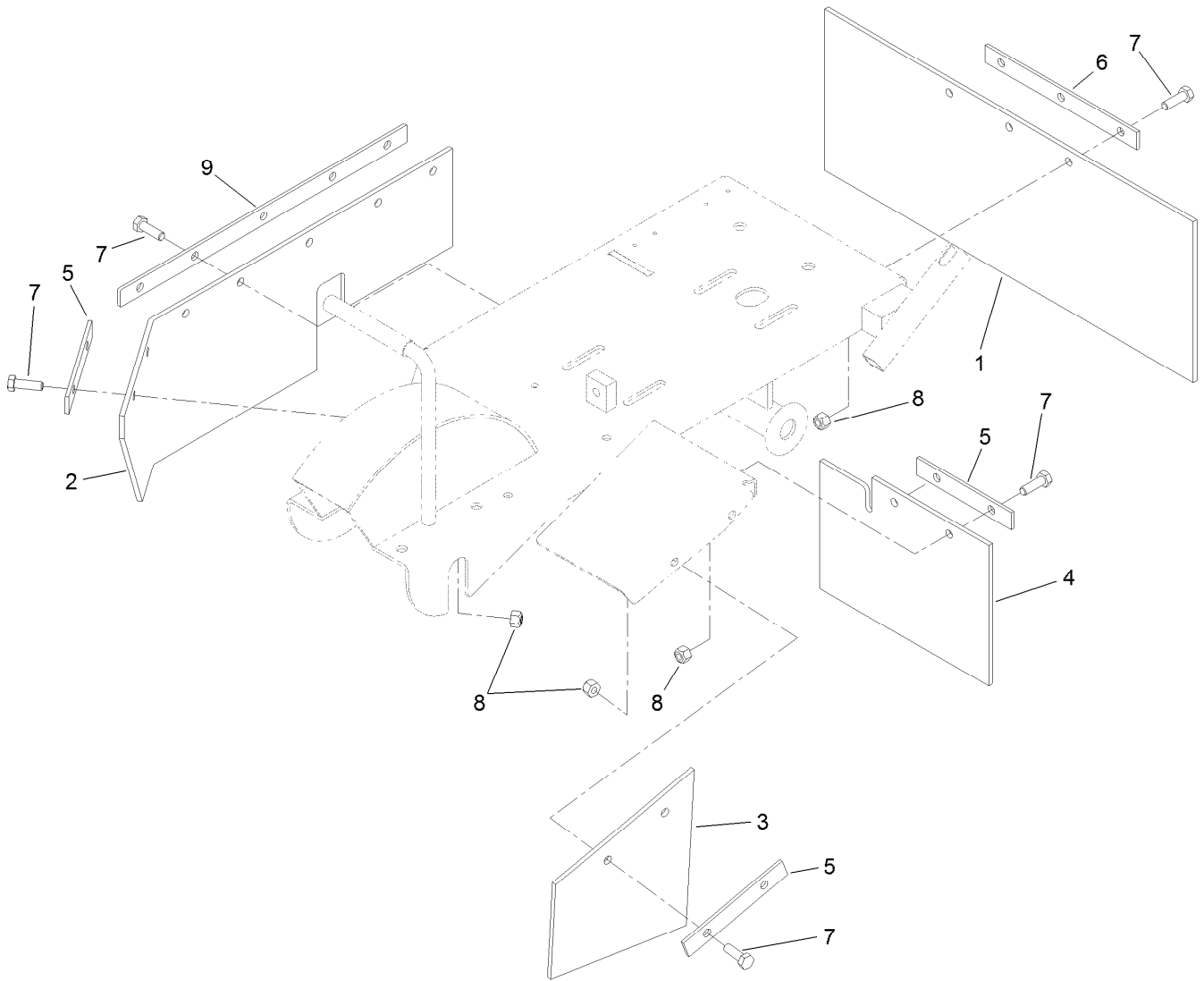

## Flap Assembly (continued)

<i>Ref.</i>	<i>Part Number</i>	<i>Qty.</i>	<i>Description</i>	<i>Ref.</i>	<i>Part Number</i>	<i>Qty.</i>	<i>Description</i>
1	120-5355	1	Flap-Rear	6	120-1246-01	1	Bracket-Support, Flap
2	120-5352	1	Flap-Right	7	322-5	14	Screw-HH
3	120-1313	1	Flap-Wing	8	3296-29	14	Nut-Lock, NI
4	120-5353	1	Flap-Wing, Rear	9	120-5354-01	1	Plate-Mounting, Flap
5	120-1315-01	3	Plate-Mounting, Flap				

# Belt Drive Assembly

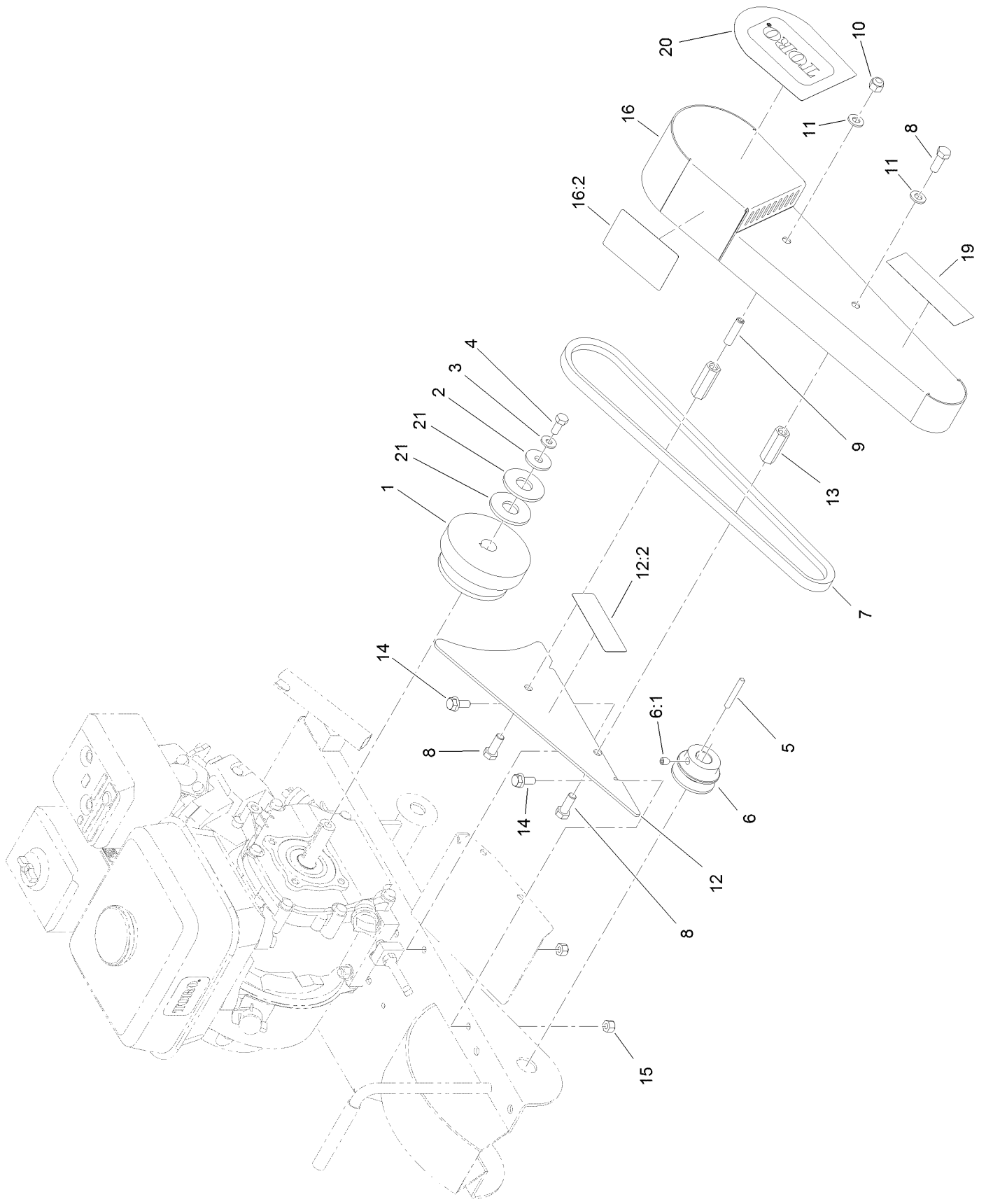

## Belt Drive Assembly (continued)

<i>Ref.</i>	<i>Part Number</i>	<i>Qty.</i>	<i>Description</i>	<i>Ref.</i>	<i>Part Number</i>	<i>Qty.</i>	<i>Description</i>
1	120-1215	1	Clutch-Centrifugal	11	3256-38	2	Washer-Flat
2	63-8410	1	Washer	12	121-4411	1	Plate-Guard, Inner
3	3256-2	1	Washer-Flat	12:2	117-4979	1	Decal-Warning, Shields
4	3210-3	1	Screw-HH	13	120-1332	2	Spacer-Guard, Belt
5	7-0036	2	Key-Square	14	3234-47	2	Screw-HHF
6	120-1303	1	Pulley-Front	15	3296-29	2	Nut-Lock, NI
6:1	3246-3	1	Screw-HSH	16	121-4412	1	Belt Guard ASM
7	120-1374	1	Belt-Drive	16:2	119-4692	1	Decal-Caution
8	323-6	3	Screw-HH	19	120-1815	1	Decal
9	3247-8	1	Screw-Set, HSH	20	119-4723	1	Decal
10	3296-39	1	Nut-Lock, NI	21	3256-8	2	Washer-Flat

# Attachments and Accessories

## For 22600 SGR-6 Stump Grinder

**Product Name**

**Model/Part**

Stump Grinder Blade Tote.....	22607
Blade Tote (Set of 6-Sharpended).....	22607-SH



**Notes:**

**Notes:**

**Notes:**



**Count on it.**