



Count on it.

Operator's Manual

**Dust-Control 66in Rake-O-Vac®
Sweeper**

Model No. 07055—Serial No. 314000001 and Up



This spark ignition system complies with Canadian ICES-002.

⚠ WARNING

CALIFORNIA Proposition 65 Warning

This product contains a chemical or chemicals known to the State of California to cause cancer, birth defects, or reproductive harm.

The engine exhaust from this product contains chemicals known to the State of California to cause cancer, birth defects, or other reproductive harm.

Model No. _____

Serial No. _____

This manual identifies potential hazards and has safety messages identified by the safety alert symbol (Figure 2), which signals a hazard that may cause serious injury or death if you do not follow the recommended precautions.



Figure 2

1. Safety alert symbol

Important: This engine is not equipped with a spark arrester muffler. It is a violation of California Public Resource Code Section 4442 to use or operate the engine on any forest-covered, brush-covered, or grass-covered land. Other states or federal areas may have similar laws.

This manual uses 2 other words to highlight information. **Important** calls attention to special mechanical information and **Note** emphasizes general information worthy of special attention.

Introduction

Read this information carefully to learn how to operate and maintain your product properly and to avoid injury and product damage. You are responsible for operating the product properly and safely.

You may contact Toro directly at www.Toro.com for product and accessory information, help finding a dealer, or to register your product.

Whenever you need service, genuine Toro parts, or additional information, contact an Authorized Service Dealer or Toro Customer Service and have the model and serial numbers of your product ready. Figure 1 illustrates the location of the model and serial numbers on the product. Write the numbers in the space provided.

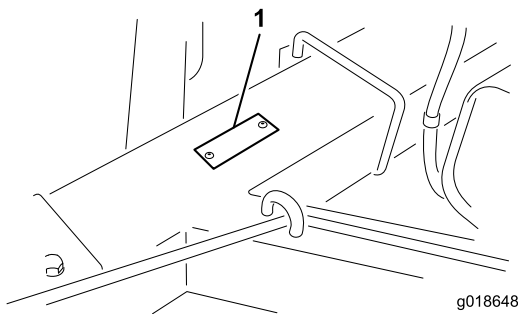

Figure 1

1. Location of the model and serial numbers

Contents

Introduction	2
Safety	4
Safe Operating Practices	4
Safety and Instructional Decals	6
Setup	8
1 Activating and Charging the Battery	8
2 Mount the Sweeper to the Prime Mover	9
3 Removing Sweeper from the Prime Mover	10
Product Overview	11
Controls	11
Specifications	12
Operation	12
Adding Fuel	12
Checking the Engine Oil Level	14
Starting and Stopping the Engine	14
Adjusting the Rake Depth	15
Inspect and Cleanup after Operation	15
Operating Tips	15
Maintenance	16
Recommended Maintenance Schedule(s)	16
Lubrication	17
Lubrication	17
Engine Maintenance	18
Servicing the Air Cleaner	18
Changing the Engine Oil and Filter	18
Servicing the Spark Plugs	19
Remove Debris from the Engine	19
Fuel System Maintenance	20
Replacing the Fuel Filter	20
Electrical System Maintenance	21
Servicing the Battery	21
Drive System Maintenance	22
Tire Maintenance	22
Belt Maintenance	22
Inspecting the Belts	22
Adjusting the Belts	23
Changing the Rubber Flap	24
Pulley Removal	25
Flex Tip Reel Removal	25
Flex Tip Rake Rod or Finger Plate Replacement	26
Flex Tip Rake Tine Replacement	26
Brush Half Replacement	27
Cleaning	27
Cleaning the Blower Housing	27
Storage	28

Safety

Improper use or maintenance by the operator or owner can result in injury. To reduce the potential for injury, comply with these safety instructions and always pay attention to the safety alert symbol, which means *Caution*, *Warning*, or *Danger*—personal safety instruction. Failure to comply with the instruction may result in personal injury or death.

Safe Operating Practices

Training

- Read the *Operator's Manual* and other training material. If the operator(s) or mechanic(s) can not read English it is the owner's responsibility to explain this material to them.
- Become familiar with the safe operation of the equipment, operator controls, and safety signs.
- All operators and mechanics should be trained. The owner is responsible for training the users.
- Never let children or untrained people operate or service the equipment. Local regulations may restrict the age of the operator.
- The owner/user can prevent and is responsible for accidents or injuries occurring to himself or herself, other people or property.
- The machine must be towed to operate, it is extremely important that the tow tractor be carefully selected to assure the best performance and safe operation.
- The tow tractor must have the proper wheel base, tread width, working seat belt, and must be equipped with a roll bar to operate safely on hilly terrain. The normal operating speed is 9 km/h (6 mph) but will vary with terrain and debris being picked up. The maximum transport speed is 32 km/h (20 mph) with slower speeds required on hilly terrain. Refer to tractor *Operator's Manual* for information or tractor service agency if you have any question on safe operation.
- The brakes of the tow tractor must have the capacity to stop the machine with hopper fully loaded and traveling at the maximum recommended transport speed.
- Ensure that the machine complies with local road requirements when being transported on public roads. A slow moving vehicle sign has been provided. Signal lights and brakes are not provided and may be required in some areas.

Preparation

- Evaluate the terrain to determine what accessories and attachments are needed to properly and safely perform the job. Only use accessories and attachments approved by the manufacturer.

- Wear the appropriate clothing including a hard hat, safety glasses, and hearing protection. Long hair, loose clothing, or jewelry may get tangled in moving parts.
- Check that the operator presence controls, safety switches, and shields are attached and functioning properly. Do not operate unless they are functioning properly.
- Keep all shields, safety devices, and decals in place. If a shield, safety device, or decal is malfunctioning, illegible, or damaged, replace it before operating the machine.

Safe Handling of Fuels

- To avoid personal injury or property damage, use extreme care in handling gasoline. Gasoline is extremely flammable and the vapors are explosive.
- Extinguish all cigarettes, cigars, pipes, and other sources of ignition.
- Use only an approved fuel container.
- Never remove fuel cap or add fuel with the engine running.
- Allow engine to cool before refueling.
- Never refuel the machine indoors.
- Never store the machine or fuel container where there is an open flame, spark, or pilot light such as on a water heater or on other appliances.
- Never fill containers inside a vehicle or on a truck or trailer bed with a plastic liner. Always place containers on the ground away from your vehicle before filling.
- Remove equipment from the truck or trailer and refuel it on the ground. If this is not possible, then refuel such equipment with a portable container, rather than from a fuel dispenser nozzle.
- Keep the nozzle in contact with the rim of the fuel tank or container opening at all times until fueling is complete. Do not use a nozzle lock open device.
- If fuel is spilled on clothing, change clothing immediately.
- Never overfill fuel tank. Replace fuel cap and tighten securely.

Operation

- Never run an engine in an enclosed area.
- Only operate in good light, keeping away from holes and hidden hazards.
- Be sure all drives are in neutral and parking brake is engaged before starting engine. Start the engine only from the operator's position.
- Never operate without the shields, covers, or other guards securely in place. Be sure all interlocks are functioning properly.
- Stop on a level ground, empty the hopper, and block the wheels before removing the sweeper from the prime mover.
- Shut the engine off and wait for all movement to stop. The impeller may momentarily turn after other

components have stopped. Use extreme caution when removing the cover from the blower housing.

- Keep hands and feet away from the sweeper area.
- Never carry passengers. Keep pets and bystanders away.
- Be alert, slow down, and use caution when making turns. Look behind and to the side of the machine before changing directions.
- Before backing up, look to the rear of the machine and ensure that no one is behind the machine.
- Slow down and use caution when crossing roads and sidewalks.
- Do not operate the machine under the influence of alcohol or drugs.
- Lightning can cause severe injury or death. If lightning is seen, or thunder is heard in the area, do not operate the machine; seek shelter.
- Use care when approaching blind corners, shrubs, trees, or other objects that may obscure vision.
- Use extreme caution around ditches, creeks, or other hazards.
- Avoid sudden stops and starts.
- If the machine vibrates abnormally, stop immediately, turn the engine off, wait for all motion to stop, and inspect for damage. Repair all of the damage before operation.
- Shut the sweeper blower off when dumping the contents of the hopper. Always stand to the extreme right or left side of the hopper when opening the tailgate.

Slope Operation

- Do not operate near drop-offs, ditches, steep banks, or water. Wheels dropping over edges can cause rollovers, which may result in serious injury or death.
- Do not operate on slopes when grass is wet. Slippery conditions reduce traction and could cause sliding and loss of control.
- Do not make sudden turns or rapid speed changes.
- Reduce speed and use extreme caution on slopes.
- Remove or mark obstacles such as rocks, tree limbs, etc. from the operating area. Tall grass can hide obstacles.
- Watch for ditches, holes, rocks, dips, and rises that change the operating angle, as rough terrain could overturn the aerator.
- Always avoid sudden starting or stopping on a slope. If tires lose traction, disengage the tines and proceed slowly off the slope.
- Follow the recommendations for wheel weights or counterweights to improve stability.

Maintenance and Storage

- Disengage the power to the machine, stop the engine, and wait for all movement to stop before adjusting, cleaning, repairing, or transporting.

- Clean the grass and debris from the rake tines, drives, mufflers, and engine to help prevent fires. Clean up any oil or fuel spillage.
- Let the engine cool before storing and do not store near flame.
- Shut off the fuel while storing or transporting on trailers. Do not store the fuel near flames or drain indoors.
- Disconnect the battery or remove the spark plug wires before making any repairs. Disconnect the negative terminal first and the positive terminal last. Reconnect the positive terminal first and the negative terminal last.
- Keep hands and feet away from any moving parts. If possible, do not make adjustments with the engine running.
- Do not overspeed the engine by changing the governor settings. To ensure safety and accuracy, have an authorized Toro distributor check the maximum engine speed with a tachometer.
- Let the engine cool before checking the oil or adding oil to the crankcase.
- Check the prime mover brakes and all safety equipment periodically.
- Charge the battery in an open, well ventilated area, away from spark and flames. Unplug the charger before connecting or disconnecting it from the battery. Wear protective clothing and use insulated tools.
- Keep all of the parts in good working condition and all hardware tightened. Replace all of the worn or damaged decals.
- Use only Toro-approved attachments. The warranty may be voided if the machine is used with unapproved attachments.

Hauling

- Use care when loading or unloading the machine into a trailer or truck.
- Use full width ramps for loading machine into trailer or truck.
- Tie the machine down securely using straps, chains, cable, or ropes. Both front and rear straps should be directed down and outward from the machine.

Safety and Instructional Decals



Safety decals and instructions are easily visible to the operator and are located near any area of potential danger. Replace any decal that is damaged or lost.

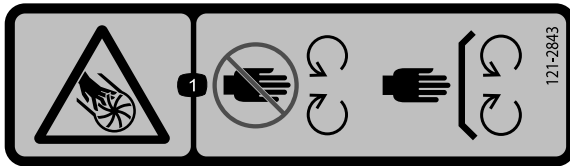

121-2843

1. Severing of fingers or hand, impeller blade—keep hands and feet away from moving parts; keep all guards in place.

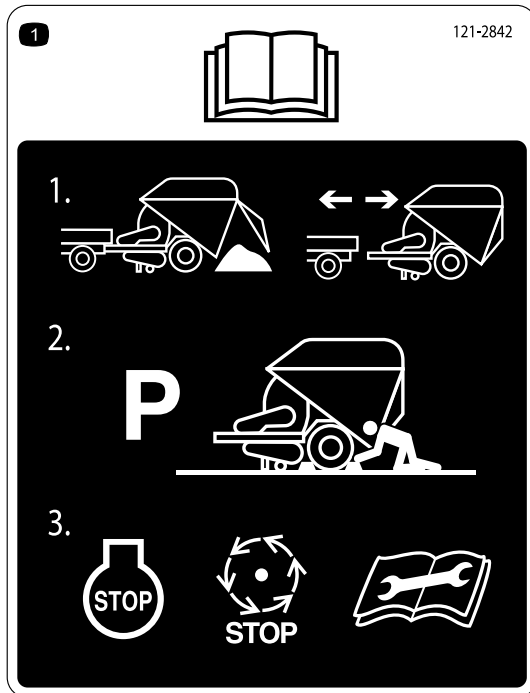

121-2842

1. Read the *Operator's Manual*—1) Disconnect the hitch only when the hopper is empty; do not disconnect when the hopper is loaded or partially loaded. 2) Park the unit on a flat surface and block the wheels when disconnected from the tow vehicle. 3) Stop the engine and wait for all moving parts to stop before servicing the machine.

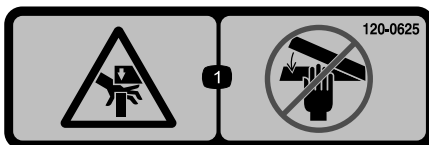

120-0625

1. Pinch point, hand—keep hands away.

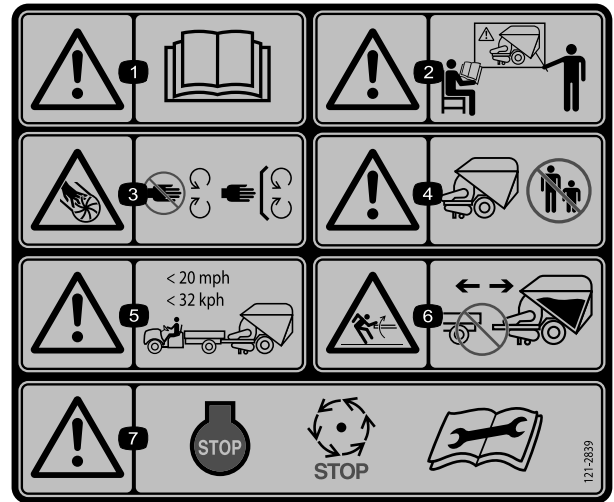

121-2839

1. Warning—read the *Operator's Manual*.
2. Warning—do not operate this machine unless you are trained.
3. Severing of fingers or hand, impeller blade—keep hands and feet away from moving parts; keep all guards in place.
4. Warning—keep bystanders away from the machine.
5. Warning—do not tow the vehicle in excess of 32 kph (20 mph).
6. Stored energy hazard—disconnect hitch only when the hopper is empty; do not disconnect when the hopper is loaded or partially loaded.
7. Warning—stop the engine and wait for all moving parts to stop before servicing the machine.

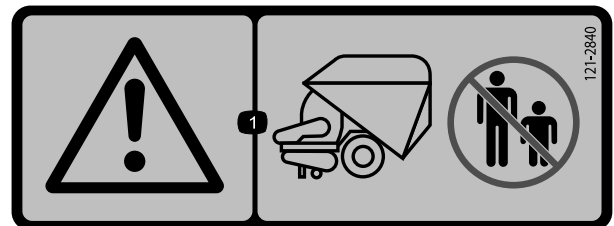

121-2840

1. Warning—keep bystanders away from the rear of the towing unit.

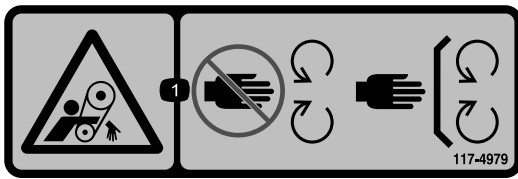

117-4979

1. Rotating belt — Keep guard in place



119-0217

1. Warning—stop the engine; stay away from moving parts; keep all guards and shields in place.

CALIFORNIA SPARK ARRESTER WARNING
 Operation of this equipment may create sparks that can start fires around dry vegetation. A spark arrester may be required. The operator should contact local fire agencies for laws or regulations relating to fire prevention requirements. 117-2718

117-2718

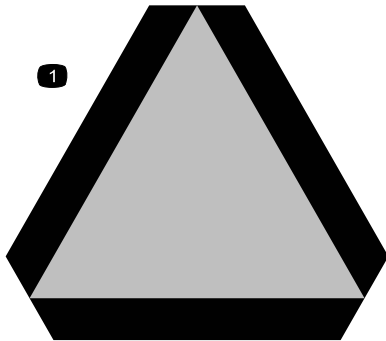

13-2930

1. Slow moving vehicle symbol



119-6807

1. Warning—no step

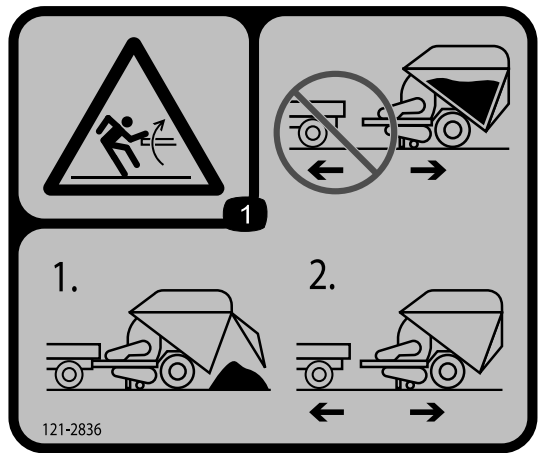

121-2836

1. Stored energy hazard, hopper—do not disconnect when the hopper is loaded; 1) Unload the hopper; 2) Disconnect the hopper.

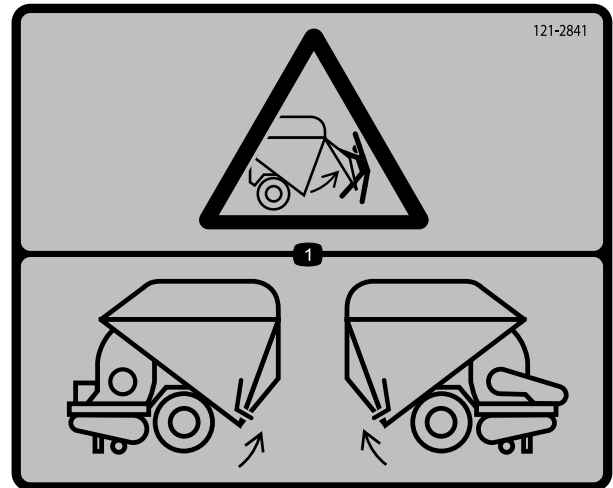

121-2841

1. Unlatched door hazard—door must be latched on both sides. Check both sides before loading the hopper.

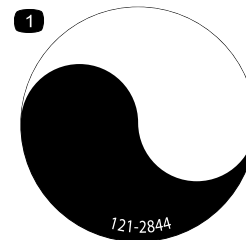

121-2844

1. Rotating shaft

Setup

Loose Parts

Use the chart below to verify that all parts have been shipped.

Procedure	Description	Qty.	Use
1	No parts required	–	Activate and charge the battery.
2	Hitch pin Lynch pin	1 1	Mount sweeper to prime mover.
3	No parts required	–	Removing sweeper from prime mover.

Media and Additional Parts

Description	Qty.	Use
Operator's Manual Engine Operator's Manual	1 1	Read before operating the machine.
Parts Catalog	1	View and order parts.

Note: Determine the left and right sides of the machine from the normal operating position.



Activating and Charging the Battery

No Parts Required

Procedure

WARNING

CALIFORNIA Proposition 65 Warning

Battery posts, terminals, and related accessories contain lead and lead compounds, chemicals known to the State of California to cause cancer and reproductive harm.
Wash hands after handling.

1. Unlatch and open the battery compartment cover.
2. Remove the battery from the battery compartment.
3. Clean the top of the battery and remove the vent caps.
4. Carefully fill each cell with electrolyte until the electrolyte is up to the fill line.

Use only electrolyte (1.260 Specific Gravity) to fill the battery initially.

Important: Do not add electrolyte while the battery is in the machine. You could spill it, causing corrosion.

⚠ DANGER

Battery electrolyte contains sulfuric acid which is a deadly poison and causes severe burns.

- Do not drink electrolyte and avoid contact with skin, eyes, or clothing. Wear safety glasses to shield your eyes and rubber gloves to protect your hands.
 - Fill the battery where clean water is always available for flushing the skin.
5. Connect a 3 to 4 amp battery charger to the battery posts. Charge the battery at a rate of 3 to 4 amps for 4 to 8 hours.
 6. Remove the filler caps and slowly add electrolyte to each cell until the level is up to the fill line. Install the filler caps.

Important: Do not overfill the battery. Electrolyte will overflow onto other parts of the machine and severe corrosion and deterioration will result.

⚠ WARNING

Charging the battery produces gasses that can explode.

Never smoke near the battery and keep sparks and flames away from the battery.

7. When the battery is charged, disconnect the charger from the electrical outlet and battery posts. Allow the battery to sit for 5 to 10 minutes before proceeding to the next step.

Note: After the battery has been activated, add only distilled water to replace normal loss, although maintenance-free batteries should not require water under normal operating conditions.

8. Insert the battery into the tray in the battery compartment. Position the battery so that the terminals are to the inside.

⚠ WARNING

Battery terminals or metal tools could short against metal machine components causing sparks. Sparks can cause the battery gasses to explode, resulting in personal injury.

- When removing or installing the battery, do not allow the battery terminals to touch any metal parts of the machine.
- Do not allow metal tools to short between the battery terminals and metal parts of the machine.

⚠ WARNING

Battery terminals or metal tools could short against metal tractor components causing sparks. Sparks can cause the battery gasses to explode, resulting in personal injury.

- When removing or installing the battery, do not allow the battery terminals to touch any metal parts of the tractor.
 - Do not allow metal tools to short between the battery terminals and metal parts of the tractor.
9. Attach the positive cable (red cable from the ignition switch) to the positive (+) terminal.
 10. Attach the negative cable (black cable from the engine block) to the negative (-) terminal of the battery.

Important: Make sure there is clearance between the battery cables and the speed selector lever.

Verify that the speed selector lever does not come within 1 inch (2.5 cm) of either battery cable when it is moved through its entire range of motion. Do not wire tie or tape the negative and positive battery cables together.

⚠ WARNING

Incorrect battery cable routing could damage the machine and cables causing sparks. Sparks can cause the battery gasses to explode, resulting in personal injury.

- Always *disconnect* the negative (black) battery cable before disconnecting the positive (red) cable.
- Always *connect* the positive (red) battery cable before connecting the negative (black) cable.

11. Coat the terminals and mounting fasteners with petroleum jelly to prevent corrosion.
12. Install the battery cover and secure it with the springs.

2

Mount the Sweeper to the Prime Mover

Parts needed for this procedure:

1	Hitch pin
1	Lynch pin

Procedure

To ensure proper debris pickup, make sure the sweeper frame is parallel with the ground.

1. Position the machine on a flat, level surface.
2. Remove the pin and rotate the jack to the ground. Align the holes and install the pin.
3. Adjust the jack so that the distance from the top of the frame to the ground is approximately 59.7 cm (23-1/2 inches) (Figure 3).

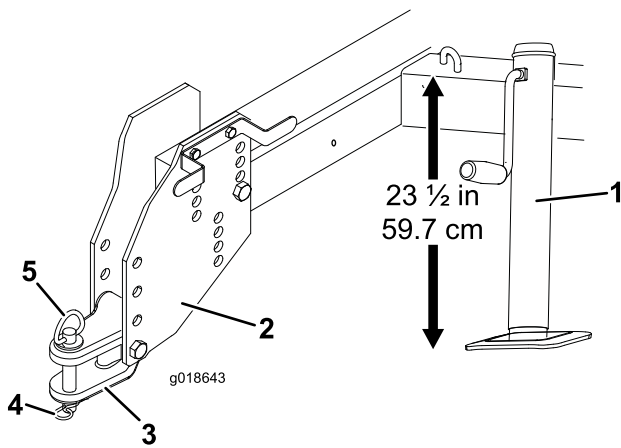

Figure 3

- | | |
|-----------------|--------------|
| 1. Jack | 4. Lynch pin |
| 2. Hitch plate | 5. Hitch pin |
| 3. Hitch tongue | |

2. Remove the pin and rotate the jack down. Align the holes and install the pin.
3. Lower the jack to the ground to stabilize the machine.
4. Continue to raise the sweeper with a jack until the lynch pin and hitch pin can be removed from the hitch.
5. Move the prime mover away from the sweeper.
6. Store the lynch pin and hitch pin in the sweeper hitch tongue.

4. Back the prime mover up to the sweeper.
5. Adjust the sweeper hitch tongue to the same level as the hitch of the prime mover as follows:
 - Remove the bolts and locknuts securing the hitch tongue to the hitch plates (Figure 3).
 - Raise or lower the hitch tongue to the position approximately level with the prime move hitch and secure it with the bolts and locknuts.

Note: If additional height is required, the hitch plates may be removed, raised, lowered or reversed.
6. Secure the hitch tongue to the prime mover hitch with the hitch pin and lynch pin (Figure 3).
7. Raise the jack, remove the pin, rotate the jack to the storage position and secure with the pin.

3

Removing Sweeper from the Prime Mover

No Parts Required

Procedure

⚠ WARNING

Always empty the sweeper hopper before disconnecting the hopper from the prime mover or the sweeper may tip backwards and cause injury.

1. Park the sweeper on a level surface and block the wheels.

Product Overview

Controls

Flap Lever

Move the flap lever downward to the engaged position and upward for the disengaged position. Move the lever to the upward position when transporting the machine.

Note: The flap may be positioned in the raised position when picking up large amounts of leaves.

Reel Lever

Move the reel lever forward to raise the flex tip reel. To lower the flex reel, move the lever forward, release the catch, then move the lever to the rear until it hits the stop. Move the lever to the raised position when the machine is not in operation, when storing the machine, or when transporting the machine (Figure 4).

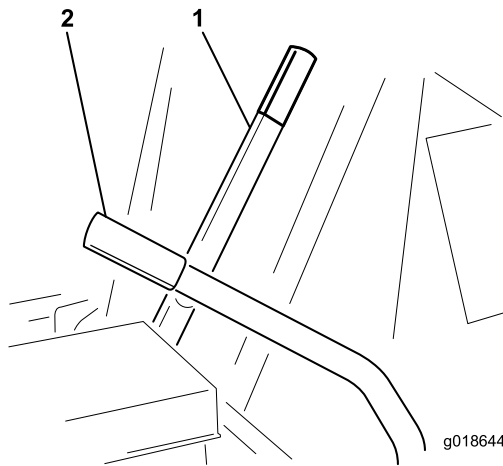

Figure 4

1. Flap lever
2. Reel lever

Choke Control

To start a cold engine, close the carburetor choke by moving the choke control lever to the On position. After the engine starts, regulate the choke to keep the engine running smoothly. Open the choke by moving the lever to the Off position. Starting a warm engine requires little or no choking (Figure 5).

Ignition Switch

The ignition switch, which is used to start and stop the engine, has three positions: Off, Run, and Start. Rotate the key clockwise to the Start position to engage the starter motor. Release the key when the engine starts (Figure 5). The key will move automatically to the Run position. To shut the engine off, rotate the key counterclockwise to the Off position.

Throttle Control

The throttle (Figure 5) is used to operate the engine at various speeds. Moving the throttle lever to the Fast position increases the engine speed. To decrease the engine speed, move the lever to the Slow position.

Note: When operating the sweeper, run the engine at full throttle. Operating the sweeper at a slow speed may cause clutch damage.

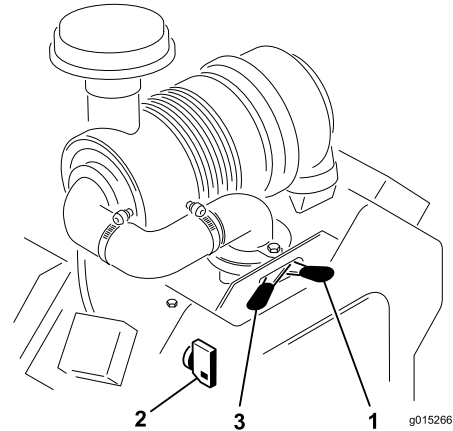

Figure 5

1. Choke control
2. Ignition switch
3. Throttle control

Tailgate Latch Rope

Pull the tailgate latch rope to unlatch the tailgate when emptying the hopper (Figure 6). When the rope is not in use, wind it around the harness mount.

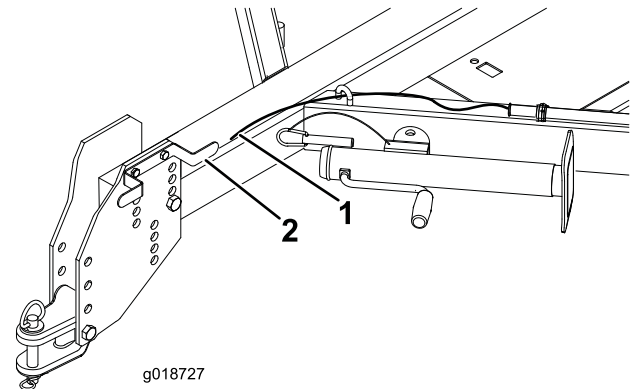
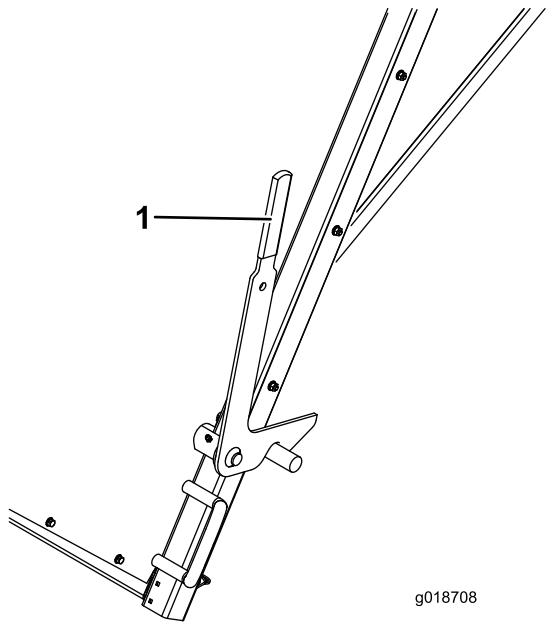

Figure 6

1. Tailgate latch rope
2. Harness mount

Tailgate Latch

The tailgate latch is used to assist in the unlatching of the tailgate when emptying the hopper (Figure 7).



g018708

Figure 7

1. Tailgate latch

Specifications

Note: Specifications and design are subject to change without notice.

Width	226 cm (89 inches)
Length	419 cm (165 inches)
Height	234 cm (92 inches)
Empty Weight	1322 kg (2914 lbs)

Operation

Note: Determine the left and right sides of the machine from the normal operating position.

Adding Fuel

- **Fuel tank capacity:** 37.8 liters (10 gallons)
- Recommended Fuel:
 - For best results, use only clean, fresh (less than 30 days old), unleaded gasoline with an octane rating of 87 or higher ((R+M)/2 rating method).
 - **Ethanol:** Gasoline with up to 10% ethanol (gasohol) or 15% MTBE (methyl tertiary butyl ether) by volume is acceptable. Ethanol and MTBE are not the same. Gasoline with 15% ethanol (E15) by volume is not approved for use. Never use gasoline that contains more than 10% ethanol by volume, such as E15 (contains 15% ethanol), E20 (contains 20% ethanol), or E85 (contains up to 85% ethanol). Using unapproved gasoline may cause performance problems and/or engine damage which may not be covered under warranty.
 - **Do not** use gasoline containing methanol.
 - **Do not** store fuel either in the fuel tank or fuel containers over the winter unless a fuel stabilizer is used.
 - **Do not** add oil to gasoline.

Important: Do not use fuel additives other than a fuel stabilizer/conditioner. Do not use fuel stabilizers with an alcohol base such as ethanol, methanol, or isopropanol.

⚠ DANGER

In certain conditions, gasoline is extremely flammable and highly explosive. A fire or explosion from gasoline can burn you and others and can damage property.

- Fill the fuel tank outdoors, in an open area, when the engine is cold. Wipe up any gasoline that spills.
- Do not fill the fuel tank completely full. Add gasoline to the fuel tank until the level is 25 mm (1 inch) below the bottom of the filler neck. This empty space in the tank allows gasoline to expand.
- Never smoke when handling gasoline, and stay away from an open flame or where gasoline fumes may be ignited by a spark.
- Store gasoline in an approved container and keep it out of the reach of children. Never buy more than a 30-day supply of gasoline.
- Do not operate without the entire exhaust system in place and in proper working condition.

⚠ DANGER

In certain conditions during fueling, static electricity can be released causing a spark which can ignite the gasoline vapors. A fire or explosion from gasoline can burn you and others and can damage property.

- Always place gasoline containers on the ground away from your vehicle before filling.
- Do not fill gasoline containers inside a vehicle or on a truck or trailer bed because interior carpets or plastic truck bed liners may insulate the container and slow the loss of any static charge.
- When practical, remove gas-powered equipment from the truck or trailer and refuel the equipment with its wheels on the ground.
- If this is not possible, then refuel such equipment on a truck or trailer from a portable container, rather than from a gasoline dispenser nozzle.
- If a gasoline dispenser nozzle must be used, keep the nozzle in contact with the rim of the fuel tank or container opening at all times until fueling is complete.

⚠ WARNING

Gasoline is harmful or fatal if swallowed. Long-term exposure to vapors can cause serious injury and illness.

- Avoid prolonged breathing of vapors.
- Keep face away from nozzle and gas tank or conditioner opening.
- Keep gas away from eyes and skin.

Filling the Fuel Tank

1. Clean around the fuel tank cap and remove it.
2. Fill the tank to approximately 25 mm (1 inch) below the top of the tank (the bottom of the filler neck).

Important: This space in the tank allows gasoline to expand. Do not fill the fuel tank completely full.

3. Install the fuel tank cap securely.
4. Wipe up any gasoline that may have spilled.

Checking the Engine Oil Level

Service Interval: Before each use or daily (Check the oil when the engine is cold.)

The engine is shipped with high-quality oil in the crankcase; however, the oil level must be checked before and after the engine is first started.

Crankcase capacity is approximately 1.9 liters (2 quarts) with the filter.

Note: The best time to check the engine oil is when the engine is cool before it has been started for the day. If it has already been run, allow the oil to drain back down to the sump for at least 10 minutes before checking. If the oil level is at or below the add mark on the dipstick, add oil to bring the oil level to the full mark. **Do not** overfill. If the oil level is between the full and add marks, no oil addition is required.

1. Park the machine on a level surface, stop the engine, remove the key, and wait for all moving parts to stop before leaving the operating position.
2. Clean around the oil dipstick so that dirt cannot fall into the filler hole and damage the engine (Figure 8).

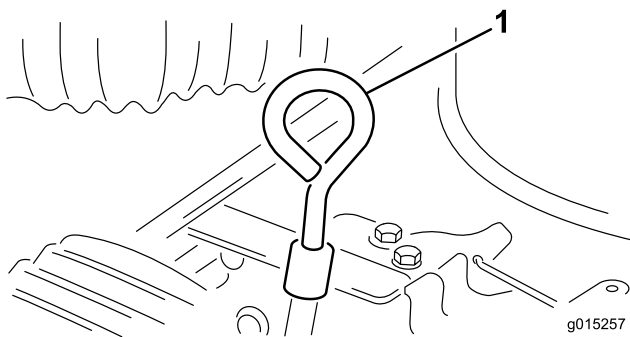

Figure 8

1. Dipstick

3. Remove the dipstick, wipe it clean, and install it until it is fully seated.
4. Remove the dipstick and check the oil level on the dipstick.

The oil level should be up to the Full mark on the metal end of the dipstick.

5. If the oil level is below the Full mark, remove the filler tube cap and add oil until the level reaches the Full mark on the dipstick (Figure 9). **Do not overfill.**

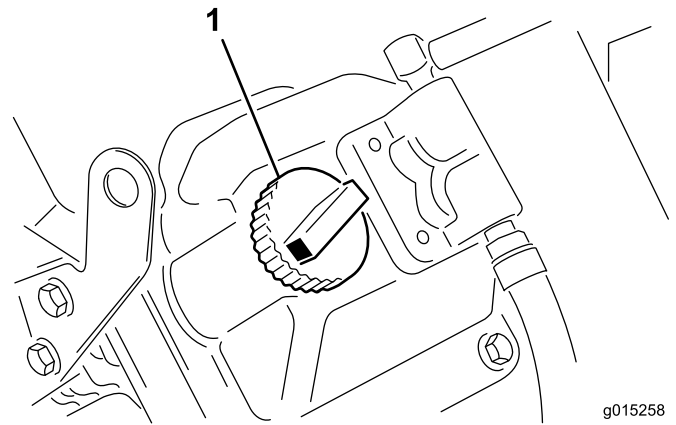

Figure 9

1. Filler cap

Important: Do not overfill the crankcase with oil because this may cause engine damage. Do not run the engine with oil below the low mark because the engine may be damaged as a result.

6. Install the filler tube cap and dipstick.

Starting and Stopping the Engine

Starting the Engine

1. Place all of the controls in the Off or Disengaged position.
2. Move the throttle lever midway between the Slow and Fast position.
3. Move the choke lever to the On position.

Note: Choke is not required when starting a warm engine.

4. Insert the key into the ignition switch and rotate it clockwise to start the engine. Release the key when the engine starts. Regulate the choke to keep the engine running smoothly.

Important: To prevent overheating of the starter motor, do not engage the starter longer than 10 seconds. After 10 seconds of continuous cranking, wait 60 seconds before engaging the starter motor again.

5. Move the throttle lever to the desired engine speed.
6. Pull the flap lever as far forward as possible.
7. Push the reel lever forward until the catch releases, then push it to the rear until the lever hits Stop.

Note: Do not allow the sweeper to stand still with the rake engaged as turf damage may occur.

Stopping the Engine

1. Move the throttle lever to the Slow position.
2. Let the engine idle for 60 seconds.
3. Turn the ignition key to the Off position and remove the key.

Note: To stop the machine in an emergency, move the ignition switch to the Off position.

Adjusting the Rake Depth

The flex tip reel should be adjusted to ensure that the rake tips slightly touch surface but do not penetrate the turf. If the rake tips penetrate the turf, improper debris pickup could result.

1. Position the machine on a level surface.
2. Turn the depth adjustment bolt until the rake slightly contacts the top of the turf grass. If a broom is installed, slight contact should be made with the surface. When the broom is operating, the contact width surface should be about 25.4 mm (1 inch) wide across the entire length of the broom (Figure 10).

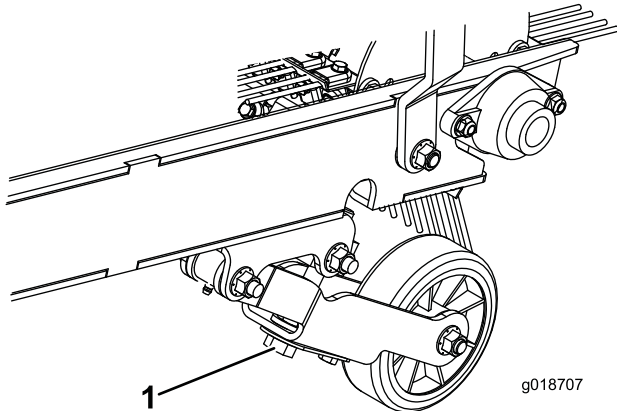

Figure 10

1. Depth adjusting bolt

3. Repeat the procedure on the opposite side of the machine.

Inspect and Cleanup after Operation

When the sweeping has been completed, thoroughly clean and wash the machine. Air out the dry hopper. After cleaning, it is recommended that the machine be inspected for possible damage to the mechanical components and blower. These procedures will ensure that the machine will perform satisfactorily during the next sweeping operation.

Important: When towing the sweeper for long distances, fasten the gauge wheel arm securely to the sweeper frame with the transport hooks. Should the gauge wheel arm fall to the ground, damage to the sweeper may occur.

Operating Tips

General

- Before starting to sweep, survey area to determine the best direction to sweep.
- **Note:** To maintain a straight line when sweeping, sight of an object in the foreground.
- Always try to make a long, continuous run with a slight overlap on the return run.
- On turf areas, the flex tip reel will pick up twigs, clippings, leaves, pine needles and cones, small debris (beverage cans, small bottles, paper plates, etc.).
- The rake teeth are made of flexible nylon and easily changed. To prevent damage, the rake is protected from solid obstructions by spring action. The nylon teeth will not mar bronze, stone markers, sidewalks or pavement.
- Because of its unique design, the sweeper also grooms the turf. The flex tip reel combs through and lifts grass for a uniform cut when mowed. As it cleans, the light scarifying action increase water and pesticide penetration, thus reducing the need for renovation.

Important: Do not make sharp turns when using the thatching reel as damage to turf may occur.

Important: Do not operate sweeper while reel is turning and in the raised position. Damage to the rake and tires may result if teeth come in contact with tires.

- To empty hopper, pull tailgate latch rope.

⚠ CAUTION

This product may exceed noise levels of 85 dB(A) at the operator position. Ear protectors are recommended, for prolonged exposure, to reduce the potential of permanent hearing damage.

Maintenance

Note: Determine the left and right sides of the machine from the normal operating position.

Important: Refer to your engine *Operator's Manual* for additional maintenance procedures.

Recommended Maintenance Schedule(s)

Maintenance Service Interval	Maintenance Procedure
After the first 50 hours	<ul style="list-style-type: none">• Change the engine oil and filter.
Before each use or daily	<ul style="list-style-type: none">• Check the engine oil level. (Check the oil when the engine is cold.)• Check the tire pressure.
Every 25 hours	<ul style="list-style-type: none">• Lubricate the bearings.• Service the Air Cleaner.• Check the electrolyte level and clean the battery.• Check the battery cable connections.
Every 100 hours	<ul style="list-style-type: none">• Change the engine oil and filter.• Remove debris from engine.
Every 200 hours	<ul style="list-style-type: none">• Service the primary air filter• Check the spark plugs.
Every 600 hours	<ul style="list-style-type: none">• Service the safety air filter• Replace the fuel filter.
Before storage	<ul style="list-style-type: none">• Refer to the Storage section for procedures necessary to perform before storing the machine for more than 30 days.

Lubrication

Lubrication

Service Interval: Every 25 hours

The Rake-O-Vac has grease fittings that must be lubricated regularly with No. 2 General Purpose Lithium Base Grease. Lubricate the bearings after every 30 hours of operation or whenever machine is washed with water. Bearings and bushings must be lubricated daily when operating conditions are extremely dusty and dirty. Dusty and dirty operating conditions could cause dirt to get into the bearings and bushings, resulting in accelerated wear. The grease fittings that must be lubricated are: the gauge wheel bearings, the reel shaft bearings, the impeller shaft bearings, the jackshaft bearings, and the left and right trailing arms.

1. Wipe the grease fittings clean to ensure that foreign matter cannot be forced into the bearing or bushing.
2. Pump grease into the bearing or bushing (Figure 11, Figure 12, and Figure 13).

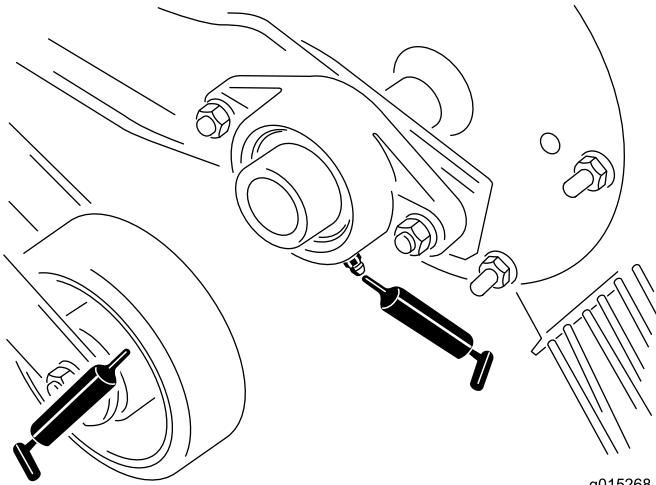

Figure 11

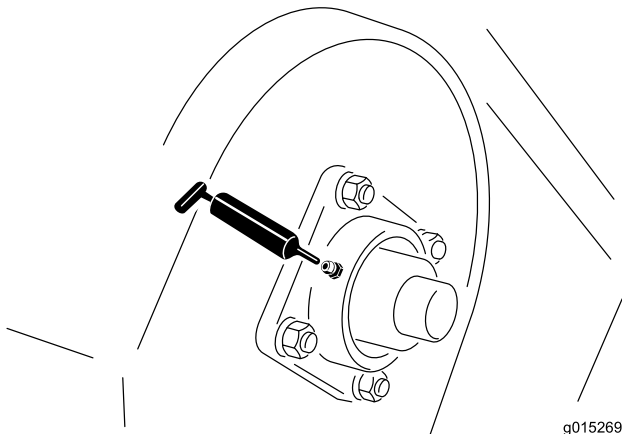

Figure 12

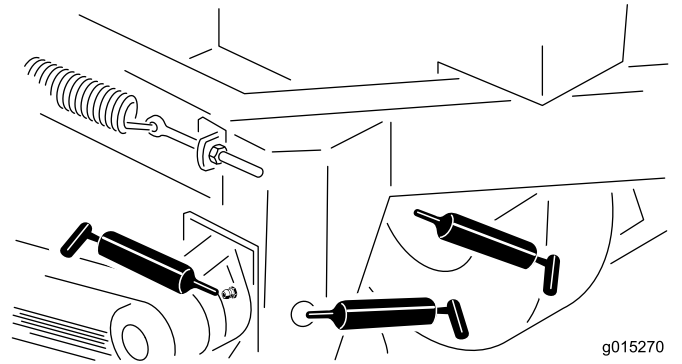

Figure 13

3. Wipe up any excess grease.

Engine Maintenance

Servicing the Air Cleaner

Service Interval: Every 25 hours

Check the air cleaner housing for damage which could cause an air leak. Replace if damaged. Check the whole intake system for leaks, damage or loose hose clamps

Removing the Air Filters

1. Stop the engine, remove the key, and wait for all moving parts to stop before leaving the operating position.
2. Release latches securing air cleaner cover to air cleaner body. Separate cover from body (Figure 14).

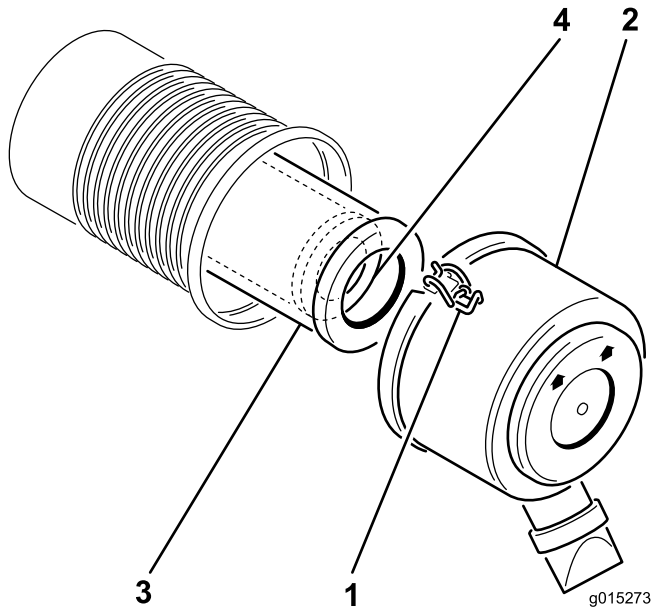

Figure 14

- | | |
|----------------------|-------------------|
| 1. Latch | 3. Primary filter |
| 2. Air cleaner cover | 4. Safety filter |

3. Clean the inside of the air cleaner cover with compressed air.
 4. Gently slide the primary filter out of the air cleaner housing (Figure 14).
- Note:** Avoid knocking the filter into the side of the housing.
5. Remove the safety filter only if you intend to replace it.

Important: Never attempt to clean the safety filter. If the safety filter is dirty, then the primary filter is damaged. Replace both filters.

6. Inspect the primary filter for damage by looking into the filter while shining a bright light on the outside of the filter. Holes in the filter will appear as bright spots. If the filter is damaged, discard it.

Servicing the Primary Air Filter

Service Interval: Every 200 hours

- If the primary air filter is dirty, bent, or damaged, replace it.
- Do not clean the primary air filter.

Servicing the Safety Air Filter

Service Interval: Every 600 hours

Important: Never attempt to clean the safety air filter. If the safety air filter is dirty, then the primary air filter is damaged. Replace both filters.

Installing the Filters

Important: To prevent engine damage, always operate the engine with both air filters and cover installed.

1. If installing new filters, check each filter for shipping damage. Do not use a damaged filter.
2. If the safety filter is being replaced, carefully slide it into the filter body (Figure 14).
3. Carefully slide the primary filter over the safety filter (Figure 14).

Note: Ensure that the primary filter is fully seated by pushing on its outer rim while installing it.

Important: Do not press on the soft inside area of the filter.

4. Clean the dirt ejection port located in the removable cover. Remove the rubber outlet valve from the cover, clean the cavity and replace the outlet valve.
5. Install the air cleaner cover with the side indicated as up facing upward and secure the latches (Figure 14).

Changing the Engine Oil and Filter

Service Interval: After the first 50 hours

Every 100 hours—Change the engine oil and filter.

Note: Change the oil and filter more frequently when operating conditions are extremely dusty or sandy.

Oil Type: Detergent oil (API service SJ, SK, SL, or higher)

Crankcase Capacity: w/filter, 1.9 liters (2.0 quarts)

1. Start the engine and let it run for five minutes. This warms the oil so it drains better.
2. Park the machine so that the drain side is slightly lower than the opposite side to ensure that the oil drains completely.
3. Set the parking brake, stop the engine, and remove the key.
4. Place a pan below the oil drain. Remove the oil drain plug to allow the oil to drain (Figure 15).

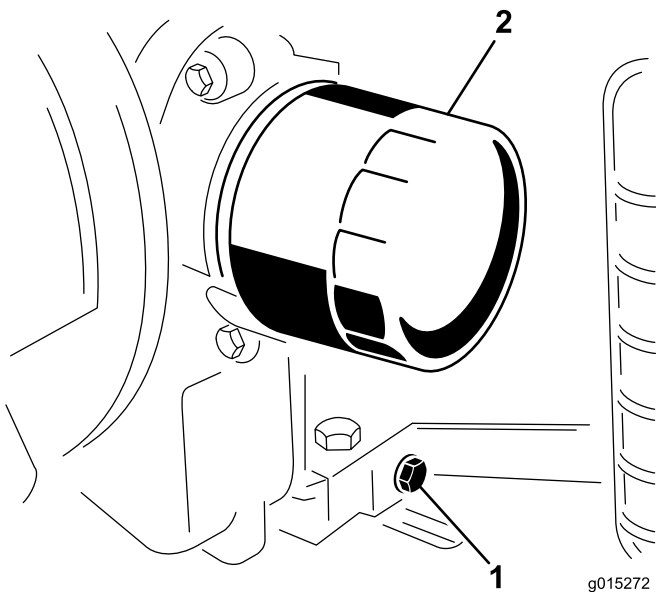

Figure 15

1. Drain plug 2. Oil filter

5. When the oil has drained completely, replace the plug.

Note: Dispose of the used oil at a certified recycling center.
6. Place a shallow pan or rag under the filter to catch oil.
7. Remove the old filter and wipe the surface of the filter adapter gasket.
8. Pour the new oil of the proper type through the center hole of the filter. Stop pouring when the oil reaches the bottom of the threads.
9. Allow a minute or two for the oil to be absorbed by filter material, then pour off the excess oil.
10. Apply a thin coat of new oil to the rubber gasket on the replacement filter.
11. Install the replacement oil filter to the filter adapter. Turn the oil filter clockwise until the rubber gasket contacts the filter adapter, then tighten the filter an additional 1/2 turn. **Do not** over tighten.
12. Check the oil level.
13. Slowly add additional oil to bring the level to the full mark on the dipstick.
14. Replace the fill cap.

Servicing the Spark Plugs

Service Interval: Every 200 hours—Check the spark plugs.

Ensure that the air gap between the center and side electrodes is correct before installing each spark plug. Use a spark plug wrench for removing and installing the spark plugs and a gapping tool/feeler gauge to check and adjust the air gap. Install new spark plugs if necessary.

Type: Champion RC12YC or equivalent. Air Gap: 0.75 mm (0.03 inch)

Removing the Spark Plugs

1. Stop the engine, set the parking brake, and remove the key.
2. Pull the wires off of the spark plugs.
3. Clean around the spark plugs.
4. Remove both spark plugs and metal washers.

Checking the Spark Plugs

1. Look at the center of both spark plugs (Figure 16). If you see light brown or gray on the insulator, the engine is operating properly. A black coating on the insulator usually means the air cleaner is dirty.

Important: Never clean the spark plugs. Always replace the spark plugs when they have a black coating, worn electrodes, an oily film, or cracks.

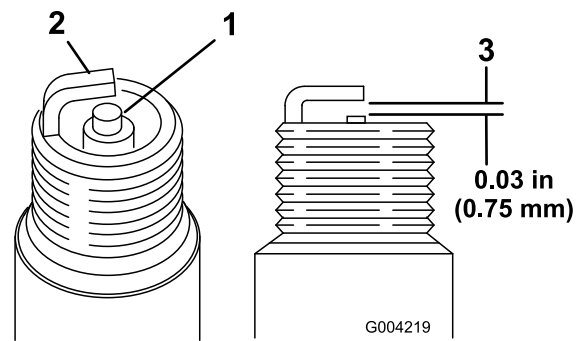

Figure 16

1. Center electrode insulator 3. Air gap (not to scale)
 2. Side electrode
-
2. Check the gap between the center and side electrodes (Figure 16).
 3. Bend the side electrode (Figure 16) if the gap is not correct.

Installing the Spark Plugs

1. Thread the spark plugs into the spark plug holes.
2. Tighten the spark plugs to 27 N-m (20 ft-lb).
3. Push the wires onto the spark plugs.

Remove Debris from the Engine

Service Interval: Every 100 hours

To ensure proper cooling, keep the grass screen, cooling fins, and other external surfaces of the engine clean at all times.

Every 100 hours of operation (more often under extremely dusty, dirty conditions) remove the blower housing and other cooling shrouds. Clean the cooling fins and external surfaces as necessary. Make sure the cooling shrouds are reinstalled.

Note: Operating the engine with a blocked grass screen, dirty or plugged cooling fins, or cooling shrouds removed, will cause engine damage due to overheating.

Fuel System Maintenance

Replacing the Fuel Filter

Service Interval: Every 600 hours/Yearly (whichever comes first)

Important: Never re-install a dirty filter if it is removed from the fuel line.

1. Stop the engine, remove the key, and wait for all moving parts to stop before leaving the operating position.
2. Allow the machine to cool down.
3. Place a clean container under the fuel filter (Figure 17).

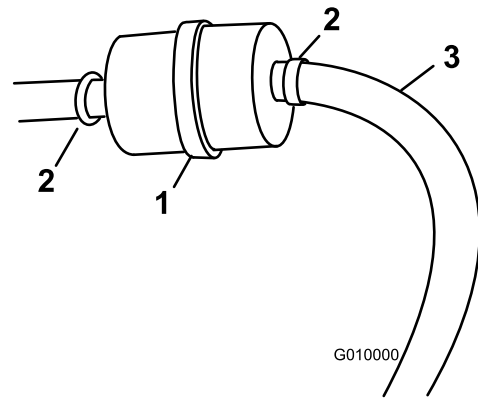

Figure 17

1. Fuel filter

-
4. Loosen the clamps securing the fuel filter to the fuel lines.
 5. Remove the filter from the fuel lines.
 6. Install a new filter to the fuel lines with the clamps previously removed. Filter is to be mounted so that the arrow points toward the carburetor.
 7. Wipe up any spilled fuel.

Electrical System Maintenance

Servicing the Battery

Service Interval: Every 25 hours—Check the electrolyte level and clean the battery.

Every 25 hours—Check the battery cable connections.

WARNING

CALIFORNIA Proposition 65 Warning

Battery posts, terminals, and related accessories contain lead and lead compounds, chemicals known to the State of California to cause cancer and reproductive harm.
Wash hands after handling.

⚠ DANGER

Battery electrolyte contains sulfuric acid which is a deadly poison and causes severe burns.

- Do not drink electrolyte and avoid contact with skin, eyes, or clothing. Wear safety glasses to shield your eyes and rubber gloves to protect your hands.
- Fill the battery where clean water is always available for flushing the skin.

The battery electrolyte level must be properly maintained and the top of the battery kept clean. If the machine is stored in a location where temperatures are extremely high, the battery will run down more rapidly than if the machine is stored in a location where temperatures are cool.

Check the electrolyte level every 25 operating hours or, if machine is in storage, every 30 days.

Maintain the cell level with distilled or demineralized water. Do not fill the cells above the bottom of the split ring inside each cell.

Keep the top of the battery clean by washing it periodically with a brush dipped in ammonia or bicarbonate of soda solution. Flush the top surface with water after cleaning. Do not remove the fill caps while cleaning.

The battery cables must be tight on the terminals to provide good electrical contact.

⚠ WARNING

Incorrect battery cable routing could damage the machine and cables causing sparks. Sparks can cause the battery gasses to explode, resulting in personal injury.

- Always *disconnect* the negative (black) battery cable before disconnecting the positive (red) cable.
- Always *connect* the positive (red) battery cable before connecting the negative (black) cable.

If corrosion occurs at the terminals, disconnect the cables (negative (–) cable first) and scrape clamps and terminals separately. Reconnect the cables (positive (+) cable first) and coat the terminals with petroleum jelly.

⚠ WARNING

Battery terminals or metal tools could short against metal tractor components causing sparks. Sparks can cause the battery gasses to explode, resulting in personal injury.

- When removing or installing the battery, do not allow the battery terminals to touch any metal parts of the machine.
- Do not allow metal tools to short between the battery terminals and metal parts of the machine.

Drive System Maintenance

Tire Maintenance

Checking the Tire Pressure

Service Interval: Before each use or daily

Maintain the air pressure in the front and rear tires at 193 kPa (28 psi). Check the pressure at the valve stem (Figure 18) before each use.

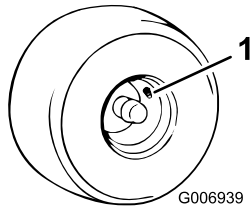

Figure 18

1. Valve stem

Changing the Tires

1. Park the machine on a flat, level surface. Block the other tire to prevent accidental rolling or injury.
2. Place the jack under the frame or axle shaft behind the wheel and jack up the wheel until it just contacts the floor.

⚠ WARNING

A 2000 lb. capacity hydraulic jack should be used when changing a tire.

3. Loosen all lug bolts and continue to jack up until the tire can be removed.
4. Reverse the above procedure to install a tire. Torque the lug bolts to 95–122 N-m (70–90 ft-lb).

Belt Maintenance

Inspecting the Belts

Note: It is not necessary to remove the upper belt guard (Figure 19) to check the belt tension. If for some reason the belt guard must be removed, remove the 4 bolts, washers, and nuts securing the guard to the frame. Never operate the machine without the guards in place.

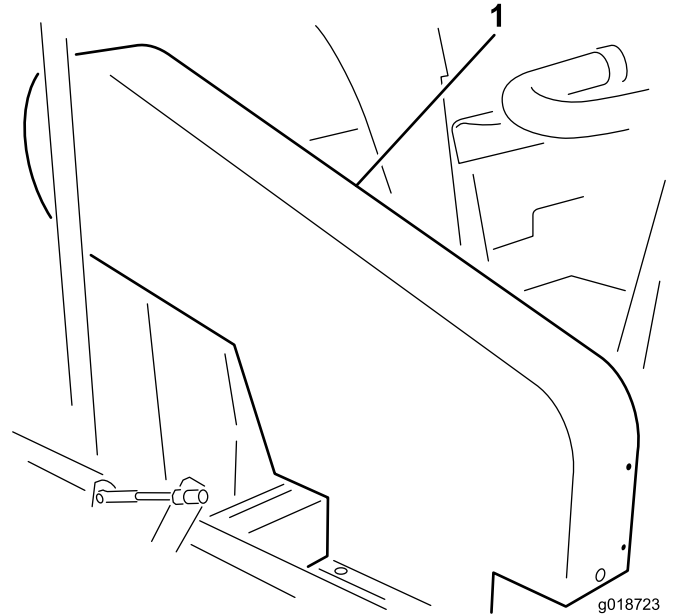

Figure 19

1. Upper belt guard

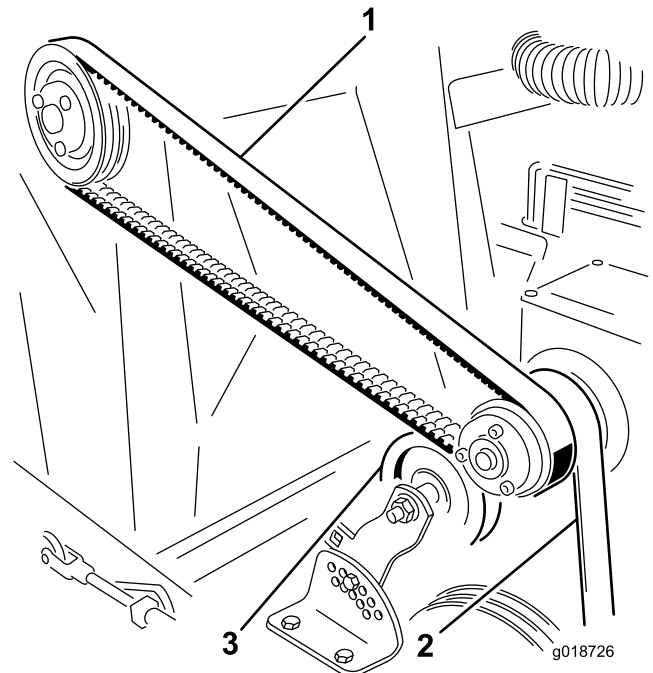

Figure 20

1. Impeller belt
2. Jackshaft belt
3. Idler pulley

Inspecting the Impeller Drive Belt

Check the tension by depressing the belt at the mid span of the impeller and clutch pulleys with 18–22 N (4–5 lbs) of force. The belt should deflect 1.27 cm (.5 inches). If the deflection is incorrect, proceed to Adjusting the Impeller Drive Belt. If the deflection is correct, continue normal operation (Figure 19).

Inspecting the Jackshaft Belt

Check the tension by depressing the belt at mid span of the jackshaft and clutch pulleys with 18–22 N (4–5 lbs) of force. The belt should deflect 6.35 mm (.25 inches). If the deflection is incorrect, proceed to Adjusting the Jackshaft Belt. If the deflection is correct, continue normal operation (Figure 19).

Inspecting the Reel Drive Belt

Check the tension by depressing the belt at mid span of the idler pulley and the reel driver pulley with 111–129 N (25–29 lbs) of force. The belt should deflect 6.35 mm (.25 inches). If the deflection is incorrect, proceed to Adjusting the Reel Drive Belt. If the deflection is correct, continue normal operation.

Adjusting the Belts

Adjusting the Impeller Drive Belt

1. Loosen the engine mounting bolts (Figure 21).

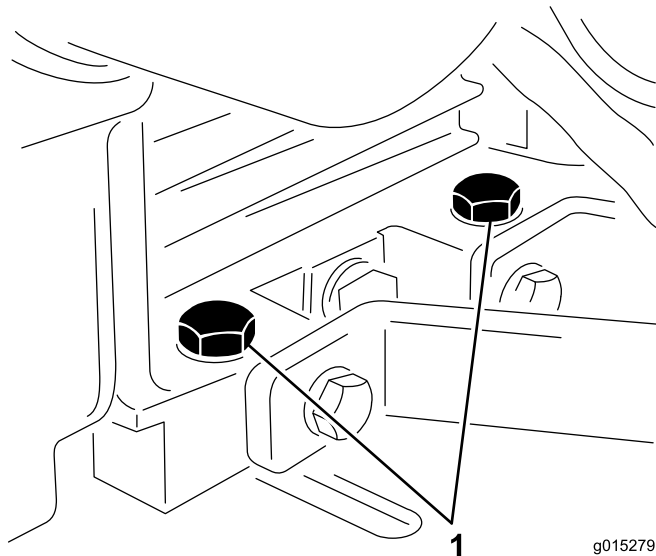

Figure 21

g015279

1. Engine mounting bolts

2. Turn the belt adjusting bolt until the desired belt tension is obtained. Slightly tighten the engine mounting bolts. Adjust the engine so that it is parallel with frame. Continue tightening the engine mounting bolts (Figure 22).

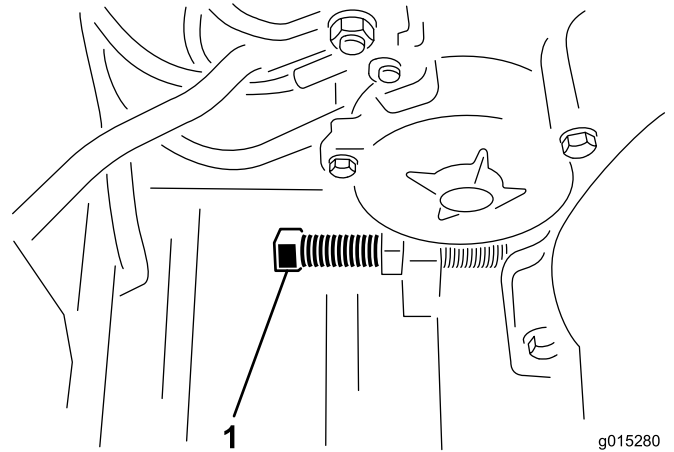

Figure 22

g015280

1. Adjusting bolt

3. Whenever the impeller belt is adjusted it is necessary to readjust the jackshaft belt (engine drive) or chain (PTO drive).

Adjusting the Jackshaft Belt

1. Remove the 4 bolts, washers and nuts securing the upper shroud to the frame (Figure 19).
2. Remove the nut and bolt securing the idler pulley bracket to the tension adjusting bracket (Figure 23).

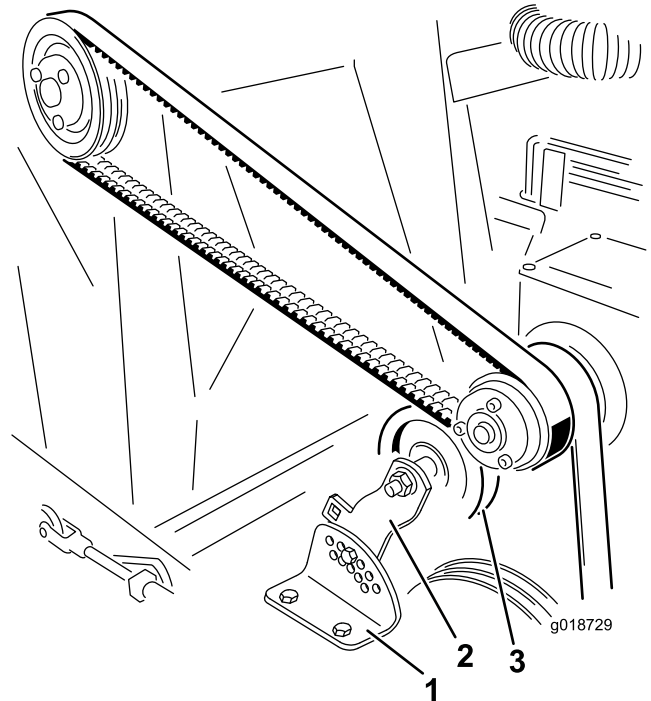

Figure 23

g018729

1. Tension adjusting bracket
2. Idler pulley
3. Idler pulley bracket

3. Press down on the idler pulley until the desired tension is obtained and the holes in the idler pulley bracket and the tension adjusting bracket are aligned.

4. Install the bolt and nut to secure the adjustment.
5. Reinstall the upper shroud.

Adjusting the Reel Drive Belt

1. Remove the nut and bolt securing the idler pulley bracket (bolt in slotted hole in bracket) to the tension adjusting bracket (Figure 24).

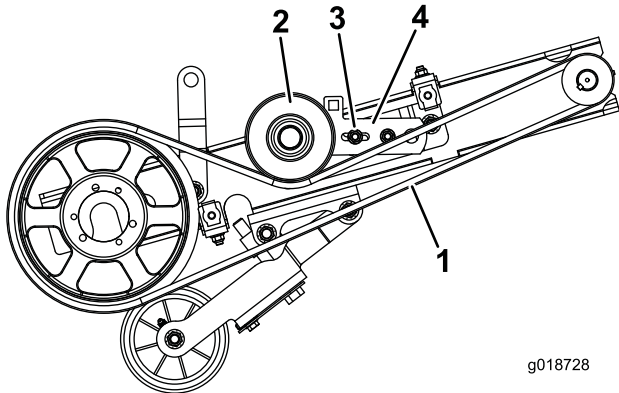

Figure 24

Cover removed for clarity

- | | |
|--------------------|--------------------------------|
| 1. Reel drive belt | 3. Bolt and nut (slotted hole) |
| 2. Idler pulley | 4. Idler pulley bracket |
-
2. Press down on the idler pulley until the desired tension is obtained and the holes in the idler pulley bracket and the tension adjusting bracket are aligned.
 3. Install the bolt and nut to secure the adjustment.

Changing the Rubber Flap

Replace the rubber flap when it becomes worn or damaged.

CAUTION

Change rubber flap on a flat, level surface and block wheels to prevent sweeper from rolling. Failure to do so may result in personal injury.

1. Remove the 10 bolts, washers, and nuts on the mounting flap and flap retainer (Figure 25).

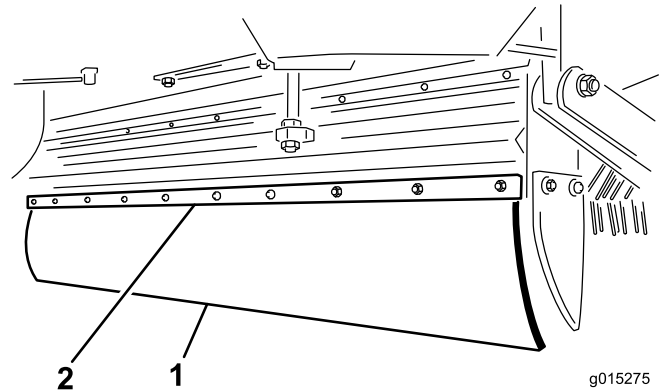

Figure 25

- | | |
|----------------|------------------|
| 1. Rubber flap | 2. Flap retainer |
|----------------|------------------|
-

2. Replace with the new rubber flap and fasten it securely.

Pulley Removal

1. Remove the bolts and lockwashers one at a time and screw them into the adjoining holes (Figure 26).

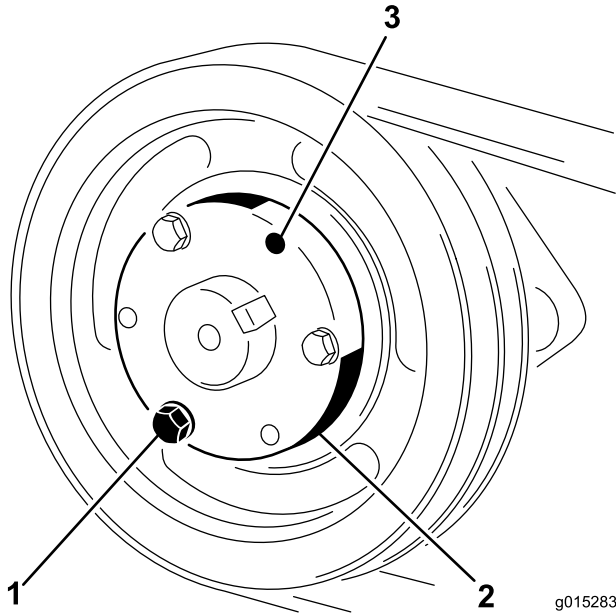

Figure 26

1. Bolts & locknuts
2. Taper lock bushing
3. Taper lock release hole

-
2. Turn each bolt the same number of times until the lock separates. The pulley will now slide off of the shaft.

Flex Tip Reel Removal

1. Place the machine on a hard and level surface.
2. Raise the front of the sweeper as high as possible by lowering the jack.
3. Raise the reel to the highest position.
4. Remove the lower belt guard and reel drive belt (Figure 24).
5. Remove the 2 bolts, lockwashers, and nuts securing the reel shaft bearings to the reel support arms on each side of the sweeper. Lower the flex tip reel to the ground.
6. Lift the reel support arms to the highest position.
7. Slide the end of the rake rearward and pull it out from under the machine.

Flex Tip Rake Rod or Finger Plate Replacement

1. Remove the bolt and locknut from one end of the reel (Figure 27).

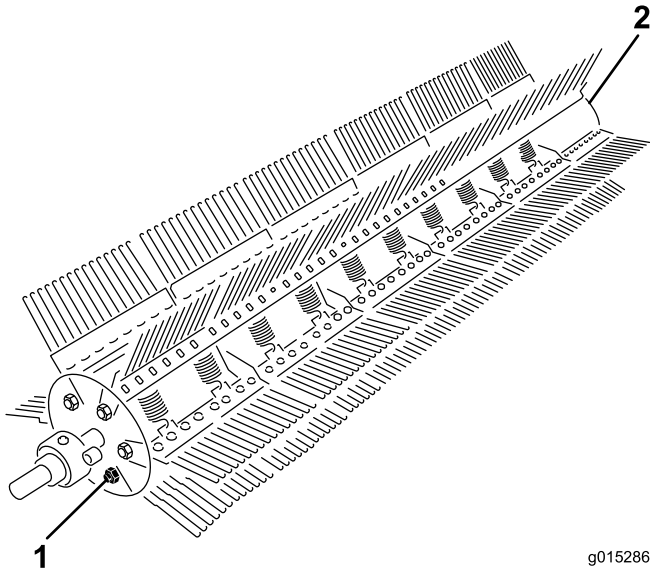

Figure 27

1. bolt and locknut
2. Locknut

2. Remove the locknut only from the opposite end of the reel.
3. Drive the rod from the end plate. Drive the rod from the end without the tab welded to it.
4. Remove the finger plates or rods as required and replace.
5. Line up the finger plate with the rod and drive the rod back through the end plate.
6. Attach the bolt, locknuts, and hook up the springs.

Flex Tip Rake Tine Replacement

1. Remove the tine retainer and slide the damaged tine out (Figure 28).

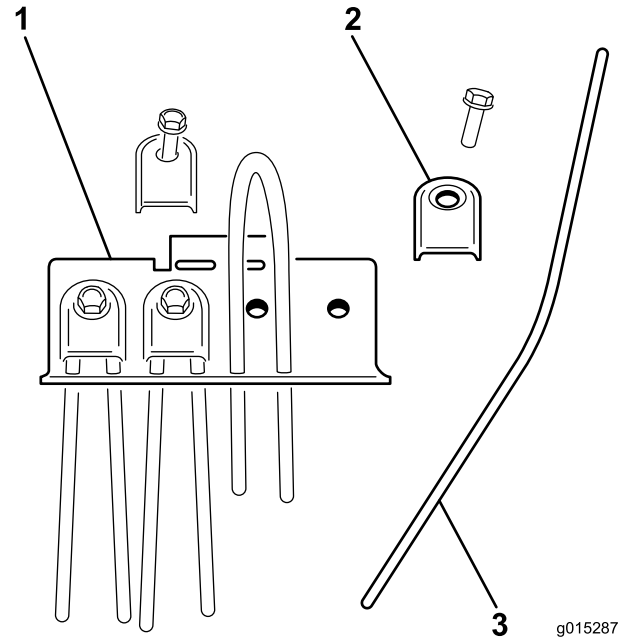

Figure 28

1. Finger plate
2. Tine retainer
3. Tine

2. Bend the new tine in half and slide it into position.
3. Place the tine bracket over the curved end of the tine and fasten it securely with the bolt and lockwasher.

Brush Half Replacement

1. Remove the brush from the sweeper.
2. Loosen the clamps with an Allen wrench and remove it from the brush halves (Figure 29).

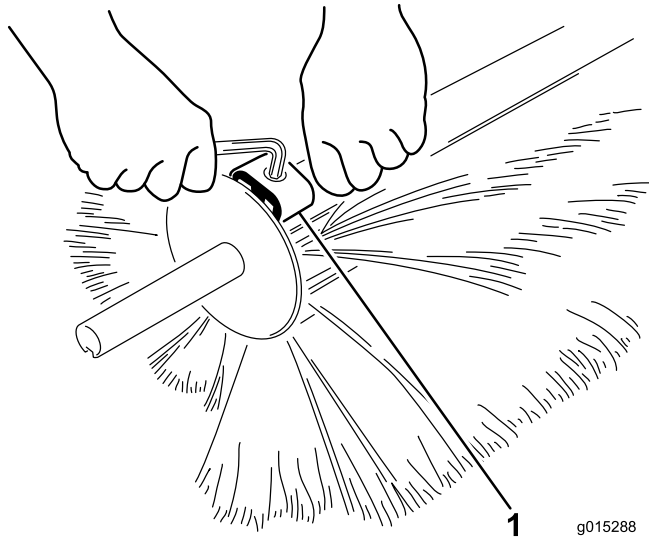

Figure 29

1. Clamp

3. Separate the brush halves and discard the damaged section(s) (Figure 30).

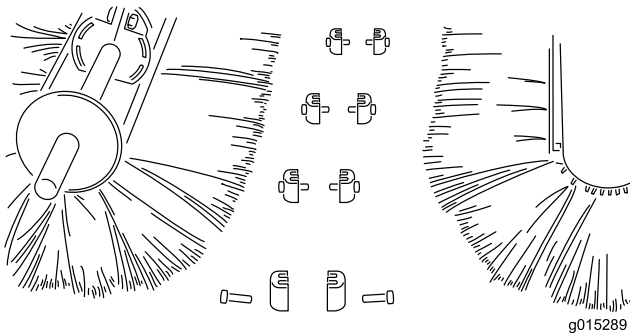

Figure 30

4. Install the new brush section by pushing them together and securing both ends with the brush clamps. When the ends have been secured, fasten the brush with the remaining clamps.

Cleaning

Cleaning the Blower Housing

⚠ WARNING

Before removing any debris from blower housing, disengage P.T.O. drive, stop engine(s) and make certain all moving parts have stopped or personal injury may occur.

1. Make sure the impeller has stopped rotating before removing the access plates.
2. Loosen the 2 wing nuts securing the access plate (Figure 31).

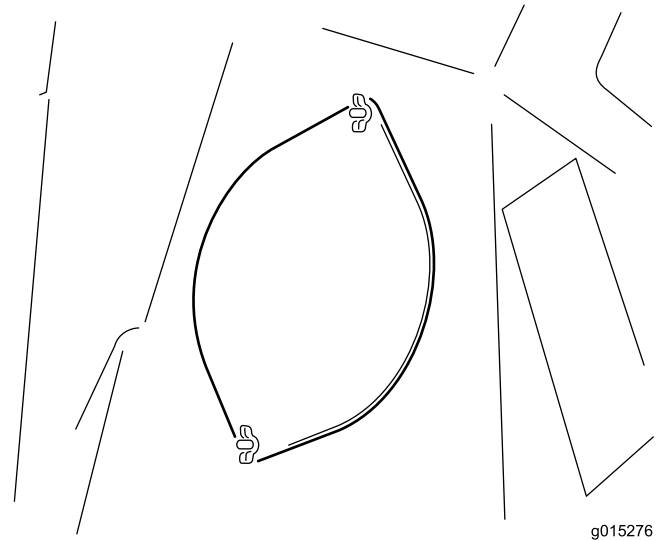

Figure 31
Access Plate

3. Swing the access plate to one side allowing the removal of debris.
4. After the debris has been removed, lower the access plate and secure with the wing nuts. Repeat the procedure on the other access plate.

Storage

1. Set the parking brake and turn the ignition key to off. Remove the spark plug wire and the key.
2. Remove grass, dirt, and grime from the external parts of the entire machine, especially the engine. Clean dirt and chaff from the outside of the engine's cylinder head fins and blower housing.
3. Service the air cleaner.
4. Change the crankcase oil.
5. Check the tire pressure.
6. Check the condition of the tines.
7. If you will be storing the machine for more than 30 days, prepare it as follows:
 - A. Remove the battery terminals from the battery posts and remove the battery from the machine.
 - B. Clean the battery, terminals, and posts with a wire brush and baking soda solution.
 - C. Coat the cable terminals and battery posts with Grafo 112X skin-over grease (Toro Part No. 505-47) or petroleum jelly to prevent corrosion.
 - D. Slowly recharge the battery every 60 days for 24 hours to prevent lead sulfation of the battery. To prevent the battery from freezing, make sure it is fully charged. The specific gravity of a fully charged battery is 1.265 to 1.299.

▲ WARNING

Charging the battery produces gasses that can explode.

Never smoke near the battery and keep sparks and flames away from it.

- E. Either store the battery on the shelf or on the machine. Leave the cables disconnected if it is stored on the machine. Store it in a cool atmosphere to avoid quick deterioration of the charge in the battery.
- F. Add a petroleum based stabilizer/conditioner to fuel in the tank. Follow mixing instructions from stabilizer manufacture. **Do not use an alcohol based stabilizer (ethanol or methanol).**

Note: A fuel stabilizer/conditioner is most effective when mixed with fresh gasoline and used at all times.
- G. Run the engine to distribute conditioned fuel through the fuel system (5 minutes).
- H. Stop the engine, allow it to cool and drain the fuel tank.
- I. Restart the engine and run it until it stops.

- J. Choke the engine. Start and run the engine until it will not start.
- K. Dispose of the fuel properly. Recycle as per local codes.

Important: Do not store stabilizer/conditioned gasoline over 90 days.

8. Remove the spark plugs and check the condition. With the spark plugs removed from the engine, pour two tablespoons of engine oil into each spark plug hole. Now use the starter to crank the engine and distribute the oil inside the cylinders. Install the spark plugs. Do not install the wires on the spark plugs.
9. Check and tighten all bolts, nuts, and screws. Repair or replace any part that is damaged or defective.
10. Wash and dry the entire unit. Remove the tines, clean and oil them. Spray light oil mist on the coring head bearings (crank & damper links).

Important: You can wash the machine with mild detergent and water. Do not pressure wash the machine. Avoid excessive use of water, especially near the engine.

Note: Run the machine with the engine at high idle for 2 to 5 minutes after washing.
11. Paint all scratched or bare metal surfaces. Paint is available from your Authorized Service Distributor.
12. Secure service latch if the aerator is to be stored for more than a couple days.
13. Store the machine in a clean, dry garage or storage area. Remove the key from the ignition switch and keep it out of reach of children or other unauthorized users.
14. Cover the machine to protect it and keep it clean.

Notes:

Notes:

Notes:



The Toro Total Coverage Guarantee

A Limited Warranty

Conditions and Products Covered

The Toro Company and its affiliate, Toro Warranty Company, pursuant to an agreement between them, jointly warrant your Toro Commercial product ("Product") to be free from defects in materials or workmanship for two years or 1500 operational hours*, whichever occurs first. This warranty is applicable to all products with the exception of Aerators (refer to separate warranty statements for these products). Where a warrantable condition exists, we will repair the Product at no cost to you including diagnostics, labor, parts, and transportation. This warranty begins on the date the Product is delivered to the original retail purchaser.

* Product equipped with an hour meter.

Instructions for Obtaining Warranty Service

You are responsible for notifying the Commercial Products Distributor or Authorized Commercial Products Dealer from whom you purchased the Product as soon as you believe a warrantable condition exists. If you need help locating a Commercial Products Distributor or Authorized Dealer, or if you have questions regarding your warranty rights or responsibilities, you may contact us at:

Toro Commercial Products Service Department
Toro Warranty Company
8111 Lyndale Avenue South
Bloomington, MN 55420-1196
952-888-8801 or 800-952-2740
E-mail: commercial.warranty@toro.com

Owner Responsibilities

As the Product owner, you are responsible for required maintenance and adjustments stated in your *Operator's Manual*. Failure to perform required maintenance and adjustments can be grounds for disallowing a warranty claim.

Items and Conditions Not Covered

Not all product failures or malfunctions that occur during the warranty period are defects in materials or workmanship. This warranty does not cover the following:

- Product failures which result from the use of non-Toro replacement parts, or from installation and use of add-on, or modified non-Toro branded accessories and products. A separate warranty may be provided by the manufacturer of these items.
- Product failures which result from failure to perform recommended maintenance and/or adjustments. Failure to properly maintain your Toro product per the Recommended Maintenance listed in the *Operator's Manual* can result in claims for warranty being denied.
- Product failures which result from operating the Product in an abusive, negligent, or reckless manner.
- Parts subject to consumption through use unless found to be defective. Examples of parts which are consumed, or used up, during normal Product operation include, but are not limited to, brake pads and linings, clutch linings, blades, reels, rollers and bearings (sealed or greasable), bed knives, spark plugs, castor wheels and bearings, tires, filters, belts, and certain sprayer components such as diaphragms, nozzles, and check valves, etc.
- Failures caused by outside influence. Conditions considered to be outside influence include, but are not limited to, weather, storage practices, contamination, use of unapproved fuels, coolants, lubricants, additives, fertilizers, water, or chemicals, etc.
- Failure or performance issues due to the use of fuels (e.g. gasoline, diesel, or biodiesel) that do not conform to their respective industry standards.

Countries Other than the United States or Canada

Customers who have purchased Toro products exported from the United States or Canada should contact their Toro Distributor (Dealer) to obtain guarantee policies for your country, province, or state. If for any reason you are dissatisfied with your Distributor's service or have difficulty obtaining guarantee information, contact the Toro importer.

- Normal noise, vibration, wear and tear, and deterioration.
- Normal "wear and tear" includes, but is not limited to, damage to seats due to wear or abrasion, worn painted surfaces, scratched decals or windows, etc.

Parts

Parts scheduled for replacement as required maintenance are warranted for the period of time up to the scheduled replacement time for that part. Parts replaced under this warranty are covered for the duration of the original product warranty and become the property of Toro. Toro will make the final decision whether to repair any existing part or assembly or replace it. Toro may use remanufactured parts for warranty repairs.

Deep Cycle and Lithium-Ion Battery Warranty:

Deep cycle and Lithium-Ion batteries have a specified total number of kilowatt-hours they can deliver during their lifetime. Operating, recharging, and maintenance techniques can extend or reduce total battery life. As the batteries in this product are consumed, the amount of useful work between charging intervals will slowly decrease until the battery is completely worn out. Replacement of worn out batteries, due to normal consumption, is the responsibility of the product owner. Battery replacement may be required during the normal product warranty period at owner's expense. Note: (Lithium-Ion battery only): A Lithium-Ion battery has a part only prorated warranty beginning year 3 through year 5 based on the time in service and kilowatt hours used. Refer to the *Operator's Manual* for additional information.

Maintenance is at Owner's Expense

Engine tune-up, lubrication, cleaning and polishing, replacement of filters, coolant, and completing recommended maintenance are some of the normal services Toro products require that are at the owner's expense.

General Conditions

Repair by an Authorized Toro Distributor or Dealer is your sole remedy under this warranty.

Neither The Toro Company nor Toro Warranty Company is liable for indirect, incidental or consequential damages in connection with the use of the Toro Products covered by this warranty, including any cost or expense of providing substitute equipment or service during reasonable periods of malfunction or non-use pending completion of repairs under this warranty. Except for the Emissions warranty referenced below, if applicable, there is no other express warranty. All implied warranties of merchantability and fitness for use are limited to the duration of this express warranty.

Some states do not allow exclusions of incidental or consequential damages, or limitations on how long an implied warranty lasts, so the above exclusions and limitations may not apply to you. This warranty gives you specific legal rights, and you may also have other rights which vary from state to state.

Note regarding engine warranty:

The Emissions Control System on your Product may be covered by a separate warranty meeting requirements established by the U.S. Environmental Protection Agency (EPA) and/or the California Air Resources Board (CARB). The hour limitations set forth above do not apply to the Emissions Control System Warranty. Refer to the Engine Emission Control Warranty Statement supplied with your product or contained in the engine manufacturer's documentation for details