



**Count on it.**

**Parts Catalog**

**18in Dethatcher**

Model No. 23513—Serial No. 314000001 and Up

Model No. 33513—Serial No. 314000001 and Up



# Ordering Replacement Parts

To order replacement parts, please supply the part number, the quantity, and the description of each part desired.

## Understanding Reference Numbers

Each identified part in an illustration has a reference number. The reference number for a part also appears in the parts list, along with other information about the part.

This catalog uses two special reference number formats, one to indicate parts in a service assembly and another to indicate the quantity of a given part in an illustration.

## Service Assembly Reference Numbers

Parts in service assemblies have reference numbers in the form a:b. The a represents the reference number of the entire service assembly and the b represents a sequential number unique to each part within the service assembly.

For example, a wheel assembly might be identified by reference number 6, the tire by 6:1, the valve by 6:2, and the wheel by 6:3. When you order the assembly identified by reference number 6, you receive all parts identified by reference numbers 6:1, 6:2, and 6:3. However, you may also order any part individually. Reference numbers of this type appear in illustration and in parts lists.

## Reference Numbers Indicating Quantity

In an illustration, if a reference number indicates more than one part, the reference number has the form nX y. The n represents the quantity of the part, the X is the multiplication symbol, and the y represents the reference number.

For example, in an illustration, the reference number 2X 37 means that two of the parts identified by reference number 37 are indicated.

# List of Abbreviations

**AR:** as required

**ASM:** assembly

**BBC:** blade brake control

**BHTF:** button head thread forming

**CARR:** carriage

**CCW:** counter clockwise

**CW:** clockwise

**DEG:** degrees

**DPA:** Dual Point Adjustment

**ECM:** electronic control module

**EXT:** external

**FH:** flat head

**GA:** gauge

**HD:** heavy-duty

**HF:** hex flange

**HH:** hex head

**HHF:** hex head flange

**HHFTF:** hex head flange thread forming

**HJ:** hex jam

**HLH:** hex lag head

**HOC:** height-of-cut

**HP:** high pressure

**HSBH:** hex socket button head

**HSFH:** hex socket flat head

**HSH:** hex socket head

**HWH:** hex washer head

**HWHTF:** hex washer head thread forming

**HYD:** hydraulic

**LH:** left hand

**LP:** low pressure

**LPG:** Liquefied Petroleum Gas

**NI:** nylon insert

**NPTF:** national pipe thread fine

**PFH:** phillips flat head

**PPH:** phillips pan head

**PPHTF:** phillips pan head thread forming

**PRH:** phillips round head

**PTH:** phillips truss head

**PTO:** power-take-off

**RH:** right hand

**ROPS:** roll-over protection system

**RRB:** rear roller brush

**SFH:** slotted fillister head

**SHH:** slotted hex head

**SHWH:** slotted hex washer head

**SPH:** slotted pan head

**SQH:** square head

**SRH:** slotted round head

**STD:** standard

**TAP:** self tapping

**TTH:** torx truss head

# Contents

Frame and Engine Assembly .....	4
Handle Assembly .....	6
Bearing and Shaft Assembly .....	8
Transport-Wheel Assembly.....	10
Belt Guard Assembly .....	12

# Frame and Engine Assembly

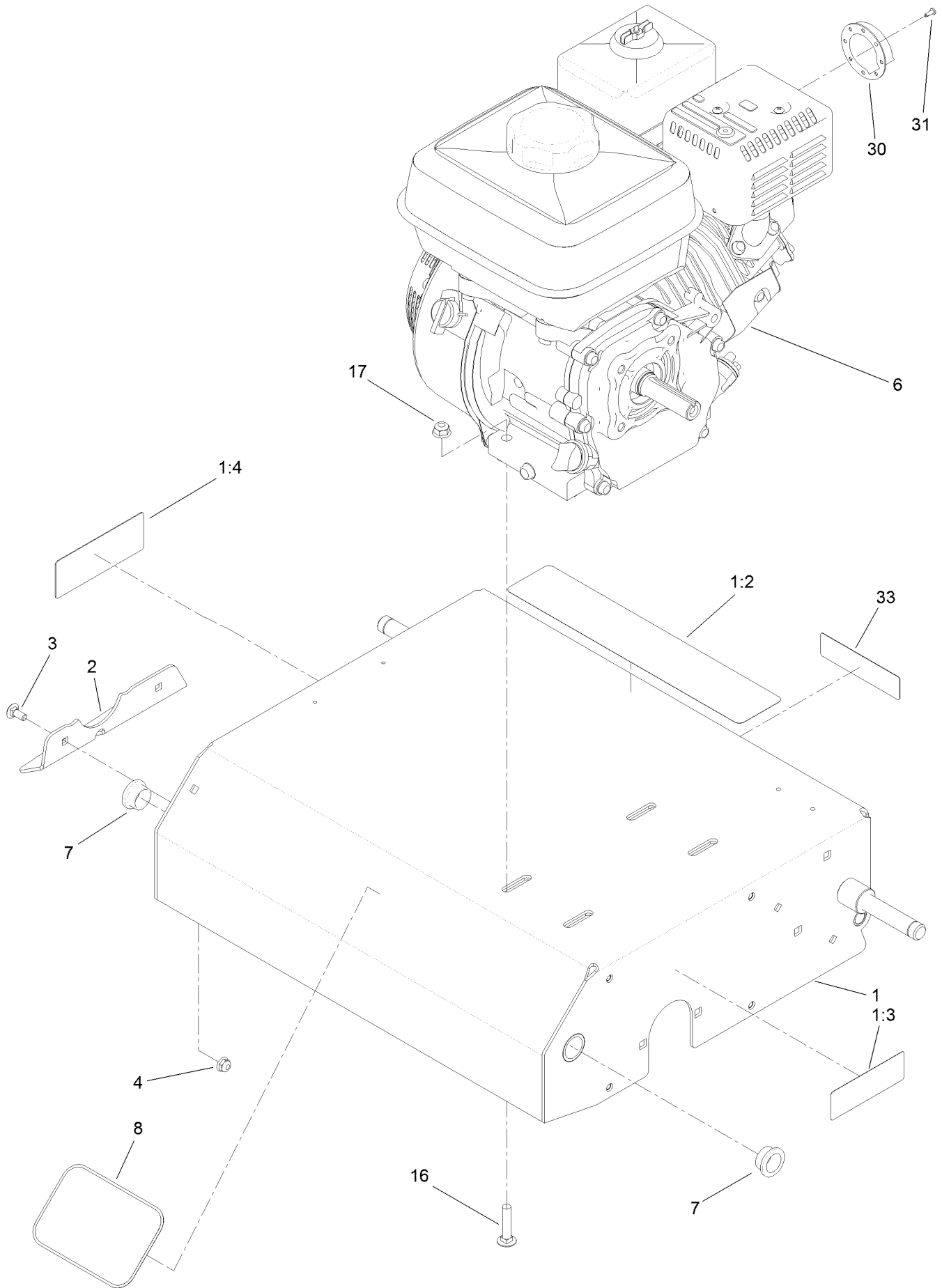

## Frame and Engine Assembly (continued)

<i>Ref.</i>	<i>Part Number</i>	<i>Qty.</i>	<i>Description</i>	<i>Ref.</i>	<i>Part Number</i>	<i>Qty.</i>	<i>Description</i>
1	125-3825	1	Frame ASM	7	121-1876	2	Bushing
1:2	125-3809	1	Decal-Warning	8	67-1300	1	Decal
1:3	117-4979	1	Decal-Warning, Shields	16	3230-4	4	Screw-CARR
1:4	93-7321	1	Decal-Danger	17	104-8300	4	Nut-Flange, NI
2	121-1853-01	1	Guard-Hand	30	125-3866	1	Deflector
3	3229-11	2	Screw-CARR	31	120-1884	2	Screw-PPHTF
4	104-7201	2	Nut-HF	33	117-2718	1	Decal-Arrester, Spark
6	125-4813	1	Engine-Honda, Gx160				

# Handle Assembly

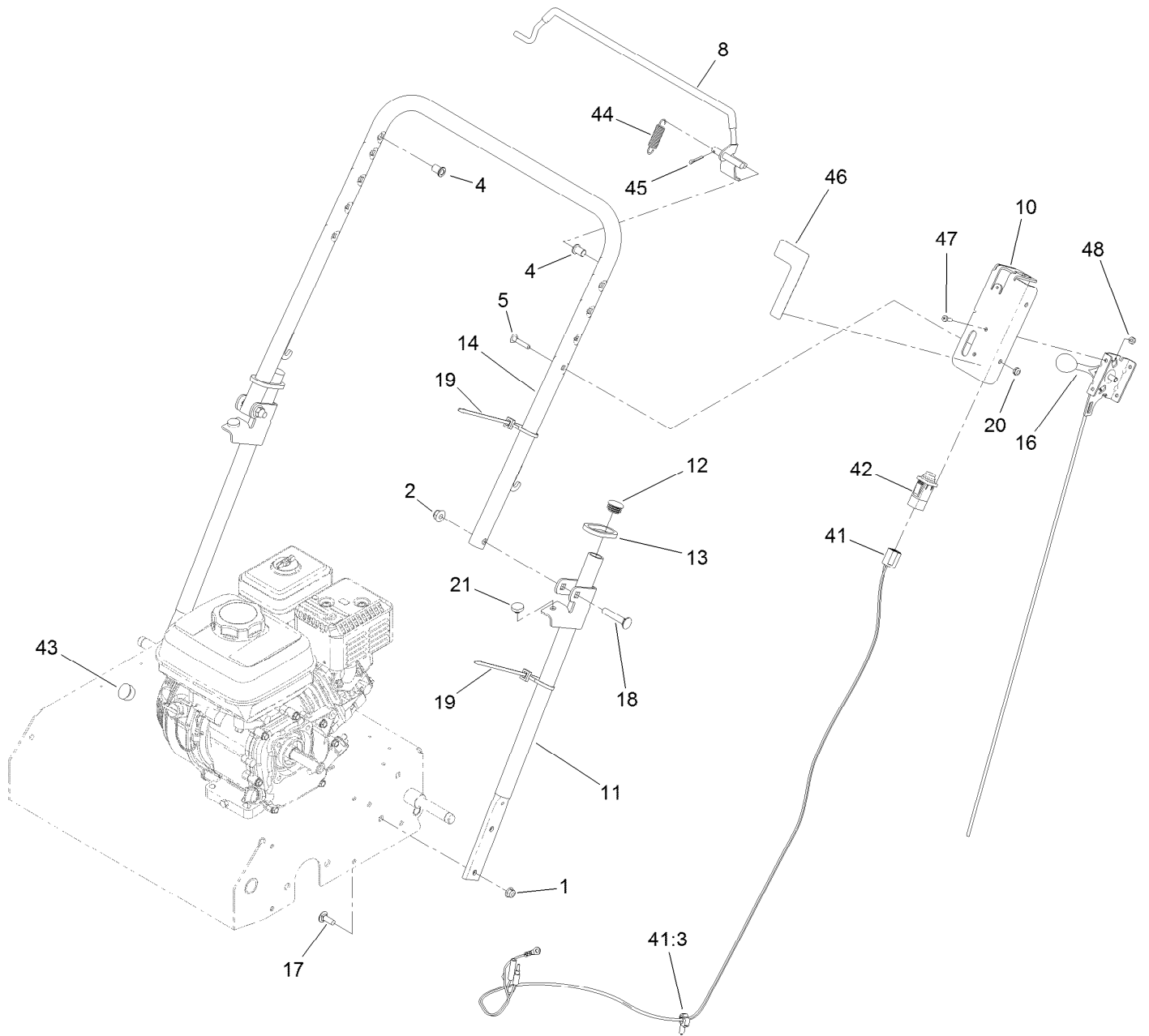

## Handle Assembly (continued)

<i>Ref.</i>	<i>Part Number</i>	<i>Qty.</i>	<i>Description</i>	<i>Ref.</i>	<i>Part Number</i>	<i>Qty.</i>	<i>Description</i>
1	104-8300	4	Nut-Flange, NI	19	3290-378	2	Tie-Cable
2	104-8301	2	Nut-Flange, NI	20	3296-56	2	Nut-Lock, NI
4	109-2713	2	Bushing	21	1-513658	2	Bumper
5	109-8144	2	Bolt-Handle	41	127-4042	1	Harness-Wire
8	127-4026	1	Bail	41:3	32180-037	1	Clip-Harness
10	127-4027-03	1	Bracket-Throttle	42	100-1268	1	Switch-Plunger
11	125-3621-03	2	Handle	43	120-1887	1	Plug-Engine
12	121-4870	2	Plug	44	121-4409	1	Spring-Extension
13	121-6202	2	Ring-Handle Lock	45	3272-10	1	Pin-Cotter
14	125-3800-03	1	Handle-Upper	46	127-4061	1	Decal-Throttle
16	127-4048	1	Cable-Throttle	47	3290-500	2	Screw-PPH
17	3230-10	4	Screw-CARR	48	3296-2	2	Nut-Lock, NI
18	3231-6	2	Screw-CARR				

# Bearing and Shaft Assembly

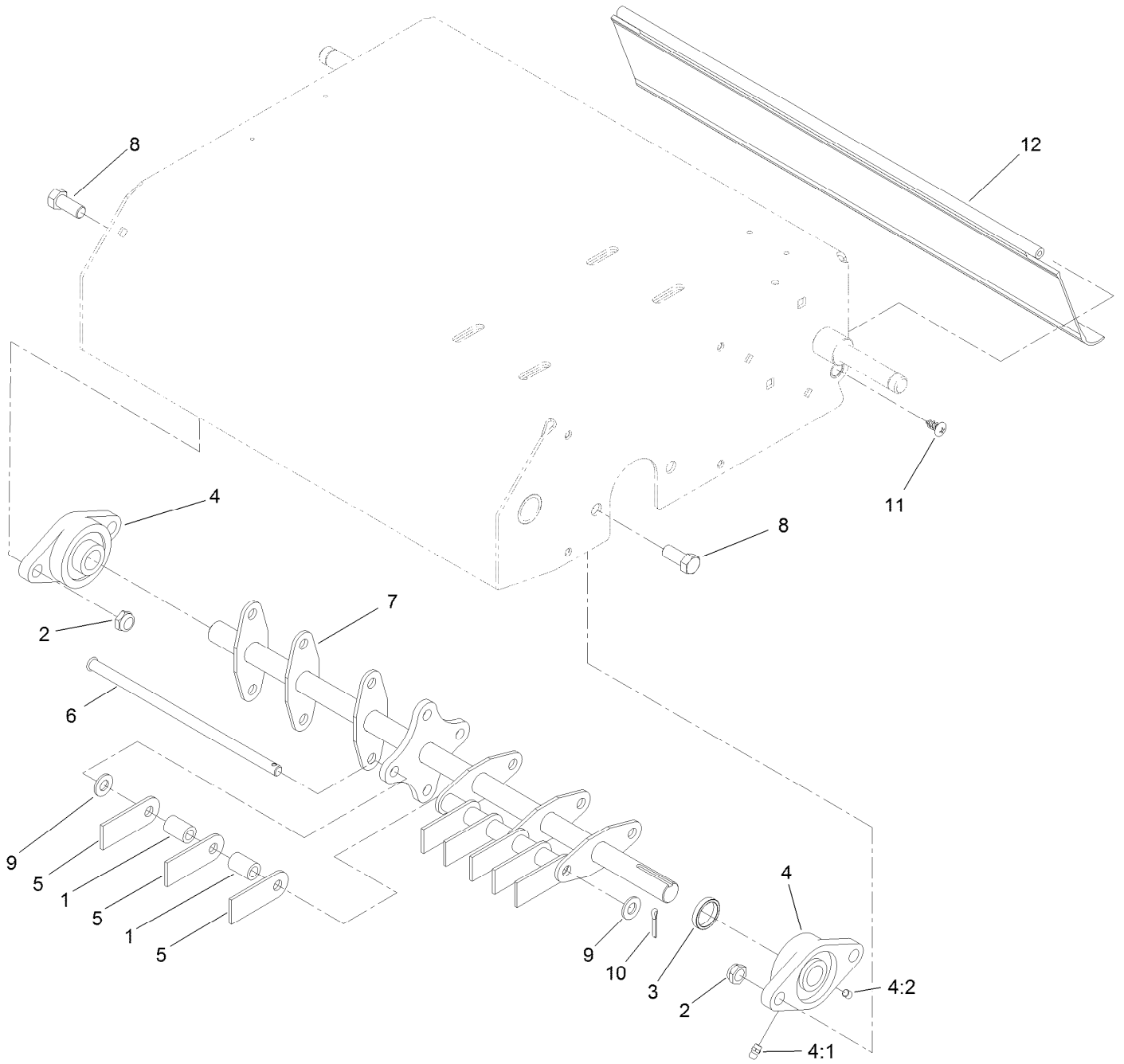



## Bearing and Shaft Assembly (continued)

<i>Ref.</i>	<i>Part Number</i>	<i>Qty.</i>	<i>Description</i>	<i>Ref.</i>	<i>Part Number</i>	<i>Qty.</i>	<i>Description</i>
1	125-3870	28	Spacer	6	121-6208	4	Shaft-Satellite
2	3296-38	4	Nut-Lock, NI	7	121-6220-03	1	Shaft-Rake
3	116-5805	1	Collar	8	3212-4	4	Screw-HH
4	106-7126	2	Bearing-Flange	9	3256-24	8	Washer-Flat
4:1	302-58	1	Fitting-Straight	10	3272-10	4	Pin-Cotter
4:2	3245-35	2	Screw-Set, HSH	11	117-1092	2	Screw-PTH
5	121-1869	32	Blade-Flail	12	120-6241	1	Shield-Trailing

# Transport-Wheel Assembly

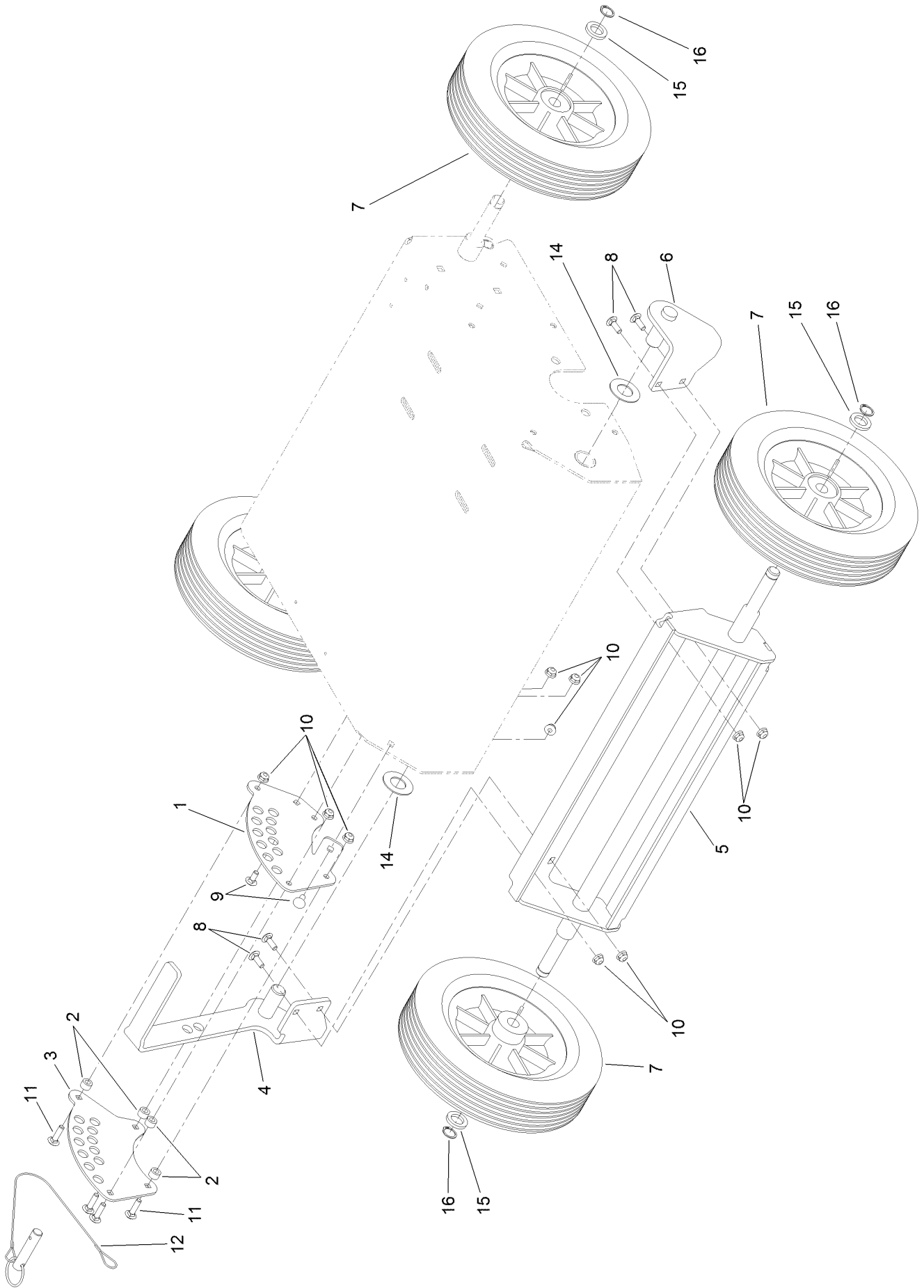

## Transport-Wheel Assembly (continued)

<i>Ref.</i>	<i>Part Number</i>	<i>Qty.</i>	<i>Description</i>	<i>Ref.</i>	<i>Part Number</i>	<i>Qty.</i>	<i>Description</i>
1	121-1854	1	Bracket	9	3229-11	2	Screw-CARR
2	98-4799	4	Spacer	10	104-7201	10	Nut-HF
3	121-1856	1	Plate	11	3229-2	4	Screw-CARR
4	125-3599-03	1	Bracket-Adjust, Height	12	104-3678	1	Pin-Hitch
5	125-3626-03	1	Bracket-Wheel, HOC	14	3256-39	2	Washer-Flat
6	125-3600-03	1	Bracket-Wheel	15	63-9710	4	Spacer-Bearing
7	121-4897	4	Wheel-Transport	16	32120-64	4	Ring-Snap, External
8	3229-1	4	Bolt-CARR				

# Belt Guard Assembly

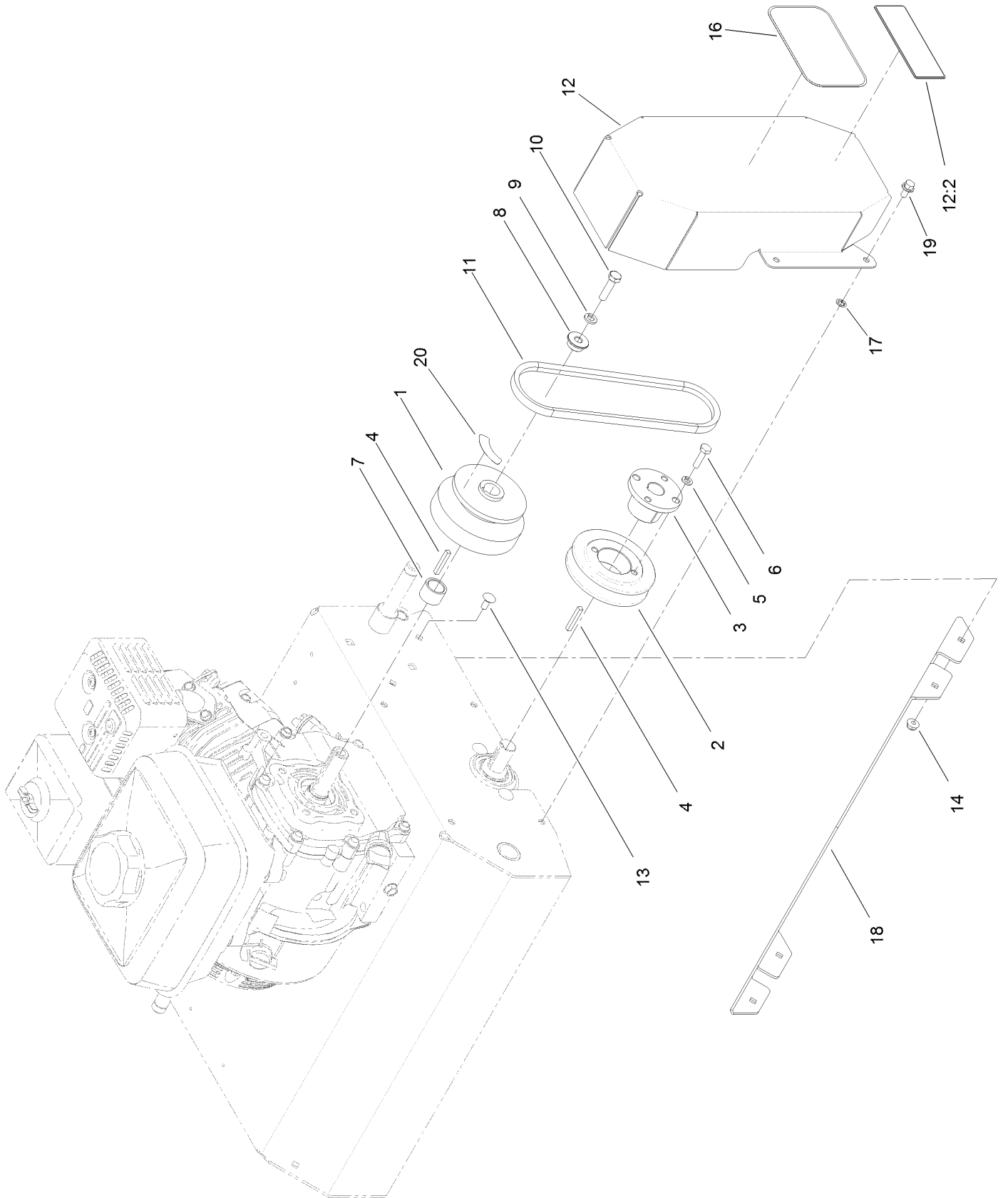

## Belt Guard Assembly (continued)

<i>Ref.</i>	<i>Part Number</i>	<i>Qty.</i>	<i>Description</i>	<i>Ref.</i>	<i>Part Number</i>	<i>Qty.</i>	<i>Description</i>
1	120-1215	1	Clutch-Centrifugal	11	53-4650	1	V-Belt
2	121-2019	1	Sheave-Taper Lock	12	125-3827	1	Belt Guard ASM
3	121-2022	1	Bushing-Taper Lock	12:2	93-7321	1	Decal-Danger
4	92-2649	2	Key-Square	13	3229-11	4	Screw-CARR
5	3253-3	2	Washer-Lock	14	104-7201	4	Nut-HF
6	321-6	2	Screw-HH	16	67-1300	1	Decal
7	121-7731	1	Spacer	17	1-803037	4	Nut-Retaining
8	121-7732	1	Bushing	18	121-6235-01	1	Baffle-Deflector
9	3253-4	1	Washer-Lock	19	3234-13	4	Screw-HHF
10	3210-6	1	Screw-HH	20	125-3897	1	Decal-Warning

**Notes:**

**Notes:**



**Count on it.**