



Count on it.

Operator's Manual

**72in Side Discharge Mower
Groundsmaster® 300 Series Traction Unit**

Model No. 30722—Serial No. 315000001 and Up



▲ WARNING

**CALIFORNIA
Proposition 65 Warning**

This product contains a chemical or chemicals known to the State of California to cause cancer, birth defects, or reproductive harm.

This product complies with all relevant European directives; for details, please see the separate product specific Declaration of Conformity (DOC) sheet.



Figure 1

1. Safety alert symbol

This manual uses 2 words to highlight information.

Important calls attention to special mechanical information and **Note** emphasizes general information worthy of special attention.

Introduction

This rotary-blade lawn cutting deck is mounted to a ride-on machine and is intended to be used by professional, hired operators in commercial applications. It is primarily designed for cutting grass on well-maintained lawns in parks, sports fields, and on commercial grounds. It is not designed for cutting brush, mowing grass and other growth alongside highways, or for agricultural uses.

Read this information carefully to learn how to operate and maintain your product properly and to avoid injury and product damage. You are responsible for operating the product properly and safely.

You may contact Toro directly at www.Toro.com for product and accessory information, help finding a dealer, or to register your product.

Whenever you need service, genuine Toro parts, or additional information, contact an Authorized Service Dealer or Toro Customer Service and have the model and serial numbers of your product ready. The model and serial numbers are stamped into a plate that is mounted on the rear of the mower deck (just ahead of the left rear castor wheel). Write the numbers in the space provided.

Model No. _____
Serial No. _____

This manual identifies potential hazards and has safety messages identified by the safety alert symbol (Figure 1), which signals a hazard that may cause serious injury or death if you do not follow the recommended precautions.

Contents

Safety	3
Safe Operating Practices	3
Toro Mower Safety	4
Safety and Instructional Decals	5
Setup	7
1 Installing the Castor Wheel Assemblies	8
2 Lowering the Grass Deflector	8
3 Installing the Ball Joints and Connecting the Lift Cylinder.....	8
4 Installing the Drive Shaft to the Traction Unit	9
5 Connecting the Right-Hand Push Arm to the Cutting Unit.....	10
6 Connecting the Left-Hand Push Arm to the Cutting Unit.....	10
7 Connecting the Drive Shaft to the Cutting Unit Gear Box	11
8 Installing the Lift Chains	12
9 Greasing the Machine	12
10 Installing the Rear Weight	12
Product Overview	13
Specifications	13
Attachments/Accessories.....	13
Operation	14
Checking the Lubricant in the Gear Box.....	14
Adjusting the Height-of-Cut	14
Adjusting the Rollers.....	15
Using the Grass Deflector	15
Operating Tips	15
Maintenance	17
Recommended Maintenance Schedule(s)	17
Lubricating.....	18
Separating the Cutting Unit from the Traction Unit	18
Mounting the Cutting Unit to the Traction Unit	20
Replacing the Blade Drive Belts	20
Servicing the Bushings in the Castor Arms	20
Servicing the Castor Wheels and Bearings	21
Removing and Installing the Blade(s).....	21
Inspecting and Sharpening the Blade(s).....	22
Checking and Correcting Mismatched Blades	23
Troubleshooting	24

Safety

This machine has been designed in accordance with EN ISO 5395:2013 and ANSI B71.4-2012.

Improper use or maintenance by the operator or owner can result in injury. To reduce the potential for injury, comply with these safety instructions and always pay attention to the safety alert symbol (**Figure 1**), which means Caution, Warning, or Danger—personal safety instruction. Failure to comply with the instruction may result in personal injury or death.

Safe Operating Practices

Training

- Read the *Operator's Manual* and other training material carefully. If the operator or mechanic can not read the language of this manual, it is the owner's responsibility to explain this material to them.
- Become familiar with the safe operation of the equipment, operator controls, and safety signs.
- All operators and mechanics should be trained. The owner is responsible for training the users
- Never let children or untrained people operate or service the equipment. Local regulations may restrict the age of the operator.
- The owner/user can prevent and is responsible for accidents or injuries occurring to himself or herself, other people, or property.

Preparation

- Evaluate the terrain to determine what accessories and attachments are needed to properly and safely perform the job. Only use accessories and attachments approved by the manufacturer.
- Wear appropriate clothing including hard hat, safety glasses and ear protection. Long hair, loose clothing or jewelry may get tangled in moving parts.
- Inspect the area where the equipment is to be used and remove all objects such as rocks, toys and wire which can be thrown by the machine.
- Use extra care when handling gasoline and other fuels. They are flammable and vapors are explosive.
 - Use only an approved container.
 - Never remove fuel cap or add fuel with engine running. Allow engine to cool before refueling. Do not smoke.
 - Never refuel or drain the machine indoors.
- Check that operator's presence controls, safety switches, and shields are attached and functioning properly. Do not operate unless they are functioning properly.

Operation

- Never run an engine in an enclosed area.

- Only operate in good light, keeping away from holes and hidden hazards.
- Be sure all drives are in neutral and parking brake is engaged before starting the engine. Only start the engine from the operator's position. Use seat belts if provided.
- Slow down and use extra care on hillsides. Be sure to travel in the recommended direction on hillsides. Turf conditions can affect the machine's stability. Use caution while operating near drop-offs.
- Slow down and use caution when making turns and when changing directions on slopes.
- Never raise the deck with the blades running.
- Never operate with guards not securely in place. Be sure all interlocks are attached, adjusted properly, and functioning properly.
- Do not change the engine governor setting or overspeed the engine.
- Stop on level ground, lower the cutting units, disengage drives, engage parking brake (if provided), shut off engine before leaving the operator's position for any reason.
- Stop equipment and inspect the blades after striking objects or if an abnormal vibration occurs. Make necessary repairs before resuming operations.
- Keep hands and feet away from the cutting units.
- Look behind and down before backing up to be sure of a clear path.
- Never carry passengers and keep pets and bystanders away.
- Slow down and use caution when making turns and crossing roads and sidewalks. Stop blades if not mowing.
- Do not operate the mower under the influence of alcohol or drugs.
- Lightning can cause severe injury or death. If lightning is seen or thunder is heard in the area, do not operate the machine; seek shelter.
- Use care when loading or unloading the machine into a trailer or truck.
- Use care when approaching blind corners, shrubs, trees, or other objects that may obscure vision.
- The operator shall turn on flashing warning lights, if provided, whenever traveling on a public road, except where such use is prohibited by law.
- Let engine cool before storing and do not store near flame.
- Shut off fuel while storing or transporting. Do not store fuel near flames or drain indoors.
- Park machine on level ground. Never allow untrained personnel to service machine.
- Use jack stands to support components when required.
- Carefully release pressure from components with stored energy.
- Disconnect battery before making any repairs. Disconnect the negative terminal first and the positive last. Reconnect positive first and negative last.
- Use care when checking blades. Wrap the blades or wear gloves, and use caution when servicing them. Only replace blades. Never straighten or weld them.
- Keep hands and feet away from moving parts. If possible, do not make adjustments with the engine running.
- Charge batteries in an open well ventilated area, away from spark and flames. Unplug charger before connecting or disconnecting from battery. Wear protective clothing and use insulated tools.
- Keep all parts in good working condition and all hardware tightened. Replace all worn or damaged decals.

Maintenance and Storage

- Disengage drives, lower the cutting units, move traction pedal to Neutral, set parking brake, stop engine and remove key. Wait for all movement to stop before adjusting, cleaning or repairing.
- Clean grass and debris from cutting units, drives, muffler. Let engine cool before storing and do not store near flames, and engine to help prevent fires. Clean up oil or fuel spillage.
- Know how to stop the engine quickly.
- Do not operate the machine while wearing tennis shoes or sneakers.
- Wearing safety shoes and long pants is advisable and required by some local ordinances and insurance regulations.
- Handle fuel carefully. Wipe up any spills.
- Check the safety interlock switches daily for proper operation. If a switch should fail, replace the switch before operating the machine.
- Using the machine demands attention. To prevent loss of control:
 - Do not drive close to sand traps, ditches, creeks, embankments, or other hazards.
 - Avoid sudden stops and starts.
 - When near or crossing roads, always yield the right-of-way.

Toro Mower Safety

The following list contains safety information specific to Toro products or other safety information that you must know that is not included in the CEN, ISO, or ANSI standard.

This product is capable of amputating hands and feet and throwing objects. Always follow all safety instructions to avoid serious injury or death.

Use of this product for purposes other than its intended use could prove dangerous to user and bystanders.

- Lower the cutting unit when going down slopes.
- The grass deflector must always be installed and in the lowest position on the side discharge cutting unit. Never operate the mower without the deflector or entire grass collector.
- If the cutting unit discharge area ever plugs, shut the engine off before removing the obstruction.
- Cut grass slopes carefully. Do not start, stop, or turn suddenly.
- Do not touch the engine or muffler while the engine is running or soon after it has stopped because these areas could be hot enough to cause burns.

relieved by stopping the engine and lowering the cutting units to the ground.

- If the engine must be running to perform a maintenance adjustment, keep hands, feet, clothing, and any parts of the body away from the cutting units, attachments, and any moving parts. Keep everyone away.
- Do not overspeed the engine by changing governor settings. To ensure safety and accuracy, have an Authorized Toro Distributor check the maximum engine speed with a tachometer.
- The engine must be shut off before checking the oil or adding oil to the crankcase.
- Make sure that the mower fuel tank is empty if the machine is to be stored in excess of 30 days. Do not store the mower near any open flame or where gasoline fumes may be ignited by a spark.
- Perform only those maintenance instructions described in this manual. If major repairs are ever needed or if assistance is desired, contact an Authorized Toro Distributor.
- To make sure of optimum performance and continued safety certification of the machine, use only genuine Toro replacement parts and accessories. Replacement parts and accessories made by other manufacturers could be dangerous, and such use could void the product warranty.

Maintenance and Storage

- Check the blade mounting bolts frequently to be sure that they are tightened to specification.
- Make sure that all hydraulic line connectors are tight and all hydraulic hoses and lines are in good condition before applying pressure to the system.
- Keep your body and hands away from pin hole leaks or nozzles that eject hydraulic fluid under high pressure. Use paper or cardboard, not your hands, to search for leaks. Hydraulic fluid escaping under pressure can have sufficient force to penetrate the skin and cause serious injury.
- Before disconnecting or performing any work on the hydraulic system, all pressure in the system must be

Safety and Instructional Decals



Safety decals and instructions are easily visible to the operator and are located near any area of potential danger. Replace any decal that is damaged or lost.

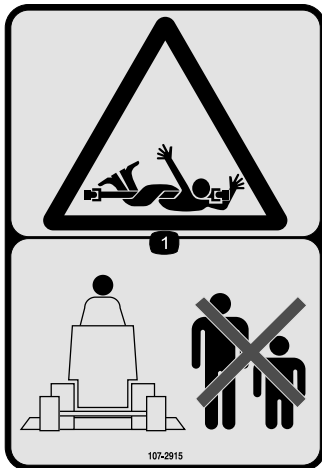

107-2915

1. Entanglement hazard, shaft—keep bystanders a safe distance from the machine.

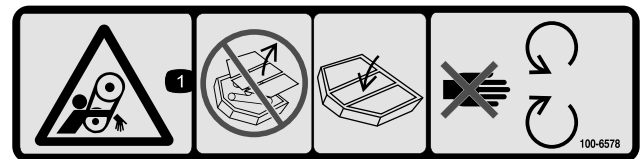

100-6578

1. Entanglement hazard, belt—do not operate the machine with the shields or guards removed; always keep the shields and guards in place; stay away from moving parts.



93-6697

1. Read the *Operator's Manual*.
2. Add SAE 80w-90 (API GL-5) oil every 50 hours.

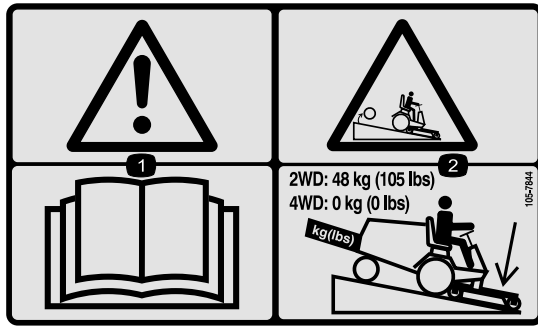

105-7844

1. Warning—read the *Operator's Manual*.
2. Rear wheel weight is required when operating a two-wheel drive Groundsmaster 328-D or Goundsmaster 345.

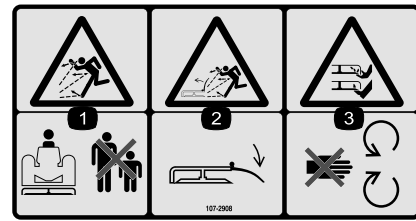

107-2908

1. Thrown object hazard—keep bystanders a safe distance from the machine.
2. Thrown object hazard—do not operate the mower with the deflector up or removed, keep the deflector in place.
3. Cutting/dismemberment hazard of hand or foot, mower blade—stay away from moving parts.

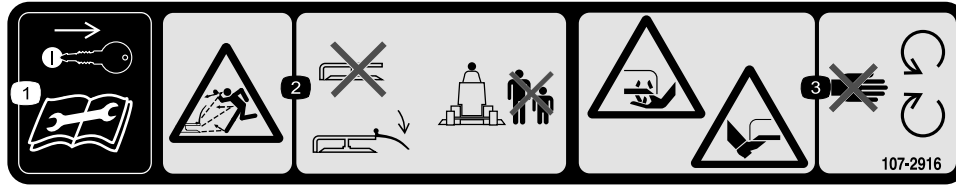

107-2916

1. Remove the ignition key and read the *Operator's Manual* before servicing or performing maintenance.
2. Thrown object hazard—do not operate the mower with the deflector up or removed, keep the deflector in place; keep bystanders a safe distance from the machine.
3. Cutting/dismemberment hazard of hand or foot, mower blade—stay away from moving parts.

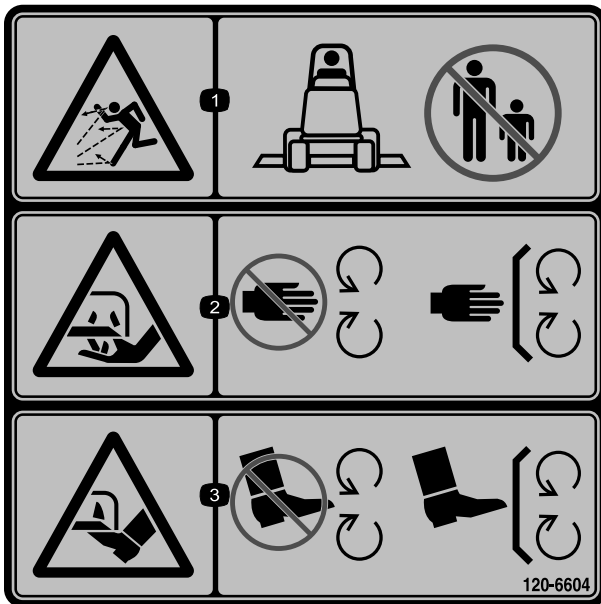

120-6604

1. Thrown object hazard—keep bystanders away from the machine.
2. Cutting/dismemberment hazard of hand, mower blade—stay away from moving parts, keep all guards and shields in place.
3. Cutting/dismemberment hazard of foot, mower blade—stay away from moving parts, keep all guards and shields in place.

Setup

Loose Parts

Use the chart below to verify that all parts have been shipped.

Procedure	Description	Qty.	Use
1	Large castor wheel assembly Small castor wheel assembly	2 2	Install the castor wheel assemblies.
2	No parts required	–	Lower the grass deflector.
3	No parts required	–	Install the ball joints and connect the lift cylinder.
4	Drive shaft	1	Install the drive shaft to the traction unit.
5	No parts required	–	Connect the right-hand push arm to the cutting unit.
6	No parts required	–	Connect the left-hand push arm to the cutting unit.
7	Bolt, 5/16 x 1-3/4 inches Locknut, 5/16 inches Roll pin, 3/16 x 1-1/2 inches	2 2 2	Connect the drive shaft to the cutting unit gear box.
8	No parts required	–	Install the lift chains.
9	No parts required	–	Grease the machine.
10	No parts required	–	Install rear weight.

Media and Additional Parts

Description	Qty.	Use
Parts Catalog	1	Review the material and save in an appropriate place.
Operator's Manual	1	

Note: Determine the left and right sides of the machine from the normal operating position.

1

Installing the Castor Wheel Assemblies

Parts needed for this procedure:

2	Large castor wheel assembly
2	Small castor wheel assembly

Procedure

The thrust washers, spacers, and tensioning caps have been installed on the castor wheel spindles for shipping.

1. Remove the tensioning caps from the spindle shafts and slide off the spacers and thrust washers (Figure 2 & Figure 3).

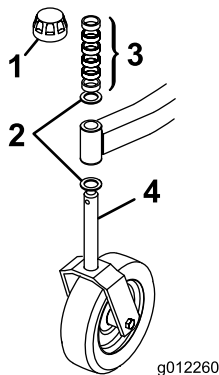

Figure 2

1. Tensioning cap
2. Thrust washers
3. Spacers
4. Large (front) castor spindle

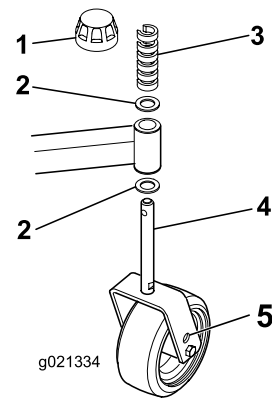

Figure 3

1. Tensioning cap
2. Thrust washers
3. Spacers
4. Small (rear) castor spindle

6. Ensure that all 4 castor wheels are set at the same height-of-cut; then roll the cutting unit off of the wooden pallet.

2

Lowering the Grass Deflector

No Parts Required

Procedure

Remove the shipping bands allowing the deflector to be lowered (Figure 4).

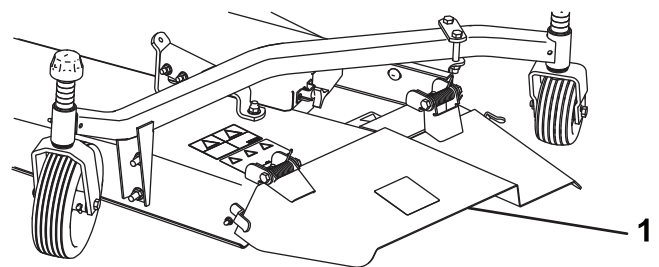

Figure 4

1. Grass deflector

2. Slide the spacers onto the castor spindle to get the desired height-of-cut; refer to the Height-of-Cut Chart in the [Adjusting the Height-of-Cut \(page 14\)](#) section in this manual.
3. Slide a thrust washer onto the spindle.
4. Push the large castor spindle through the front castor arm and the small castor spindle through the rear castor arm.
5. Install another thrust washer and the remaining spacers onto the spindle and install the tensioning cap to secure the assembly (Figure 2 and Figure 3).

Important: The thrust washers, not the spacers, must contact the top and bottom of the castor arm.

3

Installing the Ball Joints and Connecting the Lift Cylinder

No Parts Required

Procedure

Note: The ball joints are shipped with the traction unit.

1. Thread the jam nut fully onto the right-hand ball joint (Figure 5).
2. Screw the ball joint into the right-hand push arm until the center of the ball joint is 60 mm (2-3/8 inches) away from the front of the push arm (Fig. 9).

Note: Do not tighten the jam nut.

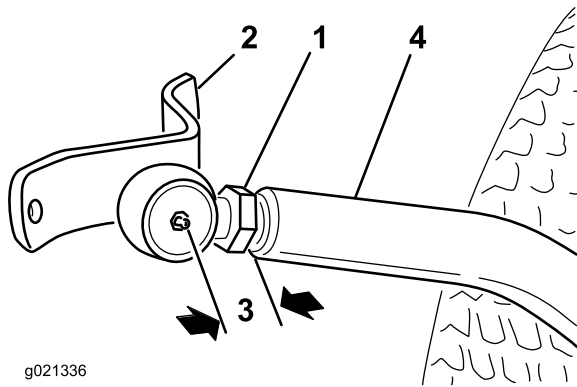

Figure 5

- | | |
|---------------------|------------------------|
| 1. Jam nut | 3. 60 mm (2-3/8 inch) |
| 2. Ball joint mount | 4. Right-hand push arm |

⚠ WARNING

Push arms are spring loaded. Sudden release of the push arms could cause injury.

Another person is required to push the arms down during installation of the ball joints or other implements.

3. Have another person push down on the left push arm.
4. Insert a 51 x 102 mm (2 x 4 inch) block of wood between the frame and the top of the push arm (Figure 6).
5. Screw the ball joint into the left-hand push arm until the center of the ball joint is 60 mm (2-3/8 inches) away from the front of the push arm (Figure 6).

Note: Do not tighten the jam nut.

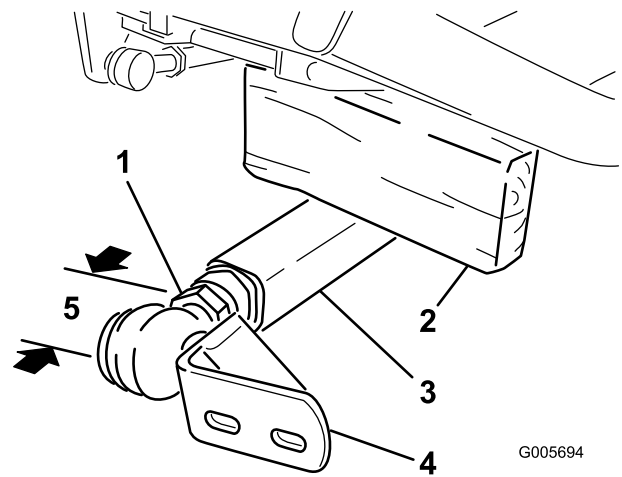

Figure 6

- | | |
|---|-------------------------|
| 1. Jam nut | 4. Ball joint mount |
| 2. 51 x 102 mm (2 x 4 inch) block of wood | 5. 60 mm (2-3/8 inches) |
| 3. Left-hand push arm | |

6. Carefully remove the 51 x 102 mm (2 x 4 inch) block of wood from between the frame and push arm.
7. Remove the spring pin from the cylinder pin and slide the cylinder pin out of the cylinder.
8. Raise the front of the lift arm until the hole in the movable end of the cylinder lines up with the holes in the lift arm brackets.

Note: Use caution as the lift arm is spring-loaded. Hold the parts together with the cylinder pin, spring pin, and cotter pin. The cotter pin must be to the outside.

4

Installing the Drive Shaft to the Traction Unit

Parts needed for this procedure:

1	Drive shaft
---	-------------

Procedure

Slide the smaller yoke end of the drive shaft onto the traction unit PTO shaft while aligning the mounting holes (Figure 7). Secure them with a roll pin. Do not install the front end of the drive shaft at this time.

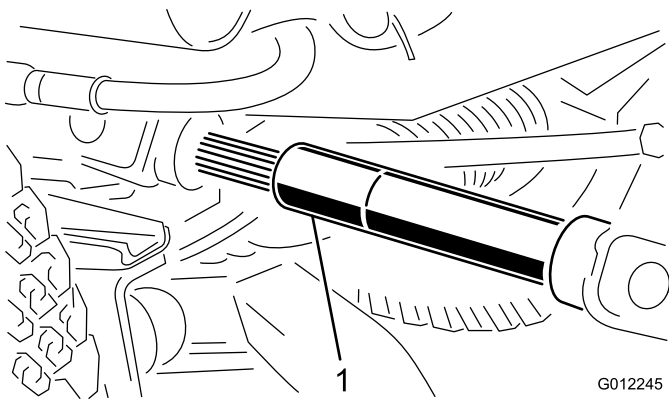

Figure 7

1. Drive shaft

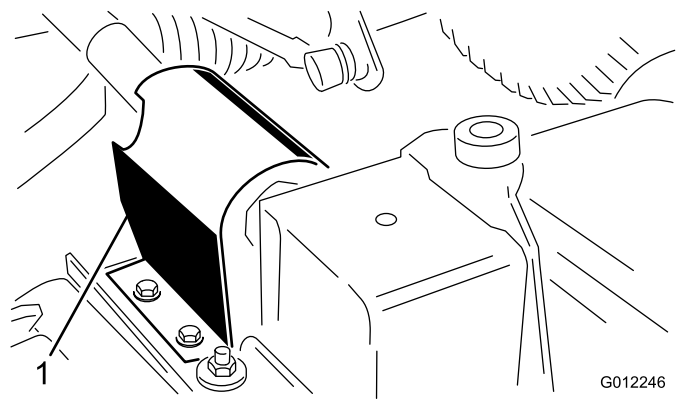

Figure 8

1. PTO shield

5

Connecting the Right-Hand Push Arm to the Cutting Unit

No Parts Required

Procedure

⚠ WARNING

The right-hand push arm is spring loaded to about 45 kg (100 lb.). Sudden release of the push arm could cause injury.

Another person is needed to push the arm down during this procedure.

1. Remove the bands securing the PTO shaft to the underside of the traction unit.
2. Remove the 2 self-tapping screws securing the PTO shield to the top of the cutting unit gear box mounting plate and remove the shield (Figure 8).

3. Move the cutting unit into position in front of the traction unit.
4. Have another person carefully push down on the push arm until the holes in the ball joint mount line up with the holes in the castor arm.

Note: Immediately slide a 4 x 4 inch block of wood between the top of the push arm and the underside of the chassis.
5. Secure the ball joint mount to the castor arm with (2) capscrews (7/16 x 3 inches), flat washers (7/16 inches), and flange nuts (7/16 inches).

Note: Position the capscrew head and the flat washers to the outside of the castor arm.

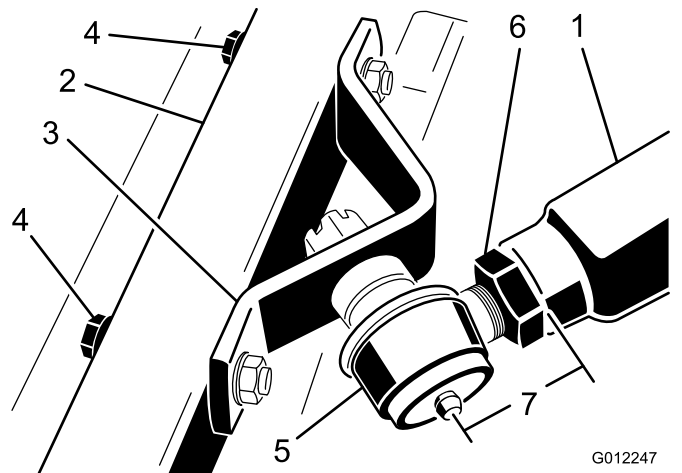

Figure 9

1. Right-hand push arm
2. Castor arm
3. Ball joint mount
4. Capscrews and washers
5. Ball joint
6. Jam nut
7. Flange nut

6. Tighten the large jam nut securing the ball joint to the push arm (Figure 9).

Note: When tightening the jam nut, hold the ball joint straight to permit proper oscillation during raising and lowering of the cutting unit. Carefully remove the wood block holding the push arm down.

6

Connecting the Left-Hand Push Arm to the Cutting Unit

No Parts Required

Procedure

⚠ WARNING

The left-hand push arm is spring loaded to about 68 kg (150 lb.). Sudden release of the push arm could cause injury.

Another person is needed to push the arm down during this procedure.

1. Remove the 2 capscrews, flat washers, and flange nuts securing the left-hand ball joint mount to the left-hand castor arm (Figure 10).

Note: Remove the ball joint mount and chain bracket.

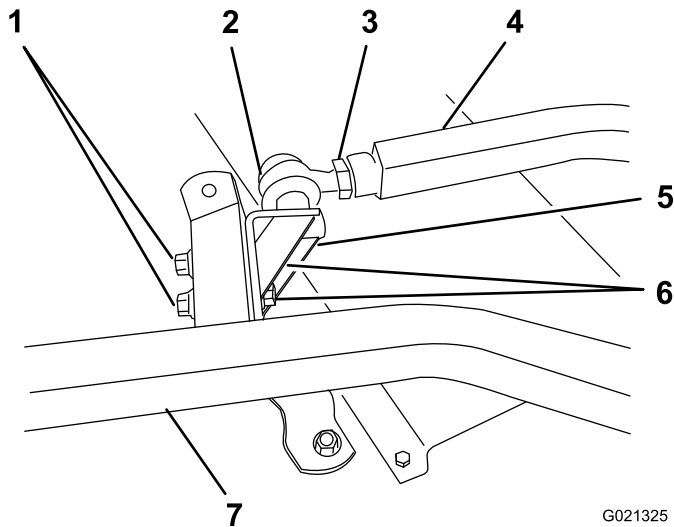

Figure 10

- | | |
|-----------------------|--------------------------|
| 1. Flange nuts | 5. Castor arm |
| 2. Ball joint | 6. Ball joint mount |
| 3. Jam nut | 7. Capscrews and washers |
| 4. Left-hand push arm | |

2. Have another person carefully push down on the push arm until the holes in the ball joint mount line up with the holes in the castor arm.

Note: Immediately slide a 102 x 102 mm (4 x 4 inch) block of wood between the top of the push arm and the underside of the chassis.

⚠ WARNING

Sudden release of the push arm could cause injury.

Make sure that the wooden block does not slip out.

3. Secure the ball joint mount to the castor arm with the capscrews, flat washers, and flange nuts previously removed.

Note: Position the capscrew heads and the flat washers to the outside of the castor arm.

4. Tighten the large jam nut securing the ball joint to the push arm.

Note: When tightening the jam nut, hold the ball joint straight to permit proper oscillation during raising and lowering of the cutting unit.

5. Carefully remove the wood block holding the push arm down.

7

Connecting the Drive Shaft to the Cutting Unit Gear Box

Parts needed for this procedure:

2	Bolt, 5/16 x 1-3/4 inches
2	Locknut, 5/16 inches
2	Roll pin, 3/16 x 1-1/2 inches

Procedure

Important: The drive shaft yokes must be exactly in line with each other when the outer yoke is installed on the gear box splined PTO shaft. Remove the sleeve and change the yoke position if the alignment is not correct. Misalignment of the two yokes will shorten the life of the drive shaft and cause unnecessary vibration when the cutting unit is operated.

1. Line up the holes in the yoke and input shaft of the gear box.
2. Slide the yoke onto the shaft and secure them together with a roll pin and 2 capscrews (5/16 x 1-3/4 inches) and locknuts (5/16 inch) (Figure 11).

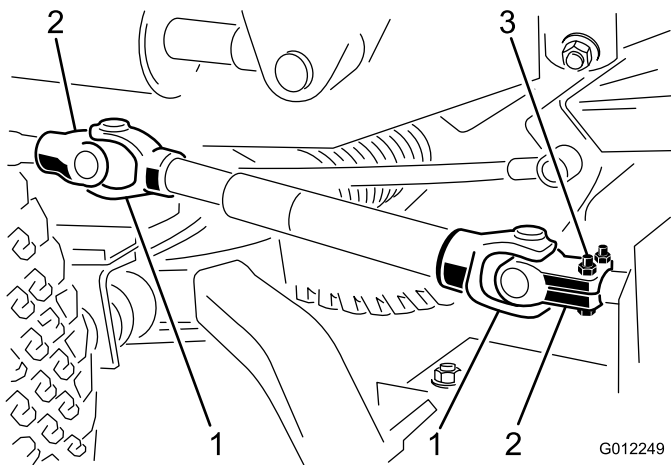

Figure 11

1. Drive shaft yokes
2. Yokes in phase
3. Roll pin and capscrow

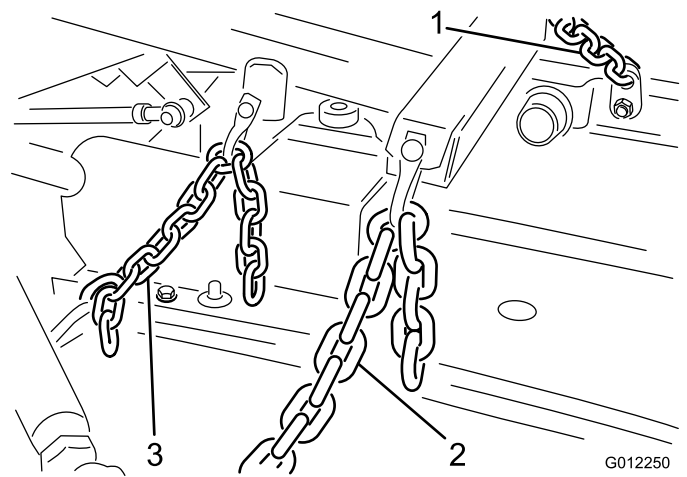

Figure 12

1. Front left lift chain
2. Front right lift chain
3. Rear lift chain

3. Mount the PTO shield to the top of the cutting unit gear box mounting plate with the 2 self-tapping screws previously removed.

2. Connect the ends of the tension spring between the fourth link of the rear chain and the eye of the cotter pin that holds the cylinder pin in place (Figure 12).

Note: Adjust the length of the chain so that the rear caster wheels are off of the ground in the transport position.

8

Installing the Lift Chains

No Parts Required

Procedure

1. Connect the lift chains to the lift arm and cutting unit chain brackets with 6 shackles, shackle pins (3/8 x 1-1/2 inches), and cotter pins (1/8 x 3/4 inch) (Figure 12).

Note: Adjust the chain length so that both become tight at the same time when lifting the lift arm.

9

Greasing the Machine

No Parts Required

Procedure

Before operating the machine, it must be greased to ensure proper lubricating characteristics; refer to Greasing the Bearings and Bushings. Failure to properly grease the machine will result in premature failure of critical parts.

10

Installing the Rear Weight

No Parts Required

Procedure

Two Wheel Drive Groundsmaster 300 Series Traction Units comply with the ANSI B71.4-2012 and EN:5395:2013 Standards when equipped with rear weight. Refer to chart in Traction Unit Operator's Manual to determine the

combinations of weight required. Order parts from your local Authorized Toro Distributor.

Four Wheel Drive Groundsmaster 300 Series Traction Units do not need additional rear weight to comply with the ANSI B71.4-2012 and EN:5395:2013 Standards.

Product Overview

Specifications

Note: Specifications and design are subject to change without notice.

Width of Cut	1.816 m (71-1/2 inches)
Height of Cut	Adjustable from 25 to 102 mm (1 to 4 inches) in 13 mm (1/2 inch) increments
Net Weight	226 kg. (499 lb)

Attachments/Accessories

A selection of Toro approved attachments and accessories is available for use with the machine to enhance and expand its capabilities. Contact your Authorized Service Dealer or Distributor or go to www.Toro.com for a list of all approved attachments and accessories.

Operation

Note: Determine the left and right sides of the machine from the normal operating position.

⚠ CAUTION

If you leave the key in the ignition switch, someone could accidentally start the engine and seriously injure you or other bystanders.

Remove the key from the ignition before you do any maintenance.

Checking the Lubricant in the Gear Box

Service Interval: Every 50 hours

The gear box is designed to operate on SAE 80–90 wt. gear lube. Although the gear box is shipped with lubricant from the factory, check the level before operating the cutting unit.

1. Position the machine and cutting unit on a level surface.
2. Remove the dipstick/fill plug from the top of the gear box (Figure 13) and make sure that the lubricant is between the marks on the dipstick. If the lubricant level is low, add enough lubricant until the level is between the marks.

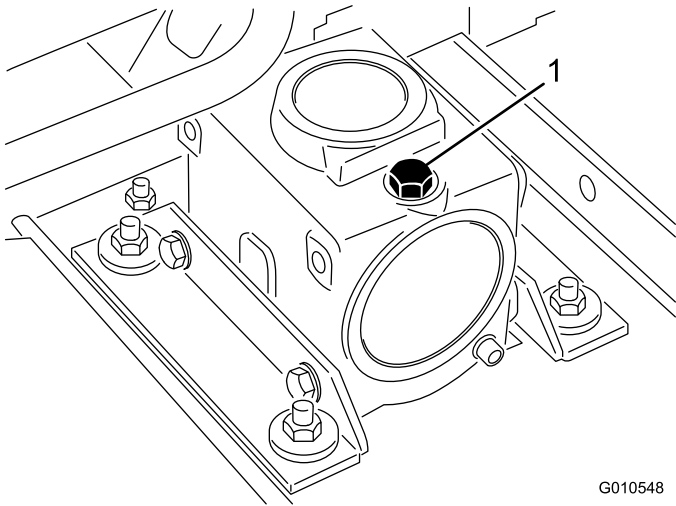

Figure 13

1. Dipstick/fill plug

Adjusting the Height-of-Cut

The height of cut is adjustable from 25 to 102 mm (1 to 4 inches) in 13 mm (1/2 inch) increments, by adding or removing an equal number of spacers from the front and rear castor forks. The height-of-cut chart below gives the combinations of spacers to use for all height-of-cut settings.

Height-of-Cut Setting	Spacers Below Castor Arm	
	Front	Rear
25 mm (1 inch)	0	0
38 mm (1–1/2 inches)	1	1
51 mm (2 inches)	2	2
64 mm (2–1/2 inches)	3	3
76 mm (3 inches)	4	4
89 mm (3–1/2 inches)	5	5
102 mm (4 inches)	6	6

Note: A more optimum cutting appearance of the turf can be achieved in the lower heights-of-cut by lowering the rear of the cutting unit. Accomplish this by relocating the rear castor wheel axles in the upper hole of the caster forks (Figure 14). Place the axles into the lower castor fork holes for higher height-of-cut settings where optimum cutting appearance is not required.

Important: Do not attempt to cut off more than 25 mm (1 inch) of the grass blades in the 25 mm (1 inch) height-of-cut setting with the rear of the cutting unit lowered, as this may cause the engine to labor excessively.

1. Start the engine and raise the cutting unit so that the front caster height-of-cut can be changed. Stop the engine after the cutting unit is raised. The rear castor height-of-cut can be changed with the cutting unit lowered.
2. Remove the tensioning cap from the spindle shaft. Slide the spacers onto the castor spindle to get the desired height-of-cut (Fig. 18 and 19). Then slide the washer (Figure 14) onto the spindle.
3. Push the castor spindle through the front castor arm, install the other thrust washer and remaining spacers onto the spindle, and install the tensioning cap to secure the assembly (Figure 14).

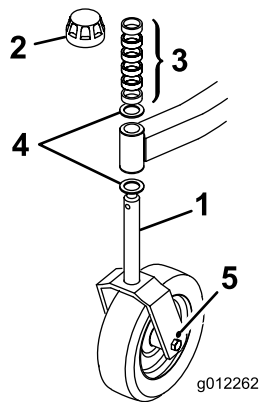

Figure 14

- | | |
|-------------------|-------------------|
| 1. Castor wheel | 4. Thrust washers |
| 2. Tensioning cap | 5. Upper hole |
| 3. Spacers | |

Adjusting the Rollers

Note: If the cutting unit is to be used in the 25 or 38 mm (1 or 1-1/2 inches) height-of-cut setting, the internal rollers must be repositioned in the top bracket holes.

1. Remove the cotter pins securing the roller shafts to the underside of the deck.

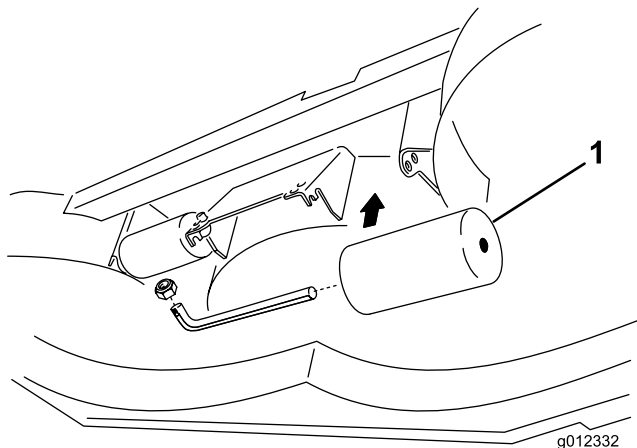

Figure 15

1. Internal rollers
2. Slide the shafts out of the lower bracket holes, align the rollers with the top holes, and install the shafts.
3. Install the cotter pins to secure the assemblies.

Using the Grass Deflector

⚠ DANGER

Without the grass deflector mounted in place, you and others are exposed to blade contact and thrown debris. Contact with the rotating mower blade(s) and thrown debris will cause injury or death.

- Never remove the grass deflector from the mower because the grass deflector routes material down toward the turf. If the grass deflector is ever damaged, replace it immediately.
- Never put your hands or feet under the mower.
- Never operate the mower with the deflector removed from the cutting unit or tied/blocked in a raised position.

Note: The deflector is spring loaded into its downward normal operating position, but the operator can temporarily swing it out of the way to facilitate loading in a trailer or when otherwise necessary.

Operating Tips

The use of protective equipment, such as but not limited to, for eyes, ears, feet, and head is recommended.

⚠ CAUTION

This machine produces sound levels in excess of 85 dBA at the operator's ear and can cause hearing loss through extended periods of exposure. Wear hearing protection when operating this machine.

Wear hearing protection when operating this machine.



Figure 16

1. Warning—wear hearing protection.

Mowing When Grass is Dry

Mow either in the late morning to avoid the dew, which causes grass clumping, or in late afternoon to avoid the damage that can be caused by direct sunlight on the sensitive, freshly mowed grass.

Selecting the Proper Height-of-Cut Setting to Suit Conditions

Remove approximately 26 mm (1 inch) or no more than 1/3 of the grass blade when cutting. In exceptionally lush and dense grass you may have to raise the height-of-cut setting another notch.

Mowing in Extreme Conditions

Air is required to cut and recut grass clippings in the mower housing, so do not set the height-of-cut too low or totally surround the housing by uncut grass. Always try to have one side of the mower housing free from uncut grass, allowing air to be drawn into the housing. When making an initial cut through the center of an uncut area, operate the machine slower and back up if the mower starts to clog.

Mowing with Sharp Blades

A sharp blade cuts cleanly and without tearing or shredding the grass blades like a dull blade. Tearing and shredding causes the grass to turn brown at the edges which impairs growth and increases susceptibility to diseases. Make sure that the blade is in good condition and a full sail is present.

Checking the Condition of the Deck

Make sure that the cutting chambers are in good condition. Straighten any bends in the chamber components to ensure correct blade tip/chamber clearance.

After Operating

To ensure optimum performance, clean the underside of the mower housing after each use. If residue is allowed to build up in the mower housing, cutting performance will decrease.

Maintenance

Recommended Maintenance Schedule(s)

Maintenance Service Interval	Maintenance Procedure
After the first 2 hours	<ul style="list-style-type: none">• Tighten the castor wheel nuts.
After the first 10 hours	<ul style="list-style-type: none">• Tighten the castor wheel nuts.• Torque the blade bolts.
Before each use or daily	<ul style="list-style-type: none">• Lubricate the grease fittings.• Check the blades.
Every 50 hours	<ul style="list-style-type: none">• Check the gear box lubricant• Check the blade drive belt adjustment.• Clean under the cutting unit belt covers.• Tighten the castor wheel nuts.• Torque the blade bolts.
Every 400 hours	<ul style="list-style-type: none">• Change the gear box lubricant

⚠ CAUTION

If you leave the key in the ignition switch, someone could accidentally start the engine and seriously injure you or other bystanders.

Remove the key from the ignition switch before you do any maintenance.

Lubricating

Service Interval: Before each use or daily

The machine has grease fittings that must be lubricated regularly with No. 2 General Purpose Lithium Base Grease. If the machine is operated under normal conditions, lubricate all bearings and bushings daily or immediately after every washing. The gear box must be lubricated after every 50 hours of operation.

Lubricate the following areas:

- Castor spindle bushings— 1 each (Figure 17)
- Castor wheel bearings – 1 each (Figure 17)
- Blade spindle bearings – 2 (Figure 18)
- Right and left push arm ball joints – 1 each (Figure 19)

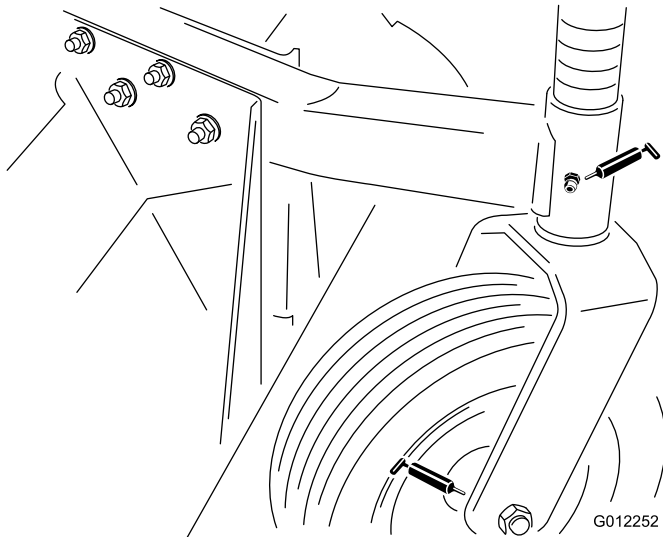

Figure 17

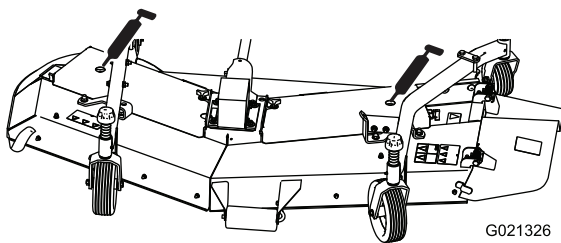

Figure 18

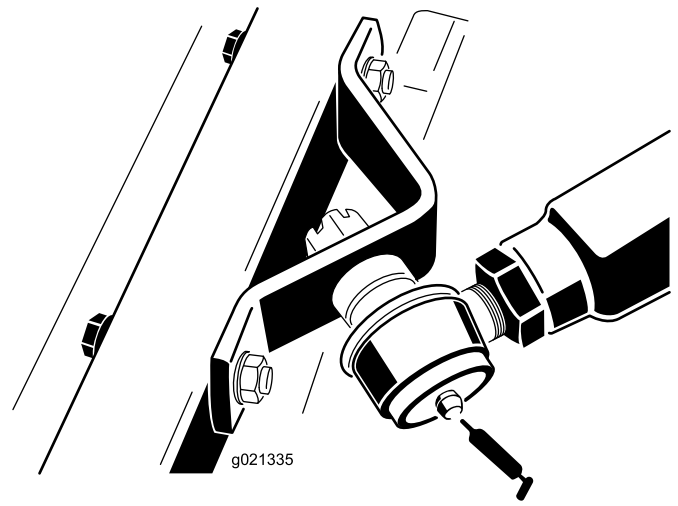

Figure 19

Position the machine and cutting unit on a level surface and lower the cutting unit. Remove the dipstick/fill plug from the top of the gear box (Figure 20) and make sure that the lubricant is between the marks on the dipstick. If the lubricant level is low, add SAE 80-90w gear lube until the level is between the marks.

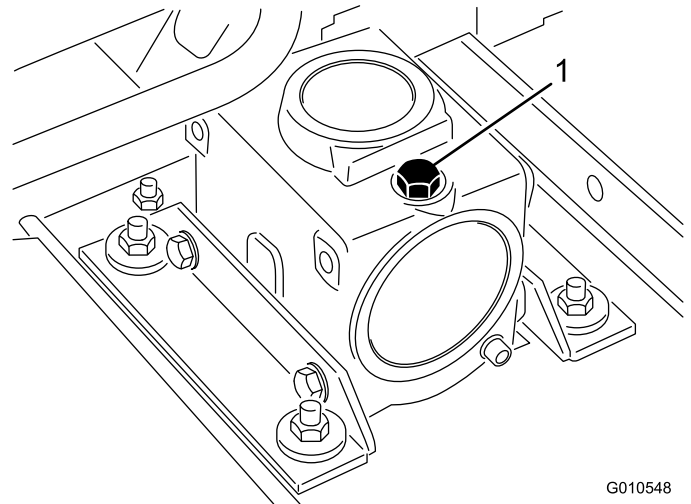

Figure 20

1. Dipstick/fill plug

Separating the Cutting Unit from the Traction Unit

1. Position the machine on level surface, lower the cutting unit to the floor, shut the engine off and engage the parking brake.
2. Remove the self-tapping screws securing the shield to the top of the cutting unit and set the shield aside.
3. Drive out the roll pin securing the drive shaft yoke to the input shaft of the gear box (Figure 21). Loosen the capscrews and locknuts and slide the yoke off of the input shaft. If the traction unit will be used without

the cutting unit, drive the roll pin out of the yoke at traction unit PTO shaft and remove the entire drive shaft from the traction unit.

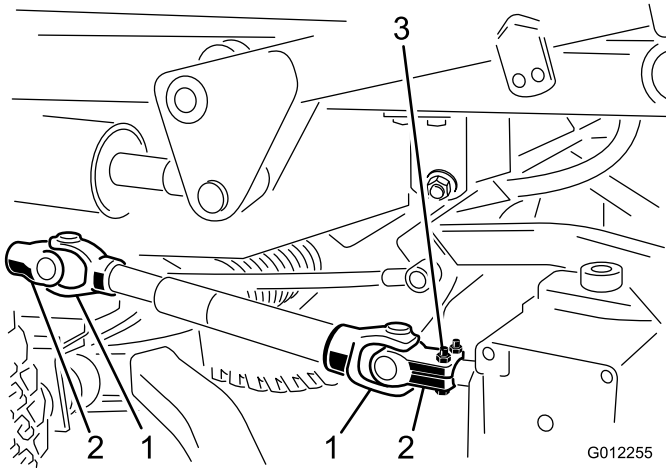

Figure 21

- | | |
|----------------------|----------------------------|
| 1. Drive shaft yokes | 3. Roll pin and cap screws |
| 2. Yokes in phase | |

⚠ DANGER

If the engine is started and the PTO shaft is allowed to rotate, serious injury could result.

Do not start the engine and engage the PTO lever when the PTO shaft is not connected to the gear box on the cutting unit.

4. Disconnect the spring from the lift cylinder cotter pin. Remove the cotter pins and clevis pins securing the lift chains to the lift arm.

⚠ WARNING

The right-hand push arm is spring loaded to about 45 kg (100 lb) and the left-hand push arm is spring loaded to about 68 kg (150 lb). Sudden release of the push arm could cause injury.

Another person is needed to push the arm down during this procedure.

5. Have another person push down on the right push arm while you remove the cap screws, flat washers, and locknuts securing the ball joint mount to the castor arm on the cutting unit (Figure 22). Now the helper can carefully allow the push arm to move upward, which will gradually release the 45 kg (100 lb) of spring load.

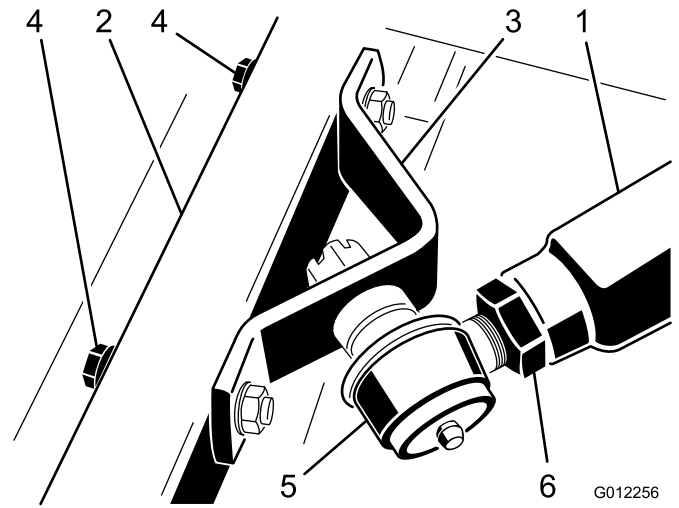

Figure 22

- | | |
|------------------------|---------------------------|
| 1. Right-hand push arm | 4. Cap screws and washers |
| 2. Castor arm | 5. Ball joint |
| 3. Ball joint mount | 6. Jam nut |

6. Have another person push down on the left push arm while you remove the cap screws, flat washers, and locknuts securing the ball joint mount to the castor arm on the cutting unit (Figure 23). Now the helper can carefully allow the push arm to move upward, which will gradually release the 68 kg (150 lb) of spring load

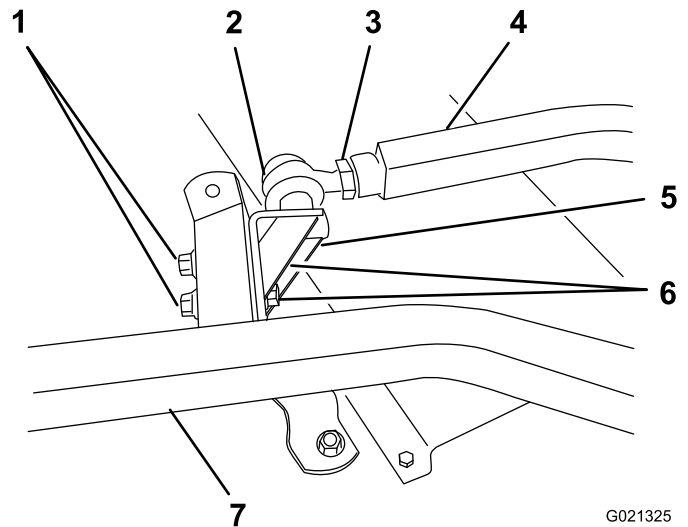

Figure 23

- | | |
|-----------------------|---------------------------|
| 1. Flange nuts | 5. Ball joint mount |
| 2. Ball joint | 6. Cap screws and washers |
| 3. Jam nut | 7. Castor arm |
| 4. Left-hand push arm | |

7. Roll the cutting unit away from the traction unit.

Mounting the Cutting Unit to the Traction Unit

1. Position the machine on a level surface and shut the engine off.
2. Move the cutting unit into position in front of the traction unit.

⚠ WARNING

The right-hand push arm is spring loaded to about 45 kg (100 lb.) and the left-hand push arm is spring loaded to about 68 kg (150 lb.). Sudden release of the push arm could cause injury.

Another person is needed to push the arm down during this procedure.

3. Have another person carefully push down on the right push arm until the holes in the ball joint mount line up with the holes in the castor arm (Figure 22).
4. Secure the ball joint mount to the castor arm with the capscrews, flat washers, and flange nuts. Position the flat washers to the outside of the castor arm.
5. Have another person carefully push down on the left push arm until the holes in the ball joint mount line up with the holes in the castor arm (Figure 23). Immediately slide a 4 x 4 inch block of wood between the top of the push arm and the underside of the chassis.

⚠ WARNING

Sudden release of the push arm could cause injury.

Make sure that the wooden block does not slip out.

6. Secure the ball joint mount and chain bracket to the castor arm with the capscrews, flat washers, and flange nuts. Position the flat washers to the outside of the castor arm. Mount the chain bracket in the forward set of holes.
7. Carefully remove the wood block holding the push arm down.
8. Line up the holes in the yoke and input shaft of the gear box. Slide the yoke onto the shaft and secure them together with a roll pin, 2 capscrews (5/16 x 1-3/4 inches), and 2 locknuts (5/16 inches).

Replacing the Blade Drive Belts

1. Lower the cutting unit to the shop floor, shut off the engine and engage the parking brake.

2. Remove the covers from the top of the cutting unit and set the covers aside.
3. Loosen idler pulleys to the release tension of the belts (Figure 24).
4. Remove the carriage bolts, lock washers and nuts holding the gear box in place. Lift the gear box off the mounting plate and lay it on top of the cutting unit (Figure 24).

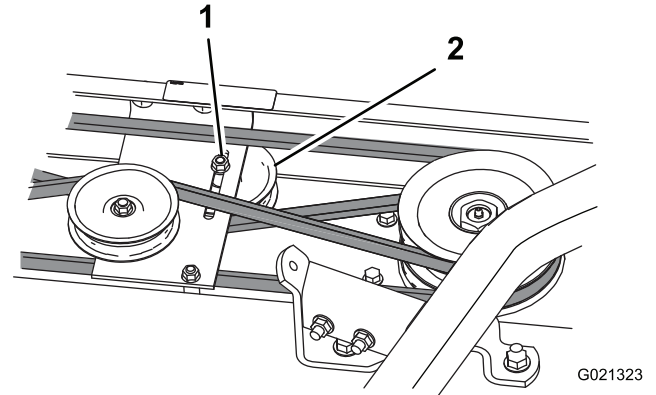

Figure 24

1. Lower belt idler
2. Flange nut

5. Remove the belts from the spindle pulleys.
6. Mount a belt on the lower pulley groove of the left spindle, slide the belt under the belt idler mount plate, and install it around the center spindle pulley.
7. Tension the belt by levering the idler pulley against the belt and tighten the idler pulley flange nut (Figure 24).
8. Place the right spindle belt under the gear box mount plate and the opposite end on top of the right spindle pulley. Place the left spindle belt under the gear box mount plate and the opposite end on top of the left spindle pulley. Mount the gear box and loop the belts around the gear box pulley.
9. Feed the right and left spindle belts over the pulleys by rotating the cutter blades. Tighten the gear box mounting fasteners.
10. Tension the idler pulleys against both belts.
11. Install the covers to the top of the cutting unit.

Servicing the Bushings in the Castor Arms

The castor arms have bushings pressed into the top and bottom of the tube and after many hours of operation, the bushings will wear. To check the bushings, move the castor fork back and forth and from side to side. If the castor spindle is loose inside the bushings, the bushings are worn and must be replaced.

1. Raise the cutting unit so that the wheels are off of the floor. Block the cutting unit so that it cannot accidentally fall.

- Remove the tensioning cap and spacers from the top of the castor spindle.
- Pull the castor spindle out of the mounting tube. Allow the thrust washer and spacer(s) to remain on the bottom of the spindle.
- Insert a pin punch into the top or bottom of the mounting tube and drive the bushing out of the tube (Figure 25). Also drive the other bushing out of the tube. Clean the inside of the tubes to remove dirt.

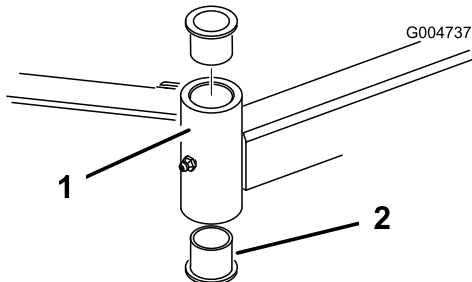

Figure 25

- Castor arm tube
- Bushings

- Apply grease to the inside and outside of the new bushings. Using a hammer and flat plate, drive the bushings into the mounting tube.
- Inspect the castor spindle for wear and replace it if damaged.
- Push the castor spindle through the bushings and mounting tube. Slide the thrust washer and spacer(s) onto the spindle. Install the tensioning cap on the castor spindle to retain all parts in place.

Servicing the Castor Wheels and Bearings

The rear castor wheels rotate on high-quality roller bearings which are supported by spanner bushings. Even after many hours of use, provided that the bearing was kept well-lubricated, bearing wear will be minimal. However, failure to keep the bearings lubricated will cause rapid wear. A wobbly castor wheel usually indicates a worn bearing.

- Remove the capscrew and locknut holding the castor wheel and (2) washers between the castor fork (Figure 26).
- Pull the spanner bushing out of the wheel hub (Figure 26).

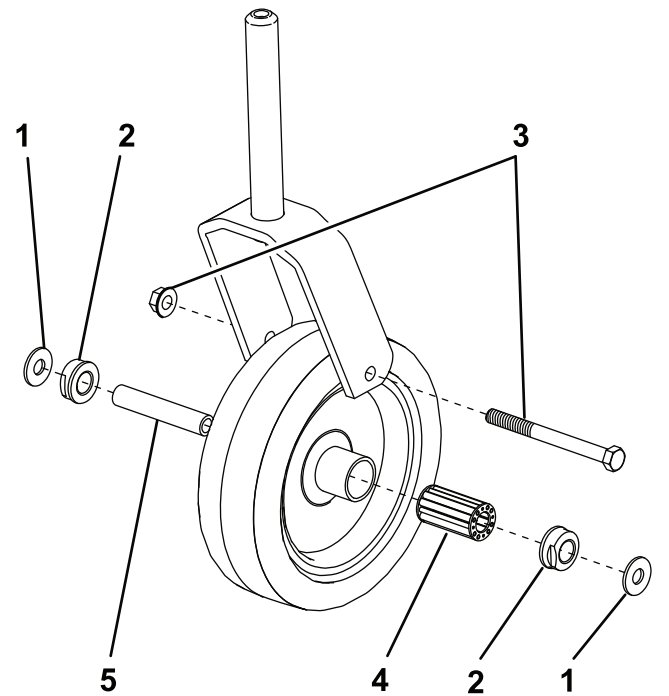

Figure 26

- Washer (2)
- Bushing (2)
- Capscrew and locknut
- Roller bearing
- Spanner bushing

G021327

- Remove the bushing from the wheel hub and allow the bearing to fall out (Figure 26). Remove the bushing from the opposite side of the wheel hub.
- Check the bearing, spanner, and inside of the wheel hub for wear. Replace damaged parts.
- To assemble the castor wheel, push the bushing into the wheel hub. Slide the bearing into the wheel hub. Push the other bushing into the open end of the wheel hub to captivate the bearing inside the wheel hub.
- Carefully slide the spanner through the bushings and wheel hub.
- Install the castor wheel assembly and (2) washers between the castor fork, and secure all parts in place with the capscrew and locknut.
- Lubricate the castor wheel bearing through the grease fitting, using No. 2 general purpose lithium grease.

Removing and Installing the Blade(s)

The blade must be replaced if a solid object is hit, the blade is out-of-balance, worn, or bent. Always use genuine Toro replacement blades to ensure safety and optimum performance. Never use blades made by other manufacturers because they could be dangerous.

- Raise the cutting unit to the highest position, engage the parking brake, stop the engine, and remove the

ignition key. Block the cutting unit to prevent it from accidentally falling.

- Grasp the end of the blade using a rag or thickly padded glove. Remove the special screw, belleville washer and blade from spindle assembly (Figure 27).

Note: The special screw has left hand thread.

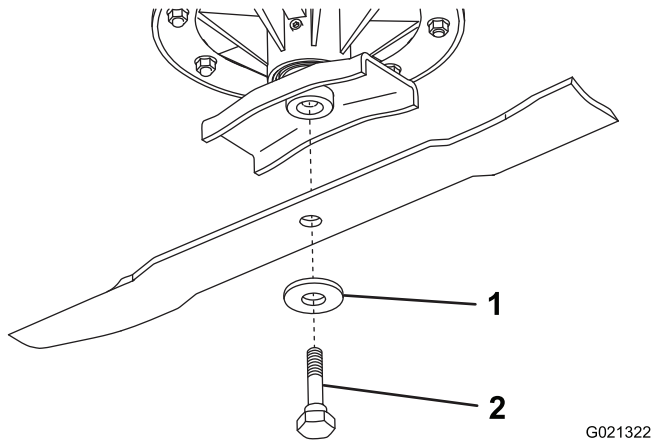

Figure 27

- Belleville washer
- Blade bolt

- Install the blade, sail facing up, with the belleville washer and special screw. Tighten the screw to 102-136 N-m (75-100 ft-lb).

⚠ WARNING

Do not try to straighten a blade that is bent, and never weld a broken or cracked blade. Always use a new blade to ensure continued safety certification of the product.

Inspecting and Sharpening the Blade(s)

Service Interval: Before each use or daily

Every 50 hours

⚠ DANGER

A worn or damaged blade can break, and a piece of the blade could be thrown into the operator's or bystander's area, resulting in serious personal injury or death.

- Inspect the blade periodically for wear or damage.
- Do not try to straighten a blade that is bent.
- Never weld a broken or cracked blade.
- Replace a worn or damaged blade with a new Toro blade to ensure continued safety certification of the product.

- Raise the cutting unit to the highest position, shut the engine off, and engage the parking brake. Block the cutting unit to prevent it from accidentally falling.
- Examine the cutting ends of the blade carefully, especially where the flat and curved parts of the blade meet (Figure 28). Since sand and abrasive material can wear away the metal that connects the flat and curved parts of the blade, check the blade before using the machine. If wear is noticed (Figure 28), replace the blade; refer to Removing the Cutting Blade.

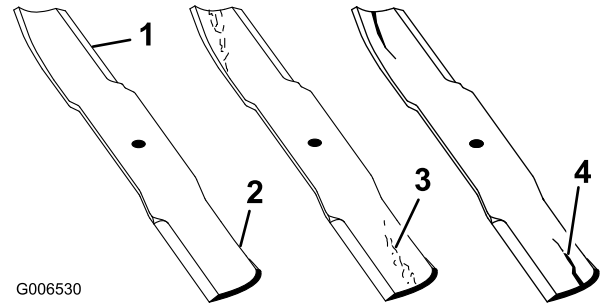

Figure 28

- Cutting edge
- Curved area/sail
- Wear/slot forming
- Crack

⚠ WARNING

If the blade is allowed to wear, a slot will form between the sail and flat part of the blade (Figure 28). Eventually, a piece of the blade may break off and be thrown from under the housing, possibly resulting in serious injury to yourself or bystanders.

- Inspect the blade periodically for wear or damage.
- Replace a worn or damaged blade with a new Toro blade to ensure continued safety certification of the product.

- Examine the cutting edges of all blades. Sharpen the cutting edges if they are dull or nicked. Sharpen only the top side of the cutting edge and maintain the original cutting angle to ensure sharpness (Figure 29). The blade will remain balanced if the same amount of metal is removed from both cutting edges.

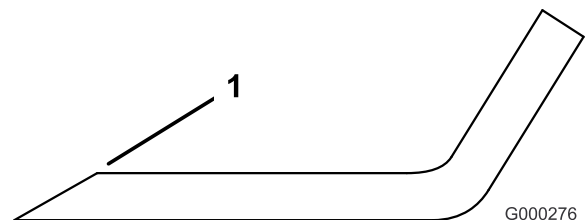

Figure 29

- Sharpen at original angle

4. To check the blade for being straight and parallel, lay the blade on a level surface and check the ends. The ends of the blade must be slightly lower than the center, and the cutting edge must be lower than the heel of the blade. This blade will produce a good quality of cut and require minimal power from the engine. By contrast a blade that is higher at the ends than the center, or if the cutting edge is higher than the heel, the blade is bent or warped and must be replaced.
5. To install the blade, assemble the parts in reverse order, and make sure that the blade sail is facing up. Tighten the special screw to 102 to 136 N-m (75–100 ft.-lb.).
8. Tension idler pulleys against all three belts.
9. Install the covers to the top of the cutting unit.
10. Set the rear castor wheels in the lower holes in the castor forks if the height-of-cut is above 25 mm (1 inch) and adjust the height-of-cut.
11. Adjust the height of cut.

Checking and Correcting Mismatched Blades

If there is mismatch between the blades, the grass will appear streaked when it is cut. This problem can be corrected by making sure that the blades are straight and all of the blades are cutting on the same plane.

1. Using a 1 meter (3 foot) long carpenters level, find a level surface on the shop floor.
2. Set the rear castor wheels in the upper hole of caster forks and adjust the height of cut so all six height of cut spacers are below the caster arm.
3. Lower the cutting unit onto the flat surface. Remove the covers from the top of the cutting unit.
4. Loosen the idler pulleys to release the tension against all three belts.
5. Rotate the blades until the ends face forward and backward. Measure from the floor to the front tip of the cutting edge. Remember this dimension. Then rotate the same blade so that the opposite end is forward, and measure again. The difference between the dimensions must not exceed 3 mm (1/8 inch). If the dimension exceeds 3 mm (1/8 inch), replace the blade because it is bent. Make sure to measure all of the blades.
6. Compare the measurements of the outer blades with the center blade. The center blade must not be more than 10 mm (3/8 inch) lower than the outer blades. If the center blade is more than 10 mm (3/8 inch) lower than the outer blades, proceed to step 7 and add shims between the spindle housing and the bottom of the cutting unit.
7. Remove capscrews, flat washers, lock washers and nuts from outer spindle, in the area where shims must be added. To raise or lower the blade, add a shim, Part No. 3256-24, between spindle housing and bottom of cutting unit. Continue to check alignment of blade and add shims until tips of blades are within the required dimension.

Important: Do not use more than three shims at any one hole location. Use decreasing numbers of

Troubleshooting

Problem	Possible Cause	Corrective Action
The cutting unit will not cut or cuts poorly.	<ol style="list-style-type: none">1. The blades are dull.2. One or more blades are bent or damaged.3. The blade screws are loose.4. The cutting unit belts are loose or broken.5. The gear box pulley is loose.6. A gear box shaft is broken.7. The PTO belt is broken.8. The PTO pulley is loose or broken.9. The PTO shaft is broken.10. The pulley on the engine output shaft is loose or broken.	<ol style="list-style-type: none">1. Sharpen the blades.2. Replace the blades.3. Torque the screws to 102-136 N-m (75-100 ft-lb).4. Tighten or replace the belts as necessary.5. Tighten or replace the pulley.6. Replace any broken shafts.7. Replace the PTO belt.8. Tighten or replace the pulley.9. Replace the PTO shaft.10. Tighten or replace the pulley.

Notes:

Notes:

Declaration of Incorporation

Model No.	Serial No.	Product Description	Invoice Description	General Description	Directive
30722	315000001 and Up	72in Side Discharge Mower, Groundsmaster 300 Series Traction Unit	GM 72" CU SD	Lawn Mower	2006/42/EC, 2000/14/EC

Relevant technical documentation has been compiled as required per Part B of Annex VII of 2006/42/EC.

We will undertake to transmit, in response to requests by national authorities, relevant information on this partly completed machinery. The method of transmission shall be electronic transmittal.

This machinery shall not be put into service until incorporated into approved Toro models as indicated on the associated Declaration of Conformity and in accordance with all instructions, whereby it can be declared in conformity with all relevant Directives.

Certified:



David Klis
Sr. Engineering Manager
8111 Lyndale Ave. South
Bloomington, MN 55420, USA
September 29, 2014

EU Technical Contact:

Peter Tetteroo
Toro Europe NV
B-2260 Oevel-Westerloo
Belgium

Tel. 0032 14 562960
Fax 0032 14 581911



Toro General Commercial Product Warranty

A Two-Year Limited Warranty

Conditions and Products Covered

The Toro Company and its affiliate, Toro Warranty Company, pursuant to an agreement between them, jointly warrant your Toro Commercial product ("Product") to be free from defects in materials or workmanship for two years or 1500 operational hours*, whichever occurs first. This warranty is applicable to all products with the exception of Aerators (refer to separate warranty statements for these products). Where a warrantable condition exists, we will repair the Product at no cost to you including diagnostics, labor, parts, and transportation. This warranty begins on the date the Product is delivered to the original retail purchaser.

* Product equipped with an hour meter.

Instructions for Obtaining Warranty Service

You are responsible for notifying the Commercial Products Distributor or Authorized Commercial Products Dealer from whom you purchased the Product as soon as you believe a warrantable condition exists. If you need help locating a Commercial Products Distributor or Authorized Dealer, or if you have questions regarding your warranty rights or responsibilities, you may contact us at:

Toro Commercial Products Service Department
Toro Warranty Company
8111 Lyndale Avenue South
Bloomington, MN 55420-1196
952-888-8801 or 800-952-2740
E-mail: commercial.warranty@toro.com

Owner Responsibilities

As the Product owner, you are responsible for required maintenance and adjustments stated in your *Operator's Manual*. Failure to perform required maintenance and adjustments can be grounds for disallowing a warranty claim.

Items and Conditions Not Covered

Not all product failures or malfunctions that occur during the warranty period are defects in materials or workmanship. This warranty does not cover the following:

- Product failures which result from the use of non-Toro replacement parts, or from installation and use of add-on, or modified non-Toro branded accessories and products. A separate warranty may be provided by the manufacturer of these items.
- Product failures which result from failure to perform recommended maintenance and/or adjustments. Failure to properly maintain your Toro product per the Recommended Maintenance listed in the *Operator's Manual* can result in claims for warranty being denied.
- Product failures which result from operating the Product in an abusive, negligent, or reckless manner.
- Parts subject to consumption through use unless found to be defective. Examples of parts which are consumed, or used up, during normal Product operation include, but are not limited to, brake pads and linings, clutch linings, blades, reels, rollers and bearings (sealed or greasable), bed knives, spark plugs, castor wheels and bearings, tires, filters, belts, and certain sprayer components such as diaphragms, nozzles, and check valves, etc.
- Failures caused by outside influence. Conditions considered to be outside influence include, but are not limited to, weather, storage practices, contamination, use of unapproved fuels, coolants, lubricants, additives, fertilizers, water, or chemicals, etc.
- Failure or performance issues due to the use of fuels (e.g. gasoline, diesel, or biodiesel) that do not conform to their respective industry standards.

Countries Other than the United States or Canada

Customers who have purchased Toro products exported from the United States or Canada should contact their Toro Distributor (Dealer) to obtain guarantee policies for your country, province, or state. If for any reason you are dissatisfied with your Distributor's service or have difficulty obtaining guarantee information, contact the Toro importer.

- Normal noise, vibration, wear and tear, and deterioration.
- Normal "wear and tear" includes, but is not limited to, damage to seats due to wear or abrasion, worn painted surfaces, scratched decals or windows, etc.

Parts

Parts scheduled for replacement as required maintenance are warranted for the period of time up to the scheduled replacement time for that part. Parts replaced under this warranty are covered for the duration of the original product warranty and become the property of Toro. Toro will make the final decision whether to repair any existing part or assembly or replace it. Toro may use remanufactured parts for warranty repairs.

Deep Cycle and Lithium-Ion Battery Warranty:

Deep cycle and Lithium-Ion batteries have a specified total number of kilowatt-hours they can deliver during their lifetime. Operating, recharging, and maintenance techniques can extend or reduce total battery life. As the batteries in this product are consumed, the amount of useful work between charging intervals will slowly decrease until the battery is completely worn out. Replacement of worn out batteries, due to normal consumption, is the responsibility of the product owner. Battery replacement may be required during the normal product warranty period at owner's expense. Note: (Lithium-Ion battery only): A Lithium-Ion battery has a part only prorated warranty beginning year 3 through year 5 based on the time in service and kilowatt hours used. Refer to the *Operator's Manual* for additional information.

Maintenance is at Owner's Expense

Engine tune-up, lubrication, cleaning and polishing, replacement of filters, coolant, and completing recommended maintenance are some of the normal services Toro products require that are at the owner's expense.

General Conditions

Repair by an Authorized Toro Distributor or Dealer is your sole remedy under this warranty.

Neither The Toro Company nor Toro Warranty Company is liable for indirect, incidental or consequential damages in connection with the use of the Toro Products covered by this warranty, including any cost or expense of providing substitute equipment or service during reasonable periods of malfunction or non-use pending completion of repairs under this warranty. Except for the Emissions warranty referenced below, if applicable, there is no other express warranty. All implied warranties of merchantability and fitness for use are limited to the duration of this express warranty.

Some states do not allow exclusions of incidental or consequential damages, or limitations on how long an implied warranty lasts, so the above exclusions and limitations may not apply to you. This warranty gives you specific legal rights, and you may also have other rights which vary from state to state.

Note regarding engine warranty:

The Emissions Control System on your Product may be covered by a separate warranty meeting requirements established by the U.S. Environmental Protection Agency (EPA) and/or the California Air Resources Board (CARB). The hour limitations set forth above do not apply to the Emissions Control System Warranty. Refer to the Engine Emission Control Warranty Statement supplied with your product or contained in the engine manufacturer's documentation for details