



Count on it.

Parts Catalog

VR-3500 Rammer Compactor

Model No. 68036—Serial No. 314000001 and Up



Ordering Replacement Parts

To order replacement parts, please supply the part number, the quantity, and the description of each part desired.

Understanding Reference Numbers

Each identified part in an illustration has a reference number. The reference number for a part also appears in the parts list, along with other information about the part.

This catalog uses two special reference number formats, one to indicate parts in a service assembly and another to indicate the quantity of a given part in an illustration.

Service Assembly Reference Numbers

Parts in service assemblies have reference numbers in the form a:b. The a represents the reference number of the entire service assembly and the b represents a sequential number unique to each part within the service assembly.

For example, a wheel assembly might be identified by reference number 6, the tire by 6:1, the valve by 6:2, and the wheel by 6:3. When you order the assembly identified by reference number 6, you receive all parts identified by reference numbers 6:1, 6:2, and 6:3. However, you may also order any part individually. Reference numbers of this type appear in illustration and in parts lists.

Reference Numbers Indicating Quantity

In an illustration, if a reference number indicates more than one part, the reference number has the form nX y. The n represents the quantity of the part, the X is the multiplication symbol, and the y represents the reference number.

For example, in an illustration, the reference number 2X 37 means that two of the parts identified by reference number 37 are indicated.

List of Abbreviations

AR: as required

ASM: assembly

BBC: blade brake control

BHTF: button head thread forming

CARR: carriage

CCW: counter clockwise

CW: clockwise

DEG: degrees

DPA: Dual Point Adjustment

ECM: electronic control module

EXT: external

FH: flat head

GA: gauge

HD: heavy-duty

HF: hex flange

HH: hex head

HHF: hex head flange

HHFTF: hex head flange thread forming

HJ: hex jam

HLH: hex lag head

HOC: height-of-cut

HSBH: hex socket button head

HSFH: hex socket flat head

HSH: hex socket head

HWH: hex washer head

HWHTF: hex washer head thread forming

HYD: hydraulic

LH: left hand

LP: Liquefied Petroleum Gas

LPG: Liquefied Petroleum Gas

NI: nylon insert

NPTF: national pipe thread fine

PFH: phillips flat head

PPH: phillips pan head

PPHTF: phillips pan head thread forming

PRH: phillips round head

PTH: phillips truss head

PTO: power-take-off

RH: right hand

ROPS: roll-over protection system

RRB: rear roller brush

SFH: slotted fillister head

SHH: slotted hex head

SHWH: slotted hex washer head

SPH: slotted pan head

SQH: square head

SRH: slotted round head

STD: standard

TAP: self tapping

TTH: torx truss head

Contents

Frame, Handle and Fuel Tank Assembly 4
Engine and Air Filter Assembly 6
Lower Unit Assembly 8
Rammer Assembly 10

Frame, Handle and Fuel Tank Assembly

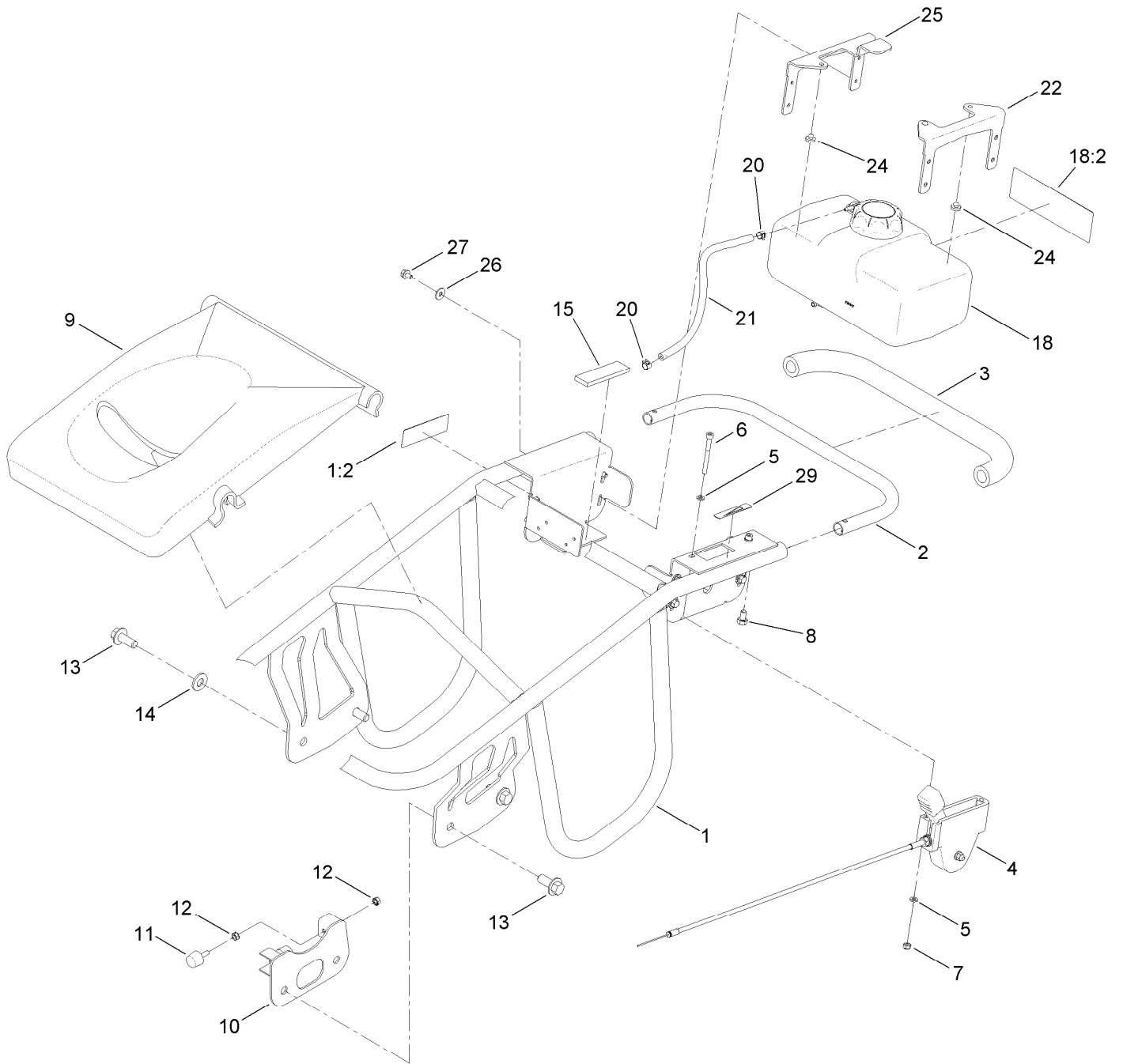

Frame, Handle and Fuel Tank Assembly (continued)

<i>Ref.</i>	<i>Part Number</i>	<i>Qty.</i>	<i>Description</i>	<i>Ref.</i>	<i>Part Number</i>	<i>Qty.</i>	<i>Description</i>
1	127-2877	1	Handle ASM	13	33106-020	4	Screw-HHF
1:2	117-2718	1	Decal-Arrester, Spark	14	29-8910	2	Washer
2	ST39460-03	1	Handle-Grip, Tube	15	125-6239	2	Pad-Tank, Fuel
3	ST39470	1	Grip-Hand	18	127-7574	1	1 Gallon Fuel Tank ASM
4	125-8673	1	Lever-Throttle	18:2	125-8191	1	Decal-Warning
5	33093-00	4	Washer-Flat	20	2412-80	2	Clamp-Hose
6	ST80940	2	Screw-HSH	21	115-4735	1	Hose-Fuel
7	115-7373	2	Nut-Lock	22	ST66668-03	1	Bracket-Top, Fuel Tank
8	ST80586	2	Screw-HWH	24	ST47292	4	Bumper-Rubber
9	125-4804	1	Cover-Engine	25	127-7556-03	1	Guard-Fuel Tank, Top
10	ST39424-03	1	Stopper	26	ST81181	8	Washer-Flat
11	ST39427	2	Mount-Shock	27	81-1280	8	Screw-HHF
12	98-5845	4	Nut-Hex	29	125-8182	1	Decal-Throttle

Engine and Air Filter Assembly

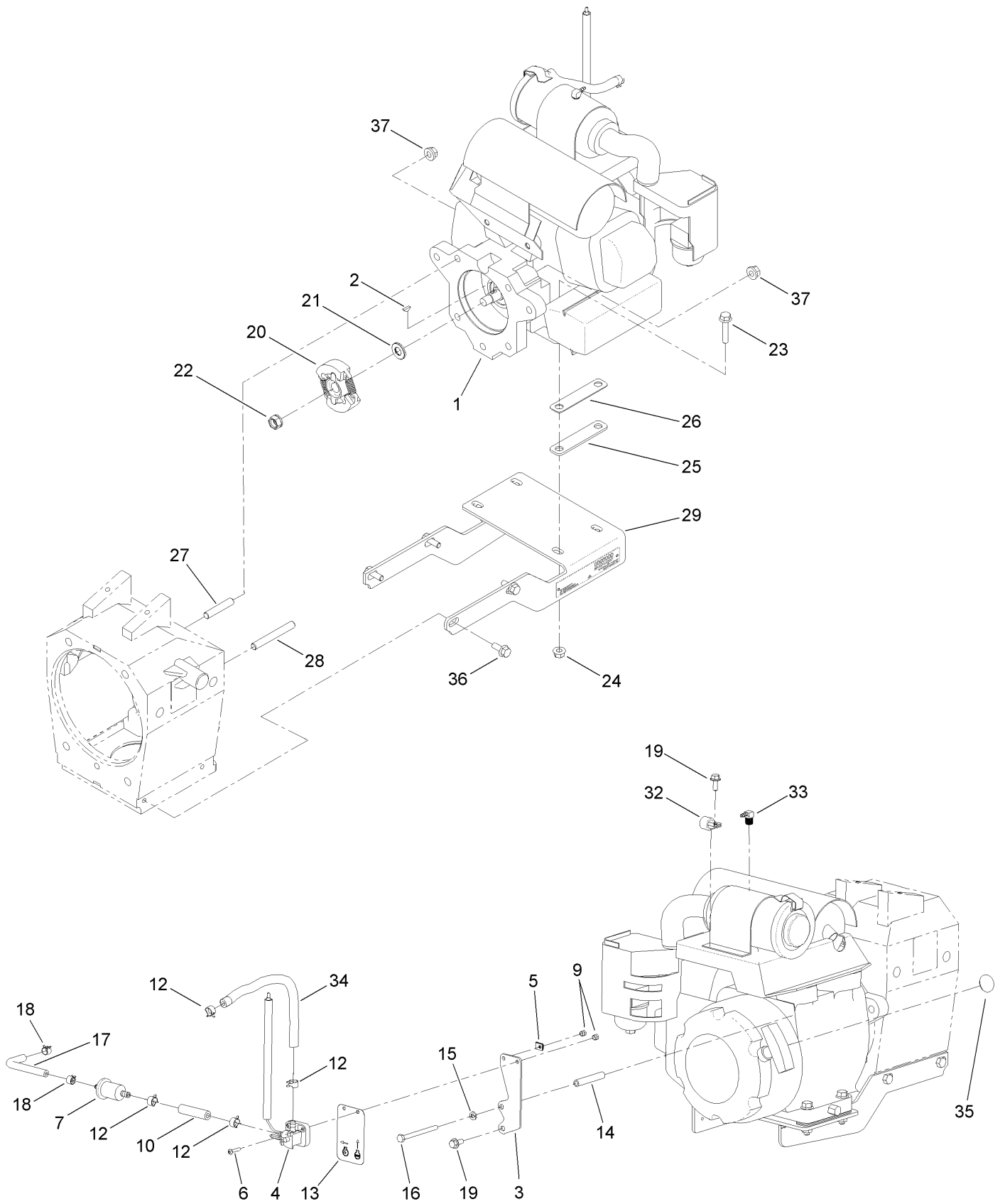

Engine and Air Filter Assembly (continued)

<i>Ref.</i>	<i>Part Number</i>	<i>Qty.</i>	<i>Description</i>	<i>Ref.</i>	<i>Part Number</i>	<i>Qty.</i>	<i>Description</i>
1	125-4817	1	Engine-Honda, Gx120 ●	20	ST30291	1	Clutch-Friction
2	ST32525	1	Key-Woodruff	21	ST58857	1	Spacer-Clutch
3	ST50362	1	Plate-Switch, Stop	22	ST32524	1	Nut-Hex Flange
4	ST58582	1	Fuel Shut Off Valve ASM	23	33104-040	4	Screw-HHF
5	ST39502	1	Clamp	24	33004-00	4	Nut-HF
6	119-7444	2	Screw-HSBH	25	ST50414-03	2	Shim-Engine (11GA)
7	ST31231	1	Filter-Fuel	26	ST50415-03	2	Shim-Engine (16GA)
9	46-0430	2	Nut-Lock	27	ST81207	3	Stud
10	99-9415	1	Hose-Fuel	28	ST81208	1	Stud
12	2412-98	4	Clamp-Hose	29	127-2800-03	1	Support-Engine
13	125-4966	1	Hang Tag-Run, Stop	32	2412-73	1	Clamp-R
14	ST50361	1	Tube-Switch, Stop	33	127-7575	1	Elbow-90
15	43-5930	1	Washer-Lock, Spring	34	109-0298	1	Fuel Line
16	ST81354	1	Screw-HH	35	ST32523	1	Plug-Rubber
17	51-3214	1	Hose-Fuel	36	33104-020	4	Screw-HHF
18	2412-80	2	Clamp-Hose	37	ST81209	4	Nut
19	33103-016	2	Screw-HHF				

● Obtain parts from www.honda-engines.com

Lower Unit Assembly

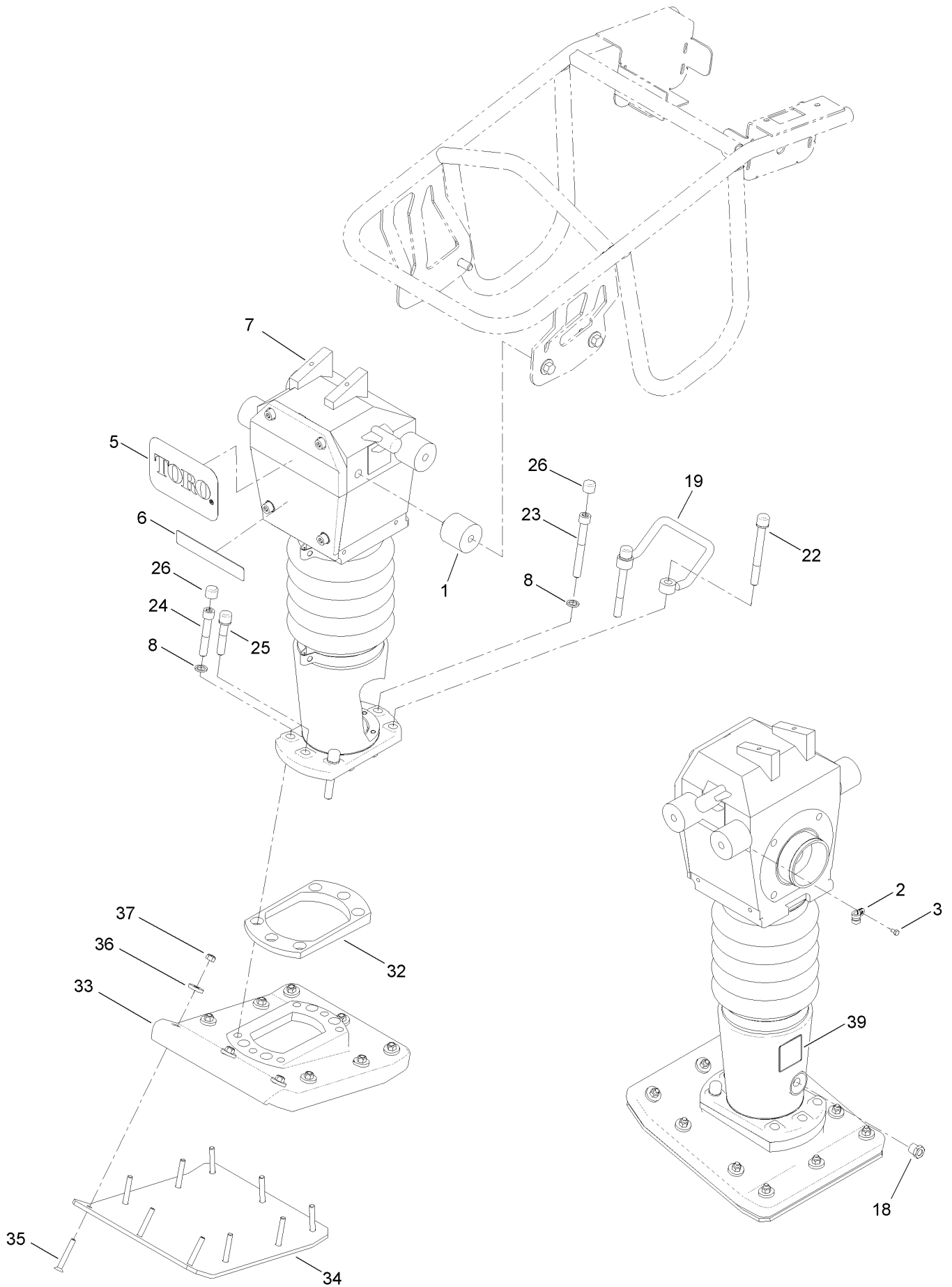

Lower Unit Assembly (continued)

<i>Ref.</i>	<i>Part Number</i>	<i>Qty.</i>	<i>Description</i>	<i>Ref.</i>	<i>Part Number</i>	<i>Qty.</i>	<i>Description</i>
1	ST39425	4	Mount-Shock	24	ST80945	2	Screw-HSH
2	ST39509	1	Clamp	25	ST80827	1	Screw-HSH
3	ST81043	1	Screw-HH	26	ST80765	6	Cap-Plastic
5	127-7590	1	Decal	32	ST50371	1	Plate-Spacer, Shoe
6	127-7593	1	Decal	33	ST47302	1	Shoe-Plastic, Medium/Heavy
7		1	Rammer ASM ●	34	ST65024-03	1	Plate-Shoe
8	ST81196	6	Washer-Lock	35	ST80948	10	Screw-HSFH
18	ST34096	1	Plug-Sight, Oil	36	ST26325	10	Washer-Flat
19	ST39480-03	1	Grip-Lift	37	33024-00	10	Nut-Lock, NI
22	ST81193	2	Screw-HSH	39	127-7595	1	Decal-Oil Level
23	ST80943	1	Screw-HSH				

● Not serviced separately

Rammer Assembly

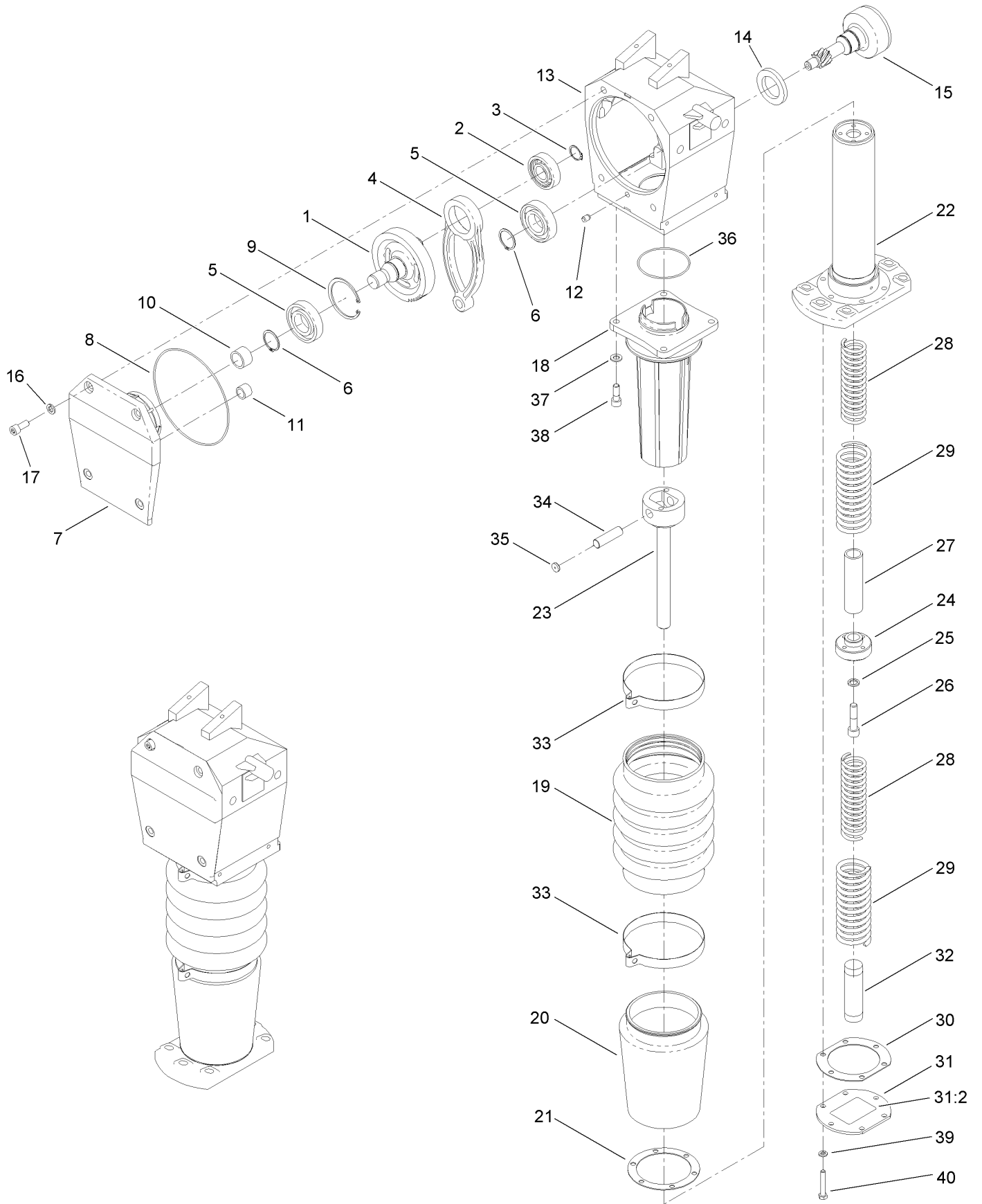

Rammer Assembly (continued)

<i>Ref.</i>	<i>Part Number</i>	<i>Qty.</i>	<i>Description</i>	<i>Ref.</i>	<i>Part Number</i>	<i>Qty.</i>	<i>Description</i>
1	ST50310	1	Gear-Helical	22	125-8675	1	Housing-Spring
2	ST39429	1	Bearing-Ball	23	ST50305	1	Rod-Piston
3	ST39432	1	Ring-External	24	ST50465	1	Puck-Piston
4	ST50302	1	Rod-Connecting	25	ST81196	1	Washer-Lock
5	ST39428	2	Bearing-Ball	26	ST80822	1	Screw-HSH
6	32120-84	2	Ring-Snap, External	27	ST50410	1	Snubber-Spring, Upper
7	ST50294	1	Cover-Front	28	ST50282	2	Spring-Compression, Inner
8	ST39437	1	O-Ring	29	ST50283	2	Spring-Compression, Outer
9	ST50539	1	Ring-Internal	30	ST39390	1	Gasket-Cover, Spring
10	ST39430	1	Bearing-Needle	31	127-2831	1	Bottom Spring Cover ASM
11	ST39431	1	Bearing-Needle	31:2	125-8181	1	Decal-Warning, Spring
12	ST80543	1	Pin	32	ST50411	1	Snubber-Spring, Lower
13	ST50304	1	Gearcase	33	ST39439	2	Clamp-Boot, Stomper
14	ST39435	1	Seal-Shaft	34	ST39436	1	Pin
15	ST50192	1	Pinion	35	ST39401	2	Button-Pin, Captivator
16	42-9600	4	Washer-Lock, Spring	36	ST39438	1	O-Ring
17	ST80803	4	Screw-HSH	37	33095-00	4	Washer-Flat
18	ST50281	1	Guide-Tube	38	ST80872	4	Screw-HSH
19	ST50408	1	Boot-Stomper	39	ST80812	6	Washer-Lock
20	ST50409	1	Cover-Housing, Spring	40	33114-050	6	Screw-HH
21	ST39399	1	Gasket-Housing, Spring Cover				



Count on it.