



Count on it.

Operator's Manual

TRX-16, TRX-20, and TRX-26 Trencher

Model No. 22972—Serial No. 314000001 and Up

Model No. 22972G—Serial No. 314000001 and Up

Model No. 22973—Serial No. 314000001 and Up

Model No. 22973G—Serial No. 314000001 and Up

Model No. 22974—Serial No. 314000001 and Up

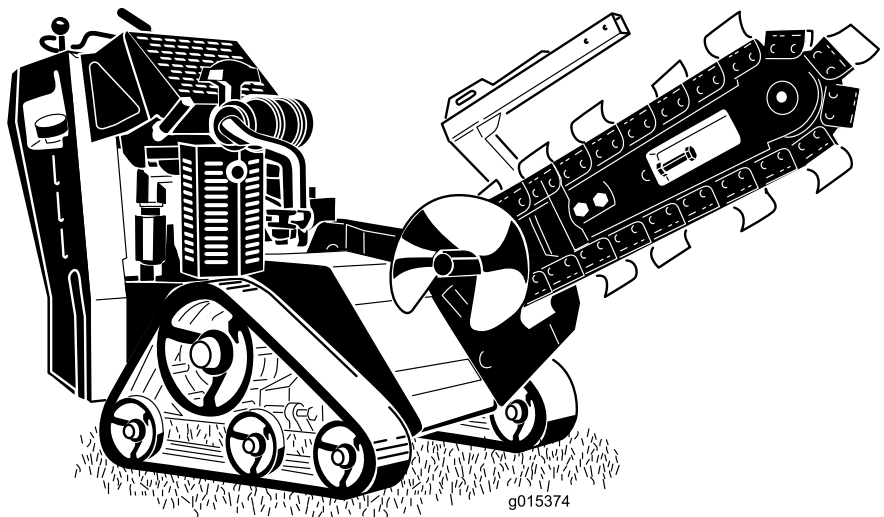

This machine is designed to dig trenches in soil to bury cabling and piping for various applications. It is not intended to cut rock, wood, or any other material other than soil.

⚠ WARNING

CALIFORNIA Proposition 65 Warning

This product contains a chemical or chemicals known to the State of California to cause cancer, birth defects, or reproductive harm.

The engine exhaust from this product contains chemicals known to the State of California to cause cancer, birth defects, or other reproductive harm.

⚠ DANGER

There may be buried power, gas, and/or telephone lines in the work area. Shock or explosion may occur if you dig into them.

Have the property or work area marked for buried lines and do not dig in marked areas. Contact your local marking service or utility company to have the property marked (for example, in the United States, call 811 for the nationwide marking service).

This spark ignition system complies with Canadian ICES-002.

Important: This engine is not equipped with a spark arrester muffler. It is a violation of California Public Resource Code Section 4442 to use or operate the engine on any forest-covered, brush-covered, or grass-covered land. Other states or federal areas may have similar laws.

The enclosed *Engine Owner's Manual* is supplied for information regarding the US Environmental Protection Agency (EPA) and the California Emission Control Regulation of emission systems, maintenance, and warranty. Replacements may be ordered through the engine manufacturer.

This product complies with all relevant European directives; for details, please see the separate product specific Declaration of Conformity (DOC) sheet.

Introduction

Read this information carefully to learn how to operate and maintain your product properly and to avoid injury and product damage. You are responsible for operating the product properly and safely.

You may contact Toro directly at www.Toro.com for product and accessory information, help finding a dealer, or to register your product.

Whenever you need service, genuine Toro parts, or additional information, contact an Authorized Service Dealer or Toro Customer Service and have the model and serial numbers of your product ready. Figure 1 illustrates the location of the model and serial numbers on the product. Write the numbers in the space provided.

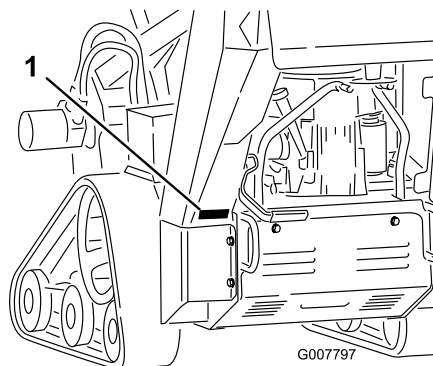

Figure 1

1. Model and serial number plate

Model No. _____

Serial No. _____

This manual identifies potential hazards and has safety messages identified by the safety alert symbol (Figure 2), which signals a hazard that may cause serious injury or death if you do not follow the recommended precautions.



Figure 2

1. Safety alert symbol

This manual uses 2 words to highlight information.

Important calls attention to special mechanical information and **Note** emphasizes general information worthy of special attention.

Contents

Introduction	2
Safety	4
Safe Operating Practices	4
Sound Pressure	6
Sound Power	6
Vibration.....	6
Slope Indicator	7
Safety and Instructional Decals	8
Setup	12
1 Installing the Boom and Chain	12
2 Checking Fluid Levels.....	13
3 Charging the Battery (Electric Start Models Only)	13
Product Overview	13
Controls	13
Specifications	16
Attachments/Accessories.....	16
Operation	16
Recommended Fuel.....	16
Checking the Engine-Oil Level.....	17
Checking the Hydraulic Fluid Level.....	17
Starting and Stopping the Engine.....	19
Stopping the Machine	19
Moving a Non-functioning Machine	19
Digging a Trench.....	20
Securing the Machine for Transport	20
Lifting the Machine	20
Operating Tips	21
Maintenance	22
Recommended Maintenance Schedule(s)	22
Pre-maintenance Procedures	23
Removing the Cover Plate.....	23
Installing the Cover Plate.....	23
Removing the Bottom Shield	23
Installing the Bottom Shield.....	23
Lubrication	24
Greasing the Machine	24
Greasing the Trencher Housing.....	24
Engine Maintenance	25
Servicing the Air Cleaner (Models 22972 and 22973).....	25
Servicing the Air Cleaner (Model 22974)	26
Servicing the Engine Oil.....	27
Servicing the Spark Plug.....	28
Fuel System Maintenance	29
Draining the Fuel Tank	29
Replacing the Fuel Filter.....	30
Electrical System Maintenance	30
Servicing the Battery (Models 22973 and 22974).....	30
Replacing the Fuses (Models 22973 and 22974).....	32
Drive System Maintenance	33
Servicing the Tracks.....	33
Belt Maintenance	35
Replacing the Pump Drive Belt.....	35

Controls System Maintenance	36
Adjusting the Traction Control Alignment	36
Adjusting the Traction Control Neutral Position.....	37
Adjusting the Tracking of the Traction Control, Full Forward Position.....	37
Hydraulic System Maintenance	38
Replacing the Hydraulic Filter	38
Changing the Hydraulic Fluid.....	38
Checking the Hydraulic Lines.....	39
Trencher Maintenance	40
Replacing the Digging Teeth	40
Checking and Adjusting the Digging Chain and Boom.....	40
Replacing the Drive Sprocket	40
Cleaning	42
Removing Debris from the Machine.....	42
Storage	42
Troubleshooting	44
Schematics	46

Safety

Improper use or maintenance by the operator or owner can result in injury. To reduce the potential for injury, comply with these safety instructions and always pay attention to the safety alert symbol **A**, which means: *Caution, Warning, or Danger*—personal safety instruction. Failure to comply with the instruction may result in personal injury or death.

Safe Operating Practices

This product is capable of amputating hands and feet. Always follow all safety instructions to avoid serious injury or death.

A WARNING

Engine exhaust contains carbon monoxide, an odorless, deadly poison that can kill you.

Do not run the engine indoors or in an enclosed area.

Training

- Read the *Operator's Manual* and other training material. If the operator(s) or mechanic(s) can't read English, it is the owner's responsibility to explain this material to them.
- Become familiar with the safe operation of the equipment, operator controls, and safety signs.
- All operators and mechanics should be trained. The owner is responsible for training the users.
- Never let children or untrained people operate or service the equipment. Local regulations may restrict the age of the operator.
- The owner/user can prevent and is responsible for accidents or injuries occurring to himself or herself, other people or property.

Preparation

- Evaluate the terrain to determine what accessories and attachments are needed to properly and safely perform the job. Only use accessories and attachments approved by the manufacturer.
- Wear appropriate clothing including hard hat, safety glasses, long pants, safety shoes, and hearing protection. Long hair, loose clothing or jewelry may get tangled in moving parts.
- Inspect the area where the equipment is to be used and remove all objects such as rocks, toys, and wire which can be thrown by the machine.
- Use extra care when handling gasoline and other fuels. They are flammable and vapors are explosive.
 - Use only an approved container
 - Never remove the gas cap or add fuel with the engine running. Allow the engine to cool before refueling. Do not smoke.

– Never refuel or drain the machine indoors.

- Check that the operator presence controls, safety switches, and shields are attached and functioning properly. Do not operate unless they are functioning properly.

Operation

- Never run an engine in an enclosed area.
- Only operate in good light, keeping away from holes and hidden hazards.
- Be sure all drives are in neutral and the parking brake is engaged before starting the engine. Only start the engine from the operator's position.
- Slow down and use extra care on hillsides. Be sure to travel in the recommended direction on hillsides. Turf conditions can affect the machine's stability.
- Slow down and use caution when making turns and when changing directions on slopes.
- Never operate without the guards securely in place. Be sure all interlocks are attached, adjusted, and functioning properly.
- Do not change the engine governor setting or overspeed the engine.
- Stop on level ground, lower the boom, disengage the trencher hydraulics, engage the parking brake, and shut off the engine before leaving the operator's position for any reason.
- Keep hands and feet away from the moving chain, digging teeth, and spoils auger.
- Look behind and down before backing up to be sure of a clear path.
- Never carry passengers and keep pets and bystanders away.
- Slow down and use caution when making turns and crossing roads and sidewalks.
- Do not operate the machine under the influence of alcohol or drugs.
- Use care when loading or unloading the machine into a trailer or truck.
- Use care when approaching blind corners, shrubs, trees, or other objects that may obscure vision.
- Ensure that the area is clear of other people before operating the machine. Stop the machine if anyone enters the area.
- Never leave a running machine unattended. Always lower the boom, stop the engine, set the parking brake, and remove the key before leaving.
- Never jerk the controls; use a steady motion.
- Watch for traffic when operating near or crossing roadways.
- Do not touch parts which may be hot from operation. Allow them to cool before attempting to maintain, adjust, or service.

- Ensure that you operate the machine in areas where there are no obstacles in close proximity to the operator. Failure to maintain adequate distance from trees, walls, and other barriers may result in injury as the machine backs up during operation if the operator is not attentive to the surroundings. Only operate the unit in areas where there is sufficient clearance for the operator to safely maneuver the product.
- Before digging, have the area marked for underground utilities, and do not dig in marked areas.
- Locate the pinch point areas marked on the machine and keep hands and feet away from these areas.
- Lightning can cause severe injury or death. If lightning is seen or thunder is heard in the area, do not operate the machine; seek shelter.

Slope Operation

Slopes are a major factor related to loss-of-control and tip-over accidents, which can result in severe injury or death. All slopes require extra caution.

- Do not operate the machine on hillsides or slopes exceeding the angles recommended in the following table.

Model	Front Facing Uphill	Rear Facing Uphill	Side Facing Uphill
22972	15°	14°	19°
22973	13°	14°	19°
22974	11°	11°	16°

Note: See also the Slope Indicator (page 7).

- **Operate up and down slopes with the front end of the machine uphill.**
- Remove obstacles such as rocks, tree limbs, etc. from the work area. Watch for holes, ruts, or bumps, as uneven terrain could overturn the machine. Tall grass can hide obstacles.
- Use only Toro-approved accessories. Accessories can change the stability and the operating characteristics of the machine. Warranty may be voided if used with unapproved accessories.
- Keep all movements on slopes slow and gradual. Do not make sudden changes in speed or direction.
- Avoid starting or stopping on a slope. If the machine loses traction, proceed slowly, straight down the slope.
- Avoid turning on slopes. If you must turn, turn slowly and keep the heavy end of the machine uphill.
- Do not operate near drop-offs, ditches, or embankments. The machine could suddenly turn over if a track goes over the edge of a cliff or ditch, or if an edge caves in.
- Do not operate on wet grass. Reduced traction could cause sliding.
- Do not park the machine on a hillside or slope without lowering the boom to the ground, setting the parking brake, and chocking the tracks.

Maintenance and Storage

- Disengage the trencher hydraulics, lower the boom, set the parking brake, stop the engine, and remove the key. Wait for all movement to stop before adjusting, cleaning, or repairing.
- Clean debris from the chain, digging teeth, boom, trencher head, drives, mufflers, and engine to help prevent fires. Clean up oil or fuel spillage.
- Let the engine cool before storing and do not store near flame.
- Do not store fuel near flames or drain indoors.
- Park the machine on level ground. Never allow untrained personnel to service the machine.
- Use jack stands to support components when required.
- Carefully release pressure from components with stored energy.
- Disconnect the battery (electric start models only) or remove the spark plug wires before making any repairs. Disconnect the negative terminal first and the positive last. Reconnect positive first and negative last.
- Keep hands and feet away from moving parts. If possible, do not make adjustments with the engine running.
- Keep all parts in good working condition and all hardware tightened. Replace all worn or damaged decals.
- Keep nuts and bolts tight. Keep equipment in good condition.
- Never tamper with safety devices.
- Keep the machine free of grass, leaves, or other debris build-up. Clean up oil or fuel spillage. Allow the machine to cool before storing.
- Use extra care when handling gasoline and other fuels. They are flammable and vapors are explosive.
 - Use only an approved container.
 - Never remove the gas cap or add fuel when the engine is running. Allow the engine to cool before refueling. Do not smoke.
 - Never refuel the machine indoors.
 - Never store the machine or fuel container inside where there is an open flame, such as near a water heater or furnace.
 - Never fill a container while it is inside a vehicle, trunk, pick-up bed, or any surface other than the ground.
 - Keep container nozzle in contact with the tank during filling.
- Stop and inspect the equipment if you strike an object. Make any necessary repairs before restarting.
- Use only genuine Toro replacement parts to ensure that original standards are maintained.
- Battery safety (electric start models only):

- Charge batteries in an open, well ventilated area, away from spark and flames. Unplug the charger before connecting or disconnecting it from the battery. Wear protective clothing and use insulated tools.
- Battery acid is poisonous and can cause burns. Avoid contact with skin, eyes, and clothing. Protect your face, eyes, and clothing when working with a battery.
- Battery gases can explode. Keep cigarettes, sparks and flames away from the battery.
- Keep your body and hands away from pin hole leaks or nozzles that eject high pressure hydraulic fluid. Use cardboard or paper to find hydraulic leaks; never use your hands. Hydraulic fluid escaping under pressure can penetrate skin and cause injury requiring surgery within a few hours by a qualified surgeon or gangrene may result.

Sound Pressure

Model 22972

This unit has a sound pressure level at the operator's ear of 89 dBA, which includes an Uncertainty Value (K) of 1.0 dBA.

Sound pressure level was determined according to the procedures outlined in EN ISO 11201.

Model 22973

This unit has a sound pressure level at the operator's ear of 90 dBA, which includes an Uncertainty Value (K) of 1.0 dBA.

Sound pressure level was determined according to the procedures outlined in EN ISO 11201.

Model 22974

This unit has a sound pressure level at the operator's ear of 93 dBA, which includes an Uncertainty Value (K) of 1.0 dBA.

Sound pressure level was determined according to the procedures outlined in EN ISO 11201.

Sound Power

Model 22972

This unit has a guaranteed sound power level of 107 dBA, which includes an Uncertainty Value (K) of 3.75 dBA.

Sound power level was determined according to the procedures outlined in EN ISO 3744.

Model 22973

This unit has a guaranteed sound power level of 108 dBA, which includes an Uncertainty Value (K) of 3.75 dBA.

Sound power level was determined according to the procedures outlined in EN ISO 3744.

Model 22974

This unit has a guaranteed sound power level of 107 dBA, which includes an Uncertainty Value (K) of 3.75 dBA.

Sound power level was determined according to the procedures outlined in EN ISO 3744.

Vibration

Model 22972

Measured vibration level for right hand = 2.1 m/s²

Measured vibration level for left hand = 2.0 m/s²

Uncertainty Value (K) = 1.1 m/s²

Measured values were determined according to the procedures outlined in EN ISO 20643.

Model 22973

Measured vibration level for right hand = 2.3 m/s²

Measured vibration level for left hand = 2.1 m/s²

Uncertainty Value (K) = 1.1 m/s²

Measured values were determined according to the procedures outlined in EN ISO 20643.

Model 22974

Measured vibration level for right hand = 1.8 m/s²

Measured vibration level for left hand = 2.0 m/s²

Uncertainty Value (K) = 1.00 m/s²

Measured values were determined according to the procedures outlined in EN ISO 20643.

Slope Indicator

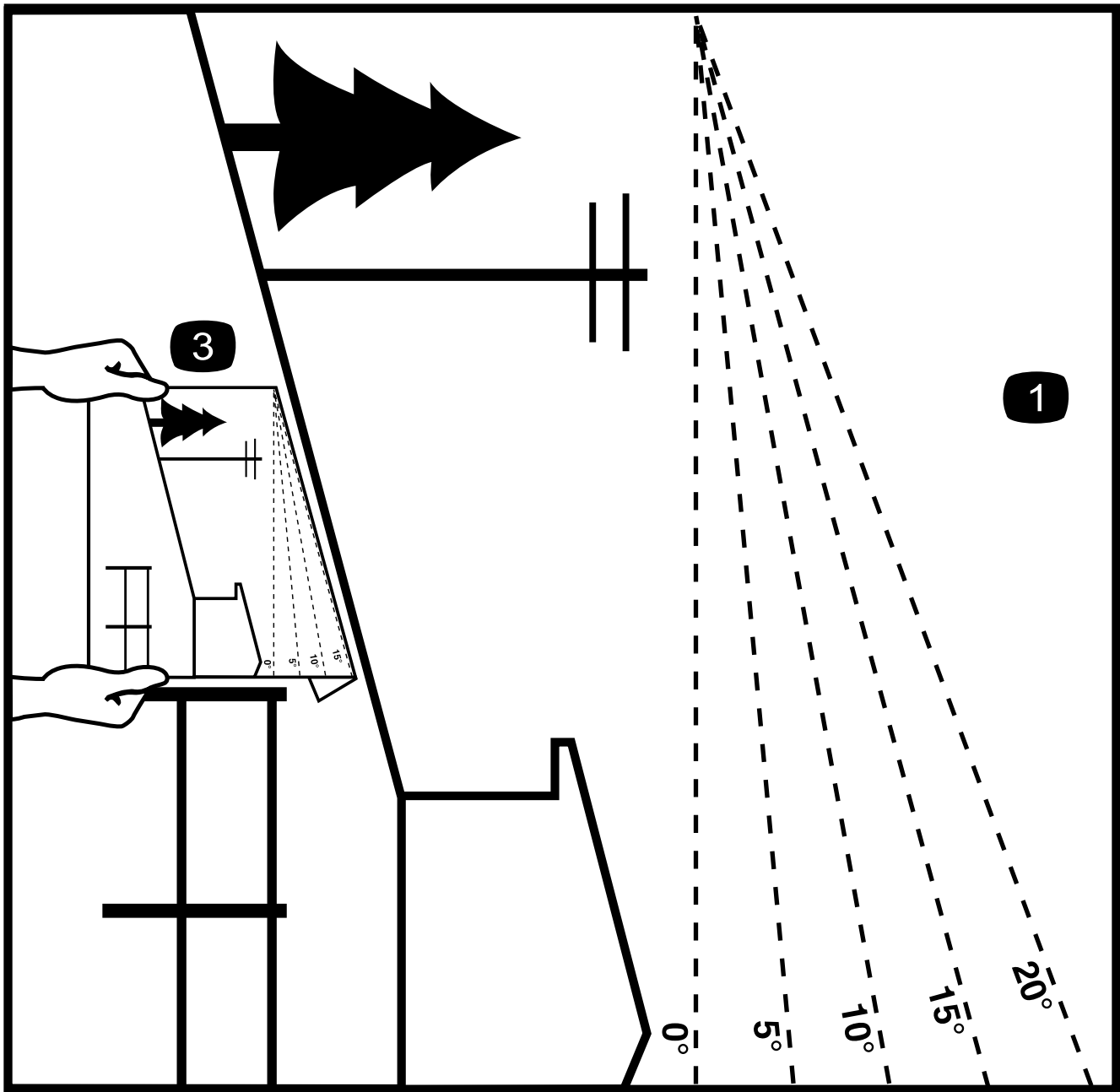

G011841

2

Figure 3

This page may be copied for personal use.

1. To determine the maximum slope you can safely operate the machine on, refer to the Slope Operation section. Use the slope indicator to determine the degree of slope of hills before operating. **Do not operate this machine on a slope greater than that specified in the Slope Operation section.** Fold along the appropriate line to match the recommended slope.
2. Align this edge with a vertical surface, a tree, building, fence pole, etc.
3. Example of how to compare slope with folded edge.

Safety and Instructional Decals



Safety decals and instructions are easily visible to the operator and are located near any area of potential danger. Replace any decal that is damaged or lost.

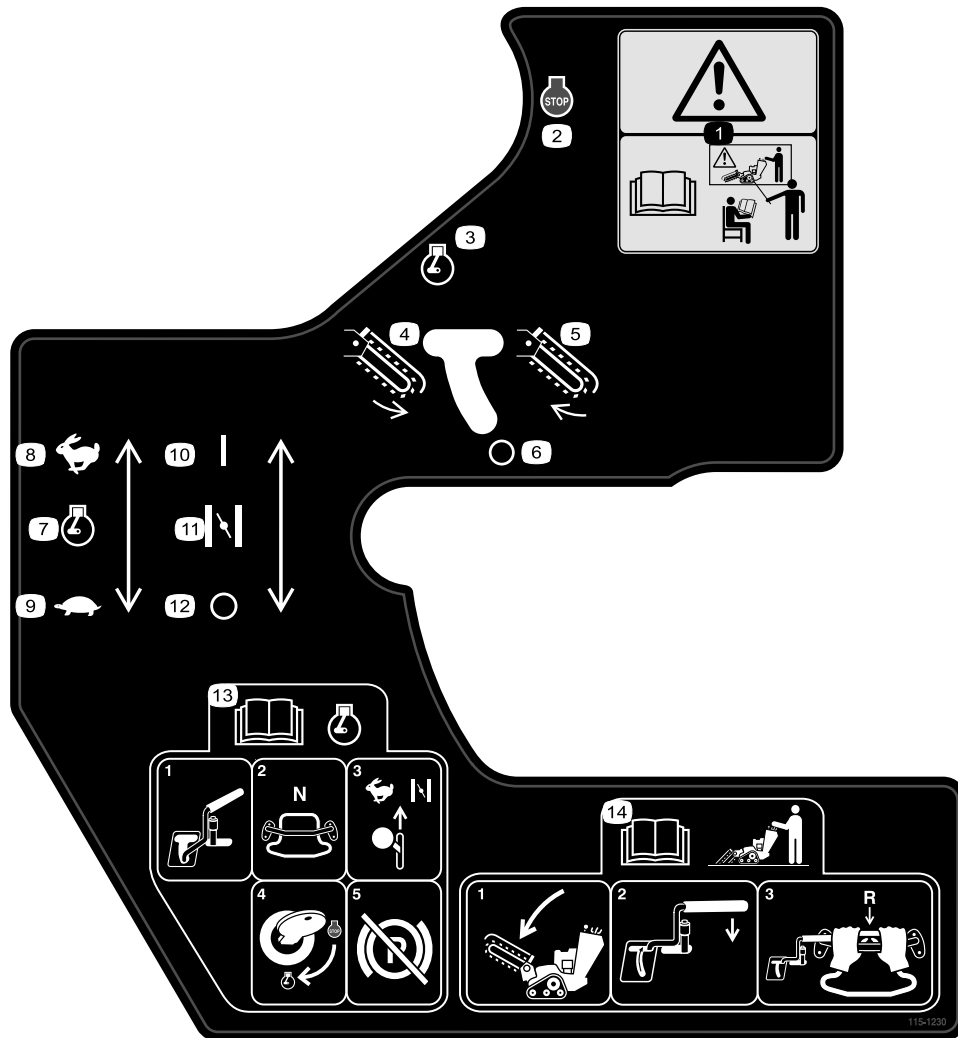

115-1230

1. Warning—do not operate this machine unless you are trained.
2. Engine—stop
3. Engine—run
4. Trencher chain—reverse
5. Trencher chain—forward
6. Trencher chain—off
7. Engine throttle
8. Fast
9. Slow
10. Choke
11. On/Closed
12. Off/Open
13. Read the *Operator's Manual* before starting the engine; to start the engine, move the trencher control lever into the Off position, place the traction control in Neutral, move the engine speed to Fast and the choke to On/Closed, turn the ignition key to run, and release the parking brake once the engine has started.
14. Read the *Operator's Manual* before operating the trencher; to operate the trencher, lower the boom, move the trencher control lever to the reference bar, pull the traction control rearward to move in reverse and dig the trench.

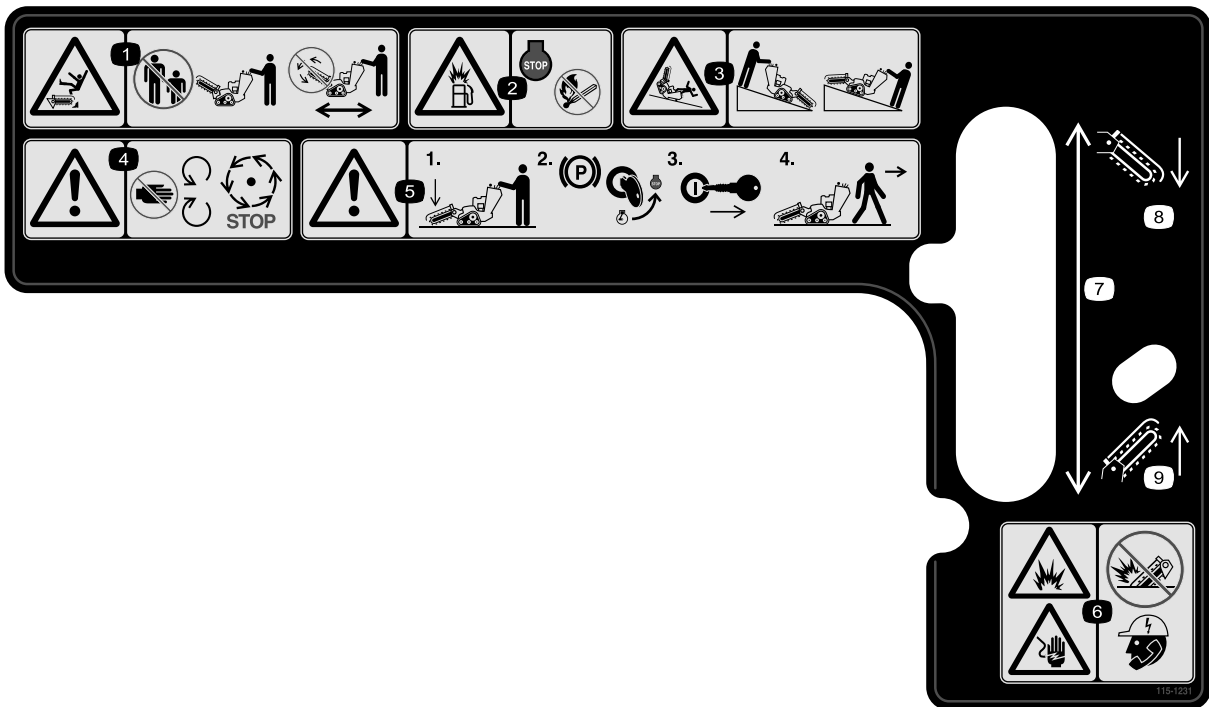

115-1231

- | | |
|---|--|
| <ol style="list-style-type: none"> 1. Cutting/dismemberment hazard of bystanders, trencher—keep bystanders a safe distance from the machine; do not operate the trencher chain while transporting the machine. 2. Explosion hazard, fueling—stop the engine and extinguish all flames when fueling. 3. Tipping/crushing hazard—lower the trencher head when operating on slopes. 4. Warning—stay away from moving parts; wait for all moving parts to stop 5. Warning—lower the boom, engage the parking brake and stop the engine, remove the ignition key, before leaving the machine. | <ol style="list-style-type: none"> 6. Explosion hazard; shock hazard—do not use machine near buried utility lines; contact the proper agencies before digging. 7. Boom elevation 8. Lower the boom 9. Raise the boom |
|---|--|

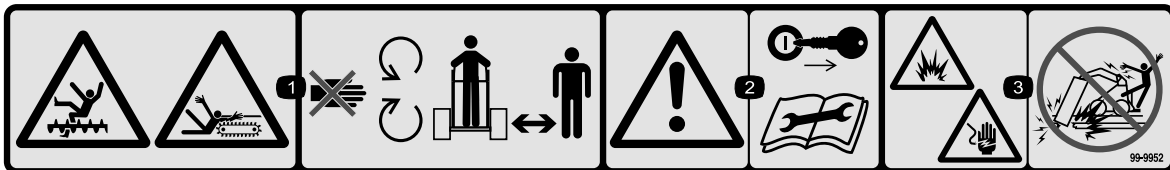

99-9952

1. Cutting hazard, chain and auger—stay away from moving parts and keep bystanders away from the machine.
2. Warning—stop the engine and remove the key before performing maintenance or repairs.
3. Explosion and/or electric shock hazard—do not dig in areas with buried gas or power lines.

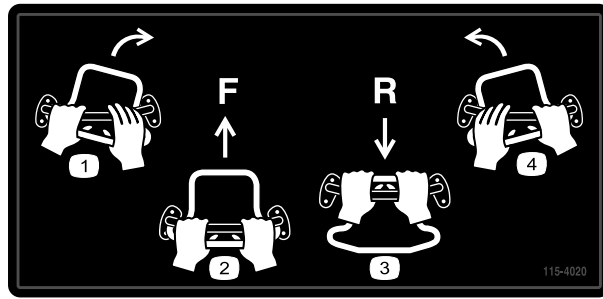

115-4020

1. Turn right
2. Forward
3. Reverse
4. Turn left

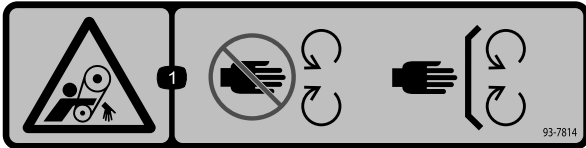

93-7814

1. Entanglement hazard, belt—stay away from moving parts.

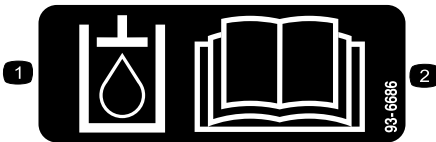

93-6686

1. Hydraulic oil
2. Read the *Operator's Manual*.

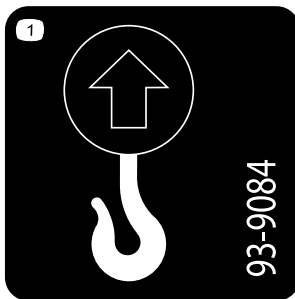

93-9084

1. Lift point
2. Tie-down point

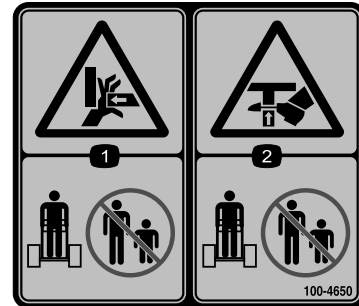

100-4650

1. Crushing hazard of hand—keep bystanders a safe distance from the machine.
2. Crushing hazard of foot—keep bystanders a safe distance from the machine.



107-8495

1. Parking brake

CALIFORNIA SPARK ARRESTER WARNING

Operation of this equipment may create sparks that can start fires around dry vegetation. A spark arrester may be required. The operator should contact local fire agencies for laws or regulations relating to fire prevention requirements. 117-2718

117-2718



Battery Symbols

Some or all of these symbols are on your battery

- | | |
|--|--|
| 1. Explosion hazard | 6. Keep bystanders a safe distance from the battery. |
| 2. No fire, open flame, or smoking. | 7. Wear eye protection; explosive gases can cause blindness and other injuries |
| 3. Caustic liquid/chemical burn hazard | 8. Battery acid can cause blindness or severe burns. |
| 4. Wear eye protection | 9. Flush eyes immediately with water and get medical help fast. |
| 5. Read the <i>Operator's Manual</i> . | 10. Contains lead; do not discard. |
-

Setup

Loose Parts

Use the chart below to verify that all parts have been shipped.

Procedure	Description	Qty.	Use
1	Boom (sold separately) Chain (sold separately)	1 1	Install the boom and chain.
2	No parts required	–	Check the fluid levels.
3	No parts required	–	Charge the battery.

1

Installing the Boom and Chain

Parts needed for this procedure:

1	Boom (sold separately)
1	Chain (sold separately)

Procedure

Important: There are several boom and chain size configurations available. Refer to your Authorized Service Dealer to obtain the appropriate boom and chain to meet your requirements.

1. Stop the engine and remove the key.
2. Remove the bolt, 2 saddle washers, and nut securing the spoils auger and remove the auger (Figure 4).

Note: Save the fasteners for future use.

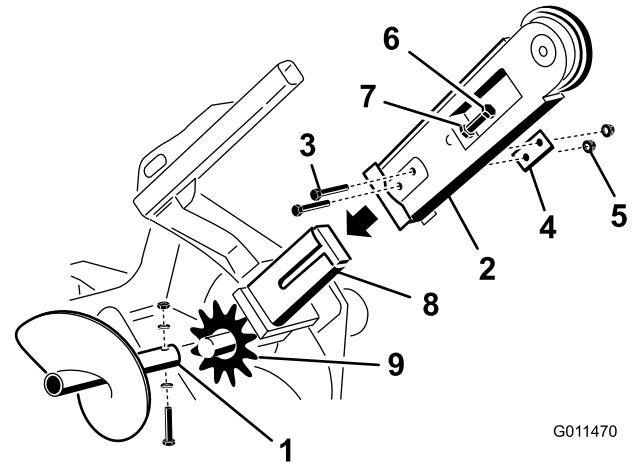

Figure 4

- | | |
|------------------|--------------------------|
| 1. Spoils auger | 6. Adjusting bolt |
| 2. Boom | 7. Jam nut |
| 3. Bolts | 8. Arm on the drive head |
| 4. Double washer | 9. Drive sprocket |
| 5. Nuts | |

3. Remove the 2 bolts, nuts, and double washers from the sides of the boom (Figure 4).
4. Loosen the adjusting bolt and jam nut (Figure 4).
5. Slide the boom over the arm on the drive head.
6. Install the 2 bolts, nuts, and double washers removed in step 3 through the boom and arm, but do not tighten them.
7. If the chain is not connected, connect the links by pressing or hammering the clevis pin supplied with the chain through the links.

Important: To avoid bending the chain links, place blocks under and between the links when hammering the clevis pin through.

8. Secure the clevis pin with the cotter pin supplied with the chain.
9. Loop the digging chain over the auger drive shaft and onto the drive sprocket, ensuring that the digging teeth point forward on the upper span.

10. Set the upper span of the chain into place on the trencher boom, then wrap the chain around the roller at the end of the boom.
11. Thread the adjustment bolt into the boom and turn it in until there is 3.8 to 6.3 cm (1-1/2 to 2-1/2 inches) of slack in the chain on the bottom span.
12. Thread the jam nut down the adjusting bolt and tighten it securely against the boom.
13. Torque the 2 bolts and nuts securing the boom to 183 to 223 N-m (135 to 165 ft-lb).
14. Install the spoils auger using the bolt, 2 saddle washer, and nut you removed previously.
15. Torque the bolt and nut to 101 N-m (75 ft-lb).

Product Overview

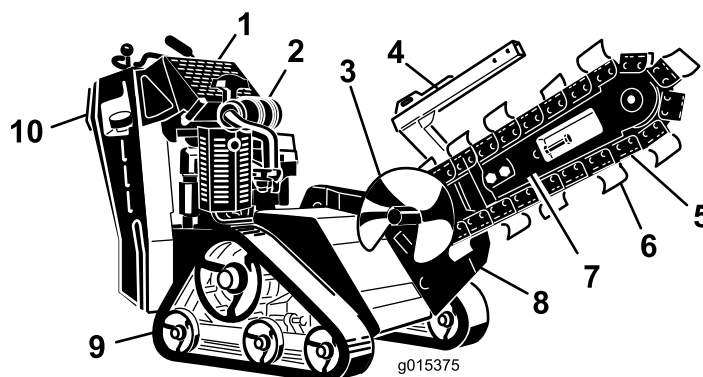

Figure 5

- | | | | |
|------------------|------------------|------------------|--------------------------|
| 1. Control panel | 4. Chain guard | 7. Boom | 10. Reverse safety plate |
| 2. Engine | 5. Chain | 8. Trencher head | |
| 3. Spoils auger | 6. Digging teeth | 9. Track | |

2

Checking Fluid Levels

No Parts Required

Procedure

Before starting the engine for the first time, check the engine oil and hydraulic fluid levels; refer to Checking the Engine-Oil Level (page 17) and Checking the Hydraulic Fluid Level (page 17) for more information.

3

Charging the Battery (Electric Start Models Only)

No Parts Required

Procedure

Charge the battery; refer to Charging the Battery (page 32) for more information.

Controls

Become familiar with all the controls (Figure 6) before you start the engine and operate the machine.

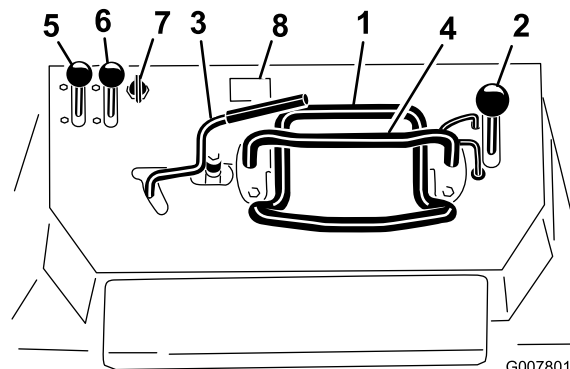

Figure 6

- | | |
|---------------------------|-------------------|
| 1. Traction control | 5. Throttle lever |
| 2. Boom elevation lever | 6. Choke lever |
| 3. Trencher control lever | 7. Key switch |
| 4. Reference bar | 8. Hour meter |

Key Switch, Model 22972

The key switch has 2 positions: Off and Run.

To start the engine, rotate the key to the Run position, then pull the recoil handle on the engine.

To stop the engine, rotate the key to the Off position.

Key Switch, Electric Start Models

The key switch has three positions: Off, Run, and Start.

To start the engine, rotate the key to the Start position. Release the key when engine starts and it will move automatically to the Run position.

To stop the engine, rotate the key to the Off position.

Throttle Lever

Move the control forward to increase the engine speed and rearward to decrease speed.

Choke Lever

Before starting a cold engine, move the choke lever forward. After the engine starts, regulate the choke to keep the engine running smoothly. As soon as possible, move the choke lever all the way rearward.

Note: A warm engine requires little or no choking.

Hour Meter

When the engine is off, the hour meter displays the number of hours of operation that have been logged on the machine.

Reference Bar

When driving the machine, use the reference bar as a handle and a leverage point for controlling the traction control and the trencher control lever. To ensure smooth, controlled operation, do not take both hands off of the reference bar while operating the machine.

Traction Control

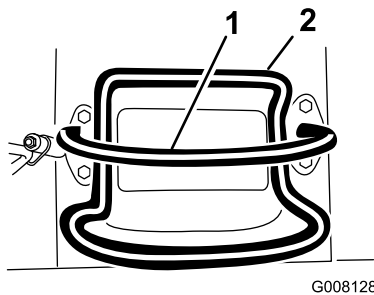

Figure 7

G008128

1. Reference bar (does not move to give you a reference point and a fixed handle to hold while operating the traction unit)
2. Traction control (moves to control the machine)

- To move forward, move the traction control forward (Figure 8).

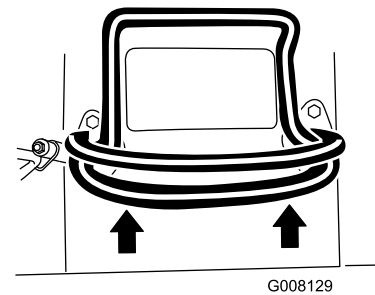

Figure 8

G008129

- To move rearward, move the traction control rearward (Figure 9). **When reversing, look behind for obstructions and keep your hands on the reference bar (Figure 7).**

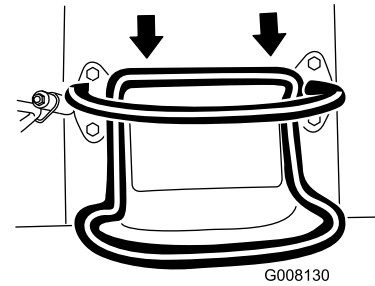

Figure 9

G008130

- To turn right, rotate the traction control clockwise (Figure 10).

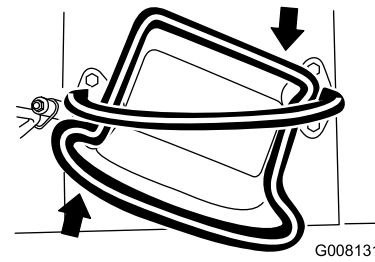

Figure 10

G008131

- To turn left, rotate the traction control counterclockwise (Figure 11).

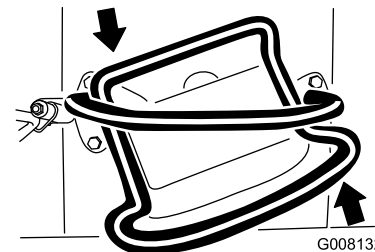

Figure 11

G008132

- To stop, release the traction control (Figure 7).

Note: The farther you move the traction control in any direction, the faster the machine will move in that direction.

Boom Elevation Lever

To lower the boom, slowly move the lever forward (Figure 12).

To raise the boom, slowly move the lever rearward (Figure 12).

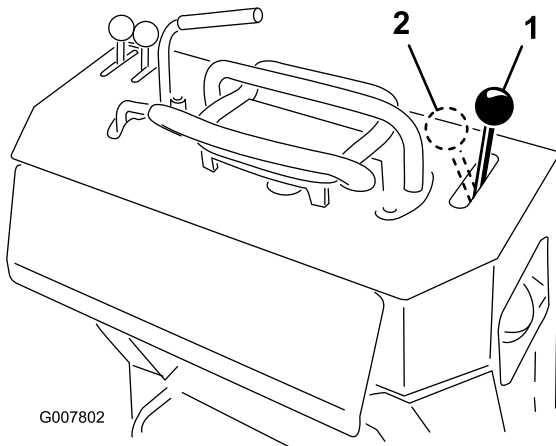

Figure 12

1. Lower the boom
2. Raise the boom

Boom Elevation Lock

The boom elevation lock secures the boom elevation lever so that you cannot push it forward. This helps to ensure that no one will accidentally lower the boom during maintenance. Secure the boom with the lock anytime you need to stop the machine with the boom raised.

To set the lock, lift up on it so it clears the hole in the control panel and swing it to the right in front of the boom elevation lever, pushing it down into the locked position (Figure 13).

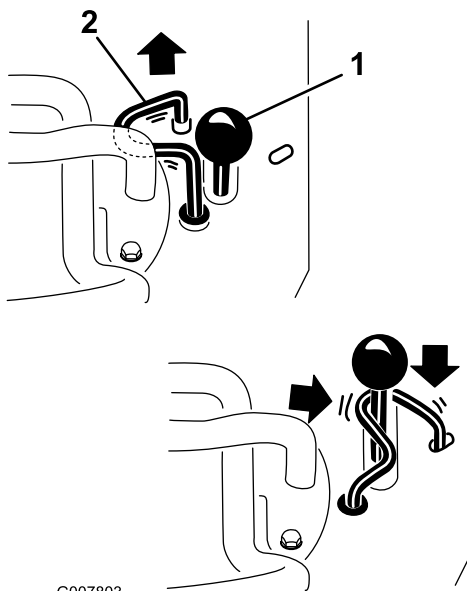

Figure 13

1. Boom elevation lever
2. Boom elevation lock

Trencher Control Lever

To dig with the trencher, rotate the lever rearward and pull it down to the reference bar (Figure 14, number 1).

To reverse the trencher head, rotate the lever rearward, then move it left into the upper slot (Figure 14, number 2).

If you release the lever, it will automatically return to the neutral position (Figure 14, number 3), stopping the chain.

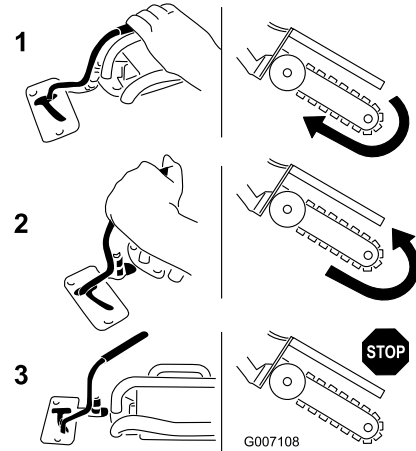

Figure 14

1. Forward
2. Reverse
3. Neutral

Parking Brake Lever

- To set the parking brake, pull the brake lever rearward and up (Figure 15).
- To release the brake, pull the lever rearward and then down (Figure 15).

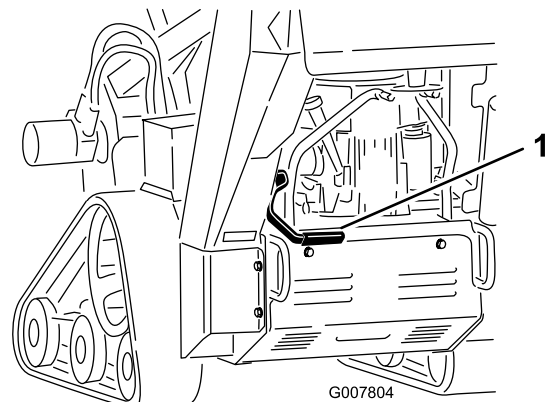

Figure 15

1. Parking brake lever (in the released position)

Specifications

Note: Specifications and design are subject to change without notice.

Width	86 cm (33.8 inches)
Length, with 70 cm (24 inch) boom	209.5 cm (82.5 inches)
Length, with 91.4 cm (36 inch) boom	235 cm (92.6 inches)
Length, with 122 cm (48 inch) boom (model 22974 only)	282.5 cm (111.2 inches)
Height	117 cm (46 inches)
Weight (model 22972)*	499 kg (1,100 lb)
Weight (model 22973)*	538 kg (1,185 lb)
Weight (model 22974)*	578 kg (1,208 lb)

* A 91.4 cm (36 inch) boom and chain will add about 27 kg (60 lb) to the listed weight.

Attachments/Accessories

A selection of Toro approved attachments and accessories is available for use with the machine to enhance and expand its capabilities. Contact your Authorized Service Dealer or Distributor or go to www.Toro.com for a list of all approved attachments and accessories.

Operation

Note: Determine the left and right sides of the machine from the normal operating position.

Important: Before operating, check the fuel and oil level, and remove debris from the machine. Also, ensure that the area is clear of people and debris. You should also know and have marked the locations of all utility lines.

Recommended Fuel

- For best results, use only clean, fresh (less than 30 days old), unleaded gasoline with an octane rating of 87 or higher ((R+M)/2 rating method).
- **Ethanol:** Gasoline with up to 10% ethanol (gasohol) or 15% MTBE (methyl tertiary butyl ether) by volume is acceptable. Ethanol and MTBE are not the same. Gasoline with 15% ethanol (E15) by volume is not approved for use. **Never use** gasoline that contains more than 10% ethanol by volume, such as E15 (contains 15% ethanol), E20 (contains 20% ethanol), or E85 (contains 85% ethanol). Using unapproved gasoline may cause performance problems and/or engine damage which may not be covered under warranty.
- **Do not** use gasoline containing methanol.
- **Do not** store fuel either in the fuel tank or fuel containers over the winter unless a fuel stabilizer is used.
- **Do not** add oil to gasoline.

▲ DANGER

In certain conditions, gasoline is extremely flammable and highly explosive. A fire or explosion from gasoline can burn you and others and can damage property.

- **Fill the fuel tank outdoors, in an open area, when the engine is cold. Wipe up any gasoline that spills.**
- **Never fill the fuel tank inside an enclosed trailer.**
- **Do not fill the fuel tank completely full. Add gasoline to the fuel tank until the level is 6 to 13 mm (1/4 to 1/2 inch) below the bottom of the filler neck. This empty space in the tank allows gasoline to expand.**
- **Never smoke when handling gasoline, and stay away from an open flame or where gasoline fumes may be ignited by a spark.**
- **Store gasoline in an approved container and keep it out of the reach of children. Never buy more than a 30-day supply of gasoline.**
- **Do not operate without entire exhaust system in place and in proper working condition.**

▲ DANGER

In certain conditions during fueling, static electricity can be released causing a spark which can ignite the gasoline vapors. A fire or explosion from gasoline can burn you and others and can damage property.

- Always place gasoline containers on the ground away from your vehicle before filling.
- Do not fill gasoline containers inside a vehicle or on a truck or trailer bed because interior carpets or plastic truck bed liners may insulate the container and slow the loss of any static charge.
- When practical, remove gas-powered equipment from the truck or trailer and refuel the equipment with its wheels on the ground.
- If this is not possible, then refuel such equipment on a truck or trailer from a portable container, rather than from a gasoline dispenser nozzle.
- If a gasoline dispenser nozzle must be used, keep the nozzle in contact with the rim of the fuel tank or container opening at all times until fueling is complete.

Checking the Engine-Oil Level

Service Interval: Before each use or daily

1. Park the machine on a level surface, lower the boom, and stop the engine.
2. Remove the key and allow the engine to cool.
3. Clean around the oil dipstick (Figure 16).

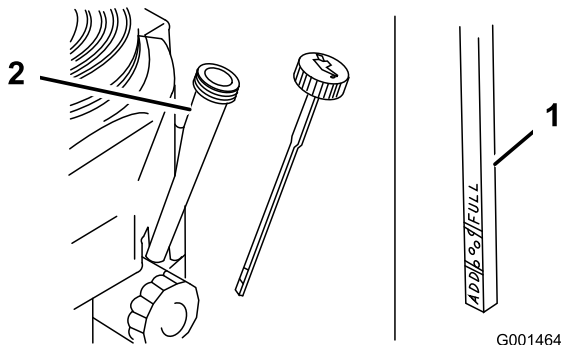

Figure 16

- | | |
|--------------------|--------------|
| 1. Oil filler hole | 3. Full mark |
| 2. Oil dipstick | 4. Add mark |

4. Remove the dipstick and wipe the end clean (Figure 16).
5. Slide the dipstick fully into the dipstick tube without threading it into the filler neck (Figure 16).
6. Pull the dipstick out and look at the end. The oil should be between the Add and Full marks (Figure 16).

7. If the oil is below the Add mark, add 10w30 engine oil to the filler hole, checking the level frequently with the dipstick, until the oil level reaches the Full mark.
8. Replace the dipstick.

Checking the Hydraulic Fluid Level

Service Interval: Every 25 hours

Hydraulic Tank Capacity: 23 L (6 US gallons)

Refer to Changing the Hydraulic Fluid (page 38) for hydraulic fluid specifications.

1. Park the machine on a level surface and lower the boom.
2. Stop the engine, remove the key, and allow the engine to cool.
3. Look into the glass bubble on the right side of the machine. If you cannot see hydraulic fluid in the bubble, continue this procedure to add fluid.

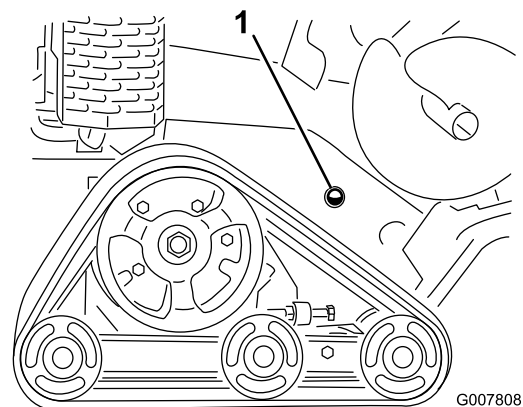

Figure 17

1. Hydraulic fluid check bubble

4. Remove the cover plate; refer to Removing the Cover Plate (page 23).
5. Clean the area around the filler neck of the hydraulic tank and remove the cap and filter from the filler neck using a socket (Figure 18).

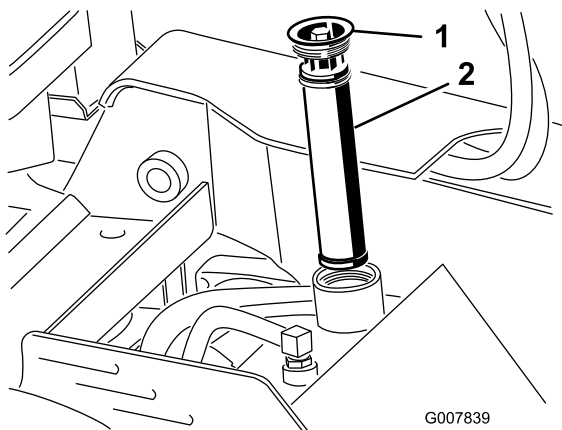

Figure 18

1. Filler neck cap 2. Hydraulic fluid filter

-
6. If the level is low, add fluid until it is visible in the glass bubble.
 7. Install the cap and filter on the filler neck and torque bolt on top to 13 to 15.5 N-m (110 to 140 inch-lb).

Starting and Stopping the Engine

Starting the Engine

1. Move the throttle lever midway between Slow and Fast positions (Figure 19).

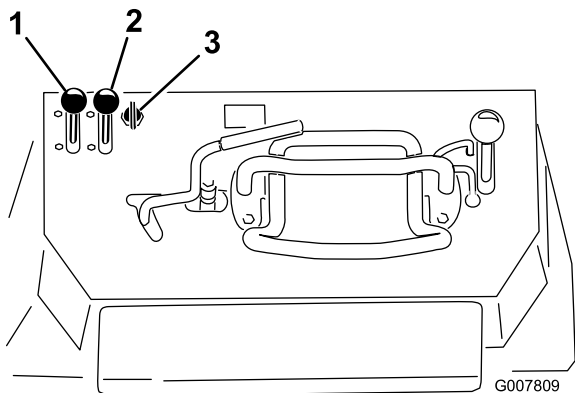

Figure 19

1. Throttle lever
2. Choke lever
3. Key

2. Move the choke lever to the On position (Figure 19).

Note: A warm or hot engine may not require choking.

3. Start the engine as follows for your model:

- For model 22972, turn the key to the On position then pull the recoil handle on top of the engine.
- For an electric start model, turn the key to the On position (Figure 19). When the engine starts, release the key.

Important: Do not engage the starter for more than 10 seconds at a time. If the engine fails to start, allow a 30 second cool-down period between attempts. Failure to follow these instructions can burn out the starter motor.

4. Gradually move the choke lever to the Off position (Figure 19). If the engine stalls or hesitates, engage the choke again until the engine warms up.
5. Move the throttle lever to the desired setting (Figure 19).

Important: If the engine is run at high speeds when the hydraulic system is cold (i.e., when the ambient air temperature is near freezing or lower), hydraulic system damage could occur. When starting the engine in cold conditions, allow the engine to run in the middle throttle position for 2 to 5 minutes before moving the throttle to fast (rabbit).

Note: If the outdoor temperature is below freezing, store the machine in a garage to keep it warmer and aid in starting.

Stopping the Engine

1. Move the throttle lever to the Slow position (Figure 19).
2. Lower the boom (Figure 20).

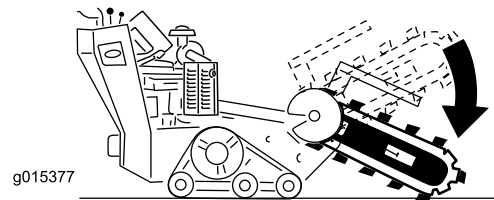
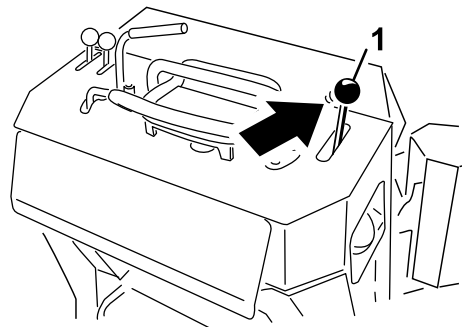

Figure 20

3. Turn the key off (Figure 19).

Note: If the engine has been working hard or is hot, let it idle for a minute before turning the ignition key off. This helps cool the engine before it is stopped. In an emergency, the engine may be stopped immediately.

4. Remove the key.

Stopping the Machine

To stop the machine, release the traction control, move the throttle lever to slow (turtle), lower the boom to the ground, and stop the engine. Set the parking brake and remove the key.

⚠ CAUTION

A child or untrained bystander could attempt to operate the machine and be injured.

Remove the key from the switch when leaving the machine, even if just for a few seconds.

Moving a Non-functioning Machine

Important: Do not tow or pull the machine without first opening the tow valves, or the hydraulic system will be damaged.

1. Stop the engine.
2. Remove the bottom shield.
3. Using a wrench, turn the tow valves on the hydraulic pumps twice counter-clockwise (Figure 21).

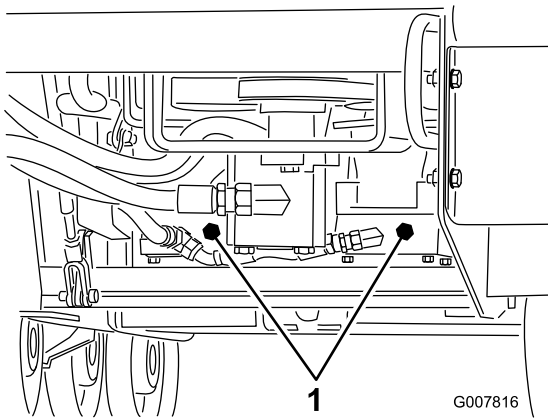

Figure 21

1. Tow valves

4. Install the bottom shield and tow the machine as required.
5. When the machine has been repaired, close the tow valves before operating it.

Digging a Trench

1. Start the engine, raise the boom, set the throttle lever to the Fast position, and move the machine over the area to be trenched.
2. Pull the trencher control lever to the reference bar to engage the trencher.
3. Slowly lower the boom and chain into the ground.

Note: To achieve the maximum depth, you may need to lower the boom as far into the ground as it will go with the chain running. Then, stop the chain and lower it fully. Start the chain again and resume operation.

4. Once the trencher boom is in the ground at a 45 to 60 degree angle, slowly move the traction unit rearward to extend the trench.

Note: If you move too fast, the trencher will stall. If it stalls, raise it slightly, slowly drive forward, or reverse the chain direction momentarily.

5. When finished, raise the boom out of the trench, then stop the trencher.

Securing the Machine for Transport

When transporting the machine on a trailer, always use the following procedure:

Important: Do not operate or drive the machine on roadways.

1. Stop the engine.
2. Lower the boom.

3. Secure the machine to the trailer with chains or straps using the tie-down/lift loops at the front and rear of the machine (Figure 22 and Figure 23). Refer to your local ordinances for trailer and tie-down requirements.

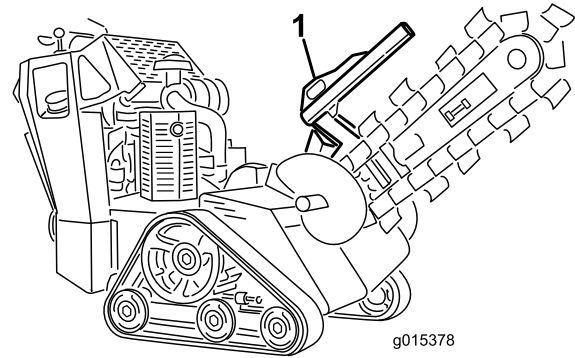

Figure 22

1. Front tie-down loop

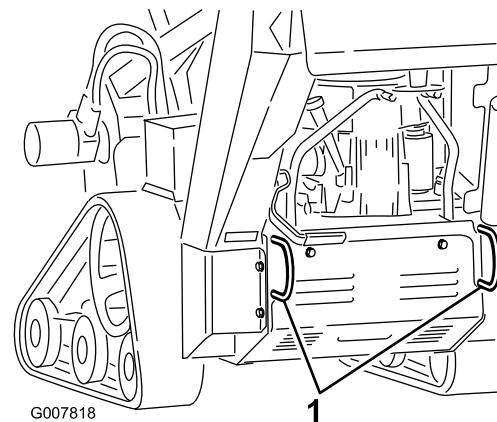

Figure 23

1. Rear tie-down loops

Lifting the Machine

You can lift the machine using the tie-down/lift loops as lift points (Figure 22 and Figure 23).

Operating Tips

- Clean the area of trash, branches and rocks before trenching to prevent equipment damage.
- Always begin trenching with the slowest ground speed possible. Increase speed if conditions permit. If the chain speed slows down, reduce ground speed to keep the chain moving at its fastest rate. Do not spin the tracks while trenching.
- Always use full throttle (maximum engine speed) when trenching.
- Always trench backwards (i.e., in reverse).
- Trench with the chain at a 45° to 60° angle for best results.
- You will be able to dig a trench faster by controlling the depth with periodic adjustments of the boom.
- If the trencher binds in the soil, reverse the chain direction. Once the chain is loose, change chain directions and continue trenching.
- If you need the finished trench to be cleaner than what is possible with the trencher, you can purchase a crumber from your dealer. The crumber mounts onto the trencher head and scrapes the trench clean as you dig.
- To improve the quality of trenches less than 60.9 cm (24 inches) deep, use a 60.9 cm (24 inch) boom.
- If the lift speed of the machine is too slow or too fast, adjust the bolt indicated in Figure 24.

Soil Type	Recommended Chain Type
Sandy	Soil chain (re-configure with extra teeth for added digging speed; refer to your Authorized Service Dealer)
Sandy Loam/Loam/Loamy Clay	Soil chain
Wet, sticky clay	Soil chain
Hard soils: dry clay and compacted soils	Combination chain
Rocky soil/gravel	Rock chain

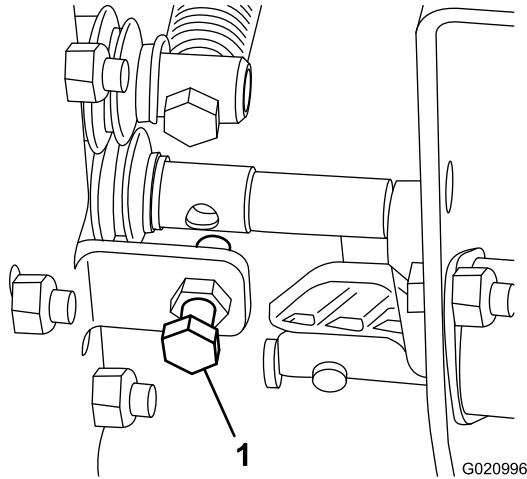

Figure 24

1. Lift speed adjustment bolt

-
- Use the correct chain for the ground conditions, as listed in the following table:

Maintenance

Note: Determine the left and right sides of the machine from the normal operating position.

Recommended Maintenance Schedule(s)

Maintenance Service Interval	Maintenance Procedure
After the first 8 hours	<ul style="list-style-type: none"> • Change the engine oil.
After the first 50 hours	<ul style="list-style-type: none"> • Check and adjust the track tension.
Before each use or daily	<ul style="list-style-type: none"> • Check the engine-oil level. • Grease the machine. (Grease immediately after every washing.) • Check the engine oil level. • Check the condition of and clean the tracks. • Check the condition of the digging teeth and replace any that are worn or damaged. • Remove debris from the machine. • Check for loose fasteners.
Every 25 hours	<ul style="list-style-type: none"> • Check the hydraulic fluid level. • Clean the foam air cleaner element. • Check the battery electrolyte level. • Check the digging chain for excessive wear and proper tension.
Every 40 hours	<ul style="list-style-type: none"> • Grease the trencher housing.
Every 50 hours	<ul style="list-style-type: none"> • Check the paper air cleaner element.
Every 100 hours	<ul style="list-style-type: none"> • Change the engine oil. • Check the spark plugs. • Check and adjust the track tension. • Check the hydraulic lines for leaks, loose fittings, kinked lines, loose mounting supports, wear, weather, and chemical deterioration and repair if necessary.
Every 200 hours	<ul style="list-style-type: none"> • Replace the paper air cleaner element. • Change the oil filter. • Replace the fuel filter. • Replace the hydraulic filter.
Every 250 hours	<ul style="list-style-type: none"> • Replace the primary air filter and check the condition of the safety filter (Model 22974) • Check and grease the road wheels.
Every 400 hours	<ul style="list-style-type: none"> • Change the hydraulic fluid.
Every 1,500 hours	<ul style="list-style-type: none"> • Replace all moving hydraulic hoses.
Yearly or before storage	<ul style="list-style-type: none"> • Check and adjust the track tension. • Check and adjust the chain tension. • Touch up chipped paint

Important: Refer to your *Engine Operator's Manual* for additional maintenance procedures.

⚠ CAUTION

If you leave the key in the ignition switch, someone could accidentally start the engine and seriously injure you or other bystanders.

Remove the key from the ignition and disconnect the wire from the spark plug before you do any maintenance. Set the wire aside so that it does not accidentally contact the spark plug.

Premaintenance Procedures

Before opening any of the covers, stop the engine, remove the key, and allow the engine to cool.

Important: The fasteners on the covers of this machine are designed to remain on the cover after removal. Loosen all of the fasteners on each cover a few turns so that the cover is loose but still attached, then go back and loosen them until the cover comes free. This will prevent you from accidentally stripping the bolts free of the retainers.

Removing the Cover Plate

1. Lower the boom, stop the engine, and remove the key.

⚠ WARNING

There is a belt under the cover that is moving when the machine is running and can catch fingers, hands, loose hair, and clothing, causing serious injury, amputation, or death.

Always stop the engine and wait for all moving parts to stop before removing the cover.

2. Loosen the bolt at the rear of the cover plate.
3. Loosen the 3 bolts securing the cover plate to the frame sequentially until the cover is loose (Figure 25).

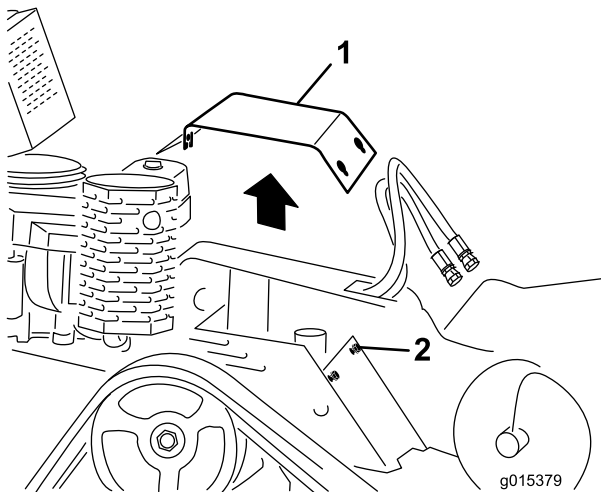

Figure 25

1. Cover plate
2. Bolts

4. Pull up on the rear of the cover plate until it clears the engine and then pull it off over the bolt heads and off of the machine.

Installing the Cover Plate

1. Lower the boom, stop the engine, and remove the key.
2. Slide the cover plate into place and secure it with the 3 bolts you loosened previously (Figure 25).

Removing the Bottom Shield

1. Lower the boom, stop the engine, and remove the key.
2. Loosen the 2 bolts securing the bottom shield sequentially until the shield is free (Figure 26).

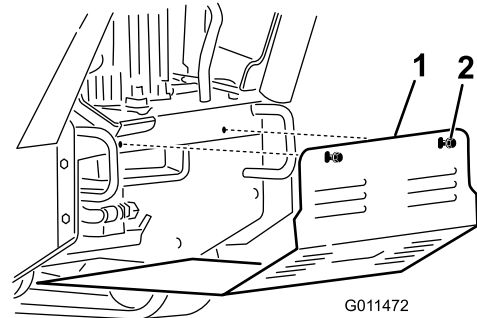

Figure 26

1. Bottom shield
2. Bolts

3. Pull the shield back and out of the machine.

Installing the Bottom Shield

1. Lower the boom, stop the engine, and remove the key.
2. Slide the bottom shield into the machine so that it rests on all 4 tabs (Figure 26).

Note: You may need to lift up on the bottom shield to ensure that it rests on the front tabs.

3. Secure the shield with the bolts you loosened previously.

Lubrication

Greasing the Machine

Service Interval: Before each use or daily (Grease immediately after every washing.)

Grease Type: General-purpose grease.

1. Lower the boom and stop the engine. Remove the key.
2. Clean the grease fittings with a rag.
3. Connect a grease gun to each fitting (Figure 27 through Figure 30).
4. Pump grease into the fittings until grease begins to ooze out of the bearings (approximately 3 pumps).
5. Wipe up any excess grease.

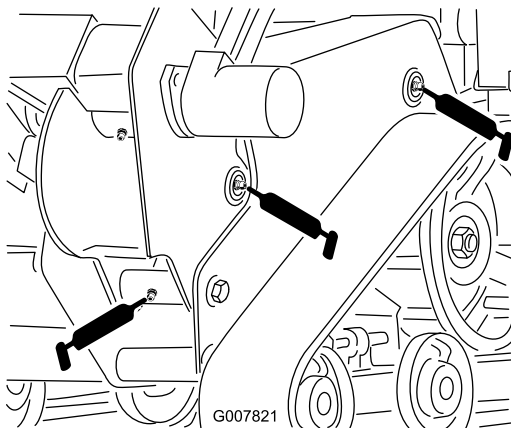

Figure 27

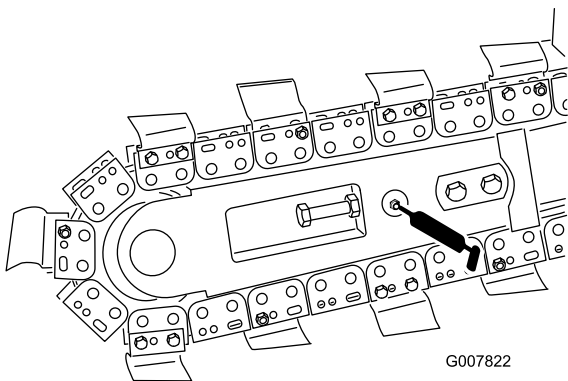

Figure 28

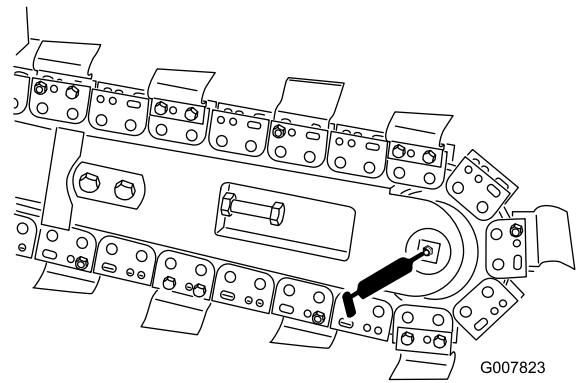

Figure 29

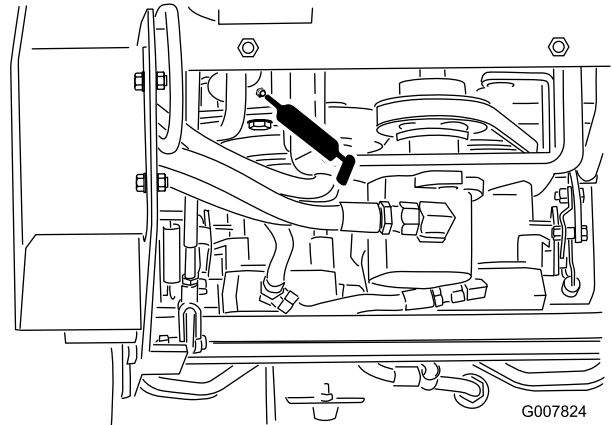

Figure 30

Greasing the Trencher Housing

Service Interval: Every 40 hours

Grease Type: General-purpose grease.

1. Lower the boom and stop the engine. Remove the key.
2. Clean the trencher housing grease fitting with a rag and connect a grease gun to it (Figure 31).

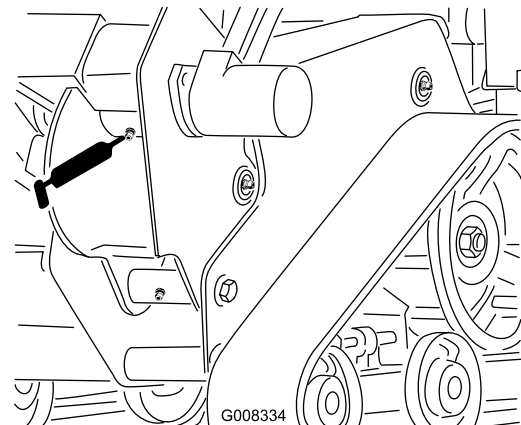

Figure 31

3. Pump grease into the fitting until grease comes out of the grease valve located next to the fitting.
4. Wipe up any excess grease.

Engine Maintenance

Servicing the Air Cleaner (Models 22972 and 22973)

Service Interval: Every 25 hours—Clean the foam air cleaner element.

Every 50 hours—Check the paper air cleaner element.

Every 200 hours/Yearly (whichever comes first)—Replace the paper air cleaner element.

Inspect the foam and paper elements and replace them if they are damaged or excessively dirty.

Note: Service the air cleaner more frequently (every few operating hours) if the operating conditions are extremely dusty or sandy.

Important: Do not oil the foam or paper element.

Removing the Foam and Paper Elements

1. Lower the boom and set the parking brake.
2. Stop the engine, remove the key, and wait for all moving parts to stop before leaving the operating position.
3. Clean around the air cleaner to prevent dirt from getting into the engine and causing damage (Figure 32).
4. Unscrew the cover knobs and remove the air cleaner cover (Figure 32).
5. Unscrew the hose clamp and remove the air cleaner assembly (Figure 32).
6. Carefully pull the foam element off the paper element (Figure 32).

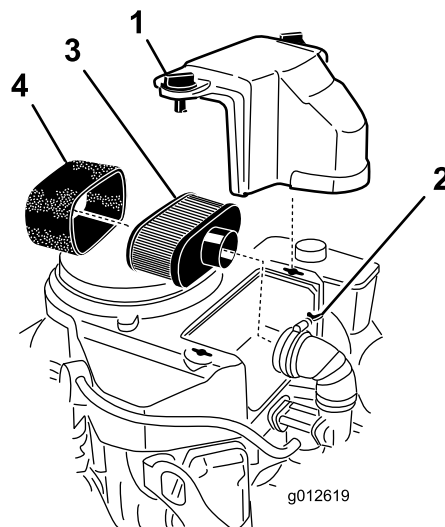

Figure 32

- | | |
|---------------|------------------|
| 1. Cover | 3. Paper element |
| 2. Hose clamp | 4. Foam element |

Cleaning the Foam Air Cleaner Element

1. Wash the foam element in liquid soap and warm water. When the element is clean, rinse it thoroughly.
2. Dry the element by squeezing it in a clean cloth.

Important: Replace the foam element if it is torn or worn.

Servicing the Paper Air Cleaner Element

1. Clean the paper element by tapping gently to remove dust. If it is very dirty, replace the paper element with a new one (Figure 32).
2. Inspect the element for tears, an oily film, or damage to the rubber seal.
3. Replace the paper element if it is damaged.

Do not clean the paper filter. Replace it after 200 operating hours (Figure 32). Inspect the element for tears, an oily film, or damage to the rubber seal, and replace it if it is damaged.

Installing the Foam and Paper Elements

Important: To prevent engine damage, always operate the engine with the complete foam and paper air cleaner assembly installed.

1. Carefully slide the foam element onto the paper air cleaner element (Figure 32).
2. Place the air cleaner assembly onto the air cleaner base or hose and secure it (Figure 32).
3. Place the air cleaner cover into position and tighten the cover knobs (Figure 32).

Servicing the Air Cleaner (Model 22974)

Service Interval: Every 250 hours

Servicing the Air Cleaner Cover and Body

1. Stop the engine and remove the key.
2. Check the air cleaner body for damage which could cause an air leak. Check the whole intake system for leaks, damage, or loose hose clamps. Replace or repair and damaged components.
3. Release the latches on the air cleaner and pull the air cleaner cover off of the air cleaner body (Figure 33).

Important: Do not remove the air filters yet.

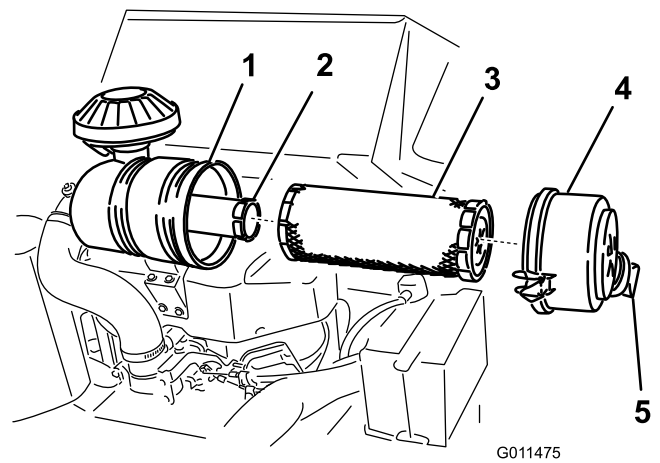

Figure 33

- | | |
|--------------------|----------------------|
| 1. Air filter body | 4. Air cleaner cover |
| 2. Safety filter | 5. Dust cap |
| 3. Primary filter | |

4. Squeeze the dust cap sides to open it and knock the dust out.
5. Clean the inside of the air cleaner cover with compressed air.

Replacing the Filters

1. Gently slide the primary filter out of the air cleaner body (Figure 33). Avoid knocking the filter into the side of the body.

Important: Do not attempt to clean the primary filter.

2. Check the condition of the safety filter without removing it. If it is dirty or damaged, replace it.

Important: Never attempt to clean the safety filter.

3. Inspect the new filter(s) for damage by looking into the filter while shining a bright light on the outside of the filter. Holes in the filter will appear as bright spots. Inspect the element for tears, an oily film, or damage to the rubber seal. If the filter is damaged do not use it.
4. If you are replacing the safety filter, carefully slide the new filter into the filter body (Figure 33).

Important: To prevent engine damage, always operate the engine with both air filters and cover installed.

5. Carefully slide the primary filter over the safety filter (Figure 33). Ensure that it is fully seated by pushing on the outer rim of the filter while installing it.

Important: Do not press on the soft inside area of the filter.

6. Install the air cleaner cover with the dust cap oriented as shown in Figure 33 and secure the latches.

Servicing the Engine Oil

Service Interval: After the first 8 hours—Change the engine oil.

Before each use or daily—Check the engine oil level.

Every 100 hours—Change the engine oil.

Every 200 hours—Change the oil filter.

Note: Change the oil more frequently when the operating conditions are extremely dusty or sandy.

Oil Type: Detergent oil (API service SF, SG, SH, or SJ)

Crankcase Capacity: 1.7 liters (58 ounces) with the filter removed; 1.5 liters (51 ounces) without the filter removed

Viscosity: Refer to the table (Figure 34).

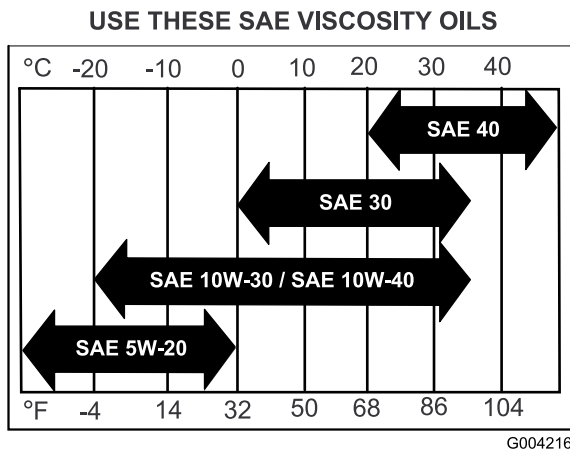

Figure 34

Checking the Engine Oil Level

1. Park the machine on a level surface.
2. Lower the boom and set the parking brake.
3. Stop the engine, remove the key, and wait for all moving parts to stop before leaving the operating position.
4. Clean around the oil dipstick (Figure 35) so that dirt cannot fall into the filler hole and damage the engine.

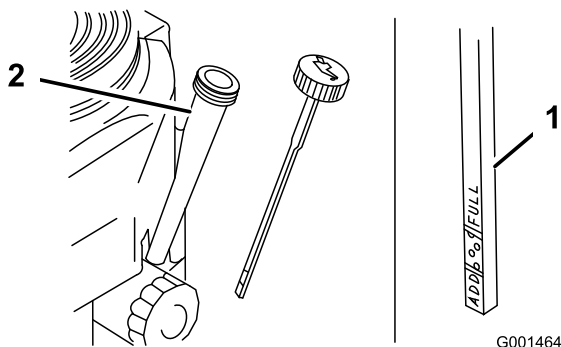

Figure 35

1. Oil dipstick
2. Filler tube

5. Unscrew the oil dipstick and wipe the end clean (Figure 35).
6. Slide the oil dipstick fully into the filler tube, but do not thread onto tube (Figure 35).
7. Pull the dipstick out and look at the end. If the oil level is low, slowly pour only enough oil into the filler tube to raise the level to the Full mark.

Important: Do not overfill the crankcase with oil and run the engine; engine damage can result.

Changing the Oil

1. Start the engine and let it run 5 minutes. This warms the oil so it drains better.
2. Park the machine so that the drain side is slightly lower than the opposite side to ensure that the oil drains completely.
3. Lower the boom and set the parking brake.
4. Stop the engine, remove the key, and wait for all moving parts to stop before leaving the operating position.
5. Place a pan below the drain hose.

Note: Rotate the oil drain valve to allow oil to drain (Figure 36).

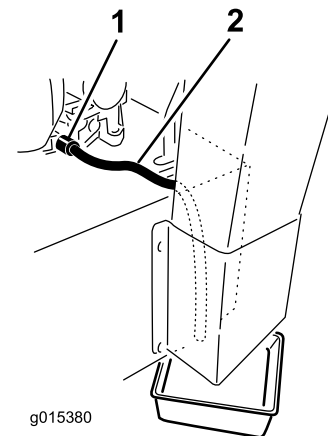

Figure 36

1. Oil drain valve
2. Oil drain hose

6. When oil has drained completely, close the drain valve.
7. Dispose of the used oil at a recycling center
8. Slowly pour approximately 80% of the specified oil into the filler tube (Figure 35).
9. Check the oil level; refer to Checking the Engine-Oil Level (page 17).
10. Slowly add the additional oil to bring it to the Full mark.

Changing the Oil Filter

1. Drain the oil from the engine; refer to Changing the Oil (page 27).

- Remove the old filter (Figure 37).

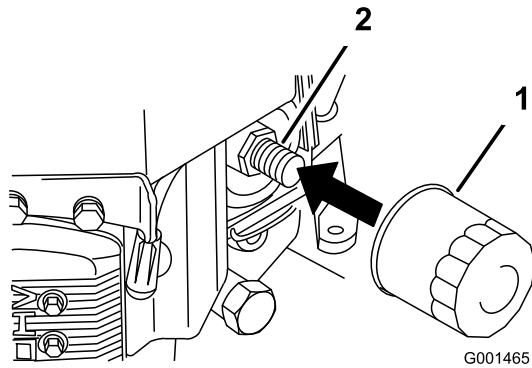

Figure 37

- Oil filter
- Adapter

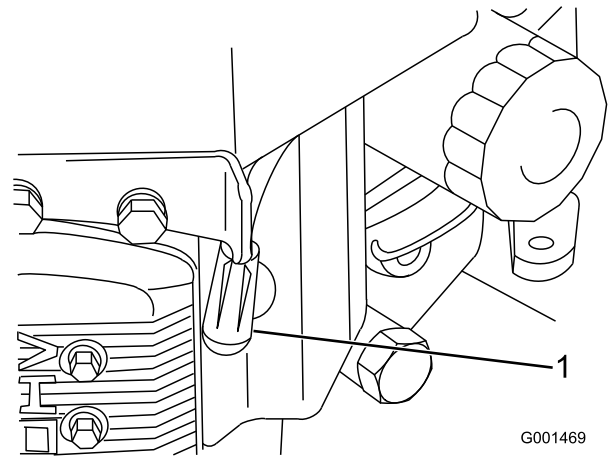

Figure 38

- Spark-plug wire/spark plug

- Apply a thin coat of new oil to the rubber gasket on the replacement filter (Figure 37).
- Install the replacement oil filter to the filter adapter, turn the oil filter clockwise until the rubber gasket contacts the filter adapter, then tighten the filter an additional 3/4 turn (Figure 37).
- Fill the crankcase with the proper type of new oil; refer to Servicing the Engine Oil (page 27).
- Run the engine for about 3 minutes, stop the engine, and check for oil leaks around the oil filter and drain valve.
- Check the engine oil level and add oil if needed.
- Wipe up any spilled oil.

- Clean around the spark plug to prevent dirt from falling into the engine and potentially causing damage.

Note: The heat shield may interfere on the right side; remove it if necessary and replace it when finished.

- Remove the spark plug and the metal washer.

Checking the Spark Plug

- Look at the center of the spark plug (Figure 39). If you see light brown or gray on the insulator, the engine is operating properly. A black coating on the insulator usually means that the air cleaner is dirty.
- If needed, clean the spark plug with a wire brush to remove carbon deposits.

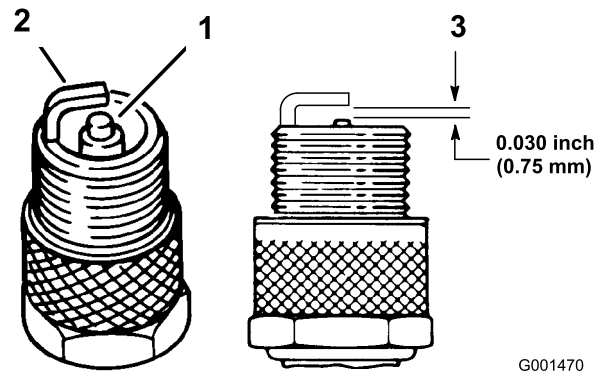

Figure 39

- Center electrode insulator
- Side electrode
- Air gap (not to scale)

Important: Always replace the spark plug when it has worn electrodes, an oily film on it, or has cracks in the porcelain.

- Check the gap between the center and side electrodes (Figure 39).

Note: Bend the side electrode (Figure 39) if the gap is not correct.

Servicing the Spark Plug

Service Interval: Every 100 hours—Check the spark plugs.

Ensure that the air gap between the center and side electrodes is correct before installing the spark plug. Use a spark plug wrench for removing and installing the spark plug and a gapping tool/feeler gauge to check and adjust the air gap. Install a new spark plug if necessary.

Type: NGK BPR4Es or equivalent; Air Gap: 0.75 mm (0.030 inches)

Removing the Spark Plug

- Lower the boom and set the parking brake.
- Stop the engine, remove the key, and wait for all moving parts to stop before leaving the operating position.
- Disconnect the wire from the spark plug (Figure 38).

Installing the Spark Plug

1. Install the spark plug and the metal washer. Ensure that the air gap is set correctly.
2. Tighten the spark plug to 22 N-m (16 ft-lb).
3. Connect the wire to the spark plug (Figure 39).

Fuel System Maintenance

Draining the Fuel Tank

⚠ DANGER

In certain conditions, gasoline is extremely flammable and highly explosive. A fire or explosion from gasoline can burn you and others and can damage property.

- Drain gasoline from the fuel tank when the engine is cold. Do this outdoors in an open area. Wipe up any gasoline that spills.
- Never smoke when draining gasoline, and stay away from an open flame or where a spark may ignite the gasoline fumes.

1. Park the machine on a level surface, to ensure that the fuel tank drains completely.
2. Lower the boom and set the parking brake.
3. Stop the engine, remove the key, and wait for all moving parts to stop before leaving the operating position.
4. Turn the fuel shutoff valve to the closed position (Figure 40).

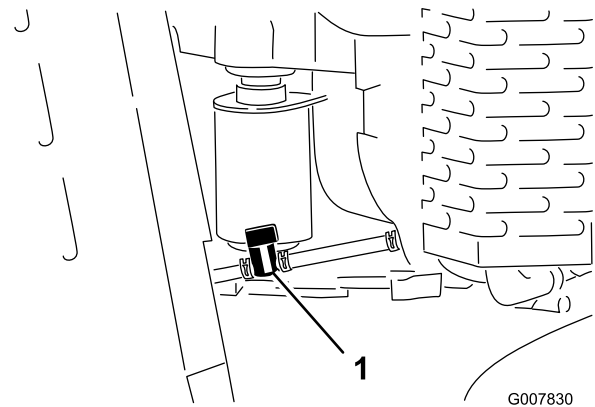

Figure 40

1. Fuel shutoff valve

5. Squeeze the ends of the hose clamp on the engine side of the shutoff valve together and slide it up the fuel line away from valve (Figure 40).
6. Pull the fuel line off the valve (Figure 40).
7. Open the fuel shutoff valve and allow the gasoline to drain into a gas can or drain pan.

Note: Now is the best time to install a new fuel filter because the fuel tank is empty. Refer to Replacing the Fuel Filter (page 30).

8. Install the fuel line onto the fuel shutoff valve. Slide the hose clamp close to the valve to secure the fuel line.

- Wipe up any spilled fuel.

Replacing the Fuel Filter

Service Interval: Every 200 hours

Never install a dirty filter if it is removed from the fuel line.

Note: Note how the fuel filter is installed in order to install the new filter correctly.

Note: Wipe up any spilled fuel.

- Lower the boom and set the parking brake.
- Stop the engine, remove the key, and wait for all moving parts to stop before leaving the operating position.
- Turn the fuel shutoff valve to the closed position (Figure 40).
- Squeeze the ends of the hose clamps together and slide them away from the filter (Figure 41).

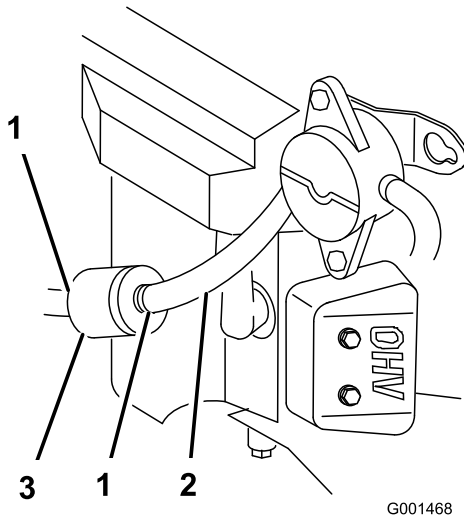

Figure 41

- | | |
|---------------|-----------|
| 1. Hose clamp | 3. Filter |
| 2. Fuel line | |

- Remove the filter from the fuel lines.
- Install a new filter and move the hose clamps close to the filter.
- Turn the fuel shutoff valve to the open position (Figure 40).
- Check for fuel leaks and repair if needed.
- Wipe up any spilled fuel.

Electrical System Maintenance

Servicing the Battery (Models 22973 and 22974)

Service Interval: Every 25 hours—Check the battery electrolyte level.

Always keep the battery clean and fully charged. Use a paper towel to clean the battery case. If the battery terminals are corroded, clean them with a solution of 4 parts water and 1 part baking soda. Apply a light coating of grease to the battery terminals to prevent corrosion.

Voltage: 12 V with 280 cold cranking Amps at -18° C (0° F).

⚠ WARNING

CALIFORNIA Proposition 65 Warning

Battery posts, terminals, and related accessories contain lead and lead compounds, chemicals known to the State of California to cause cancer and reproductive harm.
Wash hands after handling.

⚠ DANGER

Battery electrolyte contains sulfuric acid which is a deadly poison and causes severe burns.

Do not drink electrolyte and avoid contact with skin, eyes or clothing. Wear safety glasses to shield your eyes and rubber gloves to protect your hands.

Removing the Battery

⚠ WARNING

Battery terminals or metal tools could short against metal machine components causing sparks. Sparks can cause the battery gasses to explode, resulting in personal injury.

- When removing or installing the battery, do not allow the battery terminals to touch any metal parts of the machine.
- Do not allow metal tools to short between the battery terminals and metal parts of the machine.

⚠ WARNING

Incorrect battery cable routing could damage the machine and cables causing sparks. Sparks can cause the battery gasses to explode, resulting in personal injury.

- Always Disconnect the negative (black) battery cable before disconnecting the positive (red) cable.
- Always Reconnect the positive (red) battery cable before reconnecting the negative (black) cable.

1. Lower the boom and set the parking brake.
2. Stop the engine, remove the key, and wait for all moving parts to stop before leaving the operating position.
3. Lift the black rubber cover on the negative cable. Disconnect the negative battery cable from the negative (-) battery terminal (Figure 42).

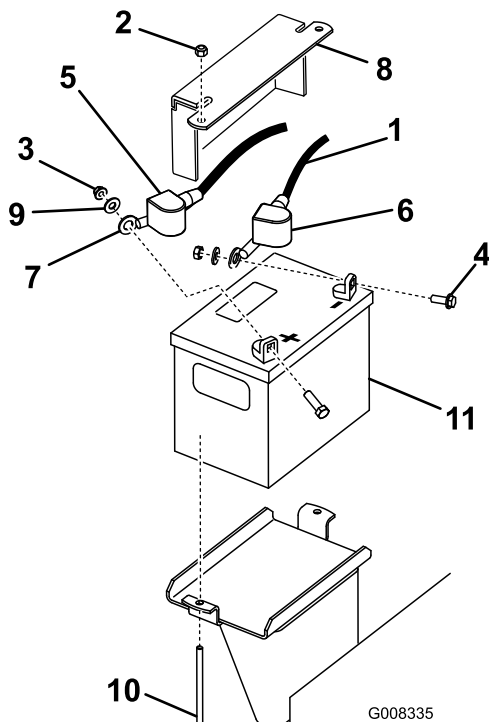

Figure 42

- | | |
|-------------------------|----------------------------|
| 1. Negative cable | 7. Positive cable |
| 2. Nut (1/4 inch) | 8. Battery hold down plate |
| 3. Nut (5/16 inch) | 9. Washer |
| 4. Bolt | 10. J-bolt |
| 5. Rubber cover (red) | 11. Battery |
| 6. Rubber cover (black) | |

4. Slide the red terminal boot off the positive (red) battery terminal. Then remove the positive (red) battery cable (Figure 42).

5. Remove the hold down plate, j-bolts, and locknuts securing the battery (Figure 42) and remove the battery.

Installing the Battery

1. Place the battery onto the machine (Figure 42).
2. Secure the battery with the hold down plate, j-bolts, and locknuts.
3. First, install the positive (red) battery cable to positive (+) battery terminal with a nut, washer and bolt (Figure 42). Slide the rubber cover over the post.
4. Then install the negative battery cable and ground wire to the negative (-) battery terminal with a nut, washer and bolt (Figure 42). Slide the rubber cover over the post.

Checking the Battery Electrolyte Level

⚠ DANGER

Battery electrolyte contains sulfuric acid which is a deadly poison and causes severe burns.

- Do not drink electrolyte and avoid contact with skin, eyes or clothing. Wear safety glasses to shield your eyes and rubber gloves to protect your hands.
- Fill the battery where clean water is always available for flushing the skin.

1. Look at the side of the battery. The electrolyte must be up to the **upper** line (Figure 43). Do not allow the electrolyte to fall below the Lower line (Figure 43).

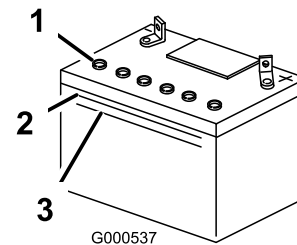

Figure 43

- | | |
|---------------|---------------|
| 1. Vent caps | 3. Lower line |
| 2. Upper line | |

2. If the electrolyte is low, add the required amount of distilled water; refer to Adding Water to the Battery (page 31).

Adding Water to the Battery

The best time to add distilled water to the battery is just before you operate the machine. This lets the water mix thoroughly with the electrolyte solution.

1. Remove the battery from the machine; refer to Removing the Battery (page 30).

Important: Never fill the battery with distilled water while the battery is installed in the machine. Electrolyte could be spilled on other parts and cause corrosion.

2. Clean the top of the battery with a paper towel.
3. Remove the vent caps from the battery (Figure 43).
4. Slowly pour distilled water into each battery cell until the electrolyte level is up to the upper line (Figure 43) on the battery case.

Important: Do not overfill the battery because electrolyte (sulfuric acid) can cause severe corrosion and damage to the chassis.

5. Wait 5 to 10 minutes after filling the battery cells. Add distilled water, if necessary, until the electrolyte level is up to the upper line (Figure 43) on the battery case.
6. Install the battery vent caps.

Charging the Battery

⚠ WARNING

Charging the battery produces gasses that can explode.

Never smoke near the battery and keep sparks and flames away from battery.

Important: Always keep the battery fully charged (1.265 specific gravity). This is especially important to prevent battery damage when the temperature is below 0° C (32° F).

1. Remove the battery from the chassis; refer to Removing the Battery (page 30).
2. Check the electrolyte level; refer to Checking the Battery Electrolyte Level (page 31).
3. Make sure the filler caps are installed in the battery.
4. Connect a 3 to 4 amp battery charger to the battery posts and charge the battery at a rate of 3 to 4 amperes for 4 to 8 hours (12 volts). **Do not overcharge the battery.**
5. When the battery is fully charged, unplug the charger from the electrical outlet, then disconnect the charger leads from the battery posts (Figure 44).
6. Install the battery onto the machine and connect the battery cables, refer to Installing the Battery (page 31).

Note: Do not run the machine with the battery disconnected, electrical damage may occur.

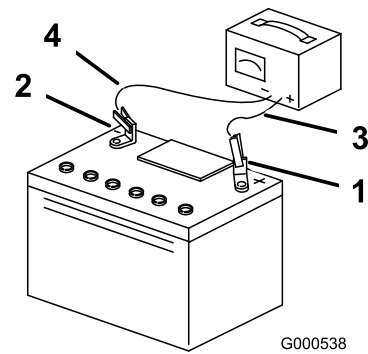

Figure 44

1. Positive Battery Post
2. Negative Battery Post
3. Red (+) Charger Lead
4. Black (-) Charger Lead

Replacing the Fuses (Models 22973 and 22974)

There are 4 fuses in the electrical system. They are under the control panel on the left side (Figure 45).

Start Circuit	30 amp
Charge Circuit	25 amp
Cooler fan Circuit	15 amp
Headlight (optional)	15 amp

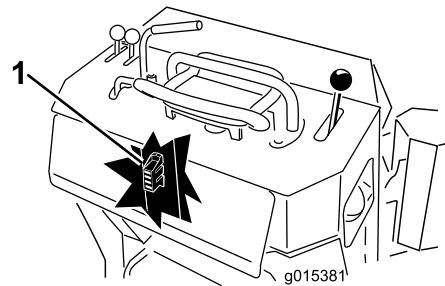

Figure 45

1. Fuse block

Drive System Maintenance

Servicing the Tracks

Cleaning the Tracks

Service Interval: Before each use or daily

Check the tracks for excessive wear and clean them periodically. If the tracks are worn, replace them.

1. Lower the boom and set the parking brake.
2. Stop the engine, remove the key, and wait for all moving parts to stop before leaving the operating position.
3. Using a water hose or pressure washer, remove dirt from each track system.

Important: Ensure that you use high-pressure water to wash only the track area. Do not use a high-pressure washer to clean the rest of the machine. High-pressure washing can damage the electrical system and hydraulic valves or deplete grease.

Important: Ensure that you fully clean the road wheels and the drive sprocket (Figure 46).

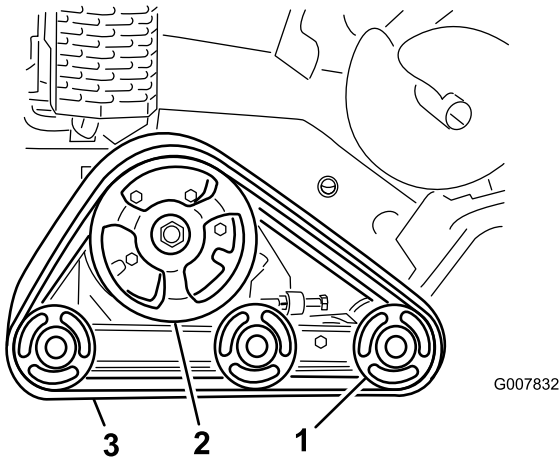

Figure 46

1. Road wheels
2. Drive sprocket
3. Track

Checking and Adjusting the Track Tension

Service Interval: After the first 50 hours

Every 100 hours

To check the tension of each track, place 20.4 kg (45 lb) on the track midway between the front road wheel and the drive sprocket. The track should flex no more than 0.6 to 1 cm (1/4 to 3/8 inch). If it does, adjust the track tension using the following procedure:

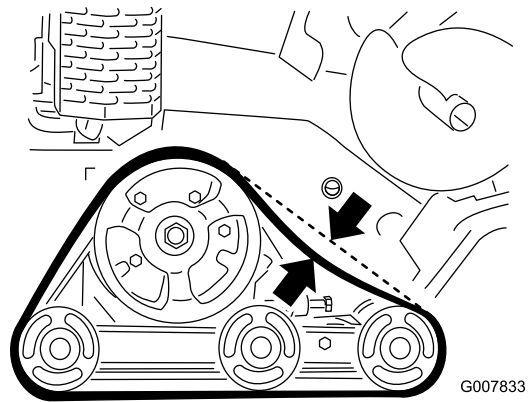

Figure 47

1. Stop the machine in on a level surface and set the parking brake.
2. Stop the engine, lower the boom, remove the key, and wait for all moving parts to stop before leaving the operating position.
3. Loosen the jam nut on the track tensioning bolt and the clamp bolts on the tension arm (Figure 48).

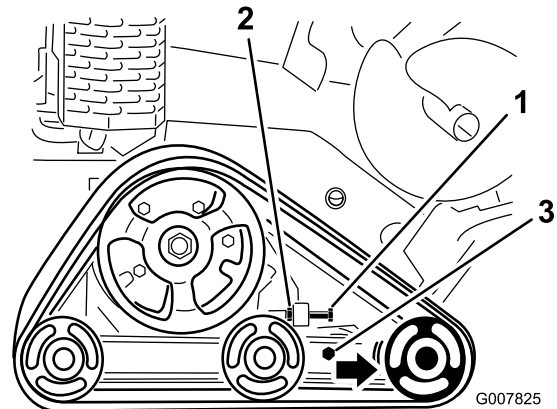

Figure 48

1. Tensioning bolt
2. Jam nut
3. Clamp bolts

4. Torque the tensioning bolt to 32.5 to 40 N-m (24 to 30 ft-lb) to tighten the track (Figure 48).
5. Ensure that the track deflects less than 0.6 to 1 cm (1/4 to 3/8 inch) when 20.6 kg (45 lb) of force is applied to the track span. Adjust the torque on the tensioning bolt as needed.
6. Tighten the jam nut.
7. Tighten the clamp bolts and torque to 102 N-m (75 ft-lb).

Replacing the Tracks

When the tracks are badly worn, replace them.

1. Lower the boom and set the parking brake.
2. Stop the engine, remove the key, and wait for all moving parts to stop before leaving the operating position.

3. Lift/support the side of the unit to be worked on so that the track is 7.6 to 10 cm (3 to 4 inches) off of the ground.
4. Back out the tensioning bolt and jam nut (Figure 48).
5. Loosen the clamp bolts (Figure 48).
6. Push the front road wheel rearward as far as it will go (Figure 49).

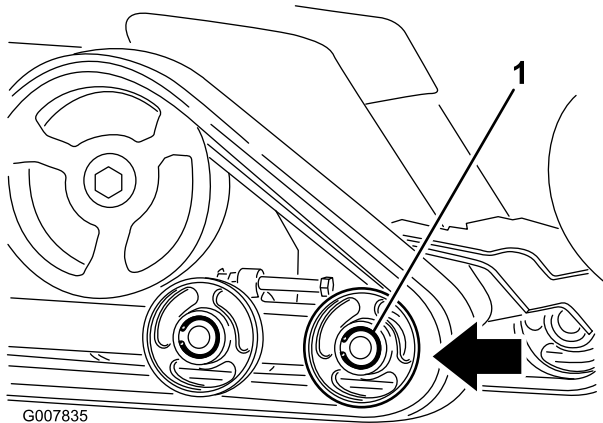

Figure 49

7. Begin removing the track at the top of the front road wheel, peeling it off of the wheel while rotating the track forwards.

Note: You may need to remove the front, outside road wheel. To remove this wheel, remove the snap ring and cap from the center of the road wheel (Figure 50). Next remove the bolt and gasket from the center of the wheel and pull the wheel off of the machine.

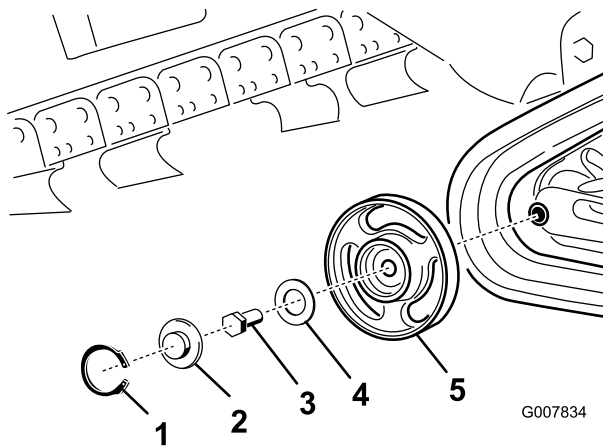

Figure 50

- | | |
|--------------|------------------------|
| 1. Snap ring | 4. Gasket |
| 2. Cap | 5. Wheel with bearings |
| 3. Bolt | |

8. When the track is off of the road wheel, remove it from the machine (Figure 49).

9. Beginning at the drive sprocket, coil the new track around the sprocket, ensuring that the lugs on the track fit between the spacers on the sprocket (Figure 49).
10. Push the track under and between the rear and center road wheels (Figure 49).
11. Starting at the bottom of the front road wheel, install the track around the wheel by rotating the track rearward while pushing the lugs into the wheel.
12. If you removed the front, outside road wheel, install it at this time using the bolt and gasket removed previously. Torque the bolt to 102 N-m (75 ft-lb) and then clean, grease, and install the cap and snap ring as instruction in the Checking and Greasing the Road Wheels (page 34) section.
13. Install the tensioning bolt and jam nut.
14. Torque the tensioning bolt to 32.5 to 40 N-m (24 to 30 ft-lb) to tighten the track.
15. Ensure that the track deflects less than 0.6 to 1 cm (1/4 to 3/8 inch) when 20.6 kg (45 lb) of force is applied to the track span. Adjust the torque on the tensioning bolt as needed.
16. Tighten the jam nut.
17. Tighten the clamp bolts and torque to 102 N-m (75 ft-lb).
18. Lower the machine to the ground.
19. Repeat steps 3 through 18 to replace the other track.

Checking and Greasing the Road Wheels

Service Interval: Every 250 hours

1. Remove the tracks; refer to Replacing the Tracks (page 33).
2. Remove the snap ring and cap from a road wheel (Figure 51).

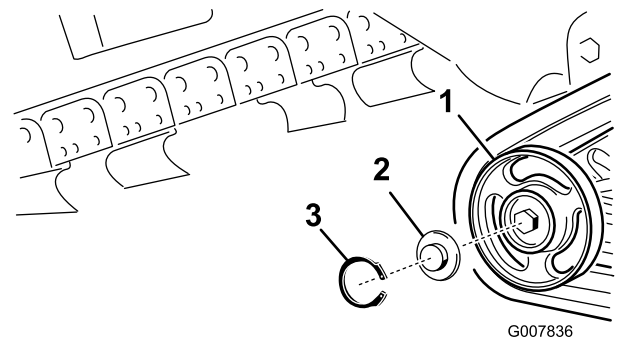

Figure 51

- | | |
|-------------------|--------------|
| 1. Road wheel | 3. Snap ring |
| 2. Road wheel cap | |

3. Check the grease under the cap and around the gasket (Figure 51). If it is dirty, gritty, or depleted, clean out all of the grease, replace the gasket, and add new grease.

4. Ensure that the road wheel turns smoothly on the bearing. If it is frozen, contact your Authorized Service Dealer to replace the road wheel.
5. Place the greased road wheel cap over the bolt head (Figure 51).
6. Secure the road wheel cap with the snap ring (Figure 51).
7. Repeat steps 2 through 6 for all 12 road wheels.
8. Install the tracks; refer to Replacing the Tracks (page 33).

Belt Maintenance

Replacing the Pump Drive Belt

If the pump drive belt begins to squeal or is cracked, worn, or frayed, replace it. Contact you Authorized Service Dealer for a replacement belt.

1. Raise the boom and set the parking brake.
2. Stop the engine, remove the key, and wait for all moving parts to stop before leaving the operating position.
3. Raise the back of the machine and support it on jack stands.
4. Remove the bottom shield; refer to Removing the Bottom Shield (page 23).
5. Loosen the 2 pump bolts (Figure 52).

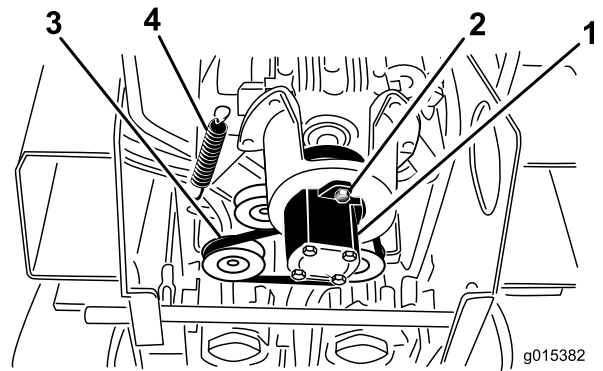

Figure 52

- | | |
|---------------|------------------------|
| 1. Pump | 3. Belt |
| 2. Pump bolts | 4. Idler pulley spring |

6. Twist the pump counter clockwise and allow it to drop down away from the pulley (Figure 52).

Note: Ensure that the spider coupler drops down with the pump.

7. Using a spring puller (contact your Authorized Service Dealer) or stiff metal hook, pull the end of the idler pulley spring off the spring bolt to release tension on the belt (Figure 52).
8. Remove the belt.
9. Route a new belt around the pulleys.
10. Install the idler pulley spring on the bolt.
11. Ensure that the spider coupler is in place on the pump and then insert it into the pulley, twisting it clockwise to seat it on the pump bolts.
12. Torque the pump bolts to 68 N-m (50 ft-lb).
13. Install the bottom shield.

Controls System Maintenance

The factory adjusts the controls before shipping the machine. However, after many hours of use, you may need to adjust the traction control alignment, the Neutral position of the traction control, and the tracking of the traction control in the full forward position.

Important: To adjust the controls properly, complete each procedure in the order listed.

Adjusting the Traction Control Alignment

If the traction control bar does not rest flush and square with the reference bar when in the full backward position, immediately complete the following procedure:

1. Park the machine on a flat surface and lower the boom.
2. Stop the engine and remove the key.
3. Pull straight back on the traction control so the front of the control contacts the reference bar (Figure 53).

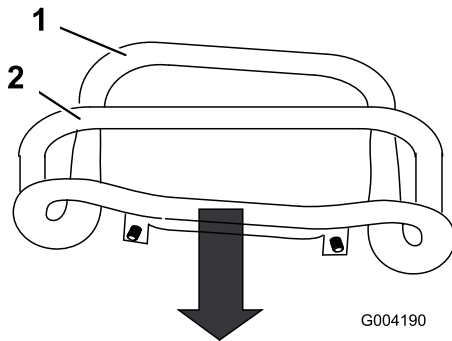

Figure 53

1. Front of the control, out of alignment
2. Reference bar

4. If the front of the traction control does not rest square and flush with the reference bar, loosen the flange nut and bolt in the stem of the traction control (Figure 54).

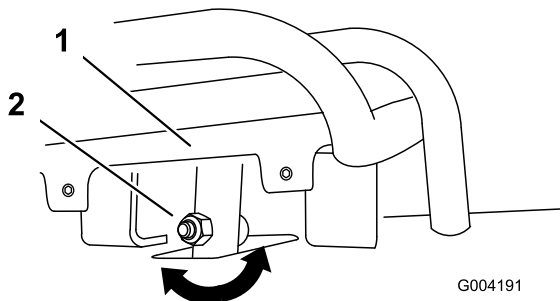

Figure 54

1. Traction control
2. Stem, bolt and nut

5. Adjust the traction control so that it rests flush against the reference bar when it is pulled straight back (Figure 54 and Figure 55).

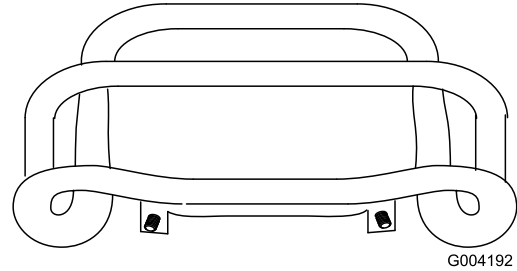

Figure 55

6. Tighten the flange nut and bolt in the traction control stem.
7. Start the engine.
8. Drive the machine in reverse with the traction control tight to the reference bar. If the machine does not back up straight, complete the following procedure:
 - A. Stop the engine
 - B. Lift/support the machine so that both tracks are off of the ground and are free to run.
 - C. Loosen the flange nut and bolt in the stem of the traction control (Figure 54).
 - D. Loosen the jam nuts on the traction rods, under the control panel (Figure 56).

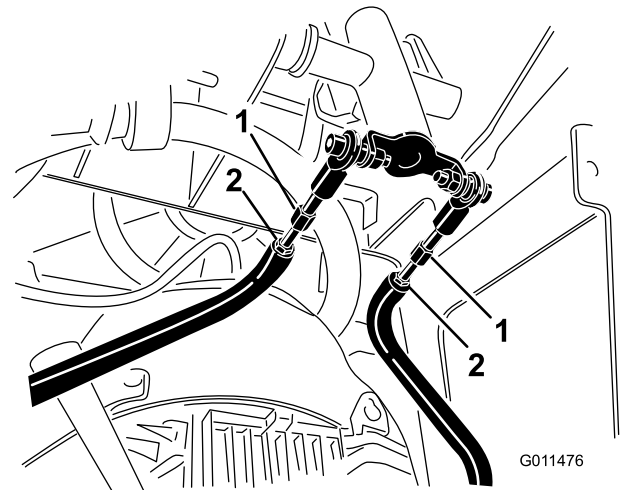

Figure 56

1. Traction rod
2. Jam nut

- E. Start the machine and set the throttle to about 1/3 open position.

▲ WARNING

When the machine is running, you could be caught and injured in moving parts or burned on hot surfaces.

Stay away from pinch points, moving parts, and hot surfaces when adjusting the running machine.

- F. Have a helper hold the traction control tight to the reference bar in reverse.
- G. Adjust the length of the traction rods until both tracks are running at the same speed.
Note: You can also adjust the maximum reverse speed of the tracks at this time.
- H. Tighten the jam nuts.
- I. Adjust the traction control so that it rests flush against the reference bar when it is pulled straight back (Figure 54 and Figure 55).
- J. Tighten the flange nut and bolt in the traction control stem.
- K. Stop the engine and lower the machine to the ground.
- L. Drive the machine in full reverse, checking to see if the unit tracks straight. If it does not, note the direction the machine veers. Repeat the adjustment previously described so that it tracks straight in reverse.

- 4. If the machine veers to the **right**, loosen the **left** jam nut and adjust the tracking set screw on the front of the traction control (Figure 57).

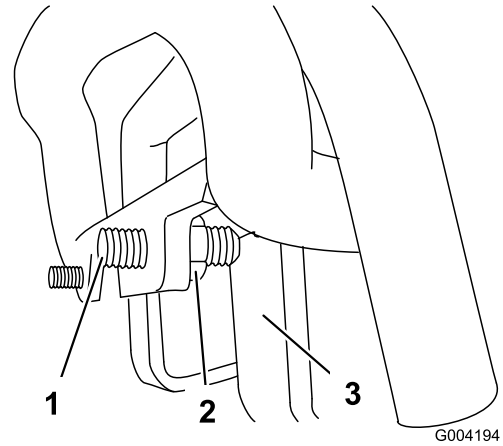

Figure 57

- 1. Set screw
- 2. Jam nut
- 3. Stop

- 5. Repeat steps 1 through 4 until the machine drives straight in the full forward position.

Important: Ensure the tracking set screws touch the stops in the full forward position to avoid over stroking the hydraulic pumps.

Adjusting the Traction Control Neutral Position

If the machine creeps forward or backward when the traction control is in neutral and the unit is warm, the return-to-neutral mechanism on the pumps may need to be adjusted; contact your Authorized Service Dealer for repairs.

Adjusting the Tracking of the Traction Control, Full Forward Position

If the machine does not drive straight when you hold the traction control forward against the reference bar, complete the following procedure:

- 1. Drive the machine with the traction control against the reference bar, noting which direction the machine veers.
- 2. Release the traction control.
- 3. If the machine veers to the **left**, loosen the **right** jam nut and adjust the tracking set screw on the front of the traction control (Figure 57).

Hydraulic System Maintenance

Replacing the Hydraulic Filter

Service Interval: Every 200 hours

1. Position machine on a level surface.
2. Lower the boom and set the parking brake.
3. Stop the engine, remove the key, and wait for all moving parts to stop before leaving the operating position.
4. Remove the top cover.
5. Remove and discard the old filter (Figure 58).

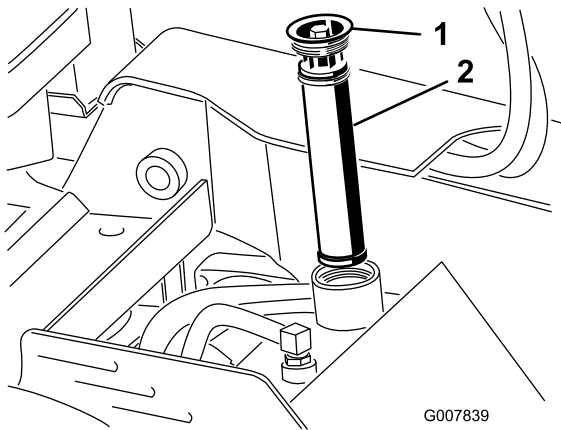

Figure 58

1. Filler cap
2. Hydraulic filter

6. Install the replacement hydraulic filter and filler cap (Figure 58) and torque bolt on top to 13 to 15.5 N-m (110 to 140 in-lb).
7. Clean up any spilled fluid.
8. Install the top cover.

Changing the Hydraulic Fluid

Service Interval: Every 400 hours/Yearly (whichever comes first)

Hydraulic Fluid Specification:

Use only one of the following fluids in the hydraulic system:

- **Toro Premium Transmission/Hydraulic Tractor Fluid** (refer to your Authorized Toro Dealer for more information)
- **Toro Premium All Season Hydraulic Fluid** (refer to your Authorized Toro Dealer for more information)
- If either of the above Toro fluids are not available, you may use another **Universal Tractor Hydraulic**

Fluid (UTHF), but they must be only **conventional, petroleum-based** products. The specifications must fall within the listed range for all of the following material properties and the fluid should meet the listed industry standards. Check with your oil supplier to determine if the oil meets these specifications.

Note: Toro will not assume responsibility for damage caused by improper substitutions, so use only products from reputable manufacturers who will stand behind their recommendations.

Material Properties	
Viscosity, ASTM D445	cSt at 40° C: 55 to 62
	cSt at 100° C: 9.1 to 9.8
Viscosity index, ASTM D2270	140 to 152
Pour Point, ASTM D97	-37° to -43° C (-35° to -46° F)
Industry Standards	
API GL-4, AGCO Powerfluid 821 XL, Ford New Holland FNHA-2-C-201.00, Kubota UDT, John Deere J20C, Vickers 35VQ25 and Volvo WB-101/BM.	

Note: Many hydraulic fluids are almost colorless, making it difficult to spot leaks. A red dye additive for the hydraulic system oil is available in 20 ml (2/3 oz) bottles. One bottle is sufficient for 15-22 L (4-6 gallons) of hydraulic oil. Order part no. 44-2500 from your Authorized Toro Dealer.

1. Position the machine on a level surface.
2. Lower the boom and set the parking brake.
3. Stop the engine, remove the key, and wait for all moving parts to stop before leaving the operating position.
4. Allow the machine to cool completely.
5. Remove the top cover.
6. Remove the hydraulic tank filler cap and filter (Figure 58).
7. Place a drain pan capable of hold 37.8 L (10 US Gallons) under the hydraulic tank.
8. Pinch the hose clamp and slide the clamp and hose off of the fitting on the hydraulic tank, allowing the hydraulic fluid to drain from the hose and tank into the pan.

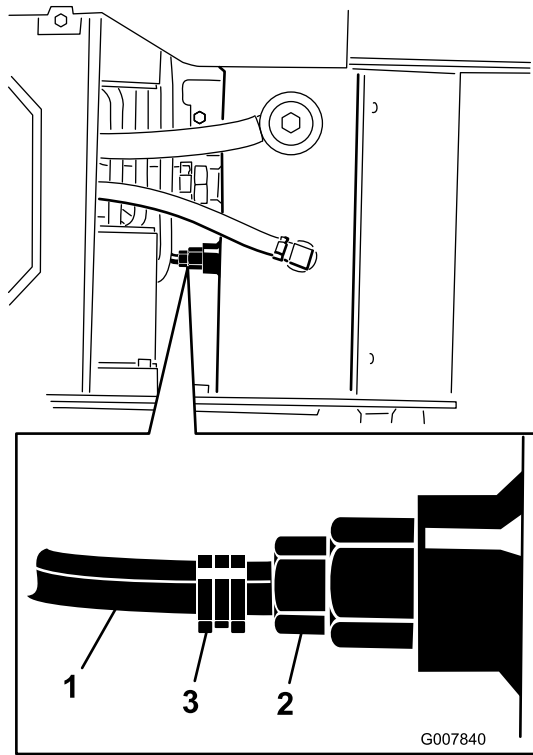

Figure 59

1. Hose
2. Hydraulic tank fitting
3. Hose clamp

9. When finished, install the hose onto the fitting and secure it with the hose clamp.

Note: Dispose of the used oil at a certified recycling center.

10. Fill the hydraulic tank with approximately 23 L (6 US gallons) of 10W-30 or 15W-40 detergent, diesel engine oil (API service CH-4 or higher); refer to Checking Hydraulic Fluid.
11. Add 236 ml (8 fl oz) of AMSOIL® Slip-Lock™ differential additive or an equivalent differential additive to the hydraulic tank.

Note: AMSOIL and Slip-Lock are trademarks of AMSOIL Inc.

12. Install the hydraulic filter and filler cap (Figure 58) and torque bolt on top to 13 to 15.5 N-m (110 to 140 in-lb).
13. Start the engine and let it run for a few minutes.
14. Stop the engine.
15. Check the hydraulic fluid level and top it off if necessary; refer to Checking the Hydraulic Fluid Level (page 17).
16. Clean up any spilled fluid.
17. Install the top cover.

Checking the Hydraulic Lines

Service Interval: Every 100 hours—Check the hydraulic lines for leaks, loose fittings, kinked lines, loose mounting supports, wear, weather, and chemical deterioration and repair if necessary.

Every 1,500 hours/Every 2 years (whichever comes first)—Replace all moving hydraulic hoses.

⚠ WARNING

Hydraulic fluid escaping under pressure can penetrate skin and cause injury. Fluid injected into the skin must be surgically removed within a few hours by a doctor familiar with this form of injury or gangrene may result.

- Keep your body and hands away from pin hole leaks or nozzles that eject high pressure hydraulic fluid.
- Use cardboard or paper to find hydraulic leaks, never use your hands.

Trencher Maintenance

Replacing the Digging Teeth

Service Interval: Before each use or daily—Check the condition of the digging teeth and replace any that are worn or damaged.

Due to the high amount of wear placed on the digging teeth, you will need to replace them periodically.

To replace a single tooth, remove the bolts securing the tooth to remove it, then install a new tooth in the same position. Torque the bolts securing the teeth to 37 to 45 N-m (27 to 33 ft-lb).

Checking and Adjusting the Digging Chain and Boom

Service Interval: Every 25 hours

- Check each link in the chain for excessive wear, such as links that will no longer hold teeth.
- Inspect the bottom of the boom for wear
- With the trencher parallel to the ground, ensure that there are 3.8 to 6.3 cm (1-1/2 to 2-1/2 inches) between the bottom of the boom and the top of the bottom chain span. If not adjust the chain tension.

Important: Do not over tighten the chain. Excess chain tension may damage drive components.

To replace a worn chain, flip or replace a worn boom, or to adjust the chain tension, use the following procedure:

1. To replace the chain or to flip or replace the boom, complete the following:
 - A. Remove the 2 bolts and nuts securing the boom to the trencher arm

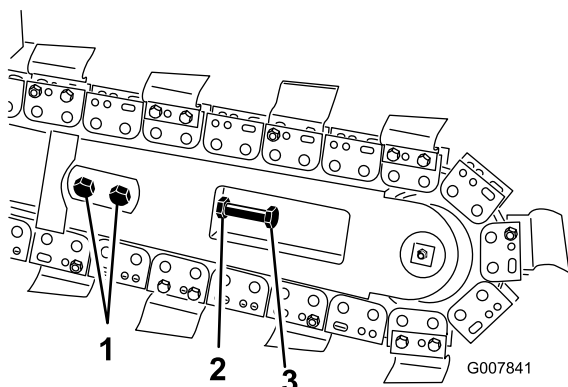

Figure 60

1. Bolts
2. Jam nut
3. Adjusting bolt

- B. Loosen the jam nut on the adjusting bolt in the boom.
- C. Loosen the adjusting bolt until you can remove the chain from the boom
- D. Remove the chain from the drive sprocket.
- E. If the chain needs replacing, remove the bolt and nut securing the spoils auger and remove the auger and chain.
- F. Remove the boom, flip it over so the bottom becomes the top (or if you have already flipped it once, replace it), and install the boom again.
- G. Replace the nuts, bolts, and washers securing the boom.
- H. If installing a new chain, connect the links by pressing or hammering the clevis pin supplied with the chain through the links, then secure the clevis pin with the cotter pin supplied with the chain.

Important: To avoid bending the chain links, place blocks under and between the links when hammering the clevis pin through.

- I. Install the chain over the drive sprocket and front roller.
 - J. If you removed the spoils auger, install it using the bolt and nut you removed previously. Torque the bolt and nut to 102 N-m (75 ft-lb).
 - K. Skip to step 4 to complete the adjustment.
2. Loosen the 2 bolts and nuts securing the boom to the trencher arm
 3. Loosen the jam nut securing the adjustment bolt.
 4. Turn the adjustment bolt in or out as needed to achieve the desired tension.
 5. Tighten the jam nut.
 6. Torque the 2 bolts and nuts securing the boom to 183 to 223 N-m (135 to 165 ft-lb).

Replacing the Drive Sprocket

Over time, the drive sprocket will wear, especially when used in sandy or clay soils. When this happens, the digging chain will begin to slip. If the chain slips, replace the drive sprocket, as follows:

1. Raise the trencher a few inches above the ground.
2. Stop the engine and remove the key.
3. Remove the spoils auger (Figure 61).

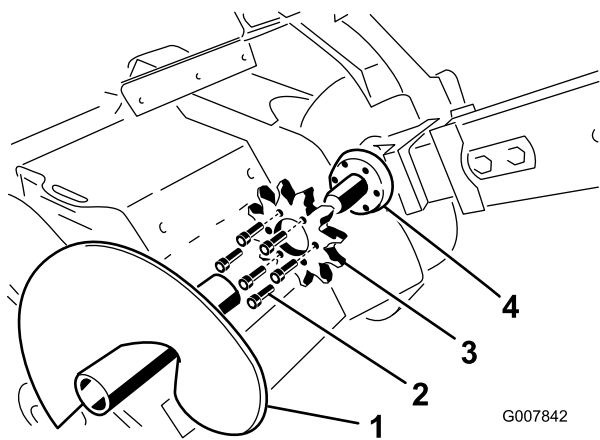

Figure 61

1. Spoils auger
2. Bolts
3. Drive sprocket
4. Sprocket mounting surface

17. Thread the jam nut down the adjusting bolt and tighten it securely against the boom.
18. Torque the 2 bolts and nuts securing the boom to 183 to 223 N-m (135 to 165 ft-lb).
19. Install the spoils auger using the bolt and nut you removed previously.

Note: Torque the bolt and nut to 102 N-m (75 ft-lb).

4. Loosen the 2 bolts and nuts securing the boom to the trencher arm.
5. Loosen the jam nut on the adjusting bolt in the boom.
6. Loosen the adjusting bolt until you can remove the chain from the boom.
7. Remove the chain from the drive sprocket.
8. Remove the six bolts securing the drive sprocket (Figure 61).
9. Remove and discard the drive sprocket (Figure 61).
10. Clean the sprocket mounting surface on the trencher (Figure 61).
11. Slide the new sprocket onto the shaft (Figure 61).

Important: The arrow on the sprocket face should be visible from the right side of the trench and should point in a clockwise direction; if not, turn the sprocket around.

12. Thread the six bolts into the sprocket finger tight (Figure 61).
13. Slowly begin tightening the bolts progressing around the sprocket until all bolts are torqued to 129 to 155 N-m (95 to 115 ft-lb).

Important: Tighten each bolt only half way first, working your way around the six bolts, then return to each bolt in turn and torque them

14. Loop the chain over the auger drive shaft and onto the drive sprocket, ensuring that the teeth point forward on the upper span.
15. Set the upper span of the chain into place on the trencher boom, then wrap the chain around the roller at the end of the boom.
16. Thread the adjustment bolt into the boom and turn it in until there is 3.8 to 6.3 cm (1-1/2 to 2-1/2 inches) of slack in the chain on the bottom span.

Cleaning

Removing Debris from the Machine

Important: Operating the engine with blocked screens, dirty or plugged cooling fins, and/or cooling shrouds removed, will result in engine damage from overheating.

1. Lower the boom and set the parking brake.
2. Stop the engine, remove the key, and wait for all moving parts to stop before leaving the operating position.
3. Wipe away debris from the air cleaner.
4. Clean any debris build-up on the engine with a brush or blower.

Important: It is preferable to blow dirt out, rather than washing it out. If water is used, keep it away from electrical items and hydraulic valves. Do not use a high-pressure washer. High-pressure washing can damage the electrical system and hydraulic valves or deplete grease.

5. Clean debris from the oil cooler.

Storage

1. Lower the boom and set the parking brake.
2. Stop the engine, remove the key, and wait for all moving parts to stop before leaving the operating position.
3. Remove dirt and grime from the external parts of the entire machine, especially the engine. Clean dirt and chaff from the outside of the engine cylinder head fins and blower housing.

Important: You can wash the machine with mild detergent and water. Do not pressure wash the machine. Avoid excessive use of water, especially near the control panel, engine, hydraulic pumps, and motors.

4. Service the air cleaner; refer to Servicing the Air Cleaner (Models 22972 and 22973) (page 25) and Servicing the Air Cleaner (Model 22974) (page 26).
5. Grease the machine; refer to Greasing the Machine (page 24).
6. Change the crankcase oil; refer to Changing the Oil (page 27).
7. Remove the spark plug and check the condition of it; refer to Servicing the Spark Plug (page 28).
8. For storage over 30 days, prepare the machine as follows:
 - A. Add a petroleum based stabilizer/conditioner to fuel in the tank. Follow mixing instructions from stabilizer manufacturer. (1 oz. per US gallon). **Do not use an alcohol based stabilizer (ethanol or methanol).**
 - Note:** Fuel stabilizer/conditioner is most effective when mixed with fresh gasoline and used at all times.
 - B. Run the engine to distribute conditioned fuel through the fuel system (5 minutes).
 - C. Stop the engine, allow it to cool and drain the fuel tank using a pump type syphon.
 - D. Restart the engine and run it until it stops.
 - E. Choke the engine.
 - F. Start and run the engine until it will not start again.
 - G. Dispose of fuel properly. Recycle as per local codes.

Important: Do not store stabilizer/conditioned gasoline over 90 days.

9. With the spark plug removed from the engine, pour two tablespoons of engine oil into the spark plug hole.
10. Place a rag over the spark plug hole to catch any oil spray, then use the starter or recoil handle to crank the engine and distribute the oil inside the cylinder.
11. Install the spark plug, but do not install the wire on the spark plug.

12. Charge the battery (model 22973 and 22974); refer to Servicing the Battery (Models 22973 and 22974) (page 30).
13. Check and adjust the track tension; refer to Checking and Adjusting the Track Tension (page 33).
14. Check and adjust the digging chain tension; refer to Checking and Adjusting the Digging Chain and Boom (page 40).
15. Check and tighten all bolts, nuts, and screws. Repair or replace any part that is damaged.
16. Paint all scratched or bare metal surfaces. Paint is available from your Authorized Service Dealer.
17. Store the machine in a clean, dry garage or storage area. Remove the key from the ignition switch and keep it in a memorable place.
18. Cover the machine to protect it and keep it clean.

Troubleshooting

Problem	Possible Cause	Corrective Action
The starter does not crank (models 22973 and 22974).	<ol style="list-style-type: none"> 1. The battery is discharged. 2. The electrical connections are corroded or loose. 3. The relay or switch is damaged. 	<ol style="list-style-type: none"> 1. Charge the battery or replace it. 2. Check the electrical connections for good contact. 3. Contact your Authorized Service Dealer.
The engine will not start, starts hard, or fails to keep running.	<ol style="list-style-type: none"> 1. The fuel tank is empty. 2. The fuel shutoff valve is closed. 3. The controls are not in neutral. 4. The choke is not on. 5. The air cleaner is dirty. 6. The spark plug wire is loose or disconnected. 7. The spark plug is pitted, fouled, or the gap is incorrect. 8. Dirt, water, or stale fuel is in fuel system. 	<ol style="list-style-type: none"> 1. Fill the fuel tank with gasoline. 2. Open the fuel shutoff valve. 3. Move the controls to neutral. 4. Move the choke lever fully forward. 5. Clean or replace the air cleaner elements. 6. Install the wire on the spark plug. 7. Install a new, correctly gapped spark plug. 8. Contact your Authorized Service Dealer.
Engine loses power.	<ol style="list-style-type: none"> 1. The engine load is excessive. 2. The air cleaner is dirty. 3. The oil level in crankcase is low. 4. The cooling fins and air passages under the engine blower housing are plugged. 5. The spark plug is pitted, fouled, or the gap is incorrect. 6. Dirt, water, or stale fuel is in fuel system. 	<ol style="list-style-type: none"> 1. Reduce ground speed. 2. Clean or replace the air cleaner elements. 3. Check and add oil to the crankcase. 4. Remove any obstructions from the cooling fins and air passages. 5. Install a new, correctly gapped spark plug. 6. Contact your Authorized Service Dealer.
The engine overheats.	<ol style="list-style-type: none"> 1. The engine load is excessive. 2. The oil level in crankcase is low. 3. The cooling fins and air passages under the engine blower housing are plugged. 	<ol style="list-style-type: none"> 1. Reduce ground speed. 2. Check and add oil to the crankcase. 3. Remove any obstructions from the cooling fins and air passages.
There is abnormal vibration.	<ol style="list-style-type: none"> 1. The engine mounting bolts are loose. 	<ol style="list-style-type: none"> 1. Tighten the engine mounting bolts.
The machine does not drive.	<ol style="list-style-type: none"> 1. The parking brake is on. 2. The hydraulic fluid level is low. 3. The tow valves are open. 4. The hydraulic system is damaged. 	<ol style="list-style-type: none"> 1. Release the parking brake. 2. Check and add hydraulic fluid. 3. Close the tow valves. 4. Contact your Authorized Service Dealer.
The chain does not turn.	<ol style="list-style-type: none"> 1. Sand or debris has built up in a tooth root of the drive sprocket. 2. The digging chain is too tight. 3. The trencher boom end bearing has failed. 4. The trencher drive system is damaged. 5. The hydraulic system is obstructed, contaminated, or damaged. 	<ol style="list-style-type: none"> 1. Run the chain backwards and then reduce the chain tension. 2. Adjust the digging chain tension. 3. Contact your Authorized Service Dealer. 4. Contact your Authorized Service Dealer. 5. Contact your Authorized Service Dealer.

Problem	Possible Cause	Corrective Action
The trencher does not dig fast enough.	<ol style="list-style-type: none"> 1. The digging teeth are worn. 2. The chain you are using is not appropriate for the type of ground. 3. The hydraulic system is overheated. 4. The hydraulic system is obstructed, contaminated, or damaged. 	<ol style="list-style-type: none"> 1. Replace the digging teeth. 2. Evaluate the ground type and change chains if necessary. 3. Shutdown and allow the system to cool. 4. Contact your Authorized Service Dealer.

Schematics

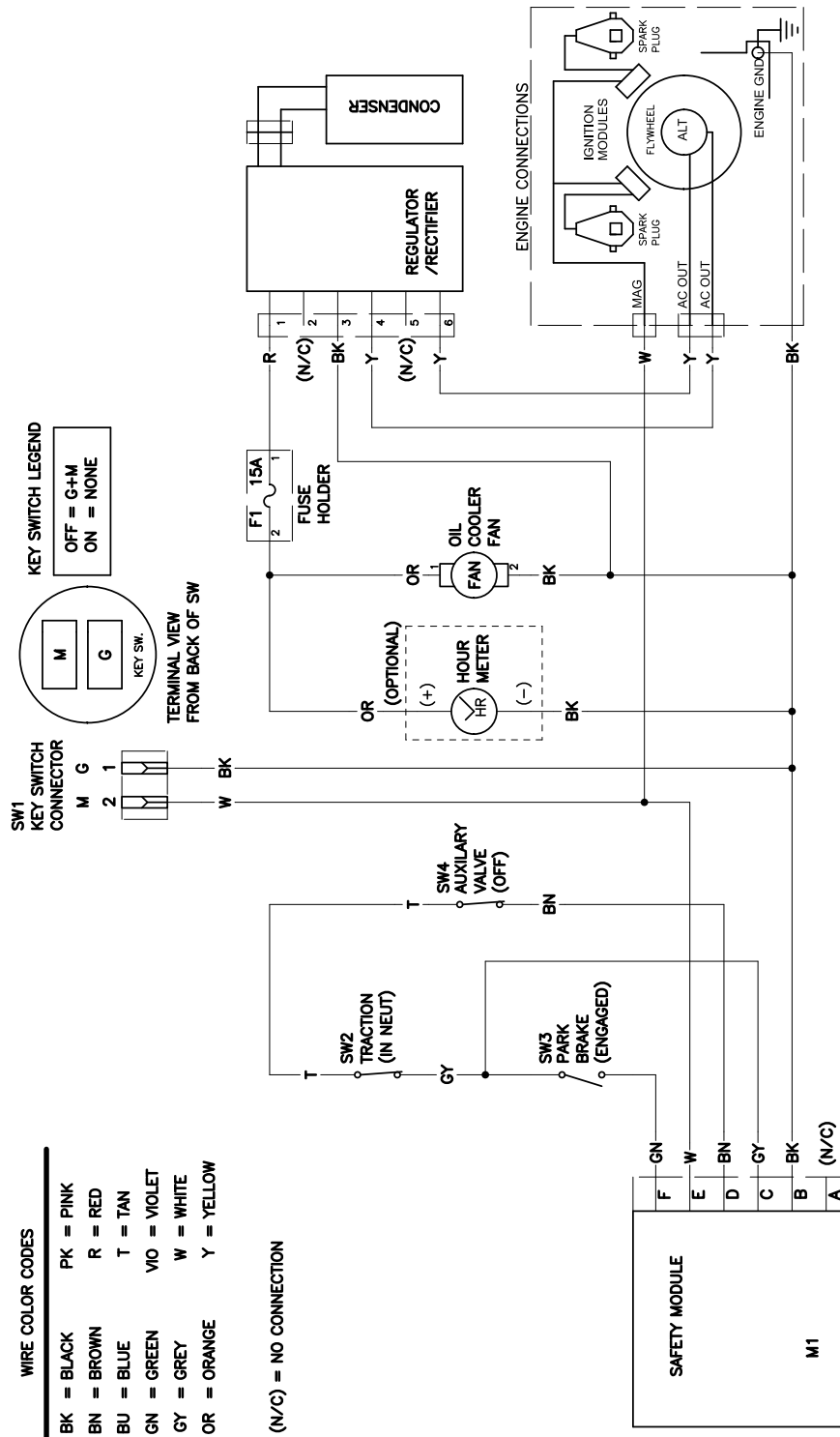

g015383

Electrical Schematic—Model 22972 (Rev. A)

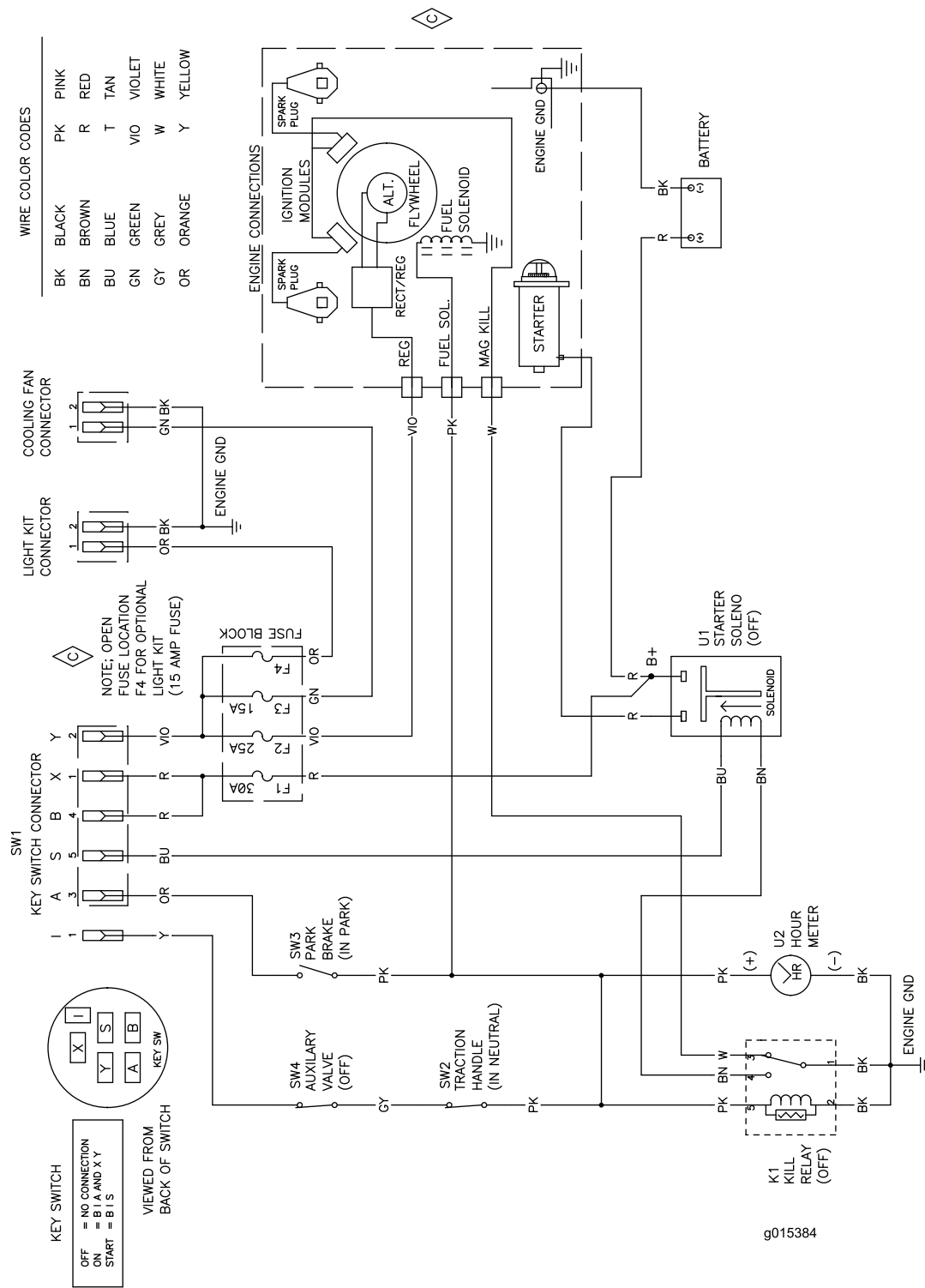

Electrical Schematic—Model 22973 (Rev. A)

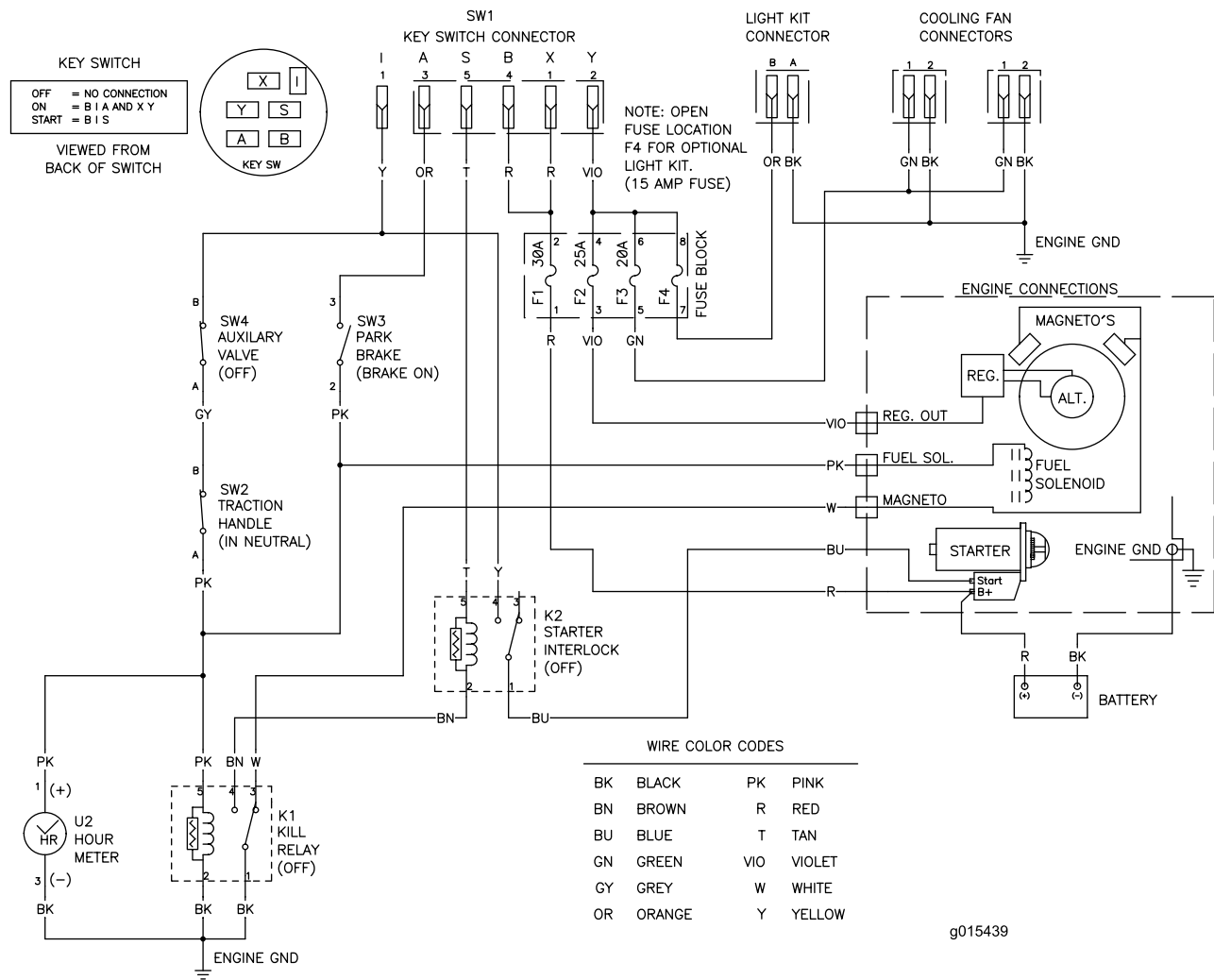

Electrical Schematic—Model 22974 (Rev. A)

LIFT

Ø 51/25 X 254

TRENCHER

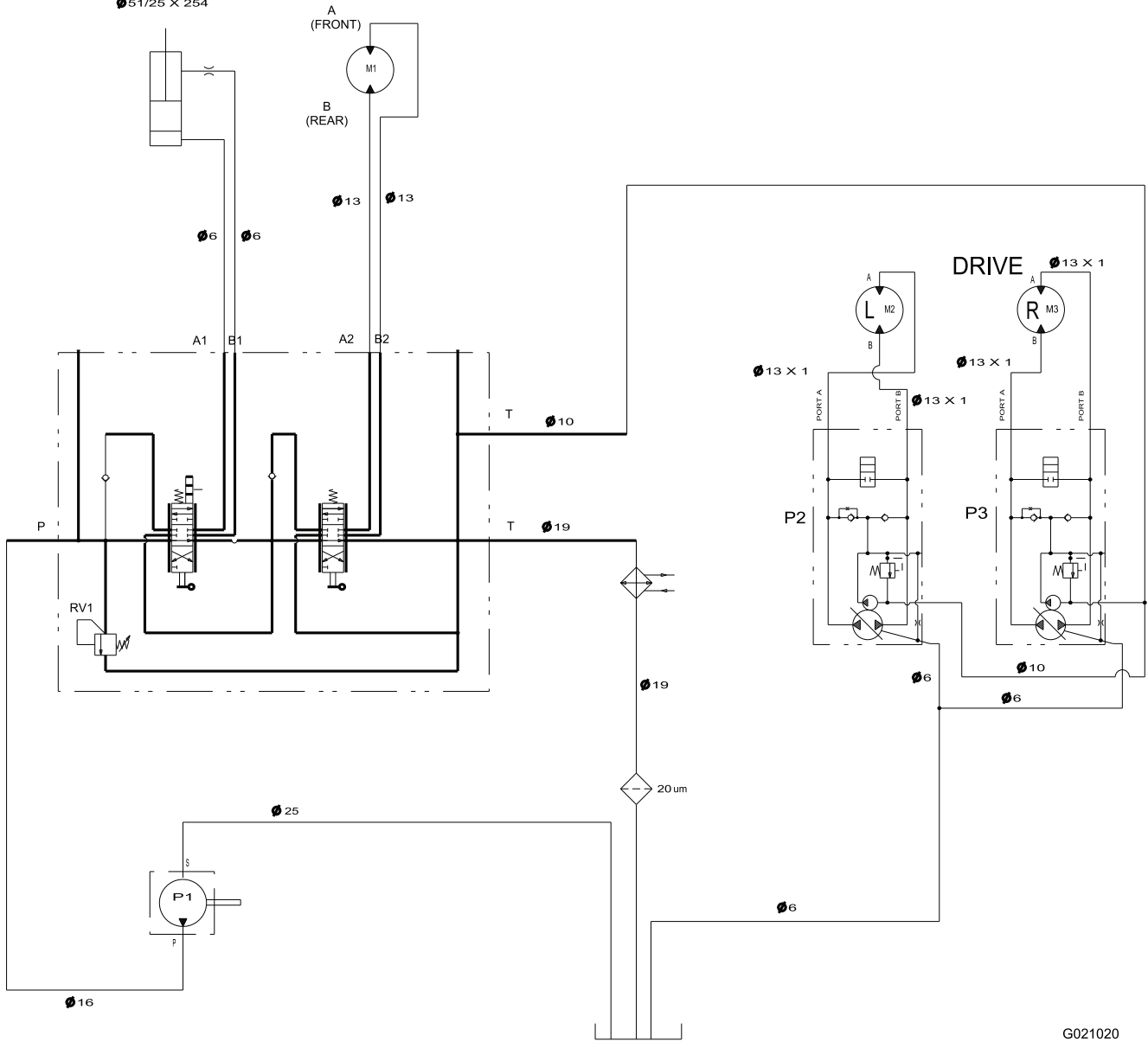

G021020

Hydraulic Schematic (Rev. B)

Notes:

Notes:



Toro Compact Utility Equipment Warranty

A One-Year Limited Warranty

Compact Utility Equipment
(CUE) Products

Conditions and Products Covered

The Toro Company and its affiliate, Toro Warranty Company, pursuant to an agreement between them, jointly warrant your Toro Compact Utility Equipment ("Product") to be free from defects in materials or workmanship. The following time periods apply from the date of purchase:

Products	Warranty Period
Pro Sneak Compact Utility Loaders, Trenchers, Stump Grinders, and Attachments	1 year or 1000 operating hours, whichever occurs first
Kohler Engines	3 years*
All other Engines	2 years*

Where a warrantable condition exists, we will repair the Product at no cost to you including diagnosis, labor, and parts.

*Some engines used on Toro Products are warranted by the engine manufacturer.

Instructions for Obtaining Warranty Service

If you think that your Toro Product contains a defect in materials or workmanship, follow this procedure:

1. Contact any Authorized Toro Compact Utility Equipment (CUE) Service Dealer to arrange service at their dealership. To locate a dealer convenient to you, access our website at www.Toro.com. You may also call our Toro Customer Care Department toll free at the number below.
2. Bring the product and your proof of purchase (sales receipt) to the Service Dealer.
3. If for any reason you are dissatisfied with the Service Dealer's analysis or with the assistance provided, contact us at:

SWS Customer Care Department
Toro Warranty Company
8111 Lyndale Avenue South
Bloomington, MN 55420-1196
Toll Free: 888-384-9940

Owner Responsibilities

You must maintain your Toro Product by following the maintenance procedures described in the *Operator's Manual*. Such routine maintenance, whether performed by a dealer or by you, is at your expense. Parts scheduled for replacement as required maintenance ("Maintenance Parts"), are warranted for the period of time up to the scheduled replacement time for that part. Failure to perform required maintenance and adjustments can be grounds for disallowing a warranty claim.

Items and Conditions Not Covered

Not all product failures or malfunctions that occur during the warranty period are defects in materials or workmanship. This express warranty does not cover the following:

- Product failures which result from the use of non-Toro replacement parts, or from installation and use of add-on, modified, or unapproved accessories
- Product failures which result from failure to perform required maintenance and/or adjustments
- Product failures which result from operating the Product in an abusive, negligent or reckless manner
- Parts subject to consumption through use unless found to be defective. Examples of parts which are consumed, or used up, during normal product operation include, but are not limited to, belts, wipers, spark plugs, tires, filters, gaskets, wear plates, seals, O-rings, drive chains, clutches.
- Failures caused by outside influence. Items considered to be outside influence include, but are not limited to, weather, storage practices, contamination, use of unapproved coolants, lubricants, additives, or chemicals, etc.
- Normal "wear and tear" items. Normal "wear and tear" includes, but is not limited to, worn painted surfaces, scratched decals, etc.
- Repairs necessary due to failure to follow recommended fuel procedure (consult *Operator's Manual* for more details)
 - Removing contaminants from the fuel system is not covered
 - Use of old fuel (more than one month old) or fuel which contains more than 10% ethanol or more than 15% MTBE
 - Failure to drain the fuel system prior to any period of non-use over one month
- Any component covered by a separate manufacturer's warranty
- Pickup and delivery charges

General Conditions

Repair by an Authorized Toro Compact Utility Equipment (CUE) Service Dealer is your sole remedy under this warranty.

Neither The Toro Company nor Toro Warranty Company is liable for indirect, incidental or consequential damages in connection with the use of the Toro Products covered by this warranty, including any cost or expense of providing substitute equipment or service during reasonable periods of malfunction or non-use pending completion of repairs under this warranty. All implied warranties of merchantability and fitness for use are limited to the duration of this express warranty. Some states do not allow exclusions of incidental or consequential damages, or limitations on how long an implied warranty lasts, so the above exclusions and limitations may not apply to you.

This warranty gives you specific legal rights, and you may also have other rights which vary from state to state.

Except for the engine warranty coverage and the Emissions warranty referenced below, if applicable, there is no other express warranty. The Emissions Control System on your Product may be covered by a separate warranty meeting requirements established by the U.S. Environmental Protection Agency (EPA) or the California Air Resources Board (CARB). The hour limitations set forth above do not apply to the Emissions Control System Warranty. Refer to the California Emission Control Warranty Statement supplied with your Product or contained in the engine manufacturer's documentation for details.

Countries Other than the United States or Canada

Customers who have purchased Toro products outside the United States or Canada should contact their Toro Distributor (Dealer) to obtain guarantee policies for your country, province, or state. If for any reason you are dissatisfied with your Distributor's service or have difficulty obtaining guarantee information, contact the Toro importer. If all other remedies fail, you may contact us at Toro Warranty Company.

Australian Consumer Law: Australian customers will find details relating to the Australian Consumer Law either inside the box or at your local Toro Dealer.