



MODEL NO. 56138 - 8000001 & UP
MODEL NO. 56145 - 8000001 & UP

OPERATOR'S MANUAL

8 hp (6 KW) REAR ENGINE RIDER
RECOIL & ELECTRIC START

The Rear Engine Rider meets or exceeds the American National Standards Institute's safety standards for riding mowers; thus Toro proudly displays the OPEI safety seal.



To assure maximum safety, optimum performance, and to gain knowledge of the mower, it is essential that you or any other operator of the mower read and understand the contents of this manual before the engine is started. Pay particular attention to the instructions highlighted by the triangular safety alert symbol. Failure to comply with the safety instructions may result in personal injury.

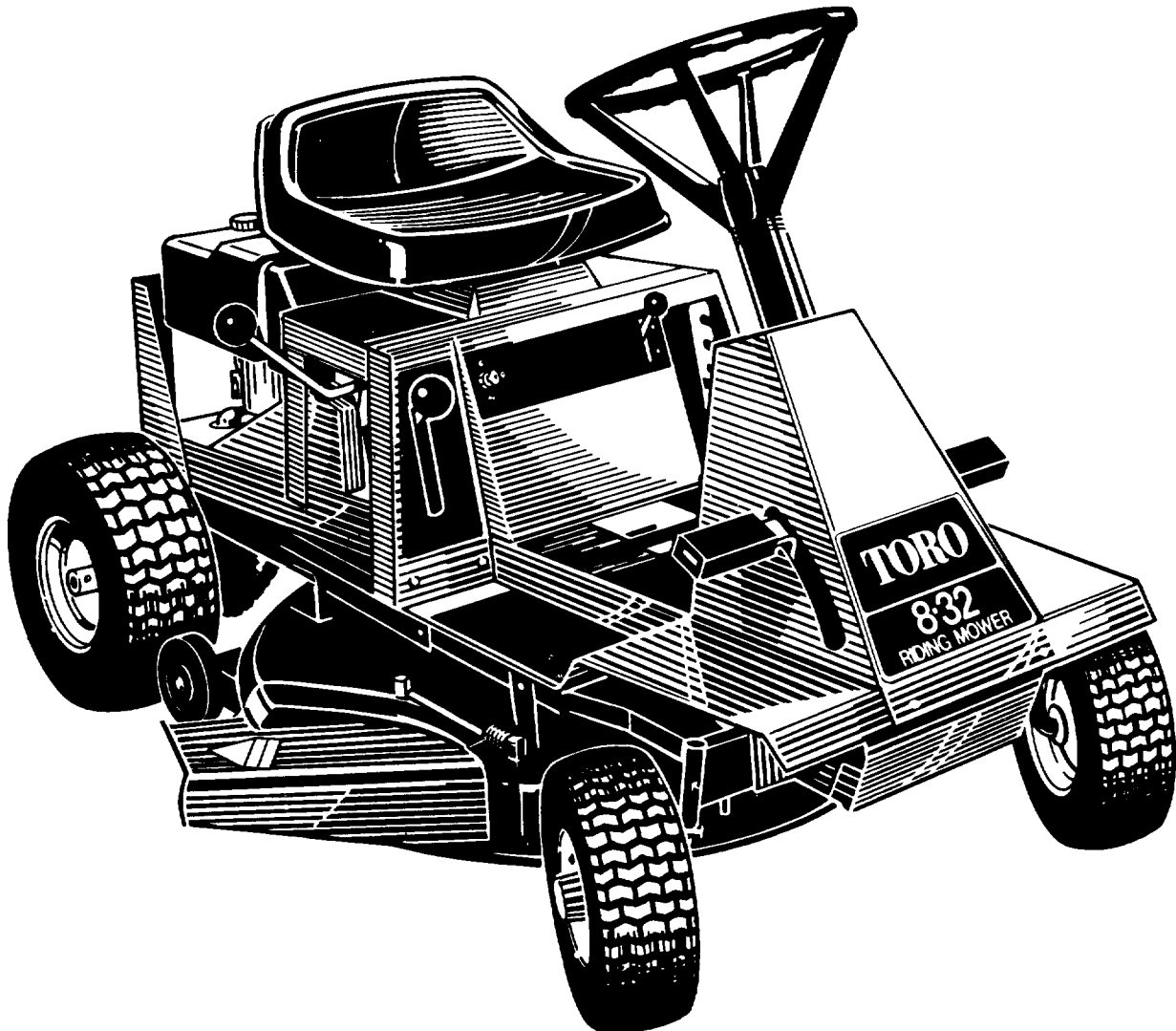

FOREWORD

The Rear Engine Rider rotary mower has advanced concepts in engineering, design, and safety; and if maintained properly, the product will be reliable.

Since the rider is a high-quality product, Toro is concerned about the future use of the mower and the safety of the user. Therefore, read this manual to familiarize yourself with the safety instructions and the product before operating the rider or mower. The six major sections of the manual are:

- | | |
|--------------------------------|---------------------------|
| 1. Safety Instructions | 4. Operating Instructions |
| 2. Setting Up Instructions | 5. Maintenance |
| 3. Preparation Before Starting | 6. Trouble Shooting |

Note that safety, mechanical, and some general information in the manual is emphasized. The words CAUTION, WARNING, DANGER, IMPORTANT, and NOTE are used to classify the information. CAUTION, WARNING and DANGER identify safety related information; IMPORTANT identifies special mechanical information; and NOTE identifies general information worthy of special attention.

When mower is used or operated on any California forest, brush or grass covered land, a working order spark arrester must be attached to muffler. If not, the operator is violating state law, Section 4442 Public Resources Code.

If help — concerning set-up, operation, maintenance, or safety — is ever needed, contact the local Authorized TORO Service Dealer or Distributor. Refer to the "Yellow Pages" for assistance. In addition to skilled service technicians, the dealer and distributor have other TORO Products, as well as factory approved accessories and replacement parts. Keep your Toro all TORO. Buy genuine TORO replacement parts and accessories.

TABLE OF CONTENTS

	Page		Page
Safety Instructions	3-4	Servicing Air Cleaner	16
Safety Decals	5	Replacing Spark Plug	17
Specifications	6-7	Draining Gasoline From Fuel Tank	17
Loose Parts	7	Adjusting Throttle/Choke Control	17
Setting Up Instructions	8	Adjusting Carburetor	18
Install Front Wheels	8	Servicing Cutter Blade	18
Install Steering Wheel	8	Cleaning Underside of Mower Housing	19
Install Seat	8	Removing/Installing Cutting Unit	20
Before Operating	9-10	Replacing Blade Drive Belt	20
Activating and Charging Battery	9	Adjusting Blade Drive Belt	21
Check Crankcase Oil Level	9	Replacing Traction Drive Belt	21
Check Tire Pressure	10	Adjust Drive Chain	21
Fill Fuel Tank With Gasoline	10	Adjusting Front Wheel Alignment	22
Controls	11	Adjusting Brake	22
Starting and Stopping Instructions	12	Leveling Cutting Unit	23
Operating Instructions	13	Adjusting Gear Shift Neutral Position	23
Grass Deflector	13	Checking Electrical Connections	23
Operating Procedure	13	Checking Safety Interlock System	24
Grass Cutting Tips	13	Preparing Mower For Storage	24
Maintenance Interval Chart	14	Wiring Diagram	25
Maintenance	14-26	Trouble Shooting	26-27
Grease Front Axle Spindles and Wheels	14	Product Identification	Back Cover
Lubricate Pivot Points	15	The Toro Promise	Back Cover
Changing Crankcase Oil	15		

SAFETY INSTRUCTIONS

The Rear Engine Rider was tested and verified by an independent laboratory for compliance with the B71.1 — 1986 specifications of the American National Standards Institute.

Improper use or maintenance by the operator or owner of the mower can result in personal injury. To reduce the potential for injury, follow these safety instructions.

BEFORE OPERATING

1. Read and understand the contents of this manual or instructions furnished with attachments, before starting and operating the rider, mower or attachment. Become familiar with all controls and know how to stop the engine quickly. **NEVER ALLOW CHILDREN TO OPERATE THE MACHINE.**

2. Keep everyone, especially children and pets, away from the area of operation. Remove sticks, stones, wire, and any other debris or objects which might be picked up and thrown by the mower.

3. Keep all shields and safety devices in place. If a shield, safety device or decal is defective or damaged, repair or replace it before operation is commenced. Also tighten any loose nuts, bolts and screws.

4. Wear long pants and substantial shoes. Do not operate the rider while bare foot, wearing sandals, tennis shoes, sneakers, or shorts.

5. Fill fuel tank with gasoline before starting the engine. Avoid spilling any gasoline. Since gasoline is highly flammable, handle it carefully.

A. Use an approved gasoline container.

B. Do not fill fuel tank indoors, when the engine is running, or until engine cools for several minutes after running.

C. Open doors if engine will be run in the garage because exhaust fumes are dangerous and could possibly be deadly. Do not run engine indoors.

D. Wipe up any gasoline that spilled, and install gasoline container cap and rider fuel tank cap before starting the engine.

6. Before attempting to start the engine, shift into neutral, move deck engagement lever into **DISENGAGE** position and move height-of-cut control to highest cutting level. Engine will not start when transmission is in gear or deck engagement lever is in the **ENGAGE** position.

7. Assure interlock system is operating correctly before each use of the rider. Have all safety related

components and safety interlock system checked by an Authorized TORO Service Dealer every two years to assure safe operation of the rider.

WHILE OPERATING

8. Never carry passengers on the rider.

9. Keep people and pets a safe distance away from the rider and area of operation.

10. Start engine when parking brake is set, blade is disengaged and transmission is in neutral.

11. Using a riding mower demands attention; therefore, mow only in daylight or when there is good artificial light. Stay alert for holes in the terrain and other hidden hazards. Do not drive close to a ditch, creek, or dropoff to prevent tipping or loss of control.

12. Cut steep grass slopes up and down; never across the face. When going uphill or downhill do not stop or start suddenly. Reduce speed on slopes and when making sharp turns to prevent tipping or loss of control. Extreme caution must be used when changing direction on slopes. If a steep hill must be ascended, back the rider up the hill and drive forward when descending.

13. Watch out for traffic when crossing or near roads. Always yield the right-of-way.

14. Keep face, hands, feet, or any other part of the body and clothing away from concealed, moving, or rotating parts such as the cutter blade, discharge area, wheels, chain, belts, and engine. Always sit on the seat while operating the rider and mower.

15. During operation the grass deflector or complete rear grass catcher assembly must be installed on mower housing and rider. Move deck engagement lever into **DISENGAGE**, shift into neutral, set parking brake, and shut engine off before removing the rear grass catcher hopper or unclogging discharge chute or tube. Use a stick to remove any obstruction.

16. When driving from one area to another, crossing a gravel driveway, road, or sidewalk, move deck engagement lever into **DISENGAGE** and raise mower housing to its highest level. This will prevent loose sand, rocks, and other debris from being thrown by the whirling blade.

17. Before backing up, move deck engagement lever into **DISENGAGE**. Do not mow in reverse unless absolutely necessary and then only after careful observation of the entire area behind the mower.

18. Do not touch engine while it is running or soon after it is stopped because the engine may be hot enough to cause a burn.

SAFETY INSTRUCTIONS

19. Use only the drawbar hitch point at rear of chassis to pull the lightweight cart that is sold as an accessory. Limit loads to those that can be controlled safely. Be very careful when backing and turning: never turn sharply.

20. Before leaving the operator's position — on the seat — or leaving rider unattended, shift transmission into neutral, set parking brake, move deck engagement lever into DISENGAGE, rotate ignition switch to OFF, and remove key from switch.

21. If the blade strikes a solid object or mower vibrates abnormally, shift transmission into neutral, set parking brake, move deck engagement lever into DISENGAGE, rotate ignition key to OFF, and remove key from switch. Disconnect high tension wire from spark plug and keep wire away from the plug to prevent possibility of accidental starting. Check rider and mower for possible damage, bent blade, defective belt or chain, an obstruction, and a loose blade or other parts. Make all repairs before restarting the engine and operating the mower.

MAINTAINING MOWER

22. Before storing the rider, or performing any maintenance service and adjustment, shift transmission into neutral, set parking brake, move deck engagement lever into DISENGAGE, rotate ignition key to OFF and remove key from switch. Keep the key in a memorable place so it is not lost accidentally. Also disconnect high tension wire from spark plug to prevent possibility of accidental starting.

23. Perform only those maintenance instructions described in this manual. If major repairs are ever needed or assistance is desired, contact an Authorized TORO Service Dealer.

24. If rider and mower must be tipped to perform maintenance or an adjustment, drain gasoline from fuel tank, oil from crankcase, and remove the battery.

25. Keep rider and mower housing in safe operating condition. Check drive chain adjustment and condition. Keep nuts, bolts, and screws tight. Check the blade mounting nut frequently to assure the nut is tight (45 - 60 ft-lb).

26. To reduce potential fire hazard, make sure engine is free of excessive grease, grass, leaves and dirt.

27. Under normal usage the optional grass catcher is subject to deterioration and wear. Frequently check all components of grass catcher including bag material, discharge chute, and duct for wear, damage, or deterioration and replace if necessary with genuine TORO parts.

28. Allow engine to cool before storing rider in any enclosure such as a garage or storage shed, and make sure the rider fuel tank is empty if rider is to be stored in excess of 30 days. Do not store rider near any open flame or where gasoline fumes may be ignited by a spark. Always store gasoline in a safety-approved, red metal container.

29. Do not overspeed the engine by changing governor settings. To assure safety and accuracy, have an Authorized TORO Service Dealer check maximum engine speed (3400 rpm) with a tachometer.

30. At the time of manufacture, the rider conformed to safety standards in effect for riding mowers. Therefore, to assure optimum performance and safety, purchase genuine TORO replacement parts and accessories to keep the Toro all TORO. NEVER USE "WILL-FIT" REPLACEMENT PARTS AND ACCESSORIES. The TORO logo assures genuine TORO replacement parts and accessories.

SAFETY DECALS



Safety decals and instructions are easily visible to the operator and are located near any area of potential danger. Replace any decal that is damaged.

ON DEFLECTOR
(Part No. 54-9220)



ON REAR OF STEERING TOWER
(Part No. 56-7810)

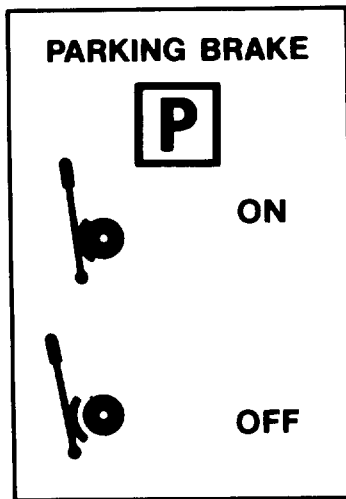

ON RIGHT SIDE OF SEAT
(Part No. 44-7260)

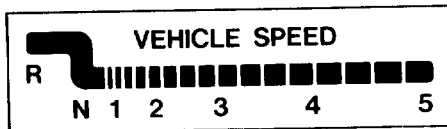

IN FRONT OF SEAT
(Part No. 56-7820)

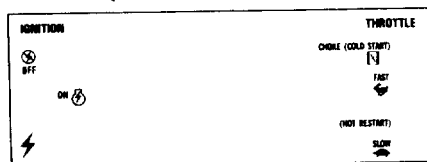

IN FRONT OF SEAT
(Part No. 56-7840)

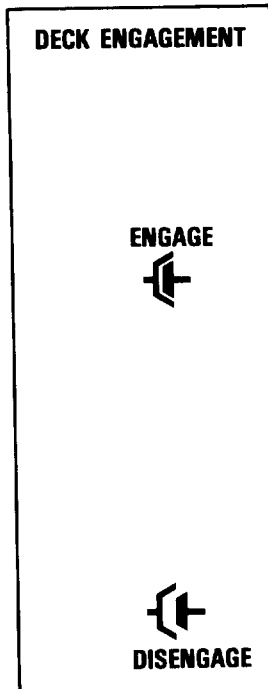

IN FRONT OF SEAT
(Part No. 56-7830)

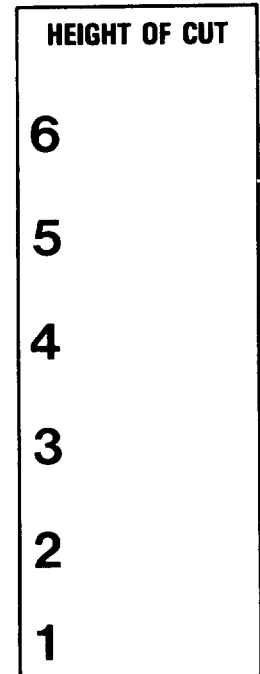

CLUTCH PEDAL

DEPRESS CLUTCH WHEN SHIFTING INTO GEAR OR CHANGING GEARS.

P **PARKING BRAKE**
TO APPLY PARKING BRAKE:

- MOVE SHIFT SELECTOR TO NEUTRAL.
- DEPRESS BRAKE AND CLUTCH PEDALS.
- LIFT PARKING BRAKE LEVER TO "ON" POSITION.
- RELEASE BRAKE AND CLUTCH PEDAL.

TO DISENGAGE PARKING BRAKE:

- DEPRESS BRAKE PEDAL AND/OR CLUTCH PEDAL.
- PUSH DOWN ON PARKING BRAKE LEVER.

PARKING BRAKE MUST BE RELEASED BEFORE SHIFTING INTO FORWARD GEAR.

BRAKE PEDAL

TO START ENGINE:
NOTE: ENGINE WILL START ONLY WITH GEAR SHIFT IN NEUTRAL AND DECK ENGAGEMENT LEVER IN DISENGAGE POSITION.

- SET PARKING BRAKE TO "ON" POSITION.
- GEAR SELECTOR MUST BE IN NEUTRAL "N" POSITION.
- DECK ENGAGEMENT LEVER MUST BE IN "DISENGAGED" POSITION.
- MOVE THROTTLE LEVER TO "CHOKE" POSITION.
- ELECTRIC START: OPERATOR MUST BE PROPERLY SEATED ON VEHICLE. TURN IGNITION TO "START" POSITION. RELEASE WHEN ENGINE STARTS.
- RECOIL START: TURN IGNITION TO "ON" POSITION. PULL ROPE TO START ENGINE.

TO STOP ENGINE:

- PLACE ALL CONTROLS IN NEUTRAL OR DISENGAGE POSITION.
- SET PARKING BRAKE.
- TURN IGNITION SWITCH TO OFF.

TO STOP VEHICLE:

- FULLY DEPRESS CLUTCH AND BRAKE PEDALS.

HEIGHT OF CUT

CAUTION
TO AVOID INJURY

- NEVER OPERATE WITH GUARD DOWN.
- NEVER OPERATE WITH GUARD DOWN ON ANY PART OF YOUR BODY OR ANY OTHER PERSON'S BODY.
- NEVER OPERATE WITH GUARD DOWN ON ANY PART OF YOUR FACE OR HEAD.
- NEVER OPERATE WITH GUARD DOWN ON ANY PART OF YOUR HANDS OR FEET.
- NEVER OPERATE WITH GUARD DOWN ON ANY PART OF YOUR CLOTHING.
- NEVER OPERATE WITH GUARD DOWN ON ANY PART OF YOUR HAIR.
- NEVER OPERATE WITH GUARD DOWN ON ANY PART OF YOUR EYES.
- NEVER OPERATE WITH GUARD DOWN ON ANY PART OF YOUR EARS.
- NEVER OPERATE WITH GUARD DOWN ON ANY PART OF YOUR MOUTH.
- NEVER OPERATE WITH GUARD DOWN ON ANY PART OF YOUR NOSE.
- NEVER OPERATE WITH GUARD DOWN ON ANY PART OF YOUR THROAT.
- NEVER OPERATE WITH GUARD DOWN ON ANY PART OF YOUR NECK.
- NEVER OPERATE WITH GUARD DOWN ON ANY PART OF YOUR CHEST.
- NEVER OPERATE WITH GUARD DOWN ON ANY PART OF YOUR BACK.
- NEVER OPERATE WITH GUARD DOWN ON ANY PART OF YOUR SHOULDERS.
- NEVER OPERATE WITH GUARD DOWN ON ANY PART OF YOUR ARMS.
- NEVER OPERATE WITH GUARD DOWN ON ANY PART OF YOUR LEGS.
- NEVER OPERATE WITH GUARD DOWN ON ANY PART OF YOUR FEET.
- NEVER OPERATE WITH GUARD DOWN ON ANY PART OF YOUR HANDS OR FEET.
- NEVER OPERATE WITH GUARD DOWN ON ANY PART OF YOUR CLOTHING.
- NEVER OPERATE WITH GUARD DOWN ON ANY PART OF YOUR HAIR.
- NEVER OPERATE WITH GUARD DOWN ON ANY PART OF YOUR EYES.
- NEVER OPERATE WITH GUARD DOWN ON ANY PART OF YOUR EARS.
- NEVER OPERATE WITH GUARD DOWN ON ANY PART OF YOUR MOUTH.
- NEVER OPERATE WITH GUARD DOWN ON ANY PART OF YOUR NOSE.
- NEVER OPERATE WITH GUARD DOWN ON ANY PART OF YOUR THROAT.
- NEVER OPERATE WITH GUARD DOWN ON ANY PART OF YOUR NECK.
- NEVER OPERATE WITH GUARD DOWN ON ANY PART OF YOUR CHEST.
- NEVER OPERATE WITH GUARD DOWN ON ANY PART OF YOUR BACK.
- NEVER OPERATE WITH GUARD DOWN ON ANY PART OF YOUR SHOULDERS.
- NEVER OPERATE WITH GUARD DOWN ON ANY PART OF YOUR ARMS.
- NEVER OPERATE WITH GUARD DOWN ON ANY PART OF YOUR LEGS.
- NEVER OPERATE WITH GUARD DOWN ON ANY PART OF YOUR FEET.

56 7800

DECK ENGAGEMENT

TO ENGAGE DECK RAISE LEVER TO DETENT. LEVER MUST BE IN DISENGAGE POSITION TO START ENGINE.

ON FLOOR PANEL
(Part No. 56-7800)

SPECIFICATIONS

832 REAR ENGINE RIDER — RECOIL START, MODEL 56138 832 REAR ENGINE RIDER — ELECTRIC START, MODEL 56145

8-32 Briggs & Stratton Engine (56138): Recoil start four cycle engine, has output of 8 hp (6 KW) @ 3600 rpm and 12.7 ft/lb (17.2 N·m) torque @ 2500 rpm. Displacement is 19.44 cubic inches (318.6 cc). Crankcase oil capacity is 2-1/4 pints (1.065 l) and fuel tank capacity is 5 quarts (1.3 l). Correct spark plug is a Champion RCJ-8, Autolite AR7N, or equivalent resistor type. Recommended spark plug air gap is 0.030 of an inch (0.762 mm).

8-32 — Briggs & Stratton Engine (56145): Electric start with alternator, four cycle engine, has output of 8 hp (6 KW) @ 3600 rpm and 12.7 ft/lb 17.2 N·m) torque @ 2500 rpm. Displacement is 19.44 cubic inches (318.6 cc). Crankcase oil capacity is 2-1/4 pints (1.065 l) and fuel tank capacity is 5 quarts (1.3 l). Correct spark plug is a Champion RCJ-8, Autolite AR7N, or equivalent resistor type. Recommended spark plug air gap is 0.030 of an inch (0.762 mm).

Mower Housing: Full floating, front to rear, side to side. 12 gauge (2.64 mm) stamped steel housing with right side discharge. Deck diameter is 31.75 inches (.0806 m). Steel spindle housing with shaft is supported by two double seal ball bearings. Blade spindle pulley is driven by "A" section V-belt from engine crankshaft.

Cutter Blade: Single blade is 31.35 inches (0.796 m) long, made of one piece hardened 7 gauge (2.72 mm) carbon steel.

Blade Tip Speed: 17,000 ft./min (86 360 m/s) @ 3300 engine rpm. Height of Cut Range: Height of cut is adjustable to one of six appropriate settings from 1-1/2 inches to 4 inches (38 to 101 mm).

Transmission: Transmission fully enclosed, permanently lubricated with five speeds forward and one reverse.

Gear Reductions:

1st — 7.0:1	4th — 2.4:1
2nd — 4.5:1	5th — 2.0:1
3rd — 3.0:1	Rev. — 4.2:1

Differential: Sintered powdered metal bevel gears are enclosed in a permanently lubricated housing. Axle shafts are 3/4 inch (19 mm) dia.

Wheels and Tires: The front 11 × 4.00-5 and the rear 15 × 6.00-6 tubeless, pneumatic turf tires are installed on demountable stamped steel wheels.

Grounded Speed @ 3300 Engine rpm:

1st gear — 1.55 mph (2.50 km/hr)
2nd gear — 2.41 mph (3.88 km/hr)
3rd gear — 3.61 mph (5.81 km/hr)
4th gear — 4.59 mph (7.39 km/hr)
5th gear — 5.42 mph (8.72 km/hr)
Rev. gear — 1.81 mph (2.92 km/hr)

Steering: 4 spoke, dished steering wheel on pinion and sector gear to tie rods controlling wheels 5.1:1 reduction. Turning diameter of Approximately 6.6 ft. (2 m).

Engine Controls: Control wire and casing with FAST, SLOW and CHOKE positions. key switch with ON, OFF and START positions (electric). Both controls mounted in convenient position.

Transmission Control: Hand operated lever on right side of operator with in line shifting pattern.

Traction Clutch: Foot operated pedal on left side. Depressing pedal disengages idler pulley.

Brake Pedal: Foot operated pedal on right side. Depressing pedal engages caliper on 2-1/2 inch (64 mm) diameter disc.

Parking Brake Control: Hand operated lever on rear of steering tower which locks brake pedal and/or clutch pedal.

Cutter Blade Control: Hand operated lever in front of operator releases blade brake and engages clutch.

Height-Of-Cut Control Lever: Hand Operated lever in front of operator. Height of cut selection is variable in six increments from 1-1/2 to 4 inches (38 to 102 mm).

SPECIFICATIONS

General Dimensions:

- Wheel Base — 45 in (1.14 m)
- Tread Width — 30 in (.76 m) front outside to outside
- Length — 58 in (1.48 m)
- Height — 38 in (.97 m)
- Width — 40 in (1.02 m)
- Weight — 335 lb (151.96 kg)
8-32 R (Model 56138)
— 360 lb (163.30 kg)
8-32 E (Model 56145)

Safety Features: Meets B71.1 — 1986 ANSI safety specifications.

- Traction drive, blade drive and seat interlock.
- Full foot rests.
- Convenient, easy to operate controls.
- Automatic blade brake.
- Stable-Wide track and low center of gravity.

Optional Accessories Attachments:

- Easy Empty Grass Catcher, Model #59111.
- Twin Bagger, Model #59184.

LOOSE PARTS

Note: Carefully remove rider and other parts from carton. Use chart below to assure all parts have been shipped.

DESCRIPTION	QTY.	USE
Seat	1	Install Seat, page 8.
Flangehead Capscrew	4	
Front Wheel Assembly	2	Install Front Wheels, page 8.
Flat Washer	2	
Hub Cap	2	
Cotter Pin	2	
Steering Wheel	1	Install Steering Wheel, page 8.
Roll Pin	1	
Steering Shaft Cover	1	
Key	2	Use in Ignition Switch.
Capscrew	2	Secure battery cables to battery, page 10.
Wing Nut	2	
Operator's Manual	1	Read manual before operating Rider.
Reg. Card	1	Fill out and mail to Toro.

SETTING UP INSTRUCTIONS

INSTALL FRONT WHEELS

Note: Grease axle shafts before installing wheels.

1. Install wheel onto axle.
2. Mount flat washer onto axle, insert cotter pin and open pin ends with pliers (Fig. 1).

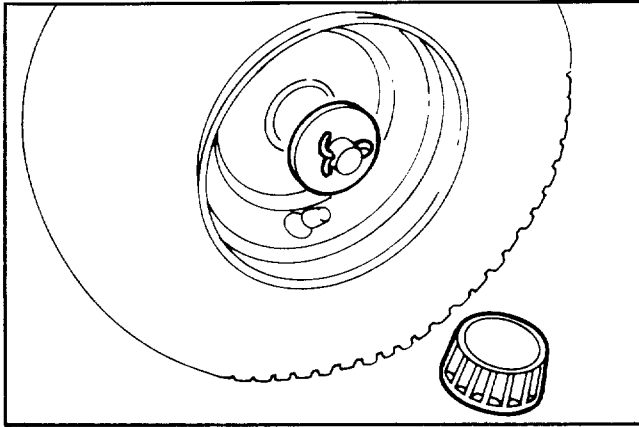

Figure 1

3. Install hub caps.
4. Repeat steps 1-3 on opposite side.
5. Check front and rear tires for 12 psi (82.7 kPa) inflation.
6. Lubricate both front wheels w/No. 2 general purpose grease. Pump grease gun until grease comes through bearings. Wipe up any excess grease.

INSTALL STEERING WHEEL ASSEMBLY

1. Position wheels in straight ahead direction and slide steering shaft cover over steering shaft.
2. Slip steering wheel over shaft and line the steering wheel mount hole with the shaft mounting hole. Toro Logo should be readable from operator's position.
3. Insert a drift punch partially through the holes to maintain alignment and insert the roll pin in from the opposite side.
4. Drive the roll pin in until it is flush with the outside of the wheel (Fig. 2).

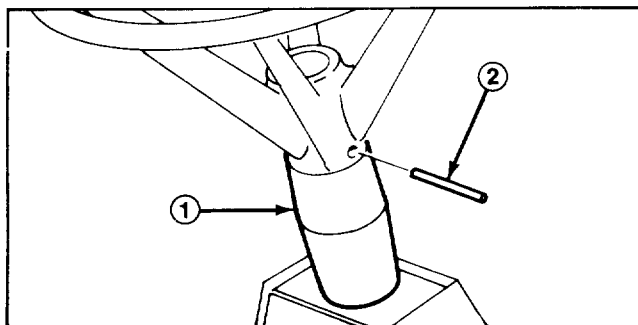

Figure 2

1. Steering Shaft Cover 2. Roll Pin

INSTALL SEAT

1. Position seat onto seat base, aligning mounting holes (Fig. 3).

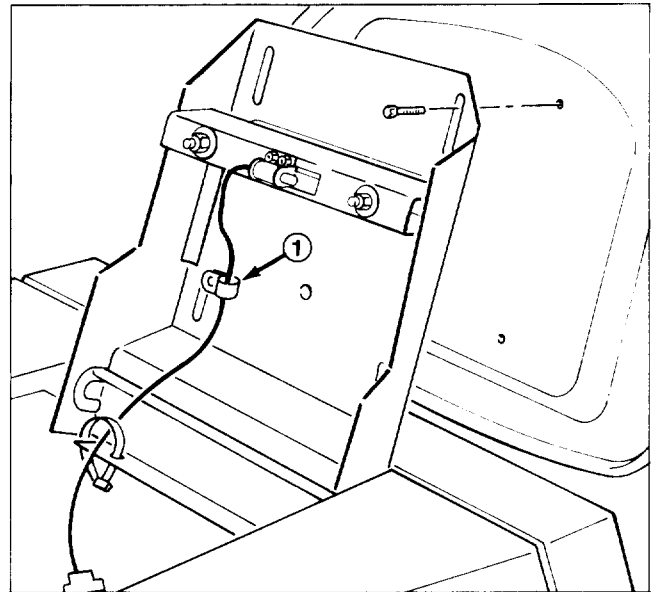

Figure 3

1. Wire Clamp

2. Using left front mounting slot in seat base, loosely secure wire clamp and seat to seat base with a Flangehead capscrew (Fig. 3).

3. Mount seat to seat base with (3) remaining Flangehead capscrews.

Note: Seat may be adjusted for operator comfort by positioning seat as desired in seat base slots.

4. Tighten all capscrews.

BEFORE OPERATING

ACTIVATING AND CHARGING BATTERY (Electric Start Riders Only)

Since the battery for the rider is not filled with electrolyte or activated, the battery, if you have not already done so, must be removed from the machine so it can be filled with electrolyte and charged. Bulk electrolyte with 1.260 specific gravity must be purchased from a local battery supply outlet. Remove the battery and activate it as follows:



CAUTION

Wear safety goggles and rubber gloves when working with electrolyte. Charge the battery in a well ventilated place so gases produced while charging can dissipate. Since the gases are explosive, keep open flame and electrical spark away from the battery; do not smoke. Nausea may result if the gases are inhaled. Unplug charger from electrical outlet before connecting to or disconnecting charger leads from battery posts.

1. Tip seat forward exposing battery.
2. Remove wing nut securing battery hold downs to rider chassis. (Fig. 4)

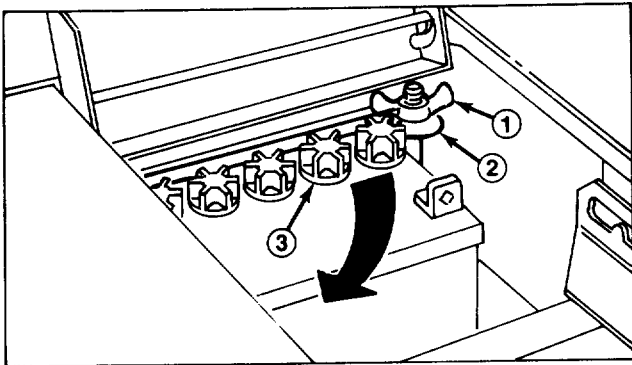

Figure 4

1. Wing Nut
2. Battery Hold Downs
3. Filler Cap

3. Lift up on top battery hold down and pivot rearward.
4. Remove battery from chassis and set it aside.
5. Remove filler caps from battery and slowly fill each cell until electrolyte is just above the plates. To obtain best results, let battery set for 20 minutes. Add electrolyte to the maximum capacity.
6. Leave filler caps off and connect a 3-4 amp battery charger to battery posts. Charge battery at a rate of 4 amperes or less for 4 hours (12 volt).

7. When battery is charged, disconnect charger from electrical outlet and battery posts.

8. Slowly add electrolyte to each cell until level is up to fill ring. Install filler caps.

IMPORTANT: Do not overfill battery. Electrolyte will overflow onto other parts and severe corrosion and deterioration will result.

9. Install the battery with the terminal posts toward the rear of the machine and vent tube on left side of battery, thru hole in frame (Fig. 5).

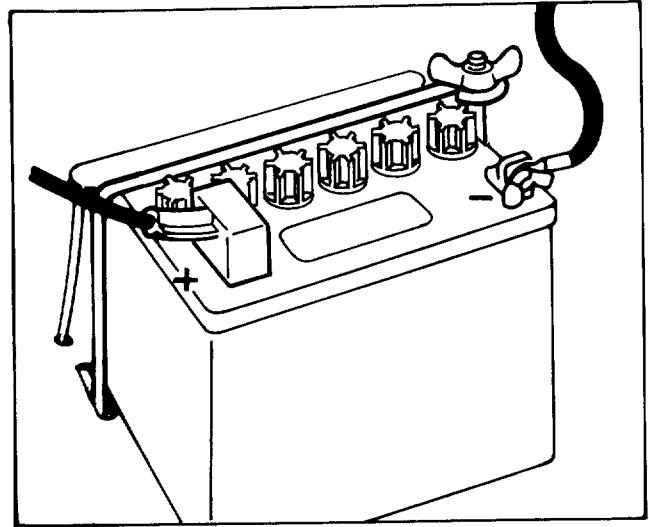

Figure 5

10. Reinstall battery hold downs.
11. Install the positive cable (rubber boot over end) to the positive (+) terminal and the negative cable (black) to the negative (-) terminal of the battery and secure with capscrews and wing nuts. Slide the rubber boot over the positive terminal to prevent possible short-out from occurring (Fig. 5).

CHECK CRANKCASE OIL LEVEL

The rider is shipped from the factory with oil in the crankcase. However, check the oil level in the crankcase prior to starting the engine.

1. Place rider on a level surface to assure accurate oil level reading.
2. Unscrew and remove the dipstick from the oil fill tube (Fig. 6).
3. If oil level is low, insert a funnel into the tube and slowly add engine oil into the crankcase. Use a high quality detergent oil classified "For Service SC, SD, SE, SF or "MS". Oil viscosity (weight) must be selected according to anticipated ambient temperature.

BEFORE OPERATING

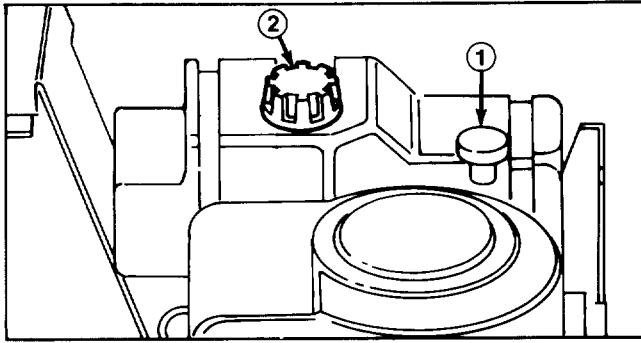

Figure 6

1. Dipstick
2. Fuel Tank Cap

- A. Above +40° F (4° C) — Use SAE 30; 10W-30 as a substitute.
- B. Below +40° F (4° C) — Use SAE 5W-20 or 5W-30; SAE 10W or 10W-30 as substitutes.
- C. Below 0° (-18° C) — Use SAE 10W or 10W-30 diluted 10% with kerosene (1.6 oz. per pint of oil).

Note: Avoid premature engine failure by insuring the funnel used is clean so contaminants are not introduced into the crankcase. Wipe any oil spilled, so it will not cause dirt to collect on the engine.

4. Insure the oil level is to the full mark on the dipstick when it is fully installed. Do not overfill or engine damage may result.

5. Insert the dipstick and turn it clockwise to secure it in the fill tube.

Note: Check the oil level every 5 operating hours or each time rider is used. Initially, drain the oil and replace it after the first 5 hours of operation to remove the contaminants produced by normal engine break-in; thereafter, under normal conditions, change oil after every 25 hours operation. Change the oil more frequently when the engine is operated in dusty or dirty conditons.

CHECK TIRE PRESSURE

Check and insure the tires are inflated to 13 psi (89.6 kpa) before operating the machine.

FILL FUEL TANK WITH GASOLINE



DANGER

Because gasoline is flammable, caution must be used when storing or handling it. Do not fill fuel tank while engine is running, hot or when machine is in an enclosed area. Vapors may build up and be ignited by a spark or flame source many feet away. **DO NOT SMOKE** while filling the fuel tank to prevent the possibility of an explosion. Always fill fuel tank outside and wipe up any spilled gasoline before starting engine. Use a funnel or spout to prevent spilling gasoline, and fill tank to about 1/2 inch (13 mm) below the filler neck. Store gasoline in a cool, well-ventilated place; never in an enclosed area such as a hot storage shed. To assure volatility, do not buy more than a 30 day supply of gasoline. Gasoline is a fuel for internal combustion engines; therefore, do not use it for any other purpose. Since many children like the smell of gas, keep it out of their reach because the fumes are explosive and dangerous to inhale.

The Toro Company strongly recommends the use of clean, fresh *Unleaded Regular Gasoline* in Toro Gasoline Powered Products. Unleaded gasoline burns cleaner, extends engine life, and promotes good starting by reducing the build-up of combustion chamber deposits. Leaded gasoline can be used if unleaded is not available.

Note: Never use *Methanol*, gasoline containing *Methanol*, gasohol containing more than 10% ethanol, gasoline additives, premium gasoline, or white gas because engine fuel system damage could result.

1. Clean area around fuel tank cap so foreign matter cannot enter tank when cap is removed (Fig. 6).
2. Remove cap from fuel tank and fill tank with unleaded gasoline. Then install fuel tank cap.
3. Wipe up any gasoline that may have spilled.

CONTROLS

Gear Shift (Fig. 7) — Transmission has five forward speeds, neutral and reverse. Single lever in-line shifting with "Z" pattern located at right side of operator. An interlock switch, which prevents engine from being started when transmission is in gear, is mounted on top of transmission.

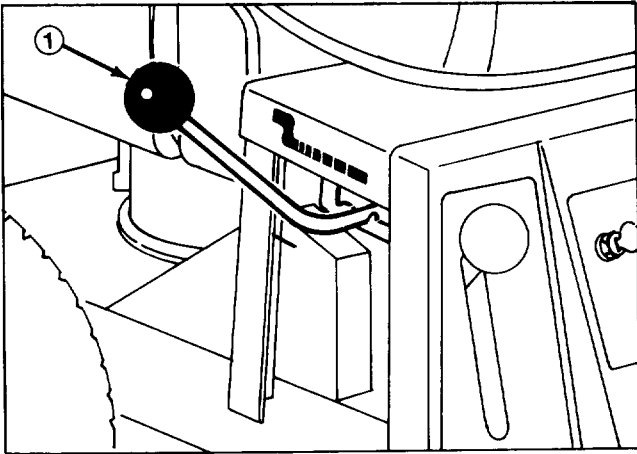

Figure 7
1. Gear Shift

Clutch Pedal (Fig. 8) — Foot-operated clutch pedal is used in conjunction with gear shift. Depress clutch pedal fully when shifting gears, which moves idler pulley away from traction drive belt and disengages engine power to wheels. Depress clutch pedal whenever brake is used.

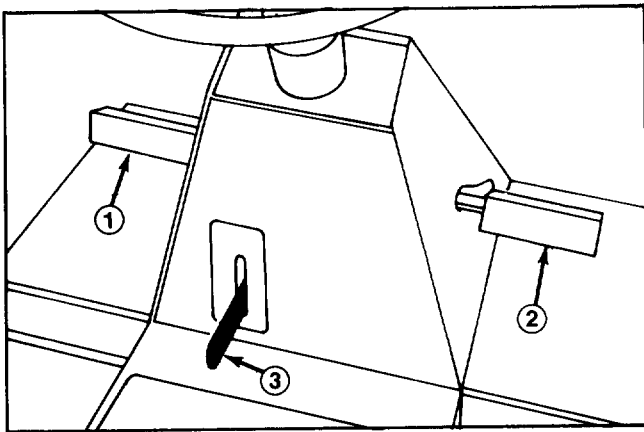

Figure 8
1. Clutch Pedal 3. Parking Brake
2. Brake Pedal

Brake Pedal (Fig. 8) — Foot-operated brake pedal must be depressed to slow down or stop the rider. When pedal is depressed, a caliper engages the brake disc at side of transmission. Remember to depress clutch pedal when using brake.

Parking Brake (Fig. 8) — Parking brake must be used in conjunction with clutch and brake pedals. When pedals are depressed, end of parking brake lever holds brake and clutch pedals in depressed position, a caliper engages the brake disc at side of transmission.

Deck Engagement Lever (Fig. 9) — Deck engagement lever engages and disengages the cutter blade. An interlock switch, which is mounted on front of seat base, prevents engine from starting when control is in the ENGAGE position. Engine will start when control is in DISENGAGE position only.

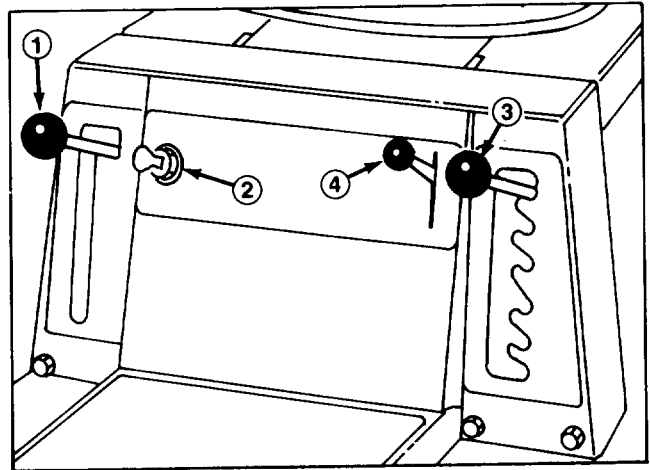

Figure 9
1. Deck Engagement Lever
2. Ignition Switch
3. Height-of-Cut Control
4. Throttle Control

Ignition Switch (Fig. 9) — Switch is part of engine ignition system, and it has three positions: OFF, ON and START. Key automatically returns to ON position from START position when released after engine starts.

Height-of-Cut Control (Fig. 9) — Height-of-cut control varies the cutting height from 1-1/2 to 4 inches (38 to 102 mm) in six increments.

Throttle Control — (Fig. 9) — Throttle control connects to and operates carburetor mounted throttle and choke. Control has three positions: SLOW, FAST and CHOKE. Push control slightly to the left and upward to obtain CHOKE position.

Recoil Starter (Fig. 10) (Recoil Models Only) — Recoil starter must be used in conjunction with ignition switch. After turning ignition key to ON position, pull recoil starter handle to start engine.

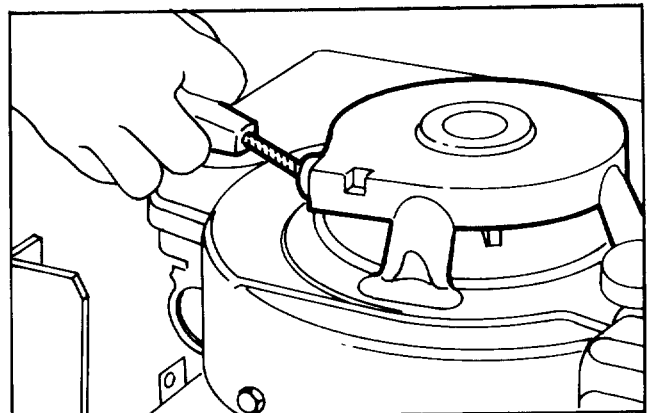

Figure 10

STARTING AND STOPPING INSTRUCTIONS

Note: Engine will not start unless deck engagement lever is DISENGAGED, and shift lever is in NEUTRAL.

START AND OPERATE MACHINE (Electric Start Models)

1. Sit on seat, shift into neutral, move deck engagement lever to DISENGAGE.
2. Move throttle control to CHOKE position and rotate ignition key to START. When engine starts, release key and move throttle control between FAST and SLOW.
3. Select desired height-of-cut and move deck engagement lever to ENGAGE.
4. Release parking brake, depress clutch pedal and shift into gear.

(Recoil Start Model)

1. Shift into neutral, move deck engagement lever to DISENGAGE.
2. Move throttle control to CHOKE position, and rotate ignition key to ON. Stand to left side of rider, pull recoil starter handle out until positive engagement results; then pull handle vigorously to start engine (Fig. 10). When the engine starts, immediately move throttle control between FAST and SLOW positions if choke was used for starting. Get onto the rider from the left side and sit on the seat.

IMPORTANT: Do not pull recoil rope to its limit or let go of the starter handle when rope is pulled out because rope may break or recoil assembly may be damaged.

3. Select desired height-of-cut and move blade control to ENGAGE.
4. Release parking brake, depress clutch pedal and shift into gear.

TO STOP

1. Depress brake and clutch pedals, move throttle control lever to SLOW position, move deck engagement lever to DISENGAGE, and rotate ignition key to OFF.

2. Shift transmission to neutral and engage parking brake.
3. Remove key from ignition switch.

BREAK-IN

The engine requires no special break-in other than changing oil after the first five hours of operation. Operate the transmission in all gears to assure that drive system is functioning correctly. After the first five hours of operation, check the condition of the belts and drive chain.

USING PARKING BRAKE



1. Depress brake and clutch pedals fully, shift transmission to neutral.
2. Move parking brake control upward and release brake and clutch pedal.
3. To release the parking brake, depress brake and clutch pedal, and push parking brake lever down to return it to its disengaged position. Release brake pedal slowly.

ADJUSTING HEIGHT-OF-CUT

The height-of-cut may be set in one of six positions from approximately 1-1/2 to 4 inches (38 to 102 mm).

1. Assure the deck engagement lever is in DISENGAGE position.
2. Move height-of-cut control into desired setting.
3. To engage blade for cutting, move deck engagement lever to ENGAGE.

OPERATING INSTRUCTIONS

GRASS DEFLECTOR



WARNING

The grass deflector and toe bar is a safety device that routes discharged material down toward the turf; therefore, do not remove deflector from mower housing. If the deflector is ever damaged, replace it. Without the deflector or complete grass catcher assembly mounted in place, discharged material could cause personal injury or blade contact could occur.

OPERATING PROCEDURE



WARNING

If drive chain comes off sprockets, there are no brakes or traction drive. Check chain adjustment and condition regularly. (Refer to Adjusting Drive Chain, page 21.)

1. Move deck engagement lever into DISENGAGE.
2. Start the engine: refer to Starting/Stopping Instructions.

IMPORTANT: When rider is used for the first time, operate the transmission in all gears to assure that drive system is functioning correctly, and become familiar with the controls and operating characteristics. Never shift while the machine is moving or without first depressing the clutch pedal or transmission damage could result.

3. Depress clutch pedal and shift transmission into 1st gear. Then release pedal slowly until traction drive engages.

IMPORTANT: To avoid a jerky start and putting a heavy load on the transmission, release clutch pedal slowly. If shifting into reverse gear is difficult, jog clutch pedal in and out to get gears to mesh. Do not force the gear shift because damage may result. Should you encounter a jerking or grabbing condition during operation, contact your local Authorized TORO Service Dealer for assistance.



WARNING

To avoid loss of control, always come to a complete stop before shifting gears, and slow down when turning, backing and changing direction. Look behind the tractor to assure area is clear before backing.

4. To engage blade for cutting, move height-of-cut control to the desired setting, then move deck engagement lever to ENGAGE.

5. To stop engine, in sequence, depress clutch and brake pedals, move throttle control to SLOW, deck engagement lever into DISENGAGE, gear shift into neutral, engage parking brake, and rotate key to OFF position.

GRASS CUTTING TIPS

1. When the rider is used to cut a lawn for the first time, cut grass slightly longer than normal to assure that cutting width of mower housing will not cause scalping, which could result from severe undulations of the ground. In general, however, the cutting height used in the past is probably the best one to use.

2. If the grass is ever allowed to grow slightly longer than normal, or if it contains a high degree of moisture, raise cutting height higher than usual and cut the grass at this setting. Next, cut the grass again using the lower, normal setting. This method of cutting long grass results in an even distribution of clippings and an acceptable quality-of-cut.

3. Very long or extremely wet grass can be cut, but specific operating techniques must be used. Start by setting height-of-cut in the highest position. Using 1st gear and maximum throttle speed, move into the grass and cut a swath that is only half as wide as the mower housing. Direct grass clippings toward area that was cut previously. Stop forward movement occasionally to allow discharge area to clear itself. Cutting too much grass may clog the mower housing and discharge area. If mower housing does clog, shut engine off, disengage deck and remove the obstruction with a stick.



DANGER

Before removing obstruction from mower housing, move deck engagement lever into DISENGAGE, depress clutch and brake pedals, shift into neutral, turn ignition key to OFF position and set parking brake. Remove high tension wire from spark plug to prevent possibility of accidental starting.

4. When mowing, operate engine at full throttle. This maintains proper blade speed and air flow to facilitate discharge of clippings. Mowing with a lower rpm causes the blade to tear the grass, resulting in poor lawn appearance. Lower rpm also reduces alternator charging efficiency which may affect battery performance.

MAINTENANCE INTERVAL CHART

	5 Hours	10 Hours	25 Hours (Monthly)	Storage Service	Spring Service	2 Years	Notes
Change Oil (Initial)	X						
Change Oil (Periodic)			X	X			
Check Safety Interlock	X		X		X		
Check Cutter Blade	X		X	X			
Check Brake	X			X	X		
Grease Front Axle Spindles			X	X			More often in dusty, dirty, conditions.
Lubricate Pivot Points			X	X			
Service Air Cleaner		X		X			
Check Spark Plug			X	X	X		
Check Blade Drive Belt				X			
Check Traction Drive Belt				X			
Check Drive Chain	X		X	X	X		More often in dusty, dirty, conditions.
Drain Gasoline				X			
Clean Outside of Engine				X			
Clean Mower Housing				X			
Paint Chipped Surfaces				X			
Remove Rear Wheels and Grease Axle				X			
Check Interlock Switches						X	

MAINTENANCE

 **CAUTION**

To prevent accidental starting of the engine while performing maintenance, shut engine off and remove key from ignition switch. Also, pull wire off spark plug (Fig. 11). Make sure wire does not contact plug accidentally.

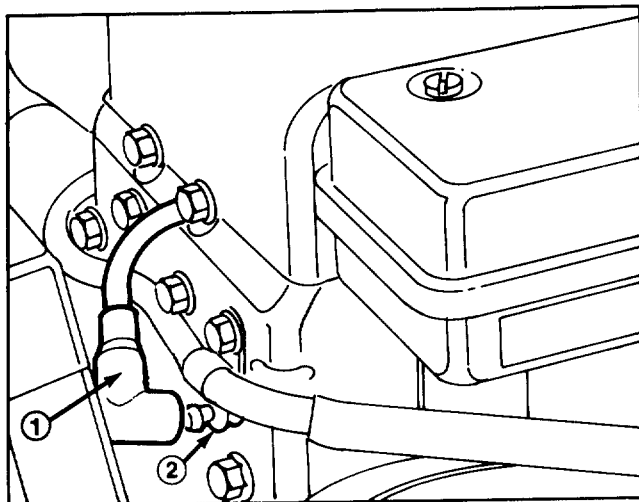

Figure 11

1. Spark Plug Wire 2. Spark Plug

GREASE FRONT AXLE SPINDLES AND WHEELS

The front axle spindles and wheels must be lubricated after every 25 hours of operation; however, lubricate more frequently when conditions are dusty or sandy.

1. Wipe grease fittings on spindles and wheels (Fig. 12) with a clean rag. If there is paint on front of fittings, scrape it off.

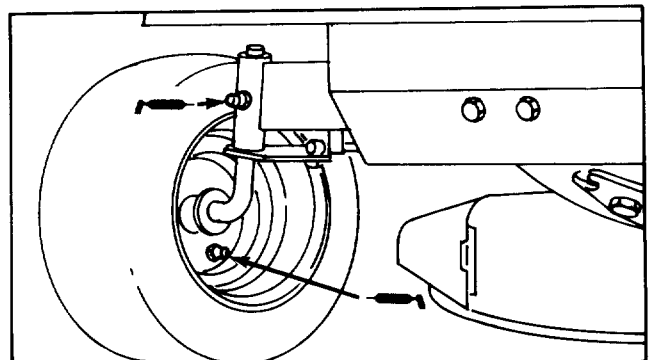

Figure 12

2. Lubricate both axle spindles w/No. 2 general purpose grease (Fig. 12). Continue to pump grease until it oozes out the spindle. Wipe up any excess grease.
3. Lubricate both front wheels w/No. 2 general purpose grease (Fig. 12). Pump grease gun about four times. Wipe up any excess grease.

MAINTENANCE

LUBRICATE PIVOT POINTS

The mechanical pivot points on the rider must be lubricated after every 25 hours of operation; however, lubricate more frequently when conditions are dusty or sandy.

IMPORTANT: To lubricate all the mechanical pivot points, the rider must be tipped on its rear end. However, before the rider is tipped, drain all gasoline from fuel tank and oil from crankcase. Also remove battery so acid does not spill onto the rider.

1. Drain gasoline from fuel tank: refer to Draining Gasoline From Fuel Tank, page 17.
2. Drain oil from crankcase: refer to Changing Crankcase Oil, steps 1-6 page 15.
3. Remove battery from chassis: refer to Activating and Charging Battery, page 9.
4. Shift transmission into 1st gear and engage parking brake.

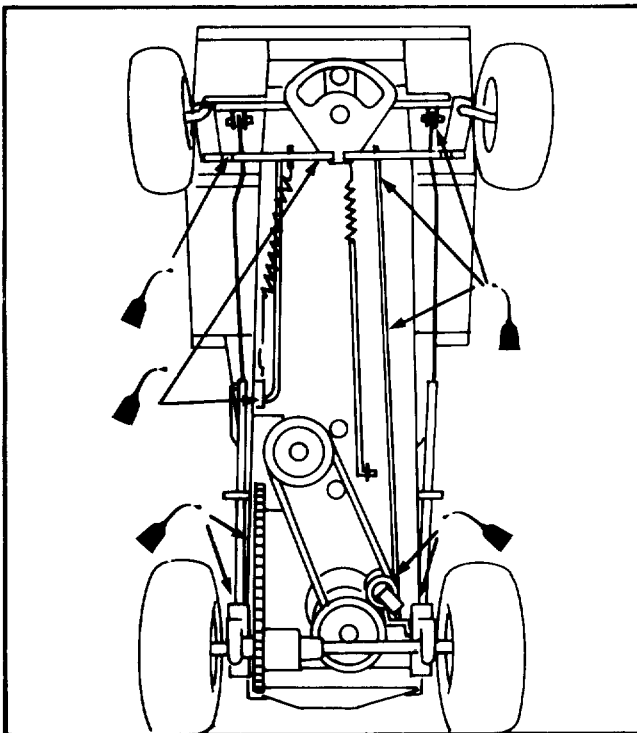

Figure 13

5. Remove mower housing from rider chassis: refer to Removing/Installing Cutting Unit, steps 1-5, page 21.
6. Tip rider up and onto its rear end.
7. Lubricate pivot points in the steering, drive, brake, clutch, and deck engagement linkage with light oil (Fig. 13). Also lubricate mower housing (Fig. 14). Wipe up any excess oil.

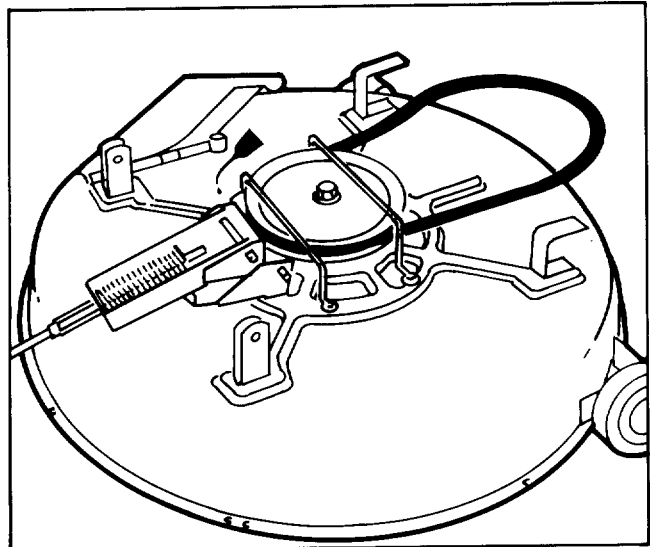

Figure 14

8. Tip rider back to its normal operating position.
9. Install mower housing onto rider chassis: refer to Removing/Installing Cutting Unit, page 20.
10. Fill crankcase with oil: refer to Check Crankcase Oil Level, page 9.
11. Fill fuel tank with gasoline: refer to Fill Fuel Tank With Gasoline, page 10.
12. Install the battery: refer to Activating and Charging Battery, steps 12-14, page 9.

CHANGING CRANKCASE OIL

1. Check level of oil before starting engine and after every 5 hours of operation. Maintain oil level at FULL mark on dipstick.

To check level of oil:

- A. Position rider on level surface.
- B. Clean the area around oil dipstick so foreign matter cannot enter filler hole when dipstick is removed.
- C. Unscrew dipstick and wipe oil off.
- D. Screw dipstick fully in to filler neck; then remove it and check oil level on dipstick. If level is low, add only enough oil to raise level to FULL mark. Do not overfill or engine damage may result.
- E. Screw dipstick back into filler neck.

MAINTENANCE

2. Change oil after first 5 hours of operation; every 25 hours thereafter. Change oil more frequently when operating conditions are extremely dusty or dirty.

To change oil:

- A. Position rider on level surface. Start and run engine for a period to warm the oil.
- B. Turn engine off and place drain pan below drain plug (Fig. 15). Support drain pipe with pipe wrench, remove drain plug, and allow all oil to flow into drain pan. Install drain plug after oil stops flowing.

Note: To ease removal of drain plug, use a $\frac{3}{8}$ " drive extension (6-12" long) with the square drive socket over the plug and turn with a crescent wrench.

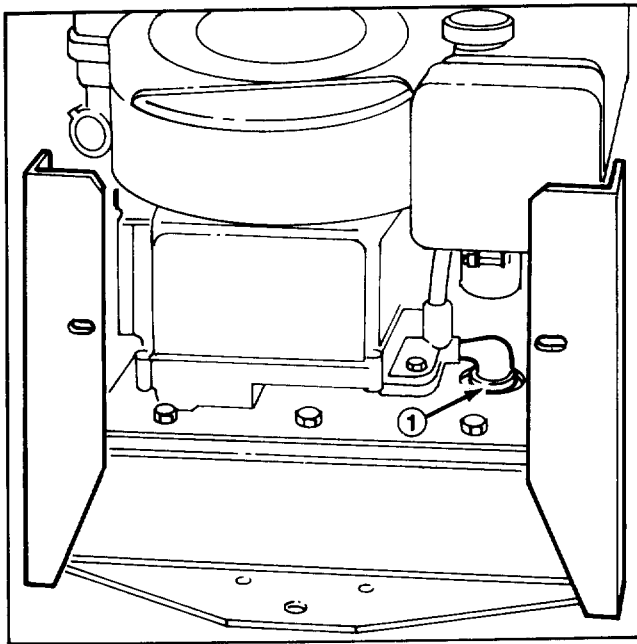

Figure 15
1. Drain Plug

- C. Unscrew dipstick and add oil to crankcase. Refer to CHECK CRANKCASE OIL LEVEL. Capacity of 8 hp (6 kw) rider crankcase is 36 oz. (1.065 l) and 11 hp (8.2 kw) rider is 48 oz. (1.42 l) DO NOT OVERFILL or engine damage may result.

SERVICING AIR CLEANER

The air cleaner element must be cleaned after every 25 hours engine operation if engine is operated in clean air conditions. However, element must be cleaned every few hours if operating conditions are extremely dusty or sandy.

1. Remove wire from spark plug.
2. Remove two screws and lift complete air cleaner assembly off carburetor (Fig. 16).

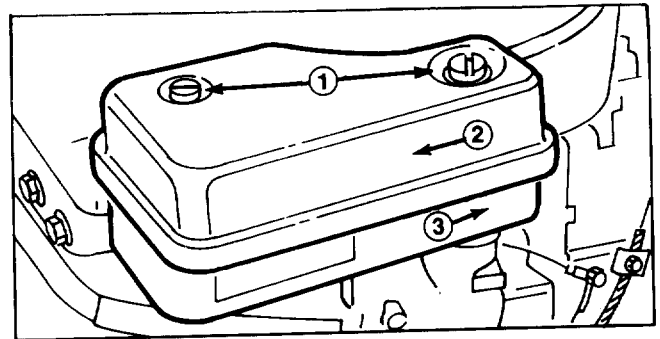

Figure 16
1. Screws
2. Cover
3. Body

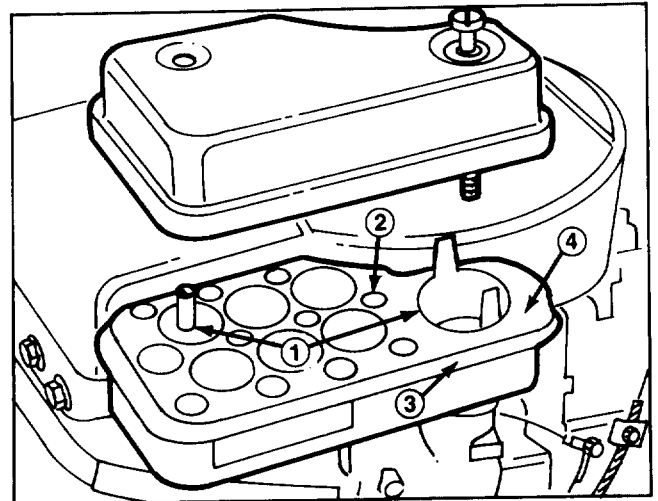

Figure 17
1. Spacers
2. Screen
3. Element Lip
4. Element

3. Remove cover and screen from foam element, remove spacers from element and element from body (Fig. 17). Examine element for dirt or discoloration and clean if necessary.
4. A. Wash foam element in solution of liquid detergent and water to remove dirt.
B. Wrap the element in cloth and squeeze it dry. Do not twist the element or it may tear.
C. Apply approximately 5 teaspoons (25 ml) of oil to the element, work the oil in until the whole element is impregnated and squeeze the element thoroughly to remove all excess oil.
D. Assemble the air cleaner assembly, mount it on the carburetor and secure it in place with the screws.

Note: When assembling make certain the lip of the foam element extends over the edge of the air cleaner body so it will form a protective seal.

MAINTENANCE

IMPORTANT: Always operate engine with air cleaner element in place or engine damage will result.

REPLACING SPARK PLUG

Since air gap between center and side electrodes of the spark plug increases gradually during normal operation of the engine, check condition of electrodes after every 25 operating hours. Recommended air gap is 0.030 of an inch (0.762 mm). Correct spark plug to use is:

Champion RCJ-8 or Autolite AR7N.

Note: The spark plug usually lasts a long time; however, the plug should be removed and checked whenever the engine malfunctions.

1. Clean area around spark plug so foreign matter cannot fall into cylinder when spark plug is removed.
2. Pull wire off spark plug and remove plug from cylinder head.
3. Check condition of side electrode, center electrode, and center electrode insulator to assure there is no damage.

IMPORTANT: A cracked, fouled, dirty or defective spark plug must be replaced. Do not sand blast, scrape, or clean electrodes by using a wire brush because grit may eventually release from the plug and fall into the cylinder. The result is usually a damaged engine.

4. Set air gap between center and side electrodes at 0.030 of an inch (0.762 mm) (Fig. 18). Install correctly gapped spark plug w/gasket seal, and tighten plug to 15 ft-lb (20.4 N·m). If torque wrench is not used, tighten plug firmly.

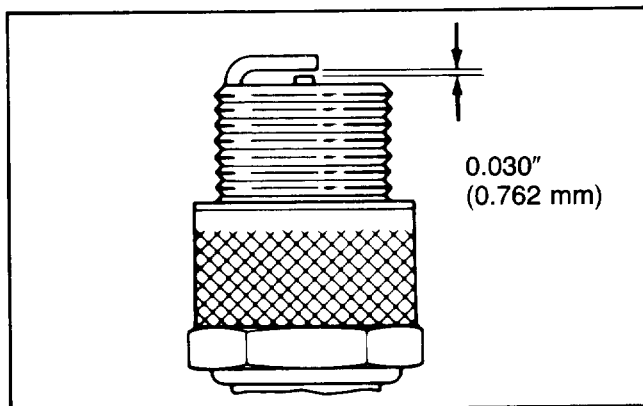

Figure 18

5. Push wire onto spark plug but do not leave key in the ignition. This will prevent accidental starting when mower is being stored between use periods. Keep key in memorable place so it is not lost.

DRAINING GASOLINE FROM FUEL TANK



CAUTION

Since gasoline is highly flammable, drain it outdoors and make sure engine is cool to prevent a potential fire hazard. Wipe up any gasoline that may have spilled. Do not drain gasoline near any open flame or where gasoline fumes may be ignited by a spark. Do not smoke a cigar, cigarette, or a pipe when handling gasoline.

IMPORTANT: When the rider is tipped, all gasoline must be drained from the fuel tank.

1. Clean area around fuel tank cap so foreign matter cannot enter filler hole when cap is removed. Next, remove cap from fuel tank.
2. Using a pump-type syphon, drain gasoline into a clean gas can.

Note: There is no other recommended way to drain gasoline from the fuel tank, other than by using a pump-type syphon. An inexpensive syphon can be purchased at a hardware store.

ADJUSTING THROTTLE/CHOKE CONTROL

To assure that choke and carburetor-mounted throttle are operating properly, the throttle control must be adjusted correctly. Hard starting may be an indication of an incorrect adjustment. If throttle control is ever replaced, an adjustment is also necessary. Before the carburetor is adjusted, assure that throttle control is operating properly.

1. Remove the screws holding air cleaner in place and lift complete air cleaner assembly off carburetor (Fig. 16).
2. Move throttle control lever to CHOKE position and check the position of the choke butterfly; it should be fully closed (Fig. 19).
3. Move throttle control lever to FAST position. The butterfly should be in the fully open position (Fig. 19).
4. If the choke butterfly is positioned as described in steps 2 and 3, replace the air cleaner assembly and continue operation.

If either the choke butterfly does not close or is not fully open in the FAST position, adjust the remote control lever as follows.

1. Place remote control lever in FAST position.

MAINTENANCE

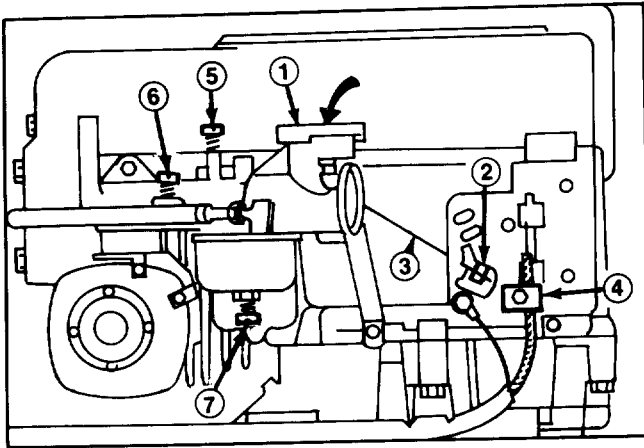

Figure 19

- | | |
|-------------------------|--------------------------|
| 1. Choke Butterfly | 5. Idle Valve |
| 2. Throttle Lever | 6. Idle Speed Adj. Screw |
| 3. Link | 7. Needle Valve |
| 4. Throttle Cable Clamp | |

2. Loosen the throttle cable clamp screw (Fig. 19) and move the control cable casing and wire until the throttle lever touches link.

3. Tighten the cable clamp and assemble the air cleaner assembly to the carburetor.

ADJUSTING CARBURETOR

The carburetor has been set at the factory, but an occasional adjustment may be required. However, do not make unnecessary carburetor adjustments because factory settings are usually correct. An adjustment may be required to compensate for differences in fuel, temperature and altitude.

IMPORTANT: Before the carburetor is adjusted, throttle control must be checked for proper operation: refer to Adjusting Throttle/Choke Control, page 18.

1. Needle Valve (Fig. 19) — Close valve by gently rotating it clockwise.

IMPORTANT: Do not close the needle valve too tight because the valve and seat in carburetor will likely be damaged.

2. Rotate—open—the needle valve 2 turns counterclockwise (Fig. 19).

Note: The needle valve setting is an approximate; however, the setting will allow engine to be started so carburetor can be fine tuned — steps 3-9.

3. Start engine and let it warm up for approximately two minutes. Next, move throttle control into FAST detent.



WARNING

Engine must be running so final adjustment of the carburetor can be performed. To guard against possible personal injury, move blade control into DISENGAGE detent, shift into neutral, and engage parking brake. Keep hands, feet, face, and other parts of the body away from the cutter blade, underside of mower housing and the discharge area.

IMPORTANT: Air cleaner must be installed on the engine whenever high speed is being adjusted. The air cleaner mounting screw must also be installed when engine is run.

4. Rotate needle valve (Fig. 19) clockwise, 1/8 turn at a time, until engine starts to lose speed. Let engine react to each 1/8 turn setting.

5. Rotate needle valve (Fig. 19) counterclockwise — out — 1/8 turn at a time, until engine first runs rough. Let engine react to each 1/8 turn setting.

6. Rotate needle valve (Fig. 19) clockwise—in—very slowly until engine starts to run smoothly. This setting, under no load, may be slightly rich; however, the slightly rich setting will assure proper operation when engine is under load.

7. Move throttle control so engine idles. If engine stalls, rotate idle adjusting screw until engine speed increases (1750 rpm).

Note: Rotate idle adjusting screw clockwise to increase idle rpm. By contrast, rotate idle adjusting screw counterclockwise to decrease idle rpm.

8. Turn idle valve in (lean) and out (rich) slowly until engine idles smoothly.

9. Check carburetor adjustment by quickly moving throttle control from SLOW to FAST. Engine speed should increase without hesitation. If engine tends to stall or die out, rotate needle valve 1/8 turn counterclockwise until engine accelerates smoothly.

10. After carburetor is adjusted, shut engine off. If mower will not be used immediately, remove key from switch to prevent possibility of accidental starting.

SERVICING CUTTER BLADE

1. Make sure engine is shut off and remove wire off spark plug.

IMPORTANT: To remove blade from spindle shaft, the rider must be tipped on its rear end. However,

MAINTENANCE

before the rider is tipped, drain all gasoline from fuel tank and oil from crankcase. Also remove battery so acid does not spill onto the rider. (ALL BAGGING ATTACHMENTS MUST BE REMOVED BEFORE TIPPING RIDER).

2. Drain gasoline from fuel tank: refer to Draining Gasoline From Fuel Tank, page 17.
3. Drain oil from crankcase: refer to Changing Crankcase Oil, steps 1-6, page 15.
4. Remove battery from chassis: refer to Activating and Charging Battery, page 9.
5. Shift transmission into 1st gear and engage parking brake. Tip rider onto its rear end.
6. Grasp end of blade using a rag or thickly padded glove; then remove lock nut, anti-scalp cup and blade (Fig. 20).

Note: Since lock nut is tightened to 45-60 ft-lb (61-81 N·m) at the factory, it may be difficult to remove the nut. If the nut cannot be removed, contact an Authorized TORO Service Dealer or a "service station" for assistance.

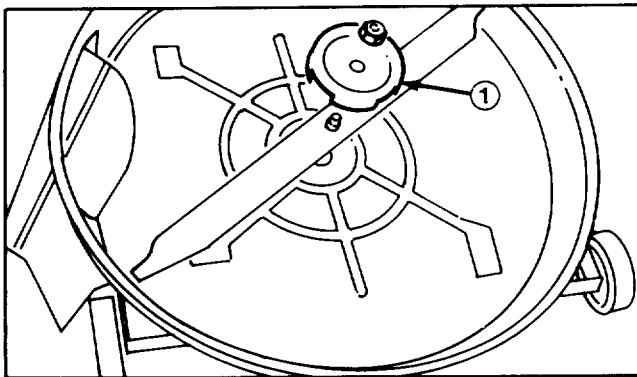

Figure 20

1. Anti-Scalp Cup

7. Using a file, sharpen cutting edge at both ends of the blade (Fig. 21).



CAUTION

Check cutter blade every time rider is tipped on end. If lock nut holding blade is loose, tighten it to 45-60 ft-lb (61-81 N·m). If blade or sabb (Fig. 21) at end of blade is worn, eroded, or cracked, replace the blade. Replace the blade if it is bent or out-of-balance. Always use genuine TORO replacement blades to assure safety and optimum performance. NEVER USE WILL-FIT REPLACEMENT BLADES.

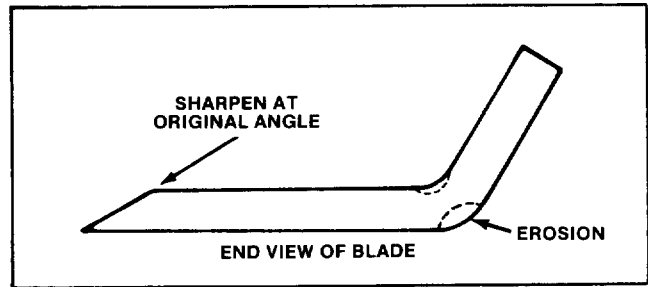

Figure 21

IMPORTANT: Sharpen top side of the blade and maintain original cutting angle to assure a sharp cutting edge. The blade will remain balanced if same amount of material is removed from both cutting edges.

8. Check balance of blade by putting it on a blade balancer. (An inexpensive balancer can be purchased at a hardware store). A balanced blade will stay in a horizontal position on the balancer. By contrast, a blade that is not balanced will settle to the heavy side. If blade is not balanced, file more material off cutting edge of the blade. Continue to file and check the blade until it is balanced.

9. In sequence, install blade, anti-scalp cup and lock nut (Fig. 20). Tighten lock nut to 45-60 ft-lb (61-81 N·m).

IMPORTANT: Make sure cutting edge of blade is away from mower housing. While lock nut is tightened, move blade slightly so it seats between sides of blade retainer.

10. Tip rider back to its normal operating position.
11. Fill crankcase with oil: refer to Check Crankcase Oil Level, page 9.
12. Fill fuel tank with gasoline: refer to Fill Fuel Tank With Gasoline, page 10.
13. Install the battery: refer to Activating and Charging Battery, page 9.

CLEANING UNDERSIDE OF MOWER HOUSING

To assure a good quality-of-cut and efficient grass bagging, underside of mower housing and inside of discharge area must be kept clean. Periodically apply a coat of paste wax on inside of mower housing and grass deflector. This will retard rust and prevent dirt and grass from sticking on inside of housing.

1. Make sure engine is shut off. Then pull wire off spark plug.

MAINTENANCE

IMPORTANT: To clean underside of mower housing, the rider must be tipped on its rear end. However, before the rider is tipped, drain all gasoline from fuel tank and oil from crankcase. Also remove battery so acid does not spill onto the rider. (ALL BAGGING ATTACHMENTS MUST BE REMOVED BEFORE TIPPING RIDER).

2. Drain gasoline from fuel tank: refer to Draining Gasoline From Fuel Tank, page 17.

3. Drain oil from crankcase: refer to Changing Crankcase Oil, steps 1-6, page 15.

4. Remove battery from chassis: refer to Activating and Charging Battery, page 9.

5. Shift transmission into 1st gear and engage the parking brake. Tip rider onto its rear end.

6. Remove grass clippings and dirt sticking to inside of housing by spraying with a garden hose. Scrape out any grass and dirt not removed; then spray housing again.

7. Since rider is tipped on end, check condition of blade (Fig. 21).

8. Tip rider back to its normal operating position.

9. Fill crankcase with oil: refer to Check Crankcase Oil Level, page 9.

10. Fill fuel tank with gasoline: refer to Fill Fuel Tank With Gasoline, page 10.

11. Install the battery: refer to Activating and Charging Battery, page 9.

REMOVING/INSTALLING CUTTING UNIT

1. Lock parking brake and turn front wheels to a full turn position to allow more clearance for cutting unit.

2. Set height-of-cut control to lowest setting and loosen belt guides near engine pulley. Remove belt from engine pulley (Fig. 22).

3. Remove cotter pin from Adjustment Rod and pull from Pivot Tube Arm (Fig. 23).

4. Remove cotterpins from clevis pins on front hanger brackets. Hold front of cutting unit in place with one hand, to prevent falling, and remove clevis pins to lower cutting unit to ground. Pull rear hanger brackets off pins on rear suspension arms. Set height-of-cut control to highest position and slide cutting unit from under Rider (Fig. 24).

5. Install in reverse order.

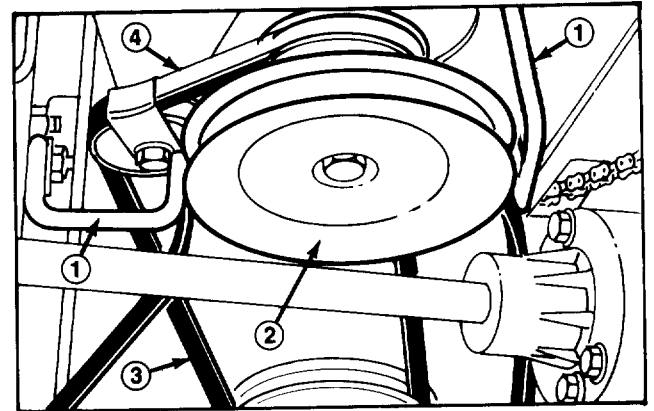

Figure 22

1. Belt Guides
2. Engine Pulley
3. Blade Drive Belt
4. Traction Drive Belt

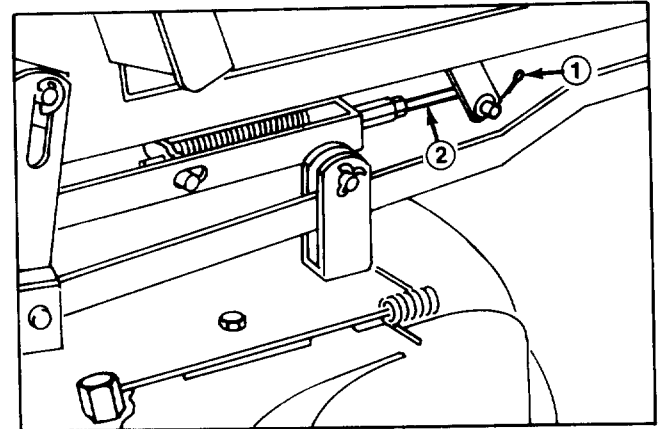

Figure 23

1. Cotter Pin
2. Adjustment Rod

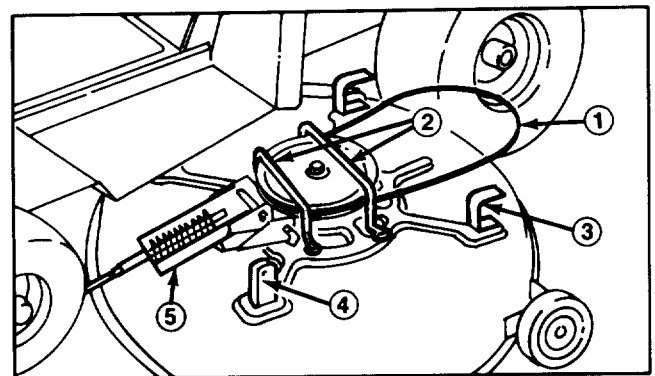

Figure 24

1. Drive Belt
2. Belt Guide
3. Rear Hanger Bracket
4. Front Hanger Bracket
5. Brake Engagement Bracket

REPLACING BLADE DRIVE BELT

1. Lock parking brake and remove high tension lead from spark plug.

MAINTENANCE

2. Remove cutting unit: refer to Removing Cutting Unit, page 20.

3. Loosen and remove (1) mounting screw securing each belt guide to cutting unit. Pivot belt guides away from spindle pulley and remove belt. Visually inspect belt for wear or damage (Fig. 24).

4. Install new belt if needed and reinstall belt guide.

5. Install cutting unit: refer to Installing Cutting Unit, page 20.

ADJUSTING BLADE DRIVE BELT

1. Set height-of-cut lever in lowest setting and deck engagement lever to 'Engage'.

2. Loosen jam nut and turn adjusting hub until there is 0.060 inch (1.5 mm) or less between end of slot in engagement bracket and outer diameter of pin. Retighten jam nut at new hub setting (Fig. 25).

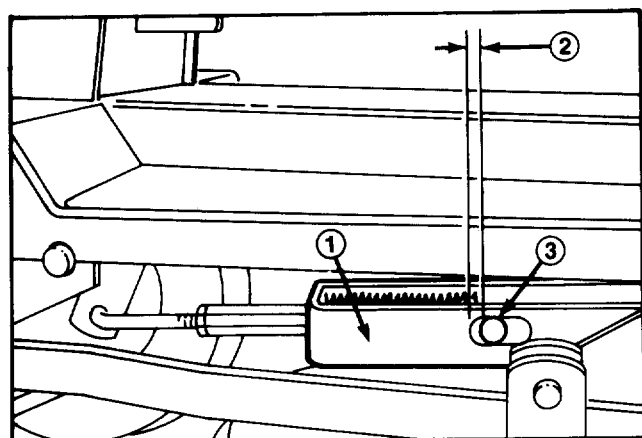

Figure 25

1. Engagement Bracket
2. 0.060 Inch Max. (1.5 mm)
3. Pin

REPLACING TRACTION DRIVE BELT

1. Remove cutting unit: refer to Removing/Installing Cutting Unit, page 20.

2. Remove belt guides from transmission pulley and loosen belt guides at engine pulley. Loosen locknut and remove belt retainer from idler pulley.

3. Pull idler arm to release belt tension and remove drive belt. Inspect belt for damage or wear and install new belt if needed.

4. Replace belt guides for transmission pulley and retighten belt guides on engine pulley. Install belt retainer on idler pulley positioned toward rear as shown (Fig. 23 & 24).

5. Reinstall cutting unit: refer to Removing/Installing Cutting Unit page 20.

IMPORTANT: Belt retainer must be installed toward rear per step 4 or rider may creep forward in neutral.

ADJUSTING DRIVE CHAIN

The drive chain must be adjusted to maintain 1/8 of an inch deflection at mid span between transmission and differential sprockets. Check chain deflection after the first 5 hours of operation and after every 25 hours of operation, thereafter.

IMPORTANT: If chain is worn, loose or adjusted incorrectly, chain could come off sprockets, resulting in no brakes or traction drive. If assistance is needed, contact your local authorized Toro Dealer.

1. Check deflection of drive chain by lifting up on chain with moderate pressure at mid span (Fig. 26). There should be 1/8 of an inch (3 mm) deflection (Fig. 26). If deflection is not as specified, an adjustment is required — steps 2-13.

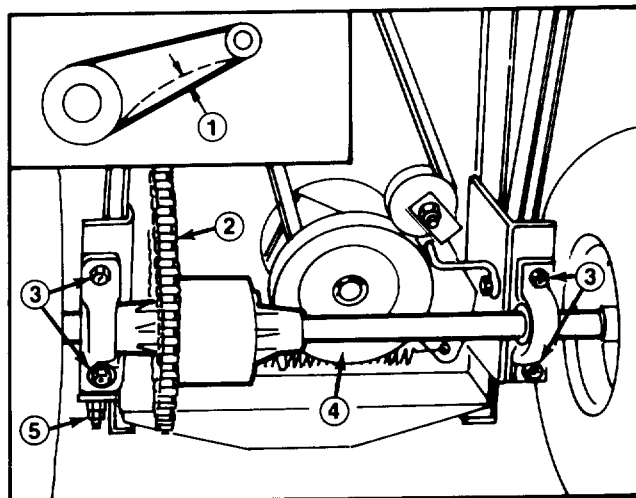

Figure 26

1. .12 Inch (3.0 mm)
2. Drive Chain
3. Locknuts
4. Differential Axle
5. Chain Tensioner

IMPORTANT: To adjust drive chain, the rider must be tipped on its rear end or rear tires raised off ground. However, before the rider is tipped, drain all gasoline from fuel tank and oil from crankcase. Also remove the battery so acid does not spill onto the rider. (ALL BAGGING ATTACHMENTS MUST BE REMOVED BEFORE TIPPING RIDER).

2. Drain gasoline from fuel tank: refer to Draining Gasoline From Fuel Tank, page 17.

3. Drain oil from crankcase: refer to Changing Crankcase Oil, page 15.

4. Remove battery from chassis: refer to Activating and Charging Battery, page 9.

MAINTENANCE

5. Shift transmission into 1st gear and engage the parking brake. Tip rider onto its rear end so chassis is on top of 2" x 4" blocks (Fig. 26). Wheels must be off the floor so axle can be moved.

6. Loosen four flange nuts securing pillow blocks w/ differential axle to the rider frame (Fig. 26).

7. Loosen rear jamnut on chain tensioner (Fig. 26).

8. Rotate inside nut on chain tensioner until desired chain deflection is attained.

9. Tighten flange nuts securing right pillow block (chain side) to rider frame.

10. Since differential axle must be parallel to rear of chassis, measure distance from center of pillow blocks to rear of chassis (Fig. 26). Difference between the two measurements must not exceed 1/4 inch (6 mm). If difference exceeds 1/4 inch (6 mm), differential axle is not parallel with chassis; therefore left side must be repositioned to attain desired dimension. Tighten locknuts securing left pillow block to rider frame.

11. Check the deflection of the drive chain from bottom of rider.

12. Tip rider back to its normal operating position.

13. Fill crankcase with oil; refer to Check Crankcase Oil Level, page 9.

14. Fill fuel tank with gasoline; refer to Fill Fuel Tank With Gasoline, page 10.

15. Install the battery; refer to Activating and Charging Battery, page 9.

ADJUSTING FRONT WHEEL ALIGNMENT

IMPORTANT: To align front wheels, the rider must be tipped on its rear end. However, before the rider is tipped, drain all gasoline from fuel tank and oil from crankcase. Also remove battery so acid does not spill onto the rider.

1. Drain gasoline from fuel tank: refer to Draining Gasoline From Fuel Tank, page 17.

2. Drain oil from crankcase: refer to Changing Crankcase Oil, steps 1-6 page 15.

3. Remove battery from chassis: refer to Activating and Charging Battery, page 9.

4. Shift transmission into 1st gear and engage parking brake.

5. Tip rider up and onto its rear end.

6. Insure rear axle is adjusted properly: refer to step 10 of Adjusting Drive Chain page 21.

7. To align front wheels, loosen jamnut and turn tie rods until centerline distance across front of wheels is .06 inch (1.5 mm) to .25 inch (6.3 mm) less than centerline distance across rear of front wheels (Fig. 27).

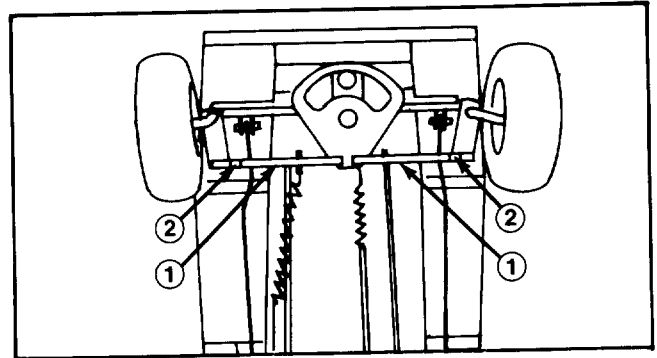

Figure 27

1. Tie Rod

2. Jam Nut

8. Retighten jamnuts and tip rider back to its normal operating position.

9. Fill crankcase with oil: refer to Check Crankcase Oil Level, page 9.

10. Fill fuel tank with gasoline: refer to Fill Fuel Tank With Gasoline, page 10.

11. Install the battery: refer to Activating and Charging Battery, page 9.

ADJUSTING BRAKE

Adjust brake pucks if the parking brake does not hold or braking power is not sufficient when brake pedal is depressed.

1. Shut engine off and remove wire from spark plug.

2. Tighten locknut approximately 1/4 turn clockwise (Fig. 28).

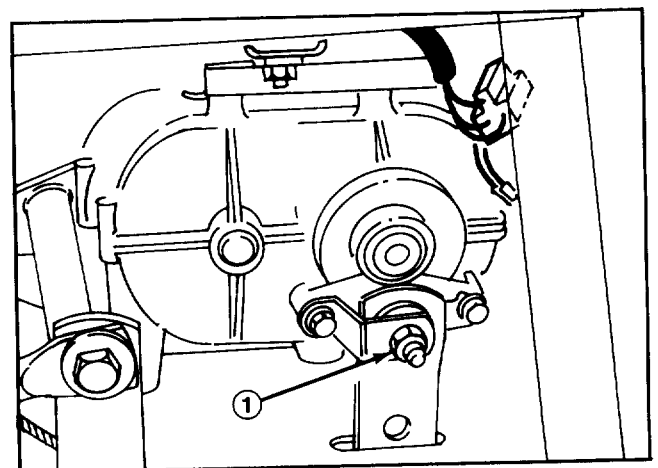

Figure 28

1. Locknut

MAINTENANCE

3. Check operation of the brake by pushing rider: no brake drag should be evident. If drag is evident, rotate locknut an additional 1/8 turn counter-clockwise or until there is no contact.

LEVELING CUTTING UNIT

If mower doesn't cut level from side to side and cutting blade is not bent, level the cutting unit as follows:

1. Place rider on level surface, lock parking brake, shut off engine and remove key from ignition switch.
2. Place height-of-cut lever in number 3 position and position cutter blade at a right angle to direction of rider travel.
3. Measure the blade tip height at one end of blade, rotate blade 180° and measure same blade tip at opposite side of rider. Measurement should be within 1/8 inch (3mm) of one another.

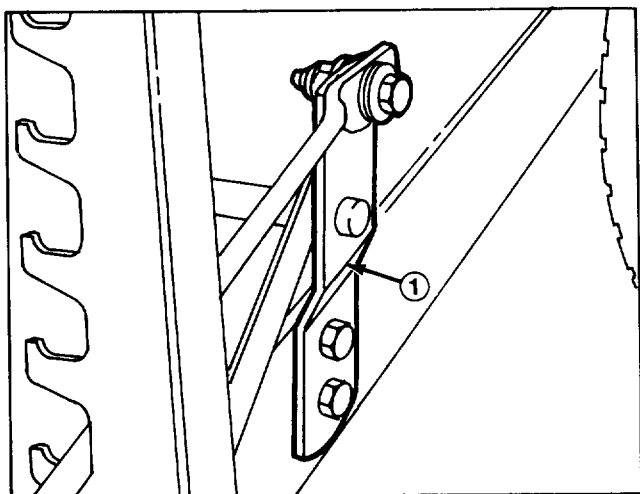

Figure 29

1. Height-of-Cut Support Bracket

4. If blade tip height is not within 1/8 inch (3 mm), level cutting unit by loosening height-of-cut support bracket capscrews and raising or lowering the bracket (Fig. 29).
5. Assure blade tip height is within 1/8 inch (3 mm) and retighten capscrews.

ADJUSTING GEAR SHIFT NEUTRAL POSITION

An adjustment to the gear shift guide may be required if gear shift will not go into neutral position.

1. Loosen (2) capscrews mounting gear shift guide to transmission (Fig. 30).
2. Move guide so neutral position aligns with gear shift lever when in neutral position.

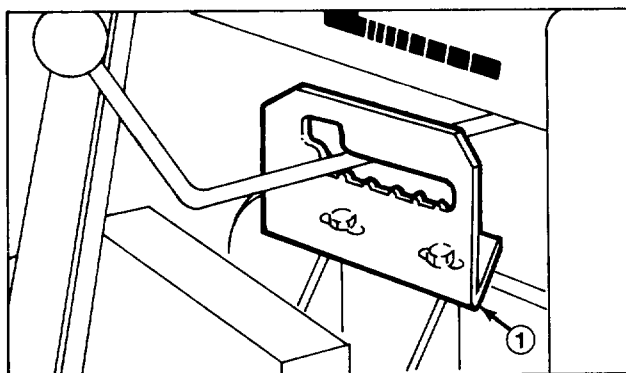

Figure 30

1. Gear Shift Guide

3. Tighten capscrews.

CHECKING ELECTRICAL CONNECTIONS

1. Make sure wires on starter motor terminal and battery terminals are secured tightly.
2. Make sure two wires are connected to transmission interlock switch.
3. Push module connectors together to assure connection (Fig. 31).
4. Also check wires that connect to ignition switch to assure good contact.
5. Check wires to interlock switch on deck engagement lever support for good contact.
6. Check the interlock switch inside front of the seat base to be making good contact. Also, assure seat switch connectors are together and wires are making good contact.

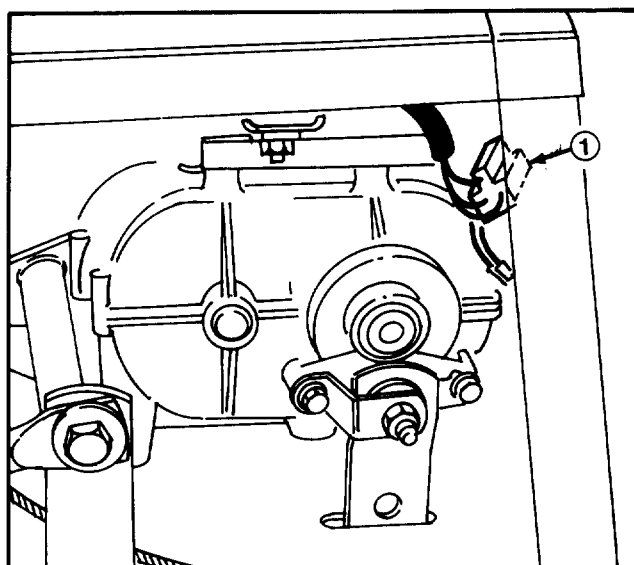

Figure 31

1. Connectors

MAINTENANCE

CHECKING SAFETY INTERLOCK SYSTEM

The interlock switches in the electrical system prevent the engine from starting unless the gear shift is in neutral and deck engagement lever is disengaged. In addition, the engine will stop — because of a seat switch — if the operator gets off the seat when deck engagement lever is engaged or gear shift is in gear. To assure interlock system is operating correctly, check it before each use of the rider. Have the system checked by an Authorized TORO Service Dealer every two years to assure safe operation of the rider.

1. Check all electrical connections: refer to Checking Electrical Connections, page 23.
2. Move gear shift into neutral.
3. Move deck engagement lever into ENGAGE. Sit on the seat and rotate ignition key to START. Engine should not start; but if it does, the interlock system is malfunctioning and it must be repaired by an Authorized TORO Service Dealer. If engine does not start, proceed to step 4.
4. Move deck engagement lever into DISENGAGE. Sit on the seat, depress the brake and clutch pedals, engage the parking brake and shift into gear. Rotate ignition key to START. Engine should not start; but if it does, the interlock system is malfunctioning and must be repaired by an Authorized TORO Service Dealer. If engine does not start, proceed to step 5.
5. Sit on the seat, move gear shift into neutral, deck engagement lever into DISENGAGE and assure parking brake is engaged. Rotate ignition key to START. Engine should start and continue to run. Then engage deck engagement lever and carefully raise off the seat: the engine should stop. If engine does not stop running, shut engine off and have interlock system repaired by an Authorized TORO Service Dealer. If engine shuts off when you raised off the seat, the interlock system is functioning correctly and the rider can be operated safely.

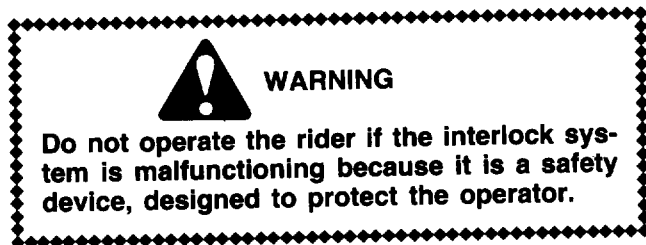

PREPARING MOWER FOR STORAGE

1. Drain gasoline from fuel tank and fuel line: refer to Draining Gasoline From Fuel Tank, page 17. Next, start engine and let it run at idle speed until it stops because all gasoline is used.

Note: All gasoline must be expended to prevent gum-like varnish deposits from forming in the carburetor, fuel line, and fuel tank. Such deposits, if allowed to form, will cause starting problems and poor engine operation.

2. Remove wire from spark plug and clean area around the plug so foreign matter cannot fall into cylinder when plug is removed. Next, remove plug from cylinder head and pour two tablespoons of engine oil into spark plug hole. Rotate engine by hand to distribute oil on inside of cylinder. Then reinstall spark plug and tighten it to 15 ft-lb (20.4 N-m) If torque wrench is not used, tighten plug firmly. **DO NOT INSTALL WIRE ON SPARK PLUG.**
 3. Drain oil from crankcase: refer to Changing Crankcase Oil, page 15. However, do not fill crankcase with oil at this time.
 4. Remove battery from chassis: refer to Activating and Charging Battery, page 9. Remove corrosion from battery terminal and wipe any grease and dirt off the battery case. Check level of electrolyte. If level is low, add drinkable water to the affected cell. Fill only to the fill ring below the filler cap. Reinstall filler caps.
 5. Clean dirt and chaff from outside of cylinder, cylinder head fins, and blower housing. Also, remove grass clippings, dirt, and grime from external parts of rider, engine, shrouding, and top of mower housing.
 6. Clean underside of mower housing: refer to Cleaning Underside of Mower Housing, page 19.
 7. Check condition of blade: refer to Servicing Cutter Blade, page 18.
 8. Check and tighten all cap screws, bolts, screws, nuts, and mating parts. If any part is damaged, repair or replace it.
 9. Lubricate wheels and spindles with grease: refer to Grease Front Axle Spindles and Wheels, page 14.
 10. Remove dust and dirt from air cleaner element: refer to Servicing Air Cleaner, page 16.
 11. Touch up all rusted or chipped paint surfaces. Make sure to sand affected area before painting.
- Note:** TORO Re-Kote “touch-up” paint is available from any Authorized TORO Service Dealer. The spray paint dries in minutes to a glossy, factory-finish.
12. Fill crankcase with oil: refer to Check Crankcase Oil Level, page 9.

MAINTENANCE

13. Install the battery: refer to Activating and Charging Battery, page 9. Charge battery for 48 hours to assure full charge.

14. Store the rider in a clean, dry garage or storage area. Remove key from ignition switch and keep it in a memorable place. Cover the rider to protect it and keep it clean.

WIRING DIAGRAM

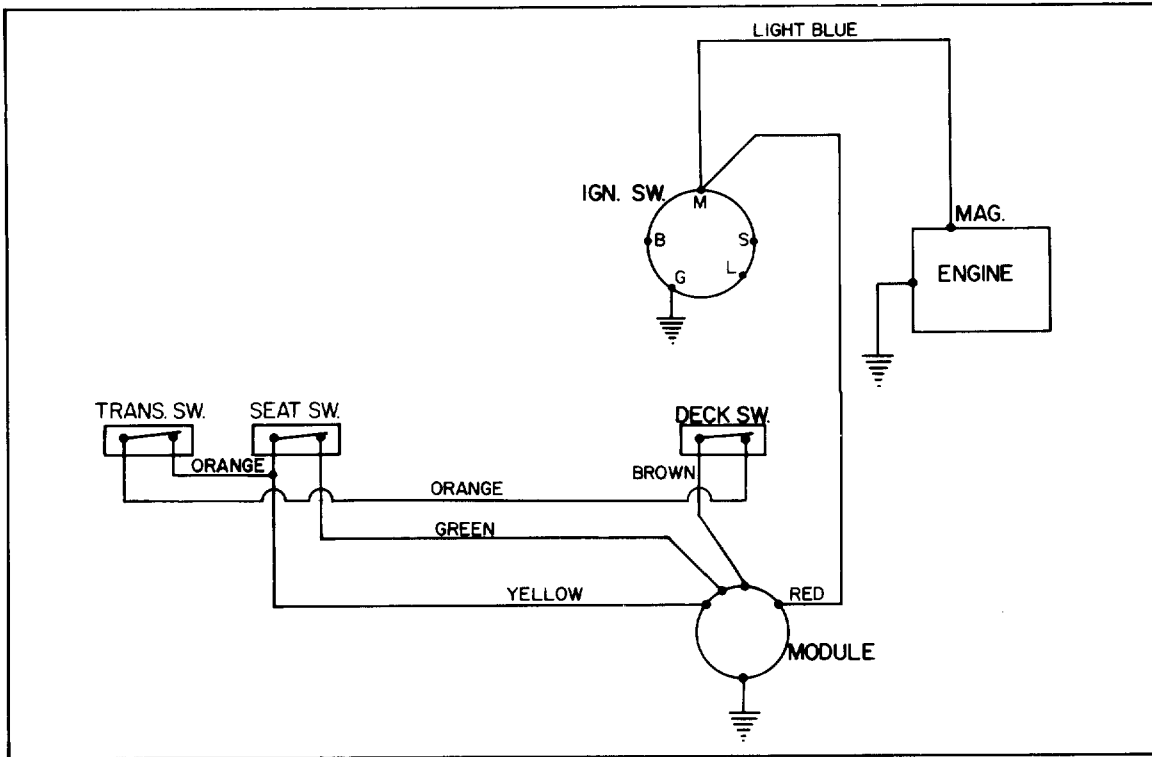

832 Recoil Rider

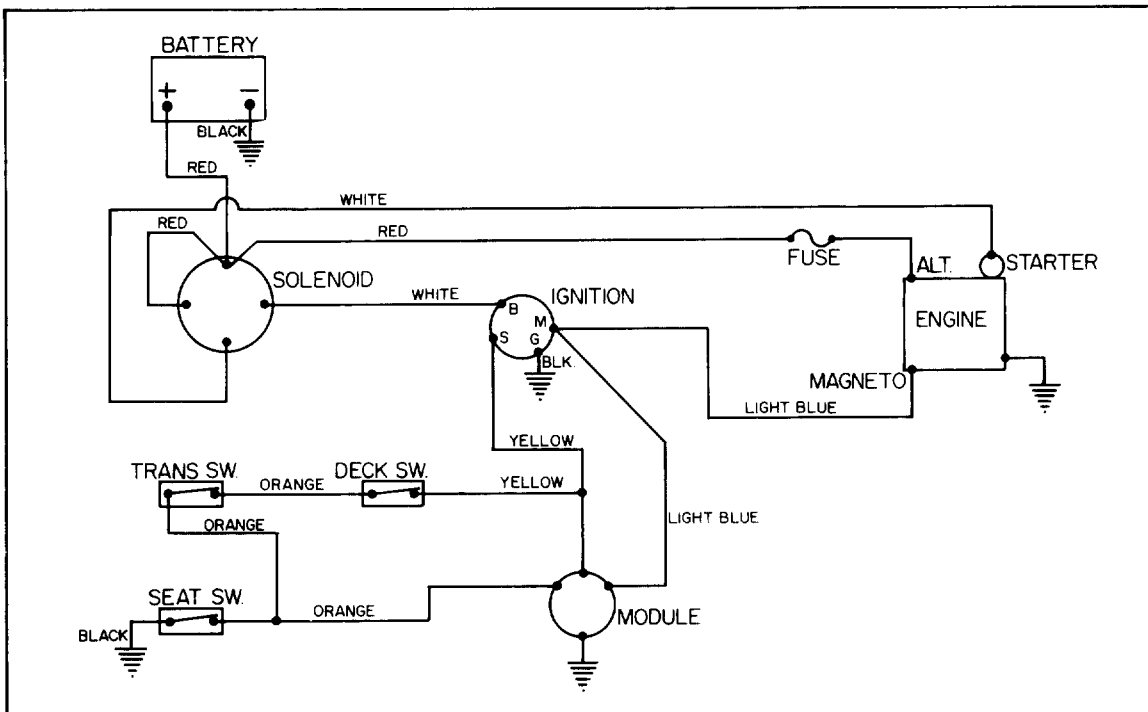

832 Electric Start Rider

TROUBLE SHOOTING

Problem	Possible Causes	Corrective Action
<p>Engine does not start, starts hard, loses power, or fails to keep running.</p>	<ol style="list-style-type: none"> 1. Gas tank is empty. 2. Battery is dead. 3. Transmission is in gear. 4. Deck engagement lever is in ENGAGE. 5. Spark plug is loose. 6. Wire is loose or disconnected from spark plug. 7. Spark plug gap is incorrect. 8. Spark plug is pitted, fouled, or defective in some other way. 9. Wrong spark plug is used. 10. Electrical connections are loose. 11. Carburetor is adjusted incorrectly. 12. Air cleaner is dirty. 13. Vent hole in fuel tank cap is plugged. 14. Dirt, water, or stale fuel in fuel system. 15. Module or switch is defective. 	<ol style="list-style-type: none"> 1. Fill fuel tank with gasoline. 2. Charge the battery. 3. Shift transmission into neutral. 4. Move deck engagement lever into DISENGAGE. 5. Tighten plug to 15 ft-lb (20.4 N·m). 6. Install wire on spark plug. 7. Set gap between electrodes at 0.030 of an inch (0.76 mm). 8. Install new, correctly gapped spark plug. 9. Install correct spark plug. 10. Check electrical system to assure good contact. 11. Adjust the carburetor. 12. Clean the air cleaner element. 13. Clean or replace fuel cap. 14. Have rider serviced by Authorized TORO Service Dealer. 15. Have rider serviced by Authorized TORO Service Dealer.
<p>Engine does not idle or idles poorly.</p>	<ol style="list-style-type: none"> 1. Air cleaner is dirty. 2. Oil level in crankcase is low. 3. Cooling fins and air passages under engine blower housing are plugged. 4. Idle speed is too low or high speed mixture is incorrect. 5. Dirt, water, or stale fuel is in fuel system. 6. Vent hole in fuel tank cap is plugged. 7. Spark plug is pitted, fouled or defective in some other way. 	<ol style="list-style-type: none"> 1. Clean air cleaner element. 2. Add oil to crankcase. 3. Remove obstruction from cooling fins and air passages. 4. Adjust the carburetor. 5. Have rider serviced by Authorized TORO Service Dealer. 6. Clean or replace fuel tank cap. 7. Install new correctly gapped spark plug.

TROUBLE SHOOTING

Problem	Possible Causes	Corrective Action
Engine loses power	<ol style="list-style-type: none"> 1. Oil level in crankcase is low. 2. Cooling fins and air passages under engine blower housing are plugged. 3. Engine load is excessive. 4. Air cleaner is dirty. 5. Dirt, water, or stale fuel is in fuel system. 6. Carburetor is adjusted incorrectly. 7. Spark plug is pitted, fouled or defective in some other way. 	<ol style="list-style-type: none"> 1. Add oil to crankcase. 2. Remove obstruction from cooling fins and air passages. 3. Shift into lower gear to reduce load. 4. Clean air cleaner element. 5. Have rider serviced by Authorized TORO Service Dealer. 6. Adjust the carburetor. 7. Install new correctly gapped spark plug.
Engine over heats	<ol style="list-style-type: none"> 1. Cooling fins and air passages under engine blower housing are plugged. 2. Carburetor is adjusted incorrectly. 3. Oil level in crankcase is low. 4. Engine load is excessive. 	<ol style="list-style-type: none"> 1. Remove obstruction from cooling fins and air passages. 2. Adjust the carburetor. 3. Add oil to crankcase. 4. Shift into lower gear to reduce load.
Rider vibrates abnormally	<ol style="list-style-type: none"> 1. Engine mounting bolts are loose. 2. Differential axle is misaligned. 3. Loose PTO pulley, idler pulley or blade pulley. 4. Cutter blade is unbalanced. 5. Lock nut holding blade is loose. 6. Drive pulley is damaged. 	<ol style="list-style-type: none"> 1. Tighten engine mounting bolts. 2. Adjust the drive chain, which includes the differential axle. 3. Tighten the appropriate pulley. 4. Install new cutter blade. 5. Tighten nut to 45-60 ft-lb (61-81 N-m). 6. Replace drive pulley.
Blade does not rotate	<ol style="list-style-type: none"> 1. Blade drive belt is worn, loose or broken. 2. Blade drive belt is off pulley. 	<ol style="list-style-type: none"> 1. Install new blade drive belt. 2. Install blade drive belt and check idler pulley and belt guides for correct position.
Rider does not drive	<ol style="list-style-type: none"> 1. Traction belt is worn, loose or broken. 2. Traction drive belt is off pulley. 3. Drive chain is off sprockets. 4. Transmission does not shift gear. 5. Traction idler is adjusted incorrectly. 	<ol style="list-style-type: none"> 1. Install new traction drive belt. 2. Install traction drive belt. 3. Install and adjust drive chain. 4. Have rider serviced by Authorized TORO Service Dealer. 5. Adjust traction drive belt.

PRODUCT IDENTIFICATION

A model and serial decal is located on top left side of engine plate, near the spark plug. Always refer to specific numbers on this decal in correspondence or when replacement parts are needed.

The Toro Promise

*A Two Year Limited Warranty
On All
Gasoline Powered Consumer Products*

The Toro Company promises to repair these TORO Products if defective in materials or workmanship. The following time periods from the date of purchase apply:

Residential Product 2 Years
Residential Products Used Commercially . . . 45 Days

The costs of parts and labor are included, but the customer pays the transportation costs. Just return any residential product to an Authorized TORO Service Dealer or TORO Distributor.

Should you feel your TORO is defective and wish to rely on The Toro Promise, the following procedure is recommended:

1. Contact any Authorized TORO Service Dealer, TORO Master Service Dealer, or TORO Distributor (the Yellow Pages of your telephone directory is a good reference source).
2. He will either instruct you to return the product to him or recommend another Authorized TORO Service outlet which might be more convenient.
3. Bring the product along with your original sales slip, or other evidence of purchase date, to the service dealer.
4. The servicing dealer will inspect the unit, advise you whether the product is defective and, if so, make all repairs necessary to correct the defect without extra charge to you.

If for any reason you are dissatisfied with the dealer's analysis of the defect or the service performed, you may contact us.

Write:

**TORO Customer Service Department
8111 Lyndale Avenue South
Minneapolis, Minnesota 55420**

The above remedy of product defects through repair by an Authorized TORO Service Dealer is the purchaser's sole remedy for any defect.

THERE IS NO OTHER EXPRESS WARRANTY. ALL IMPLIED WARRANTIES OF MERCHANTABILITY AND

FITNESS FOR USE ARE LIMITED TO THE DURATION OF THE EXPRESS WARRANTY.

Some states do not allow limitation on how long implied warranty lasts, so the above limitation may not apply to you.

This Warranty applies only to parts or components which are defective and does not cover repairs necessary due to normal wear, misuse, accidents, or lack of proper maintenance. Regular, routine maintenance of the unit to keep it in proper operating condition is the responsibility of the owner.

All warranty repairs reimbursable under The Toro Promise must be performed by an Authorized TORO Service Dealer using Toro approved replacement parts.

Repairs or attempted repairs by anyone other than an Authorized TORO Service Account are not reimbursable under The Toro Promise. In addition, these unauthorized repair attempts may result in additional malfunctions, the correction of which is not covered by warranty.

The Toro Company is not liable for indirect, incidental or consequential damages in connection with the use of the product including any cost or expense of providing substitute equipment or service during periods of malfunction or non-use.

Some states do not allow the exclusion of incidental or consequential damages, so the above exclusion may not apply to you.

This warranty gives you specific legal rights, and you may also have other rights which vary from state to state.