



76cm TurfMaster Walk-Behind Lawn Mower

Model No. 22205TE—Serial No. 314000001 and Up

Form No. 3381-352 Rev A

Operator's Manual

Introduction

This rotary-blade, walk-behind lawn mower is intended to be used by residential homeowners or professional, hired operators. It is designed primarily for cutting grass on well-maintained lawns on residential or commercial properties. It is not designed for cutting brush or for agricultural uses.

Read this information carefully to learn how to operate and maintain your machine properly and to avoid injury and equipment damage. You are responsible for operating the machine properly and safely.

You may contact Toro directly at www.Toro.com for product and accessory information, help finding a dealer, or to register your product.

Whenever you need service, genuine Toro parts, or additional information, contact an Authorized Service Dealer or Toro Customer Service and have the model and serial numbers of your machine ready. Figure 1 identifies the location of the model and serial numbers on the product. Write the numbers in the space provided.

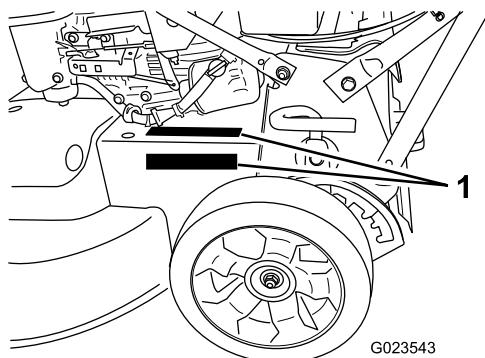

Figure 1

1. The model and serial number plate is in either of these 2 locations.

Model No. _____
Serial No. _____

This manual identifies potential hazards and has safety messages identified by the safety alert symbol (Figure 2), which signals a hazard that may cause serious injury or death if you do not follow the recommended precautions.



Figure 2

1. Safety alert symbol

This manual uses 2 words to highlight information.

Important calls attention to special mechanical information and **Note** emphasizes general information worthy of special attention.

Net Torque

The gross or net torque of this engine was laboratory rated by the engine manufacturer in accordance with the Society of Automotive Engineers (SAE) J1940. As configured to meet safety, emission, and operating requirements, the actual engine torque on this class of mower will be significantly lower.

This product complies with all relevant European directives. For details, see the separate product-specific Declaration of Conformity (DOC) sheet.

Contents

Introduction	1
General Lawn Mower Safety	2
Sound Pressure	3
Sound Power	3
Hand/Arm Vibration	3
Safety and Instructional Decals	4
Setup	6
1 Installing the Handle	6
2 Filling the Crankcase with Oil	6
Product Overview	8
Controls	8
Operation	9
Checking the Engine Oil Level	9
Filling the Fuel Tank with Gasoline	9
Adjusting the Cutting Height.....	10
Starting the Engine	11
Stopping the Engine	11
Operating the Self-propel Drive and Engaging the Cutting Blades.....	12
Checking the Blade-stop System Operation	12
Recycling the Clippings	13
Bagging the Clippings	13
Side-discharging the Clippings.....	14
Operating Tips	15
Maintenance	16



Recommended Maintenance Schedule(s)	16
Servicing the Air Filter	17
Changing the Engine Oil	17
Changing the Oil Filter	18
Servicing the Spark Plug	18
Checking the Condition of the Belts	19
Emptying the Fuel Tank and Cleaning the Filter	19
Changing the Fuel Filter	19
Servicing the Blade-drive System	19
Servicing the Cutting Blades.....	20
Changing the Blade-Brake-Clutch (BBC) Belt.....	22
Adjusting the Self-propel Cable	23
Adjusting the Blade-brake Cable	23
Changing the Blade-drive Belt	24
Cleaning under the Machine Housing	24
Storage	25
General Information.....	25
Preparing the Fuel System	25
Preparing the Engine	26
Removing the Machine from Storage.....	26
Troubleshooting	27

Safety

Improperly using or maintaining this machine can result in injury. To reduce the potential for injury, comply with these safety instructions.

Toro designed and tested this machine for reasonably safe service; however, failure to comply with the following instructions may result in personal injury.

To ensure maximum safety, best performance, and to gain knowledge of the product, it is essential that you and any other operator of the mower read and understand the contents of this manual before the engine is ever started. Pay particular attention to the safety alert symbol (Figure 2), which means Caution, Warning, or Danger—“personal safety instruction.” Read and understand the instruction because it has to do with safety. Failure to comply with the instruction may result in personal injury.

General Lawn Mower Safety

The following instructions have been adapted from EN 836.

This cutting machine is capable of amputating hands and feet and of throwing objects. Failure to observe the following safety instructions could result in serious injury or death.

Training

- Read the instructions carefully. Be familiar with the controls and the proper use of the equipment.

- Never allow children or people unfamiliar with these instructions to use the mower. Local regulations can restrict the age of the operator.
- Keep in mind that the operator or user is responsible for accidents or hazards occurring to other people or their property.
- Understand explanations for all pictograms used on the mower or in the instructions.

Gasoline

WARNING! Gasoline is highly flammable. Take the following precautions.

- Store fuel in containers specifically designed for this purpose.
- Refuel outdoors only and do not smoke while refueling.
- Add fuel before starting the engine. Never remove the cap of the fuel tank or add gasoline while the engine is running or when the engine is hot.
- If gasoline is spilled, do not attempt to start the engine but move the mower away from the area of spillage and avoid creating any source of ignition until gasoline vapors have dissipated.
- Replace all fuel tank and container caps securely.

Preparation

- While mowing, always wear substantial footwear and long trousers. Do not operate the equipment when barefoot or wearing open sandals.
- Thoroughly inspect the area where the equipment is to be used and remove all stones, sticks, wires, bones, and other foreign objects.
- Before using, always visually inspect to see that guards, and safety devices, such as deflectors and/or grass catchers, are in place and working correctly.
- Before using, always visually inspect to see that the blades, blade bolts, and cutter assembly are not worn or damaged. Replace worn or damaged blades and bolts in sets to preserve balance.

Starting

- Disengage all blade and drive clutches, and shift into neutral before starting the engine.
- Do not tilt the mower when starting the engine unless the mower has to be tilted for starting. In this case, do not tilt it more than absolutely necessary, and lift only the part which is away from the operator.
- Start the engine carefully according to instructions and with feet well away from the blade(s) and not in front of the discharge chute.

Operation

- Never mow while people, especially children, or pets are nearby.

- Mow only in daylight or in good artificial light.
- Stay alert for holes in the terrain and other hidden hazards.
- Do not put hands or feet near or under rotating parts. Keep clear of the discharge opening at all times.
- Never pick up or carry a lawn mower while the engine is running.
- Use extreme caution when reversing or pulling a pedestrian-controlled lawn mower toward you.
- Walk, never run.
- Slopes:
 - Do not mow excessively steep slopes.
 - Exercise extreme caution when on slopes.
 - Mow across the face of slopes, never up and down, and exercise extreme caution when changing direction on slopes.
 - Always be sure of your footing on slopes.
- Reduce speed on slopes and in sharp turns to prevent overturning or loss of control.
- Stop the blade if the machine has to be tilted for transportation when crossing surfaces other than grass and when transporting the machine to and from the area to be mowed.
- Do not operate the engine in a confined space where dangerous carbon monoxide fumes can collect.
- Stop the engine
 - whenever you leave the machine.
 - before refueling.
 - before removing the grass catcher.
 - before making height adjustment unless adjustment can be made from the operator's position.
- Stop the engine and disconnect the spark-plug wire
 - before clearing blockages or unclogging chute.
 - before checking, cleaning or working on the machine.
 - after striking a foreign object, inspect the lawn mower for damage and make repairs before starting and operating the lawn mower.
 - if lawn mower starts to vibrate abnormally (check immediately).
- Lightning can cause severe injury or death. If you see lightning or hear thunder in the area, do not operate the machine; seek shelter.
- Watch out for traffic when crossing or near roadways.
- Never store the equipment with gasoline in the tank and inside a building where fumes can reach an open flame or spark.
- Allow the engine to cool before storing in any enclosure.
- To reduce the fire hazard, keep the engine, silencer, battery compartment and gasoline storage area free of grass, leaves, or excessive grease.
- Check the grass catcher components and the discharge guard frequently, and replace them with manufacturer's recommended parts, when necessary.
- Replace worn or damaged parts for safety.
- Replace faulty silencers.
- If the fuel tank has to be drained, do this outdoors.
- Do not change the engine governor settings or overspeed the engine. Operating an engine at excessive speed can increase the hazard of personal injury.
- Be careful during adjustment of the machine to prevent entrapment of the fingers between moving blades and fixed parts of the machine.
- **To best protect your investment and maintain optimal performance of your Toro equipment, count on Toro genuine parts. When it comes to reliability, Toro delivers replacement parts designed to the exact engineering specifications of our equipment. For peace of mind, insist on Toro genuine parts.**

Sound Pressure

This unit has a sound pressure level at the operator's ear of 89 dBA, which includes an Uncertainty Value (K) of 1 dBA.

The sound pressure level was determined according to the procedures outlined in EN 836.

Sound Power

This unit has a guaranteed sound power level of 100 dBA, which includes an Uncertainty Value (K) of 1 dBA.

The sound power level was determined according to the procedures outlined in ISO 11094.

Hand/Arm Vibration

Measured vibration level for right hand = 2.0 m/s

Measured vibration level for left hand = 4.5 m/s

Uncertainty Value (K) = 2.2 m/s²

Measured values were determined according to the procedures outlined in EN 836.

Maintenance and Storage

- Keep all nuts, bolts, and screws tight to be sure that the equipment is in safe working condition.
- Do not use pressure-cleaning equipment on machine.

Safety and Instructional Decals

Important: Safety and instruction decals are located near areas of potential danger. Replace damaged decals.

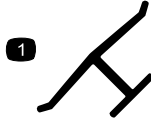

Manufacturer's Mark

1. Indicates the blade is identified as a part from the original machine manufacturer.

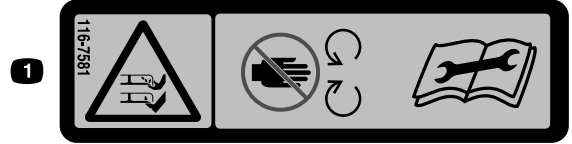

116-7581

1. Cutting/dismemberment hazard of hand or foot, mower blade—stay away from moving parts. Read the *Operator's Manual* before adjusting servicing, or cleaning.



93-7009

1. Warning—do not operate the mower with the deflector up or removed; keep the deflector in place.
2. Cutting/dismemberment hazard of hand or foot, mower blade—stay away from moving parts.

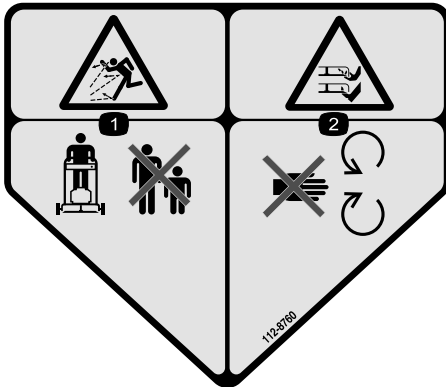

112-8760

1. Thrown object hazard—keep bystanders a safe distance from the machine.
2. Cutting/dismemberment of hand or foot—stay away from moving parts.

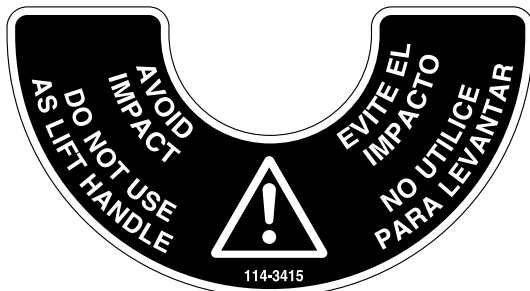

114-3415



116-7583

- | | |
|--|--|
| <ol style="list-style-type: none"> 1. Warning—Read the Operator's Manual. Do not operate this machine unless you are trained. 2. Thrown object hazard—keep bystanders a safe distance from the machine. 3. Thrown object hazard—Do not operate the mower without the rear discharge plug or bag in place. | <ol style="list-style-type: none"> 4. Cutting/dismemberment hazard of hand or foot, mower blade—stay away from moving parts; keep all guards in place. 5. Warning—wear hearing protection. 6. Cutting/dismemberment hazard of hand or foot, mower blade—Do not operate up and down slopes; operate side to side on slopes; stop the engine before leaving the operating position—pick up objects that could be thrown by the blades; and look behind you when backing up. |
|--|--|

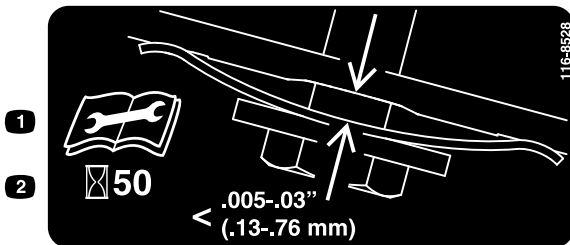

116-8528

- | | |
|---|---|
| <ol style="list-style-type: none"> 1. Read the <i>Operator's Manual</i> before performing any maintenance. | <ol style="list-style-type: none"> 2. Check belt tension every 50 hours. |
|---|---|



116-9313

- | | |
|---|---|
| <ol style="list-style-type: none"> 1. Read the <i>Operator's Manual</i>. 2. Fire hazard | <ol style="list-style-type: none"> 3. Toxic gas inhalation hazard 4. Hot surface; burn hazard |
|---|---|

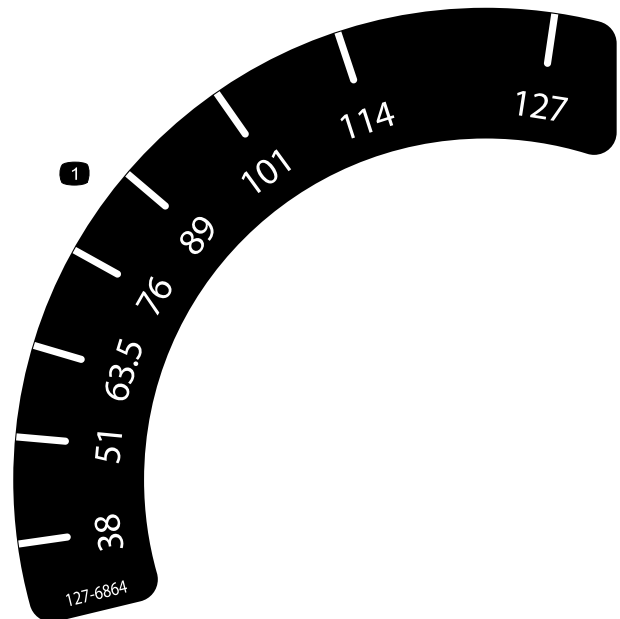

127-6864

1. Height-of-cut

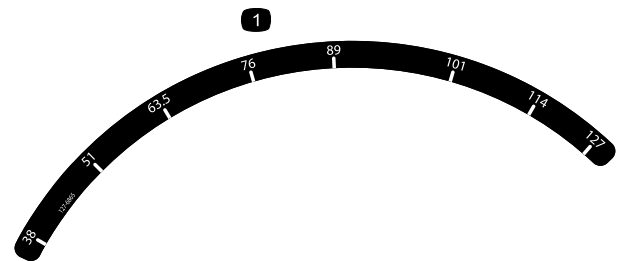

127-6865

1. Height-of-cut



120-9570

1. Warning—stay away from moving parts, keep all guards and shields in place.

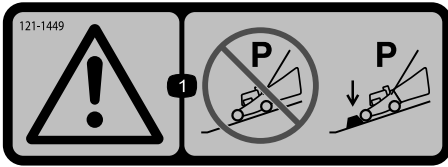

121-1449

1. Warning—do not park on slopes unless the wheels are chocked or blocked.

Setup

1

Installing the Handle

No Parts Required

Procedure

1. Remove the 2 bolts from the machine frame in the location shown in Figure 3.

Note: Save the bolts for securing the handle to the machine in step 3.

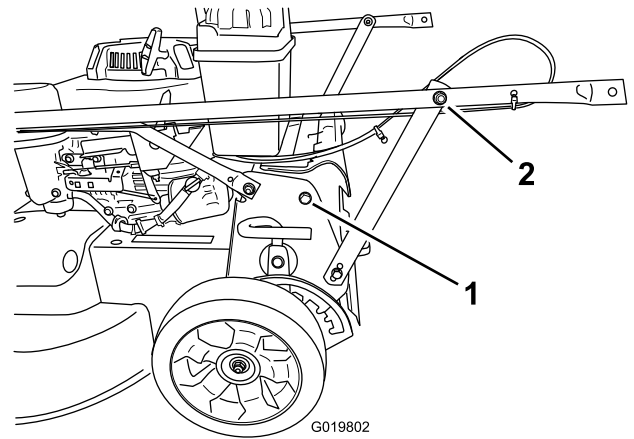

Figure 3

1. Bolt (2)
2. Nut on handle support bracket (2)

2. Rotate the handle rearward into the operating position.
3. Secure the handle to the machine with the bolts that you removed in step 1.
4. Tighten the nut on each of the handle support brackets until it is snug.

2

Filling the Crankcase with Oil

No Parts Required

Procedure

Important: This machine does not come with oil in the engine. Before starting the engine, fill the engine with oil.

1. Move the machine to a level surface.
2. Remove the dipstick by rotating the cap counterclockwise and pulling it out.
3. If the crankcase is empty, add about 3/4 of the crankcase capacity of oil into the oil-fill tube (Figure 4).

Note: Max. fill: 0.85 L (29 oz) with oil filter; 0.65 L (22 oz) without oil filter; type: SAE 30 or SAE 10W30 weight detergent oil with an API service classification of SF, SG, SH, SJ, SL, or higher.

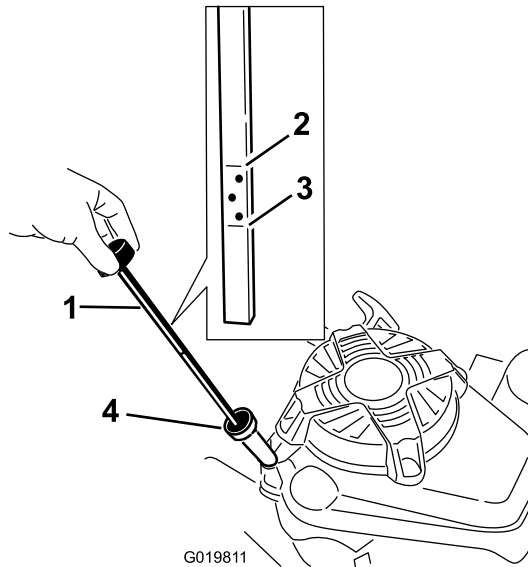

Figure 4

- | | |
|--------------|------------------|
| 1. Dipstick | 3. Add mark |
| 2. Full mark | 4. Oil-fill tube |

4. Wipe the dipstick clean with a clean cloth.
5. Insert the dipstick into the filler neck, then remove it.

Note: To ensure an accurate oil level reading, install the dipstick fully.

6. Read the oil level on the dipstick (Figure 4).
 - If the oil level is below the **Add** mark, add a small amount of oil **slowly** to the oil-fill tube, then repeat

steps 4 through 6 until the oil level is at the **Full** mark on the dipstick.

- If the oil level above the **Full** mark, drain the excess oil until the oil level is at the **Full** mark on the dipstick; refer to Changing the Engine Oil (page 17).

Important: If the oil level in the crankcase is too low or too high and you run the engine, you may damage the engine.

7. Insert the dipstick into the filler neck and rotate the cap clockwise until it is tight.

Product Overview

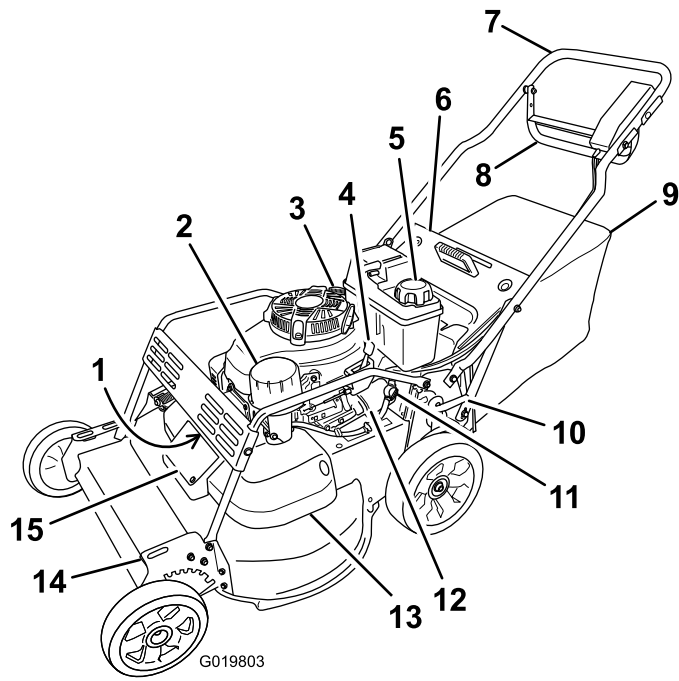

Figure 5

- | | |
|-----------------------------------|--------------------------------|
| 1. Spark plug (under brush guard) | 9. Grass bag |
| 2. Air filter | 10. Rear cutting-height lever |
| 3. Oil fill/dipstick | 11. Fuel shutoff valve |
| 4. Throttle lever | 12. Oil filter |
| 5. Fuel-tank cap | 13. Belt cover |
| 6. Rear deflector | 14. Front cutting-height lever |
| 7. Handle | 15. Belt-cover-access panel |
| 8. Control bar | |

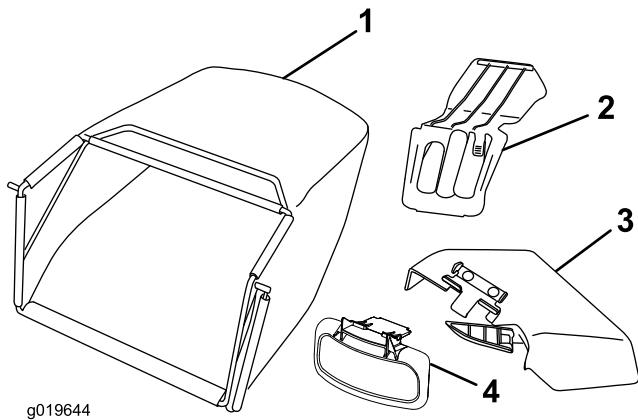

Figure 6

- | | |
|---------------|-----------------------------|
| 1. Grass bag | 3. Side-discharge chute |
| 2. Mulch plug | 4. Side-discharge deflector |

Controls

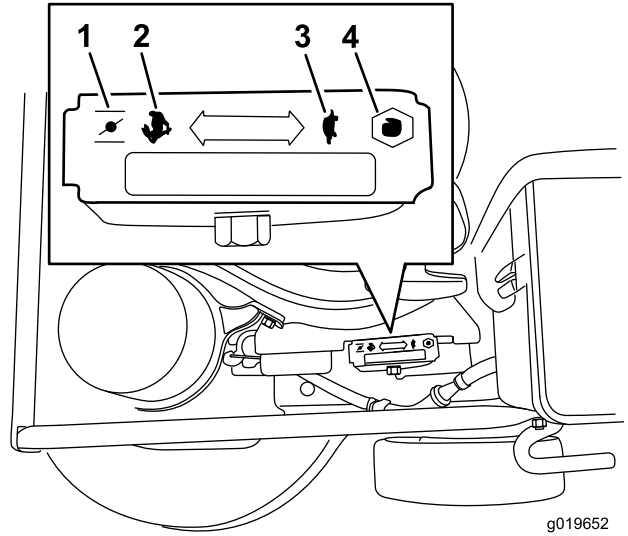

Figure 7

Throttle (throttle lever not shown for the sake of clarity)

- | | |
|----------|---------|
| 1. Choke | 3. Slow |
| 2. Fast | 4. Stop |

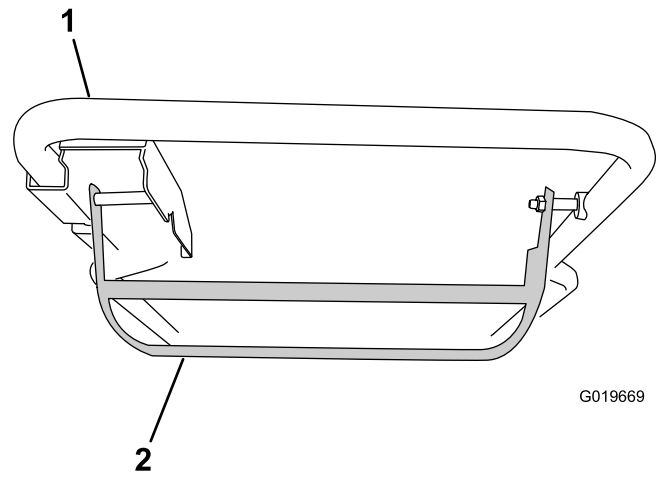

Figure 8
Control bar

- | | |
|-----------|----------------|
| 1. Handle | 2. Control bar |
|-----------|----------------|

Operation

Note: Determine the left and right sides of the machine from the normal operating position.

Each time before you mow, ensure that the self-propel drive and the control bar operate properly. When you release the control bar, the blades and the self-propel drive should stop. If they do not, contact an Authorized Service Dealer.

⚠ CAUTION

This machine produces sound levels in excess of 85dBA at the operator's ear and can cause hearing loss through extended periods of exposure.

Wear hearing protection when operating this machine.



Figure 9

1. Warning—wear hearing protection.

Checking the Engine Oil Level

Service Interval: Before each use or daily

Before each use, ensure that the oil level is between the **Add** and **Full** marks on the dipstick (Figure 10).

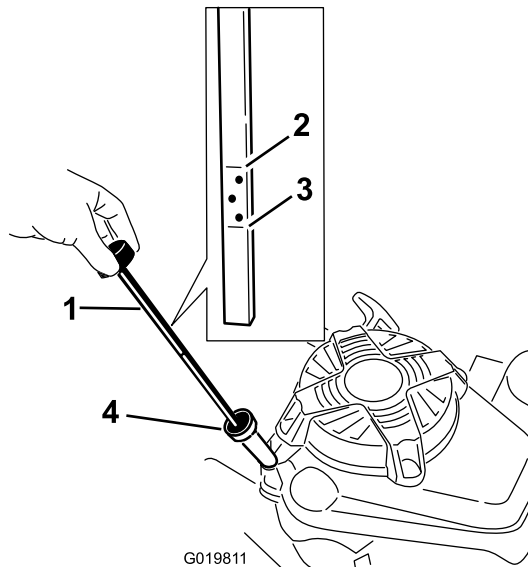

Figure 10

1. Dipstick
2. Full mark
3. Add mark
4. Oil-fill tube

1. Move the machine to a level surface.
2. Clean around the dipstick (Figure 10).

3. Remove the dipstick by rotating the cap counterclockwise and pulling it out.
4. Wipe the dipstick clean with a clean cloth.
5. Insert the dipstick into the filler neck, then remove it.

Note: To ensure an accurate oil level reading, install the dipstick fully.

6. Read the oil level on the dipstick (Figure 10).
 - If the oil level is below the **Add** mark, add a small amount of oil **slowly** to the oil-fill tube, then repeat steps 4 through 6 until the oil level is at the **Full** mark on the dipstick.
 - If the oil level above the **Full** mark, drain the excess oil until the oil level is at the **Full** mark on the dipstick; refer to Changing the Engine Oil (page 17).

Important: If the oil level in the crankcase is too low or too high and you run the engine, you may damage the engine.

7. Insert the dipstick into the filler neck and rotate the cap clockwise until it is tight.

Filling the Fuel Tank with Gasoline

⚠ DANGER

Gasoline is extremely flammable and explosive. A fire or explosion from gasoline can burn you and others.

- To prevent a static charge from igniting the gasoline, place the container and/or machine directly on the ground before filling, not in a vehicle or on an object.
- Fill the tank outdoors when the engine is cold.
- Wipe up spills.
- Do not handle gasoline when smoking or around an open flame or sparks.
- Store gasoline in an approved fuel container, out of the reach of children.
- For best results, use only clean, fresh (less than 30 days old), unleaded gasoline with an octane rating of 87 or higher ((R+M)/2 rating method).
- Oxygenated fuel with up to 10% ethanol or 15% MTBE by volume is acceptable.
- **Ethanol:** Gasoline with up to 10% ethanol (gasohol) or 15% MTBE (methyl tertiary butyl ether) by volume is acceptable. Ethanol and MTBE are not the same. Gasoline with 15% ethanol (E15) by volume is not approved for use. Never use gasoline that contains more

than 10% ethanol by volume, such as E15 (contains 15% ethanol), E20 (contains 20% ethanol), or E85 (contains up to 85% ethanol). Using unapproved gasoline may cause performance problems and/or engine damage, which may not be covered under warranty.

- **Do not** use gasoline containing methanol.
- **Do not** store fuel either in the fuel tank or in fuel containers over the winter unless fuel stabilizer has been added to the fuel.
- **Do not** add oil to gasoline.

Important: To reduce starting problems, add a fuel stabilizer to the fuel all season, mixing it with gasoline less than 30 days old.

1. Clean around the fuel-tank cap (Figure 11).

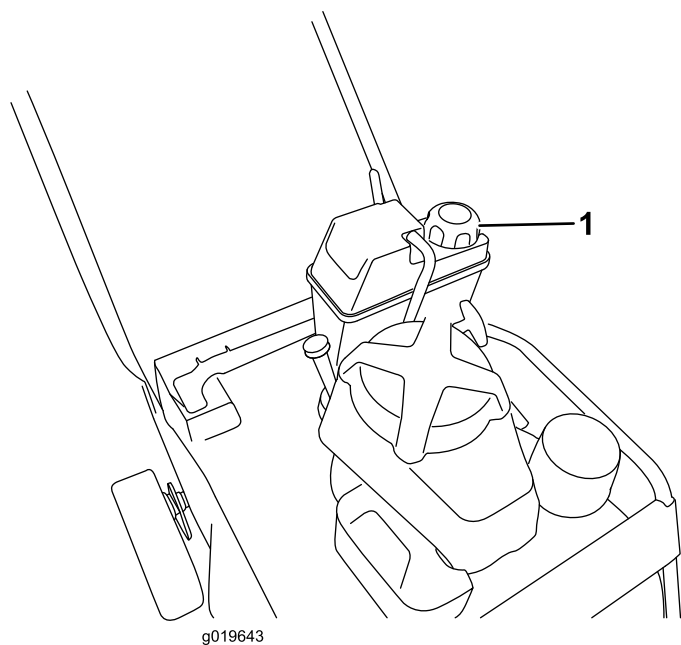

Figure 11

1. Fuel-tank cap

2. Remove the cap from the tank.
3. Fill the fuel tank with unleaded gasoline to within 6 to 13 mm (1/4 to 1/2 inch) from the top of the tank. **Do not fill into the filler neck.**

Important: Do not fill the tank more than 6 mm (1/4 inch) from the top of the tank because the gasoline must have room to expand.

4. Install the fuel tank cap and wipe up any spilled gasoline.

Adjusting the Cutting Height

▲ DANGER

Adjusting the cutting-height levers could bring your hands into contact with a moving blade and result in serious injury.

- **Stop the engine and wait for all movement to stop before adjusting the cutting height.**
- **Do not put your fingers under the housing when adjusting the cutting height.**

The cutting heights range from 38 mm (1-1/2 inches) to 127 mm (5 inches) in 13 mm (1/2-inch) increments.

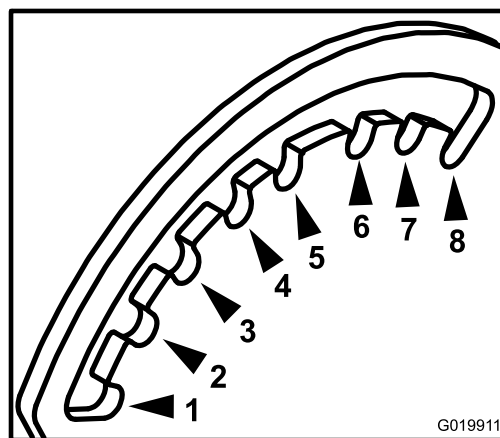
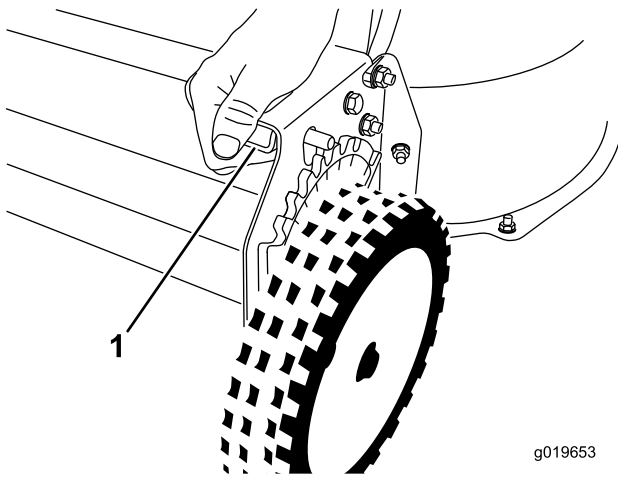

Figure 12

View from front left-hand side of the machine

- | | |
|-------------------------|--------------------------|
| 1. 38 mm (1-1/2 inches) | 5. 89 mm (3-1/2 inches) |
| 2. 51 mm (2 inches) | 6. 102 mm (4 inches) |
| 3. 64 mm (2-1/2 inches) | 7. 114 mm (4-1/2 inches) |
| 4. 76 mm (3 inches) | 8. 127 mm (5 inches) |

The cutting height is controlled with a front lever and a rear lever, both on the left side of the machine (Figure 13 and Figure 14). To raise or lower the machine, engage the lever, raise or lower the machine, and then disengage the lever.



g019653

Figure 13
Front cutting-height lever

1. Squeeze the lever to disengage it.

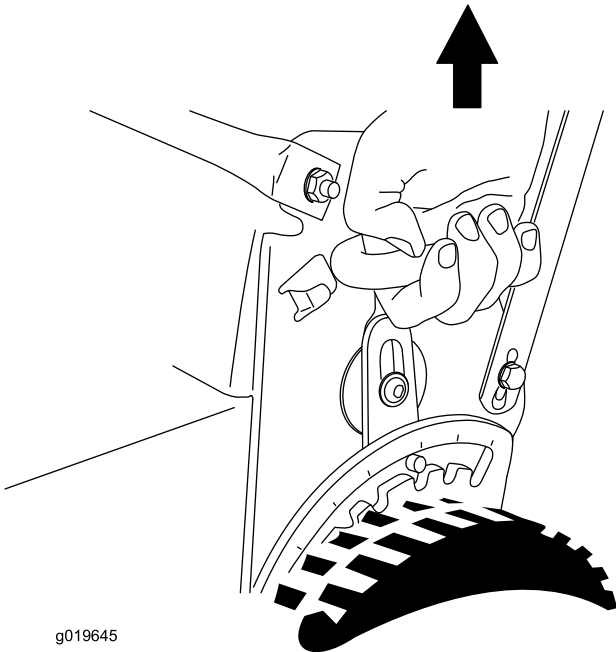

g019645

Figure 14
Rear cutting-height lever

Starting the Engine

1. Connect the wire to the spark plug (Figure 5).
2. Open the fuel shutoff valve (Figure 15).

Note: When the fuel shutoff valve is open, the lever is parallel with the fuel line.

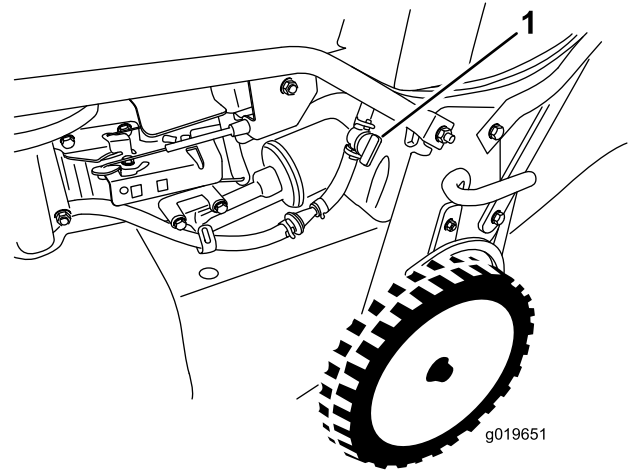

g019651

Figure 15

1. Fuel shutoff valve

3. Move the throttle control to the **Choke** position (Figure 7).
4. Pull the starter handle lightly until you feel resistance, then pull it sharply.
5. Move the throttle control lever to the **Fast** position when the engine starts (Figure 6).

Note: If the engine fails to start after 3 pulls, repeat steps 3 through 5.

Stopping the Engine

1. Move the throttle control to the **Off** position and wait for all moving parts to stop.
2. Close the fuel shutoff valve and disconnect the wire from the spark plug if you do not use the machine or leave it unattended.

Operating the Self-propel Drive and Engaging the Cutting Blades

- To operate the self-propel drive without engaging the blades, raise the control bar to the handle (Figure 16).

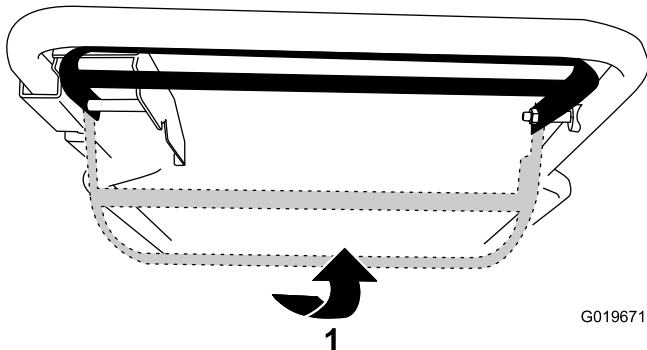

Figure 16

1. Raise the control bar to the handle.

- To operate the self-propel drive and engage the blades, slide the control bar all the way to the right and raise it to the handle (Figure 16).

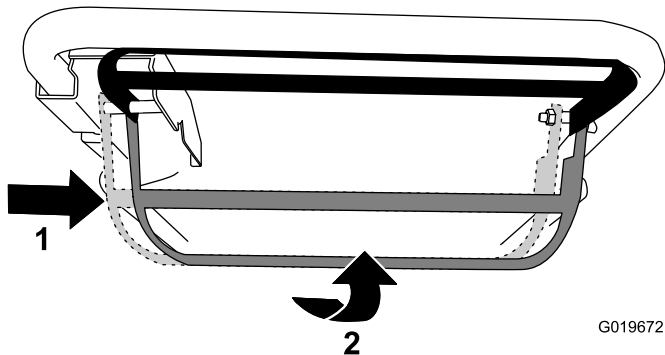

Figure 17

1. Slide the control bar to the right.
2. Raise the control bar to the handle.

- To disengage the self-propel drive and the blades, release the control bar.

Note: You can vary the ground speed by increasing or decreasing the distance between the control bar and the handle. Lower the control bar to reduce the speed when you make a turn or if the machine is moving too fast. If you lower the control bar too far, the machine stops self-propelling. Squeeze the control bar closer to the handle to increase the ground speed. When you hold the control bar tight against the handle, the machine self-propels at the maximum ground speed.

Checking the Blade-stop System Operation

Before each use, check that the blades stop within 3 seconds of releasing the control bar.

Using the Grass Bag

Service Interval: Before each use or daily—Check the blade-stop system operation. The blades should stop within 3 seconds of releasing the control bar; if they do not, contact an Authorized Service Dealer.

You can use the grass bag to check the blade-stop system.

1. Remove the rear-discharge plug.
2. Install the empty grass bag on the machine.
3. Start the engine.
4. Engage the blades.

Note: The bag should begin to inflate, indicating that the blades are rotating.

5. While watching the bag, release the control bar.

Note: If the bag does not deflate within 3 seconds of releasing the control bar, the blade-stop system may be deteriorating and, if ignored, could result in an unsafe operating condition. Have the machine inspected and serviced by an Authorized Service Dealer.

6. Stop the engine and wait for all moving parts to stop.

Not Using the Grass Bag

1. Move the machine onto a paved surface in a non-windy area.
2. Set all 4 wheels to the 89 mm (3-1/2 inch) cutting height setting.
3. Take a half sheet of newspaper and crumple it into a ball small enough to go under the machine (about 75 mm or 3 inches in diameter).
4. Place the newspaper ball about 13 cm (5 inches) in front of the machine.
5. Start the engine.
6. Engage the blades.
7. Release the control bar and begin counting out 3 seconds.
8. On the count of 3, push the machine quickly forward over the newspaper.
9. Stop the engine and wait for all moving parts to stop.
10. Go to the front of the machine and check the newspaper ball.

Note: If the newspaper ball did not go under the machine, repeat steps 4 through 10.

Important: If the newspaper is unravelled or shredded, the blades did not stop properly, which could result in an unsafe operating condition. Contact an Authorized Service Dealer.

Recycling the Clippings

This machine comes from the factory ready to recycle grass and leaf clippings back into the lawn. To prepare the machine to recycle:

- If the side-discharge chute is on the machine, remove it and install the side-discharge deflector; refer to Removing the Side-discharge Chute (page 14).
- If the grass bag is on the machine, remove it; refer to Removing the Grass Bag (page 14).
- If the rear-discharge plug is not installed, grip it by the handle, raise the rear deflector, and insert it into the rear-discharge chute until the latch locks into place; refer to Figure 18.

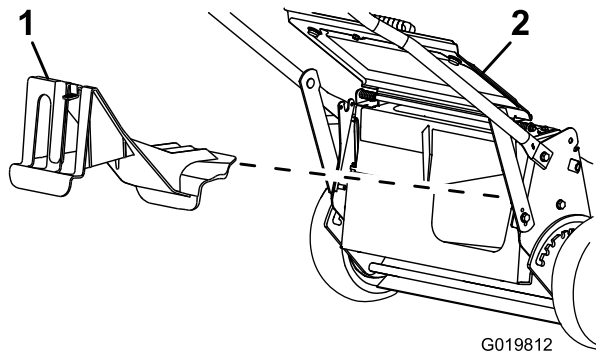

Figure 18

1. Rear-discharge plug
2. Rear deflector

⚠ WARNING

Ensure that the rear-discharge plug is in place before you recycle the clippings. Never engage the blades without either the rear-discharge plug or the grass bag installed.

Bagging the Clippings

Use the grass bag when you want to collect grass and leaf clippings from the lawn.

⚠ WARNING

A worn grass bag could allow small stones and other similar debris to be thrown toward the operator or bystanders and result in serious personal injury or death.

Check the grass bag frequently. If it is damaged, install a new Toro replacement bag.

If the side-discharge chute is on the machine, remove it and install the side-discharge deflector before bagging the clippings; refer to Removing the Side-discharge Chute (page 14).

⚠ WARNING

The blades are sharp; contacting the blades can result in serious personal injury.

Stop the engine and wait for all moving parts to stop before leaving the operating position.

Installing the Grass Bag

1. Raise and hold the rear deflector (Figure 19).

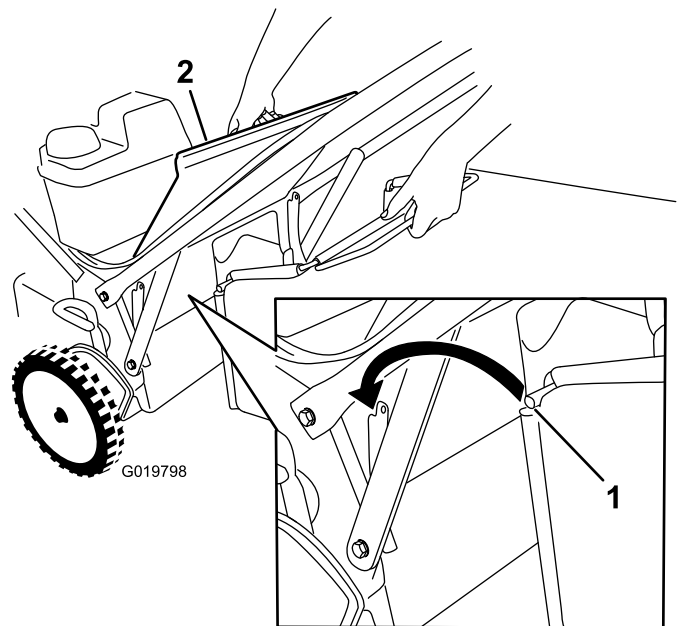

Figure 19

1. Bag rod
2. Rear deflector

2. Remove the rear-discharge plug by pulling down on the latch with your thumb and pulling the plug out from the machine (Figure 18).
3. Install the bag rod into the notches at the base of the handle, and rock the bag back and forth to ensure that the rod is seated at the bottom of both notches; refer to Figure 19.
4. Lower the rear deflector until it rests on the grass bag.

Mowing with the Grass Bag

⚠ WARNING

A worn grass bag could allow small stones and other similar debris to be thrown in the operator's or bystander's direction and result in serious personal injury or death to the operator or bystanders.

Check the grass bag frequently. If it is damaged, install a new Toro replacement bag.

Removing the Grass Bag

To remove the bag, reverse the steps in Installing the Grass Bag above.

⚠ DANGER

The machine can throw grass clippings and other objects through an open discharge tunnel. Objects thrown with enough force could cause serious personal injury or death to the operator or bystander.

Never open the door on the discharge tunnel when the engine is running.

Side-discharging the Clippings

Use the side discharge for cutting very tall grass.

⚠ WARNING

The blades are sharp; contacting the blades can result in serious personal injury.

Stop the engine and wait for all moving parts to stop before leaving the operating position.

⚠ DANGER

An uncovered discharge opening will allow objects to be thrown in the direction of the operator or bystanders. Also, contact with the blades could occur. Thrown objects or blade contact can cause serious injury or death.

Never operate the machine without the side-discharge deflector or side-discharge chute in place and working properly.

Installing the Side-discharge Chute

Important: Ensure that the rear-discharge plug is in place before you recycle the clippings.

1. Stop the engine and wait for all moving parts to stop.

2. Remove the grass bag if it is installed on the machine; refer to Removing the Grass Bag (page 14).
3. Insert the rear-discharge plug; refer to Recycling the Clippings (page 13).
4. Remove the side-discharge deflector by pulling up on the spring that holds the deflector in place and removing the deflector (Figure 20).

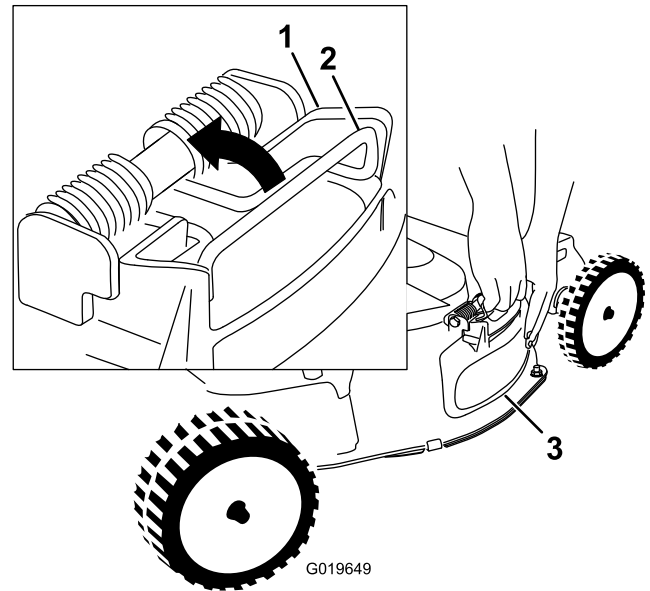

Figure 20

1. Top of the side-discharge deflector
2. Spring
3. Side-discharge deflector

5. Install the side-discharge chute (Figure 21) by pulling up on the spring, placing the chute over the opening, and lowering the spring over the tabs on top of the discharge chute.

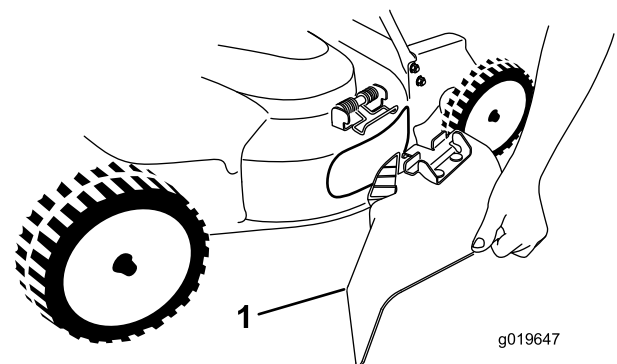

Figure 21

1. Side-discharge chute

Removing the Side-discharge Chute

To remove the side-discharge chute, reverse the steps in Installing the Side-discharge Chute.

Operating Tips

General Tips

- Review the safety instructions and read this manual carefully before operating the machine.
- Clear the area of sticks, stones, wire, branches, and other debris that the blades could hit and throw.
- Keep everyone, especially children and pets, away from the area of operation.
- Avoid striking trees, walls, curbs, or other solid objects. Never deliberately mow over any object.
- If the machine strikes an object or starts to vibrate, immediately stop the engine, disconnect the wire from the spark plug, and examine the machine for damage.
- Maintain sharp blades throughout the cutting season. Periodically file down nicks on the blades.
- Replace the blades when necessary with original Toro replacement blades.
- Mow only dry grass or leaves. Wet grass and leaves tend to clump on the yard and can cause the machine to plug or the engine to stall.

⚠ WARNING

Wet grass or leaves can cause serious injury if you slip and contact the blades.

Mow only in dry conditions.

- Clean the underside of the machine deck after each mowing. Refer to Cleaning under the Machine Housing (page 24).
- Keep the engine in good running condition.
- Set the engine speed to the fastest position for the best cutting results.

⚠ WARNING

Operating a machine with its engine running at a speed greater than the factory setting can cause the machine to throw a part of a blade or engine into the operator's or bystander's area and result in serious personal injury or death.

- **Do not change the engine speed setting.**
- **If you suspect the engine speed is faster than normal, contact an Authorized Service Dealer.**

- Clean the air filter frequently. Mulching stirs up more clippings and dust which clogs the air filter and reduces engine performance.

Cutting Grass

- Grass grows at different rates at different times of the year. In the summer heat, it is best to cut grass at the

51 mm (2-inch), 64 mm (2-1/2-inch), or 83 mm (3-inch) cutting height settings. Cut only about a third of the grass blade at a time. Do not cut below the 2-inch (51 mm) setting unless the grass is sparse or it is late fall when grass growth begins to slow down.

- When cutting grass over 15 cm (6 inches) tall, first mow at the highest cutting height setting and walk slower; then mow again at a lower setting for the best lawn appearance. If the grass is too long and the leaves clump on top of the lawn, the machine may plug and cause the engine to stall.
- Alternate the mowing direction. This helps disperse the clippings over the lawn for even fertilization.

If the finished lawn appearance is unsatisfactory, try one or more of the following:

- Sharpen the blades.
- Walk at a slower pace while mowing.
- Raise the cutting height on your machine.
- Cut the grass more frequently.
- Overlap cutting swaths instead of cutting a full swath with each pass.
- Set the cutting height on the front wheels a notch lower than the rear wheels. For example, set the front wheels at 51 mm (2 inches) and the rear wheels at 64 mm (2-1/2 inches).

Cutting Leaves

- After cutting the lawn, ensure that half of the lawn shows through the cut leaf cover. You may need to make more than one pass over the leaves.
- For light leaf coverage, set all the wheels at the same cutting height setting.
- If there are more than 12.7 cm (5 inches) of leaves on the lawn, set the front cutting height 1 or 2 notches higher than the rear cutting height. This makes it easier to feed the leaves under the machine deck.
- Slow down your mowing speed if the machine does not cut the leaves finely enough.

Maintenance

Recommended Maintenance Schedule(s)

Maintenance Service Interval	Maintenance Procedure
After the first 5 hours	<ul style="list-style-type: none">• Change the engine oil without the oil filter.• Service the blade-drive system.
Before each use or daily	<ul style="list-style-type: none">• Check the engine oil level.• Check the blade-stop system operation. The blades should stop within 3 seconds of releasing the control bar; if they do not, contact an Authorized Service Dealer.• Inspect the air filter.• Check the cutting blades and service them, if necessary.• Inspect the blades.• Clean under the machine housing.
Every 25 hours	<ul style="list-style-type: none">• Clean the foam pre-cleaner (more frequently in dusty conditions).
Every 50 hours	<ul style="list-style-type: none">• Change the engine oil (more often in dusty conditions).• Check the condition of the belts.• Check the fuel hose and replace it if necessary.• Remove debris from under the belt cover.• Service the blade-drive system.
Every 100 hours	<ul style="list-style-type: none">• Change the oil filter.• Check the spark plug.• Clean the fuel tank filter.• Change the fuel filter.
Every 250 hours	<ul style="list-style-type: none">• Change the blade-brake-clutch belt.
Every 300 hours	<ul style="list-style-type: none">• Replace the paper air filter (more frequently in dusty conditions).
Yearly or before storage	<ul style="list-style-type: none">• Empty the fuel tank before repairs as director or before storage.

Important: Refer to your Engine Operator's Manual for additional maintenance procedures.

⚠ CAUTION

If you leave the wire on the spark plug, someone could accidentally start the engine and seriously injure you or other bystanders.

Disconnect the wire from the spark plug before you do any maintenance. Set the wire aside so that it does not accidentally contact the spark plug.

Servicing the Air Filter

Service Interval: Before each use or daily

Every 25 hours—Clean the foam pre-cleaner (more frequently in dusty conditions).

Every 300 hours—Replace the paper air filter (more frequently in dusty conditions).

Important: Do not operate the engine without the air filter assembly; extreme engine damage will occur.

1. Stop the engine and wait for all moving parts to stop.
2. Disconnect the wire from the spark plug.
3. Remove the cover and clean it thoroughly (Figure 22).

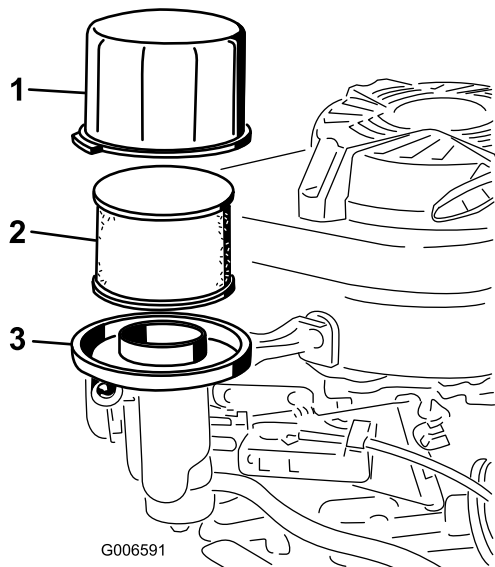

Figure 22

1. Cover
2. Foam pre-filter and paper filter
3. Air-filter base

4. Remove the foam pre-filter and paper filter (Figure 22).
5. Remove the foam pre-filter from the paper filter (Figure 22), and replace the paper filter if it is excessively dirty.

Important: Do not try to clean a paper filter.

6. Wash the foam pre-cleaner with a mild detergent and water, then blot it dry.

Note: Do not add oil to the foam pre-cleaner.

7. Install the foam pre-cleaner onto the paper filter.
8. Install the air-filter assembly.
9. Install the cover.

Changing the Engine Oil

Service Interval: After the first 5 hours—Change the engine oil without the oil filter.

Every 50 hours—Change the engine oil (more often in dusty conditions).

1. Run the engine to warm the engine oil.

Note: Warm oil flows better and carries more contaminants.

⚠ WARNING

Oil may be hot after engine has been run, and contact with hot oil can cause severe personal injury.

Avoid contacting the hot engine oil when you drain it.

2. Stop the engine and wait for all moving parts to stop.
3. Disconnect the wire from the spark plug.
4. Place a suitable drain pan under the right side of the machine.
5. Remove the dipstick by rotating the cap counterclockwise and pulling it out.
6. Tip the machine, with the air filter up, to drain the oil into the drain pan (Figure 23).

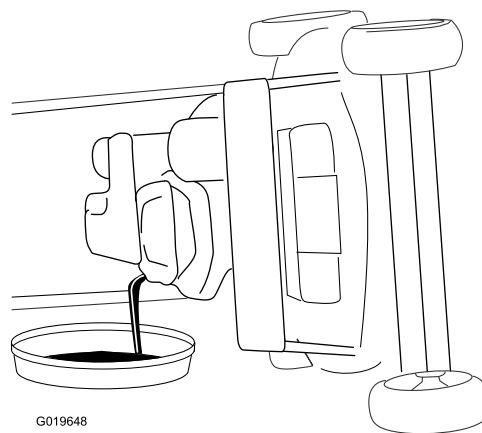

Figure 23

Note: You can also remove the oil from the crankcase using an oil extractor.

7. Return the machine to the operating position.
8. Insert the dipstick into the filler neck and rotate the cap clockwise until it is tight.
9. Recycle the used oil according to local codes.
10. Fill the crankcase to the Full line on the dipstick with fresh oil. Refer to 2 Filling the Crankcase with Oil (page 6).
11. Wipe up any spilled oil.

Changing the Oil Filter

Service Interval: Every 100 hours

1. Run the engine to warm the oil.

⚠ WARNING

Oil may be hot after the engine has been run, and contact with hot oil can cause severe personal injury.

Avoid contacting the hot engine oil when you drain it.

2. Stop the engine and wait for all moving parts to stop.
3. Disconnect the wire from the spark plug.
4. Drain the engine oil; refer to Changing the Engine Oil (page 17).
5. Place a rag under the oil filter to catch any oil that may leak out as you remove the filter.
6. Remove the oil filter (Figure 24).

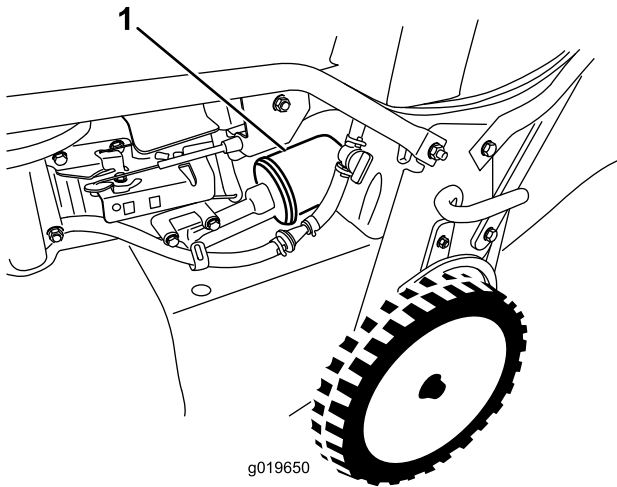

Figure 24

1. Oil filter

7. Use your finger to coat the gasket on the new filter with oil (Figure 25).

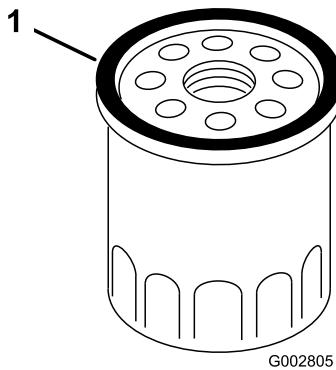

Figure 25

1. Gasket

8. Install the new filter until the gasket contacts the filter base, then hand tighten the filter an additional 2/3 turn.
9. Fill the crankcase to the Full line on the dipstick with fresh oil; refer to 2 Filling the Crankcase with Oil (page 6).
10. Connect the wire to the spark plug.
11. Run the engine for about 3 minutes.
12. Stop the engine, wait for all moving parts to stop, and check for oil leakage around the filter.
13. Add oil to compensate for the oil in the oil filter; refer to Checking the Engine Oil Level (page 9)
14. Recycle the used oil filter according to local codes.

Servicing the Spark Plug

Service Interval: Every 100 hours

Use an **NGK BPR5ES** spark plug or equivalent.

1. Stop the engine and wait for all moving parts to stop.
2. Disconnect the wire from the spark plug.
3. Clean around the spark plug.
4. Remove the spark plug from the cylinder head.

Important: Replace a cracked, fouled, or dirty spark plug. Do not clean the electrodes because grit entering the cylinder can damage the engine.

5. Set the gap on the plug to 0.76 mm (0.030 inch); refer to Figure 26.

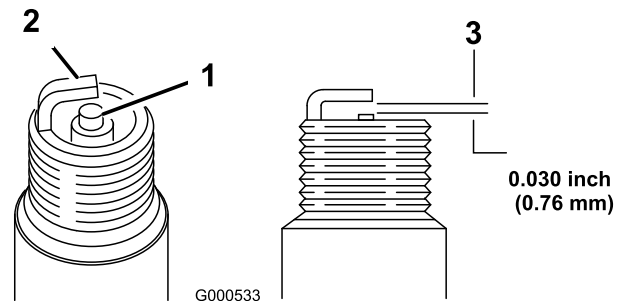

Figure 26

1. Center-electrode insulator
2. Side electrode
3. Air gap (not to scale)

6. Install the spark plug and the gasket seal.
7. Torque the plug to 23 N-m (17 ft-lb).
8. Connect the wire to the spark plug.

Checking the Condition of the Belts

Service Interval: Every 50 hours

1. Stop the engine and wait for all moving parts to stop.
2. Remove the belt cover (Figure 5) by removing the 4 bolts that hold it to the machine housing.
3. Check the belts for any cracks, frayed edges, burn marks, or any other damage.
4. Replace all damaged belts.
5. If you replace the blade-drive belt, you must adjust it. Refer to Changing the Blade-drive Belt (page 24).
6. Install the belt cover with the 4 bolts that you removed in step 2.

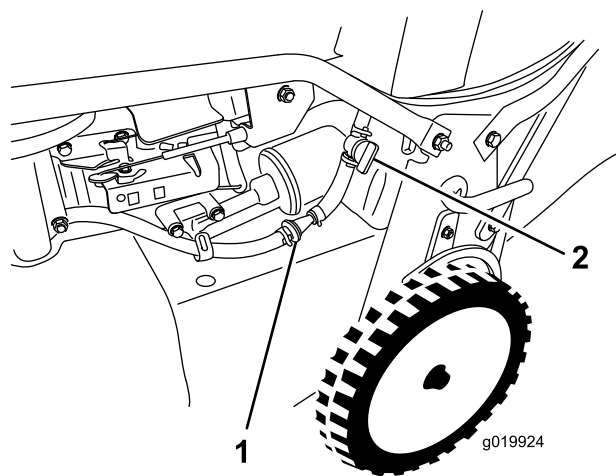

Figure 27

1. Fuel filter
2. Fuel shutoff valve

Emptying the Fuel Tank and Cleaning the Filter

Service Interval: Every 50 hours—Check the fuel hose and replace it if necessary.

Every 100 hours—Clean the fuel tank filter.

Yearly or before storage—Empty the fuel tank before repairs as director or before storage.

Note: The fuel tank filter (screen) element is located inside the fuel tank at the outlet. This filter is a part of the fuel tank and cannot be removed.

1. Stop the engine and wait for it to cool down.
Important: Drain gasoline from a cold engine only.
2. Disconnect the wire from the spark plug.
3. Close the fuel shutoff valve.
4. Disconnect the fuel line by loosening the tube clamp at the carburetor.
5. Open the fuel shutoff valve and drain the gasoline completely from the tank and fuel line into an approved fuel container.
6. Remove the fuel tank from the machine.
7. Pour a small amount of fuel in the fuel tank, move the fuel around in the tank, and pour it out into an approved fuel container.
8. Install the fuel tank and the fuel line.

4. Remove the fuel filter (Figure 27) from the fuel line by loosening the tube clamps surrounding the fuel filter.
5. Install a new fuel filter in the fuel line using the tube clamps that you removed in step 4.

Servicing the Blade-drive System

Service Interval: After the first 5 hours

Every 50 hours—Remove debris from under the belt cover.

Every 50 hours—Service the blade-drive system.

1. Loosen the 2 screws on the belt-cover-access panel and remove the panel (Figure 28).

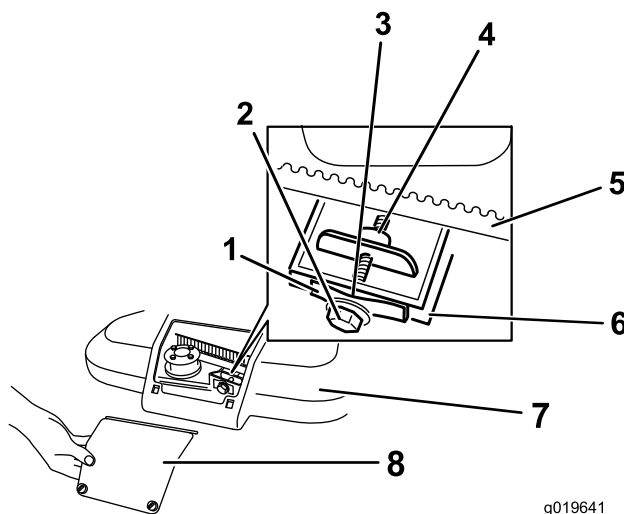

Figure 28

1. Belt-tension spring
2. Adjusting bolt
3. Gap
4. Adjusting nut
5. Blade-drive belt
6. Wall
7. Belt cover
8. Belt-cover-access panel

Changing the Fuel Filter

Service Interval: Every 100 hours

1. Stop the engine and wait for all moving parts to stop.
2. Disconnect the wire from the spark plug.
3. Close the fuel shutoff valve (Figure 27).

- Brush or blow out debris from the inside of the belt cover and around all the parts.
- Hold a feeler gauge set between 0.13 and 0.76 mm (0.005 and 0.03 inches) against the wall and slide it down behind the belt tension spring; refer to Figure 29.

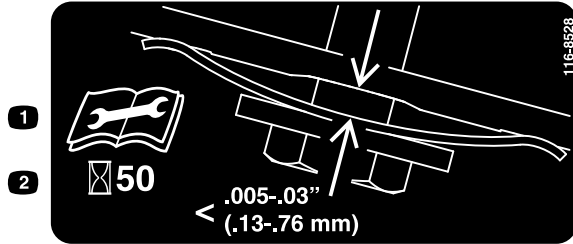

Figure 29

Note: If there is a visible gap between the gauge and the spring, tighten the adjusting bolt and the nut until the feeler gauge barely slides freely in and out of the gap (Figure 28).

Important: Do not overtighten the adjusting bolt. This could damage the blade-drive belt.

- Install the belt-cover-access panel.

Servicing the Cutting Blades

Service Interval: Before each use or daily

Important: You will need a torque wrench to install the blades properly. If you do not have a torque wrench or are uncomfortable performing this procedure, contact an Authorized Service Dealer.

Examine the blades for sharpness and any wear or damage whenever you run out of gasoline; refer to Inspecting the Blades (page 20). If the blade edge is dull or nicked, have it sharpened or replace it. If the blades are worn, bent, damaged or cracked, replace them immediately with a genuine Toro replacement blades.

⚠ DANGER

A worn or damaged blade can break, and a piece of the blade could be thrown toward the operator or a bystander, resulting in serious personal injury or death.

- Inspect the blades before each use for wear or damage.
- Replace worn or damaged blades.

Note: Maintain sharp blades throughout the cutting season, because sharp blades cut cleanly without tearing or shredding the grass blades. Tearing and shredding turns grass brown at the edges, which slows growth and increases the chance of disease.

Preparing to Service the Cutting Blades

Tip the machine onto its side, with the air filter up in the air, until the upper handle rests on the ground.

⚠ WARNING

The blades are sharp; contacting a blade could result in serious personal injury.

- Disconnect the wire from the spark plug.
- Wear gloves when servicing the blades.

Inspecting the Blades

Service Interval: Before each use or daily

- Inspect the cutting edges (Figure 30). If the edges are not sharp or have nicks, remove the blades and have them sharpened or replace them.

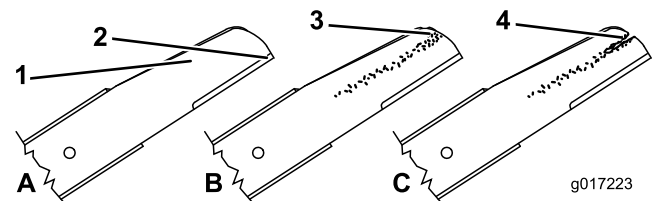

Figure 30

- | | |
|-----------------|----------------------|
| 1. Curved area | 3. Wear/slot forming |
| 2. Cutting edge | 4. Crack |

- Inspect the blades themselves, especially the curved area (Figure 42). If you notice any damage, wear, or a slot forming in this area (Figure 30), immediately replace them with new blades.

⚠ DANGER

If you allow a blade to wear, a slot will form between the sail and flat part of the blade. Eventually a piece of the blade may break off and be thrown from under the housing, possibly resulting in serious injury to you or bystanders.

- Inspect the blades before each use for wear or damage.
- Never try to straighten a blade that is bent or weld a broken or cracked blade.
- Check for bent blades; refer to Checking for Bent Blades (page 20).

Checking for Bent Blades

- Rotate the blades until they are positioned as shown in Figure 31.

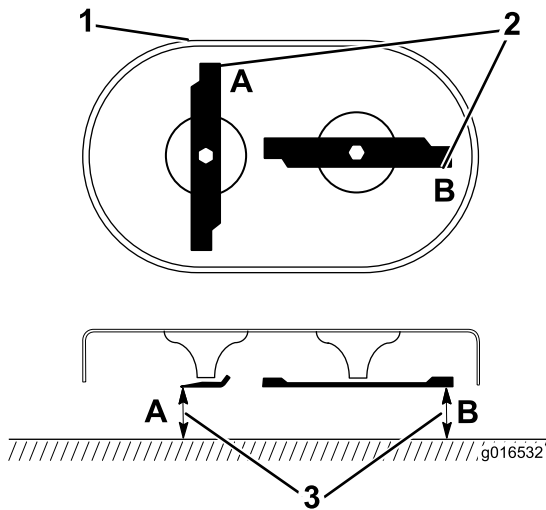

Figure 31

1. Front of cutting deck
2. Measure at locations **A** and **B**
3. Measure from the cutting edge to a smooth, level surface

2. Measure from a level surface to the cutting edges at locations **A** and **B**, (Figure 31), and record both dimensions.
3. Rotate the blades so that their opposite ends are at locations **A** and **B**.
4. Repeat the measurements in step 2 and record them.

Note: If the difference between the dimensions **A** and **B** obtained in steps 2 and 4 exceeds 3 mm (1/8 inch), replace the blades; refer to Removing the Blades (page 21) and Installing the Blades (page 21).

Removing the Blades

Replace the blades when they strike a solid object, are out of balance, bent, or worn. Use only genuine Toro replacement blades.

1. Use a block of wood to hold each blade steady and turn the blade bolt counterclockwise as shown in Figure 32.

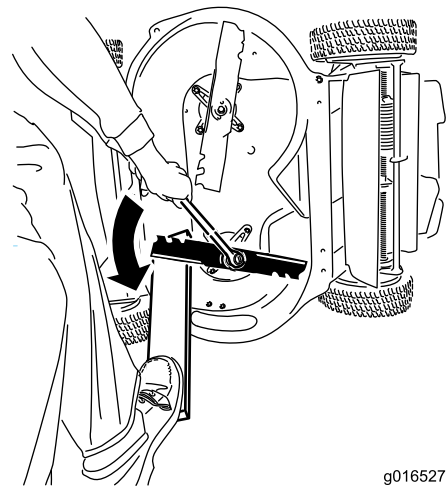

Figure 32

2. Remove each blade as shown in Figure 33.

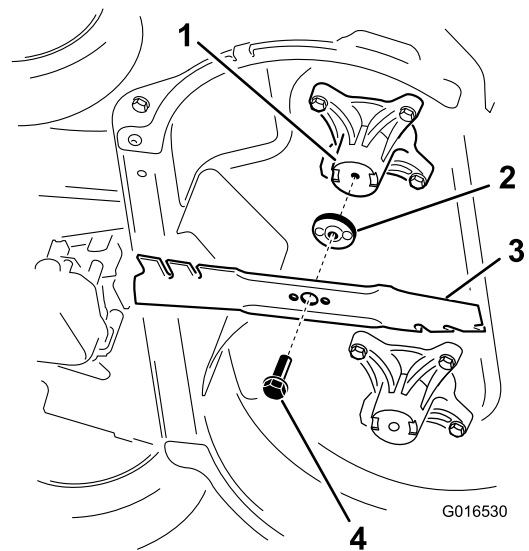

Figure 33

1. Spindle (2)
2. Blade driver (2)
3. Blade (2)
4. Blade bolt (2)

3. Inspect the pins on the blade drivers for wear and damage.

Installing the Blades

1. Install the first blade so that it is horizontal, along with all mounting hardware as shown in Figure 33.

Note: Tighten the bolt with your fingers.

Important: Position the curved ends of the blades to point toward the machine housing. Be sure to nest the raised areas on each blade driver with the recesses in the head of its corresponding spindle, and the pins on the other side of each blade driver with the holes in its corresponding blade.

- Steady each blade with a board and turn the blade bolt clockwise with a torque wrench as shown in Figure 34; torque each blade bolt to 82 N-m (60 ft-lb).

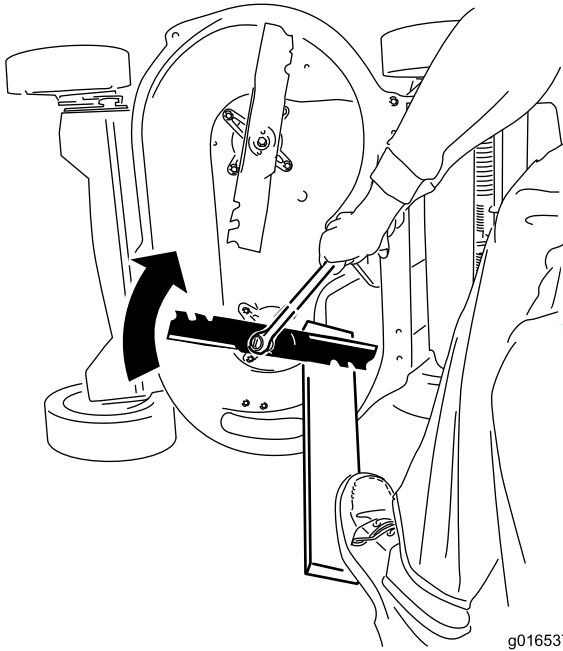

Figure 34

g016537

Important: A bolt torqued to 82 N-m (60 ft-lb) is very tight. Put your weight behind the wrench and tighten the bolt securely. This bolt is very difficult to overtighten.

- Rotate the installed blade 1/4 turn until it is vertical, and install the other blade in the same manner as the first (refer to step 1).

Note: The blades should be perpendicular, forming an inverted “T” as shown in Figure 35.

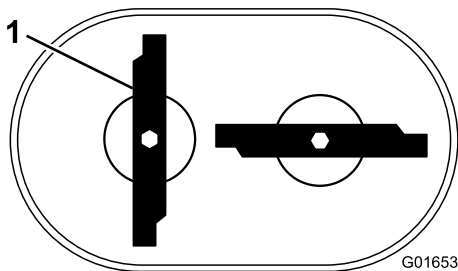

Figure 35

G016536

- Blade (2)

- Tighten the second blade; refer to step 2.
- Rotate the blades by hand a full 360° turn to ensure that they do not touch.

Note: If the blades touch each other, they are not mounted correctly. Repeat steps 1 through 3 until the blades no longer touch each other.

⚠ WARNING

Incorrectly installing the blades could damage the machine or cause an injury to the operator or to bystanders.

Changing the Blade-Brake-Clutch (BBC) Belt

Service Interval: Every 250 hours

- Stop the engine and wait for all moving parts to stop.
- Disconnect the wire from the spark plug.
- Remove the 4 bolts that hold the belt cover to the machine housing.

Note: Save the bolts for installing the belt cover to the machine housing.

- Remove the belt cover.
- Remove any debris from under the belt cover.
- Remove the BBC belt guard (Figure 36).

Note: Save the mounting hardware for installing the BBC belt guard later.

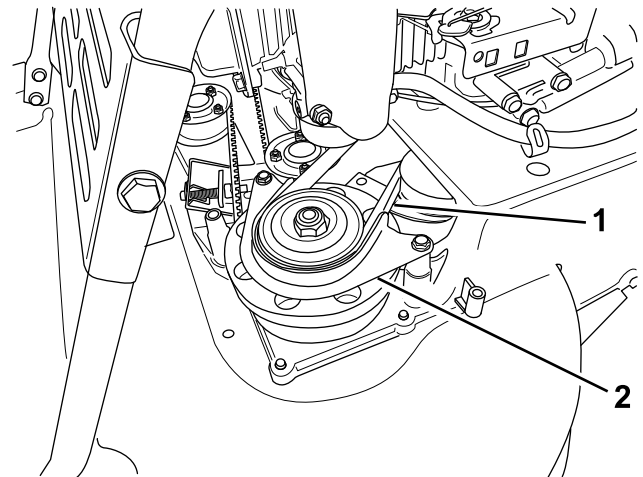

Figure 36

G019899

- BBC belt
- BBC belt guard

- Remove the BBC belt from the brake-drum pulley.
- Move the tab forward (Figure 37).

Note: The tab prevents the transmission from tipping to the point where the transmission belt comes off.

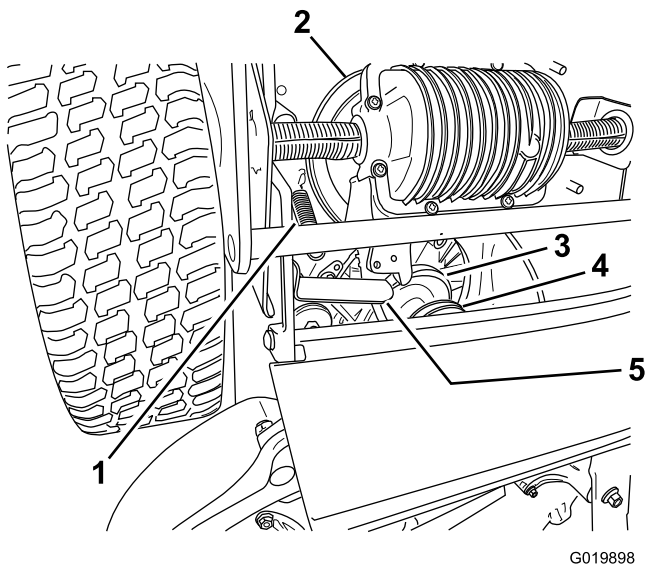

Figure 37

- | | |
|--------------------------------|----------------------|
| 1. Transmission tension spring | 4. Transmission belt |
| 2. Transmission | 5. Tab |
| 3. BBC belt | |

9. Remove the transmission tension spring.
 10. Remove the transmission belt from the transmission pulley.
 11. Remove the BBC belt.
- Note:** Hold one of the blades using a glove or a rag and turn the blade spindle to help remove the BBC belt.
12. To install a new BBC belt, reverse the steps above.
 13. Adjust the BBC cable; refer to Adjusting the BBC cable in Adjusting the Blade-brake Cable (page 23).

Adjusting the Self-propel Cable

If the machine does not self-propel or tends to creep forward when you release the control bar, adjust the drive cable.

1. Stop and wait for all moving parts to stop.
2. Loosen the cable-support nut (Figure 38).

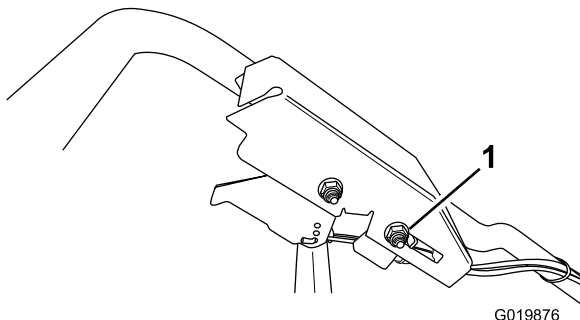

Figure 38

1. Cable-support nut

3. Slide the cable-support nut **toward** the machine to **increase** the self-propel action; slide the cable-support nut **away** from the machine to **decrease** the self-propel action.
4. Tighten the cable-support nut.
5. Check the operation for the desired drive control, and repeat the steps above, if necessary.

Note: If the machine creeps forward without the control bar engaged or if the wheels spin when you lift the rear wheels off the ground, the cable is too tight; loosen the cable-support nut, pull the cable jacket upward (away from the machine) slightly, and tighten the cable-support nut.

Note: You may also adjust the maximum ground speed (when the control bar is fully engaged) as desired.

Adjusting the Blade-brake Cable

Adjust the blade-brake cable whenever you install a new cable or replace the BBC belt.

1. Stop the engine and wait for all moving parts to stop.
2. Disconnect the wire from the spark plug.
3. Remove the belt cover (Figure 5) by removing the 4 bolts that hold it to the machine housing.

Note: Save the bolts for installing the belt cover to the machine housing.

4. Remove any debris from under the belt cover.
5. Loosen the cable-clamp screw (Figure 39).

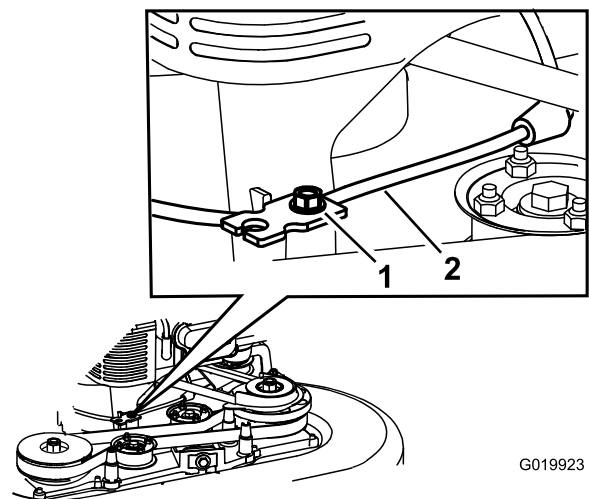

Figure 39

- | | |
|----------------------|----------------------|
| 1. Cable-clamp screw | 2. Blade-brake cable |
|----------------------|----------------------|

6. Pull the cable jacket until there is approximately 3 mm (1/8 inch) of slack.

Note: Do not put tension on the spring.

7. Tighten the cable-clamp screw to lock the adjustment in place.
8. Install the belt cover with the 4 bolts that you removed in step 3.
9. Connect the wire to the spark plug.
10. Check the operation of the blade-brake clutch; refer to Checking the Blade-stop System Operation (page 12).

Changing the Blade-drive Belt

Change the blade-drive belt as needed.

1. Stop the engine and wait for all moving parts to stop.
 2. Disconnect the wire from the spark plug.
 3. Remove the belt cover (Figure 5) by removing the 4 bolts that hold it to the machine housing.
- Note:** Save the bolts for installing the belt cover to the machine housing.
4. Remove any debris from under the belt cover.
 5. Remove the BBC belt guard and the mounting hardware.

Note: Save the BBC belt guard and hardware for installation later.

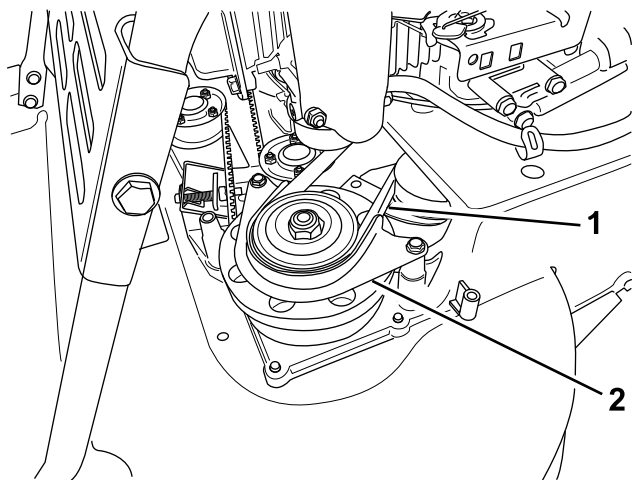

Figure 40

1. BBC belt
2. BBC belt guard

6. Remove the BBC belt from the front left-hand pulley.
7. Loosen the adjusting bolt (Figure 28).
8. Remove the fixed idler pulley and the hardware (Figure 41).

Note: Save the idler pulley and hardware for installation later.

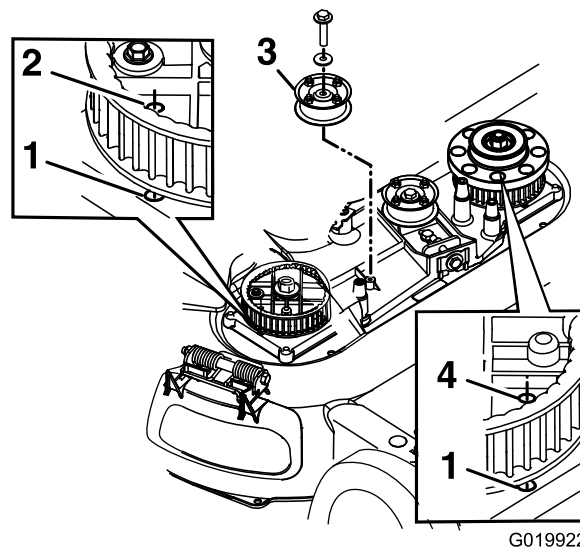

Figure 41

The BBC idler pulley is removed for clarity

1. Hole in the housing
2. Right-hand sprocket hole
3. Fixed-idler pulley
4. Left-hand sprocket hole

9. Remove the blade-drive belt.
 10. Align the holes in the right-hand and left-hand sprockets with the holes in the housing as shown in Figure 41.
- Note:** Hold the sprockets in place with a rod or a screwdriver.
11. When you have locked the sprockets in place, install the blade-drive belt and the fixed idler pulley.
- Note:** Ensure that the teeth are engaged in the sprockets.
12. Tighten the belt tension to the recommended settings; refer to .
 13. Remove the rod or screwdriver from the sprockets.
 14. Ensure that the blades under the housing are properly aligned; refer to Servicing the Cutting Blades (page 20).
 15. Install the BBC belt and the BBC belt guard and hardware.
 16. Install the belt cover using the 4 bolts that you removed in step 3.
 17. Connect the wire to the spark plug.
 18. Check the operation of the control bar and the blade-brake clutch.

Cleaning under the Machine Housing

For optimal cutting performance, keep the underside of the machine housing clean. You may either wash or scrape the clippings away from under the machine housing.

Washing under the Machine Housing

Service Interval: Before each use or daily—Clean under the machine housing.

1. Position the machine on a flat concrete or asphalt surface near a garden hose.
2. Start the engine.
3. Hold the running garden hose at handle level and direct the water to flow on the ground just in front of the right rear tire (Figure 42).

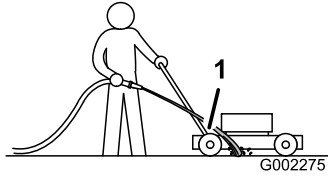

Figure 42

1. Right rear wheel

Note: The blades will draw in water and wash out clippings. Let the water run until you no longer see clippings being washed out from under the housing.

4. Stop the engine and wait for all moving parts to stop.
5. Turn off the water.
6. Start the machine and let it run for a few minutes to dry out the moisture on the machine and its components.

Scraping under the Machine Housing

If washing does not remove all debris from under the machine, scrape it clean.

1. Disconnect the wire from the spark plug.
2. Drain the fuel from the fuel tank; refer to Emptying the Fuel Tank and Cleaning the Filter (page 19).

⚠ WARNING

Tipping the machine may cause the fuel to leak from the carburetor or the fuel tank. Gasoline is extremely flammable, highly explosive, and, under certain conditions, can cause personal injury or property damage.

Avoid fuel spills by running the engine dry or by removing the gasoline with a hand pump; never siphon.

3. Tip the machine onto its side, with the air filter up in the air, until the upper handle rests on the ground.
4. Remove the dirt and grass clippings with a hardwood scraper; avoid burrs and sharp edges.
5. Turn the machine upright.
6. Fill the fuel tank.
7. Connect the wire to the spark plug.

Storage

Store the machine in a cool, clean, dry place. Cover the machine to keep it clean and protected.

General Information

Store the machine in a cool, clean, dry place. Cover the machine to keep it clean and protected.

1. Perform the recommended annual maintenance procedures; refer to Maintenance (page 16).
2. Clean under the machine housing; refer to Cleaning under the Machine Housing (page 24).
3. Remove chaff, dirt, and grime from the external parts of the engine, the shrouding, and the top of the machine.
4. Check the condition of the blades; refer to Inspecting the Blades (page 20).
5. Service the air filter; refer to Servicing the Air Filter (page 16).
6. Tighten all nuts, bolts, and screws.
7. Touch up all rusted or chipped paint surfaces with paint available from an Authorized Service Dealer.

Preparing the Fuel System

⚠ WARNING

Gasoline can vaporize if you store it over long periods of time and explode if it comes into contact with an open flame.

- Do not store gasoline over long periods of time.
- Do not store the machine with gasoline in the fuel tank or the carburetor in an enclosure with an open flame. (For example, a furnace or a water heater pilot light.)
- Allow the engine to cool before storing it in any enclosure.

On the last refueling of the year, add fuel stabilizer to the fuel as directed by the engine manufacturer. Empty the fuel tank when mowing the last time before storing the machine.

1. Run the machine until the engine stops from running out of fuel.
2. Start the engine again.
3. Allow the engine to run until it stops. When you can no longer start the engine, it is sufficiently dry.

Preparing the Engine

1. While the engine is still warm, change the engine oil and the oil filter; refer to Changing the Engine Oil (page 17) and Changing the Oil Filter (page 18).
2. Remove the spark plug.
3. Using an oil can, add about 30 ml (1 oz), of motor oil to the engine through the spark-plug hole.
4. Slowly pull the starter rope several times to distribute oil throughout the cylinder.
5. Install the spark plug but do not connect the wire to the spark plug. Secure the wire so that it does not come into contact with the spark plug.

Removing the Machine from Storage

1. Check and tighten all fasteners.
2. Remove the spark plug and spin the engine rapidly using the starter to blow excess oil from the cylinder.
3. Inspect the spark plug and replace it if it is dirty, worn, or cracked; refer to the engine operator's manual.
4. Install the spark plug and tighten it to the recommended torque of 20 N-m (180 in-lb).
5. Perform any needed maintenance procedures; refer to Maintenance (page 16).
6. Check the engine oil level; refer to Checking the Engine Oil Level (page 9).
7. Fill the fuel tank with fresh gasoline; refer to Filling the Fuel Tank with Gasoline (page 9).
8. Connect the wire to the spark plug.

Troubleshooting

Problem	Possible Cause	Corrective Action
The engine does not start.	<ol style="list-style-type: none"> 1. The fuel tank is empty or the fuel system contains stale fuel. 2. The fuel shutoff valve is closed. 3. The throttle lever is not in the correct position. 4. There is dirt, water, or stale fuel in the fuel system. 5. The wire is not connected to the spark plug. 6. The spark plug is pitted, fouled, or the gap is incorrect. 7. There is dirt in the fuel filter. 	<ol style="list-style-type: none"> 1. Drain and/or fill the fuel tank with fresh gasoline. If the problem persists, contact an Authorized Service Dealer. 2. Open the fuel shutoff valve. 3. Move the throttle lever to the Choke position. 4. Contact an Authorized Service Dealer. 5. Connect the wire to the spark plug. 6. Check the spark plug and adjust the gap if necessary. Replace the spark plug if it is pitted, fouled, or cracked. 7. Replace the fuel filter and clean the in-tank filter screen.
The engine starts hard or loses power.	<ol style="list-style-type: none"> 1. The air filter element is dirty and is restricting the air flow. 2. The engine oil level is low or the oil is dirty. 3. The fuel tank vent hose is plugged. 4. There is dirt in the fuel filter. 5. There is dirt, water, or stale fuel in the fuel system. 6. The underside of the machine housing contains clippings and debris. 7. The spark plug is pitted, fouled, or the gap is incorrect. 	<ol style="list-style-type: none"> 1. Clean the air filter pre-cleaner and/or replace the paper filter. 2. Check the engine oil. Change the oil if it is dirty or add oil if it is low. 3. Clean or replace the fuel tank vent hose. 4. Replace the fuel filter and clean the in-tank filter screen. 5. Contact an Authorized Service Dealer. 6. Clean the underside of the machine housing. 7. Check the spark plug and adjust the gap if necessary. Replace the spark plug if it is pitted, fouled, or cracked.
The engine runs rough.	<ol style="list-style-type: none"> 1. The wire is not securely connected to the spark plug. 2. The spark plug is pitted, fouled, or the gap is incorrect. 3. The throttle lever is not in the Fast position. 4. The air filter element is dirty and is restricting the air flow. 5. There is dirt in the fuel filter. 	<ol style="list-style-type: none"> 1. Connect the wire securely to the spark plug. 2. Check the spark plug and adjust the gap if necessary. Replace the spark plug if it is pitted, fouled, or cracked. 3. Move the throttle lever to the Fast position. 4. Clean the air filter pre-cleaner and/or replace the paper filter. 5. Replace the fuel filter and clean the in-tank filter screen.
The machine or engine vibrates excessively.	<ol style="list-style-type: none"> 1. A blade is bent or is out of balance. 2. A blade-mounting bolt is loose. 3. The underside of the machine housing contains clippings and debris. 4. The engine mounting bolts are loose. 5. The engine pulley, idler pulley, or blade pulley are loose. 6. The engine pulley is damaged. 7. The blade spindle is bent. 8. The belt is damaged. 	<ol style="list-style-type: none"> 1. Balance the blade(s). If a blade is bent, replace it. 2. Tighten the blade-mounting bolts. 3. Clean the underside of the machine housing. 4. Tighten the engine mounting bolts. 5. Tighten the loose pulley. 6. Contact an Authorized Service Dealer. 7. Contact an Authorized Service Dealer. 8. Replace the belt.

Problem	Possible Cause	Corrective Action
There is an uneven cutting pattern.	<ol style="list-style-type: none"> 1. All 4 wheels are not at the same height. 2. The blades are dull. 3. You are mowing in the same pattern repeatedly. 4. The underside of the machine housing contains clippings and debris. 5. The blade spindle is bent. 	<ol style="list-style-type: none"> 1. Place all 4 wheels at the same height. 2. Sharpen and balance the blades. 3. Change the mowing pattern. 4. Clean the underside of the machine housing. 5. Contact an Authorized Service Dealer.
The discharge chute gets plugged up.	<ol style="list-style-type: none"> 1. The throttle lever is not in the Fast position. 2. The cutting height is too low. 3. You are mowing too fast. 4. The grass is wet. 5. The underside of the machine housing contains clippings and debris. 	<ol style="list-style-type: none"> 1. Move the throttle lever to the Fast position. 2. Raise the cutting height; if necessary, mow a second time at a lower cutting height. 3. Slow down. 4. Allow the grass to dry before mowing. 5. Clean the underside of the machine housing.
The machine does not self-propel.	<ol style="list-style-type: none"> 1. The self-propel drive cable is out of adjustment or is damaged. 2. There is debris in the belt area. 3. The belt is damaged. 	<ol style="list-style-type: none"> 1. Adjust the self-propel drive cable; replace the cable if necessary. 2. Clean the debris from the belt area. 3. Replace the belt.
The blades do not rotate or they slip.	<ol style="list-style-type: none"> 1. The BBC belt or the timing belt is worn, loose, or broken. 2. The BBC belt is off the pulley. 3. The BBC cable is worn, loose, or broken. 	<ol style="list-style-type: none"> 1. Adjust the BBC cable; adjust the timing belt tension; replace them if necessary. 2. Check the belt for damage, and replace it if necessary. 3. Adjust the BBC cable; replace it if necessary.
The blades contact each other.	<ol style="list-style-type: none"> 1. The blades are installed or aligned incorrectly. 2. The blade adapters are worn, loosen, or broken. 3. The timing belt or worn, loose, or broken. 4. The timing sprockets or idler pulley is worn, loose, or broken. 	<ol style="list-style-type: none"> 1. Install the blades properly. 2. Replace the blade adapters. 3. Re-time the blades and adjust the timing belt tension, replace it if necessary. 4. Replace the sprockets or the idler pulley if necessary.

Notes:

Notes:

International Distributor List

Distributor:	Country:	Phone Number:	Distributor:	Country:	Phone Number:
Agrolanc Kft	Hungary	36 27 539 640	Maquiver S.A.	Colombia	57 1 236 4079
Balama Prima Engineering Equip.	Hong Kong	852 2155 2163	Maruyama Mfg. Co. Inc.	Japan	81 3 3252 2285
B-Ray Corporation	Korea	82 32 551 2076	Mountfield a.s.	Czech Republic	420 255 704 220
Casco Sales Company	Puerto Rico	787 788 8383	Mountfield a.s.	Slovakia	420 255 704 220
Ceres S.A.	Costa Rica	506 239 1138	Munditol S.A.	Argentina	54 11 4 821 9999
CSSC Turf Equipment (pvt) Ltd.	Sri Lanka	94 11 2746100	Norma Garden	Russia	7 495 411 61 20
Cyril Johnston & Co.	Northern Ireland	44 2890 813 121	Oslinger Turf Equipment SA	Ecuador	593 4 239 6970
Cyril Johnston & Co.	Republic of Ireland	44 2890 813 121	Oy Hako Ground and Garden Ab	Finland	358 987 00733
Equivier	Mexico	52 55 539 95444	Parkland Products Ltd.	New Zealand	64 3 34 93760
Femco S.A.	Guatemala	502 442 3277	Perfetto	Poland	48 61 8 208 416
ForGarder OU	Estonia	372 384 6060	Pratoverde SRL.	Italy	39 049 9128 128
G.Y.K. Company Ltd.	Japan	81 726 325 861	Prochaska & Cie	Austria	43 1 278 5100
Geomechaniki of Athens	Greece	30 10 935 0054	RT Cohen 2004 Ltd.	Israel	972 986 17979
Golf international Turizm	Turkey	90 216 336 5993	Riversa	Spain	34 9 52 83 7500
Guandong Golden Star	China	86 20 876 51338	Lely Turfcare	Denmark	45 66 109 200
Hako Ground and Garden	Sweden	46 35 10 0000	Solvvert S.A.S.	France	33 1 30 81 77 00
Hako Ground and Garden	Norway	47 22 90 7760	Spypros Stavrinides Limited	Cyprus	357 22 434131
Hayter Limited (U.K.)	United Kingdom	44 1279 723 444	Surge Systems India Limited	India	91 1 292299901
Hydroturf Int. Co Dubai	United Arab Emirates	97 14 347 9479	T-Markt Logistics Ltd.	Hungary	36 26 525 500
Hydroturf Egypt LLC	Egypt	202 519 4308	Toro Australia	Australia	61 3 9580 7355
Irrimac	Portugal	351 21 238 8260	Toro Europe NV	Belgium	32 14 562 960
Irrigation Products Int'l Pvt Ltd.	India	0091 44 2449 4387	Valtech	Morocco	212 5 3766 3636
Jean Heybroek b.v.	Netherlands	31 30 639 4611	Victus Emak	Poland	48 61 823 8369

European Privacy Notice

The Information Toro Collects

Toro Warranty Company (Toro) respects your privacy. In order to process your warranty claim and contact you in the event of a product recall, we ask you to share certain personal information with us, either directly or through your local Toro company or dealer.

The Toro warranty system is hosted on servers located within the United States where privacy law may not provide the same protection as applies in your country.

BY SHARING YOUR PERSONAL INFORMATION WITH US, YOU ARE CONSENTING TO THE PROCESSING OF YOUR PERSONAL INFORMATION AS DESCRIBED IN THIS PRIVACY NOTICE.

The Way Toro Uses Information

Toro may use your personal information to process warranty claims, to contact you in the event of a product recall and for any other purpose which we tell you about. Toro may share your information with Toro's affiliates, dealers or other business partners in connection with any of these activities. We will not sell your personal information to any other company. We reserve the right to disclose personal information in order to comply with applicable laws and with requests by the appropriate authorities, to operate our systems properly or for our own protection or that of other users.

Retention of your Personal Information

We will keep your personal information as long as we need it for the purposes for which it was originally collected or for other legitimate purposes (such as regulatory compliance), or as required by applicable law.

Toro's Commitment to Security of Your Personal Information

We take reasonable precautions in order to protect the security of your personal information. We also take steps to maintain the accuracy and current status of personal information.

Access and Correction of your Personal Information

If you would like to review or correct your personal information, please contact us by email at legal@toro.com.

Australian Consumer Law

Australian customers will find details relating to the Australian Consumer Law either inside the box or at your local Toro Dealer.



The Toro Warranty and The Toro GTS Starting Guarantee

Residential Products

Conditions and Products Covered

The Toro Company and its affiliate, Toro Warranty Company, pursuant to an agreement between them, jointly promise to repair for the original purchaser¹ the Toro Product listed below if defective in materials or workmanship or if the Toro GTS (Guaranteed to Start) engine will not start on the first or second pull, provided the routine maintenance required in the *Operator's Manual* have been performed.

The following time periods apply from the date of purchase:

Products	Warranty Period
Walk Power Mowers	
• Cast Deck	5 years Residential Use ² 90 Days Commercial Use
• Engine	5 years GTS Guarantee, Residential Use ³
• Battery	2 years
• Steel Deck	2 years Residential Use ² 30 Days Commercial Use
• Engine	2 years GTS Guarantee, Residential Use ³
TimeMaster Mowers	
• Engine	3 years Residential Use ² 90 Days Commercial Use
• Battery	3 years GTS Guarantee, Residential Use ³
• Battery	2 years
Electric Hand Held Products	2 years Residential Use ² No Warranty for Commercial Use
Snowthrowers	
• Single Stage	2 years Residential Use ² 45 Days Commercial Use
• Engine	2 years GTS Guarantee, Residential Use ³
• Two Stage	3 years Residential Use ² 45 Days Commercial Use
• Chute, chute deflector and impeller housing cover	Lifetime (original owner only) ⁵
Electric Snowthrowers	2 years Residential Use ² No Warranty for Commercial Use
All Ride-On Units Below	
• Engine	See engine manufacturer's warranty ⁴
• Battery	2 years Residential Use ²
• Attachments	2 years Residential Use ²
DH Lawn & Garden Tractors	2 years Residential Use ² 30 Days Commercial Use
XLS Lawn & Garden Tractors	3 years Residential Use ² 30 Days Commercial Use
TimeCutter	3 years Residential Use ² 30 Days Commercial Use
TITAN Mowers	
• Frame	3 years or 240 hours ⁵ Lifetime (original owner only) ⁶

¹Original Purchaser means the person who originally purchased the Toro Product.

²Residential use means use of the product on the same lot as your home. Use at more than one location is considered commercial use and the commercial use warranty would apply.

³The Toro GTS Starting Guarantee does not apply when the product is used commercially.

⁴Some engines used on Toro Products are warranted by the engine manufacturer.

⁵Whichever occurs first.

⁶Lifetime Frame Warranty - If the main frame, consisting of the parts welded together to form the tractor structure that other components such as the engine are secured to, cracks or breaks in normal use, it will be repaired or replaced, at Toro's option, under warranty at no cost for parts and labor. Frame failure due to misuse or abuse and failure or repair required due to rust or corrosion are not covered.

Warranty may be denied if the hour meter is disconnected, altered, or shows signs of being tampered with.

Owner Responsibilities

You must maintain your Toro Product by following the maintenance procedures described in the *Operator's Manual*. Such routine maintenance, whether performed by a dealer or by you, is at your expense.

Instructions for Obtaining Warranty Service

If you think that your Toro Product contains a defect in materials or workmanship, follow this procedure:

1. Contact your seller to arrange service of the product. If for any reason it is impossible for you to contact your seller, you may contact any Toro Authorized Distributor to arrange service. See attached Distributor List.
2. Bring the product and your proof of purchase (sales receipt) to the servicing outlet. If for any reason you are dissatisfied with the servicing outlet's analysis or with the assistance provided, contact us at:

Toro Customer Care Department, RLC Division
Toro Warranty Company
8111 Lyndale Avenue South
Bloomington, MN 55420-1196
001-952-948-4707

Items and Conditions Not Covered

There is no other express warranty except for special emission system coverage and engine warranty coverage on some products. This express warranty does not cover the following:

- Cost of regular maintenance service or parts, such as filters, fuel, lubricants, oil changes, spark plugs, air filters blade sharpening or worn blades, cable/linkage adjustments, or brake and clutch adjustments
- Components failing due to normal wear
- Any product or part which has been altered or misused or neglected and requires replacement or repair due to accidents or lack of proper maintenance
- Pickup and delivery charges
- Repairs or attempted repairs by anyone other than an Authorized Toro Service Dealer
- Repairs necessary due to failure to follow recommended fuel procedure (consult *Operator's Manual* for more details)
 - Removing contaminants from the fuel system is not covered
 - Use of old fuel (more than one month old) or fuel which contains more than 10% ethanol or more than 15% MTBE
 - Failure to drain the fuel system prior to any period of non-use over one month
- Repairs or adjustments to correct starting difficulties due to the following:
 - Failure to follow proper maintenance procedures or recommended fuel procedure
 - Rotary mower blade striking an object
- Special operational conditions where starting may require more than two pulls:
 - First time starts after extended period of non-use over three months or seasonal storage
 - Cool temperature starts such as those found in early spring and late autumn
 - Improper starting procedures - if you are having difficulty starting your unit, please check the *Operator's Manual* to ensure that you are using the correct starting procedures. This can save an unnecessary visit to an Authorized Toro Service Dealer.

General Conditions

The purchaser is covered by the national laws of each country. The rights to which the purchaser is entitled with the support of these laws are not restricted by this warranty.