



Count on it.

Parts Catalog

22in Recycler® Lawn Mower

Model No. 20332—Serial No. 314000001 and Up



Ordering Replacement Parts

To order replacement parts, please supply the part number, the quantity, and the description of each part desired.

Understanding Reference Numbers

Each identified part in an illustration has a reference number. The reference number for a part also appears in the parts list, along with other information about the part.

This catalog uses two special reference number formats, one to indicate parts in a service assembly and another to indicate the quantity of a given part in an illustration.

Service Assembly Reference Numbers

Parts in service assemblies have reference numbers in the form a:b. The a represents the reference number of the entire service assembly and the b represents a sequential number unique to each part within the service assembly.

For example, a wheel assembly might be identified by reference number 6, the tire by 6:1, the valve by 6:2, and the wheel by 6:3. When you order the assembly identified by reference number 6, you receive all parts identified by reference numbers 6:1, 6:2, and 6:3. However, you may also order any part individually. Reference numbers of this type appear in illustration and in parts lists.

Reference Numbers Indicating Quantity

In an illustration, if a reference number indicates more than one part, the reference number has the form nX y. The n represents the quantity of the part, the X is the multiplication symbol, and the y represents the reference number.

For example, in an illustration, the reference number 2X 37 means that two of the parts identified by reference number 37 are indicated.

List of Abbreviations

AR: as required	HLH: hex lag head	PTO: power-take-off
ASM: assembly	HOC: height-of-cut	RH: right hand
BBC: blade brake control	HSBH: hex socket button head	ROPS: roll-over protection system
BHTF: button head thread forming	HSFH: hex socket flat head	RRB: rear roller brush
CARR: carriage	HSH: hex socket head	SFH: slotted fillister head
CCW: counter clockwise	HWH: hex washer head	SHH: slotted hex head
CW: clockwise	HWHTF: hex washer head thread forming	SHWH: slotted hex washer head
DEG: degrees	HYD: hydraulic	SPH: slotted pan head
DPA: Dual Point Adjustment	LH: left hand	SQH: square head
ECM: electronic control module	LP: Liquefied Petroleum Gas	SRH: slotted round head
EXT: external	LPG: Liquefied Petroleum Gas	STD: standard
FH: flat head	NI: nylon insert	TAP: self tapping
GA: gauge	NPTF: national pipe thread fine	TTH: torx truss head
HD: heavy-duty	PFH: phillips flat head	
HF: hex flange	PPH: phillips pan head	
HH: hex head	PPHTF: phillips pan head thread forming	
HHF: hex head flange	PRH: phillips round head	
HHFTF: hex head flange thread forming	PTH: phillips truss head	
HJ: hex jam		

Contents

Deck, Side Chute and Rear Door Assembly	4
Rear Bag Assembly	6
Engine and Blade Assembly	8
Front Wheel and Height-of-Cut Assembly	10
Transmission and Rear Wheel Drive Assembly	12
Handle Assembly	14
Attachments and Accessories	16

Deck, Side Chute and Rear Door Assembly

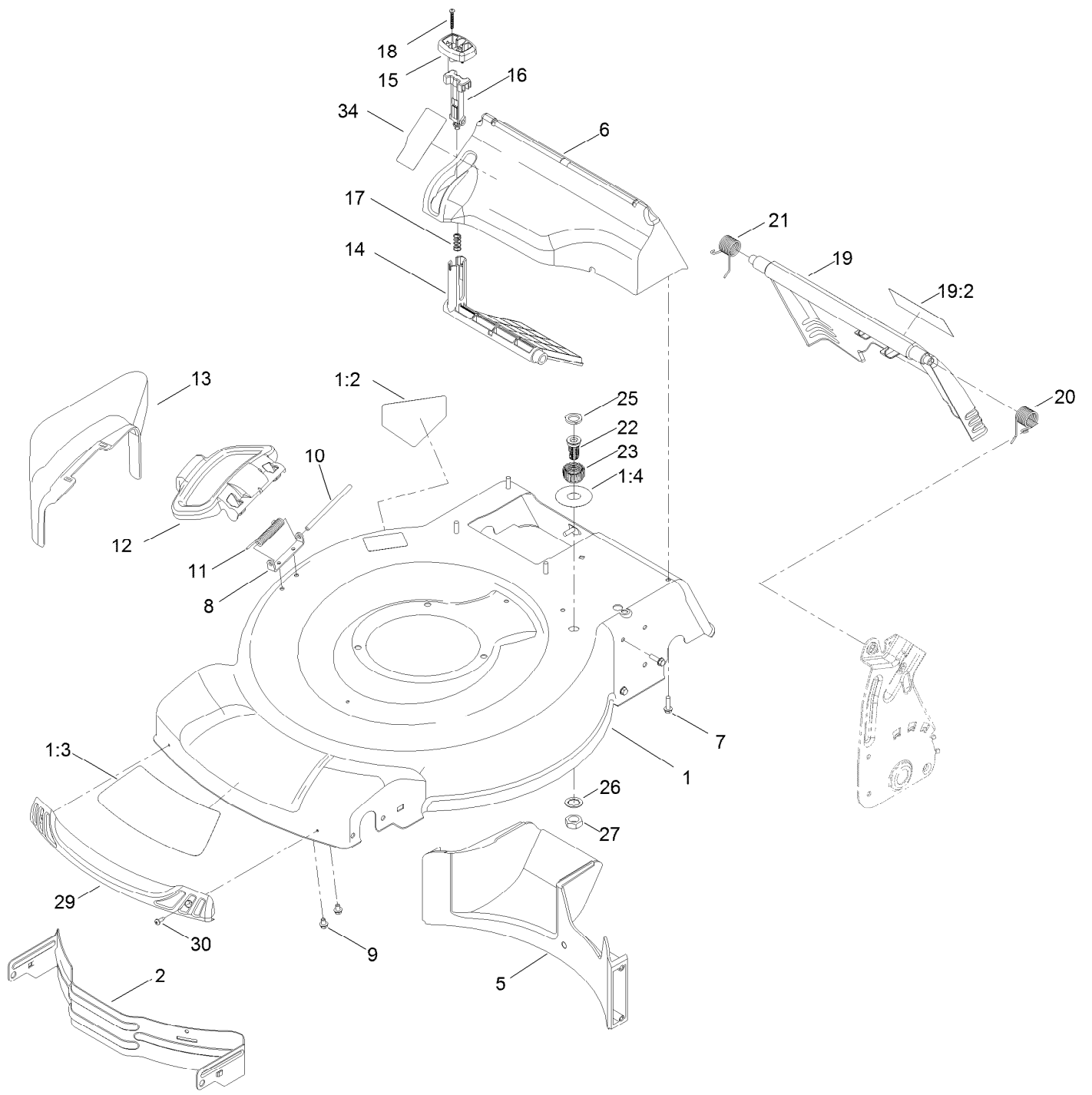

Deck, Side Chute and Rear Door Assembly (continued)

<i>Ref.</i>	<i>Part Number</i>	<i>Qty.</i>	<i>Description</i>	<i>Ref.</i>	<i>Part Number</i>	<i>Qty.</i>	<i>Description</i>
1	130-2389	1	Housing ASM	16	114-7959	1	Latch-Recycle
1:2	94-8072	1	Decal-Danger	17	117-1031	1	Spring-Compression
1:3	115-4676	1	Decal-Recycler	18	32104-120	2	Screw-PPH
1:4	112-8867	1	Decal-Washout Port	19	121-5776	1	Rear Door ASM
2	114-7963-01	1	Baffle-Front	19:2	114-7982	1	Decal-Warning
5	114-7961	1	Baffle-Rear	20	115-2859	1	Spring-Torsion
6	115-4677	1	Chute-Recycle	21	114-7924	1	Spring-Torsion
7	46-8091	9	Screw-HWH	22	112-6400	1	Port-Washout
8	112-6416	1	Bracket-Cover	23	112-6401	1	Coupling-Hose, Washout Port
9	99-8445	2	Screw-HWH	25	112-6438	1	Washer-Seal, Washout Port
10	99-5291	1	Rod-Cover	26	3254-5	1	Washer-Tooth, Internal
11	99-5293	1	Spring-Torsion	27	3218-6	1	Nut-Jam
12	115-8449	1	Deflector-Side	29	114-7987	1	Bumper
13	115-8447	1	Chute-Discharge, Side	30	105-6849	2	Screw-Thread Forming
14	114-7960	1	Deflector-Recycle	34	125-5026	1	Decal-Bag On Demand
15	114-7958	1	Knob-Recycle				

Rear Bag Assembly

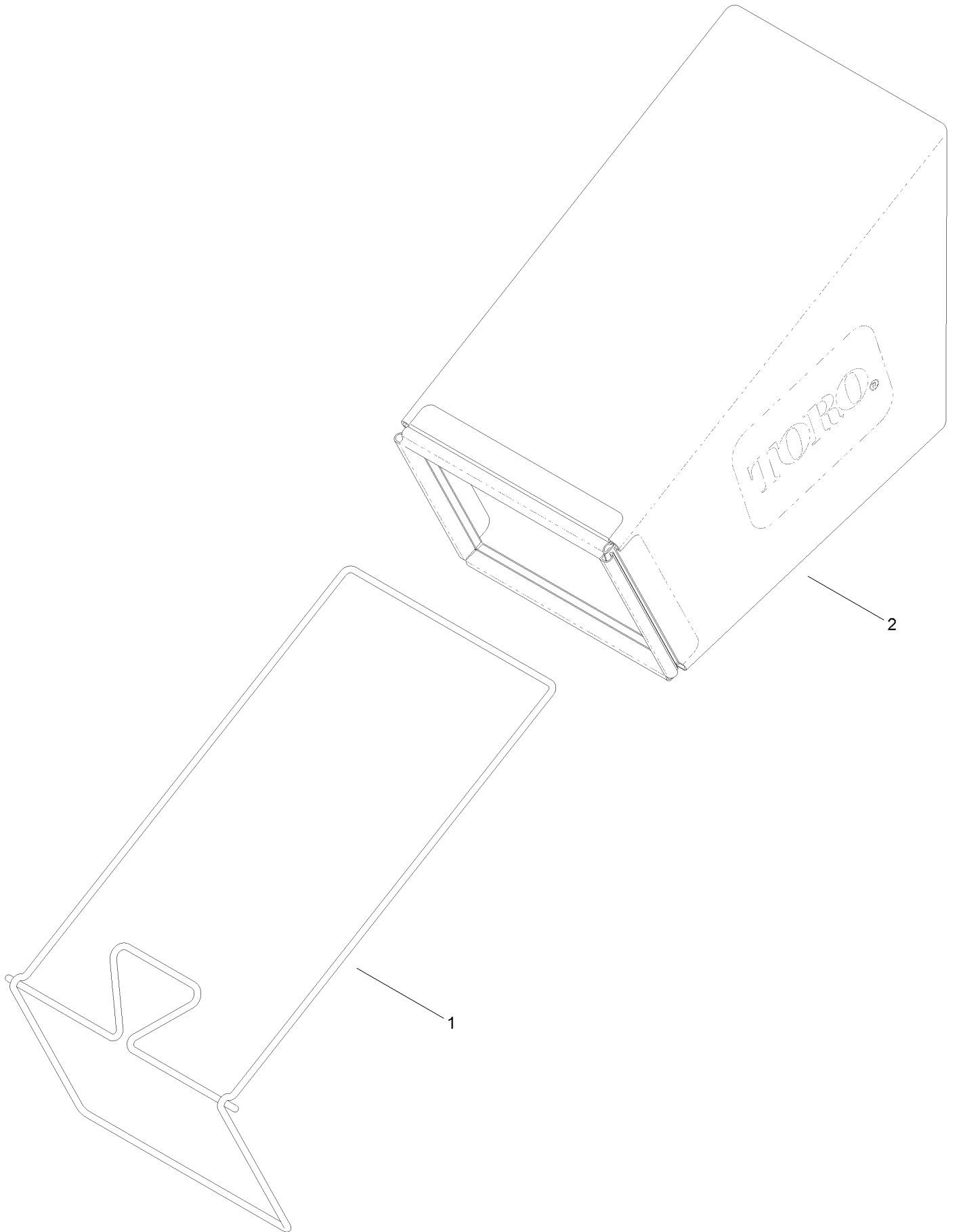

Rear Bag Assembly (continued)

<i>Ref.</i>	<i>Part Number</i>	<i>Qty.</i>	<i>Description</i>
1	114-2679-03	1	Frame-Bag
2	115-4673	1	Grass Bag ASM

Engine and Blade Assembly

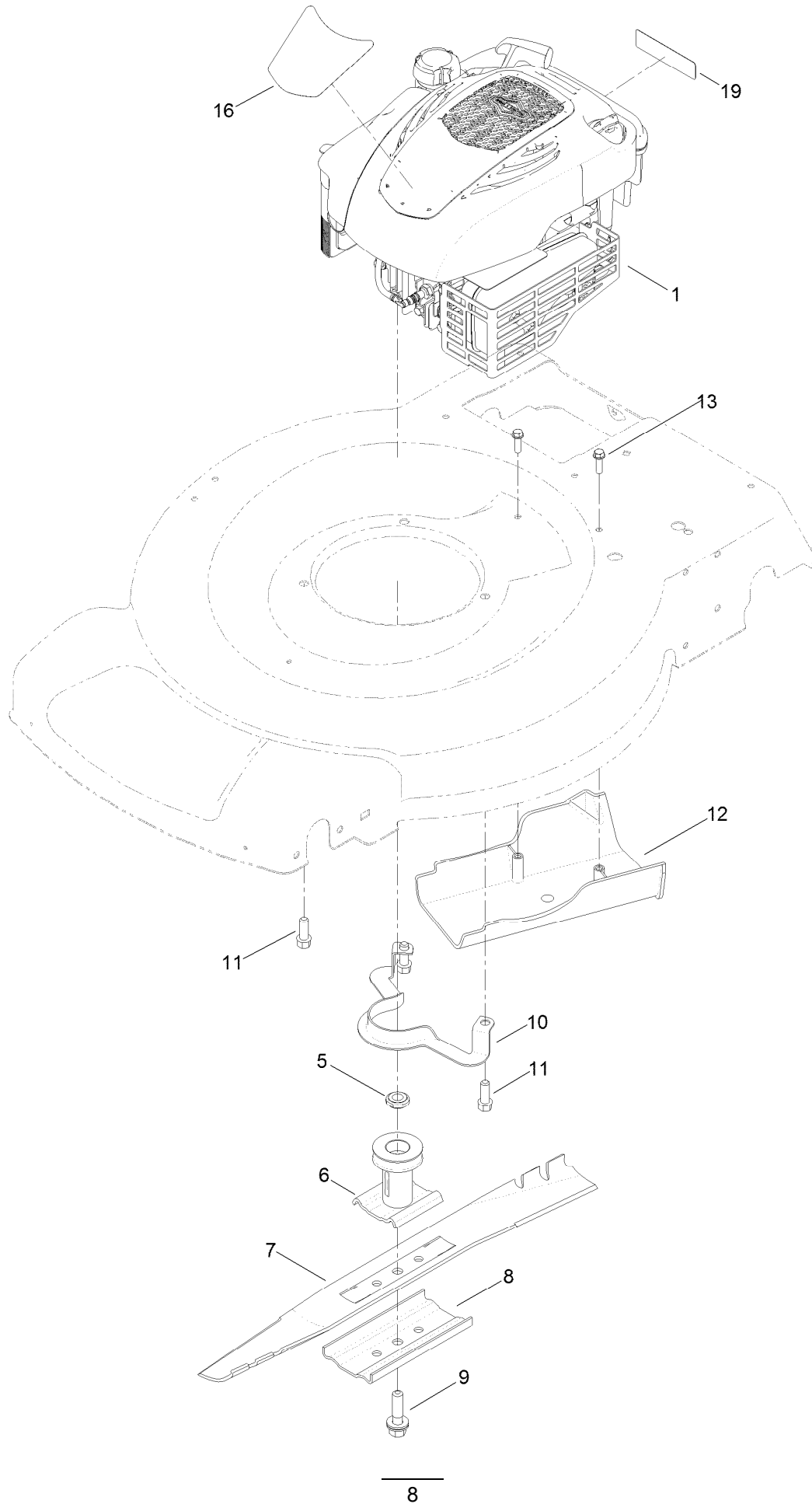

Engine and Blade Assembly (continued)

<i>Ref.</i>	<i>Part Number</i>	<i>Qty.</i>	<i>Description</i>	<i>Ref.</i>	<i>Part Number</i>	<i>Qty.</i>	<i>Description</i>
1		1	Engine-Briggs, 128M02-0133-F1 ●■	10	105-3030-03	1	Guide-Belt
5	106-3999	1	Spacer-Driver	11	95-1726	3	Screw-Taptite
6	106-3987	1	Driver-Blade	12	114-7937	1	Cover-Belt
7	108-9764-03	1	Blade-22 Inch	13	46-8091	2	Screw-HWH
8	108-3766-03	1	Support-Blade	16	121-2371	1	Decal-Shroud
9	125-2466	1	Bolt-Blade	19	117-2718	1	Decal-Arrester, Spark

● Not serviced separately

■ Obtain parts from www.briggsandstratton.com

Front Wheel and Height-of-Cut Assembly

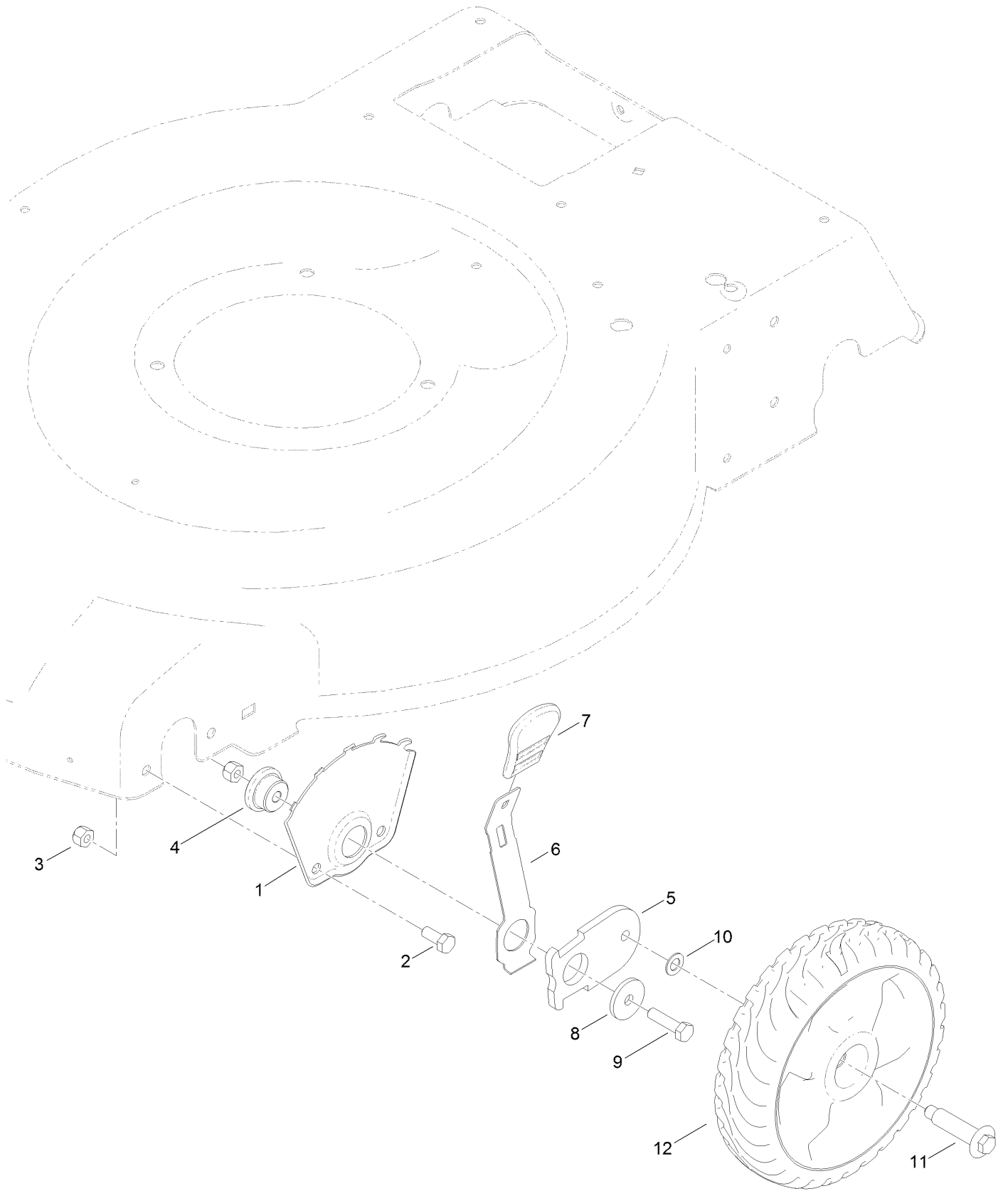

Front Wheel and Height-of-Cut Assembly (continued)

<i>Ref.</i>	<i>Part Number</i>	<i>Qty.</i>	<i>Description</i>	<i>Ref.</i>	<i>Part Number</i>	<i>Qty.</i>	<i>Description</i>
1	115-1956-03	2	Plate-HOC, Front	7	110-0549	2	Knob-HOC
2	322-3	4	Screw-HH	8	105-3048	2	Washer-Flat
3	3296-29	6	Nut-Lock, NI	9	322-6	2	Screw-HH
4	105-1818	2	Bushing-Mount, HOC	10	40-1940	2	Washer
5	105-1807	2	Arm-Pivot, Front	11	614650	2	Bolt-Shoulder
6	105-1809	2	Arm-Spring	12	115-2894	2	8 Inch Wheel ASM

Transmission and Rear Wheel Drive Assembly

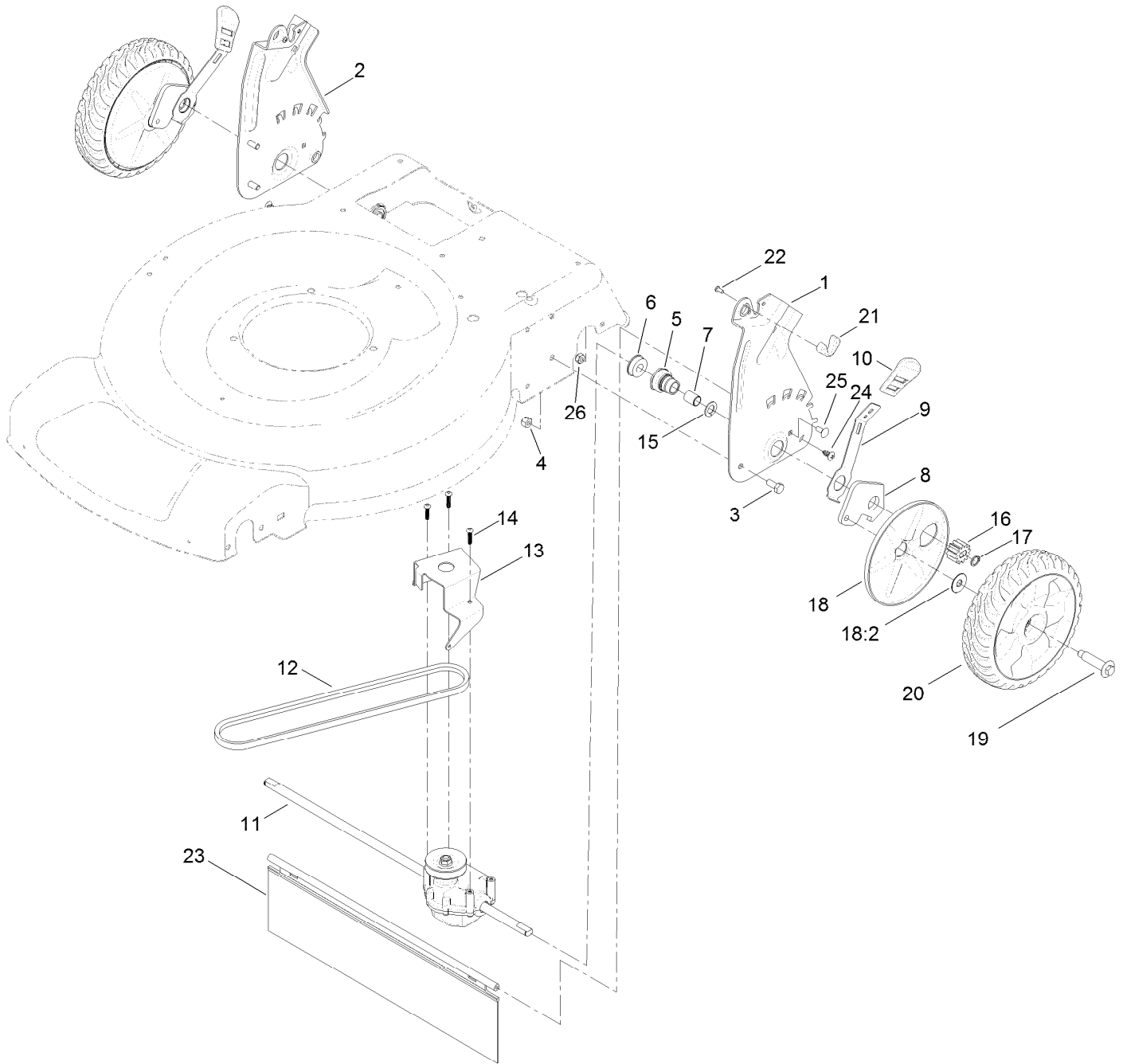

Transmission and Rear Wheel Drive Assembly (continued)

<i>Ref.</i>	<i>Part Number</i>	<i>Qty.</i>	<i>Description</i>	<i>Ref.</i>	<i>Part Number</i>	<i>Qty.</i>	<i>Description</i>
1	127-6877-03	1	Plate-Rear, LH (HOC)	15	110-7191	2	Washer-Thrust
2	127-6878-03	1	Plate-Rear, RH (HOC)	16	110-9417	2	Gear-Pinion, 15T
3	322-3	4	Screw-HH	17	32151-61	2	Ring-Retaining
4	3296-29	4	Nut-Lock, NI	18	110-1792	2	Wheel Cover ASM
5	108-9779	2	Retainer-Bushing, HOC	18:2	614426	1	Washer-Stepped
6	104-8699	2	Bearing-Ball	19	614650	2	Bolt-Shoulder
7	108-9782	2	Bushing-Sleeve	20	119-3822	2	8 Inch Wheel Gear ASM
8	108-9781	2	Arm-Pivot, Rear	21	115-8406	2	Anchor-Bag
9	108-9780	2	Arm-Spring	22	105-9437	2	Screw-PPH
10	110-0549	2	Knob-HOC	23	120-7012	1	Shield-Trailing
11	121-9178	1	Transmission	24	117-1092	2	Screw-PTH
12	115-4669	1	Belt-V	25	3229-11	2	Screw-CARR
13	114-7977-03	1	Bracket-Transmission	26	3296-16	2	Nut-Lock, NI
14	108-7476	3	Screw-Plastite				

Handle Assembly

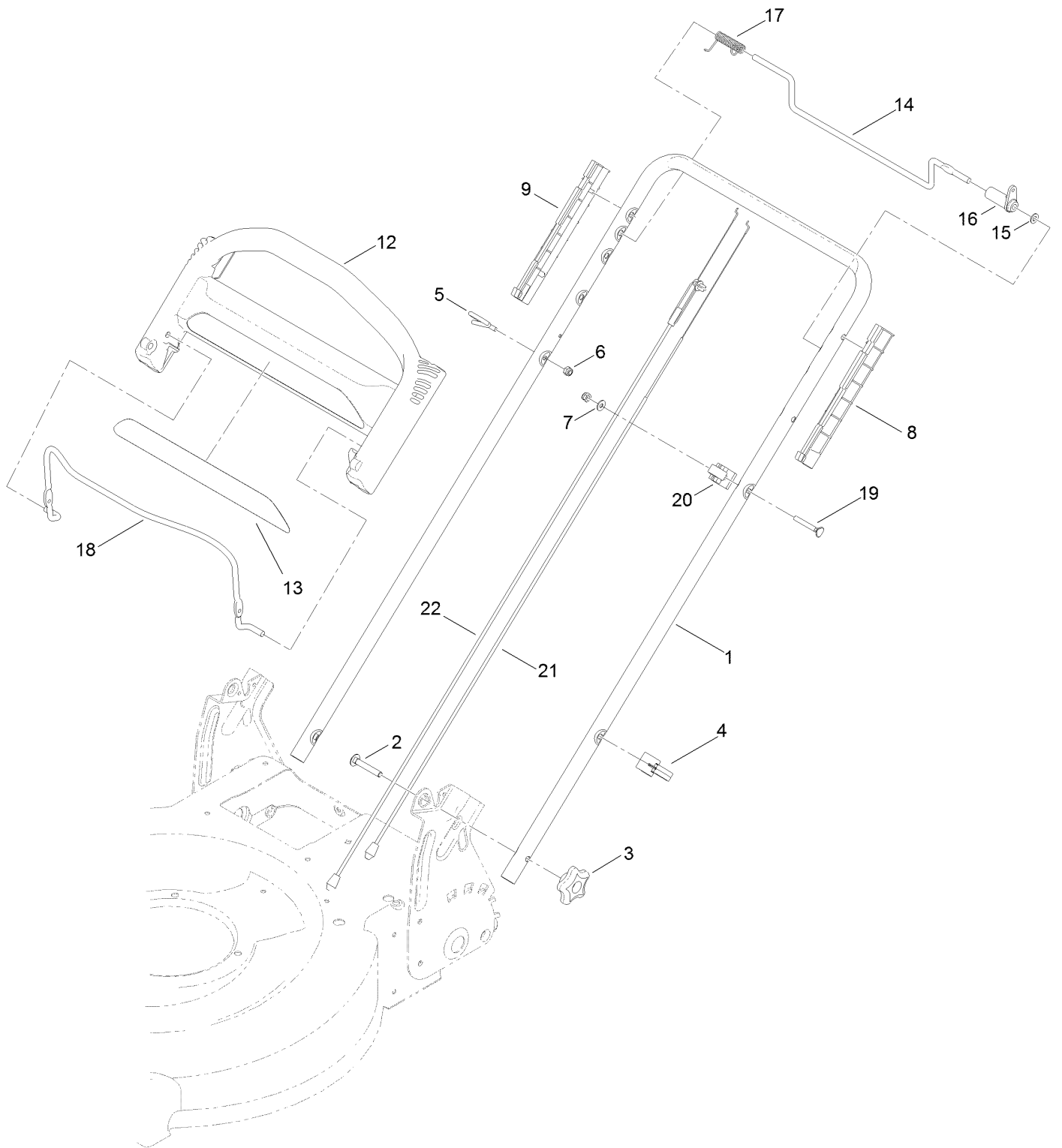

Handle Assembly (continued)

<i>Ref.</i>	<i>Part Number</i>	<i>Qty.</i>	<i>Description</i>	<i>Ref.</i>	<i>Part Number</i>	<i>Qty.</i>	<i>Description</i>
1	119-3810-05	1	Handle	13	117-1019	1	Decal
2	3230-6	2	Screw-CARR	14	99-1588	1	Bar-Control, Traction
3	117-5976	2	Knob-Handle	15	3256-23	1	Washer-Flat
4	114-7988	1	Guide-Cable	16	99-1589	1	Lever-Traction
5	86-9671	1	Guide-Rope	17	121-9118	1	Spring-Torsion
6	3296-73	2	Nut-Lock, NI	18	104-8679-03	1	Bail-Brake
7	3256-1	1	Washer-Flat	19	95-4453	1	Screw
8	105-6842	1	Guide-LH	20	99-5239	1	Anchor-Cable
9	105-6841	1	Guide-RH	21	115-8435	1	Cable-Traction
12	104-8678	1	Handle-Control	22	115-8437	1	Cable-Brake

Attachments and Accessories

For 20332 22in Recycler Lawn Mower

Product Name	Model/Part
Traction Assist Handle Kit.....	108-8120
Loose Parts Kit	117-4124
Replacement Bag	59310
Replacement Frame and Bag Kit.....	59312
22in Atomic Blade.....	59534P

Notes:

Notes:

Notes:



Count on it.