



# 53cm Super Bagger Lawn Mower

Model No. 20897—Serial No. 314000001 and Up

## Operator's Manual

# Introduction

This rotary-blade, walk-behind lawn mower is intended to be used by residential homeowners. It is designed primarily for cutting grass on well-maintained lawns on residential properties. It is not designed for cutting brush or for agricultural uses.

Read this information carefully to learn how to operate and maintain your product properly and to avoid injury and product damage. You are responsible for operating the product properly and safely.

You may contact Toro directly at [www.Toro.com](http://www.Toro.com) for product and accessory information, help finding a dealer, or to register your product.

Whenever you need service, genuine Toro parts, or additional information, contact an Authorized Service Dealer or Toro Customer Service and have the model and serial numbers of your product ready. Figure 1 identifies the location of the model and serial numbers on the product.

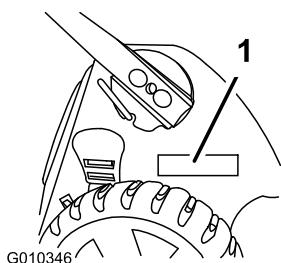

Figure 1

1. Model and serial number plate

Write the product model and serial numbers in the space below:

Model No. _____
Serial No. _____

This manual identifies potential hazards and has safety messages identified by the safety alert symbol (Figure 2), which signals a hazard that may cause serious injury or death if you do not follow the recommended precautions.



Figure 2

1. Safety alert symbol

This manual uses 2 words to highlight information.

**Important** calls attention to special mechanical information and **Note** emphasizes general information worthy of special attention.

This product complies with all relevant European directives. For details, see the separate product-specific Declaration of Conformity (DOC) sheet.

For models with stated engine horsepower, the gross horsepower of the engine was laboratory rated by the engine manufacturer in accordance with SAE J1940. As configured to meet safety, emission, and operating requirements, the actual engine horsepower on this class of lawn mower will be significantly lower.

Do not tamper with the engine controls or alter the governor speed; doing so may create an unsafe condition resulting in personal injury.

# Contents

Introduction .....	1
General Lawn Mower Safety .....	2
Sound Pressure .....	3
Sound Power .....	3
Hand/Arm Vibration .....	3
Safety and Instructional Decals .....	4
Setup .....	5
1 Unfolding the Handle.....	5
2 Installing the Recoil-starter Rope in the Rope Guide.....	5
3 Filling the Engine with Oil.....	6
4 Installing the Mulch Plug or the Grass Bag .....	6
Product Overview .....	8
Specifications .....	8
Operation .....	9
Filling the Fuel Tank .....	9
Checking the Engine Oil Level .....	9
Adjusting the Cutting Height.....	10
Starting the Engine .....	10
Using the Self-propel Drive.....	11
Engaging the Blade.....	11



Disengaging the Blade.....	11
Checking the Blade-stop System Operation.....	11
Stopping the Engine.....	12
Mulching the Clippings.....	12
Bagging the Clippings.....	12
Side-discharging the Clippings.....	14
Operating Tips.....	14
Maintenance.....	15
Recommended Maintenance Schedule(s).....	15
Preparing for Maintenance.....	15
Servicing the Air Filter.....	16
Changing the Engine Oil.....	16
Lubricating the Upper Handle.....	17
Adjusting the Self-propel Drive.....	18
Replacing the Blade.....	19
Cleaning the Blade-stop System Shield.....	19
Cleaning under the Machine Housing.....	20
Storage.....	20
Preparing the Machine for Storage.....	20
Folding the Handle.....	20
Removing the Machine from Storage.....	21

## Safety

Improperly using or maintaining this mower can result in injury. To reduce the potential for injury, comply with these safety instructions.

Toro designed and tested this machine for reasonably safe service; however, failure to comply with the following instructions may result in personal injury.

**To ensure maximum safety and best performance, and to gain knowledge of the product, it is essential that you and any other operator of the mower read and understand the contents of this manual before the engine is ever started. Pay particular attention to the safety alert symbol (Figure 2), which means Caution, Warning, or Danger—“personal safety instruction.” Read and understand the instruction because it has to do with safety. Failure to comply with the instruction may result in personal injury.**

## General Lawn Mower Safety

The following instructions have been adapted from EN 836.

This cutting machine is capable of amputating hands and feet and of throwing objects. Failure to observe the following safety instructions could result in serious injury or death.

### Training

- Read the instructions carefully. Be familiar with the controls and the proper use of the equipment.
- Never allow children or people unfamiliar with these instructions to use the mower. Local regulations can restrict the age of the operator.

- Keep in mind that the operator or user is responsible for accidents or hazards occurring to other people or their property.
- Understand explanations for all pictograms used on the mower or in the instructions.

## Gasoline

### ▲ WARNING

**Gasoline is highly flammable. Take the following precautions.**

- **Store fuel in containers specifically designed for this purpose.**
- **Refuel outdoors only and do not smoke while refueling.**
- **Add fuel before starting the engine. Never remove the cap of the fuel tank or add gasoline while the engine is running or when the engine is hot.**
- **If gasoline is spilled, do not attempt to start the engine but move the machine away from the area of spillage and avoid creating any source of ignition until gasoline vapors have dissipated.**
- **Replace all fuel tank and container caps securely.**

## Preparation

- While mowing, always wear substantial footwear and long trousers. Do not operate the equipment when barefoot or wearing open sandals.
- Thoroughly inspect the area where the equipment is to be used and remove all stones, sticks, wires, bones and other foreign objects.
- Before using, always visually inspect to see that guards, and safety devices, such as deflectors and/or grass catchers, are in place and working correctly.
- Before using, always visually inspect to see that the blades, blade bolts and cutter assembly are not worn or damaged. Replace worn or damaged blades and bolts in sets to preserve balance.

## Starting

Start the engine carefully according to instructions and with feet well away from the blade(s) and not in front of the discharge chute.

## Operation

- Never mow while people, especially children, or pets are nearby.
- Mow only in daylight or in good artificial light.
- Stay alert for holes in the terrain, and other hidden hazards.

- Do not put hands or feet near or under rotating parts. Keep clear of the discharge opening at all times.
- Never pick up or carry a lawn mower while the engine is running.
- Use extreme caution when reversing or pulling a pedestrian controlled lawn mower towards you.
- Walk, never run.
- Slopes:
  - Do not mow excessively steep slopes.
  - Exercise extreme caution when on slopes.
  - Mow across the face of slopes, never up and down, and exercise extreme caution when changing direction on slopes.
  - Always be sure of your footing on slopes.
- Reduce speed on slopes and in sharp turns to prevent overturning or loss of control.
- Stop the blade if the lawn mower has to be tilted for transportation when crossing surfaces other than grass and when transporting the lawn mower to and from the area to be mowed.
- Do not operate the engine in a confined space where dangerous carbon monoxide fumes can collect.
- Stop the engine
  - whenever you leave the lawn mower.
  - before refueling.
  - before removing the grass catcher.
  - before making height adjustment unless adjustment can be made from the operator's position.
- Stop the engine and disconnect the spark-plug wire.
  - before clearing blockages or unclogging chute.
  - before checking, cleaning or working on the lawn mower.
  - after striking a foreign object, inspect the lawn mower for damage and make repairs before restarting and operating the lawn mower.
  - if lawn mower starts to vibrate abnormally (check immediately).
- Lightning can cause severe injury or death. If you see lightning or hear thunder in the area, do not operate the machine; seek shelter.
- Watch out for traffic when crossing or near roadways.
- Never store the equipment with gasoline in the tank and inside a building where fumes can reach an open flame or spark.
- Allow the engine to cool before storing in any enclosure.
- To reduce the fire hazard, keep the engine, silencer, battery compartment, and gasoline storage area free of grass, leaves, or excessive grease.
- Check the grass catcher components and the discharge guard frequently and replace with manufacturer's recommended parts, when necessary.
- Replace worn or damaged parts for safety.
- Replace faulty silencers.
- If the fuel tank has to be drained, do this outdoors.
- Do not change the engine governor settings or overspeed the engine. Operating an engine at excessive speed can increase the hazard of personal injury.
- Be careful during adjustment of the lawn mower to prevent entrapment of the fingers between moving blades and fixed parts of the lawn mower.
- **To ensure the best performance and safety, purchase only genuine Toro replacement parts and accessories. Do not use *will fit* parts and accessories; they may cause a safety hazard.**

## Sound Pressure

This unit has a sound pressure level at the operator's ear of 90 dBA, which includes an Uncertainty Value (K) of 1 dBA.

The sound pressure level was determined according to the procedures outlined in EN 836.

## Sound Power

This unit has a guaranteed sound power level of 98 dBA, which includes an Uncertainty Value (K) of 1 dBA.

The sound power level was determined according to the procedures outlined in ISO 11094.

## Hand/Arm Vibration

Measured vibration level for right hand = 5.0 m/s<sup>2</sup>

Measured vibration level for left hand = 5.2 m/s<sup>2</sup>

Uncertainty Value (K) = 2.1 m/s<sup>2</sup>

Measured values were determined according to the procedures outlined in EN 836.

## Maintenance and Storage

- Keep all nuts, bolts, and screws tight to be sure the equipment is in safe working condition.
- Do not use pressure-cleaning equipment on machine.

# Safety and Instructional Decals

**Important:** Safety and instruction decals are located near areas of potential danger. Replace damaged decals.

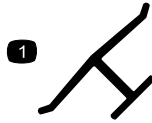

**Manufacturer's Mark**

1. Indicates the blade is identified as a part from the original machine manufacturer.

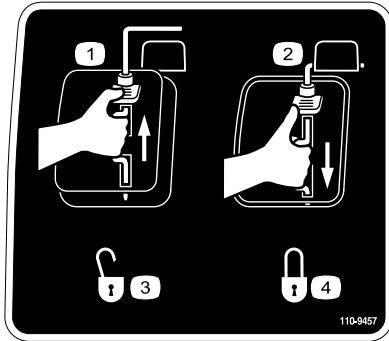

**110-9457**

- |                      |             |
|----------------------|-------------|
| 1. Engine switch Off | 3. Unlocked |
| 2. Engine switch On  | 4. Locked   |

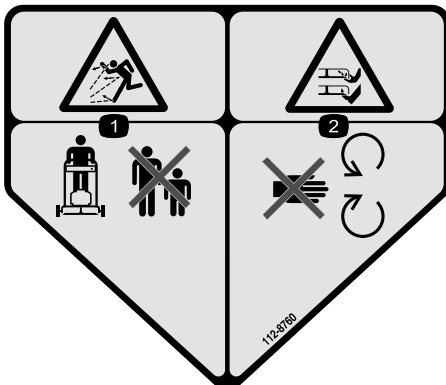

**112-8760**

1. Thrown object hazard—keep bystanders a safe distance from the machine.
2. Cutting/dismemberment of hand or foot—stay away from moving parts.



**114-7982**

1. Warning—read the *Operator's Manual*.
2. Thrown object hazard—keep bystanders a safe distance from the machine.
3. Cutting/dismemberment hazard of hand or foot, mower blade—disconnect the spark plug wire and read the instructions before servicing or performing maintenance.
4. Cutting/dismemberment hazard of hand or foot, mower blade—stay away from moving parts.
5. Cutting/dismemberment hazard of hand or foot, mower blade—do not operate up and down slopes; operate side to side on slopes; stop the engine before leaving the operating position; and look behind you when backing up.



**119-3796**

1. To engage the blade, press the button.
2. Pull back the bail to the handle.

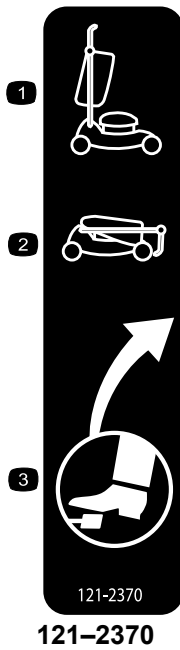

121-2370

- 
- 1. Handle in raised position
  - 2. Handle in lowered position
  - 3. Foot pedal location

# Setup

**Important:** Remove and discard the protective plastic sheet that covers the engine.

## 1

### Unfolding the Handle

**No Parts Required**

#### Procedure

1. Move the handle rearward and hold the upper handle in place (Figure 3).

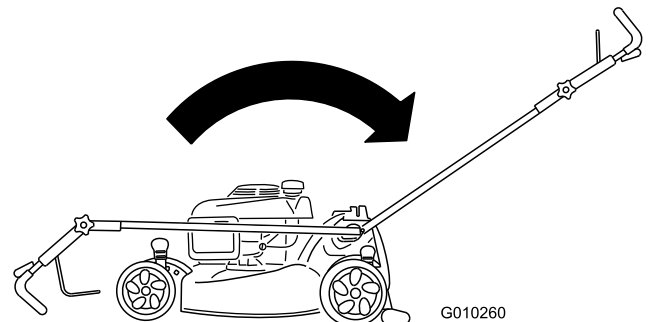
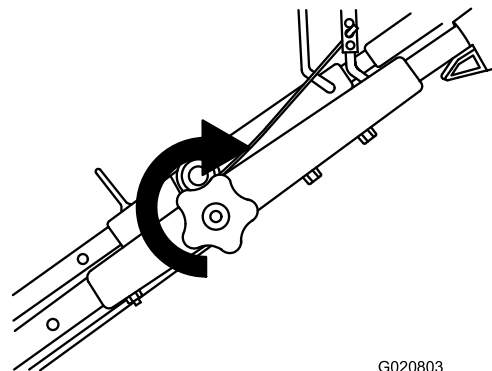

**Figure 3**

---

**Note:** The handle will click into position.

2. Tighten the upper handle knob as tight as you can (Figure 4).



**Figure 4**

# 2

## Installing the Recoil-starter Rope in the Rope Guide

### No Parts Required

### Procedure

**Important:** To start the engine safely and easily whenever you use the machine, install the recoil-starter rope in the rope guide.

Pull the recoil-starter rope through the rope guide on the handle (Figure 5).

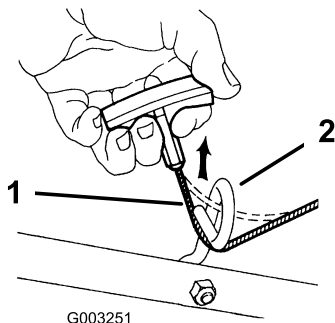

Figure 5

1. Recoil-starter rope
2. Rope guide

# 3

## Filling the Engine with Oil

### No Parts Required

### Procedure

**Important:** Your machine does not come with oil in the engine. Before starting the engine, fill the engine crankcase with oil.

1. Move the machine to a level surface.
2. Remove the dipstick (Figure 6) and pour about 3/4 of the crankcase capacity of oil into the oil-fill tube.

**Note:** Max fill: 0.55 l (0.58 qt), type: SAE 30 detergent oil with an API service classification of SF, SG, SH, SJ, SL, or higher.

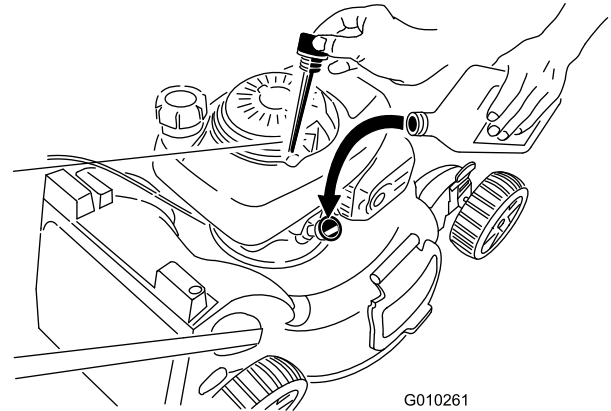
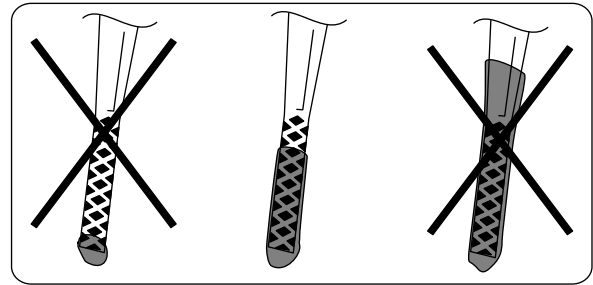

Figure 6

3. Wipe the dipstick clean with a clean cloth.
4. Insert the dipstick into the oil-fill tube, **but do not screw it in.**
5. Remove the dipstick and read the oil level on the dipstick; refer to Figure 6.
  - If the oil level is too low, slowly pour a small amount of oil into the oil-fill tube, wait 3 minutes, and then repeat steps 3 through 5 until the oil level is correct as shown in Figure 14.
  - If the oil level is too high, drain the excess oil until the oil level is correct as shown in Figure 14. To drain the excess oil, refer to Changing the Engine Oil (page 16).
6. Install the dipstick into the oil-fill tube securely.

**Important:** If the oil level in the crankcase is too low or too high and you run the engine, you may damage the engine.

**Important:** *Change the engine oil after the first 5 operating hours; change it yearly thereafter. Refer to Changing the Engine Oil (page 16).*

# 4

## Installing the Mulch Plug or the Grass Bag

### No Parts Required

### Procedure

You must correctly install either the mulch plug (for recycling or side-discharging the grass clippings) or the grass bag; otherwise, **the engine will not start**.

The machine has a safety switch (located at the bottom of the channel on the upper right rear of the machine) that prevents the machine from operating without a mulch plug or a grass bag in place. This prevents the machine from throwing debris at the operator through the rear opening.

For the switch to detect the mulch plug, the top of the mulch plug lever must **lie fully** in the **bottom of the channel** (Figure 7).

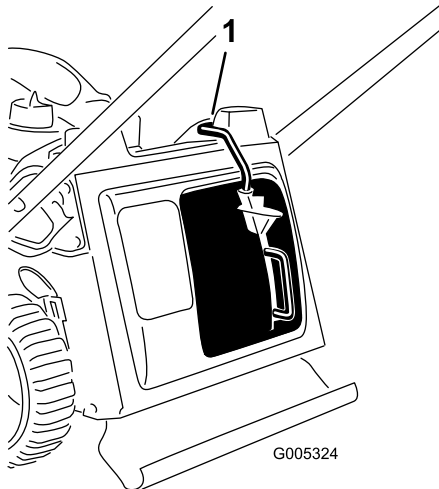

**Figure 7**

1. The top of mulch plug lever in the switch channel

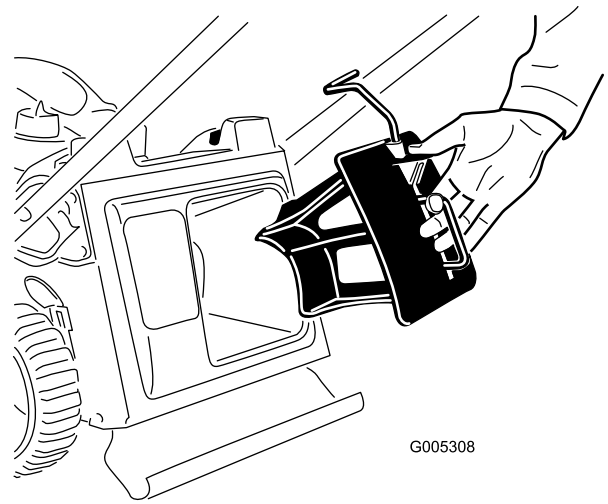

**Figure 8**

2. Squeeze the button on the lever with your thumb, and fully insert the mulch plug into the opening (Figure 9).

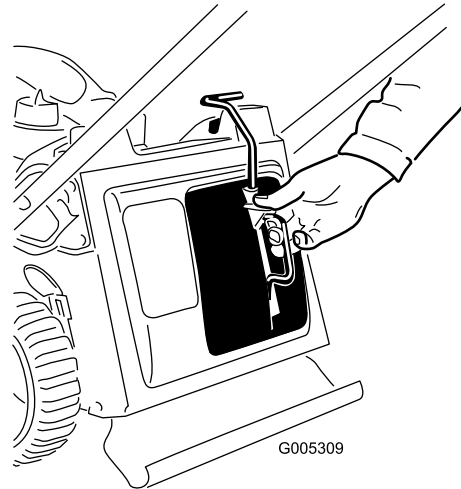
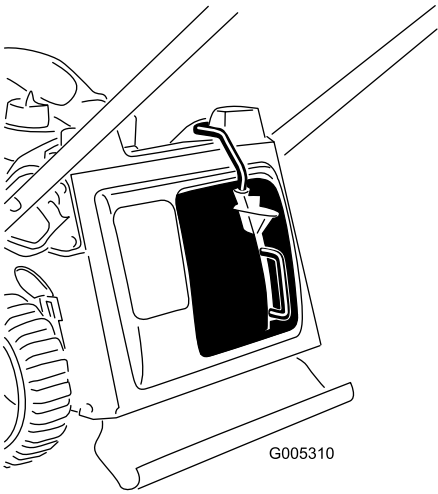

**Figure 9**

3. Release the button on the lever and ensure that the top of the lever is lies fully in the switch channel (Figure 10). **If the top of the lever is not in the switch channel, your machine will not start!**

1. Insert the mulch plug into the machine if it is not already installed (Figure 8).

# Product Overview



**Figure 10**

**Note:** If the lever does not latch properly, disconnect the wire from the spark plug and check for and remove any debris buildup in the tunnel.

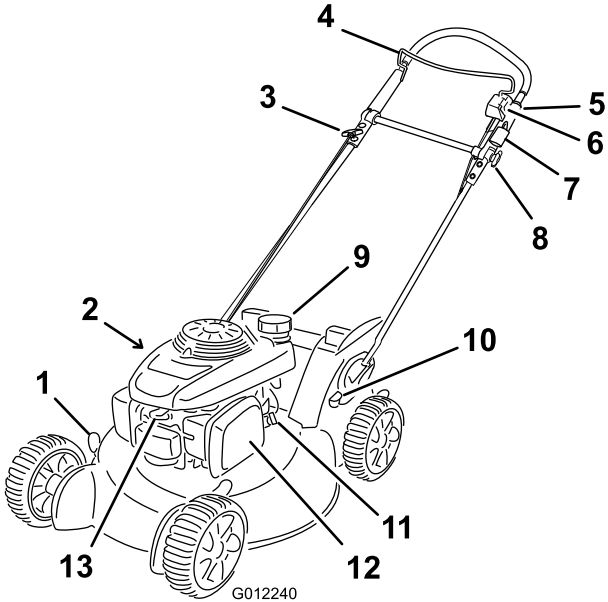

**Figure 11**

- 1. Cutting-height lever (4)
- 2. Oil fill/dipstick (not shown)
- 3. Recoil-start handle
- 4. Blade-control bar
- 5. Upper handle
- 6. Blade-control button
- 7. Ignition switch
- 8. Upper handle knob (2)
- 9. Fuel-tank cap
- 10. Foot pedal
- 11. Fuel valve
- 12. Air filter
- 13. Spark plug

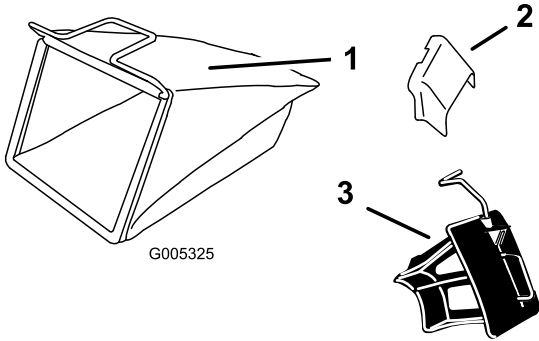

**Figure 12**

- 1. Grass bag
- 2. Side-discharge chute
- 3. Mulch plug (comes installed on the machine)

## Specifications

Model	Weight	Length	Width	Height
20897	34 kg (75 lb)	159 cm (63 inches)	56 cm (22 inches)	110 cm (43 inches)



# Operation

## Filling the Fuel Tank

### Recommended Fuel:

- For best results, use only clean, fresh (less than 30 days old), unleaded gasoline with an octane rating of 87 or higher ((R+M)/2 rating method).
- **Ethanol:** Gasoline with up to 10% ethanol (gasohol) or 15% MTBE (methyl tertiary butyl ether) by volume is acceptable. Ethanol and MTBE are not the same. Gasoline with 15% ethanol (E15) by volume is not approved for use. **Never use gasoline that contains more than 10% ethanol by volume**, such as E15 (contains 15% ethanol), E20 (contains 20% ethanol), or E85 (contains up to 85% ethanol). Using unapproved gasoline may cause performance problems and/or engine damage which may not be covered under warranty.
- **Do not** use gasoline containing methanol.
- **Do not** store fuel either in the fuel tank or fuel containers over the winter unless a fuel stabilizer is used.
- **Do not** add oil to gasoline.

**Important:** To reduce starting problems, add fuel stabilizer to the fuel all season, mixing it with gasoline less than 30 days old; run the machine dry before storing it for more than 30 days.

Do not use fuel additives other than a fuel stabilizer/conditioner. Do not use fuel stabilizers with an alcohol base such as ethanol, methanol, or isopropanol.

### **⚠ DANGER**

Gasoline is extremely flammable and explosive. A fire or explosion from gasoline can burn you and others.

- To prevent a static charge from igniting the gasoline, place the container and/or machine directly on the ground before filling, not in a vehicle or on an object.
- Fill the tank outdoors when the engine is cold. Wipe up spills.
- Do not handle gasoline when smoking or around an open flame or sparks.
- Store gasoline in an approved fuel container, out of the reach of children.

1. Clean around the fuel-tank cap, and remove the cap from the tank (Figure 13).

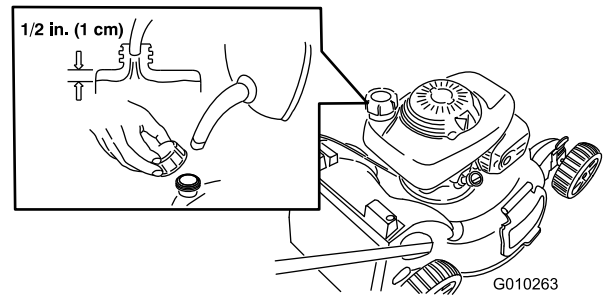

Figure 13

2. Fill the fuel tank, leaving at least 1 cm (1/2 inch) from the bottom of the neck empty to allow the gasoline room to expand.
3. Install the fuel tank cap and tighten it securely by hand.

## Checking the Engine Oil Level

**Service Interval:** Before each use or daily

**Note:** Max fill: 0.55 l (0.58 qt), type: SAE 30 detergent oil with an API service classification of SF, SG, SH, SJ, SL, or higher.

1. Move the machine to a level surface.
2. Remove the dipstick (Figure 14).

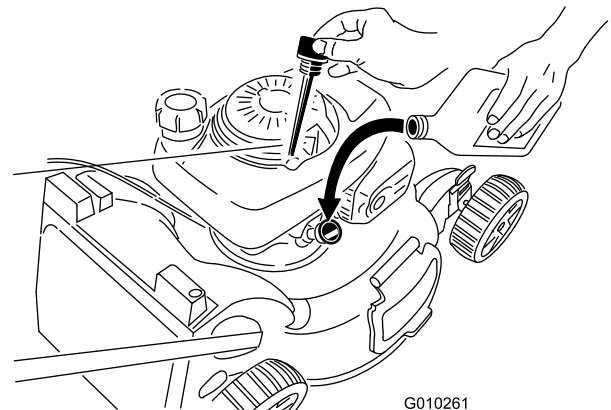
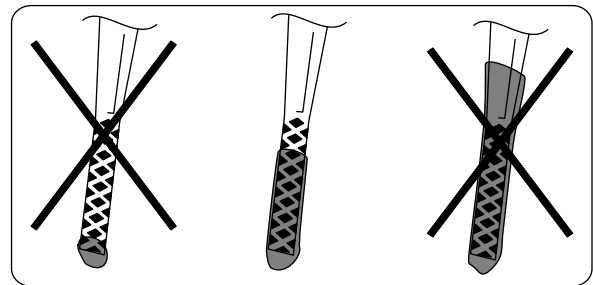

Figure 14

3. Wipe the dipstick clean with a clean cloth.
4. Insert the dipstick into the oil-fill tube, **but do not screw it in**.
5. Remove the dipstick and read the oil level on the dipstick; refer to Figure 14.

- If the oil level is too low, slowly pour a small amount of oil into the oil-fill tube, wait 3 minutes, and then repeat steps 3 through 5 until the oil level is correct as shown in Figure 6.
- If the oil level is too high, drain the excess oil until the oil level is correct as shown in Figure 6. To drain the excess oil, refer to Changing the Engine Oil (page 16).

**Important:** If the oil level in the crankcase is too low or too high and you run the engine, you may damage the engine.

6. Install the dipstick into the oil-fill tube securely.

## Adjusting the Cutting Height

### ⚠ WARNING

Adjusting the cutting height may bring you into contact with the moving blade, causing serious injury.

- Stop the engine and wait for all moving parts to stop.
- Do not put your fingers under the housing when adjusting the cutting height.

Adjust the cutting height as desired. Set the front wheels to the same height as the rear wheels (Figure 15).

**Note:** To raise the machine, move all the cutting-height levers forward; to lower the machine, move all the cutting-height levers rearward.

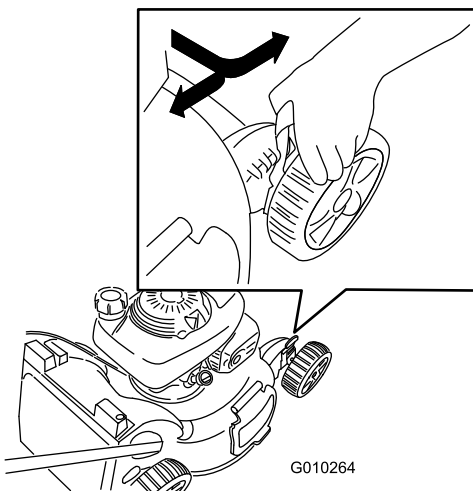

Figure 15

**Note:** The cutting-height settings are 25 mm (1 inch); 35 mm (1-3/8 inch); 44 mm (1-3/4 inch); 54 mm (2-1/8 inches); 64 mm (2-1/2 inches); 73 mm (2-7/8 inches); 83 mm (3-1/4 inches); 92 mm (3-5/8 inches); and 102 mm (4 inches).

## Starting the Engine

**Important:** The machine has a safety switch that prevents you from starting the machine unless you first install the mulch plug or the grass bag securely on the machine.

1. Install the mulch plug (Figure 16) or the grass bag (Figure 17) on the machine.

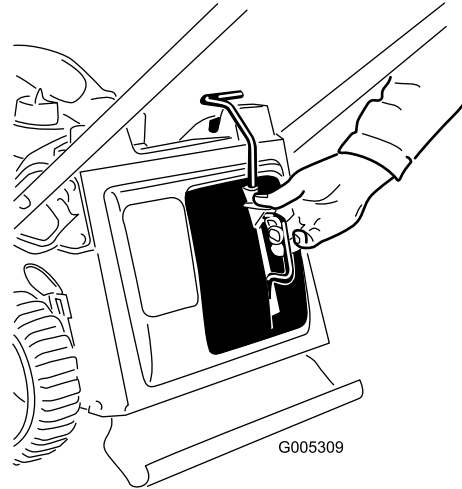

Figure 16

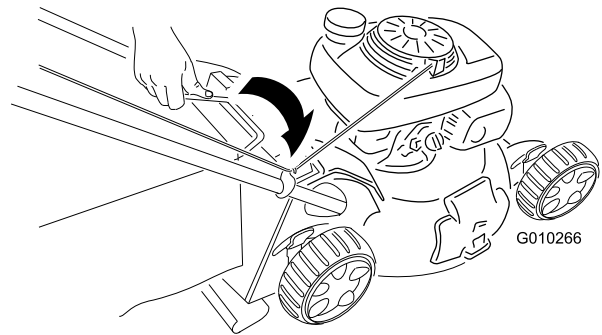

Figure 17

2. Turn the fuel valve lever to the On position (Figure 20).

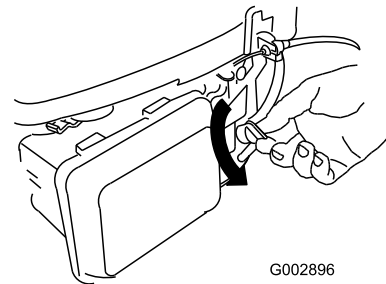

Figure 18

3. Pull the recoil starter (Figure 19).

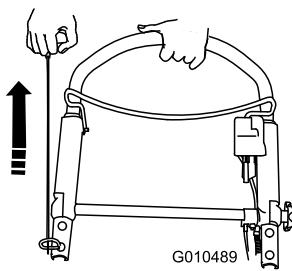

Figure 19

**Note:** If the machine still does not start, contact an Authorized Service Dealer.

## Using the Self-propel Drive

To operate the self-propel drive, simply walk with your hands on the upper handle and your elbows at your sides, and the machine will automatically keep pace with you.

## Engaging the Blade

When you start the engine the blade does not turn. You must engage the blade to mow.

1. Push the blade-control button and pull the blade-control bar to the handle (Figure 20).

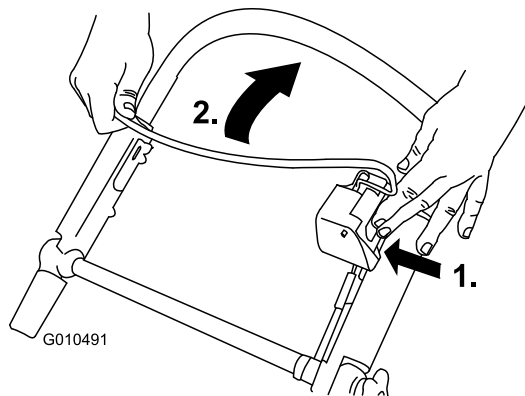

Figure 20

2. Hold the blade-control bar against the handle (Figure 21).

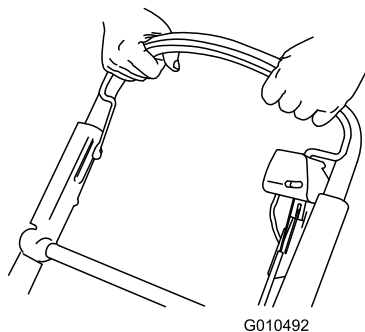

Figure 21

## Disengaging the Blade

Release the blade-control bar (Figure 22).

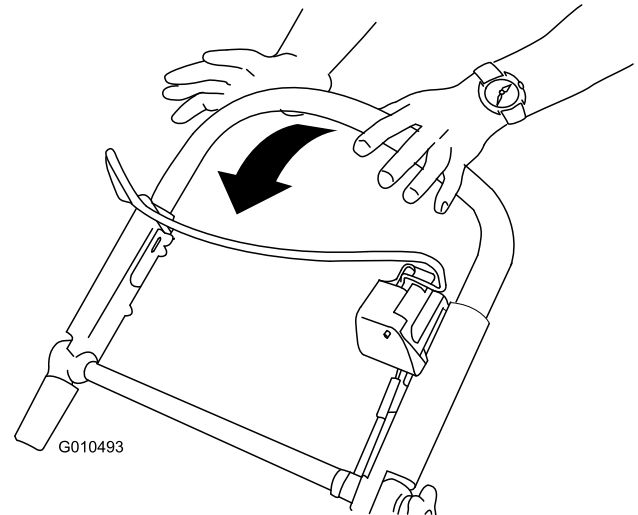

Figure 22

**Important:** When you release the blade-control bar, the blade should stop within 3 seconds. If it does not stop properly, stop using your machine immediately and contact an Authorized Service Dealer.

## Checking the Blade-stop System Operation

Check the blade-control bar before each use to ensure that the blade-stop system is operating properly.

## Using the Grass Bag

**Service Interval:** Before each use or daily

You can use the grass bag to perform an additional test to check the blade stop system.

1. Install the empty grass bag on the machine.
2. Start the engine.
3. Engage the blade.

**Note:** The bag should begin to inflate, indicating that the blade is engaged and rotating.

4. Release the blade-control bar.

**Note:** If the bag does not immediately deflate, the blade is still rotating. The blade stop system may be deteriorating and, if ignored, could result in an unsafe operating condition. Have the machine inspected and serviced by an Authorized Service Dealer.

5. Stop the engine and wait for all moving parts to stop.

## Not Using the Grass Bag

1. Move the machine onto a paved surface in a non-windy area.
2. Set all 4 wheels to the 89 mm (3-1/2 inch) height-of-cut setting.
3. Take a half sheet of newspaper and crumple it into a ball small enough to go under the machine housing (about 76 mm or 3 inches in diameter).
4. Place the newspaper ball about 13 cm (5 inches) in front of the machine.
5. Start the engine.
6. Engage the blade.
7. Immediately push the mower over the newspaper ball.
8. Release the blade-control bar.
9. Stop the engine and wait for all moving parts to stop.
10. Go to the front of the machine and check the newspaper ball.
  - If the newspaper ball did not go under the machine, repeat steps 4 through 10.
  - If the newspaper is unravelled or shredded, the blade did not stop properly, which could result in an unsafe operating condition. Contact an Authorized Service Dealer.

## Stopping the Engine

Hold down the ignition switch in the Stop position until the engine stops.

**Important:** When you release the blade-control bar, both the engine and blade should stop within 3 seconds. If they do not stop properly, stop using your machine immediately and contact an Authorized Service Dealer.

## Mulching the Clippings

Your machine comes from the factory ready to mulch the grass and leaf clippings back into the lawn.

If the grass bag is on the machine, remove it; refer to Removing the Grass Bag (page 13) before mulching the clippings. If the side-discharge chute is on the machine, remove it and lock the side-discharge door; refer to Removing the Side-discharge Chute (page 14) before mulching the clippings.

**Important:** The machine has a safety switch that prevents you from starting the machine unless you first install the mulch plug securely on the machine (Figure 23).

Install the mulch plug as illustrated in Figure 23.

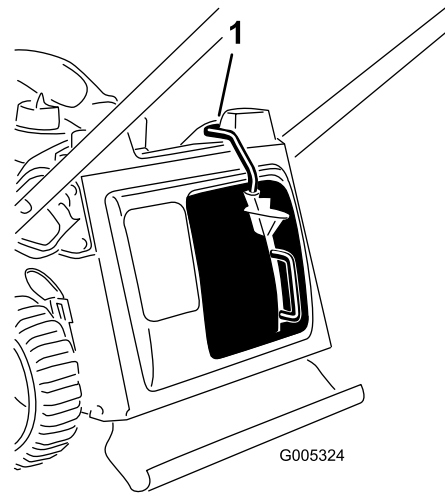

**Figure 23**

1. Top of mulch plug lever in switch channel

## Bagging the Clippings

Use the grass bag when you want to collect grass and leaf clippings from the lawn.

### **▲ WARNING**

A worn grass bag could allow small stones and other similar debris to be thrown toward the operator or a bystander, and result in serious personal injury or death.

**Check the grass bag frequently. If it is damaged, install a new Toro replacement bag.**

If the side-discharge chute is on the machine, remove it and lock the side-discharge door; refer to Removing the Side-discharge Chute (page 14) before bagging the clippings.

### **▲ WARNING**

The blade is sharp; contacting the blade can result in serious personal injury.

**Stop the engine and wait for all moving parts to stop before leaving the operating position.**

## Installing the Grass Bag

1. Remove the mulch plug (Figure 24).

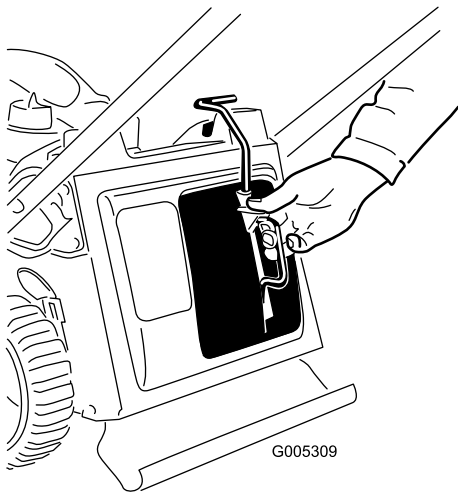

**Figure 24**

## Removing the Grass Bag

1. Route the starter rope around the lower-rope guide (Figure 27).

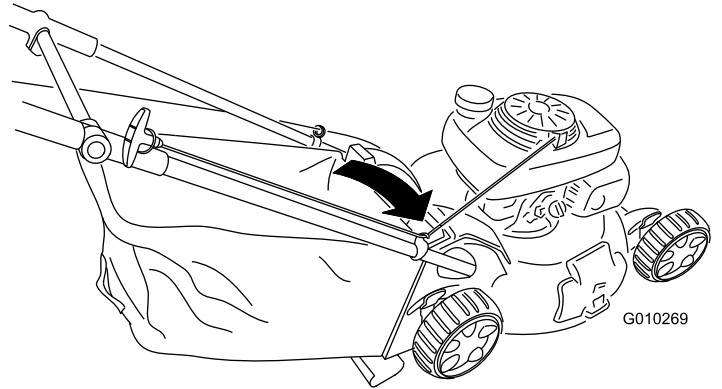

**Figure 27**

2. Route the starter rope around the lower-rope guide (Figure 25).

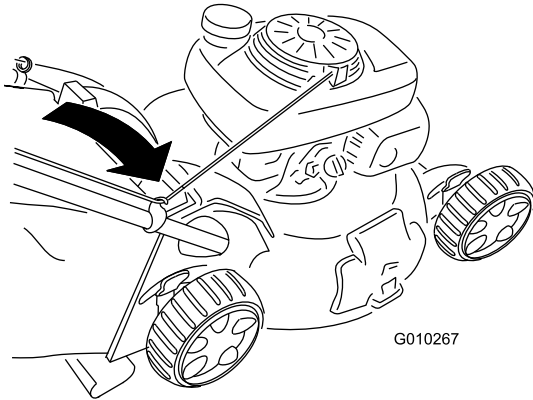

**Figure 25**

2. Lift the grass-bag handle out from the grooves at the top of the machine, and remove the bag from the machine (Figure 28).

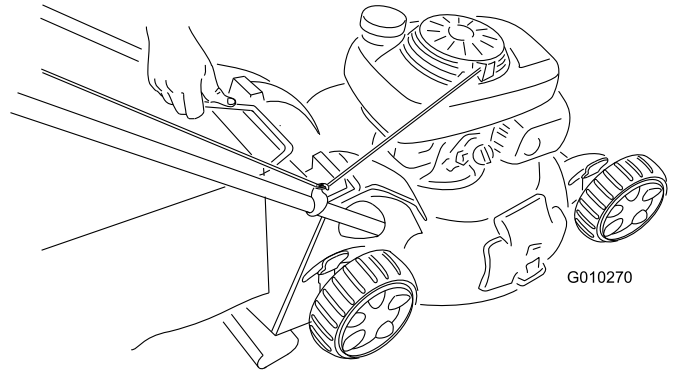
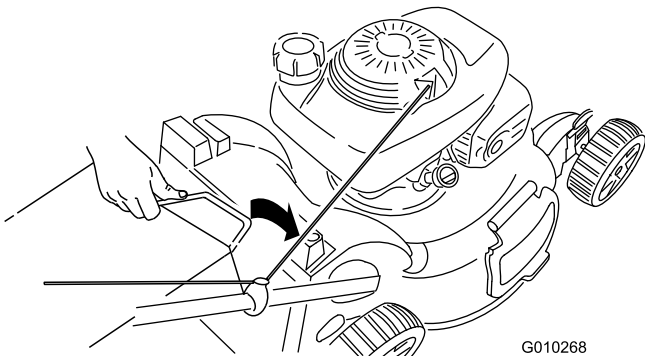

**Figure 28**

**Note:** The lower rope guide releases the starter rope when you pull the recoil-start handle.

3. Insert the grass-bag handle into the grooves at the top of the machine (Figure 26).

**Important:** The machine has a safety switch that prevents you from starting the machine unless you first install the grass bag securely on the machine.



**Figure 26**

3. Insert the mulch plug (Figure 29).

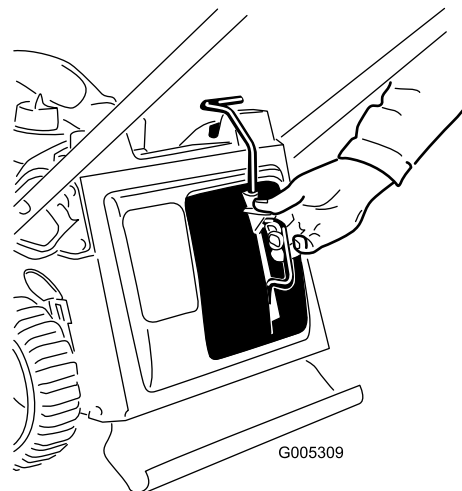

**Figure 29**

## Side-discharging the Clippings

Use the side discharge for cutting very tall grass.

If the grass bag is on the machine, remove it before side-discharging the clippings; refer to Removing the Grass Bag (page 13).

**Important:** The machine has a safety switch that prevents you from starting the machine unless you first install the mulch plug securely on the machine; refer to Mulching the Clippings (page 12).

## Installing the Side-discharge Chute

1. Unlock the side-discharge door (Figure 30).

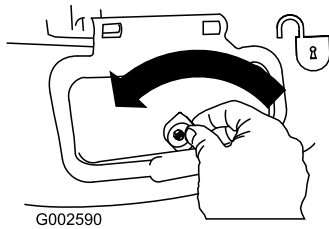

Figure 30

2. Lift open the side-discharge door (Figure 31).

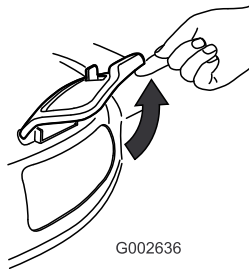

Figure 31

3. Install the side discharge chute and close the door onto the chute (Figure 32).

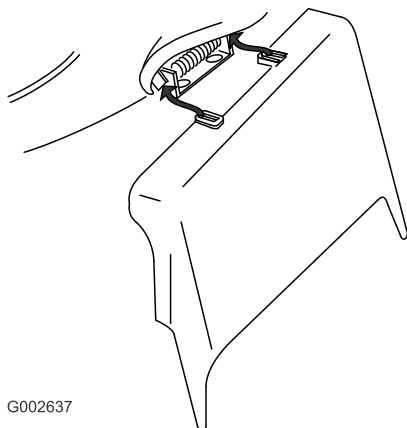

Figure 32

## Removing the Side-discharge Chute

To remove the side-discharge chute, reverse the steps above.

**Important:** Lock the side-discharge door after you close it (Figure 33).

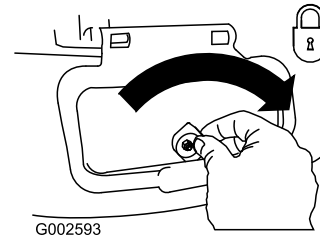

Figure 33

## Operating Tips

### General Mowing Tips

- Clear the area of sticks, stones, wire, branches, and other debris that the blade could hit.
- Avoid striking solid objects with the blade. Never deliberately mow over any object.
- If the machine strikes an object or starts to vibrate, immediately stop the engine, disconnect the wire from the spark plug, and examine the machine for damage.
- For best performance, install a new blade before the cutting season begins.
- Replace the blade when necessary with a Toro replacement blade.

### Cutting Grass

- Cut only about a third of the grass blade at a time. Do not cut below the 51 mm (2 in) setting unless the grass is sparse or it is late fall when grass growth begins to slow down. Refer to Adjusting the Cutting Height (page 10).
- When cutting grass over 15 cm (6 inches) tall, mow at the highest cutting height setting and walk slower; then mow again at a lower setting for the best lawn appearance. If the grass is too long, the machine may plug and cause the engine to stall.
- Mow only dry grass or leaves. Wet grass and leaves tend to clump on the yard and can cause the machine to plug or the engine to stall.

### **⚠ WARNING**

**Wet grass or leaves can cause serious injury if you slip and contact the blade. Mow only in dry conditions.**

- Be aware of a potential fire hazard in very dry conditions, follow all local fire warnings, and keep the machine free of dry grass and leaf debris.

- Alternate the mowing direction. This helps disperse the clippings over the lawn for even fertilization.
- If the finished lawn appearance is unsatisfactory, try one or more of the following:
  - Replace the blade or have it sharpened.
  - Walk at a slower pace while mowing.
  - Raise the cutting height on your machine.
  - Cut the grass more frequently.
  - Overlap cutting swaths instead of cutting a full swath with each pass.
  - Set the cutting height on the front wheels one notch lower than the rear wheels. For example, set the front

wheels at 51 mm (2 in) and the rear wheels at 64 mm (2-1/2 in).

## Cutting Leaves

- After cutting the lawn, ensure that half of the lawn shows through the cut leaf cover. You may need to make more than one pass over the leaves.
- If there are more than 13 cm (5 inches) of leaves on the lawn, set the front cutting height one or two notches higher than the rear cutting height.
- Slow down your mowing speed if the machine does not cut the leaves finely enough.

# Maintenance

**Note:** Determine the left and right sides of the machine from the normal operating position.

## Recommended Maintenance Schedule(s)

Maintenance Service Interval	Maintenance Procedure
After the first 5 hours	<ul style="list-style-type: none"> <li>• Change the engine oil.</li> </ul>
Before each use or daily	<ul style="list-style-type: none"> <li>• Check the engine oil level.</li> <li>• Check the operation of the blade-stop system.</li> <li>• Ensure that the blade stops within 3 seconds after releasing the blade-control bar.</li> <li>• Check the air cleaner for dirt and damage and clean or replace it if necessary.</li> </ul>
After each use	<ul style="list-style-type: none"> <li>• Clean grass clippings and dirt from under the machine housing.</li> </ul>
Every 25 hours	<ul style="list-style-type: none"> <li>• Clean the blade-stop system shield.</li> </ul>
Before storage	<ul style="list-style-type: none"> <li>• Empty the fuel tank before repairs as directed and before annual storage.</li> </ul>
Yearly	<ul style="list-style-type: none"> <li>• Clean or replace the air filter (more frequently in dusty operating conditions).</li> <li>• Change the engine oil.</li> <li>• Lubricate the upper handle.</li> <li>• Replace the blade or have it sharpened (more frequently if the edge dulls quickly).</li> <li>• Refer to your engine operator's manual for any additional yearly maintenance procedures.</li> </ul>

**Important:** Refer to your engine operator's manual for additional maintenance procedures.

## Preparing for Maintenance

1. Stop the engine and wait for all moving parts to stop.
2. Disconnect the spark-plug wire from the spark plug (Figure 34) before performing any maintenance procedure.

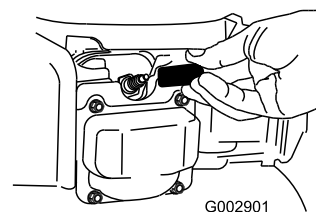

**Figure 34**

3. After performing the maintenance procedure(s), connect the spark-plug wire to the spark plug.

**Important:** Before tipping the machine to change the oil or replace the blade, allow the fuel tank to run dry through normal use. If you must tip

the machine prior to running out of fuel, use a hand fuel pump to remove the fuel. Always tip the machine onto its side with the dipstick down.

## ⚠ WARNING

Tipping the machine may cause the fuel to leak. Gasoline is flammable and explosive, and can cause personal injury.

Run the engine dry or remove the gasoline with a hand pump; never siphon.

## Servicing the Air Filter

**Service Interval:** Before each use or daily

Yearly

1. Press down on the latch tabs on top of the air-cleaner cover (Figure 35).

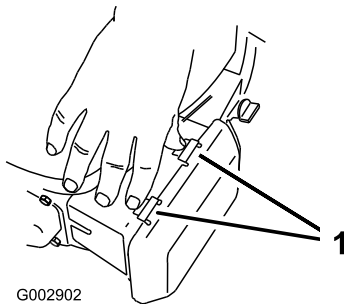

Figure 35

1. Latch tabs

2. Open the cover.
3. Remove the air filter (Figure 36).

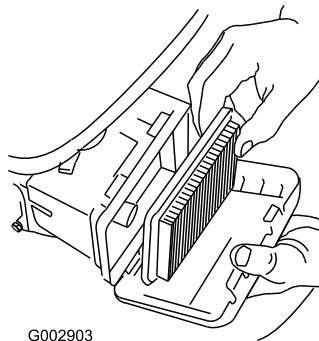

Figure 36

4. If the air filter is damaged or is wet with oil or fuel, replace it.
5. If the air filter is dirty, tap it on a hard surface several times or blow compressed air less than 30 psi (207 kPa) through the side of the filter that faces the engine.

**Note:** Do not brush the dirt off the filter; brushing forces dirt into the fibers.

6. Remove dirt from the air cleaner body and cover using a moist rag. **Do not wipe dirt into the air duct.**
7. Install the filter into the air cleaner.
8. Close the cover.

## Changing the Engine Oil

**Service Interval:** After the first 5 hours

Yearly

1. Move the machine to a level surface.
2. Ensure that the fuel tank contains little or no fuel so that fuel does not leak out when you tip the machine onto its side.
3. Run the engine a few minutes before changing the oil to warm it.

**Note:** Warm oil flows better and carries more contaminants.

4. Disconnect the wire from the spark plug; refer to Preparing for Maintenance (page 15).
5. Place an oil drain pan beside the machine on the side nearest to the oil-fill tube.
6. Remove the dipstick from the oil-fill tube (Figure 37).

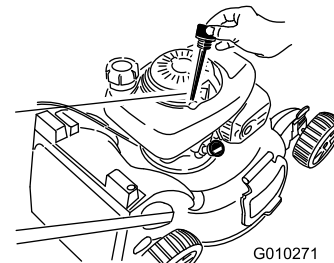

Figure 37

7. Tip the machine onto its side, with the oil-fill tube down, to drain the used oil through the oil-fill tube into the oil-drain pan (Figure 38).

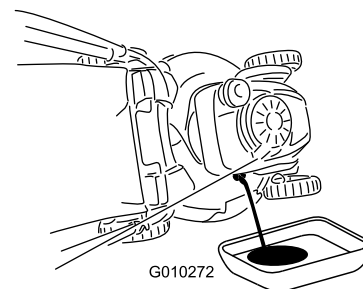

Figure 38

8. After draining the used oil, return the machine to the operating position.



- Pour about 3/4 of the crankcase capacity of oil in the crankcase.

**Note:** Max fill: 0.55 l (0.58 qt), type: SAE 30 detergent oil with an API service classification of SF, SG, SH, SJ, SL, or higher.

- Wipe the dipstick clean with a clean cloth.
- Insert the dipstick into the oil-fill tube, **but do not screw it in**.
- Remove the dipstick and read the oil level on the dipstick (Figure 39).

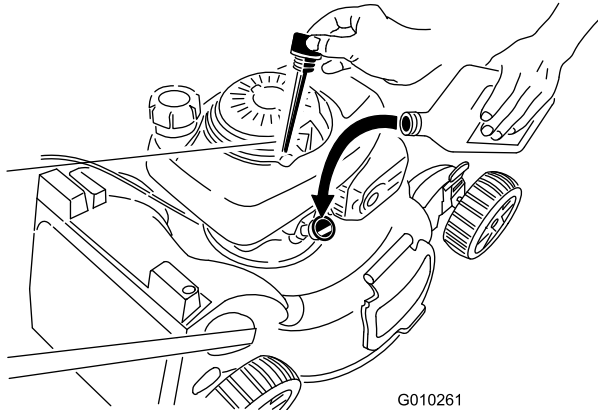
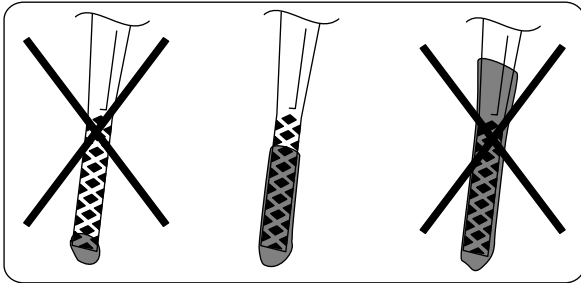

**Figure 39**

- If the oil level is too low, slowly pour a small amount of oil into the oil-fill tube, wait 3 minutes, and then repeat steps 10 through 12 until the oil level is at the **Full** mark on the dipstick.
- If the oil level is too high, drain the excess oil until the oil level is correct as shown in Figure 39.

**Important:** If the oil level in the crankcase is too low or too high and you run the engine, you may damage the engine.

- Install the dipstick into the oil-fill tube securely.
- Dispose of the used oil properly at a local recycling center.

## Lubricating the Upper Handle

**Service Interval:** Yearly

Lubricate the left and right sides of the upper handle with a low-viscosity silicone spray lubricant.

- Spray the outer plastic end of the inner handle (Figure 40).

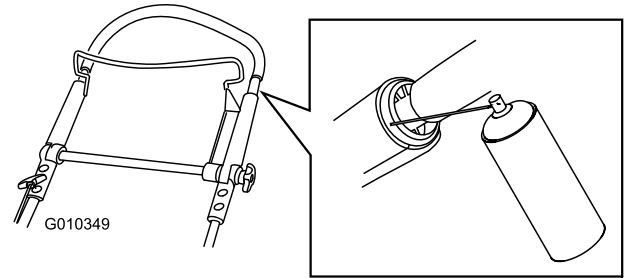

**Figure 40**

**Note:** Use the straw that comes with the spray can to direct the spray.

- Push the upper handle fully down and spray the inner plastic surface of the outer handle (Figure 41).

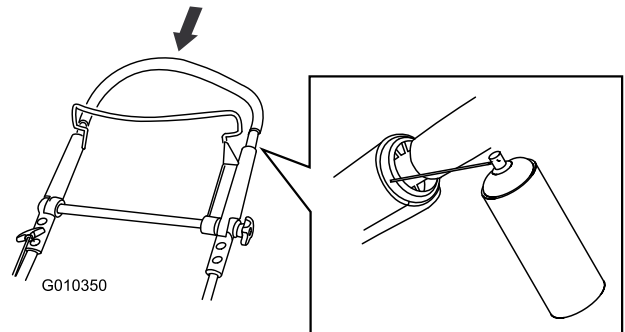

**Figure 41**

# Adjusting the Self-propel Drive

If your machine does not self-propel properly, adjust the self-propel-drive cable.

1. Loosen the nut on the cable mount (Figure 42).

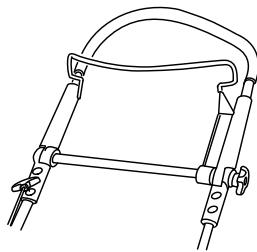
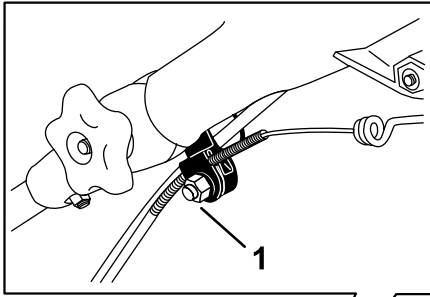
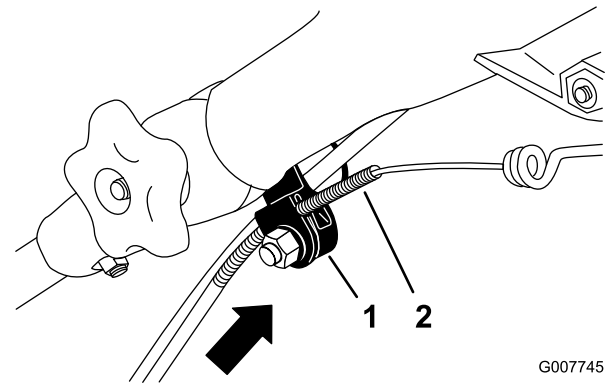

Figure 42

G010351

1. Cable mount



G007745

Figure 44

1. Cable mount
2. Cable jacket

**Important:** Moving the cable jacket upward decreases the ground speed; moving the jacket downward increases the ground speed.

5. Tighten the nut firmly.
6. Start the mower and check the adjustment.

**Note:** If the self-propel drive is not properly adjusted, repeat this procedure.

2. Pull the upper handle back fully rearward.

**Note:** If the handle does not move smoothly, refer to Lubricating the Upper Handle (page 17).

3. Pull the cable jacket downward until you remove the slack in the exposed cable (Figure 43).

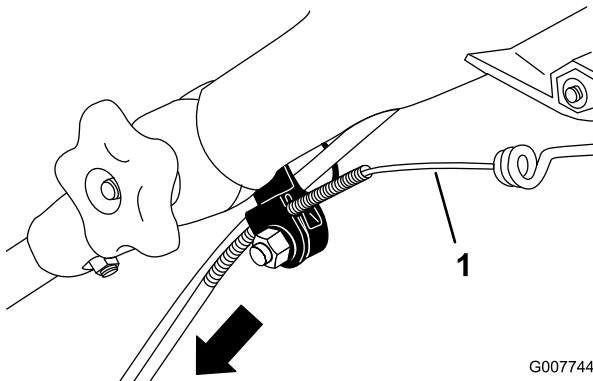

G007744

Figure 43

1. Exposed cable

4. Push the cable jacket upward 3 mm (1/8 inch).

**Note:** You can place a ruler against the upper side of the black cable mount and measure how far the upper end of the cable jacket moves (Figure 44).

# Replacing the Blade

Service Interval: Yearly

**Important:** You will need a torque wrench to install the blade properly. If you do not have a torque wrench or are uncomfortable performing this procedure, contact an Authorized Service Dealer.

Examine the blade whenever you run out of gasoline. If the blade is damaged or cracked, replace it immediately. If the blade edge is dull or nicked, have it sharpened and balanced, or replace it.

## ⚠ WARNING

The blade is sharp; contacting the blade can result in serious personal injury.

Wear gloves when servicing the blade.

1. Refer to Preparing for Maintenance (page 15).
2. Tip the machine onto its side with the dipstick down.
3. Remove the 2 blade nuts and the stiffener (Figure 45).

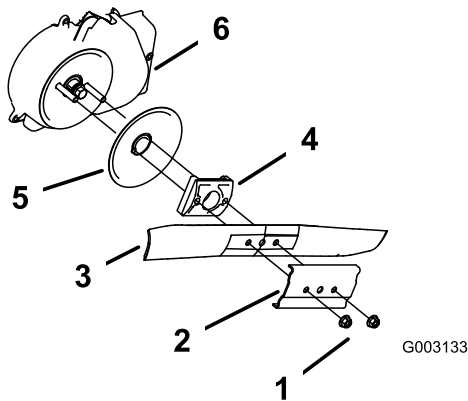

Figure 45

- |               |                             |
|---------------|-----------------------------|
| 1. Blade nuts | 4. Blade driver             |
| 2. Stiffener  | 5. Anti-scalp disk          |
| 3. Blade      | 6. Blade-stop system shield |

4. Remove the blade (Figure 45).
5. Install the new blade (Figure 45).

**Important:** Position the curved ends of the blade to point toward the mower housing.

6. Install the stiffener that you removed in step 3.
7. Install the blade nuts.

**Note:** Torque the blade nuts to 20 to 37 N-m (15 to 27 ft-lb).

# Cleaning the Blade-stop System Shield

Service Interval: Every 25 hours

1. Disconnect the spark-plug wire from the spark plug; refer to Preparing for Maintenance (page 15).
2. Tip the machine onto its side with the dipstick down.
3. Remove the 2 blade nuts and the stiffener (Figure 46).

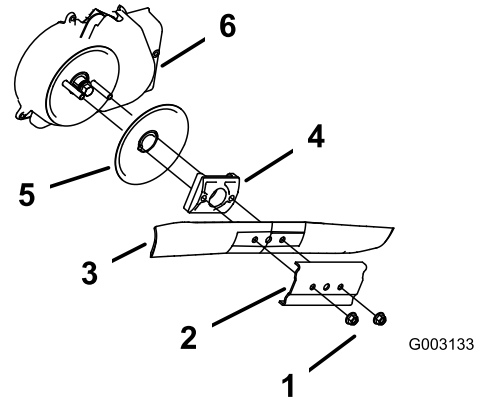

Figure 46

- |               |                             |
|---------------|-----------------------------|
| 1. Blade nuts | 4. Blade driver             |
| 2. Stiffener  | 5. Anti-scalp disk          |
| 3. Blade      | 6. Blade-stop system shield |

4. Remove the blade (Figure 46).
5. Remove the blade driver and the anti-scalp disk (Figure 46).
6. Remove the blade-stop system shield (Figure 46).
7. Brush or blow out debris from the inside of the shield and around all the parts.
8. Install the blade-stop system shield that you previously removed.
9. Install the blade driver and anti-scalp disk that you previously removed.
10. Install the blade and the stiffener with the 2 blade nuts that you previously removed (Figure 46).
11. Install the blade nuts.

**Note:** Torque the blade nuts to 20 to 37 N-m (15 to 27 ft-lb).

# Cleaning under the Machine Housing

**Service Interval:** After each use

## ⚠ WARNING

The machine may dislodge material from under the machine housing.

- Wear eye protection.
- Stay in the operating position (behind the handle) when the engine is running.
- Do not allow bystanders in the area.

For best results, clean under the machine housing soon after you have completed mowing.

1. Lower the machine to its lowest cutting-height setting; refer to Adjusting the Cutting Height (page 10).
2. Move the machine onto a flat paved surface.
3. With the engine running and the blade engaged, spray a stream of water in front of the right rear wheel (Figure 49).



**Figure 47**

**Note:** The water will splash into the path of the blade, cleaning out the clippings.

4. When no more clippings come out, stop the water and move the machine to a dry area.
5. Run the engine with the blade engaged for a few minutes to dry the housing to prevent it from rusting.

# Storage

Store the machine in a cool, clean, dry place.

## Preparing the Machine for Storage

### ⚠ WARNING

Gasoline vapors can explode.

- Do not store gasoline more than 30 days.
- Do not store the machine in an enclosure near an open flame.
- Allow the engine to cool before storing it.

1. On the last refueling of the year, add fuel stabilizer to the fuel as directed by the engine manufacturer.
2. Dispose of any unused fuel properly. Recycle it according to local codes, or use it in your automobile.

**Note:** Old fuel in the fuel tank is the leading cause of hard starting. Do not store fuel without stabilizer more than 30 days, and do not store stabilized fuel more than 90 days.

3. Run the machine until the engine stops from running out of fuel.
4. Start the engine again.
5. Allow the engine to run until it stops. When you can no longer start the engine, it is sufficiently dry.
6. Disconnect the wire from the spark plug.
7. Remove the spark plug, add 30 ml (1 oz) of oil through the spark-plug hole, and pull the starter rope slowly several times to distribute oil throughout the cylinder to prevent cylinder corrosion during the off-season.
8. Loosely install the spark plug.
9. Tighten all nuts, bolts, and screws.

## Folding the Handle

### Upright Position

1. Step on the foot pedal and hold it down (Figure 48).

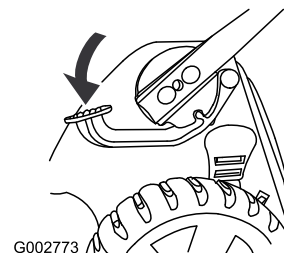
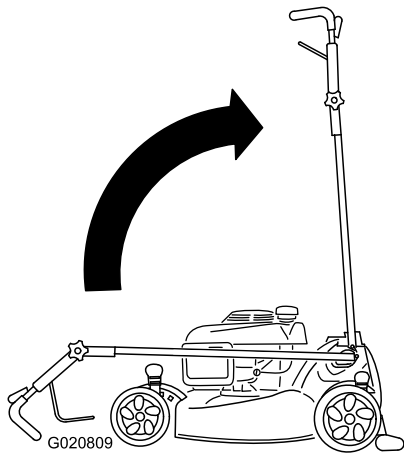

**Figure 48**

2. Move the handle to the upright position (Figure 49).

## Removing the Machine from Storage

1. Check and tighten all fasteners.
2. Remove the spark plug and spin the engine rapidly using the starter to blow excess oil from the cylinder.
3. Install the spark plug and tighten it with a torque wrench to 20 N-m (15 ft-lb).
4. Perform any needed maintenance procedures; refer to Preparing for Maintenance (page 15).
5. Check the engine oil level; refer to Checking the Engine Oil Level (page 9).
6. Fill the fuel tank with fresh gasoline; refer to Filling the Fuel Tank (page 9).
7. Connect the wire to the spark plug.

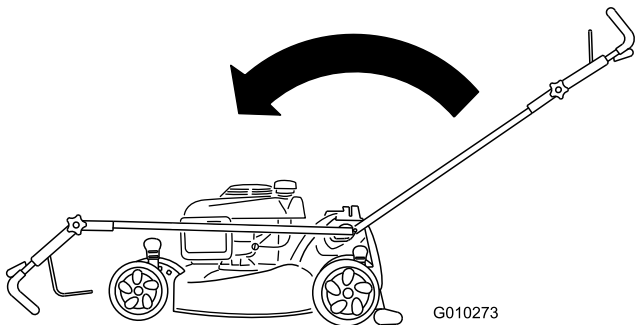

**Figure 49**

---

### Forward Position

1. With the handle in the upright position, step on the foot pedal and hold it down.
2. Move the handle all the way forward and loosen the upper handle knob (Figure 50).



**Figure 50**

3. To unfold the handle, refer to 1 Unfolding the Handle (page 5).

**Notes:**

## International Distributor List

<b>Distributor:</b>	<b>Country:</b>	<b>Phone Number:</b>	<b>Distributor:</b>	<b>Country:</b>	<b>Phone Number:</b>
Agrolanc Kft	Hungary	36 27 539 640	Maquiver S.A.	Colombia	57 1 236 4079
Balama Prima Engineering Equip.	Hong Kong	852 2155 2163	Maruyama Mfg. Co. Inc.	Japan	81 3 3252 2285
B-Ray Corporation	Korea	82 32 551 2076	Mountfield a.s.	Czech Republic	420 255 704 220
Casco Sales Company	Puerto Rico	787 788 8383	Mountfield a.s.	Slovakia	420 255 704 220
Ceres S.A.	Costa Rica	506 239 1138	Munditol S.A.	Argentina	54 11 4 821 9999
CSSC Turf Equipment (pvt) Ltd.	Sri Lanka	94 11 2746100	Norma Garden	Russia	7 495 411 61 20
Cyril Johnston & Co.	Northern Ireland	44 2890 813 121	Oslinger Turf Equipment SA	Ecuador	593 4 239 6970
Cyril Johnston & Co.	Republic of Ireland	44 2890 813 121	Oy Hako Ground and Garden Ab	Finland	358 987 00733
Equivier	Mexico	52 55 539 95444	Parkland Products Ltd.	New Zealand	64 3 34 93760
Femco S.A.	Guatemala	502 442 3277	Perfetto	Poland	48 61 8 208 416
ForGarder OU	Estonia	372 384 6060	Pratoverde SRL.	Italy	39 049 9128 128
G.Y.K. Company Ltd.	Japan	81 726 325 861	Prochaska & Cie	Austria	43 1 278 5100
Geomechaniki of Athens	Greece	30 10 935 0054	RT Cohen 2004 Ltd.	Israel	972 986 17979
Golf international Turizm	Turkey	90 216 336 5993	Riversa	Spain	34 9 52 83 7500
Guandong Golden Star	China	86 20 876 51338	Lely Turfcare	Denmark	45 66 109 200
Hako Ground and Garden	Sweden	46 35 10 0000	Solvvert S.A.S.	France	33 1 30 81 77 00
Hako Ground and Garden	Norway	47 22 90 7760	Spypros Stavrinides Limited	Cyprus	357 22 434131
Hayter Limited (U.K.)	United Kingdom	44 1279 723 444	Surge Systems India Limited	India	91 1 292299901
Hydroturf Int. Co Dubai	United Arab Emirates	97 14 347 9479	T-Markt Logistics Ltd.	Hungary	36 26 525 500
Hydroturf Egypt LLC	Egypt	202 519 4308	Toro Australia	Australia	61 3 9580 7355
Irrimac	Portugal	351 21 238 8260	Toro Europe NV	Belgium	32 14 562 960
Irrigation Products Int'l Pvt Ltd.	India	0091 44 2449 4387	Valtech	Morocco	212 5 3766 3636
Jean Heybroek b.v.	Netherlands	31 30 639 4611	Victus Emak	Poland	48 61 823 8369

### European Privacy Notice

#### The Information Toro Collects

Toro Warranty Company (Toro) respects your privacy. In order to process your warranty claim and contact you in the event of a product recall, we ask you to share certain personal information with us, either directly or through your local Toro company or dealer.

The Toro warranty system is hosted on servers located within the United States where privacy law may not provide the same protection as applies in your country.

BY SHARING YOUR PERSONAL INFORMATION WITH US, YOU ARE CONSENTING TO THE PROCESSING OF YOUR PERSONAL INFORMATION AS DESCRIBED IN THIS PRIVACY NOTICE.

#### The Way Toro Uses Information

Toro may use your personal information to process warranty claims, to contact you in the event of a product recall and for any other purpose which we tell you about. Toro may share your information with Toro's affiliates, dealers or other business partners in connection with any of these activities. We will not sell your personal information to any other company. We reserve the right to disclose personal information in order to comply with applicable laws and with requests by the appropriate authorities, to operate our systems properly or for our own protection or that of other users.

#### Retention of your Personal Information

We will keep your personal information as long as we need it for the purposes for which it was originally collected or for other legitimate purposes (such as regulatory compliance), or as required by applicable law.

#### Toro's Commitment to Security of Your Personal Information

We take reasonable precautions in order to protect the security of your personal information. We also take steps to maintain the accuracy and current status of personal information.

#### Access and Correction of your Personal Information

If you would like to review or correct your personal information, please contact us by email at [legal@toro.com](mailto:legal@toro.com).

### Australian Consumer Law

Australian customers will find details relating to the Australian Consumer Law either inside the box or at your local Toro Dealer.



# The Toro Warranty and The Toro GTS Starting Guarantee

Residential Products

## Conditions and Products Covered

The Toro Company and its affiliate, Toro Warranty Company, pursuant to an agreement between them, jointly promise to repair for the original purchaser<sup>1</sup> the Toro Product listed below if defective in materials or workmanship or if the Toro GTS (Guaranteed to Start) engine will not start on the first or second pull, provided the routine maintenance required in the *Operator's Manual* have been performed.

The following time periods apply from the date of purchase:

Products	Warranty Period
Walk Power Mowers	
• Cast Deck	5 years Residential Use <sup>2</sup> 90 Days Commercial Use
• Engine	5 years GTS Guarantee, Residential Use <sup>3</sup>
• Battery	2 years
• Steel Deck	2 years Residential Use <sup>2</sup> 30 Days Commercial Use
• Engine	2 years GTS Guarantee, Residential Use <sup>3</sup>
TimeMaster Mowers	
• Engine	3 years Residential Use <sup>2</sup> 90 Days Commercial Use
• Battery	3 years GTS Guarantee, Residential Use <sup>3</sup>
• Battery	2 years
Electric Hand Held Products	2 years Residential Use <sup>2</sup> No Warranty for Commercial Use
Snowthrowers	
• Single Stage	2 years Residential Use <sup>2</sup> 45 Days Commercial Use
• Engine	2 years GTS Guarantee, Residential Use <sup>3</sup>
• Two Stage	3 years Residential Use <sup>2</sup> 45 Days Commercial Use
• Chute, chute deflector and impeller housing cover	Lifetime (original owner only) <sup>5</sup>
Electric Snowthrowers	2 years Residential Use <sup>2</sup> No Warranty for Commercial Use
All Ride-On Units Below	
• Engine	See engine manufacturer's warranty <sup>4</sup>
• Battery	2 years Residential Use <sup>2</sup>
• Attachments	2 years Residential Use <sup>2</sup>
DH Lawn & Garden Tractors	2 years Residential Use <sup>2</sup> 30 Days Commercial Use
XLS Lawn & Garden Tractors	3 years Residential Use <sup>2</sup> 30 Days Commercial Use
TimeCutter	3 years Residential Use <sup>2</sup> 30 Days Commercial Use
TITAN Mowers	
• Frame	3 years or 240 hours <sup>5</sup> Lifetime (original owner only) <sup>6</sup>

<sup>1</sup>Original Purchaser means the person who originally purchased the Toro Product.

<sup>2</sup>Residential use means use of the product on the same lot as your home. Use at more than one location is considered commercial use and the commercial use warranty would apply.

<sup>3</sup>The Toro GTS Starting Guarantee does not apply when the product is used commercially.

<sup>4</sup>Some engines used on Toro Products are warranted by the engine manufacturer.

<sup>5</sup>Whichever occurs first.

<sup>6</sup>Lifetime Frame Warranty - If the main frame, consisting of the parts welded together to form the tractor structure that other components such as the engine are secured to, cracks or breaks in normal use, it will be repaired or replaced, at Toro's option, under warranty at no cost for parts and labor. Frame failure due to misuse or abuse and failure or repair required due to rust or corrosion are not covered.

Warranty may be denied if the hour meter is disconnected, altered, or shows signs of being tampered with.

## Owner Responsibilities

You must maintain your Toro Product by following the maintenance procedures described in the *Operator's Manual*. Such routine maintenance, whether performed by a dealer or by you, is at your expense.

## Instructions for Obtaining Warranty Service

If you think that your Toro Product contains a defect in materials or workmanship, follow this procedure:

1. Contact your seller to arrange service of the product. If for any reason it is impossible for you to contact your seller, you may contact any Toro Authorized Distributor to arrange service. See attached Distributor List.
2. Bring the product and your proof of purchase (sales receipt) to the servicing outlet. If for any reason you are dissatisfied with the servicing outlet's analysis or with the assistance provided, contact us at:

Toro Customer Care Department, RLC Division  
Toro Warranty Company  
8111 Lyndale Avenue South  
Bloomington, MN 55420-1196  
001-952-948-4707

## Items and Conditions Not Covered

There is no other express warranty except for special emission system coverage and engine warranty coverage on some products. This express warranty does not cover the following:

- Cost of regular maintenance service or parts, such as filters, fuel, lubricants, oil changes, spark plugs, air filters blade sharpening or worn blades, cable/linkage adjustments, or brake and clutch adjustments
- Components failing due to normal wear
- Any product or part which has been altered or misused or neglected and requires replacement or repair due to accidents or lack of proper maintenance
- Pickup and delivery charges
- Repairs or attempted repairs by anyone other than an Authorized Toro Service Dealer
- Repairs necessary due to failure to follow recommended fuel procedure (consult *Operator's Manual* for more details)
  - Removing contaminants from the fuel system is not covered
  - Use of old fuel (more than one month old) or fuel which contains more than 10% ethanol or more than 15% MTBE
  - Failure to drain the fuel system prior to any period of non-use over one month
- Repairs or adjustments to correct starting difficulties due to the following:
  - Failure to follow proper maintenance procedures or recommended fuel procedure
  - Rotary mower blade striking an object
- Special operational conditions where starting may require more than two pulls:
  - First time starts after extended period of non-use over three months or seasonal storage
  - Cool temperature starts such as those found in early spring and late autumn
  - Improper starting procedures - if you are having difficulty starting your unit, please check the *Operator's Manual* to ensure that you are using the correct starting procedures. This can save an unnecessary visit to an Authorized Toro Service Dealer.

## General Conditions

The purchaser is covered by the national laws of each country. The rights to which the purchaser is entitled with the support of these laws are not restricted by this warranty.