



Count on it.

Parts Catalog

**Z Master[®] Professional 6000
Series Riding Mower**

**with 132cm TURBO FORCE[®] Side Discharge
Mower**

Model No. 74919TE—Serial No. 314000001 and Up



Ordering Replacement Parts

To order replacement parts, please supply the part number, the quantity, and the description of each part desired.

Understanding Reference Numbers

Each identified part in an illustration has a reference number. The reference number for a part also appears in the parts list, along with other information about the part.

This catalog uses two special reference number formats, one to indicate parts in a service assembly and another to indicate the quantity of a given part in an illustration.

Service Assembly Reference Numbers

Parts in service assemblies have reference numbers in the form a:b. The a represents the reference number of the entire service assembly and the b represents a sequential number unique to each part within the service assembly.

For example, a wheel assembly might be identified by reference number 6, the tire by 6:1, the valve by 6:2, and the wheel by 6:3. When you order the assembly identified by reference number 6, you receive all parts identified by reference numbers 6:1, 6:2, and 6:3. However, you may also order any part individually. Reference numbers of this type appear in illustration and in parts lists.

Reference Numbers Indicating Quantity

In an illustration, if a reference number indicates more than one part, the reference number has the form nX y. The n represents the quantity of the part, the X is the multiplication symbol, and the y represents the reference number.

For example, in an illustration, the reference number 2X 37 means that two of the parts identified by reference number 37 are indicated.

List of Abbreviations

AR: as required	HLH: hex lag head	PTO: power-take-off
ASM: assembly	HOC: height-of-cut	RH: right hand
BBC: blade brake control	HSBH: hex socket button head	ROPS: roll-over protection system
BHTF: button head thread forming	HSFH: hex socket flat head	RRB: rear roller brush
CARR: carriage	HSH: hex socket head	SFH: slotted fillister head
CCW: counter clockwise	HWH: hex washer head	SHH: slotted hex head
CW: clockwise	HWHTF: hex washer head thread forming	SHWH: slotted hex washer head
DEG: degrees	HYD: hydraulic	SPH: slotted pan head
DPA: Dual Point Adjustment	LH: left hand	SQH: square head
ECM: electronic control module	LP: Liquefied Petroleum Gas	SRH: slotted round head
EXT: external	LPG: Liquefied Petroleum Gas	STD: standard
FH: flat head	NI: nylon insert	TAP: self tapping
GA: gauge	NPTF: national pipe thread fine	TTH: torx truss head
HD: heavy-duty	PFH: phillips flat head	
HF: hex flange	PPH: phillips pan head	
HH: hex head	PPHTF: phillips pan head thread forming	
HHF: hex head flange	PRH: phillips round head	
HHFTF: hex head flange thread forming	PTH: phillips truss head	
HJ: hex jam		

Contents

Frame, Caster and Z Stand Assembly	4
Roll-Over Protection System Assembly No. 116-0232.....	6
Caster Wheel and Fork Assembly	8
Z Stand Assembly	10
Hydraulic Pump, Idler and Belt Assembly.....	12
Pump Idler Assembly No. 116-1255	14
LH Hydro Assembly No. 116-6411	16
RH Hydro Assembly No. 116-6412	18
Rear Wheel and Park Brake Assembly.....	20
Parking Brake Handle Assembly No. 116-7551	22
Fuel Tank Mounting Assembly	24
Fuel Tank Assembly No. 116-3979	26
Seat Mounting Assembly	28
Seat Assembly No. 125-3107	30
Motion Control Assembly	32
Fender, Console and Control Assembly	34
LH Console Assembly No. 115-7403	36
RH Console Assembly No. 115-7402	38
Electrical Assembly	40
Deck Lift Assembly.....	42
Height-of-Cut Assembly No. 117-3842.....	44
Engine, Clutch and Muffler Assembly	46
Deck Decal Assembly	48
Deck Decal Assembly No. 117-3809.....	50
Idler Assembly	52
Spindle Assembly No. 119-8560	54
Rubber Deflector Assembly No. 108-2792.....	56
Attachments and Accessories	58

Frame, Caster and Z Stand Assembly

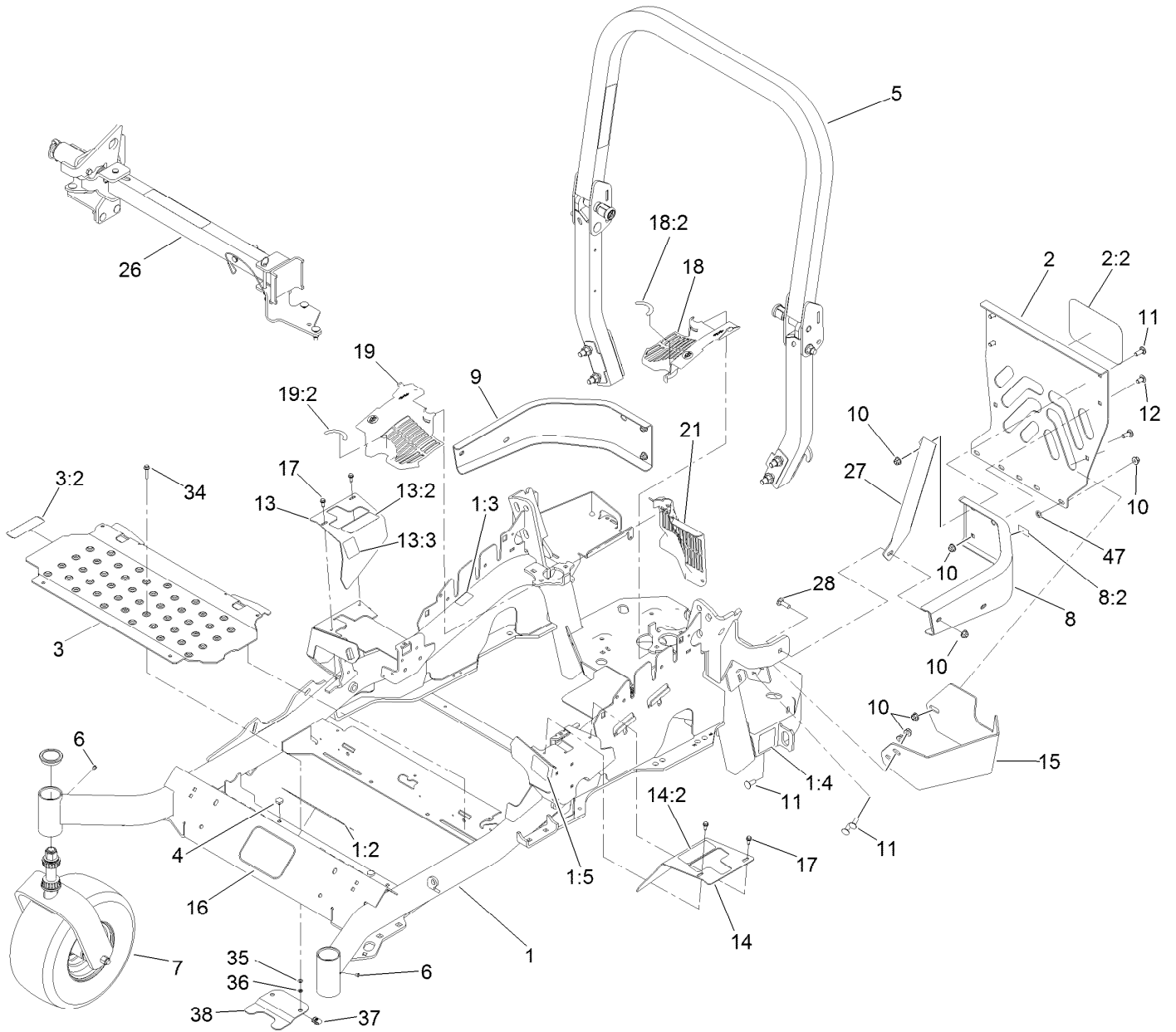

Frame, Caster and Z Stand Assembly (continued)

<i>Ref.</i>	<i>Part Number</i>	<i>Qty.</i>	<i>Description</i>	<i>Ref.</i>	<i>Part Number</i>	<i>Qty.</i>	<i>Description</i>
1	116-6368	1	Main Frame ASM	13:2	99-8936	1	Decal-Control, Motion
1:2	117-3888	1	Decal-Danger Slope W/ROPS	13:3	116-5988	1	Decal-Park Brake, Ce
1:3	106-5517	2	Decal-Warning, Hot Surface	14	117-3831	1	LH Motion Control Cover ASM
1:4	106-2655	2	Decal-Hazard, Pinched Finger	14:2	99-8936	1	Decal-Control, Motion
1:5	117-3864	1	Decal-Fuel Fill, Ce	15	117-0908-03	1	Guard-Muffler
2	115-7410	1	Rear Guard ASM	16	68-3640	1	Decal
2:2	67-7320	1	Decal	17	32144-10	4	Screw-HWH
3	117-0915	1	Floorpan ASM	18	117-3838	1	LH Hydro Guard ASM
3:2	112-9028	1	Decal-Cover Missing	18:2	117-3811	1	Decal-Hydro Oil
4	1-513658	2	Bumper	19	117-3839	1	RH Hydro Guard ASM
5	116-0232	1	ROPS ASM	19:2	117-3811	1	Decal-Hydro Oil
6	1-811010	2	Plug	21	109-9058	1	Guard-Hydro, Rear RH
7		2	Caster Wheel ASM ●	26		1	Z Stand ASM ●
8	117-3829	1	LH Rear Bumper ASM	27	117-0903-03	1	Strap
8:2	106-5517	1	Decal-Warning, Hot Surface	28	3231-25	1	Bolt-CARR
9	116-0057-03	1	Bumper-RH	34	3234-21	2	Screw-HHF
10	104-8301	11	Nut-Flange, NI	35	3256-60	2	Washer-Flat
11	3231-22	7	Screw-CARR	36	106-8737	2	Nut-Retainer
12	3231-21	3	Screw-CARR	37	107069	2	Clip
13	116-5898	1	RH Motion Control Cover ASM	38	119-0395-03	1	Adapter-Captive
				47	107-3154	2	Nut-Push

● Not serviced separately

Roll-Over Protection System Assembly No. 116-0232

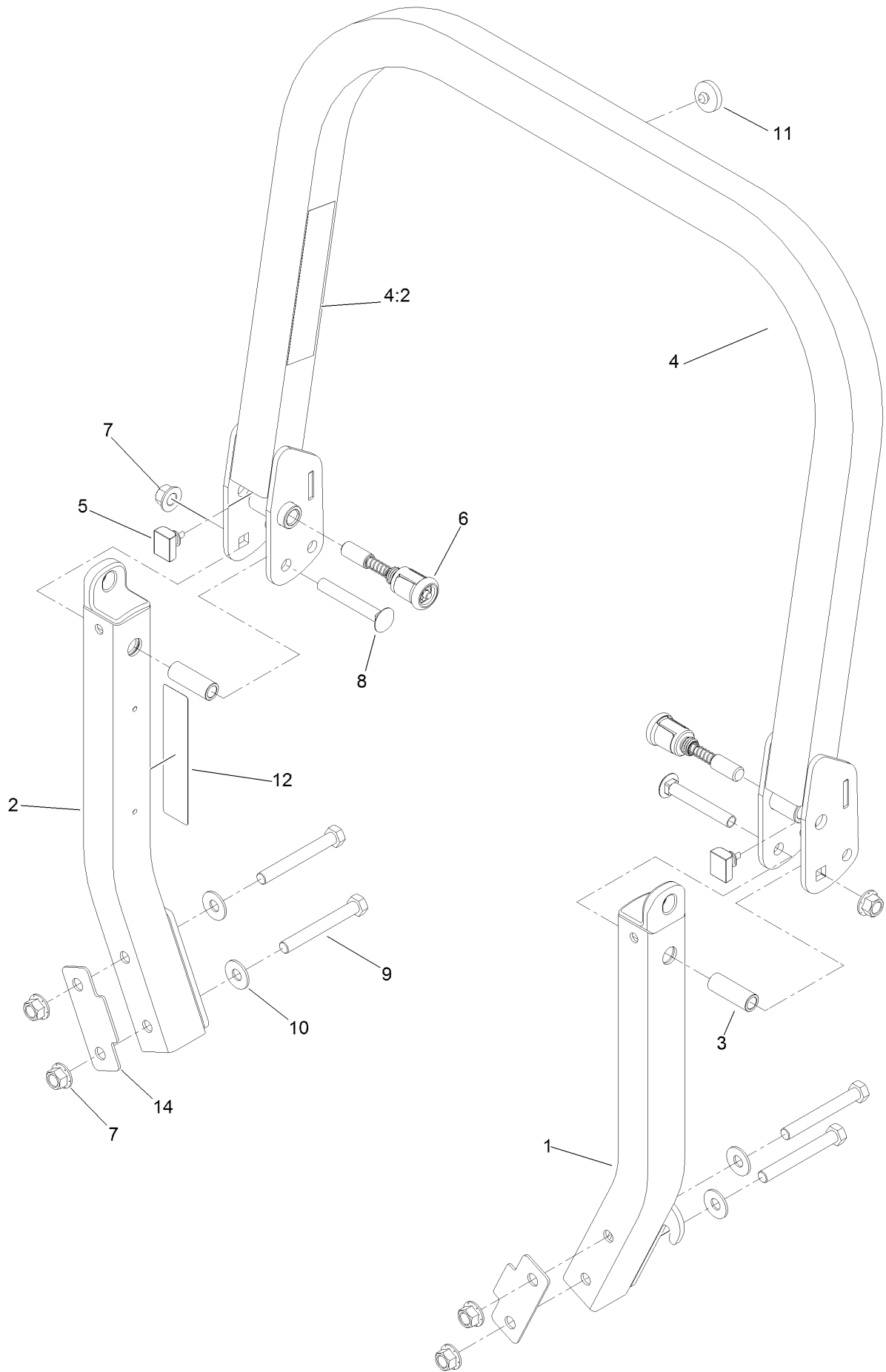

Roll-Over Protection System Assembly No. 116-0232 (continued)

<i>Ref.</i>	<i>Part Number</i>	<i>Qty.</i>	<i>Description</i>	<i>Ref.</i>	<i>Part Number</i>	<i>Qty.</i>	<i>Description</i>
1		1	Leg-ROPS, LH ●	7	99-5107	6	Nut-Lock
2		1	Leg-ROPS, RH ●	8	3233-10	2	Screw-CARR
3	109-6653	2	Spacer	9	325-17	4	Screw-HH
4		1	Upper ROPS ASM ●	10	109-9505	4	Washer-Spring
4:2	107-3069	1	Decal-Warning, Folding ROPS	11	109-9233	1	Bumper-Push-In, Rubber
5	109-5337	2	Bumper-ROPS	12	117-0346	1	Decal-Caution, Fuel Vent
6	116-0104	2	Pin-Spring	14	116-0960	2	Spacer

● Not serviced separately

Caster Wheel and Fork Assembly

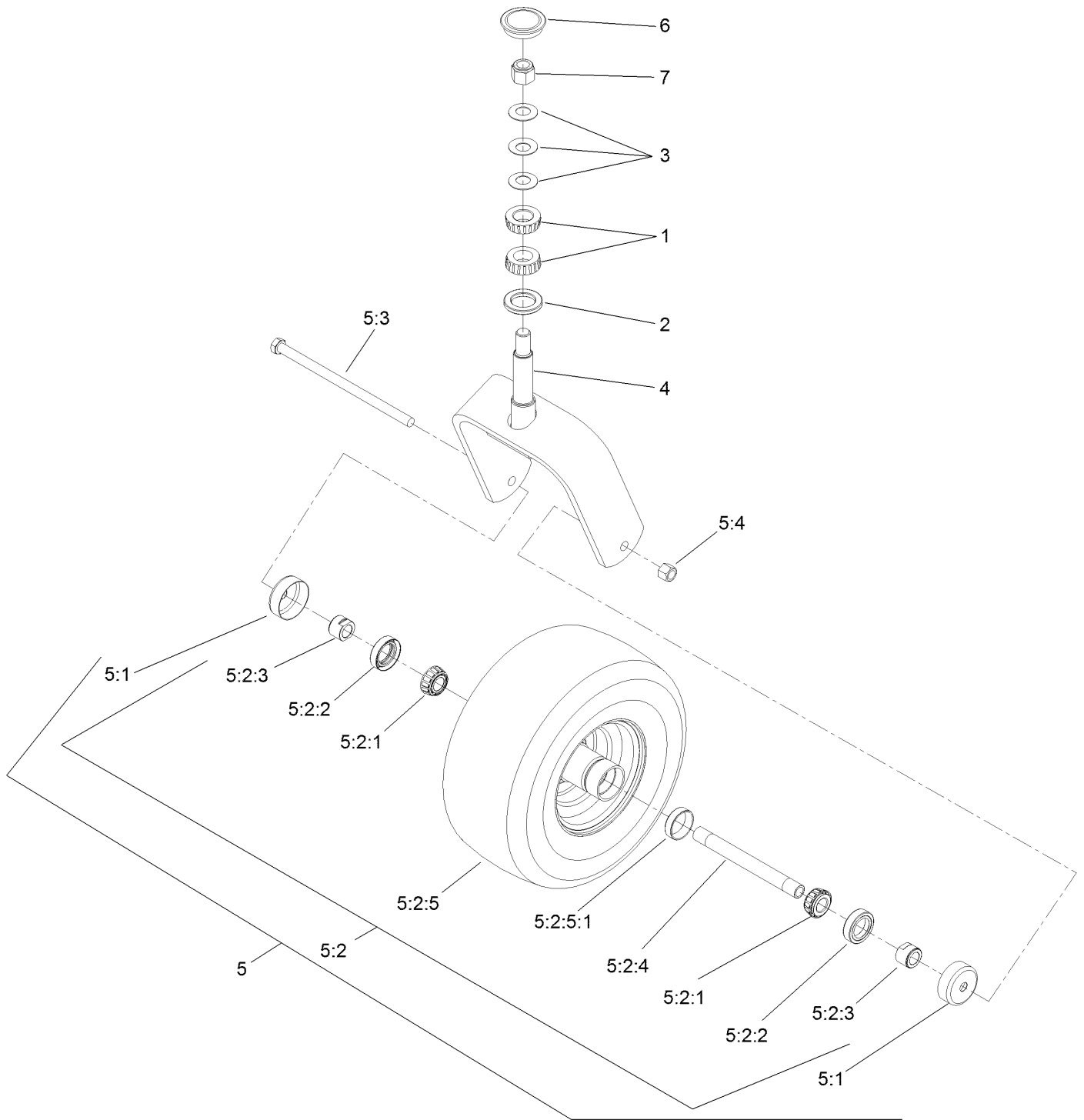

Caster Wheel and Fork Assembly (continued)

<i>Ref.</i>	<i>Part Number</i>	<i>Qty.</i>	<i>Description</i>	<i>Ref.</i>	<i>Part Number</i>	<i>Qty.</i>	<i>Description</i>
1	1-543509	2	Bearing-Roller, Tapered	5:2:3	103-3051	2	Spacer-Nut ■
2	116-5647	1	Seal-Grease	5:2:4	103-5156	1	Axle-Caster
3	1-633508	3	Washer-Bellville	5:2:5		1	Wheel And Tire ASM ●
4	116-6707-01	1	Caster	5:2:5:1	1-633584	1	Bearing-Cup
5	109-9127	1	Wheel And Tire ASM	5:3	325-39	1	Screw-HH
5:1	103-2768	2	Guard-Seal	5:4	3296-23	1	Nut-Lock, NI
5:2		1	Wheel And Tire ASM ●	6	103-4882	1	Cap-Grease
5:2:1	1-633585	2	Bearing-Cone, Taper	7	3296-51	1	Nut-Lock, NI
5:2:2	103-0063	2	Seal-Caster				

● Not serviced separately

■ Use Pro-Lock, Nut Type (P/N 1-840022, .5ml tube) on threads.

Z Stand Assembly

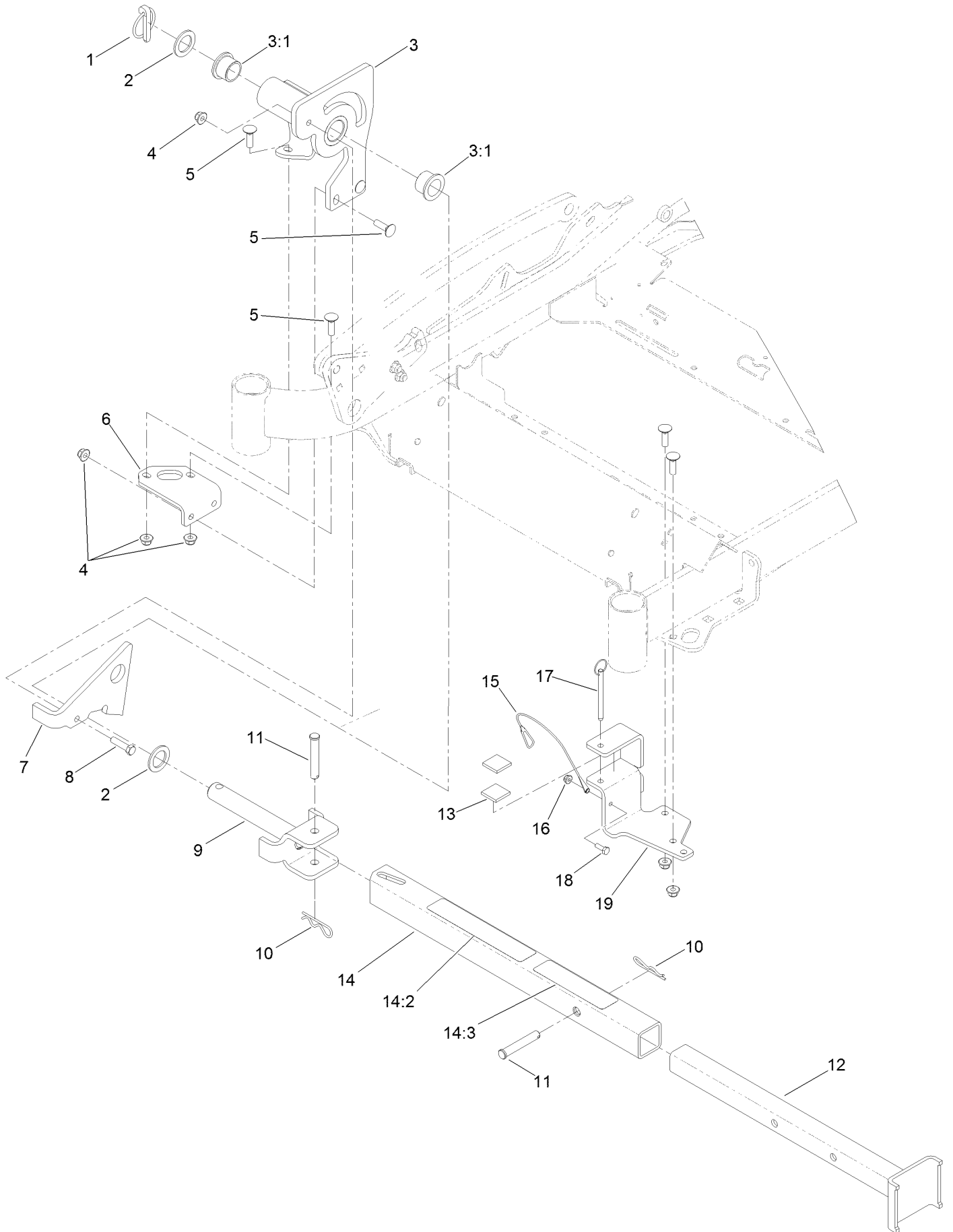

Z Stand Assembly (continued)

<i>Ref.</i>	<i>Part Number</i>	<i>Qty.</i>	<i>Description</i>	<i>Ref.</i>	<i>Part Number</i>	<i>Qty.</i>	<i>Description</i>
1	283-71	1	Pin-Lynch	11	283-55	2	Pin-Clevis
2	3-6781	2	Washer-Thrust	12	115-3631-01	1	Tube-Inner
3	115-3635	1	Z Stand Pivot ASM	13	115-3613	2	Cushion-Rubber
3:1	94-1291	2	Bushing	14	115-3634	1	Outer Tube ASM
4	104-8301	8	Nut-Flange, NI	14:2	106-7464	1	Decal-Z Stand
5	3231-25	7	Bolt-CARR	14:3	107-3969	1	Decal-Warning
6	115-3619-01	1	Bracket-Mount, Pivot	15	100-9385	1	Lanyard-Nylon
7	100-9686-01	1	Bracket-Latch	16	104-7201	1	Nut-HF
8	323-8	1	Screw-HH	17	105-1647	1	Pin-Hitch, Cotterless
9	100-9692-01	1	Pin-Pivot	18	321-4	1	Screw-HH
10	3290-355	2	Pin-Hair	19	115-3625-01	1	Cradle-Z Stand

Hydraulic Pump, Idler and Belt Assembly

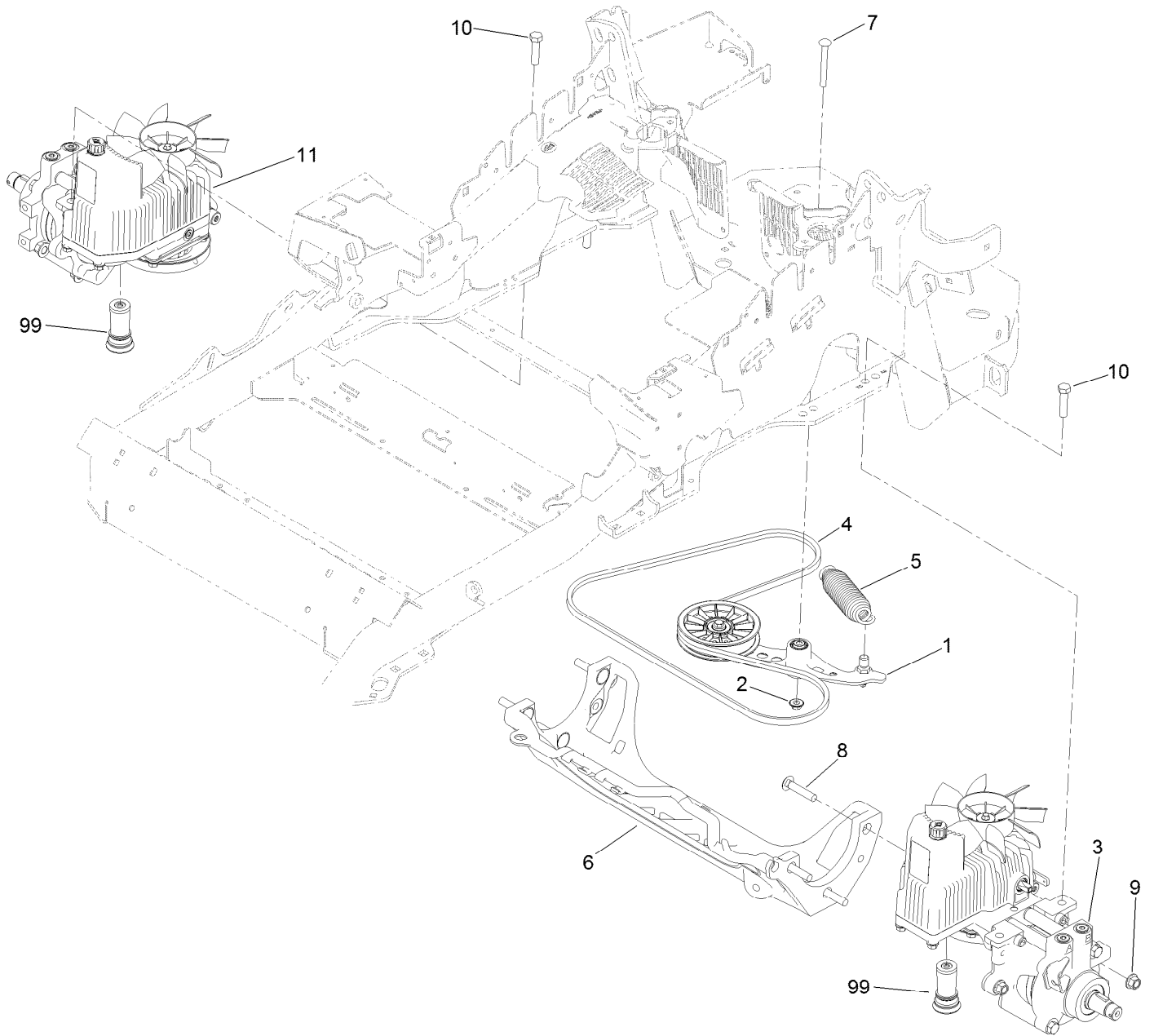

Hydraulic Pump, Idler and Belt Assembly (continued)

<i>Ref.</i>	<i>Part Number</i>	<i>Qty.</i>	<i>Description</i>	<i>Ref.</i>	<i>Part Number</i>	<i>Qty.</i>	<i>Description</i>
1	116-1255	1	Pump Idler ASM	9	99-5107	6	Nut-Lock
2	109-6658	1	Nut-Flange, NI	10	325-8	4	Screw-HH
3	116-6411	1	LH Hydro ASM (12Cc W/Check)	11	116-6412	1	RH Hydro ASM (12Cc W/Check)
4	109-3388	1	Belt	99	114-4713	1	Hypr-Oil 500 (Quart) ●
5	116-6317	1	Spring-Extension	99	114-4714	1	Hypr-Oil 500 (Gallon) ●
6	109-9375	1	Cradle-Hydro	99	114-4715	1	Hypr-Oil 500-5 (5 Gallon) ●
7	116-1502	1	Bolt-Shoulder, Carriage	99	117-0390	1	Filter-Hydro
8	126-0095	6	Screw-CARR				

● Not illustrated

Pump Idler Assembly No. 116-1255



Pump Idler Assembly No. 116-1255 (continued)

<i>Ref.</i>	<i>Part Number</i>	<i>Qty.</i>	<i>Description</i>	<i>Ref.</i>	<i>Part Number</i>	<i>Qty.</i>	<i>Description</i>
2	43-0940	1	Spacer	8	323-8	1	Screw-HH
3	103-3504	2	Bearing-Spherical	9	32120-10	2	Ring-Snap
4	103-3505	1	Seal-Double Lip	10	302-19	1	Fitting-Grease
5	103-3506	1	Seal-Single Lip	11	109-8076	1	Pulley-Idler
6	109-6658	1	Nut-Flange, NI	12	116-3467	1	Pin-Spring, Anchor
7	106-7159	2	O-Ring				

LH Hydro Assembly No. 116-6411

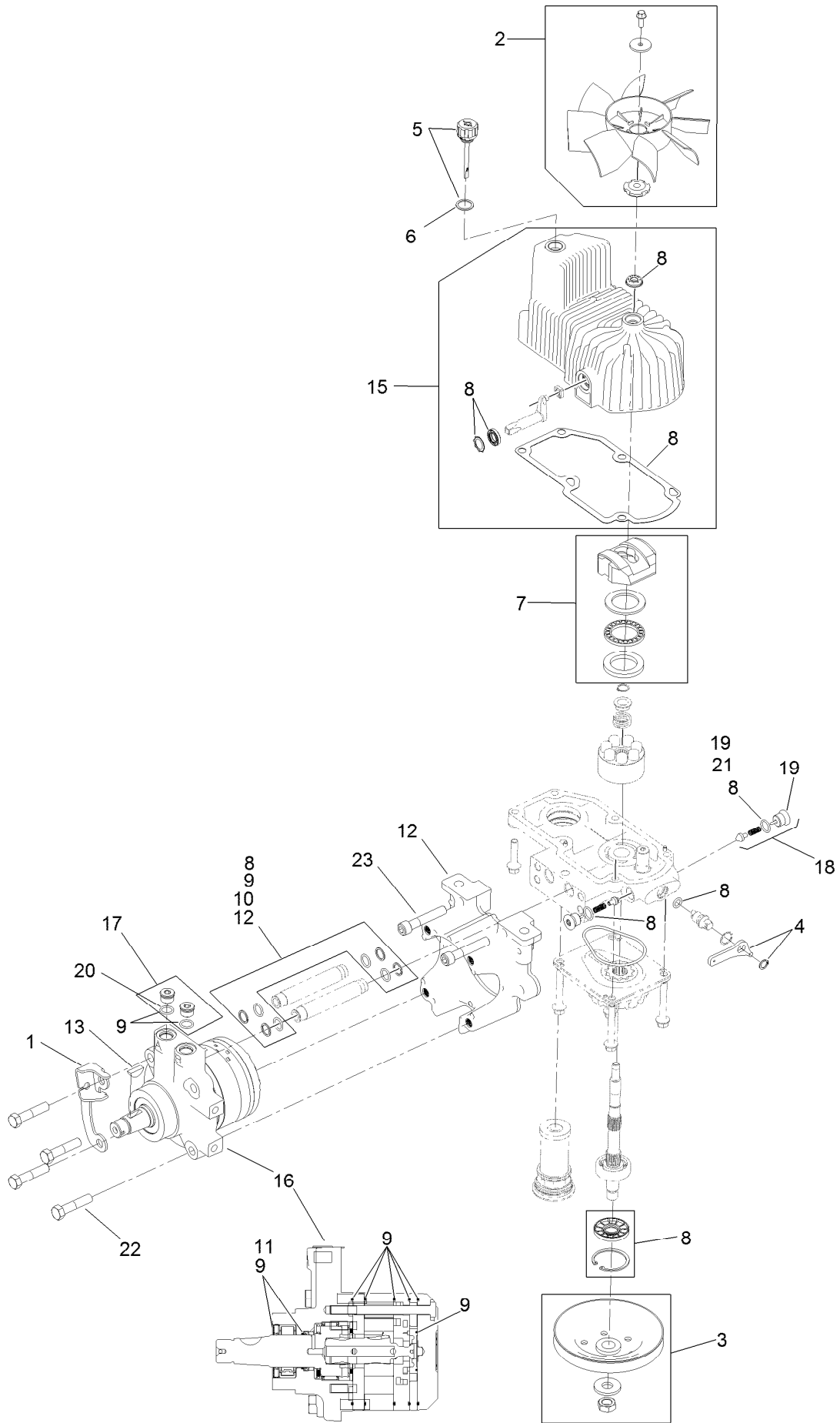

LH Hydro Assembly No. 116-6411 (continued)

<i>Ref.</i>	<i>Part Number</i>	<i>Qty.</i>	<i>Description</i>	<i>Ref.</i>	<i>Part Number</i>	<i>Qty.</i>	<i>Description</i>
1	116-6859	1	Bracket-Anchor, Cable	12	116-5469	1	Nose Cup-Uht
2	116-0233	1	Fan Kit	13	3257-42	1	Key-Woodruff
3	116-0234	1	Pulley Kit	15	116-3287	1	Housing-LH
4	116-0235	1	Handle-Bypass Valve, Hydro	16	116-8915	1	Motor-Hydraulic LH 240Cc
5	116-0236	1	Dipstick-Hydro W/Gasket	17	116-7901	1	Magnetic Plugs Service Kit
6	116-0237	1	Gasket-Dipstick, Hydro	18	116-1630	2	Check Valve ASM
7	116-1367	1	Swash Block Kit	19	116-1631	2	Plug-Check (W/O-Ring)
8	116-1368	1	Pump Seal Kit	20	76-1900	2	O-Ring
9	116-1369	1	Motor Seal Kit	21	116-8662	2	O-Ring-Check Valve
10	116-1370	1	Tube Seal Kit	22	116-8974	4	Screw HH
11	116-1371	1	Output Shaft Seal Kit	23	116-8975	2	Screw-HSH
				99	116-1373	1	Flow Test Kit ●

● Not illustrated

RH Hydro Assembly No. 116-6412

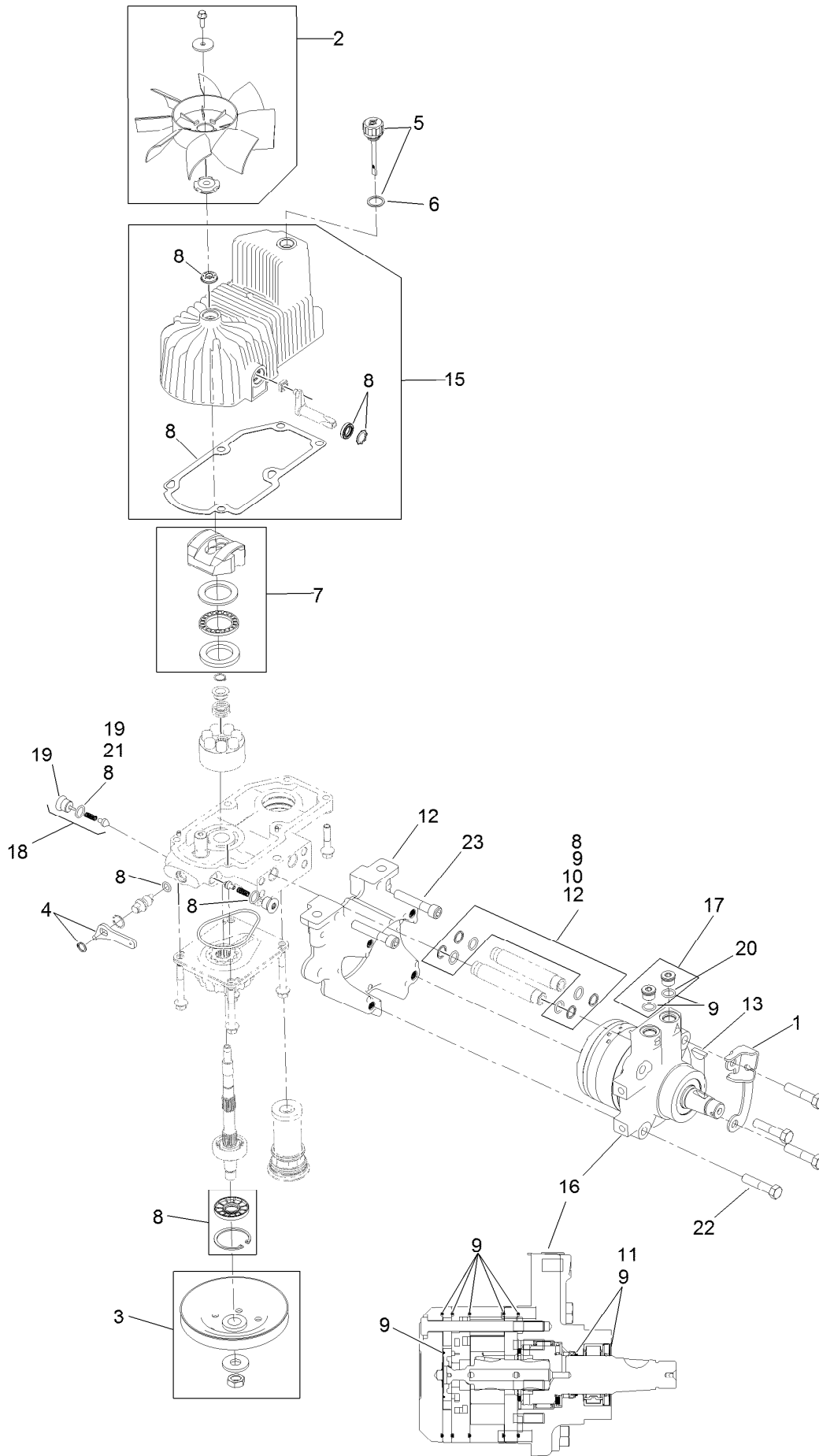

RH Hydro Assembly No. 116-6412 (continued)

<i>Ref.</i>	<i>Part Number</i>	<i>Qty.</i>	<i>Description</i>	<i>Ref.</i>	<i>Part Number</i>	<i>Qty.</i>	<i>Description</i>
1	116-6859	1	Bracket-Anchor, Cable	12	116-5469	1	Nose Cup-Uht
2	116-0233	1	Fan Kit	13	3257-42	1	Key-Woodruff
3	116-0234	1	Pulley Kit	15	116-3288	1	Housing-RH
4	116-0235	1	Handle-Bypass Valve, Hydro	16	116-8916	1	Motor-Hydraulic RH 240Cc
5	116-0236	1	Dipstick-Hydro W/Gasket	17	116-7901	1	Magnetic Plugs Service Kit
6	116-0237	1	Gasket-Dipstick, Hydro	18	116-1630	2	Check Valve ASM
7	116-1367	1	Swash Block Kit	19	116-1631	2	Plug-Check (W/O-Ring)
8	116-1368	1	Pump Seal Kit	20	76-1900	2	O-Ring
9	116-1369	1	Motor Seal Kit	21	116-8662	2	O-Ring-Check Valve
10	116-1370	1	Tube Seal Kit	22	116-8974	4	Screw HH
11	116-1371	1	Output Shaft Seal Kit	23	116-8975	2	Screw-HSH
				99	116-1373	1	Flow Test Kit ●

● Not illustrated

Rear Wheel and Park Brake Assembly

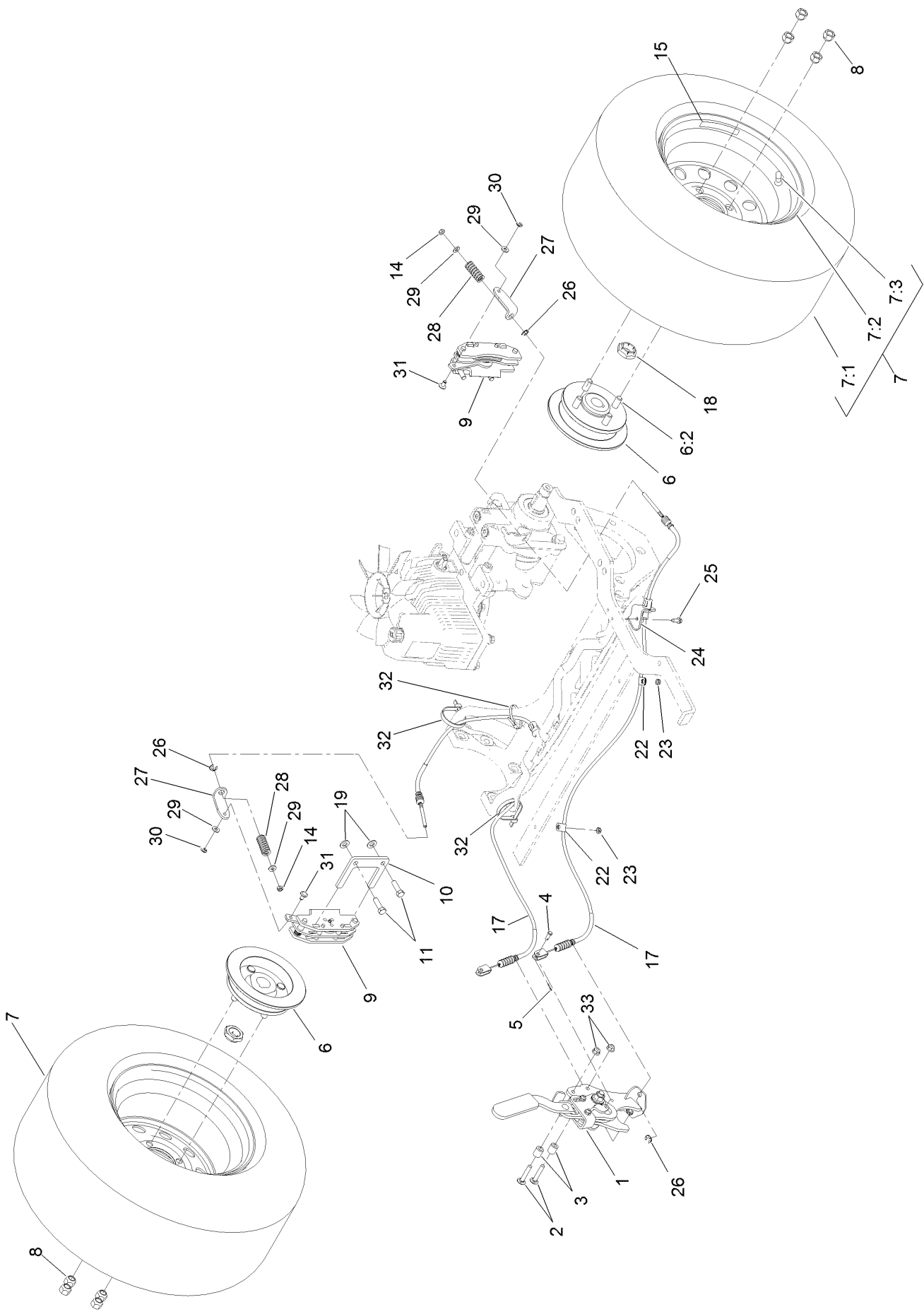

Rear Wheel and Park Brake Assembly (continued)

<i>Ref.</i>	<i>Part Number</i>	<i>Qty.</i>	<i>Description</i>	<i>Ref.</i>	<i>Part Number</i>	<i>Qty.</i>	<i>Description</i>
1	116-7551	1	Brake Handle ASM	15	117-3863	2	Decal-Wheel Hub, Ce
2	116-0629	2	Screw-CARR	17	116-8963	2	Cable-Brake
3	82-6840	2	Spacer	18	116-1399	2	Locknut
4	60-1730	2	Pin-Clevis	19	3256-24	4	Washer-Flat
5	3272-1	2	Pin-Cotter	22	88-7970	2	Clip
6	116-1746	2	Wheel Hub ASM	23	3296-56	2	Nut-Lock, NI
6:2	116-1696	4	Stud-Wheel	24	116-6397	1	Bracket-Cable
7	127-9544	2	Wheel And Tire ASM	25	32144-10	1	Screw-HWH
7:1	127-9523	1	Tire	26	32120-18	4	E-Ring
7:2	109-2875	1	Rim ASM	27	116-6182	2	Bracket-Brake, L
7:3	232-27	1	Stem-Valve	28	116-6347	2	Spring-Die
8	242-50	8	Nut-Lug	29	3256-22	4	Washer-Flat
9	109-2889	2	Caliper-Brake	30	32151-86	2	E-Ring
10	109-0958	2	Plate-Mount, Brake	31	116-6348	2	Pin-Brake
11	92-5727	4	Screw-Lock, Patch	32	3334-945	2	Tie-Cable
14	3296-13	2	Nut-Lock, NI	33	104-8300	2	Nut-Flange, NI

Parking Brake Handle Assembly No. 116-7551

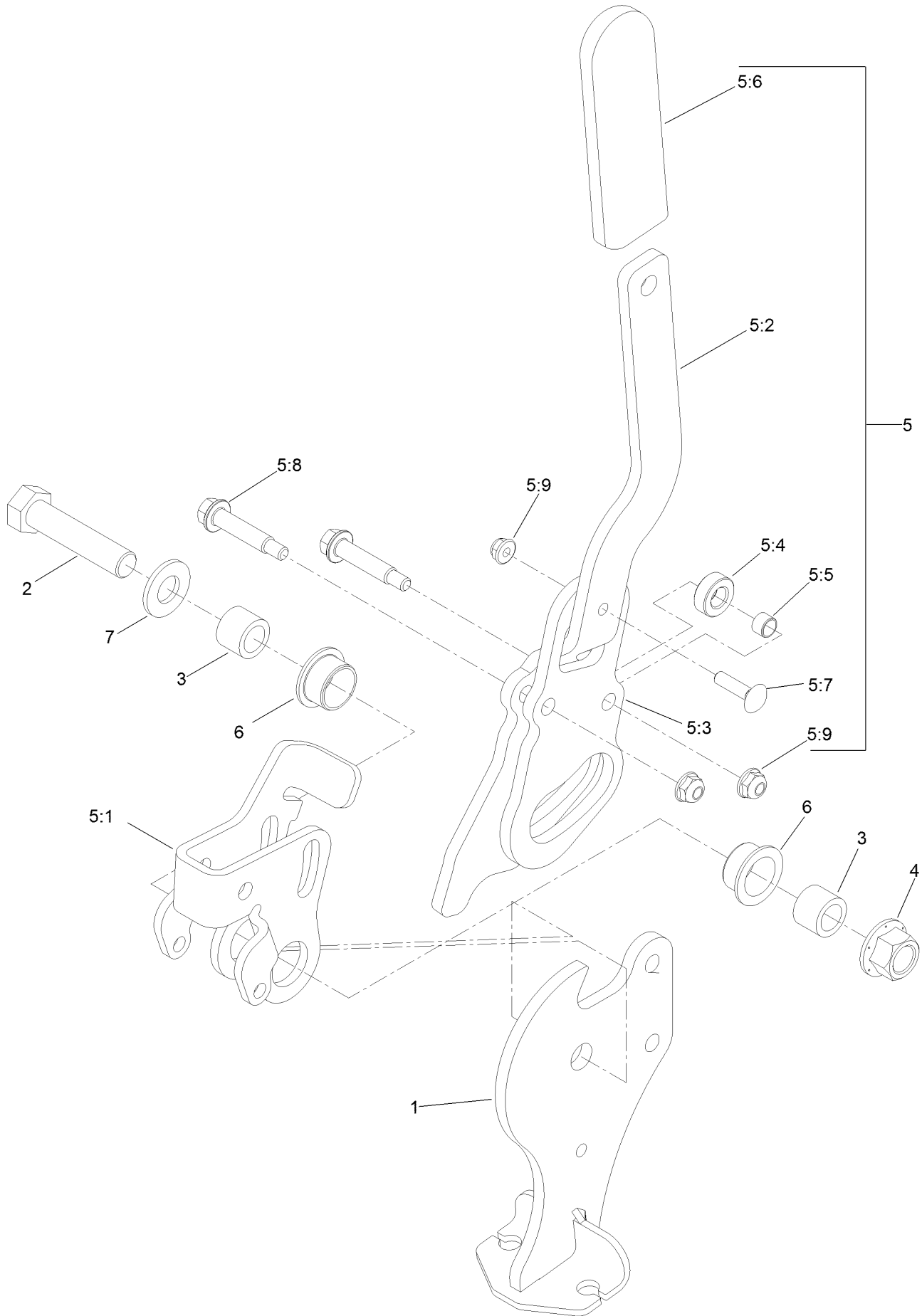

Parking Brake Handle Assembly No. 116-7551 (continued)

<i>Ref.</i>	<i>Part Number</i>	<i>Qty.</i>	<i>Description</i>	<i>Ref.</i>	<i>Part Number</i>	<i>Qty.</i>	<i>Description</i>
1	116-7263	1	Pivot-Brake	5:4	116-6846	1	Roller-Brake
2	325-9	1	Screw-HH	5:5	116-6852	1	Bearing-Sleeve
3	116-5384	2	Spacer	5:6	1-633268	1	Grip-Lever
4	99-5107	1	Nut-Lock	5:7	3229-2	1	Screw-CARR
5	116-6860	1	Handle ASM	5:8	116-6876	2	Screw-Shoulder
5:1	116-6856	1	Bellcrank-Brake	5:9	104-7201	3	Nut-HF
5:2	116-6857	1	Handle-Brake	6	109-8054	2	Bushing-Flange
5:3	116-6858	1	Plate-Handle	7	3256-26	1	Washer-Flat

Fuel Tank Mounting Assembly

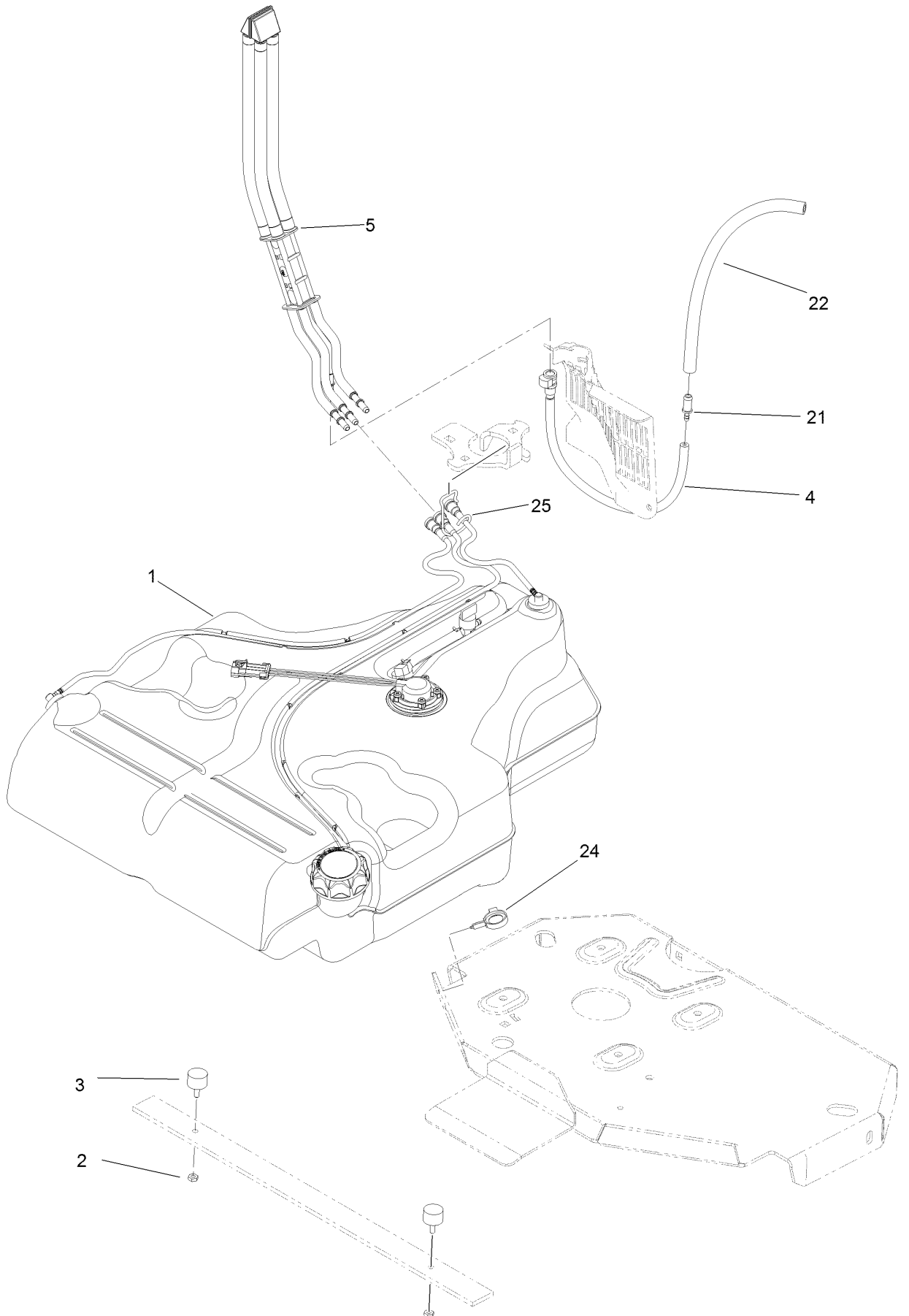

Fuel Tank Mounting Assembly (continued)

<i>Ref.</i>	<i>Part Number</i>	<i>Qty.</i>	<i>Description</i>	<i>Ref.</i>	<i>Part Number</i>	<i>Qty.</i>	<i>Description</i>
1	116-3979	1	Fuel Tank ASM	21	98-2952	1	Fitting-Straight
2	3218-1	2	Nut-Jam	22	116-5087	1	Hose-Fuel
3	116-6380	2	Bumper-Rubber (W/ Stud)	24	105-1853	1	Clamp-Hose
4	116-3977	1	Hose ASM	25	116-6005	1	Retainer-Vapor Line
5	109-9491	1	Fuel Manifold Vent ASM				

Fuel Tank Assembly No. 116-3979

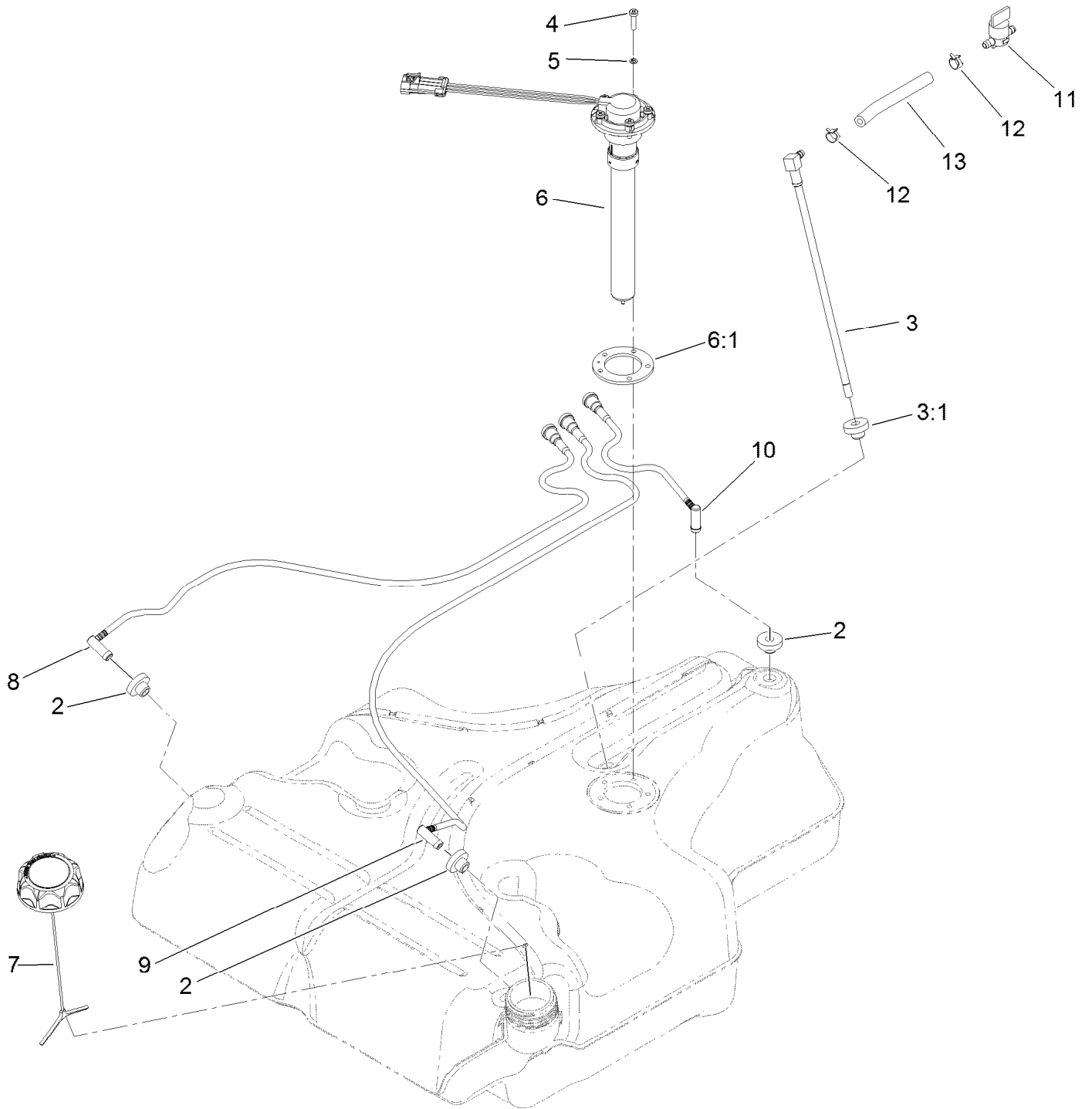

Fuel Tank Assembly No. 116-3979 (continued)

<i>Ref.</i>	<i>Part Number</i>	<i>Qty.</i>	<i>Description</i>	<i>Ref.</i>	<i>Part Number</i>	<i>Qty.</i>	<i>Description</i>
2	46-6560	4	Bushing	8	116-2460	1	RH Vent Line Kit (With Grommet)
3	116-2459	1	Fuel Line Kit (With Grommet)	9	116-2461	1	LH Vent Line Kit (With Grommet)
3:1	46-6560	1	Bushing	10	116-2462	1	Rear Vent Line Kit (With Grommet)
4	9107944	5	Screw-Pan	11	1-603770	1	Valve-Fuel
5	3253-17	5	Washer-Lock	12	2412-98	2	Clamp-Hose
6	116-0003	1	Sender-Fuel Level	13	109-0650	1	Hose-Fuel
6:1	109-9620	1	Gasket-Sender, Fuel				
7	126-1789	1	Cap-Fuel, Ratcheting				

Seat Mounting Assembly

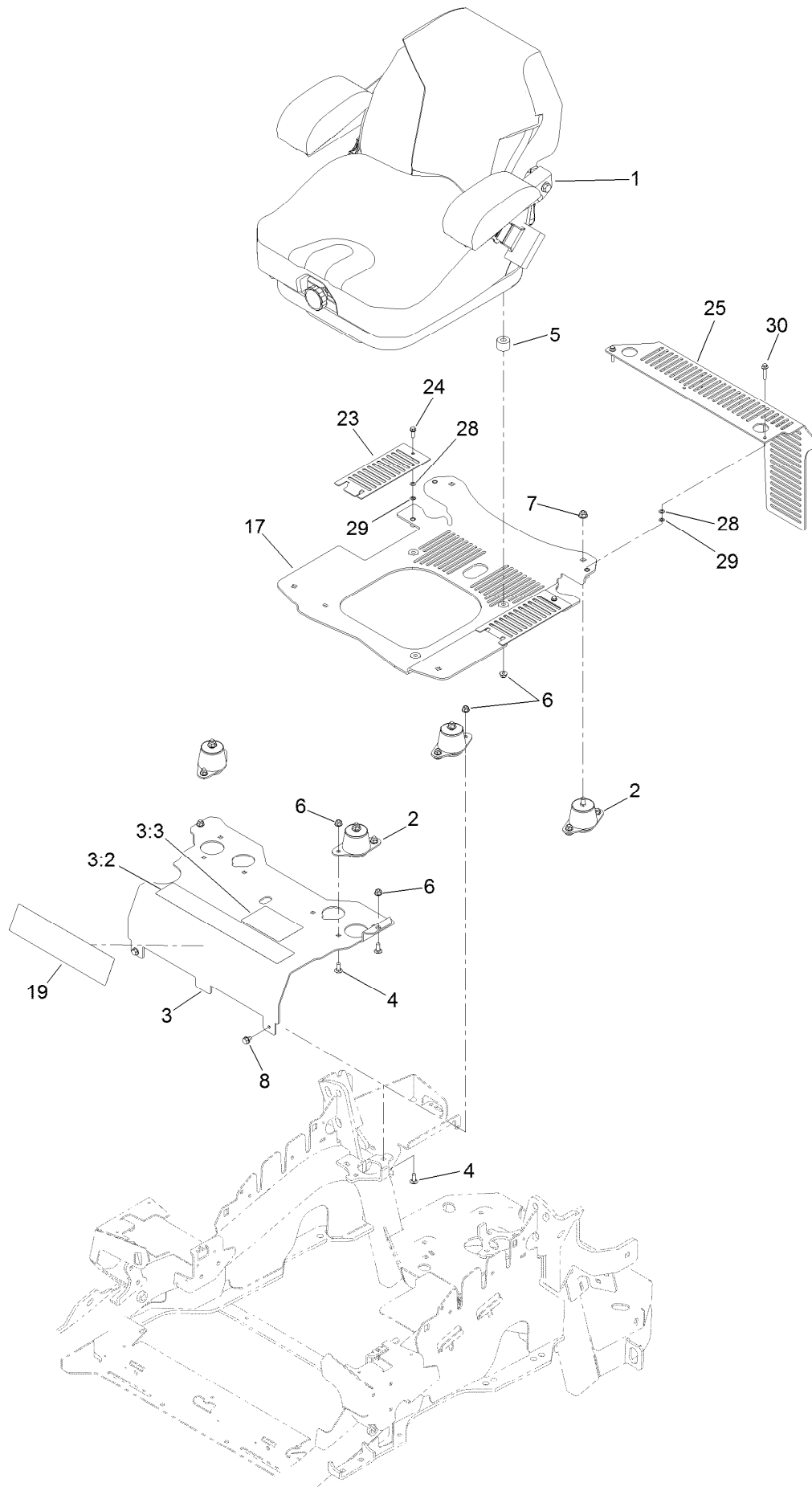

Seat Mounting Assembly (continued)

<i>Ref.</i>	<i>Part Number</i>	<i>Qty.</i>	<i>Description</i>	<i>Ref.</i>	<i>Part Number</i>	<i>Qty.</i>	<i>Description</i>
1	125-3107	1	Suspension Seat ASM	8	9266934	2	Screw
2	109-9034	4	Isolator-Seat	17	117-0910	1	Seat Base ASM
3	116-2324	1	Mount-Seat	19	120-5893	1	Decal
3:2	114-4468	1	Decal-Console	23	117-0901-03	2	Cover
3:3	125-9383	1	Decal-Service Aid	24	32105-15	2	Screw-HWH
4	3230-23	11	Screw-CARR	25	119-4241-03	1	Guard-Ce
5	116-9329	4	Spacer	28	3256-60	4	Washer-Flat
6	104-8300	18	Nut-Flange, NI	29	106-8737	4	Nut-Retainer
7	104-8301	4	Nut-Flange, NI	30	3234-21	2	Screw-HHF

Seat Assembly No. 125-3107

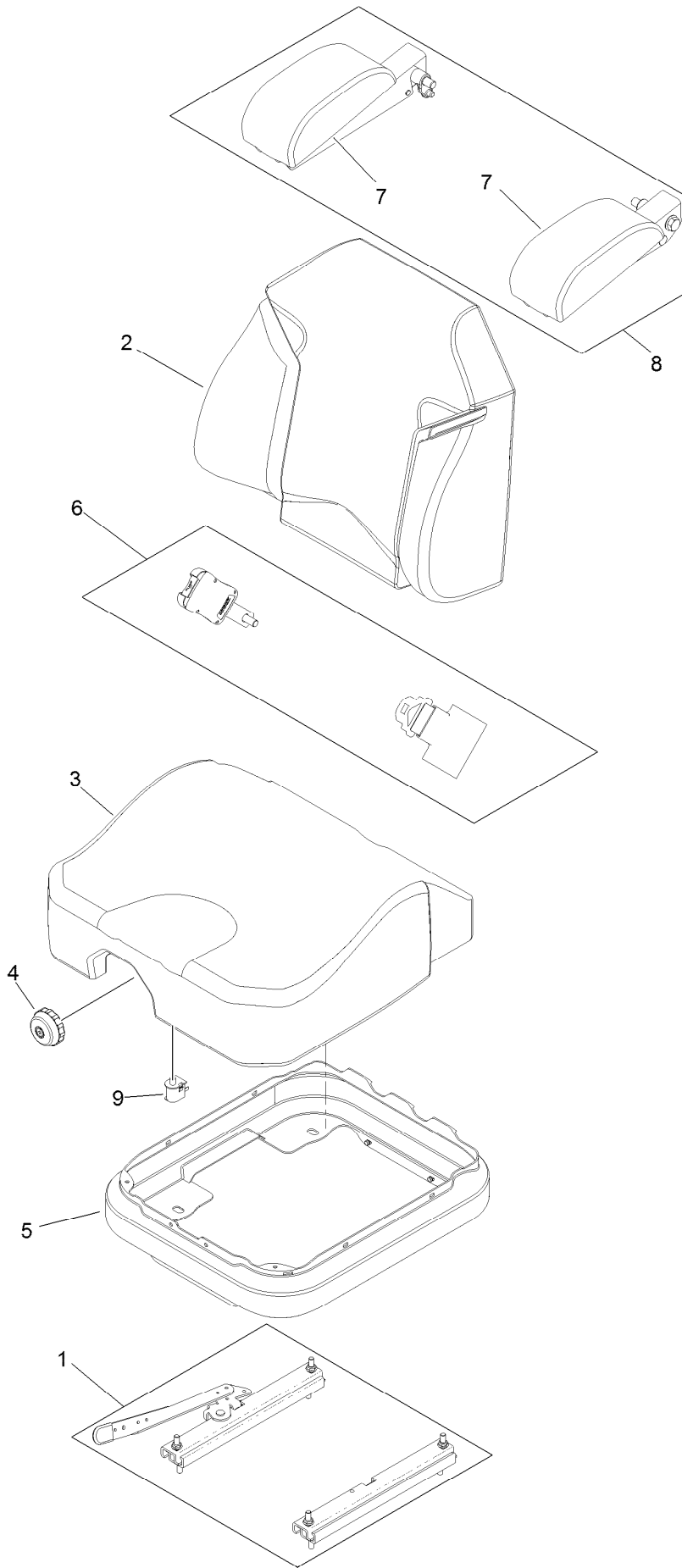

Seat Assembly No. 125-3107 (continued)

<i>Ref.</i>	<i>Part Number</i>	<i>Qty.</i>	<i>Description</i>	<i>Ref.</i>	<i>Part Number</i>	<i>Qty.</i>	<i>Description</i>
1	116-8910	1	Seat Track Set	6	109-9805	1	Seat Belt Kit
2	125-3112	1	Cover-Back	7	109-9802	1	Arm Rest Pad Set
3	125-3111	1	Cover-Cushion	8	109-9803	1	Arm Rest Set
4	116-8911	1	Knob-Adjuster	9	82-2190	1	Switch-Bail
5	116-5659	1	Cover-Suspension Bellows				

Motion Control Assembly

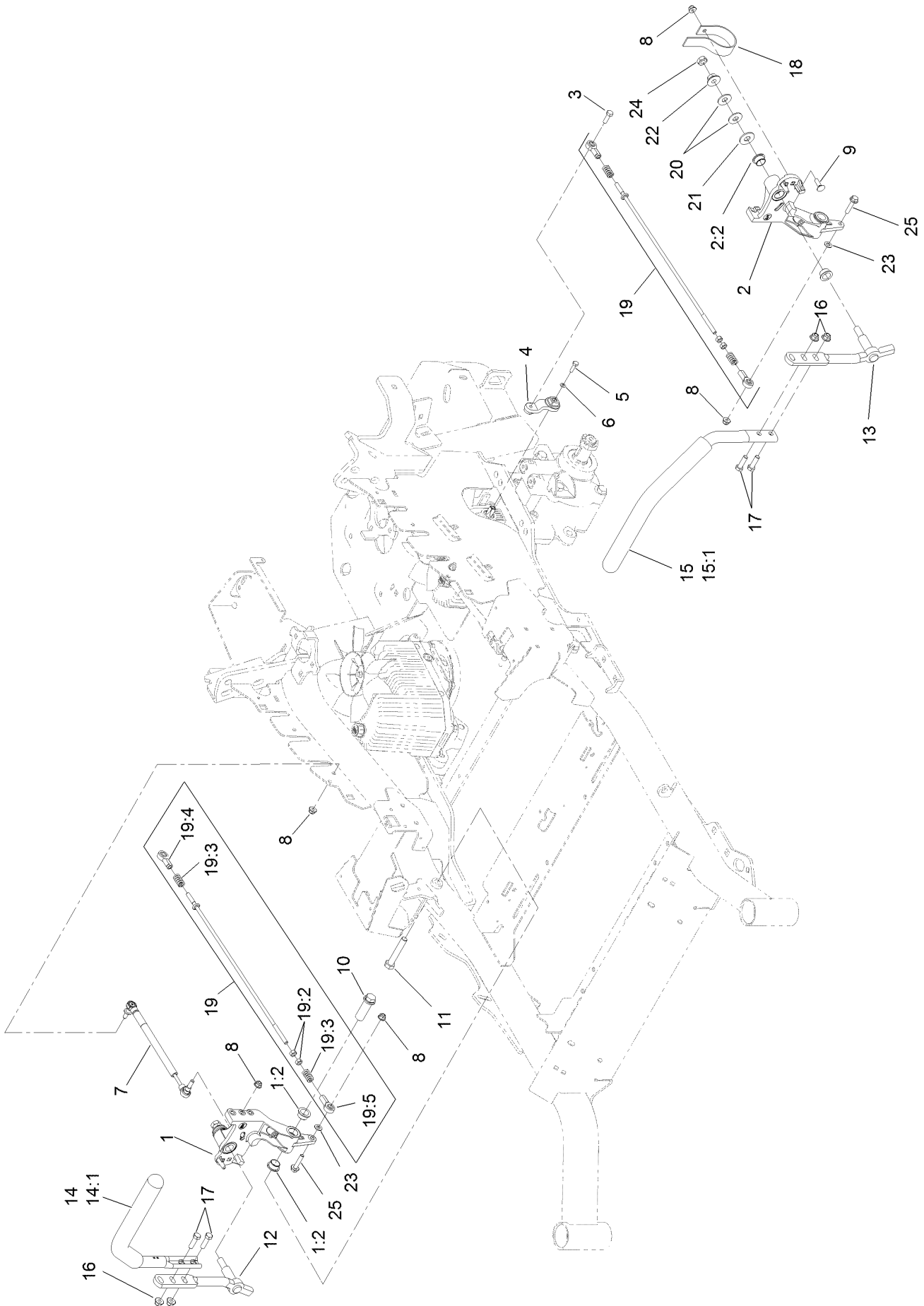

Motion Control Assembly (continued)

<i>Ref.</i>	<i>Part Number</i>	<i>Qty.</i>	<i>Description</i>	<i>Ref.</i>	<i>Part Number</i>	<i>Qty.</i>	<i>Description</i>
1	116-0880	1	RH Motion Control And Bushing ASM	14	109-6589	1	RH Steering Handle ASM
1:2	109-8054	4	Bushing-Flange	14:1	109-5668	1	Grip-Control, Lever
2	116-0881	1	LH Motion Control And Bushing ASM	15	109-6590	1	LH Steering Handle ASM
2:2	109-8054	4	Bushing-Flange	15:1	109-5668	1	Grip-Control, Lever
3	116-0648	2	Screw-HH, Thread Locking ●	16	104-8301	4	Nut-Flange, NI
4	109-4581	2	Arm-Control, Pump	17	323-7	4	Screw-HH
5	9080046	2	Screw-HH ●	18	109-5575	2	Spring-Leaf
6	1-303435	2	Washer-Spring	19	109-8107	2	Pump Linkage Rear ASM
7	116-0027	2	Damper-Control, Motion	19:2	3219-2	2	Nut-Hex
8	104-8300	8	Nut-Flange, NI	19:3	1-323245	2	Spring-Compression
9	3230-2	2	Bolt-CARR	19:4	1-633152	1	Balljoint-LH
10	109-5891	2	Hub-Threaded	19:5	1-543017	1	Balljoint-RH
11	325-12	2	Screw-HH	20	109-9505	4	Washer-Spring
12	116-0039	1	Lever-Control Motion, RH	21	3256-6	2	Washer-Flat
13	116-0040	1	Lever-Control Motion, LH	22	32128-56	2	Nut-HF
				23	3256-23	2	Washer-Flat
				24	3218-5	2	Nut-Jam
				25	115-1794	2	Screw-HHF

● Use Pro-Lock, Nut Type (P/N 1-840022, .5ml tube) on threads.

Fender, Console and Control Assembly

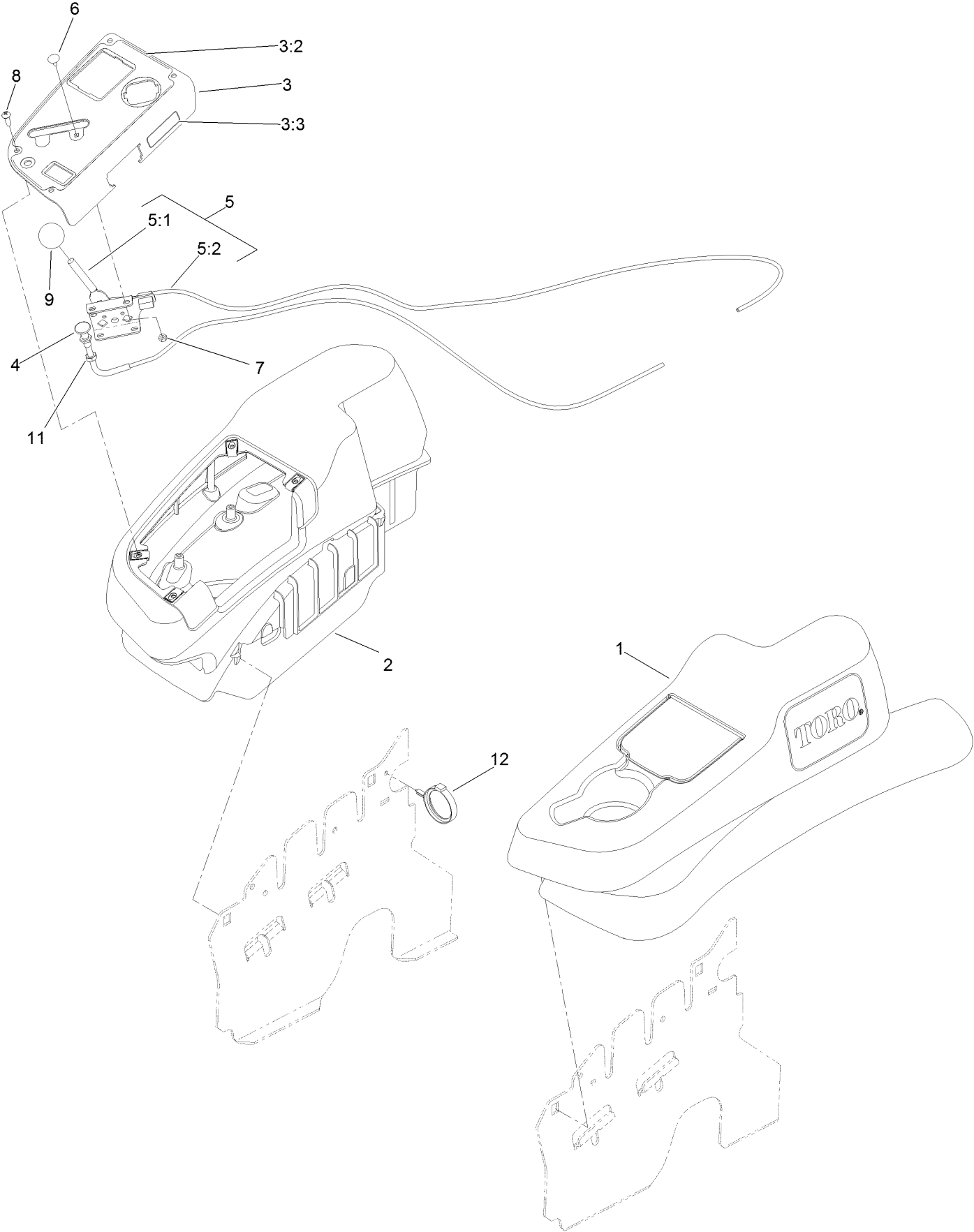

Fender, Console and Control Assembly (continued)

<i>Ref.</i>	<i>Part Number</i>	<i>Qty.</i>	<i>Description</i>	<i>Ref.</i>	<i>Part Number</i>	<i>Qty.</i>	<i>Description</i>
1	115-7403	1	LH Narrow Fender/Console ASM	5:1	112-2334	1	Lever-Throttle
2	115-7402	1	RH Narrow Fender/Console ASM	5:2	110-5728	1	Cable-Throttle
3	114-9837	1	Control Panel ASM	6	1-807513	2	Bolt-CARR
3:2	120-5898	1	Decal-Control Panel	7	3296-2	2	Nut-Lock, NI
3:3	114-4466	1	Decal-Fuses	8	32105-15	4	Screw-HWH
4	115-2753	1	Control-Choke	9	1-603175	1	Knob-Ball
5	110-5727	1	Throttle Control ASM	11	3220-3	1	Nut-HJ
				12	117-7817	1	Clamp-Harness

LH Console Assembly No. 115-7403

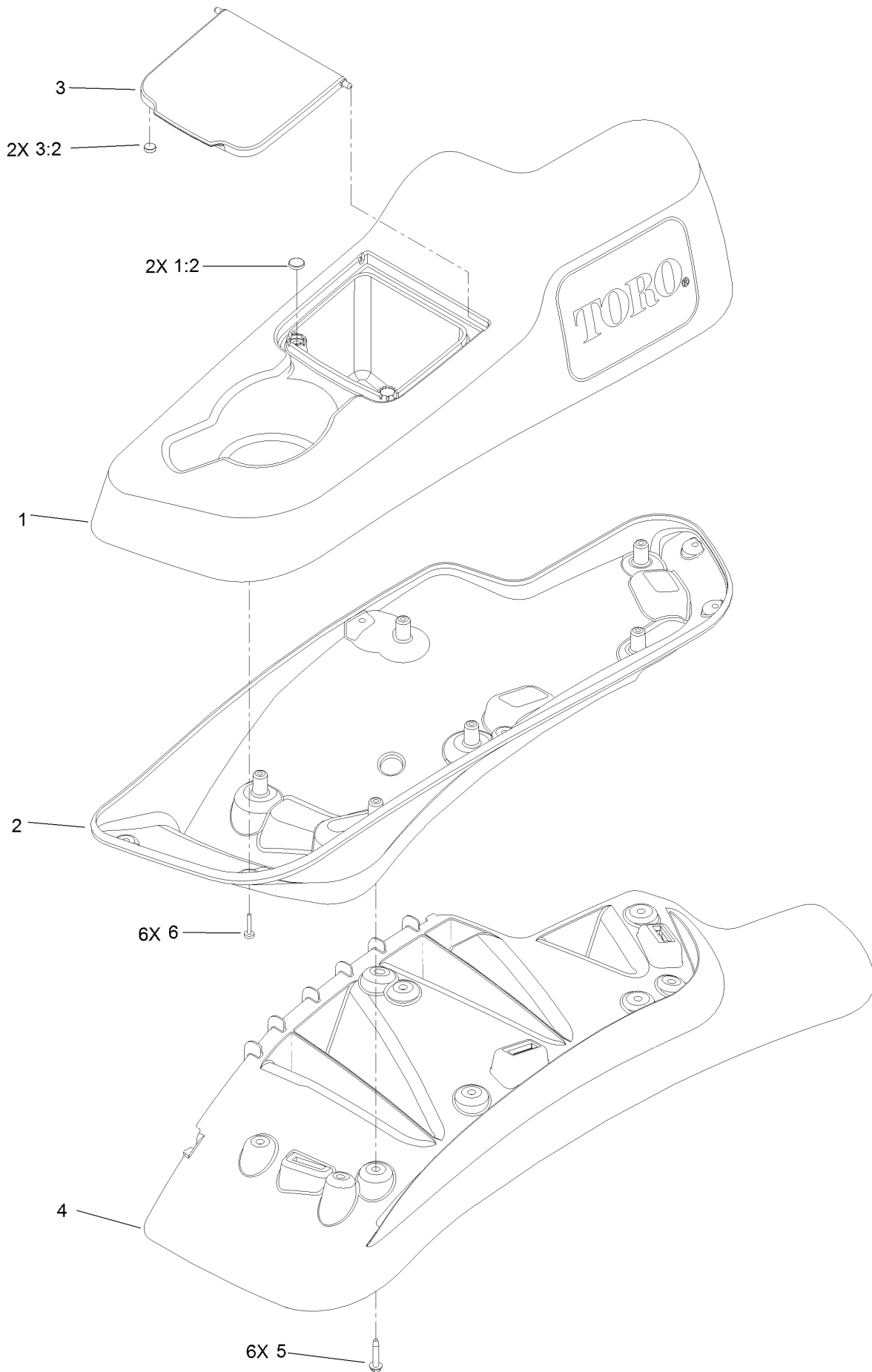

LH Console Assembly No. 115-7403 (continued)

<i>Ref.</i>	<i>Part Number</i>	<i>Qty.</i>	<i>Description</i>	<i>Ref.</i>	<i>Part Number</i>	<i>Qty.</i>	<i>Description</i>
1	114-1541	1	LH Console Top ASM	3:2	114-5896	2	Magnet
1:2	117-0883	2	Puck	4	109-9080	1	Fender-LH
2	114-9821	1	LH Lower Console ASM	5	32144-89	6	Screw-Thread Forming
3	114-1536	1	Lid ASM	6	117-0347	6	Screw-Fillister Head

RH Console Assembly No. 115-7402

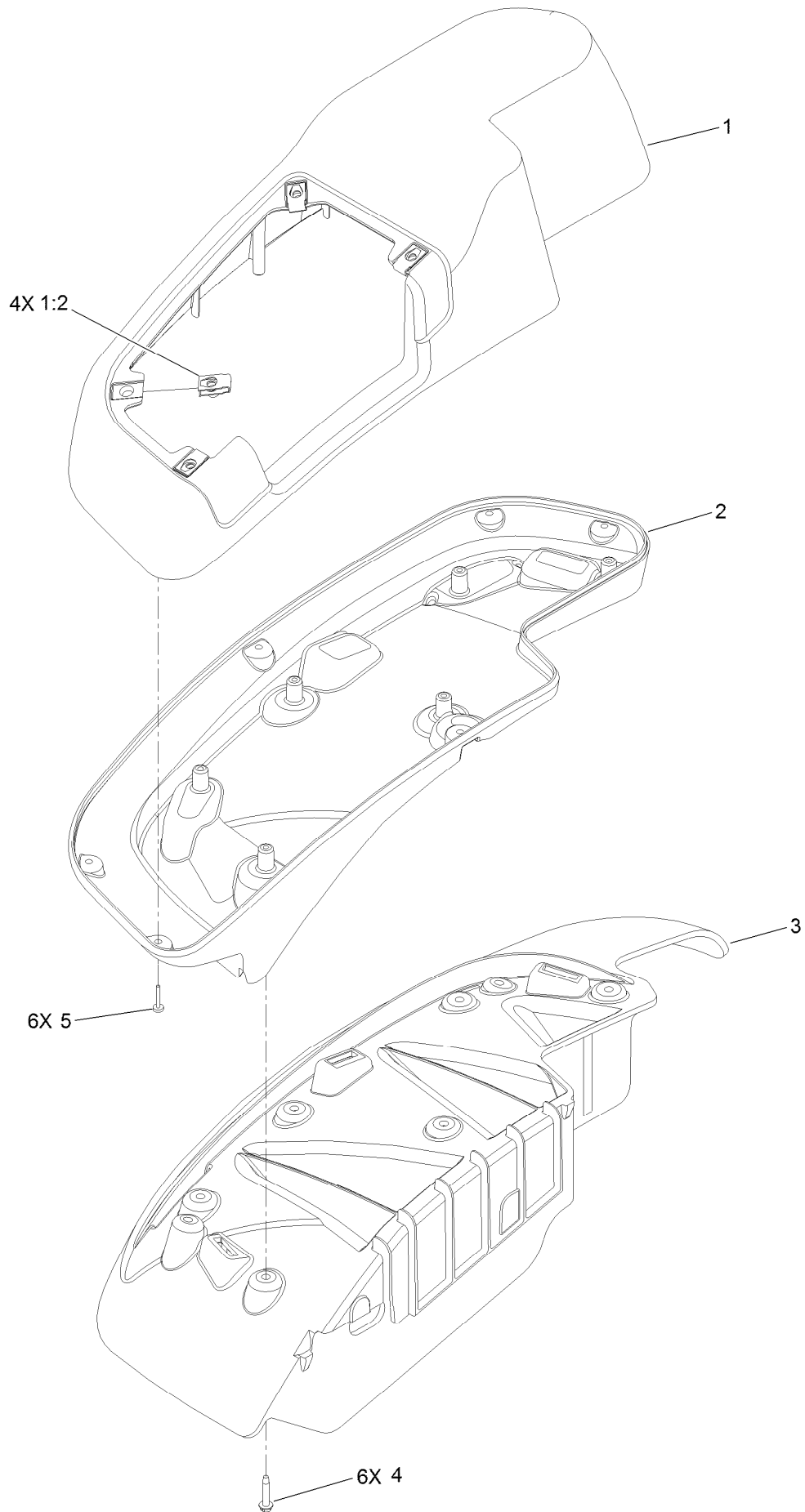

RH Console Assembly No. 115-7402 (continued)

<i>Ref.</i>	<i>Part Number</i>	<i>Qty.</i>	<i>Description</i>	<i>Ref.</i>	<i>Part Number</i>	<i>Qty.</i>	<i>Description</i>
1	114-1542	1	RH Console Top ASM	3	109-9077	1	Fender-Narrow, RH
1:2	107069	4	Clip	4	32144-89	6	Screw-Thread Forming
2	114-9823	1	Console-Narrow, RH	5	117-0347	6	Screw-Fillister Head

Electrical Assembly

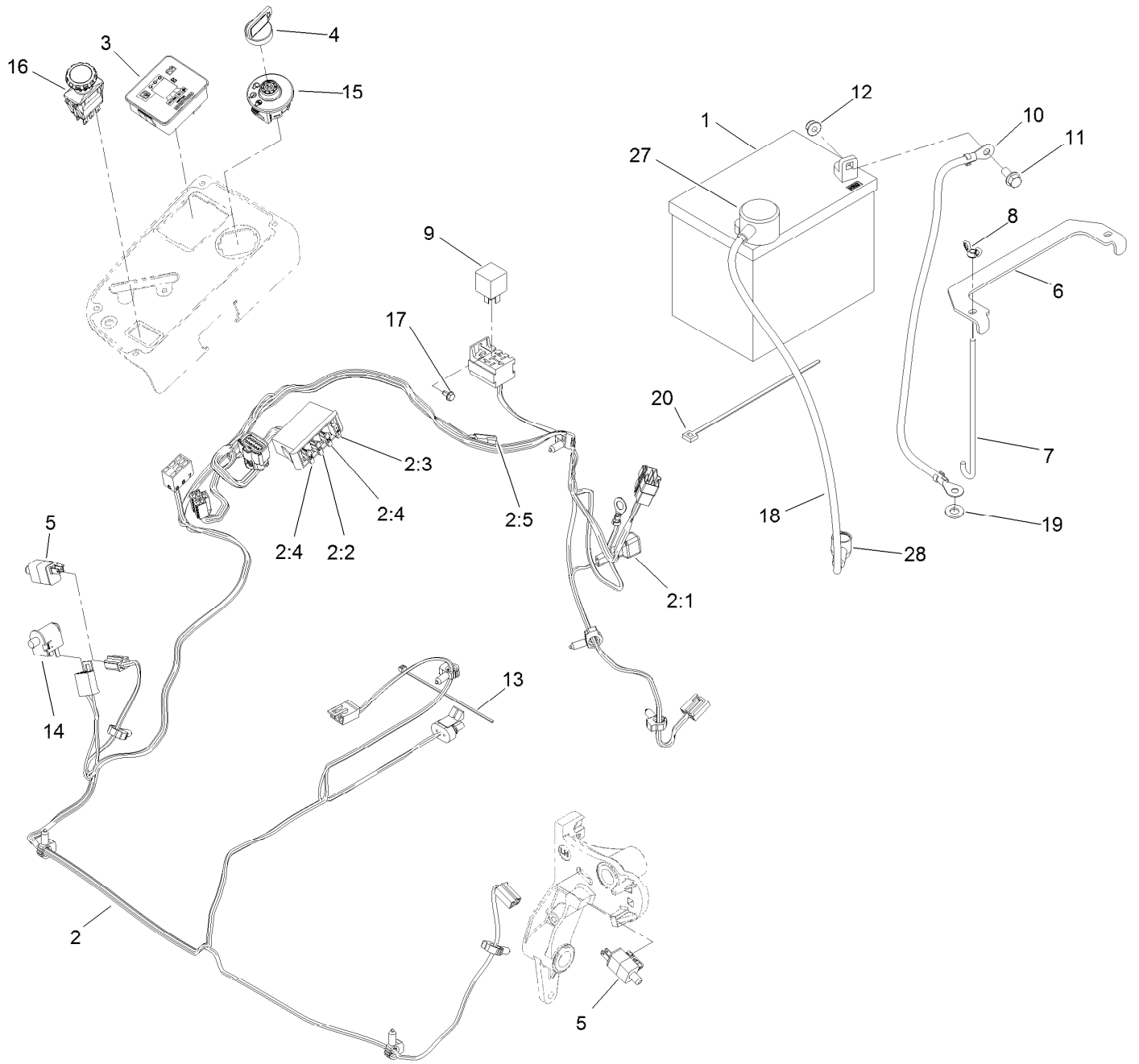

Electrical Assembly (continued)

<i>Ref.</i>	<i>Part Number</i>	<i>Qty.</i>	<i>Description</i>	<i>Ref.</i>	<i>Part Number</i>	<i>Qty.</i>	<i>Description</i>
1	104-8162	1	Battery-Dry	10	114-1218	1	Cable-Battery, Negative
2	116-6009	1	Harness-Wire, Main ●	11	3234-5	2	Screw-HHF
2:1	103-3895	1	Diode-Tvs	12	104-8300	2	Nut-Flange, NI
2:2	218-578	1	Fuse-Blade, 10 Amp	13	1-303287	3	Tie-Cable
2:3	109355	1	Fuse-Blade, 15 Amp	14	82-2190	1	Switch-Bail
2:4	109102	2	Fuse-Blade, 25 Amp	15	117-2221	1	Switch-Ignition
2:5	116-0053	1	Cap-Plug	16	116-0124	1	Switch-PTO, 10A
3	117-3882	1	Fuel/Hour Meter ASM	17	104-2065	1	Screw-HWH
4	63-8360	1	Key-Ignition	18	115-3864	1	Cable-Battery, Positive
5	110-6765	2	Switch-Single Pole No	19	3256-24	1	Washer-Flat
6	116-0042-03	1	Strap-Tie Down, Battery	20	1-303335	1	Tie-Plastic
7	1-633651	2	Bolt-Holddown	27	109-2407	1	Insulator-Battery
8	1-543792	2	Wingnut	28	1-543393	1	Insulator-Solenoid
9	1-643275	1	Relay				

● Use dielectric grease on all unsealed connectors and terminals only. Do not apply in sealed connectors.

Deck Lift Assembly

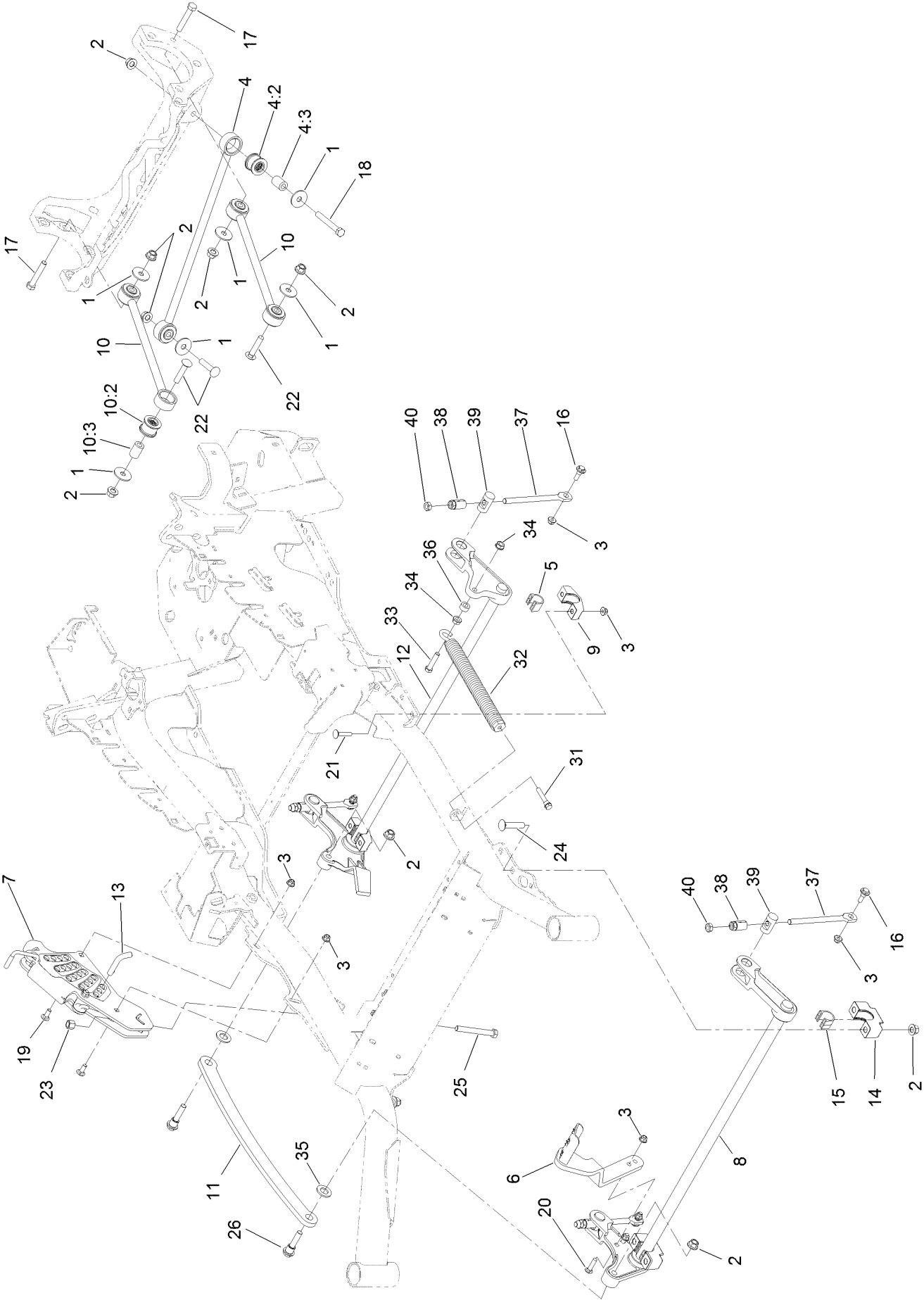

Deck Lift Assembly (continued)

<i>Ref.</i>	<i>Part Number</i>	<i>Qty.</i>	<i>Description</i>	<i>Ref.</i>	<i>Part Number</i>	<i>Qty.</i>	<i>Description</i>
1	86-1990	6	Washer-Thrust	15	109-9410	2	Bearing-Cross Shaft, Front
2	99-5107	12	Nut-Lock	16	109-9840	4	Screw-Shoulder, HHF
3	104-8301	12	Nut-Flange, NI	17	325-12	2	Screw-HH
4	109-5013	1	Panhard Rod ASM	18	325-17	1	Screw-HH
4:2	109-5009	2	Bushing-Suspension, Rubber	19	3231-2	2	Bolt-CARR
4:3	109-5010	2	Spacer	20	3231-4	2	Screw-CARR
5	109-7173	2	Bearing-Cross Shaft, Rear	21	3231-5	4	Screw-CARR
6	116-1919-01	1	Lever-Foot	22	3233-34	3	Screw-CARR
7	117-3842	1	Height-Of-Cut ASM	23	3296-23	1	Nut-Lock, NI
8	116-1771-03	1	Deck Lift-Front	24	116-1700	4	Bolt-CARR
9	116-0818-03	2	Support-Cross Shaft, Rear Bearing	25	116-0559	1	Bolt-TAP
10	109-7952	2	Deck Strut ASM	26	116-2022	2	Screw-HHF, Shoulder
10:2	109-5009	2	Bushing-Suspension, Rubber	31	92-7674	1	Bolt-Shoulder
10:3	109-5010	2	Spacer	32	116-0886	1	Extension Spring ASM
11	116-0797-03	1	Link-Lift, Deck	33	109-9065	1	Screw-HH
12	116-2645-03	1	Lift-Deck, Rear	34	32128-37	2	Nut-HF
13	116-5584	1	Pin-HOC	35	3256-28	2	Washer-Flat
14	109-9409	2	Support-Cross Shaft, Front Bearing	36	116-2695	1	Spacer
				37	109-8007	4	Link-Adjuster, Deck Lift
				38	109-7840	4	Adjuster-Lift, Deck
				39	109-8353	4	Trunnion
				40	3218-5	4	Nut-Jam

Height-of-Cut Assembly No. 117-3842

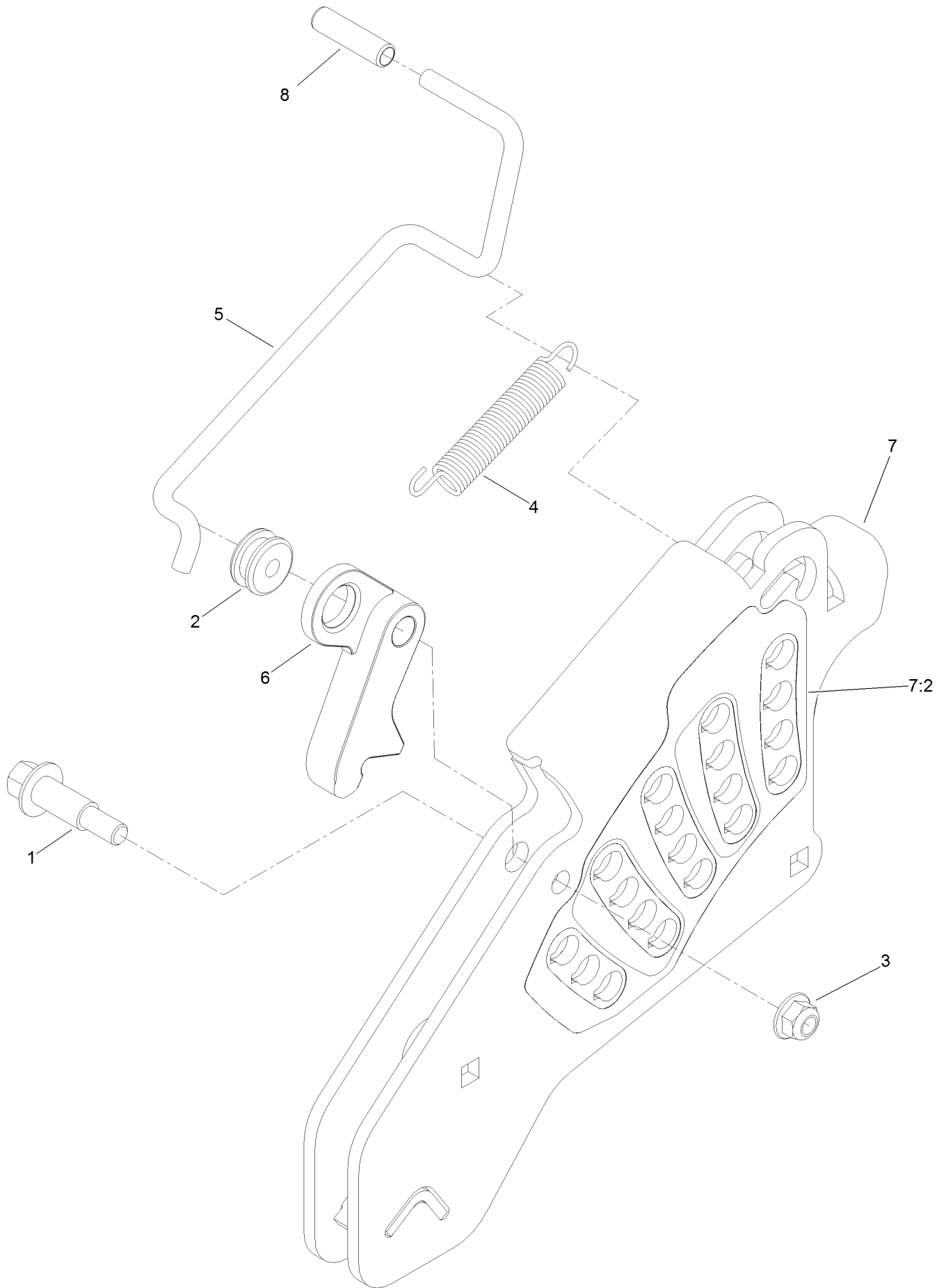

Height-of-Cut Assembly No. 117-3842 (continued)

<i>Ref.</i>	<i>Part Number</i>	<i>Qty.</i>	<i>Description</i>	<i>Ref.</i>	<i>Part Number</i>	<i>Qty.</i>	<i>Description</i>
1	62-1330	1	Bolt-Shoulder	6	116-0118	1	Pawl-Transport, HOC
2	109-7130	1	Grommet	7	117-3837	1	Plate-Height Adjuster
3	104-8301	1	Nut-Flange, NI	7:2	114-4470	1	Decal-HOC
4	109-7124	1	Spring-Extension	8	109-8250	1	Grip-Lever
5	109-7128	1	Rod-Lock, Transport				

Engine, Clutch and Muffler Assembly

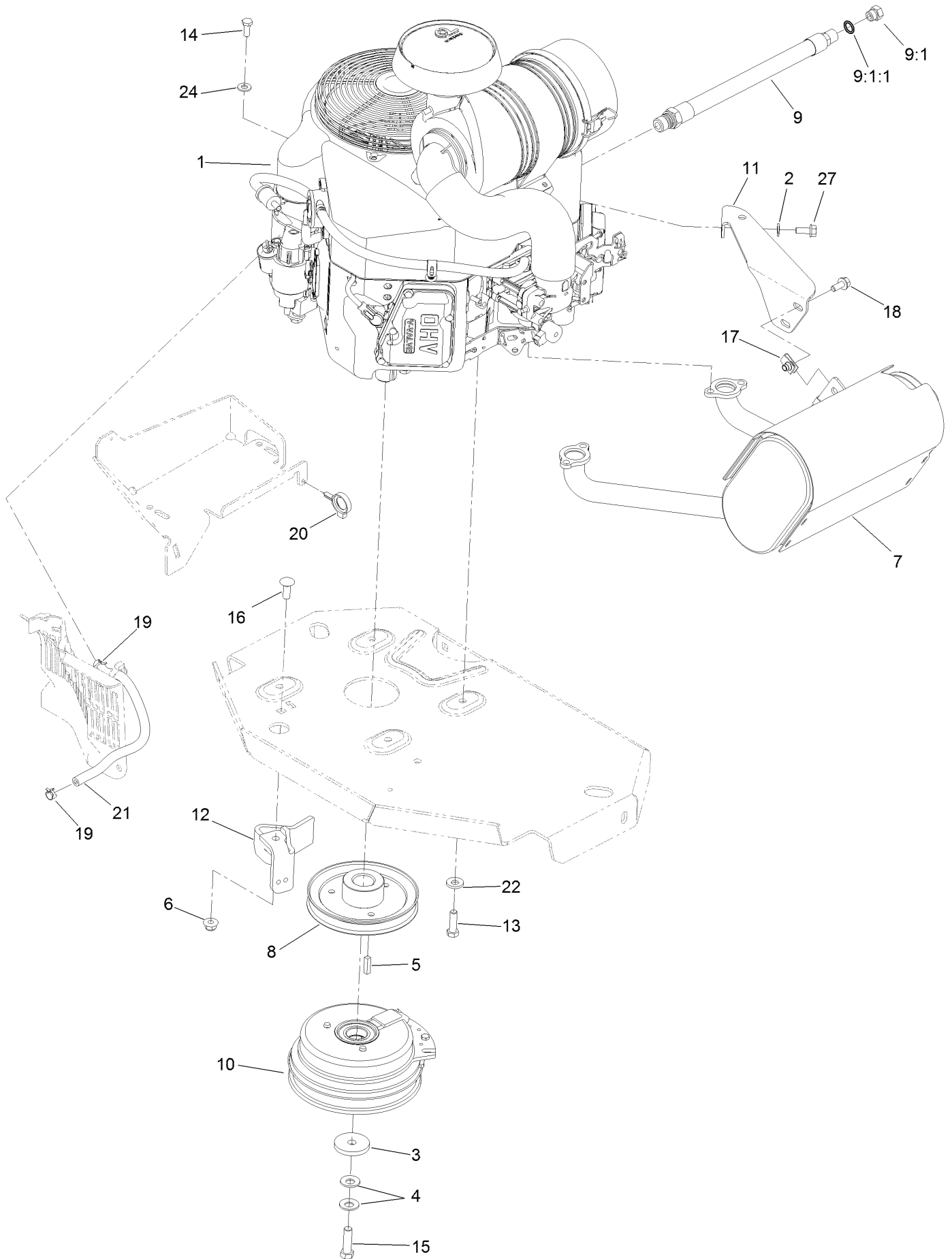

Engine, Clutch and Muffler Assembly (continued)

<i>Ref.</i>	<i>Part Number</i>	<i>Qty.</i>	<i>Description</i>	<i>Ref.</i>	<i>Part Number</i>	<i>Qty.</i>	<i>Description</i>
1		1	Engine-Kawasaki, Fx691V-S12-R ●■	11	116-1435	1	Bracket-Muffler
2	1-303334	1	Washer-Spring	12	116-2612-01	1	Clutch-Anchor
3	109-6919	1	Washer-Clutch	13	323-7	4	Screw-HH
4	1-603610	2	Washer-Spring	14	33114-020	1	Screw-HH
5	1-807259	1	Key	15	109-9761	1	Screw-HH ◆
6	104-8301	1	Nut-Flange, NI	16	3231-22	1	Screw-CARR
7	116-1715	1	Muffler	17	94-2413	2	U-Nut
8	109-9905	1	Sheave	18	3234-5	2	Screw-HHF
9	116-4924	1	Engine Oil Drain Hose ASM ▲	19	2412-98	2	Clamp-Hose
9:1	353-508	1	Plug-HH	20	105-1853	1	Clamp-Hose
9:1:1	237-42	1	O-Ring	21	109-0296	1	Hose-Fuel
10	116-1620	1	Clutch Kit	22	98-5975	4	Washer-Belleville
				24	33094-00	1	Washer-Plain
				27	95-4184	1	Screw-HHF

● Not serviced separately

▲ Use a Teflon Pipe Sealant or equivalent on threads.

◆ Use Pro-Lock, Nut Type (P/N 1-840022, .5ml tube) on threads.

■ Obtain parts from www.kawpowerepc.com

Deck Decal Assembly

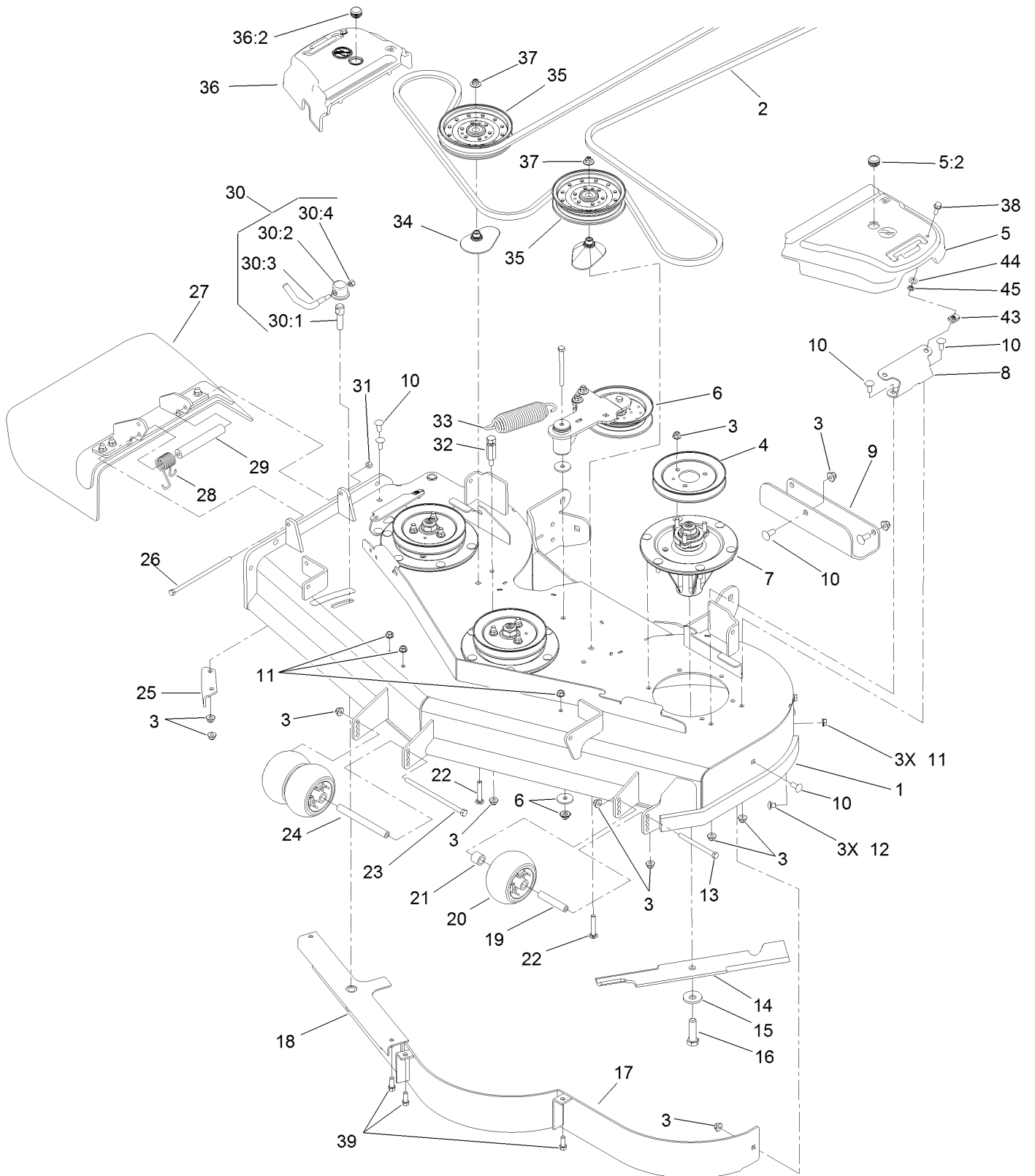

Deck Decal Assembly (continued)

<i>Ref.</i>	<i>Part Number</i>	<i>Qty.</i>	<i>Description</i>	<i>Ref.</i>	<i>Part Number</i>	<i>Qty.</i>	<i>Description</i>
1	117-3809	1	Deck Decal ASM	24	98-5967	1	Spacer-Wheel
2	115-7426	1	Belt-V	25	107-8541-01	1	Baffle-Discharge
3	104-8301	41	Nut-Flange, NI	26	322-50	1	Screw-HH
4	115-7450	3	Pulley	27	108-2792	1	Rubber Deflector ASM
5	117-7814	1	LH Belt Cover ASM	28	108-4052	1	Spring-Torsion
5:2	117-3824	1	Plug-Plastic	29	105-4622	1	Spacer
6		1	Idler Arm ASM ●	30	107-1664	1	Lever ASM
7	119-8560	3	Spindle ASM	30:1	106-3239	1	Screw-Lock
8	114-5881-01	2	Bracket-Cover, Belt	30:2	107-1644	1	Cap-Lock
9	121-7975-01	1	Plate-Skid	30:3	106-3241	1	Lever-Lock
10	3231-27	11	Screw-CARR	30:4	3296-29	1	Nut-Lock, NI
11	3290-357	6	Nut-HHF, Whiz	31	3296-29	1	Nut-Lock, NI
12	108-5387	3	Screw-CARR	32	114-5867	1	Anchor-Spring, Tall
13	323-23	1	Screw-HH	33	116-6317	1	Spring-Extension
14	105-7781-03	3	Blade-18In, Hi Flow	34	109-2872	2	Spacer-Pulley
15	103-0865	3	Washer-Blade Bolt, Heavy	35	116-4670	2	Pulley-Idler, Flat
16	51-4060	3	Screw-Blade	36	117-7813	1	RH Belt Cover ASM
17	115-7461-01	1	Baffle ASM	36:2	117-3824	1	Plug-Plastic
18	107-8506-01	1	Baffle	37	109-6658	2	Nut-Flange, NI
19	98-7912	1	Tube-Spanner	38	3234-29	2	Screw-HHF
20	1-603299	3	Roller-Scalp, Anti	39	92-1624	3	Screw-HWH
21	98-7913	1	Tube-Spacer	43	94-2413	2	U-Nut
22	3231-40	2	Bolt-CARR, Short Neck	44	73-0041	2	Washer-Thrust
23	108-5388	1	Screw-HH	45	117-2749	2	Nut-Push

● Not serviced separately

Deck Decal Assembly No. 117-3809

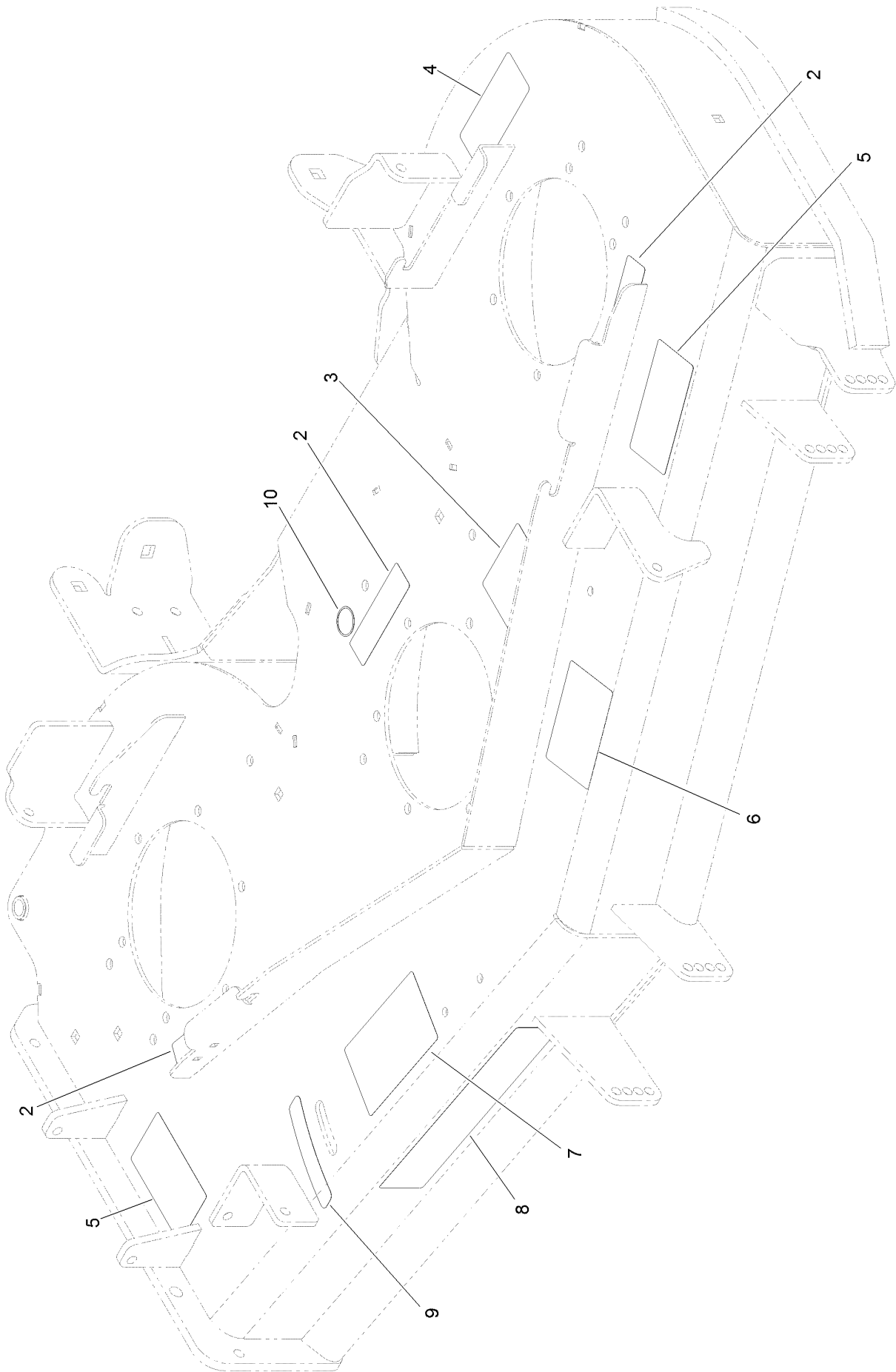

Deck Decal Assembly No. 117-3809 (continued)

<i>Ref.</i>	<i>Part Number</i>	<i>Qty.</i>	<i>Description</i>	<i>Ref.</i>	<i>Part Number</i>	<i>Qty.</i>	<i>Description</i>
2	112-9028	3	Decal-Cover Missing	7	110-2068	1	Decal-Adjustment, Baffle
3	115-7445	1	Decal-Routing, Deck Belt	8	107-1618	1	Decal
4	93-7818	1	Decal-Torque, Blade Bolt	9	110-2067	1	Decal-Setting, Baffle
5	117-3848	2	Decal-Danger	10	58-6520	1	Decal-Grease
6	99-8939	1	Decal-Anti Scalp				

Idler Assembly

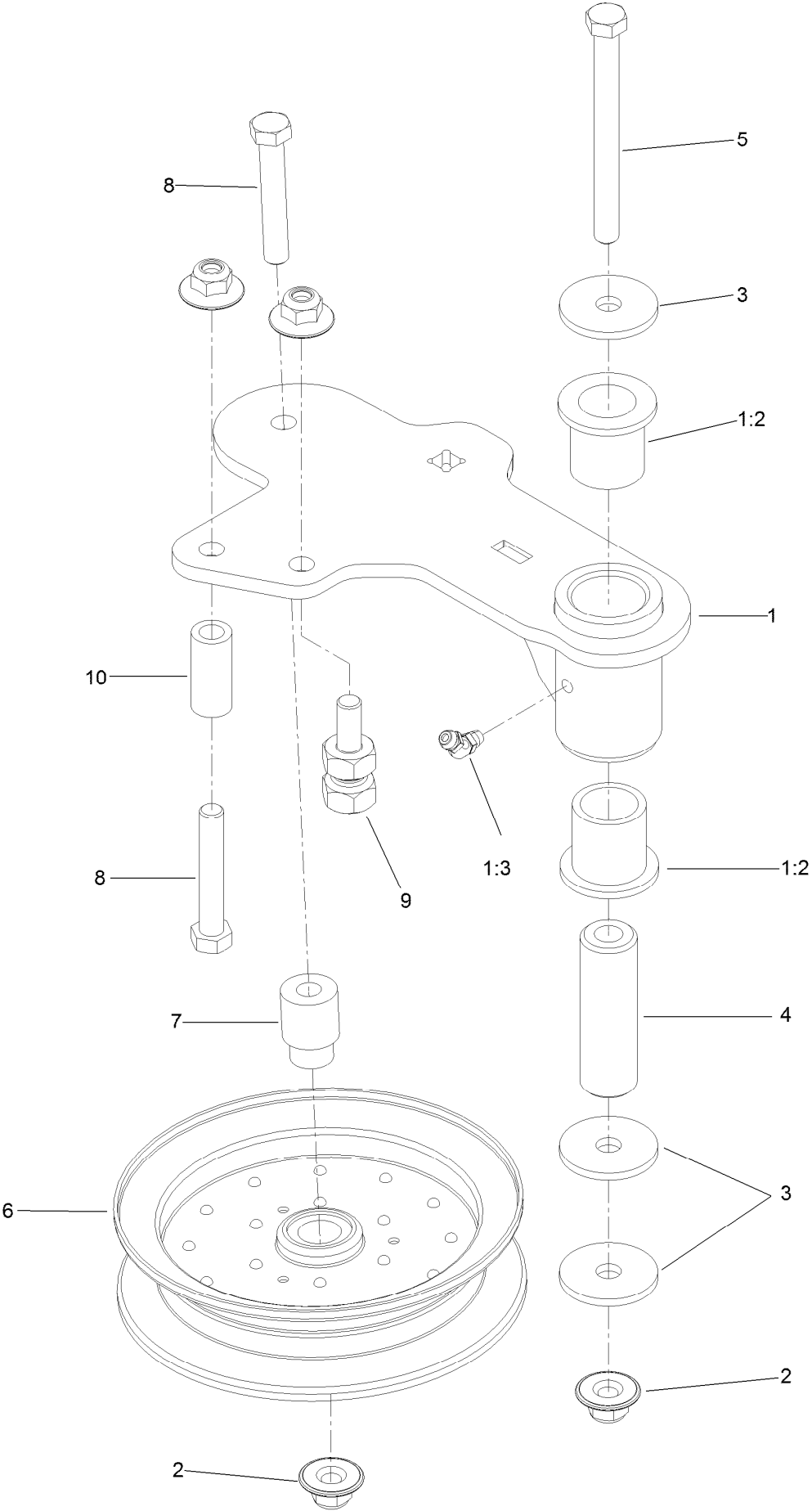

Idler Assembly (continued)

<i>Ref.</i>	<i>Part Number</i>	<i>Qty.</i>	<i>Description</i>	<i>Ref.</i>	<i>Part Number</i>	<i>Qty.</i>	<i>Description</i>
1	114-5870	1	Idler Arm ASM	5	98-5961	1	Screw-HH
1:2	1-303514	2	Bearing-Flanged	6	116-4668	1	Idler-Pulley, Flanged
1:3	1481	1	Fitting-Grease	7	112-4212	1	Mount-Pulley
2	109-6658	4	Nut-Flange, NI	8	323-11	2	Screw-HH
3	1-213069	3	Washer	9	114-5866	1	Anchor-Spring, Short
4	114-5848	1	Spacer-Plain	10	104-0151	1	Spacer

Spindle Assembly No. 119-8560

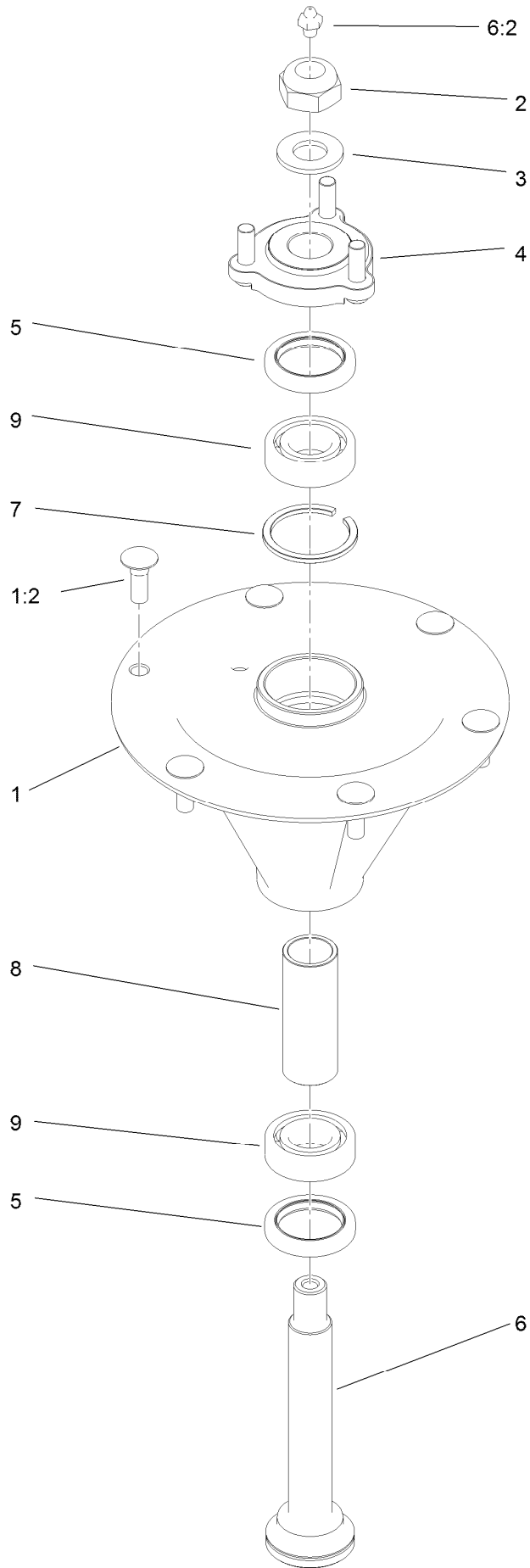

Spindle Assembly No. 119-8560 (continued)

<i>Ref.</i>	<i>Part Number</i>	<i>Qty.</i>	<i>Description</i>	<i>Ref.</i>	<i>Part Number</i>	<i>Qty.</i>	<i>Description</i>
1		1	Spindle Housing And Studs ASM ●	5	253-133	2	Seal-Oil
1:2	114-8195	6	Bolt-Ribbed Neck	6	119-8527	1	Shaft-Spindle
2	3296-67	1	Nut-Lock, NI	6:2	302-2	1	Fitting-Grease
3	92-5836	1	Washer	7	119-8532	1	Snap Ring
4	117-6172	1	Spindle Hub ASM	8	117-6184	1	Spacer
				9	119-8558	2	Bearing-Noseal

● Not serviced separately

Rubber Deflector Assembly No. 108-2792

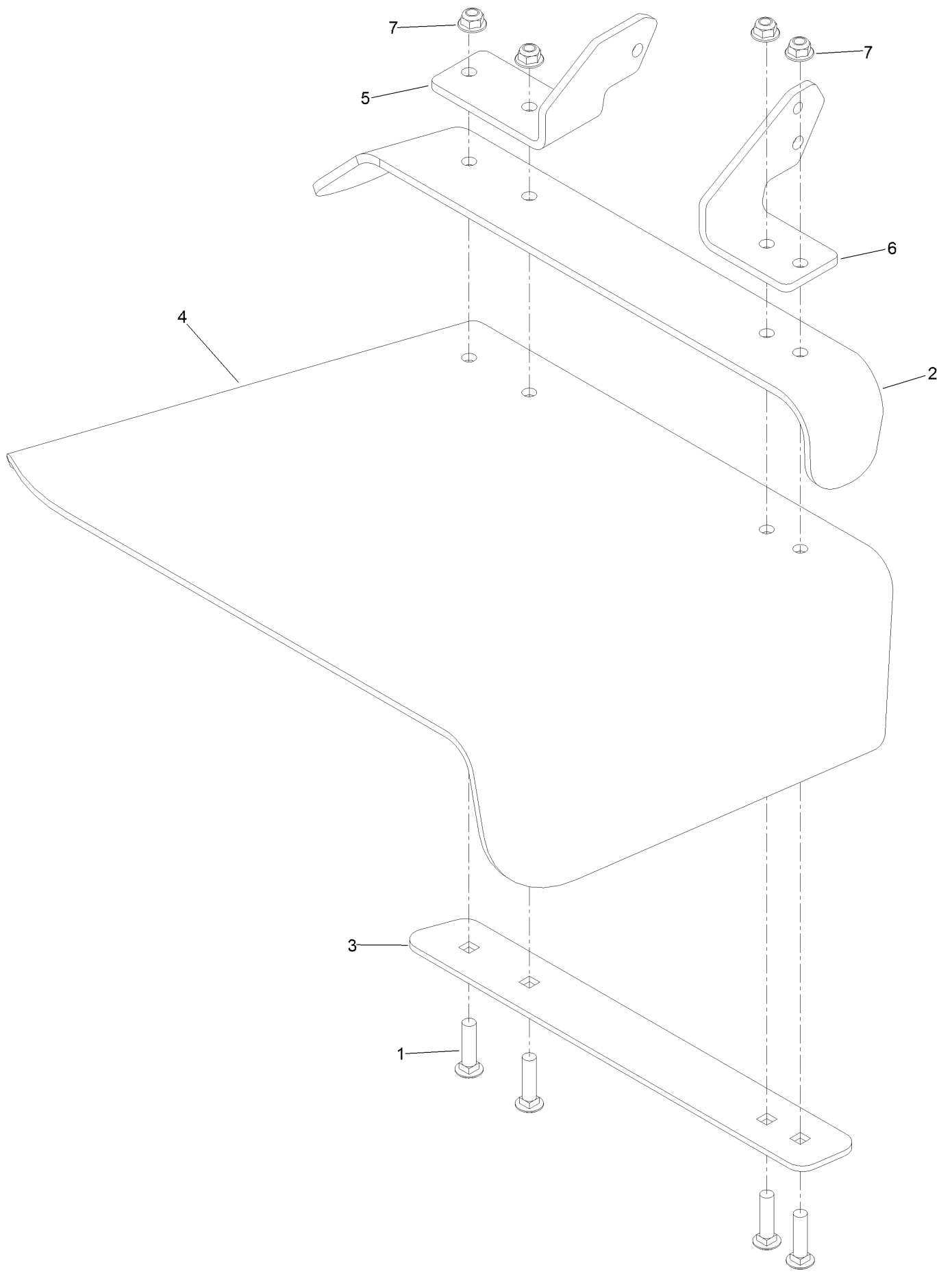

Rubber Deflector Assembly No. 108-2792 (continued)

<i>Ref.</i>	<i>Part Number</i>	<i>Qty.</i>	<i>Description</i>	<i>Ref.</i>	<i>Part Number</i>	<i>Qty.</i>	<i>Description</i>
1	3231-4	4	Screw-CARR	5	108-4059-01	1	Plate-Hinge, Rear
2	106-3246-01	1	Deflector	6	106-3253-01	1	Plate-Hinge, Front
3	106-3248-03	1	Strap-Discharge	7	104-8301	4	Nut-Flange, NI
4	108-5029	1	Deflector-Rubber				

Attachments and Accessories

For 74919TE Z Master Professional 6000 Series Riding Mower with 132cm TURBO FORCE Side Discharge Mower

Product Name	Model/Part
Blade-Recycler, 18in.....	105-7779-03
Blade-Hi Flow, 18in.....	105-7781-03
Blade-Med Flow, 18in.....	105-7794-03
Blade-Low Flow, 18in.....	105-7795-03
Blade-Atomic, 18in.....	105-7796-03
Turbo Baffle Kit.....	107-1634
Blade-Hi Flow, 18in (6 Pack).....	108-1117
Blade-Atomic, 18in (6 Pack).....	108-1118
Anti-Scalp Kit (Trim Side).....	108-4140
Hitch Kit.....	109-9487
Blade-Lo Flow, 18in (6 Pack).....	110-0406
Blade-Recycler, 18in (6 Pack).....	110-0408
Blade-Med Flow, 18in (6 Pack).....	110-0409
Hypr-Oil 500 (quart).....	114-4713
Hypr-Oil 500 (gallon).....	114-4714
Hypr-Oil 500-5 (5 gallon).....	114-4715
Bimini Folding Shade Assembly.....	115-4510
Recycler Kit.....	115-7467
Roller Striper Kit.....	115-7470
Light Kit.....	116-1154
Operator-Controlled Discharge Chute Kit.....	117-3600
CE Bagger Compliance Kit.....	117-3825
Z Stand Kit.....	121-4811
Deluxe Seat Kit.....	121-7595
Seat Tilt Frame And Iso Mount Kit.....	121-7596
Toro Deluxe Rider Cover.....	490-7319
Spark Arrestor Screen.....	75-6880
Blower and Drive Kit.....	78552
E-Z Vac Twin Bagging System.....	78562
E-Z Vac DFS Collection System.....	78566
Filter Minder Gauge.....	99-4664
Trash Holder Kit.....	TC26

Notes:



Count on it.