



Count on it.

Operator's Manual

ProCore® 648 Aerator

Model No. 09200—Serial No. 31400001 and Up

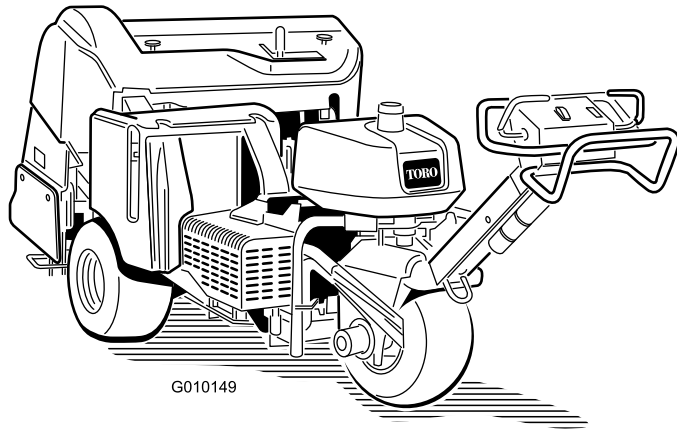

G010149

This product complies with all relevant European directives, for details please see the separate product specific Declaration of Conformity (DOC) sheet.

⚠ WARNING

**CALIFORNIA
Proposition 65 Warning**

This product contains a chemical or chemicals known to the State of California to cause cancer, birth defects, or reproductive harm.

The engine exhaust from this product contains chemicals known to the State of California to cause cancer, birth defects, or other reproductive harm.

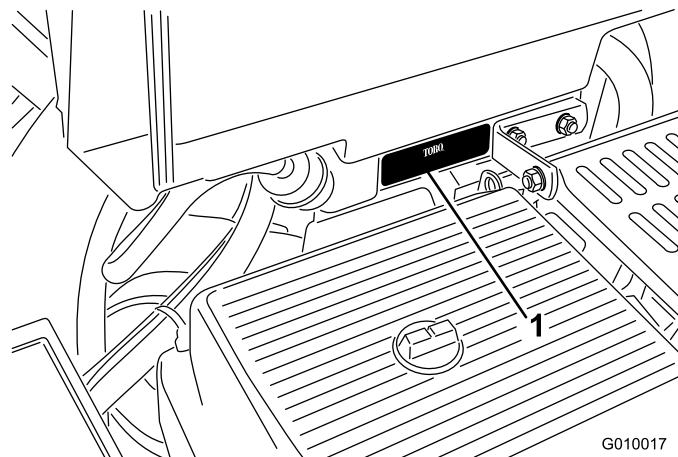

Figure 1

1. Location of the model and serial numbers

Model No. _____
Serial No. _____

Introduction

This aerator, which is controlled by a walking operator, is intended to be used by professional, hired operators in commercial applications. It is primarily designed for aerating large areas on well-maintained lawns in parks, golf courses, sports fields, and on commercial grounds.

Read this information carefully to learn how to operate and maintain your product properly and to avoid injury and product damage. You are responsible for operating the product properly and safely.

You may contact Toro directly at www.Toro.com for product and accessory information, help finding a dealer, or to register your product.

Whenever you need service, genuine Toro parts, or additional information, contact an Authorized Service Dealer or Toro Customer Service and have the model and serial numbers of your product ready. Figure 1 illustrates the location of the model and serial numbers on the product. Write the numbers in the space provided.

This manual identifies potential hazards and has safety messages identified by the safety alert symbol (Figure 2), which signals a hazard that may cause serious injury or death if you do not follow the recommended precautions.



Figure 2

1. Safety alert symbol

This manual uses 2 other words to highlight information. **Important** calls attention to special mechanical information and **Note** emphasizes general information worthy of special attention.

Contents

Introduction	2	Electrical System Maintenance	38
Safety	4	Servicing the Battery	38
Safe Operating Practices	4	Fuses	39
Sound Power Level	5	Drive System Maintenance	39
Sound Pressure Level	5	Checking the Tire Pressure	39
Vibration Level	5	Adjusting the Traction Drive for Neutral	39
Safety and Instructional Decals	6	Belt Maintenance	40
Setup	10	Adjusting the Pump Belt	40
1 Installing the Rear Wheels	10	Inspecting the Belts	41
2 Installing the Handle	11	Controls System Maintenance	41
3 Activating and Charging the Battery	11	Resetting the Ground Following System	41
4 Securing the Rear Hood (CE Only)	13	Hydraulic System Maintenance	42
5 Securing the Belt Cover (CE Only)	13	Checking the Hydraulic Lines	42
6 Installing the Tine holders, Turf Guards, and		Changing the Hydraulic Fluid and Filters	42
Tines	14	Hydraulic System Test Ports	42
Product Overview	15	Aerator Maintenance	43
Controls	15	Checking the Fastener Torque	43
Specifications	17	Adjusting the Side Shields	43
Attachments/Accessories	17	Replacing the Turf Guards	44
Operation	18	Adjusting Hole Spacing	44
Adding Fuel	18	Coring Head Timing	45
Checking the Engine Oil Level	20	Storage	45
Checking the Hydraulic Fluid	20	Troubleshooting	47
Cleaning the Engine Screen	21		
Starting and Stopping the Engine	21		
The Safety Interlock System	22		
Installing the Service Latches	22		
Installing Tine Holders, Turf Guards, and			
Tines	23		
Replacing Tines	24		
Setting the Coring Depth	24		
Setting Up Manual Ground Following	24		
Pushing/Pulling the Aerator by Hand	25		
Resetting the System Control Circuit	25		
Moving the Machine when the Coring Head is			
Stranded in the Lowered Position	26		
Transporting the Aerator	26		
Using the Line Marker	27		
Adjusting the Weight Transfer	27		
Adding Additional Weight	28		
Aerator Control Module (ACM)	28		
Operating Tips	29		
Maintenance	31		
Recommended Maintenance Schedule(s)	31		
Daily Maintenance Checklist	32		
Pre-maintenance Procedures	32		
Jacking Instructions	33		
Lubrication	34		
Checking the Coring Head Bearings	34		
Engine Maintenance	34		
Servicing the Air Cleaner	34		
Changing the Engine Oil and Filter	35		
Servicing the Spark Plugs	36		
Fuel System Maintenance	37		
Replacing the Fuel Filter	37		
Draining the Fuel Tank	37		

Safety

Improper use or maintenance by the operator or owner can result in injury. To reduce the potential for injury, comply with these safety instructions and always pay attention to the safety alert symbol, which means *Caution*, *Warning*, or *Danger*—personal safety instruction. Failure to comply with the instruction may result in personal injury or death.

Safe Operating Practices

The following instructions are adapted from the ANSI B71.4—2012 standard.

Training

- Read the *Operator's Manual* and other training material. If the operator(s) or mechanic(s) can not read English it is the owner's responsibility to explain this material to them.
- Become familiar with the safe operation of the equipment, operator controls, and safety signs.
- All operators and mechanics should be trained. The owner is responsible for training the users.
- Never let children or untrained people operate or service the equipment. Local regulations may restrict the age of the operator.
- The owner/user can prevent and is responsible for accidents or injuries occurring to himself or herself, other people or property.

Preparation

- Evaluate the terrain to determine what accessories and attachments are needed to properly and safely perform the job. Only use accessories and attachments approved by the manufacturer.
- Wear appropriate clothing including hard hat, safety glasses, and hearing protection. Long hair, loose clothing, or jewelry may get tangled in moving parts.
- Inspect the area where the equipment is to be used and remove all objects such as rocks, toys, and wire which can be contacted by the aerator.
- Check that the operator presence controls, safety switches, and shields are attached and functioning properly. Do not operate unless they are functioning properly.

Safe Handling of Fuels

- To avoid personal injury or property damage, use extreme care in handling gasoline. Gasoline is extremely flammable and the vapors are explosive.
- Extinguish all cigarettes, cigars, pipes, and other sources of ignition.
- Use only an approved fuel container.
- Never remove fuel cap or add fuel with the engine running.

- Allow engine to cool before refueling.
- Never refuel the machine indoors.
- Never store the machine or fuel container where there is an open flame, spark, or pilot light such as on a water heater or on other appliances.
- Never fill containers inside a vehicle or on a truck or trailer bed with a plastic liner. Always place containers on the ground away from your vehicle before filling.
- Remove equipment from the truck or trailer and refuel it on the ground. If this is not possible, then refuel such equipment with a portable container, rather than from a fuel dispenser nozzle.
- Keep the nozzle in contact with the rim of the fuel tank or container opening at all times until fueling is complete. Do not use a nozzle lock open device.
- If fuel is spilled on clothing, change clothing immediately.
- Never overfill fuel tank. Replace fuel cap and tighten securely.

Operation

- Never run an engine in an enclosed area.
- Only operate in good light, keeping away from holes and hidden hazards.
- Be sure all drives are in neutral and parking brake is engaged before starting engine. Start the engine only from the operator's position.
- Never operate without the shields, covers, or other guards securely in place. Be sure all interlocks are functioning properly.
- Do not change the engine governor setting or overspeed the engine.
- Stop on level ground, raise the coring head, disengage drives, engage the parking brake, and shut off the engine before leaving the operator's position for any reason.
- Stop the equipment and inspect the tines after striking an object or if an abnormal vibration occurs. Make necessary repairs before resuming operation.
- Keep hands and feet away from the tine area.
- Never carry passengers and keep pets and bystanders away.
- Be alert, slow down, and use caution when making turns. Look behind and to the side before changing directions.
- Slow down and use caution when crossing roads and sidewalks.
- Do not operate the aerator under the influence of alcohol or drugs.
- Lightning can cause severe injury or death. If lightning is seen or thunder is heard in the area, do not operate the machine; seek shelter.
- Use extreme care when loading or unloading the aerator into a trailer or truck.

- Use care when approaching blind corners, shrubs, trees, or other objects that may obscure vision.
- Always be aware of obstacles that may be in the area of operation. Plan your aeration path to avoid contact with any obstacle by you or the machine.

Slope Operation

- Do not operate near drop-offs, ditches, steep banks, or water. Wheels dropping over edges can cause rollovers, which may result in serious injury or death.
- Do not operate on slopes when grass is wet. Slippery conditions reduce traction and could cause sliding and loss of control.
- Do not make sudden turns or rapid speed changes.
- Reduce speed and use extreme caution on slopes.
- Remove or mark obstacles such as rocks, tree limbs, etc. from the operating area. Tall grass can hide obstacles.
- Watch for ditches, holes, rocks, dips, and rises that change the operating angle, as rough terrain could overturn the aerator.
- Always avoid sudden starting or stopping on a slope. If tires lose traction, disengage the tines and proceed slowly off the slope.
- Follow the recommendations for wheel weights or counterweights to improve stability.

Maintenance and Storage

- Wait for all movement to stop before adjusting, cleaning, or repairing. Disengage the tines, raise the coring head, set the parking brake, stop the engine, and remove the key.
- Clean grass and debris from the tines, drives, mufflers, and engine to help prevent fires. Clean up oil or fuel spillage.
- Let the engine cool before storing and do not store near flame.
- Shut off the fuel while storing or transporting on trailers. Do not store fuel near flames or drain indoors.
- Park the aerator on level, hard ground. Never allow untrained personnel to service it.
- Use jack stands or safety latches to support components when required.
- Carefully release pressure from components with stored energy.
- Disconnect the battery or remove the spark plug wires before making any repairs. Disconnect the negative terminal first and the positive last. Reconnect the positive first and the negative last.
- Keep hands and feet away from moving parts. If possible, do not make adjustments with the engine running.
- Charge batteries in an open well ventilated area, away from spark and flames. Unplug the charger before

connecting or disconnecting it from the battery. Wear protective clothing and use insulated tools.

- Keep all parts in good working condition and all hardware tightened. Replace all worn or damaged decals.
- Use only Toro-approved attachments. The warranty may be voided if the machine is used with unapproved attachments.

Hauling

- Use care when loading or unloading the machine into a trailer or truck.
- Use full width ramps for loading machine into trailer or truck.
- Tie the machine down securely using straps, chains, cable, or ropes. Both front and rear straps should be directed down and outward from the machine

Sound Power Level

This unit has a guaranteed sound power level of 101 dBA, which includes an Uncertainty Value (K) of 1 dBA.

Sound power level was determined according to the procedures outlined in ISO 11094.

Sound Pressure Level

This unit has a sound pressure level at the operator's ear of 84 dBA, which includes an Uncertainty Value (K) of 1 dBA.

Sound pressure level was determined according to the procedures outlined in EN ISO 11201.

Vibration Level

Hand-Arm

Measured vibration level for right hand = 6.15 m/s²

Measured vibration level for left hand = 6.57 m/s²

Uncertainty Value (K) = 0.4 m/s²

Measured values were determined according to the procedures outlined in EN 1032.

Safety and Instructional Decals



Safety decals and instructions are easily visible to the operator and are located near any area of potential danger. Replace any decal that is damaged or lost.

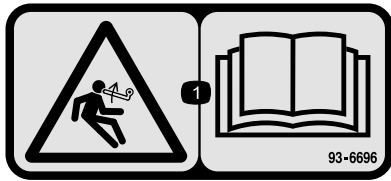

93-6696

1. Stored energy hazard—read the *Operator's Manual*.

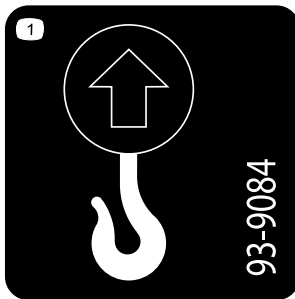

93-9084

1. Lift point
2. Tie-down point

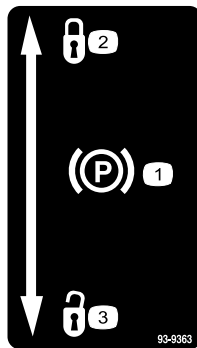

93-9363

1. Parking brake
2. Locked
3. Unlocked

CALIFORNIA SPARK ARRESTER WARNING
 Operation of this equipment may create sparks that can start fires around dry vegetation. A spark arrester may be required. The operator should contact local fire agencies for laws or regulations relating to fire prevention requirements. 117-2718

117-2718

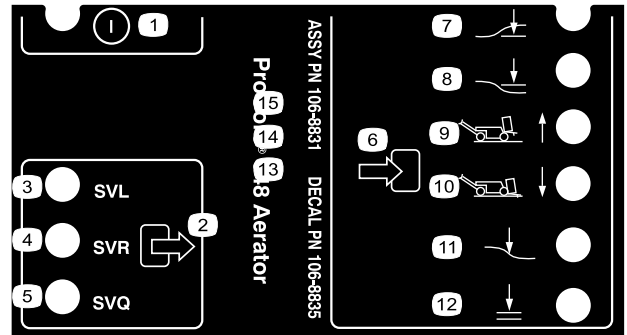

106-8835

- | | |
|-------------------------|----------------------|
| 1. On/off | 7. Head low |
| 2. Output | 8. Head high |
| 3. Solenoid valve lower | 9. Transport (1) |
| 4. Solenoid valve raise | 10. Aerate (4) |
| 5. Solenoid valve quick | 11. Ground following |
| 6. Input | 12. OK to lower |

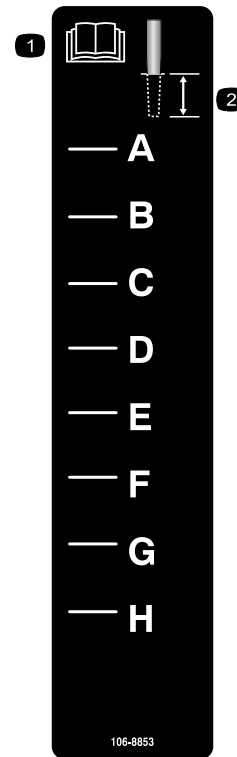

106-8853

1. Read the *Operator's Manual*.
2. Coring depth

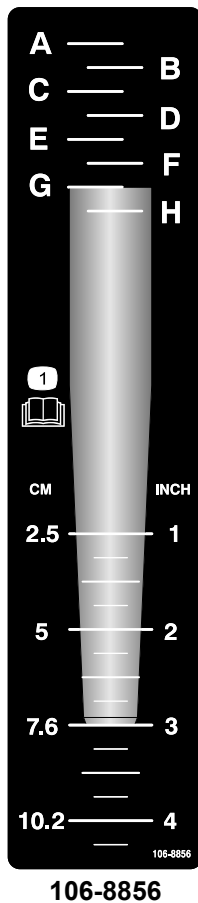

106-8856

1. Read the *Operator's Manual*.

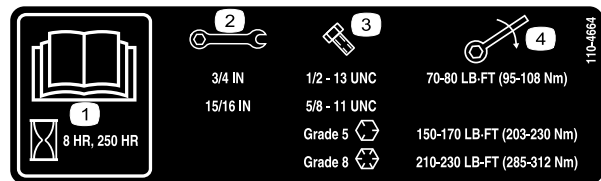

110-4664

1. Read the *Operator's Manual*.
2. Wrench size
3. Bolt size
4. Torque

Battery Symbols

Some or all of these symbols are on your battery

1. Explosion hazard
2. No fire, open flame, or smoking.
3. Caustic liquid/chemical burn hazard
4. Wear eye protection
5. Read the *Operator's Manual*.
6. Keep bystanders a safe distance from the battery.
7. Wear eye protection; explosive gases can cause blindness and other injuries
8. Battery acid can cause blindness or severe burns.
9. Flush eyes immediately with water and get medical help fast.
10. Contains lead; do not discard.

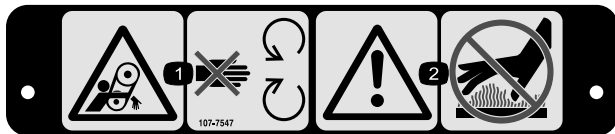

107-7547

1. Entanglement hazard, belt—stay away from moving parts.
2. Warning—Do not touch the hot surfaces



107-7555

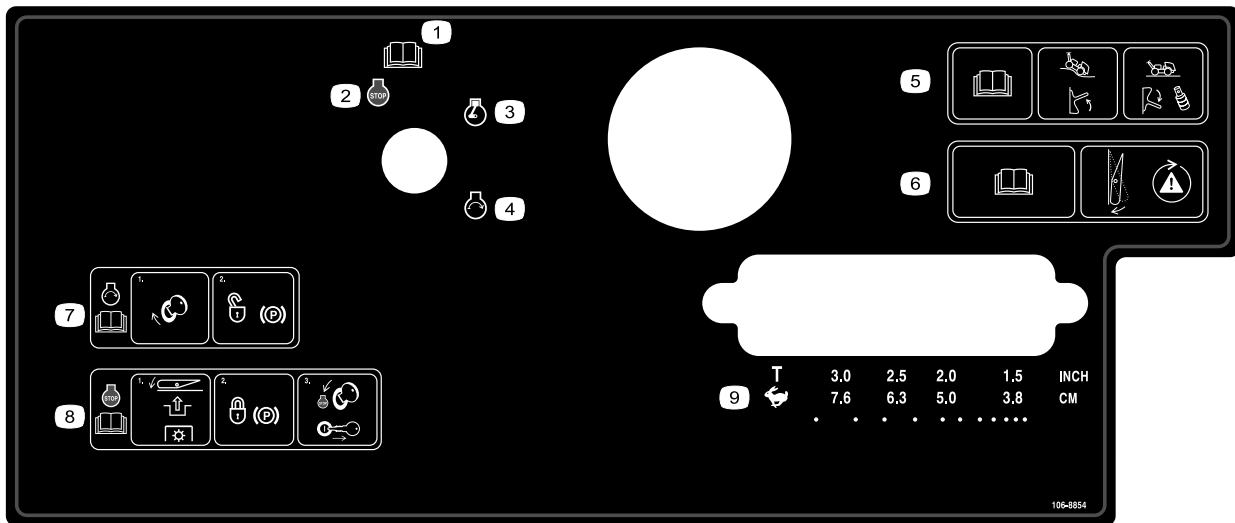

106-8854

1. Read the *Operator's Manual*.
2. Engine—stop
3. Engine—run
4. Engine—start
5. Read the *Operator's Manual*; move the switch up to turn ground following on; move the switch down and install the spacers to turn ground following off.
6. Read the *Operator's Manual*; press the switch to test the safety system.
7. To start the engine, turn the ignition key and unlock the parking brake; read the *Operator's Manual*.
8. To stop the engine, press the switch to disengage the PTO, lock the parking brake, and turn the ignition key to the Stop position and remove it; read the *Operator's Manual*.
9. Transport or hole spacing selection

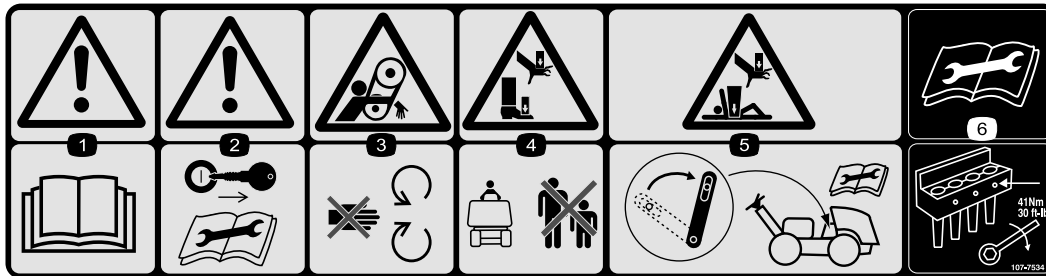

107-7534

1. Warning—read the *Operator's Manual*.
2. Warning—remove the ignition key and read the instructions before servicing or performing maintenance.
3. Entanglement hazard, belt—stay away from moving parts.
4. Crushing hazard of hand or foot—keep bystanders a safe distance from the machine.
5. Crushing hazard of hand and body—engage the service latch when the coring head is raised; read the instructions before servicing or performing maintenance.
6. Read the instructions before servicing or performing maintenance—torque the tine bolts to 41 N-m (30 ft-lb).

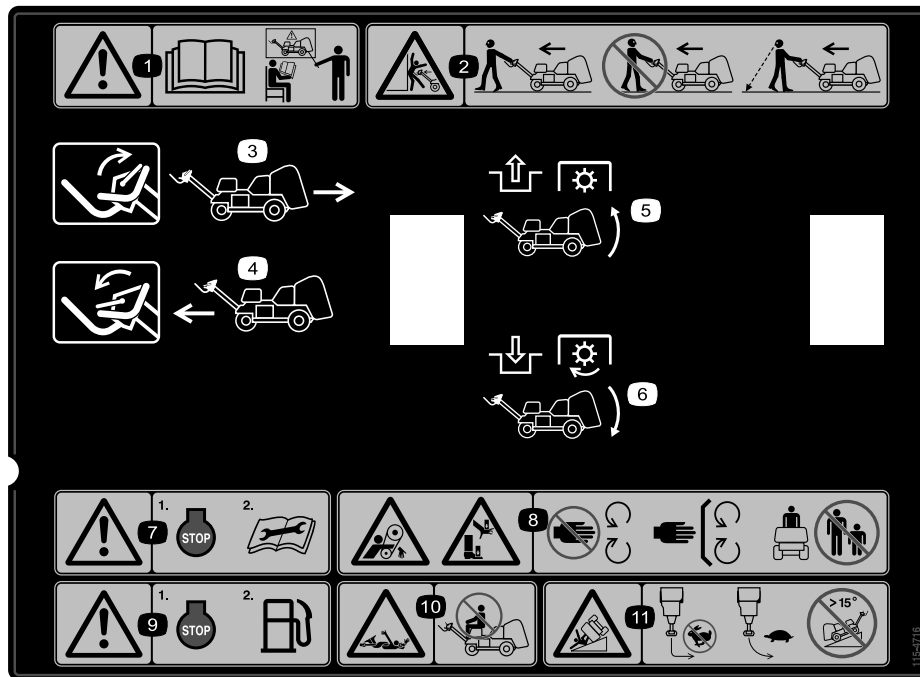

115-4716

1. Warning—do not operate this machine unless you are trained.
2. Crushing hazard—Walk in a forward direction while operating the machine, do not walk and face backwards when operating the machine, always look down and behind you when walking backwards while operating the machine.
3. Move the lever up to drive in reverse.
4. Move the lever down to drive forward.
5. Disengage the PTO and raise the head.
6. Engage the PTO and lower the head.
7. Warning—stop the engine and read the instructions before servicing or performing maintenance.
8. Entanglement hazard, belt; crushing hazard of hand or foot—stay away from moving parts, keep all guards and shields in place; keep bystanders a safe distance from the machine.
9. Warning—stop the engine before fueling.
10. Entanglement hazard, shaft—do not carry passengers.
11. Tipping hazard—do not turn sharply while traveling fast, drive slowly when turning, and do not drive the machine on a slope greater than 15 degrees.

Setup

Loose Parts

Use the chart below to verify that all parts have been shipped.

Procedure	Description	Qty.	Use
1	Wheel assembly	2	Install the rear wheels.
2	Locknut (1/2 inch)	3	Install the handle.
	Cable guide	1	
	Bolt (5/16 x 1/2 inch)	2	
3	Bolt (1/4 x 1 inch)	2	Activate and charge the battery.
	Flange nut (5/16 inch)	2	
4	Latch lock	2	Securing the rear hood (CE only).
	Tap bolt	2	
	Internal tooth lock washer	2	
5	Lanyard	1	Secure the belt cover (CE only).
	Pop rivet	1	
	Bolt (1/4 x 1 inch)	1	
	Locknut (1/4 inch)	1	
6	No parts required	–	Install the tine holders, turf guards, and tines.

Media and Additional Parts

Description	Qty.	Use
Ignition key	2	Start the machine
Turf guard clamp	4	Install the turf guards.
Flange nut	12	
Operator's Manual	1	Read before operating the machine.
Engine Operator's Manual	1	
Operator training material	1	View before operating the machine.
Parts Catalog	1	View and order parts.
Declaration of conformity	1	CE certification
Pre-delivery checklist	1	Ensure that all setup procedures have been completed before delivery.

Note: Determine the left and right sides of the machine from the normal operating position.

Note: To raise the coring head after uncrating the machine, start the engine and press the Reset button. Refer to the Operation section of this manual for more information.

1

Installing the Rear Wheels

Parts needed for this procedure:

2	Wheel assembly
---	----------------

Procedure

1. Remove the 8 lug nuts securing the rear of the aerator to the packaging.
2. Mount a wheel assembly onto each rear wheel hub (Figure 3).

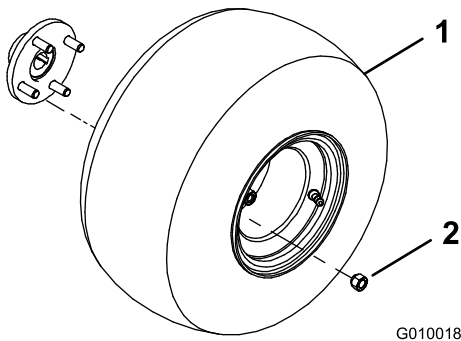

Figure 3

1. Wheel assembly
2. Lug nut

3. Install the lug nuts (Figure 3) and tighten them to 61 to 75 N-m (45 to 55 ft-lb).
4. Deflate all tires to 83 kPa (12 psi).

2

Installing the Handle

Parts needed for this procedure:

3	Locknut (1/2 inch)
1	Cable guide
2	Bolt (5/16 x 1/2 inch)

Procedure

1. Carefully rotate the handle to the front of the machine. Use caution not to damage the cables.
2. Insert the handle mounting studs into the holes in the fork (Figure 4).

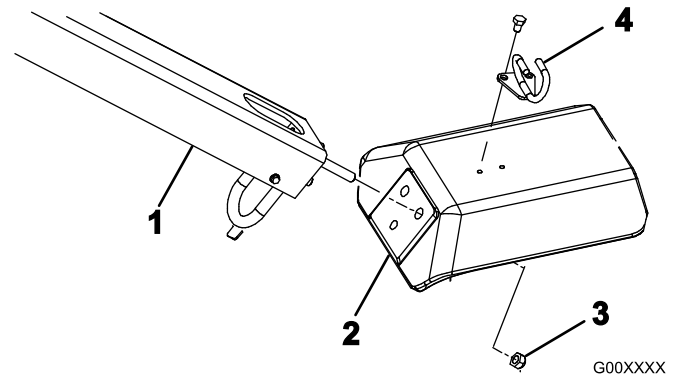

Figure 4

1. Handle
 2. Fork
 3. Locknut
 4. Cable guide
-
3. Secure handle studs to fork with 3 locknuts (1/2 inch) (Figure 4)
 4. Insert the cable guide around the cables.
 5. Mount the cable guide to the top of the fork with 2 bolts (5/16 x 1/2 inch) (Figure 4).

3

Activating and Charging the Battery

Parts needed for this procedure:

2	Bolt (1/4 x 1 inch)
2	Flange nut (5/16 inch)

Procedure

WARNING

CALIFORNIA
Proposition 65 Warning

Battery posts, terminals, and related accessories contain lead and lead compounds, chemicals known to the State of California to cause cancer and reproductive harm.

Wash hands after handling.

1. Unlatch and open the battery compartment cover.
2. Remove the battery from the battery compartment (Figure 5).

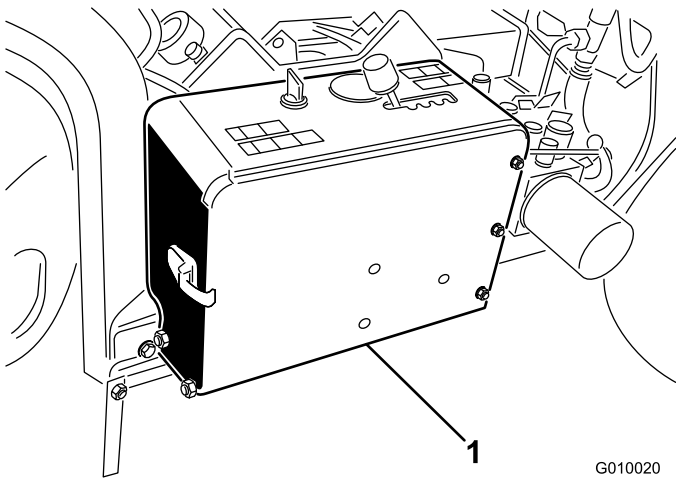

Figure 5

G010020

1. Battery compartment

3. Clean the top of the battery and remove the vent caps.
4. Carefully fill each cell with electrolyte until the plates are covered with about 6 mm (1/4 inch) of fluid.

Use only electrolyte (1.265 Specific Gravity) to fill the battery initially.

Important: Do not add electrolyte while the battery is in the machine. You could spill it, causing corrosion.

⚠ DANGER

Battery electrolyte contains sulfuric acid which is a deadly poison and causes severe burns.

- Do not drink electrolyte and avoid contact with skin, eyes, or clothing. Wear safety glasses to shield your eyes and rubber gloves to protect your hands.
 - Fill the battery where clean water is always available for flushing the skin.
5. Allow approximately 20 to 30 minutes to allow all trapped gas to escape from the plates. Refill as necessary to bring the electrolyte to within about 6 mm (1/4 inch) of the bottom of the fill well.
 6. Connect a 3 to 4 amp battery charger to the battery posts. Charge the battery at a rate of 3 to 4 amps until the specific gravity is 1.250 or higher and the temperature is at least 16 degrees C (60 degrees F) with all cells gassing freely.

⚠ WARNING

Charging the battery produces gasses that can explode.

Never smoke near the battery and keep sparks and flames away from it.

7. When the battery is charged, disconnect the charger from the electrical outlet and battery posts.

Note: After the battery has been activated, add only distilled water to replace normal loss, although maintenance-free batteries should not require water under normal operating conditions.

8. Insert the battery into the tray in the battery compartment (Figure 6) Position the battery so the terminals are to the outside.

⚠ WARNING

Battery terminals or metal tools could short against metal machine components causing sparks. Sparks can cause the battery gasses to explode, resulting in personal injury.

- When removing or installing the battery, do not allow the battery terminals to touch any metal parts of the machine.
- Do not allow metal tools to short between the battery terminals and metal parts of the machine.

9. Secure the battery to the compartment base with a battery rod, 2 hold down rods, 2 flat washers, and 2 wing nuts (Figure 6).

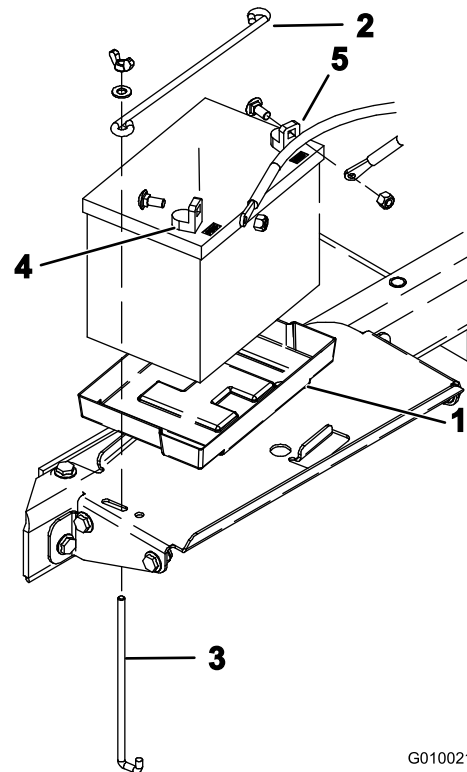

Figure 6

G010021

1. Battery tray
2. Battery hold down
3. Hold down rod
4. Positive terminal (+)
5. Negative terminal (-)

- First, secure the positive cable (red) to the positive (+) battery terminal with a carriage bolt and nut (Figure 6), then the negative cable (black) to the negative (-) terminal of the battery with a carriage bolt and nut (Figure 6). Slide the rubber boot over the positive terminal to prevent a possible short from occurring.

Important: Make sure there is clearance between the battery cables and the speed selector lever. Verify that the speed selector lever does not come within 1 inch (2.5 cm) of either battery cable when it is moved through its entire range of motion. Do not wire tie or tape the negative and positive battery cables together.

⚠ WARNING

Incorrect battery cable routing could damage the machine and cables causing sparks. Sparks can cause the battery gasses to explode, resulting in personal injury.

- Always *disconnect* the negative (black) battery cable before disconnecting the positive (red) cable.
- Always *connect* the positive (red) battery cable before connecting the negative (black) cable.

- Close and latch the battery compartment cover.

4

Securing the Rear Hood (CE Only)

Parts needed for this procedure:

2	Latch lock
2	Tap bolt
2	Internal tooth lock washer

Procedure

If you are setting up this machine for use in the European Union (CE), secure the rear hood as follows to comply with CE regulations.

- Install a latch lock over the left and right side hood latches with a tap bolt (two total) (Figure 7).

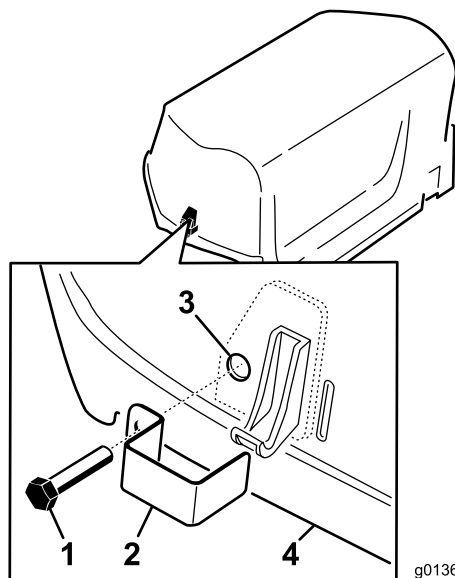

Figure 7

g013611

- Tap bolt
- Latch lock
- Internal lock washer (inside of hood)
- Hood

- Using a pliers or adjustable wrench, thread an internal lock washer onto each bolt (1-2 threads) to secure bolt (Figure 7).

5

Securing the Belt Cover (CE Only)

Parts needed for this procedure:

1	Lanyard
1	Pop rivet
1	Bolt (1/4 x 1 inch)
1	Locknut (1/4 inch)

Procedure

If you are setting up this machine for use in the European Union (CE), secure the belt cover as follows to comply with CE regulations.

- Locate the hole in the belt cover next to the latch lever (Figure 8 and Figure 9).

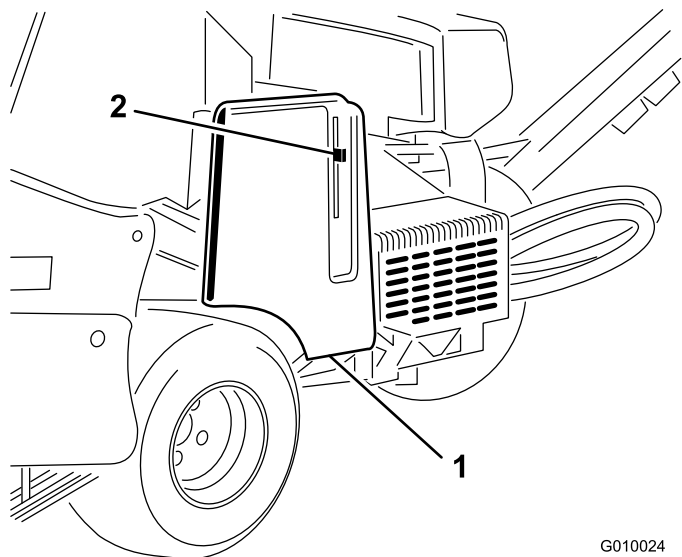

Figure 8

G010024

1. Belt cover
2. Latch lever

2. Using the hole in the belt cover, install the lanyard assembly with a pop rivet (Figure 9).

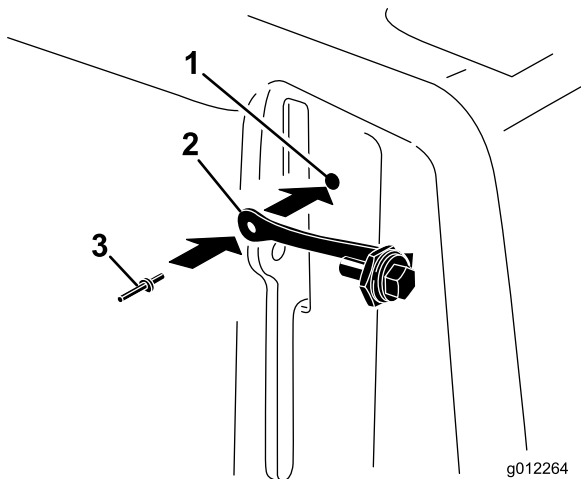

Figure 9

g012264

1. Belt cover hole
2. Lanyard
3. Pop rivet

3. Thread the bolt into the belt cover latch lever (Figure 10).

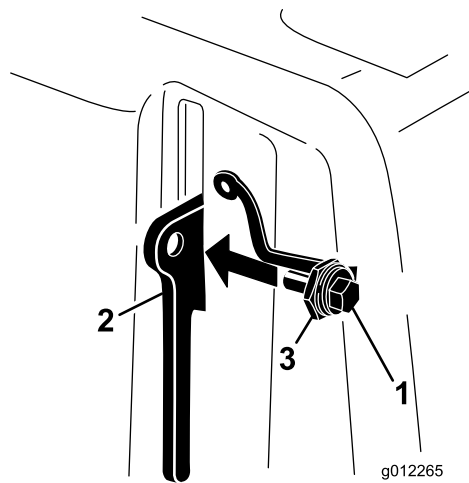

Figure 10

g012265

1. Bolt
2. Latch lever
3. Nut

6

Installing the Tine holders, Turf Guards, and Tines

No Parts Required

Procedure

A wide selection of tine holders, turf guards, and tines are available for the aerator. Install the setup appropriate for your application as described in *Installing the Tine holders, Turf Guards, and Tines in Operation*.

Product Overview

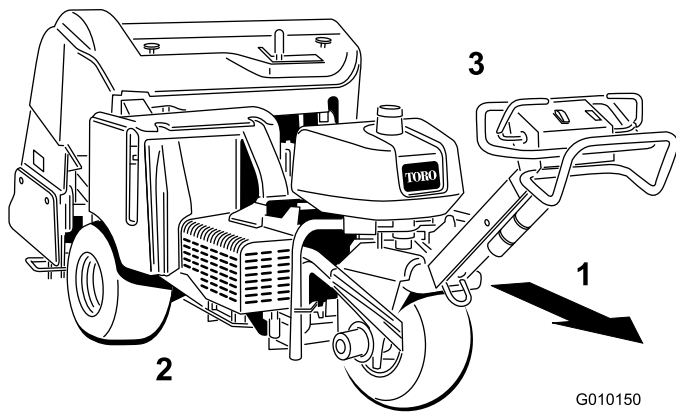

Figure 11

- | | |
|------------------------|--------------|
| 1. Operating direction | 3. Left side |
| 2. Right side | |

Controls

Become familiar with all the controls before you start the engine and operate the aerator.

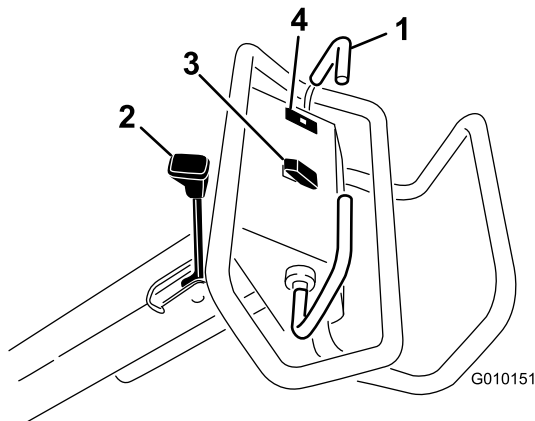

Figure 12

- | | |
|-------------------|-------------------------------|
| 1. Traction lever | 3. Raise, lower/engage switch |
| 2. Parking brake | 4. Oil pressure warning light |

Traction Lever

To move forward, move the traction lever forward. To move rearward, move the traction lever rearward (Figure 12).

The farther you move the traction lever, the faster the aerator will move.

To stop, release the traction lever.

Parking Brake

To engage the parking brake, move the lever toward the engine. To disengage the parking brake, move the lever forward (Figure 12).

Always set the parking brake when you stop the aerator or leave it unattended.

Jog the traction lever forward and reverse to release the parking brake.

Oil Pressure Warning Light

The oil pressure warning light (Figure 12) glows when the oil pressure in the engine drops below a safe level. If low oil pressure ever occurs, stop the engine and determine the cause. Repair the damage before starting the engine again.

Raise, Lower/Engage Switch

Raise—Press the top of the switch (Figure 12) to raise the coring head and disengage the coring head. The engine must be running to generate lift pressure. If the coring head is below the transport height, refer to System Control Circuit Reset.

Lower/Engage—Press the bottom of the switch (Figure 12) to lower and engage the coring head. The traction lever must be in the forward position to activate the switch.

⚠ CAUTION

Keep hands and feet away from the coring head. Make sure the coring head area is clear of any obstructions before lowering it.

To lower the coring head without engaging it, turn the ignition key to the Run position (without the engine running), move the traction lever to the forward position, and press the bottom of the switch.

Ignition Switch

The ignition switch (Figure 13), which is used to start and stop the engine, has three positions: Off, Run, and Start. Rotate key clockwise to the Start position to engage starter motor. When engine starts, release key and it will move automatically to the On position. To shut the engine off, rotate the key counterclockwise to the Off position.

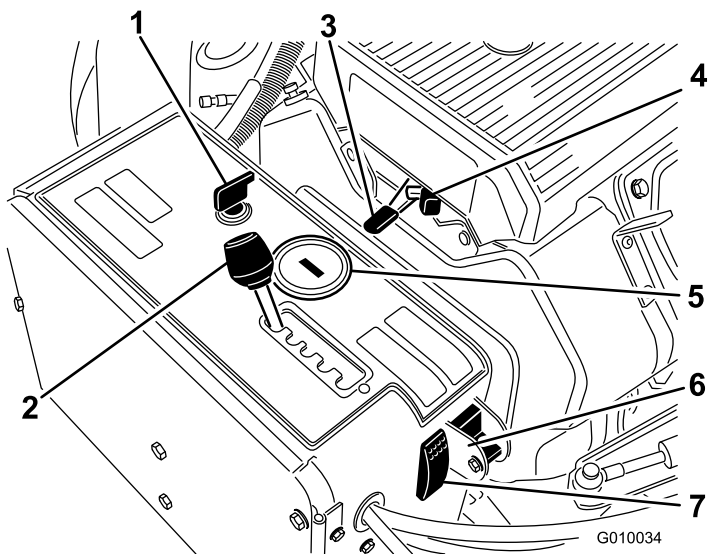

Figure 13

- | | |
|--------------------------|--------------------------|
| 1. Ignition | 5. Hour meter/tachometer |
| 2. Aerator spacing lever | 6. Manual ground follow |
| 3. Throttle | 7. System reset |
| 4. Choke | |

Aerator Spacing Lever

Move aerator spacing lever (Figure 13) to desired hole spacing or to T for transport.

Throttle Control

The throttle (Figure 13) is used to operate engine at various speeds. Moving throttle forward increases engine speed (Fast position); backward decreases engine speed (Slow position). The throttle regulates the speed of the coring head and controls the ground speed of the machine.

Hour Meter/Tachometer

When the engine is off, the hour meter/tachometer (Figure 13) displays the number of hours of operation that have been logged on the machine. When the engine is running, it displays the speed of the engine in revolutions per minute (RPM).

After the first 50 hours of operation and then after every 100 hours (e.g. 150, 250, 350, etc.) the screen displays “CHG OIL” to remind you to change the engine oil. After every 100 hours (e.g. 100, 200, 300, etc.), the screen displays “SVC” to remind you to perform the other maintenance procedures based on a 100, 200, or 500 hour schedule. These reminders come on starting three hours prior to the service interval time and flash at regular intervals for six hours.

Choke

To start a cold engine, close the carburetor choke by moving choke control (Figure 13) fully forward. After the engine

starts, regulate the choke to keep the engine running smoothly. As soon as possible, open the choke by pulling it backward.

Manual Ground Follow Selector Switch

Rotate the switch to the down position to turn off the TrueCore feature (Figure 13) Remove the bolt to access the manual ground switch.

System Reset

Press the system reset switch (Figure 13) to raise the coring head if the system becomes disabled (e.g., engine out of fuel, etc.)

Aeration Depth Lever

Move the lever to the desired depth of aeration (Figure 14)

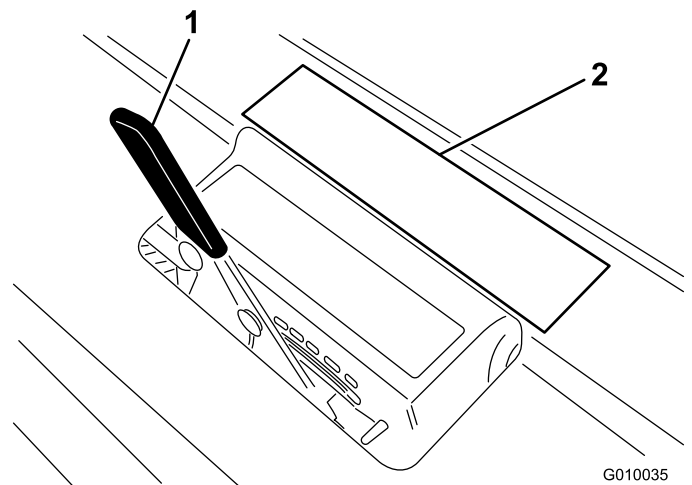

Figure 14

1. Aeration depth lever
2. Depth decal

Specifications

Note: Specifications and design are subject to change without notice.

Width	127.3 cm (50.12 inches)
Wheel base	113 cm (44.5 inches)
Track width	97.3 cm (38.3 inches)
Coring width	122 cm (48 inches)
Length	265.4 cm (104.5 inches)
Height, raised	112 cm (44 inches)
Height, Lowered	112 cm (44 inches)
Height, handle	104 cm (41 inches)
Ground clearance	12.1 cm (4.75 inches)
Forward speed	0–8 kph (0–5 mph)
Reverse speed	0–13 kph (0–8 mph)
Net weight	721 kg (1590 lb)

Attachments/Accessories

A selection of Toro approved attachments and accessories is available for use with the machine to enhance and expand its capabilities. Contact your Authorized Service Dealer or Distributor or go to www.Toro.com for a list of all approved attachments and accessories.

Refer to the following table for the tine head, tine holder, and tine configurations:

Tine Head	Tine Head Spacing	Shank Size	Tine Head Model	Turf Holders Required (qty)	Tines Required
2x5 Mini Tine Head	41 mm (1.6 inch)	9.5 mm (3/8 inch)	09736	110-4365 (2) 110-4366 (1)	60
1x6 Mini Tine Head	32 mm (1.25 inch)	9.5 mm (3/8 inch)	09737	110-4369 (2) 110-4370 (1)	36
3 Tine Head	66 mm (2.6 inch)	22.2 mm (7/8 inch)	09797	110-4357 (1) 110-4358 (1)	18
3 Tine Head	66 mm (2.6 inch)	19.5 mm (3/4 inch)	09794	110-4357 (1) 110-4358 (1)	18
4 Tine Head	51 mm (2 inch)	19.5 mm (3/4 inch)	09796	110-4361 (1) 110-4362 (1)	24
5 Needle Tine Head	41 mm (1.6 inch)	—	09793	110-4365 (2) 110-4366 (1)	30

Operation

Note: Determine the left and right sides of the machine from the normal operating position.

⚠ CAUTION

If you leave the key in the ignition switch, someone could accidentally start the engine and seriously injure you or other bystanders.

Lower the coring head to the ground, set the parking brake, and remove the key from the ignition switch before servicing or making adjustments to the machine.

Adding Fuel

- **Fuel tank capacity:** 26.5 liters (7 US gallons)
- **Recommended Fuel:**
 - For best results, use only clean, fresh (less than 30 days old), unleaded gasoline with an octane rating of 87 or higher ((R+M)/2 rating method).
 - Ethanol: Gasoline with up to 10% ethanol (gasohol) or 15% MTBE (methyl tertiary butyl ether) by volume is acceptable. Ethanol and MTBE are not the same. Gasoline with 15% ethanol (E15) by volume is not approved for use. Never use gasoline that contains more than 10% ethanol by volume, such as E15 (contains 15% ethanol), E20 (contains 20% ethanol), or E85 (contains up to 85% ethanol). Using unapproved gasoline may cause performance problems and/or engine damage which may not be covered under warranty.
 - Do not use gasoline containing methanol.
 - Do not store fuel either in the fuel tank or fuel containers over the winter unless a fuel stabilizer is used.
 - Do not add oil to gasoline.

Important: Do not use fuel additives other than a fuel stabilizer/conditioner. Do not use fuel stabilizers with an alcohol base such as ethanol, methanol, or isopropanol.

⚠ DANGER

In certain conditions, gasoline is extremely flammable and highly explosive. A fire or explosion from gasoline can burn you and others and can damage property.

- Fill the fuel tank outdoors, in an open area, when the engine is cold. Wipe up any gasoline that spills.
- Never fill the fuel tank inside an enclosed trailer.
- Do not fill the fuel tank completely full. Add gasoline to the fuel tank until the level is 6 to 13 mm (1/4 to 1/2 inch) below the bottom of the filler neck. This empty space in the tank allows gasoline to expand.
- Never smoke when handling gasoline, and stay away from an open flame or where gasoline fumes may be ignited by a spark.
- Store gasoline in an approved container and keep it out of the reach of children. Never buy more than a 30-day supply of gasoline.
- Do not operate without entire exhaust system in place and in proper working condition.

⚠ DANGER

In certain conditions during fueling, static electricity can be released causing a spark which can ignite the gasoline vapors. A fire or explosion from gasoline can burn you and others and can damage property.

- Always place gasoline containers on the ground away from your vehicle before filling.
- Do not fill gasoline containers inside a vehicle or on a truck or trailer bed because interior carpets or plastic truck bed liners may insulate the container and slow the loss of any static charge.
- When practical, remove gas-powered equipment from the truck or trailer and refuel the equipment with its wheels on the ground.
- If this is not possible, then refuel such equipment on a truck or trailer from a portable container, rather than from a gasoline dispenser nozzle.
- If a gasoline dispenser nozzle must be used, keep the nozzle in contact with the rim of the fuel tank or container opening at all times until fueling is complete.

Important: Do not use methanol, gasoline containing methanol, or gasohol containing more than 10% ethanol

because the fuel system could be damaged. Do not mix oil with gasoline.

⚠ WARNING

Gasoline is harmful or fatal if swallowed. Long-term exposure to vapors can cause serious injury and illness.

- Avoid prolonged breathing of vapors.
- Keep face away from nozzle and gas tank or conditioner opening.
- Keep gas away from eyes and skin.

Using Stabilizer/Conditioner

Use a fuel stabilizer/conditioner in the traction unit to provide the following benefits:

- Keeps gasoline fresh during storage of 90 days or less. For longer storage it is recommended that the fuel tank be drained.
- Cleans the engine while it runs
- Eliminates gum-like varnish buildup in the fuel system, which causes hard starting

Important: Do not use fuel additives containing methanol or ethanol.

Add the correct amount of gas stabilizer/conditioner to the gas.

Note: A fuel stabilizer/conditioner is most effective when mixed with fresh gasoline. To minimize the chance of varnish deposits in the fuel system, use fuel stabilizer at all times.

Filling the Fuel Tank

1. Stop the engine, remove the key, and wait for all moving parts to stop before leaving the operating position.
2. Clean around the fuel tank cap and remove it (Figure 15).

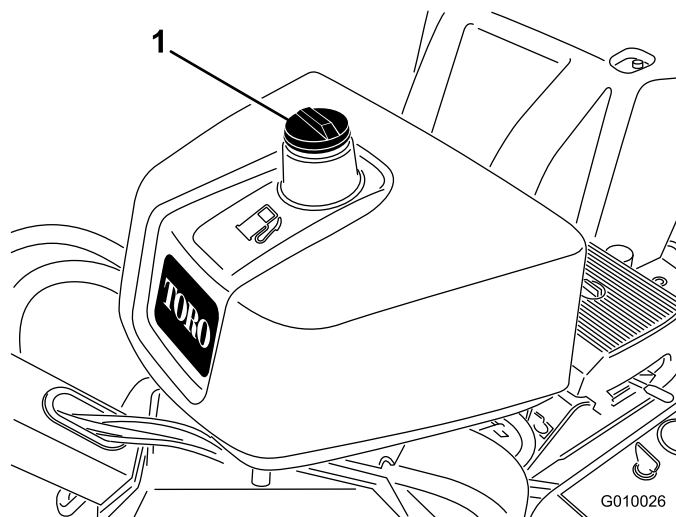

Figure 15

1. Fuel tank cap

3. Add unleaded gasoline to the fuel tank, until the level is 6 mm to 13 mm (1/4 to 1/2 inch) below the bottom of the filler neck.

Important: This space in the tank allows gasoline to expand. Do not fill the fuel tank completely full.

4. Install the fuel tank cap securely.
5. Wipe up any gasoline that may have spilled.

Checking the Engine Oil Level

Service Interval: Before each use or daily (Check the oil when the engine is cold.)

The engine is shipped with oil in the crankcase; however, the oil level must be checked before and after the engine is first started.

Crankcase capacity is approximately 3 liters (3.5 quarts) with the filter.

Use high-quality engine oil as described in Servicing the Engine Oil.

Note: The best time to check the engine oil is when the engine is cool before it has been started for the day. If it has already been run, allow the oil to drain back down to the sump for at least 10 minutes before checking. If the oil level is at or below the “add” mark on the dipstick, add oil to bring the oil level to the “full” mark. **DO NOT OVERFILL.** If the oil level is between the “full” and “add” marks, no oil addition is required.

1. Park the machine on a level surface, stop the engine, remove the key, and wait for all moving parts to stop before leaving the operating position.
2. Clean around the oil dipstick (Figure 16) so dirt cannot fall into the filler hole and damage the engine.

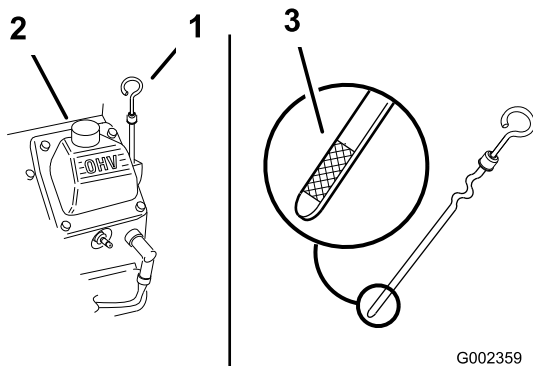

Figure 16

1. Dipstick
2. Filler tube
3. Metal end of the dipstick

3. Remove the dipstick, wipe it clean, and install until it is fully seated (Figure 16).

4. Remove the dipstick and check the oil level on the dipstick.

The oil level should be up to the Full mark on the metal end of the dipstick (Figure 16).

5. If the oil level is below the Full mark, remove the filler tube cap (Figure 16) and add oil until the level reaches the Full mark on the dipstick. **Do not overfill.**

Important: Do not overfill the crankcase with oil because this may cause engine damage. Do not run the engine with oil below the low mark because the engine may be damaged as a result.

6. Install the filler tube cap and dipstick.

Checking the Hydraulic Fluid

Service Interval: Before each use or daily

The hydraulic reservoir is filled at the factory with approximately 6.6 liters (1.75 US gallons) of high quality hydraulic fluid. **Check the level of the hydraulic fluid before the engine is first started and daily thereafter.** The recommended replacement fluid is as follows:

Toro Premium All Season Hydraulic Fluid (Available in 5 gallon pails or 55 gallon drums. See the parts catalog or your Toro distributor for part numbers.)

Alternate fluids: If the Toro fluid is not available, other fluids may be used provided they meet all the following material properties and industry specifications. Toro does not recommend the use of synthetic fluid. Consult with your lubricant distributor to identify a satisfactory product.

Note: Toro will not assume responsibility for damage caused by improper substitutions, so use only products from reputable manufacturers who will stand behind their recommendation.

High Viscosity Index/Low Pour Point Anti-wear Hydraulic Fluid, ISO VG 46

Material Properties:

Viscosity, ASTM D445 cSt @ 40°C 55 to 62
cSt @ 100°C 9.1 to 9.8

Viscosity Index ASTM D2270 140 to 152

Pour Point, ASTM D97 -35°F to -46°F

Industry Specifications:

API GL-4, AGCO Powerfluid 821 XL, Ford New Holland FNHA-2-C-201.00, Kubota UDT, John Deere J20C, Vickers 35VQ25 and Volvo WB-101/BM.

Note: Many hydraulic fluids are almost colorless, making it difficult to spot leaks. A red dye additive for the hydraulic system oil is available in 20 ml. (2/3 oz) bottles. One bottle is sufficient for 15-22 liters (4-6 gallons) of hydraulic oil. Order part no. 44-2500 from your authorized Toro distributor.

Important: For this machine, the Universal Tractor Hydraulic Fluids (UTHF) are recommended for use at typical ambient temperatures of 0 degrees C (32 degrees F) to 35 degrees C (95 degrees F). The Universal Tractor Hydraulic Fluids (UTHF) offer similar performance for those who prefer them, with perhaps some slight loss of efficiency at high ambient temperatures compared to the Type 46/68 fluids.

Important: For operating conditions where sustained ambient temperatures are 35 degrees C (95 degrees F) or higher Toro highly recommends the use of Mobil 1 15W-50 synthetic oil.

Note: When changing from one type of hydraulic fluid to another, be certain to remove all the old fluid from the system, as some fluids are incompatible with others.

Biodegradable Hydraulic Fluid - Mobil 224H
ISO VG 32/46 anti-wear hydraulic fluid
 Mobil EAL Envirosyn H, ISO Grade 68

Note: This synthetic biodegradable hydraulic fluid is not compatible with the UTHF fluids.

Note: When changing from standard fluid to the biodegradable type, be certain to follow approved flushing procedures as published by Mobil. Contact your local Toro Distributor for details.

1. Position the machine on a level surface, stop the engine, remove the key, and wait for all moving parts to stop before leaving the operating position.
2. Unlatch and remove the belt cover (Figure 17).

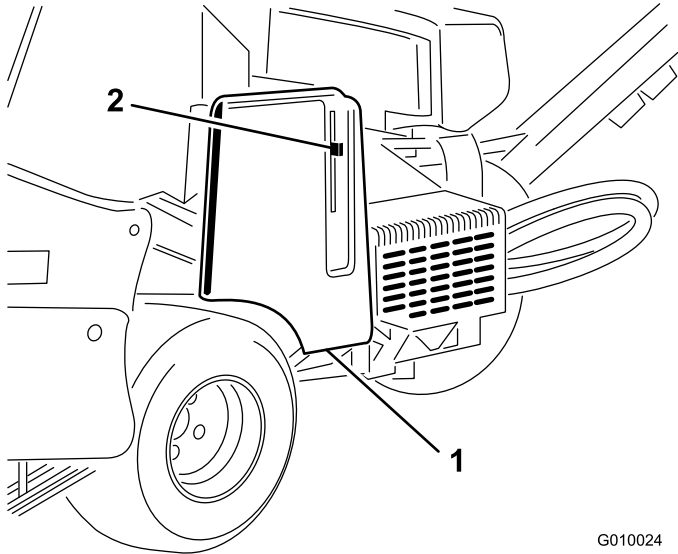

Figure 17

G010024

1. Belt cover
2. Cover latch

3. Clean area around filler neck and cap of hydraulic tank (Figure 18). Remove cap from filler neck.

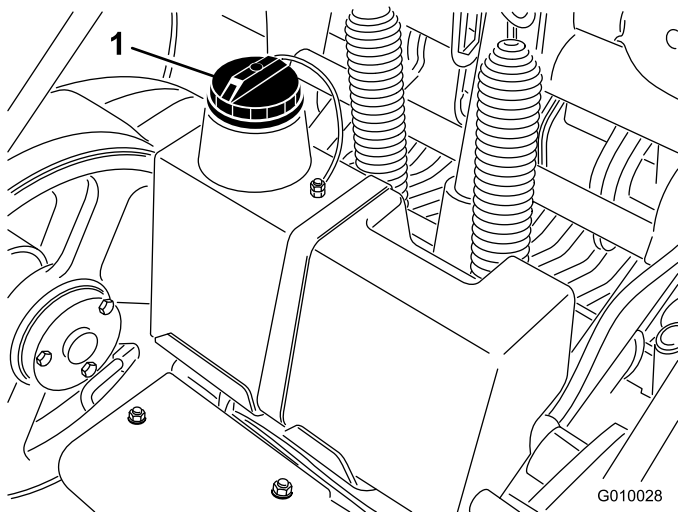

Figure 18

G010028

1. Hydraulic tank cap

4. Remove dipstick from filler neck and wipe it with a clean rag. Insert dipstick into filler neck; then remove it and check level of fluid. Fluid level should be up to mark on dipstick (Figure 19).

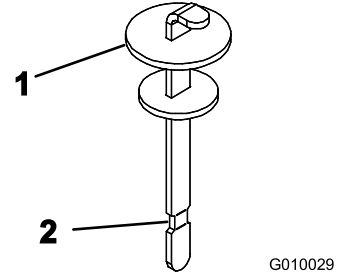

Figure 19

G010029

1. Dipstick
2. Full mark

5. If level is low, add appropriate fluid to raise level to full mark.
6. Install dipstick and cap onto filler neck.

Cleaning the Engine Screen

Service Interval: Before each use or daily (Clean more frequently in dirty operating conditions.)

Before each use, check and clean the engine screen. Remove any buildup of grass, dirt or other debris from the engine air intake screen.

Starting and Stopping the Engine

Starting the Engine

1. Release the traction lever (bail) and set the parking brake.
2. Move the choke control to the On position before starting a cold engine.

Note: A warm or hot engine may not require choking. After the engine starts, move the choke control to the Run position.

3. Move the throttle control to the Fast position before starting a cold engine.
4. Turn the ignition key to start. When the engine starts, release the key.

Important: Do not engage the starter for more than 10 seconds at a time. If the engine fails to start, allow a 30 second cool-down period between attempts. Failure to follow these instructions can burn out the starter motor.

5. After the engine starts, move the choke to the Off position. If the engine stalls or hesitates, move the

choke back to the On position for a few seconds. Then move the throttle lever to desired setting. Repeat this as required.

Stopping the Engine

1. Move the throttle lever to the Slow position.
2. Let the engine idle for 60 seconds.
3. Turn the ignition key to the Off position and remove the key.
4. Close the fuel shut off valve before transporting or storing the aerator.

Important: Ensure that the fuel shut off valve is closed before transporting on a trailer or storing the aerator, as fuel leakage may occur. Set the parking brake before transporting. Make sure to remove the key as the fuel pump may run and cause the battery to lose charge.

⚠ CAUTION

Children or bystanders may be injured if they move or attempt to operate the aerator while it is unattended.

Always remove the ignition key and set the parking brake when leaving the aerator unattended, even if just for a few minutes.

The Safety Interlock System

⚠ CAUTION

If safety interlock switches are disconnected or damaged the aerator could operate unexpectedly causing personal injury.

- Do not tamper with the interlock switches.
- Check the operation of the interlock switches daily and replace any damaged switches before operating the aerator.

Understanding the Safety Interlock System

The safety interlock system is designed to prevent the engine from starting unless the traction bail is in the neutral position.

Testing the Safety Interlock System

Service Interval: Before each use or daily

Test the following:

- The engine must only crank when the traction lever is in the neutral position.
- If the traction lever is released or moved to the neutral position, the coring head should raise and stop rotating.

If the safety system does not operate as described above, have an Authorized Service Distributor repair the safety system immediately.

Installing the Service Latches

Install the service latches before performing service on the coring head or when storing the machine for more than a couple of days.

⚠ DANGER

Any time the coring head is to be serviced, including changing of tines or turf guards, install the service latch to secure head in the raised position to prevent them from lowering and injuring you or bystanders.

1. Raise the coring head.
2. Remove the clip ring securing the service latch in the storage position (Figure 20).

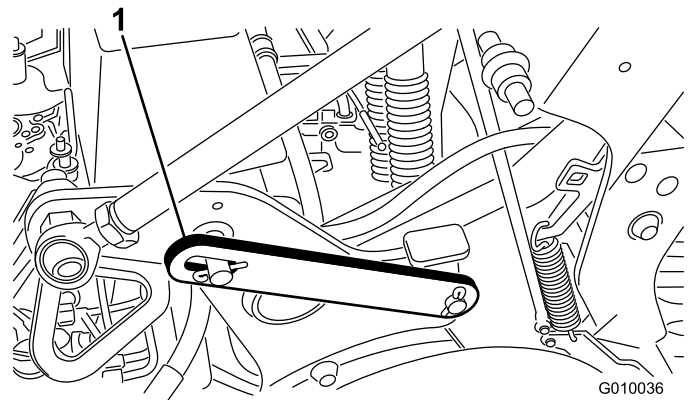

Figure 20

1. Service latch in (lowered) storage position

3. Pivot the service latch rearward and insert it onto the coring head pin (Figure 21). Secure it with the clip ring.

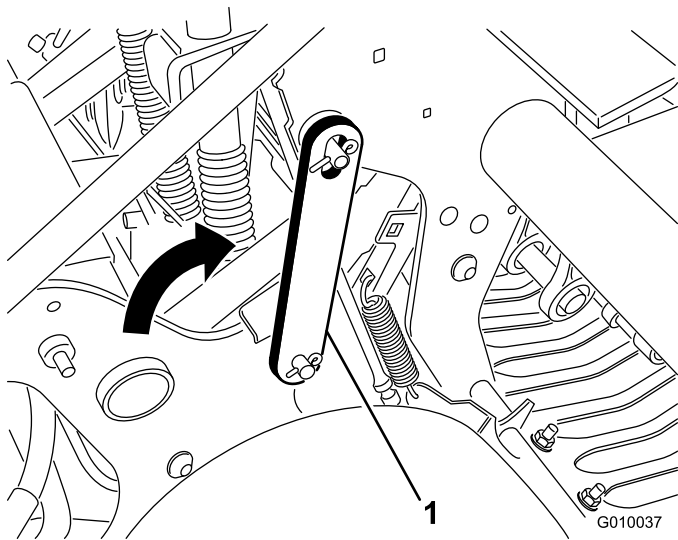

Figure 21

1. Service latch in (raised) locked position

Installing Tine Holders, Turf Guards, and Tines

A wide selection of tine holders, turf guards, and tines are available for the aerator. Choose the required components per the accessory chart in Attachments and Accessories.

1. Raise the coring head and lock it in position with the service latch.
2. Mount a tine holder to each tine arm with 3 bolts (1/2 x 1-1/4 inches) (Figure 22). Torque the bolts to 101.6 N-m (75 ft-lb).

Note: The bolts are provided in the tine holder kits.

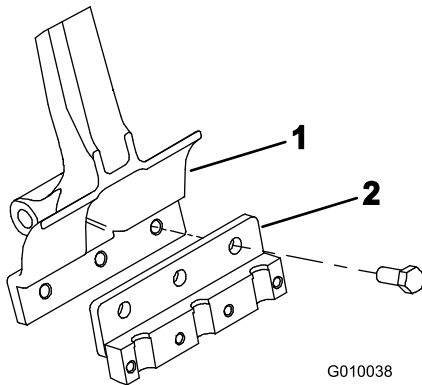

Figure 22

1. Tine arm
2. Tine holder

3. Loosely install the turf guards to the turf guard brackets with 4 turf guard clamps and 12 flange nuts (Figure 23). Do not tighten the fasteners.

Note: The turf guard clamps and flange nuts are shipped secured to the turf guard brackets (Figure 23).

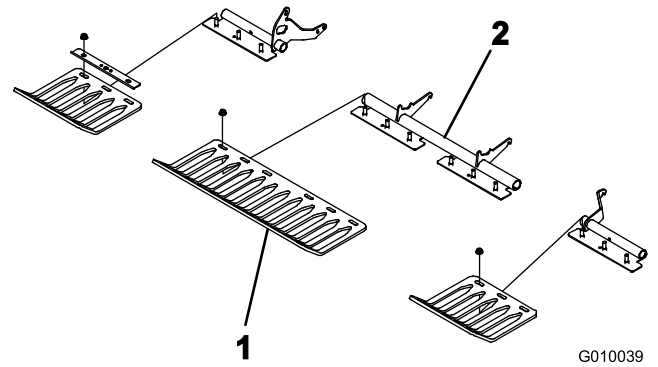

Figure 23

1. Turf guard
2. Turf guard clamp

4. Loosely install a tine clamp to each tine holder with 4 bolts (3/8 x 1-1/2 inches) (Figure 24). Do not tighten the bolts.

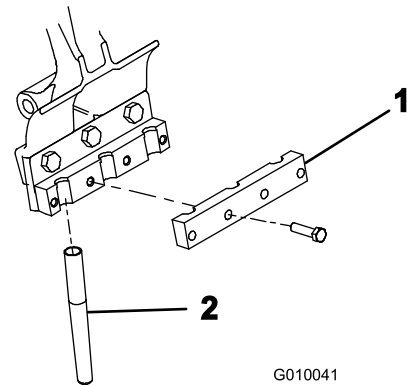

Figure 24

1. Tine clamp
2. Tine

5. Install tines into the #2 and #5 tine holders (Figure 25) Tighten the bolts.

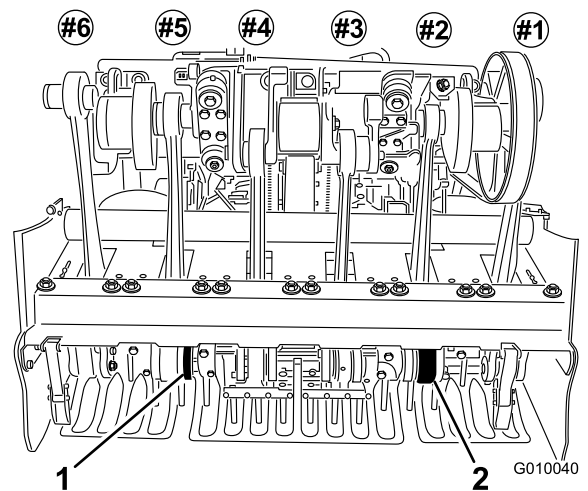

Figure 25

1. Number 5 tine holder
2. Number 2 tine holder

6. Check that the tines line up with the center of the gaps in the turf guards (Figure 26). Adjust the turf guards as required and tighten the nuts.

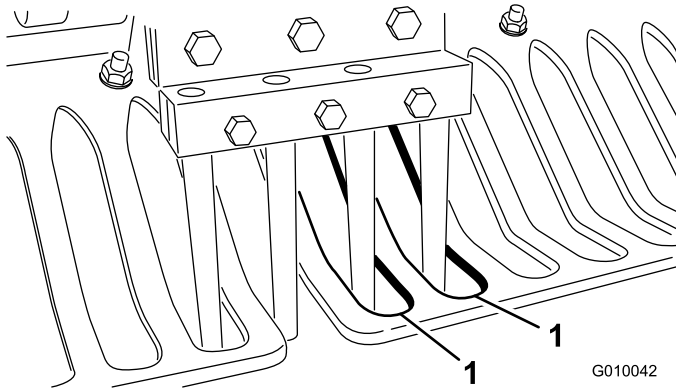

Figure 26

1. Gaps in the turf guards

7. Install the remaining tines into the #1, 3, 4, and 6 tine holders. Torque all tine holder bolts to 40.6 N-m (30 ft-lb)

Replacing Tines

Refer to Installing Tine Holders, Turf Guards, and Tines for illustrations.

1. Raise the coring head and lock it in position with the service latch.
2. Loosen the tine holder retaining bolts and remove the old tines.
3. Insert the new tines into the tine holder.
4. Tighten the bolts to the recommended torque level.
5. Repeat this procedure on the remaining arms.

Setting the Coring Depth

To set the coring depth of the aerator, proceed as follows:

1. Select the preferred tine for your application.
2. Lay the tine on the tine depth decal (Figure 27) with one end lined up with the desired depth of aeration (refer to the tine overlay on the decal).

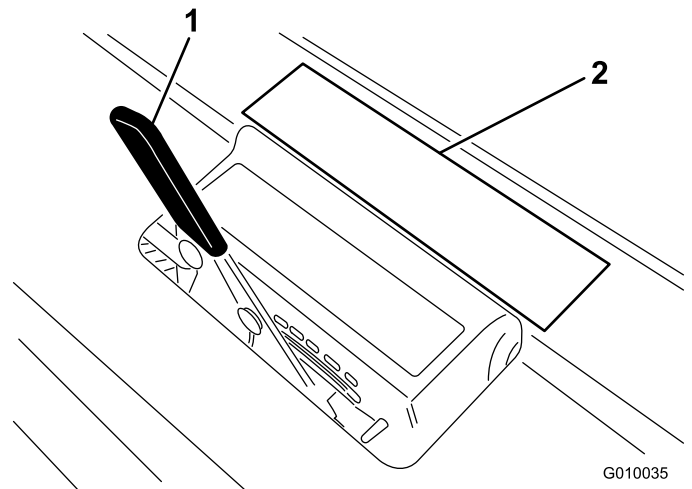

Figure 27

1. Aeration depth lever
2. Overlay on decal

3. Determine which letter setting the other end of the tine lines up with and set the depth control lever to the corresponding letter setting.

Note: As the tine wears, you may be able to reset the depth setting to account for that wear. For instance, if your new tine depth setting has you in the G setting, you can reset to the H setting after 6 mm (1/4 inch) of tine wear.

Setting Up Manual Ground Following

The only time the manual depth setting spacers are required is if the TrueCore® ground following system is not functioning due to damage to the feedback system (turf guards, tie rod, and actuator assembly) or if maximum coring depth is required.

1. Remove the lynch pin retaining the spacers and depth pins (Figure 28).

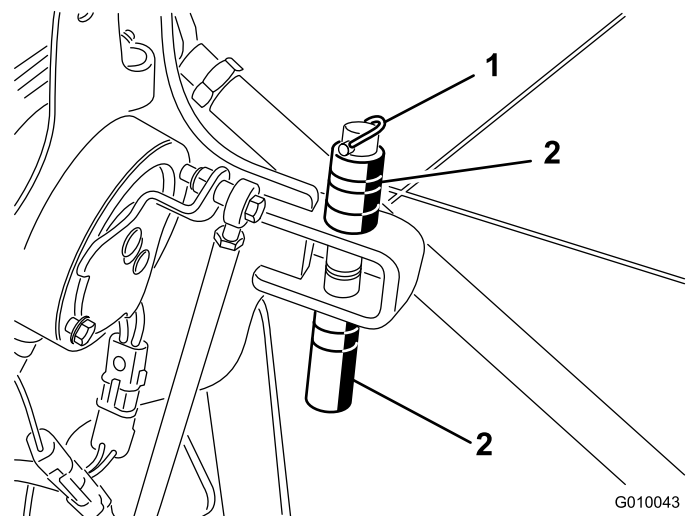

Figure 28

1. Lynch pin
2. Spacers and depth pin

2. Position the spacers above or below the bracket to attain the desired coring depth.
 - Thick spacers equate to 19 mm (3/4 inch) increments.
 - Thin spacer equates to 9.5 mm (3/8 inch) depth increment.
 - With all spacers on the top side, the depth setting is 10.7 cm (4-1/4 inches).
3. Remove locking bolt and nut from selector switch (Figure 29).

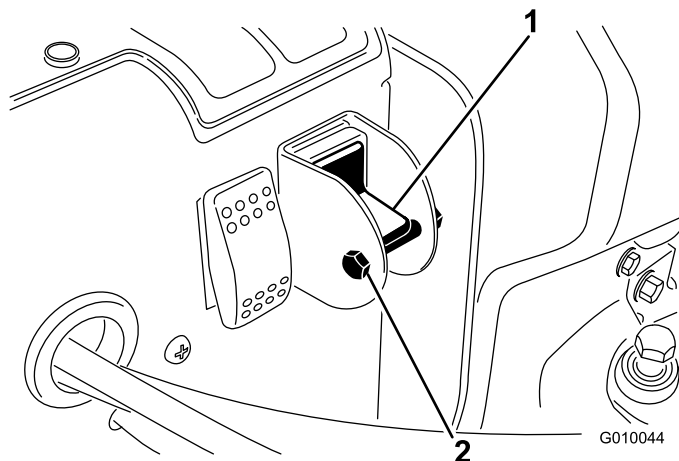

Figure 29

1. Manual ground following selector switch
2. Bolt and nut

4. Rotate the switch to the down position to turn off True Core feature.
5. Install the locking bolt and nut to ensure that the setting is not accidentally changed.

Pushing/Pulling the Aerator by Hand

Important: Never tow the aerator faster than 1 MPH because hydraulic component damage may occur.

1. Set the parking brake, turn the ignition key to the Off position, and remove the ignition key.
2. Locate the by-pass valve between the engine and hydrostatic pump (Figure 30).
3. Using a 5/8 inch wrench, rotate the by-pass valve counterclockwise 1 turn. This allows the hydraulic fluid to by-pass the pump enabling the wheels to turn (Figure 30).

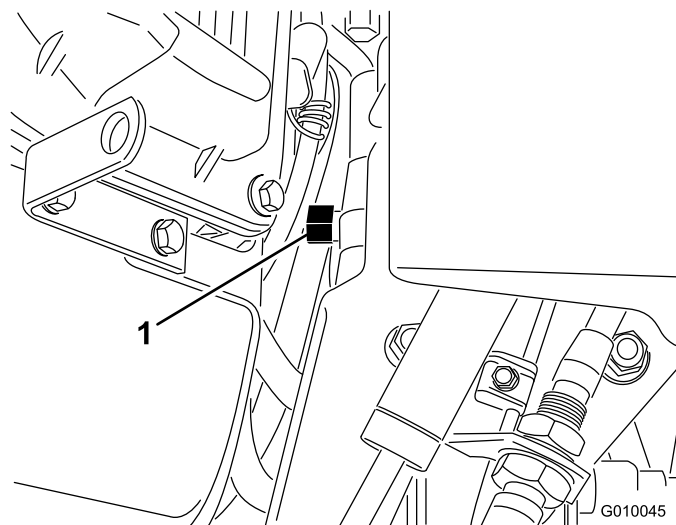

Figure 30

1. By-pass valve

Important: Do not rotate the by-pass valve more than 1 turn. This prevents the valve from coming out of the body and causing fluid to run out.

Important: Do not push/pull the aerator more than 100 ft or faster than 1 MPH because hydraulic component damage may occur.

4. Disengage the parking brake before pushing/pulling.

Important: Do not operate engine with the by-pass valve open for more than 10–15 seconds.

5. To operate the aerator again, rotate the by-pass valve clockwise 1 turn (Figure 30).

Note: Do not over tighten the by-pass valve.

Note: The aerator will not drive unless the by-pass valve is turned closed. Do not try to operate traction system with the by-pass open.

Resetting the System Control Circuit

If the coring head is ever left in the aerating position (run out of fuel, forget to install service latch for storage, mechanical failure of engine/pump, etc.) the electrical system that controls the hydraulic solenoid coils and the electric clutch is disabled to prevent unintended movement of the coring head without the deliberate action of resetting the system.

To reset the system after engine is started, press the rocker switch (Figure 31) to raise the coring head and reset the electrical control circuit.

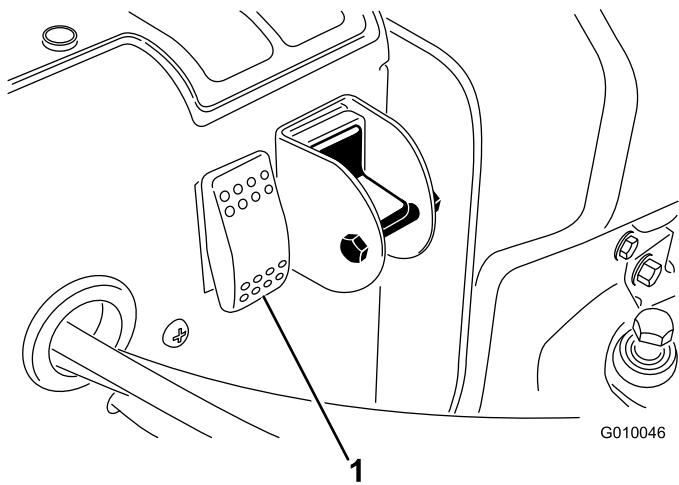

Figure 31

1. Circuit reset switch

Moving the Machine when the Coring Head is Stranded in the Lowered Position

In the event that the engine fails or cannot be restarted with the coring head lowered and tines are engaged in the soil, proceed as follows:

1. Remove the tine holders from the stomper arms.
2. Open the by-pass valve one turn.
3. Pull/push the aerator to a nearby location to continue service or load onto a trailer.

Important: Do not pull/push aerator for more than 100 feet and no faster than 1 MPH because hydraulic damage may occur.

Transporting the Aerator

Use a heavy-duty trailer or truck to transport the aerator. Ensure that the trailer or truck has all necessary lighting and marking as required by law. Please carefully read all the safety instructions. Knowing this information could help you, your family, pets, or bystanders avoid injury.

Important: Do not use the Hydroject trailer/tote to trailer this aerator.

Trailer Recommendations

Weight	721 kg (1590 lb) or 805 kg (1775 lb) with two optional weights
Width	130 cm (51 inches) minimum
Length	267 cm (105 inches) minimum
Ramp Angle	3.5/12 pitch (16 degrees) maximum
Load Direction	Coring head forward (preferred)
Vehicle Tow Capacity	Greater than gross trailer weight (GTW)

Transport the aerator as follows:

1. Set the parking brake and block the wheels.
2. Load the aerator onto the trailer.

Use extreme caution when loading the aerator on a trailer or truck. One full width ramp that is wide enough to extend beyond the rear tires is required.

The ramp should be long enough so that the angles do not exceed 16 degrees. A steeper angle may cause aerator components to get caught as the unit moves from ramp to trailer or truck. Steeper angles may also cause the unit to tip backward. If loading on or near a slope, position the trailer or truck so it is on the down side of the slope and the ramp extends up the slope. This will minimize the ramp angle. The trailer or truck should be as level as possible. Load the aerator with the coring head going up the ramp first.

Important: Do not attempt to turn the unit while on the ramp; you may lose control and drive off the side.

Avoid sudden acceleration when driving up a ramp and sudden deceleration when backing down a ramp. Both maneuvers can cause the unit to tip backward.

3. Securely fasten the aerator tie downs (Figure 32 through Figure 34) to the trailer or truck with straps, chains, cable, or ropes.
4. Secure the trailer to the towing vehicle with safety chains.

▲ WARNING

Driving on street or roadway without turn signals, lights, reflective markings, or a slow moving vehicle emblem is dangerous and can lead to accidents causing personal injury.

Do not operate aerator on a public street or roadway.

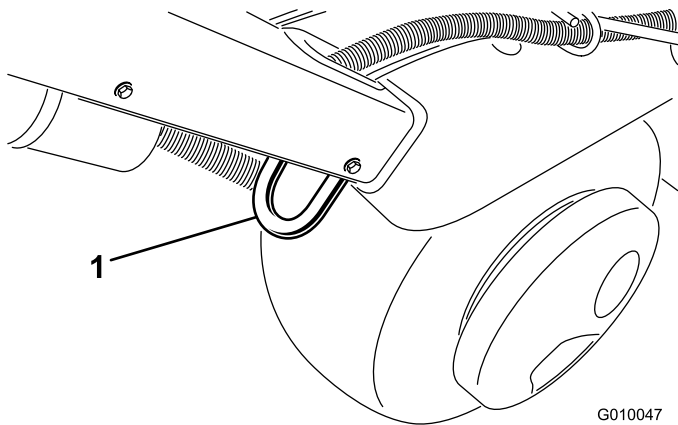

Figure 32

1. Tie down

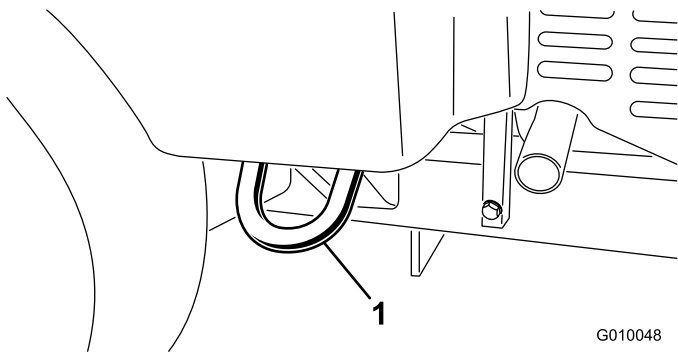

Figure 33

1. Tie down

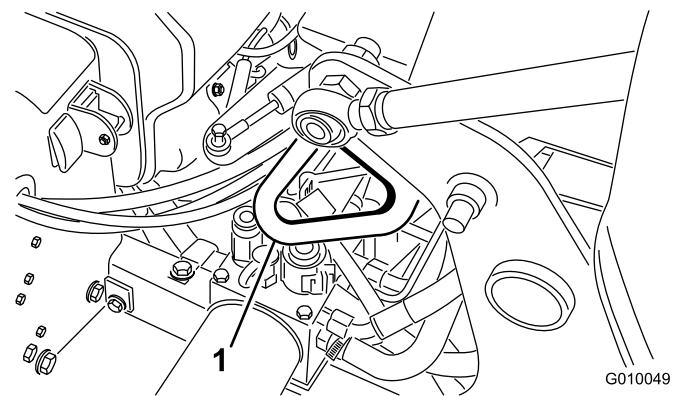

Figure 34

1. Tie down

Using the Line Marker

Use the line marker to align aeration rows (Figure 35).

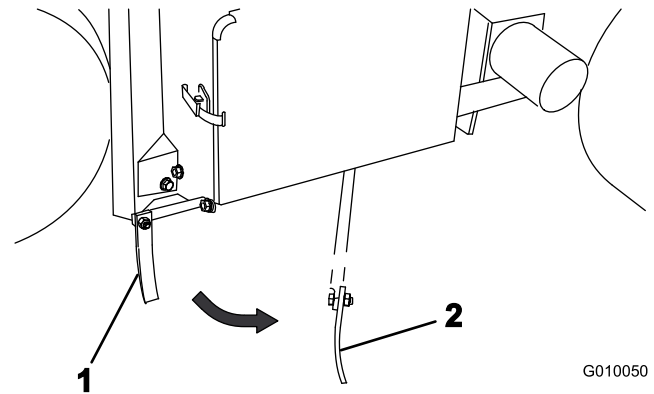

Figure 35

1. Line marker (storage position)
2. Line marker (alignment position)

Adjusting the Weight Transfer

The machine is designed to transfer weight from the traction unit to the coring head to help maintain hole depth in various soil structures. However, if the soil structure is firm enough to not allow full aeration depth some additional weight transfer may be required. To increase the down pressure of the weight transfer springs, proceed as follows:

⚠ WARNING

Sudden release of the spring plates could cause injury.

Acquire the help of another person to help adjust the weight transfer spring.

1. Loosen the carriage bolt nuts securing the spring brackets to the coring head (Figure 36). Do not remove them.

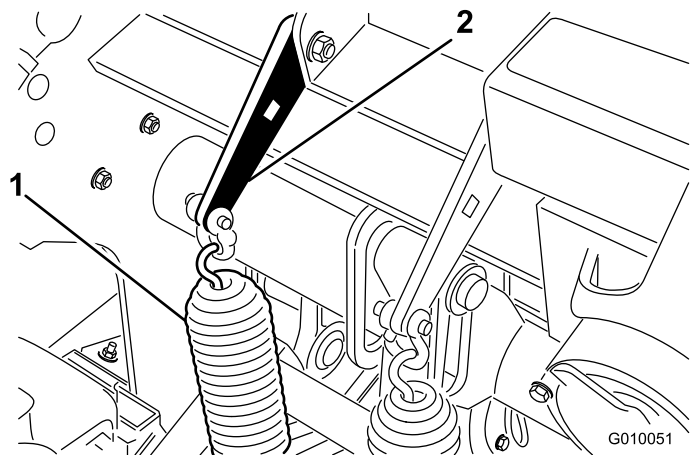

Figure 36

1. Weight transfer springs
2. Spring plate

2. Insert a 1/2 inch ratchet or breaker bar into the square hole in the spring plate (Figure 37).

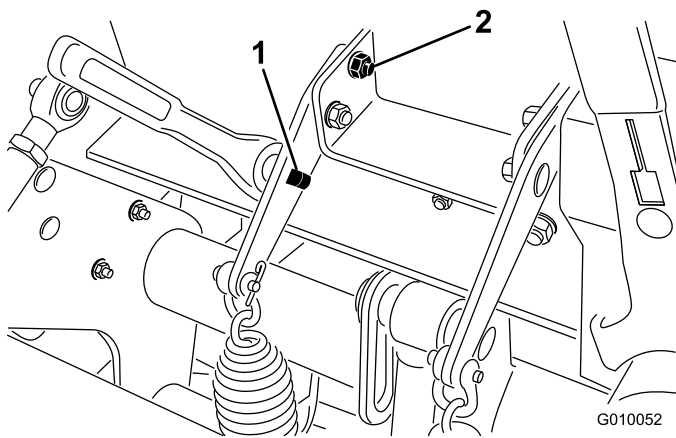

Figure 37

1. Square hole in bracket
2. Rear carriage bolt

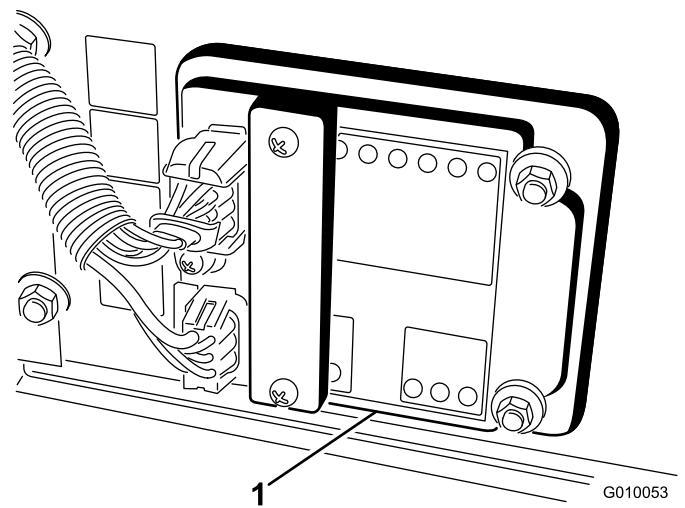

Figure 38

1. Aerator control module

3. Hold the ratchet or breaker bar to relieve the tension on the spring plate and remove the rear carriage bolt.
4. Rotate the spring plate until it is aligned with the other hole, insert the carriage bolt, and tighten the nuts.

Note: Rotating the spring plates upward will increase the weight transfer.

Adding Additional Weight

With the increased weight transfer, it is possible to aerate firm enough ground that the weight transfer begins to lift the rear two tires off the ground. This may lead to irregular hole spacing.

If this occurs, an additional weight plate can be added to the rear frame axle tube. Each cast weight adds 28.5 kg (63 lb) to the machine. Up to two plates can be added. Refer to the *Parts Catalog* for these part numbers.

Aerator Control Module (ACM)

The Aerator Control Module is a potted electronic device produced in a one size fits all configuration. The module uses solid state and mechanical components to monitor and control electrical features required for safe product operation.

The module monitors inputs including head low, head high, transport, aerate, and ground following. The module is divided into inputs and outputs. Inputs and outputs are identified by green LED indicators mounted on the printed circuit board. Power is identified by a red LED indicator.

The start circuit input is energized by 12 VDC. All other inputs are energized when the circuit is closed to ground. Each input has an LED that is illuminated when the specific circuit is energized. Use the input LED's for switch and input circuit troubleshooting.

Output circuits are energized by an appropriate set of input conditions. The three outputs include SVL, SVR, and SVQ. Output LED's monitor relay conditions indicating the presence of voltage at one of three specific output terminals.

Output circuits do not determine output device integrity, so electrical troubleshooting includes output LED inspection and conventional device and wire harness integrity testing. Measure disconnected component impedance, impedance through wire harness (disconnect at ACM), or by temporarily test energizing the specific component.

The ACM does not connect to an external computer or hand held device, cannot be reprogrammed, and does not record intermittent fault troubleshooting data.

The decal on the ACM only includes symbols. Three LED output symbols are shown in the output box. All other LED's are inputs. The chart below identifies the symbols.

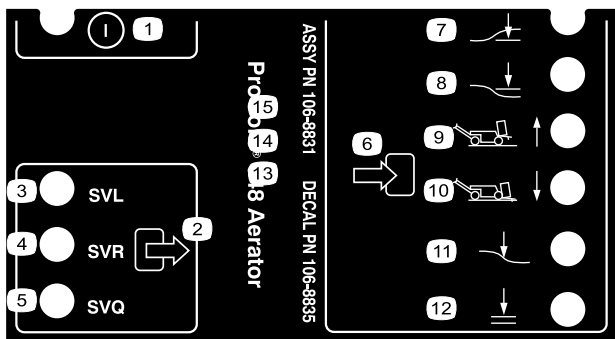

Figure 39

- | | |
|-------------------------|----------------------|
| 1. On/off | 7. Head low |
| 2. Output | 8. Head high |
| 3. Solenoid valve lower | 9. Transport (1) |
| 4. Solenoid valve raise | 10. Aerate (4) |
| 5. Solenoid valve quick | 11. Ground following |
| 6. Input | 12. OK to lower |

Here are the logical troubleshooting steps for the ACM device.

- Determine the output fault you are trying to resolve.
- Move the key switch to the On position and ensure the red power LED is illuminated.
- Move all input switches to ensure all LED's change state.
- Position input devices at the appropriate position to achieve the appropriate output.
- If specific output LED is illuminated without appropriate output function, check output harness, connections, and component. Repair as required.
- If specific output LED is not illuminated, check both fuses.
- If specific output LED is not illuminated and inputs are in appropriate condition, install new ACM and determine if fault disappears.

Operating Tips

General

⚠ WARNING

Always be aware of obstacles that may be in the area of operation. Plan your aeration path to avoid contact with any obstacle by you or the machine.

- Make very gradual turns when aerating. Never make sharp turns with the coring head engaged. Plan your aeration path before lowering the aerator.
- Always maintain awareness of what lies ahead in the direction of forward travel. Avoid operation in close proximity of buildings, fences, and other equipment.

- Look behind frequently to ensure that the machine is operating properly and alignment is maintained with previous passes.
- Always clear the area of all damaged machine parts, such as broken tines, etc., to prevent their being picked up by mowers or other turf maintenance equipment.
- Replace broken tines and inspect and correct damage to those still usable. Repair any other machine damage before commencing operation.
- When aerating with less than the full width of the machine, the tines may be removed but the tines heads should remain installed on the stomper arms to insure proper balance and operation of the machine.
- The machine will aerate deeper than most greens aerators. On native or modified push-up greens and tees, the deeper depth and longer hollow tines may have difficulty ejecting the complete core. This is due to harder native soil that sticks in the end of the tine. Side-eject greens/tees tines from Toro will stay cleaner and reduce the time required to clean the tines out. This condition is eventually eliminated with continued aeration and top-dressing programs.

Hard Ground

If the ground is too firm to obtain the desired coring depth, the coring head can get into a bouncing rhythm. This is due to the hard pan the tines are attempting to penetrate. This condition can be corrected by attempting the following:

- Do not aerate if ground is too hard or dry, best results are obtained after a rain or when turf has been watered the previous day.
- Change to a 3-tine head, if attempting to use the 4-tine head or reduce the number of tines per stomper arm. Attempt to maintain a symmetrical tine configuration to evenly load the stomper arms.
- Reduce aerator penetration (depth setting), if ground is hard packed. Clean up cores, water turf, and re-aerate at a deeper penetration.

Aeration of soil types built on top of hard subsoils (i.e. soil/sand placed over rocky soil) can cause undesired hole quality. This is caused when the aeration depth is greater than the built up soil and the subsoil is too hard to penetrate. When the tines contact this harder sub soil the aerator may lift and cause the top of the holes to become elongated. Reduce the aerating depth sufficiently to avoid penetration into the hard subsoil.

Entrance/Exit

If the entrance/exit hole quality is deteriorating, the clutch may not be engaging soon enough. Check the following:

- The no. 3 switch location on H-Frame
- Clutch wear/slippage

If the hole quality upon entrance is slotted (pulled forward) or the coring head fails to engage before contacting the turf, the engagement position switch may require adjustment.

- Verify that the switch assembly along side the H-Frame is no more than 1.5 mm (0.06 inches) from the target plate
- Verify that the #3 switch is functioning properly.
- If needed, loosen the switch mounting plate and lift to its highest position and re-secure the mounting plate. The higher the switch, the sooner the clutch engages.

If the coring head fails to start before entrance and the position switch is located as high as permissible, the electric clutch may have deteriorated sufficiently to cause a delay in engagement. Contact your Toro distributor or refer to the *Service Manual*.

Mini Tine (Quad Tine)

The mini-tine head developed by Toro is a very fast way to aerate due to the double row design. This coring head requires the hole spacing to be set at 6.3 cm (2.5 inches). Ground speed is critical to maintain the appearance of 3.2 cm (1.25 inch) hole spacing. Refer to the hole spacing adjustment section if your hole spacing requires a small change.

With the mini tine head or larger solid tine use, the turf root structure is important to preventing turf damage due to tearing of the root zone. If the center two arms begin to lift the turf or damage to the root zone is excessive, proceed as follows:

- Increase the hole spacing
- Decrease tine size
- Decrease tine depth
- Remove some of the tines

This damage is caused by the lifting action that solid tines create when pulled from the turf. This lift can tear the root zone if the density of tines or diameter of tines is too high.

Front Hole Dimpled or Pushed (Solid Tines or Softer Soil Conditions)

When aerating with longer solid tines (i.e. 3/8 x 4 inches long) or needle type tines, the front of the holes may become slotted or tufted. To regain excellent hole quality for this configuration, slow the engine high idle speed down to 2800–2900 RPM. The hole spacing is not affected as the traction and coring head speeds are both a function of engine speed.

If slowing the engine speed does not work to the remedy hole quality for the larger solid tines, the Roto-Link damper mechanism may require a stiffer setting. A stiffer Roto-Link setting may help eliminate the front of the hole from being deformed. However, under most conditions, the factory setting works best.

Note: Alter half of the Roto-Links (3 arms) and test the difference on a sample plot.

1. Remove the lock nuts securing the Roto-Link damper assembly to the coring head frame.
2. Remove the top damper–spacer (1.25 cm (1/2 inch) thick) and re-secure the Roto-Link damper assembly to the coring head frame. Be sure to use the hardened D washer.
3. Loosen the bolts securing the bumper plate.
4. Slide the bumper plate forward and secure the bolts. This allows the Roto-Link bumpers to oscillate properly.

Take the aerator to a test area and compare the hole quality. If improved, complete this procedure with remaining Roto-Link damper assemblies.

Note: This repositioning of the Roto-Link damper must be reversed if the tine type is changed back to a coring style tine or any of the mini–tines.

Upon Completion

After daily use, thoroughly wash the machine with a garden hose without a nozzle so contamination and seal and bearing damage due to excessive water pressure will be avoided. A brush may be used to remove caked-on material. Use mild detergent to clean the covers. Applying a coat of auto wax periodically will retain the cover's glossy finish. After cleaning, inspect for machine damage, oil leakage, component and tine wear.

Remove, clean, and oil the tines. Spray a light oil mist on coring head bearings (crank & damper links).

Secure the service latch if the aerator is to be stored for more than a couple days.

Maintenance

Note: Determine the left and right sides of the machine from the normal operating position.

Recommended Maintenance Schedule(s)

Maintenance Service Interval	Maintenance Procedure
After the first 8 hours	<ul style="list-style-type: none"> • Adjust the pump belt. • Change the hydraulic fluid and the return and charge filters. • Check the torque of the coring head fasteners, tiller handle fasteners and wheel lug nuts.
After the first 50 hours	<ul style="list-style-type: none"> • Change the engine oil and filter.
Before each use or daily	<ul style="list-style-type: none"> • Check the engine oil level. (Check the oil when the engine is cold.) • Check the hydraulic fluid level. • Remove debris from the engine screen. (Clean more frequently in dirty operating conditions.) • Test the safety interlock system. • Check the hydraulic lines.
Every 25 hours	<ul style="list-style-type: none"> • Clean the foam air filter element and check the paper element for damage. • Check the electrolyte level and clean the battery. • Check the battery cable connections.
Every 50 hours	<ul style="list-style-type: none"> • Check the tire pressure.
Every 100 hours	<ul style="list-style-type: none"> • Replace the paper air filter element. • Change the engine oil and filter. • Replace the fuel filter.
Every 200 hours	<ul style="list-style-type: none"> • Check the spark plugs. • Change the hydraulic fluid and the return and charge filters.
Every 500 hours	<ul style="list-style-type: none"> • Inspect the coring head bearings, if needed, replace.
Before storage	<ul style="list-style-type: none"> • Refer to the Storage section for procedures necessary to perform before storing the machine for more than 30 days.
Yearly	<ul style="list-style-type: none"> • Check the coring head bearings. • Inspect the belts for wear and damage.

Daily Maintenance Checklist

Duplicate this page for routine use.

Maintenance Check Item	For the week of:						
	Mon.	Tues.	Wed.	Thurs.	Fri.	Sat.	Sun.
Check the safety interlock operation.							
Check parking brake operation.							
Check the engine oil level.							
Check fuel level							
Check the air cleaner.							
Check the engine for debris.							
Check unusual engine noises.							
Check unusual operating noises.							
Check the hydraulic fluid level.							
Check the hydraulic hoses for damage.							
Check for fluid leaks.							
Check instrument operation.							
Check the condition of the tines.							
Touch up damaged paint.							

Notation for Areas of Concern

Inspection performed by:		
Item	Date	Information
1		
2		
3		
4		
5		
6		
7		
8		

Important: Refer to your *Engine Operator's Manual* for additional maintenance procedures.

⚠ CAUTION

If you leave the key in the ignition switch, someone could accidentally start the engine and seriously injure you or other bystanders.

Remove the key from the ignition and disconnect the wire from the spark plug(s) before you do any maintenance. Set the wire aside so that it does not accidentally contact the spark plug.

Premaintenance Procedures

Important: The fasteners on the covers of this machine are designed to remain on the cover after removal. Loosen all of the fasteners on each cover a few turns so

that the cover is loose but still attached, then go back and loosen them until the cover comes free. This will prevent you from accidentally stripping the bolts free of the retainers.

Jacking Instructions

⚠ CAUTION

When changing attachments, tires, or performing other service, use the correct blocks, hoists, and jacks. Make sure the machine is parked on a solid, level surface such as a concrete floor. Prior to raising the machine, remove any attachments that may interfere with the safe and proper raising of the machine. Always chock or block wheels. Use jack stands or solid wood blocks to support the raised machine. If the machine is not properly supported by blocks or jack stands, the machine may move or fall, which may result in personal injury.

Jacking the Front End

1. Set the parking brake and chock the rear tires to prevent the machine from moving.

Important: To prevent wheel motor damage, *do not* use front wheel motor as a jacking point.

2. Position the jack securely under the front of the frame (Figure 40).

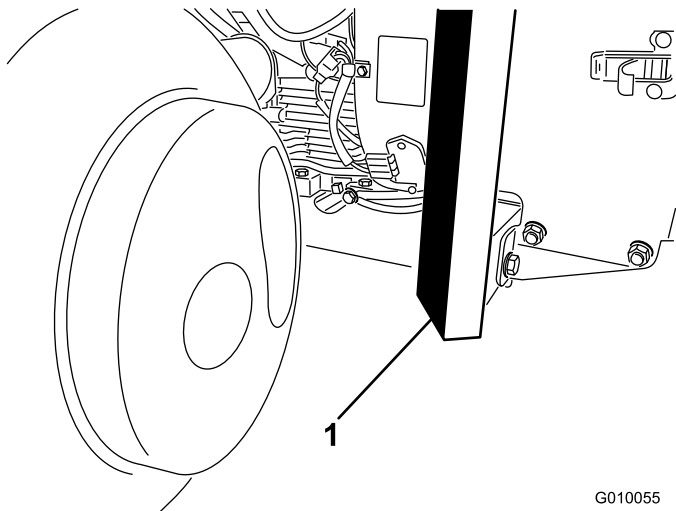

Figure 40

G010055

1. Frame

3. Jack the front of the machine off the ground.
4. Position the jack stands or hardwood blocks under the front of the frame to support the machine.

Jacking the Rear End

1. Chock the front tire to prevent the machine from moving.

Important: To prevent wheel motor damage, *do not* use rear wheel motor as a jacking point.

2. Place the jack securely under the frame plate just inside of the rear wheel (Figure 41).

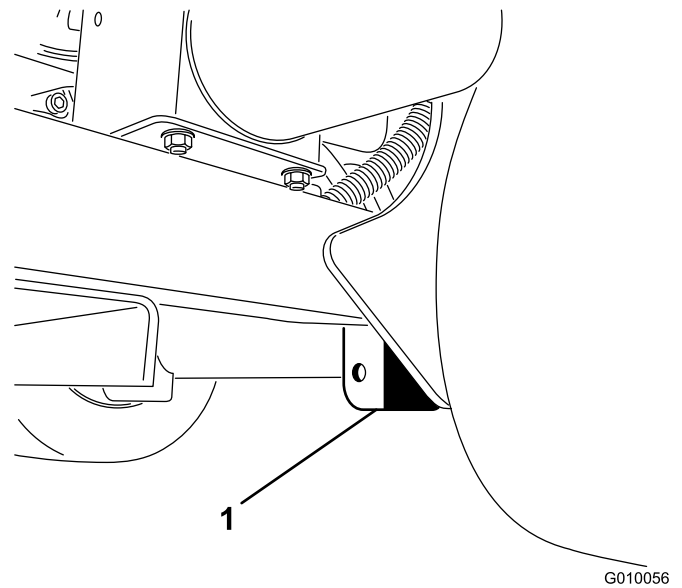

Figure 41

1. Frame plate

Note: If available, a hoist can be used to lift the rear of the machine. Use the eyelets in the coring head bearing housings as hoist attachment points (Figure 42).

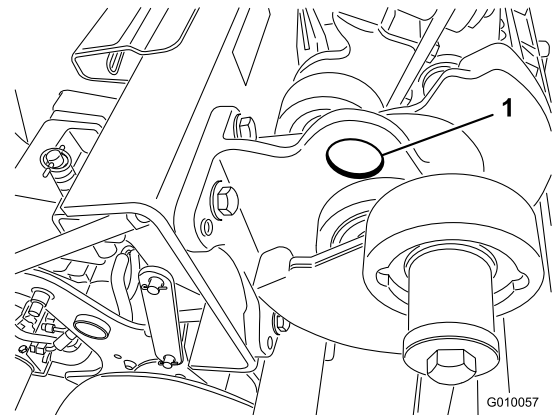

Figure 42

1. Eyelet

3. Jack (or lift) the rear of the machine off the ground.
4. Position the jack stands or hardwood blocks under the frame to support the machine.

Lubrication

Checking the Coring Head Bearings

Service Interval: Yearly—Check the coring head bearings.

Every 500 hours—Inspect the coring head bearings, if needed, replace.

The aerator has no grease fittings that must be lubricated.

Important: Bearings rarely fail from defects in materials or workmanship. The most common reason for failure is moisture and contamination working its way past the protective seals. Bearings that are greased will rely upon regular maintenance to purge harmful debris from the bearing area. Sealed bearings rely on an initial fill of special grease and a robust integral seal to keep contaminants and moisture out of the rolling elements.

The sealed bearings require no lubrication or short term maintenance. This minimizes routine service required and reduces the potential of turf damage due to grease contamination. These sealed bearing packages will provide good performance and life under normal use, but periodic inspections of bearing condition and seal integrity should be conducted to avoid downtime. These bearings should be inspected seasonally and replaced if damaged or worn. Bearings should operate smoothly with no detrimental characteristics such as high heat, noise, looseness, or rust weeping.

Due to the operating conditions these bearing/seal packages are subject to (e.g., sand, turf chemicals, water, impacts, etc.) they are considered normal wear items. Bearings that fail due to causes other than defects in materials or workmanship are typically not covered under warranty.

Note: Bearing life can be negatively affected by improper wash down procedures. Do not wash down the unit when it is still hot and avoid directing high-pressure or high volume spray at the bearings.

It is not uncommon for new bearings to purge some grease out the seals on a new unit. This purged grease will turn black in color due to collection of debris and not due to excessive heat. It is good practice to wipe this excess grease from the seals after the initial 8 hours. There may always appear to be a wet area around the seal lip. This is generally not detrimental to bearing life, but keeps the seal lip lubricated.

Engine Maintenance

Servicing the Air Cleaner

Service Interval: Every 25 hours—Clean the foam air filter element and check the paper element for damage.

Every 100 hours—Replace the paper air filter element.

Removing the Filters

1. Stop the engine, set the parking brake, and remove the key.
2. Clean around the air cleaner to prevent dirt from getting into the engine and causing damage.
3. Unscrew the knob and remove the air cleaner cover (Figure 43).

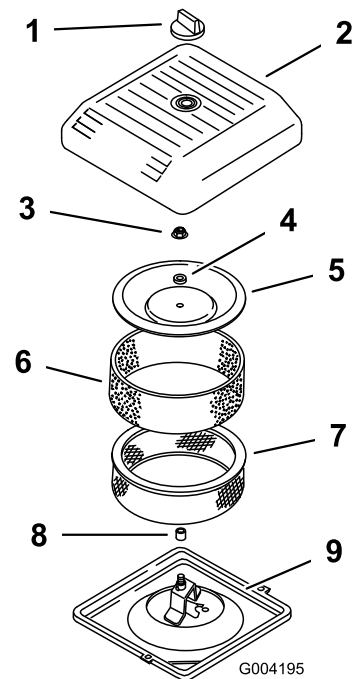

Figure 43

- | | |
|----------------------|---------------------|
| 1. Knob | 6. Foam pre-filter |
| 2. Air cleaner cover | 7. Paper filter |
| 3. Cover nut | 8. Rubber seal |
| 4. Spacer | 9. Air cleaner base |
| 5. Cover | |

-
4. Carefully slide the foam pre-filter off of the paper element (Figure 43).
 5. Unscrew the cover nut and remove the cover, spacer and paper filter (Figure 43).

Cleaning the Foam Pre-filter

Important: Replace the foam element if it is torn or worn.

1. Wash the foam pre-filter in liquid soap and warm water. When clean, rinse it thoroughly.
2. Dry the pre-filter by squeezing it in a clean cloth (do not wring).
3. Put one or two ounces of oil on the pre-filter (Figure 44).

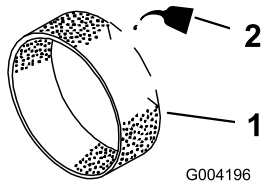

Figure 44

1. Foam element
2. Oil

4. Squeeze the pre-filter to distribute the oil.
5. Inspect the paper filter for tears, an oily film, and damage to the rubber seal (Figure 45).

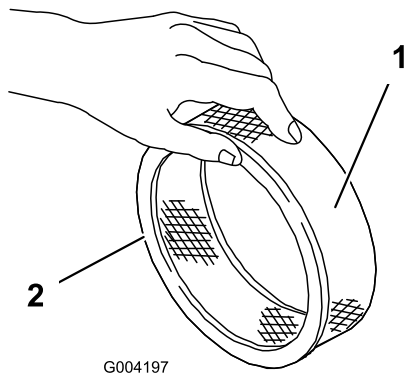

Figure 45

1. Paper element
2. Rubber seal

Important: Never clean the paper element. Replace the paper element if it is dirty or damaged (i.e., after approximately 100 operating hours).

Installing the Filters

Important: To prevent engine damage, always operate the engine with the complete foam and paper air cleaner assembly installed.

1. Carefully slide the foam pre-filter onto the paper filter (Figure 45).
2. Place the air cleaner assembly onto the air cleaner base (Figure 43).
3. Install the cover, spacer and secure it with the cover nut (Figure 43). Torque the nut to 95 inch-lb (11 N-m).
4. Install the air cleaner cover and secure with the knob (Figure 43).

Changing the Engine Oil and Filter

Service Interval: After the first 50 hours

Every 100 hours—Change the engine oil and filter.

Note: Change oil and filter more frequently when operating conditions are extremely dusty or sandy.

Oil Type: Detergent oil (API service SJ, SK, SL, SM or higher)

Crankcase Capacity: w/filter, 1.9 liters (2.0 quarts)

Viscosity: See table below

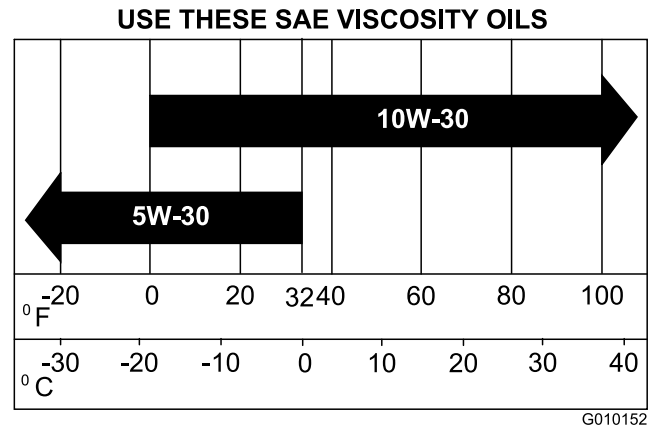

Figure 46

1. Start the engine and let it run for five minutes. This warms the oil so it drains better.
 2. Park the machine so that the drain side is slightly lower than the opposite side to ensure that the oil drains completely.
 3. Set the parking brake, stop the engine, and remove the key.
 4. Place a pan below the oil drain. Remove the oil drain plug to allow oil to drain.
 5. When the oil has drained completely, replace the plug.
- Note:** Dispose of the used oil at a certified recycling center.
6. Place a shallow pan or rag under the filter to catch oil (Figure 47).

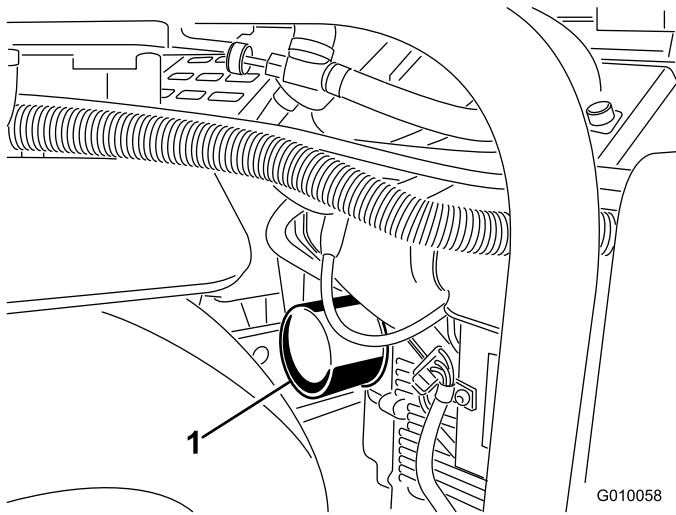

Figure 47

1. Oil filter

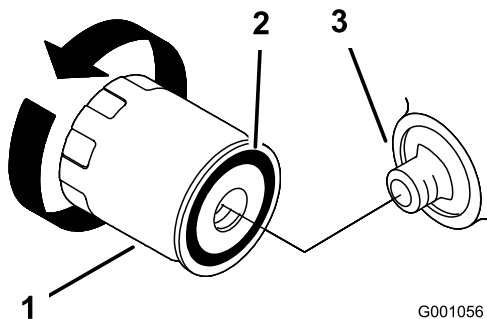

Figure 48

1. Oil filter
2. Gasket
3. Adapter

7. Remove the old filter (Figure 47 and Figure 48) and wipe the surface of the filter adapter gasket.
8. Pour new oil of the proper type through the center hole of the filter. Stop pouring when the oil reaches the bottom of the threads.
9. Allow a minute or two for the oil to be absorbed by filter material, then pour off the excess oil.
10. Apply a thin coat of new oil to the rubber gasket on the replacement filter.
11. Install the replacement oil filter to the filter adapter. Turn the oil filter clockwise until the rubber gasket contacts the filter adapter, then tighten the filter an additional 1/2 turn.
12. Remove the oil fill cap and slowly pour approximately 80% of the specified amount of oil in through the valve cover.
13. Check the oil level; refer to Checking the Engine Oil Level.
14. Slowly add additional oil to bring the level to the F (full) mark on the dipstick.

15. Replace the fill cap.

Servicing the Spark Plugs

Service Interval: Every 200 hours—Check the spark plugs.

Ensure that the air gap between the center and side electrodes is correct before installing each spark plug. Use a spark plug wrench for removing and installing the spark plugs and a gapping tool/feeler gauge to check and adjust the air gap. Install new spark plugs if necessary.

Type: Champion RC12YC or equivalent. Air Gap: 0.75 mm (0.03 inch)

Removing the Spark Plugs

1. Stop the engine, set the parking brake, and remove the key.
2. Pull the wires off of the spark plugs (Figure 49).

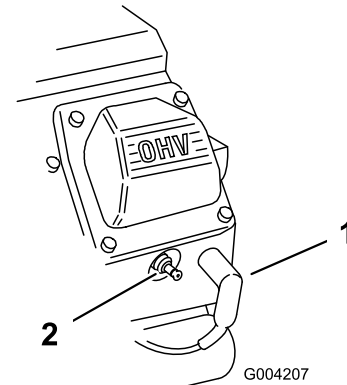

Figure 49

1. Spark plug wire
2. Spark plug

3. Clean around the spark plugs.
4. Remove both spark plugs and metal washers.

Checking the Spark Plugs

1. Look at the center of both spark plugs (Figure 50). If you see light brown or gray on the insulator, the engine is operating properly. A black coating on the insulator usually means the air cleaner is dirty.

Important: Never clean the spark plugs. Always replace the spark plugs when they have a black coating, worn electrodes, an oily film, or cracks.

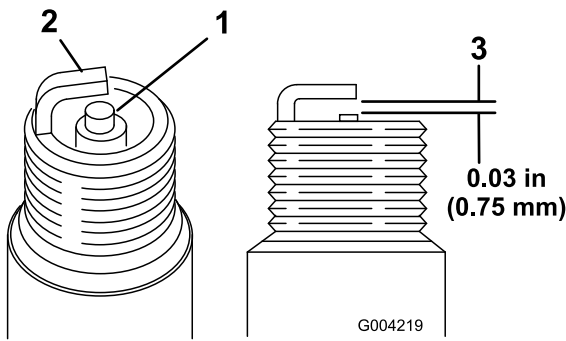

Figure 50

1. Center electrode insulator
2. Side electrode
3. Air gap (not to scale)

2. Check the gap between the center and side electrodes (Figure 50).
3. Bend the side electrode (Figure 50) if the gap is not correct.

Installing the Spark Plugs

1. Thread the spark plugs into the spark plug holes.
2. Tighten the spark plugs to 27 N-m (20 ft-lb).
3. Push the wires onto the spark plugs (Figure 49).

Fuel System Maintenance

Replacing the Fuel Filter

Service Interval: Every 100 hours/Yearly (whichever comes first)

Important: Never install a dirty filter if it is removed from the fuel line.

1. Allow the machine to cool down.
2. Close the fuel shut-off valve (Figure 51).

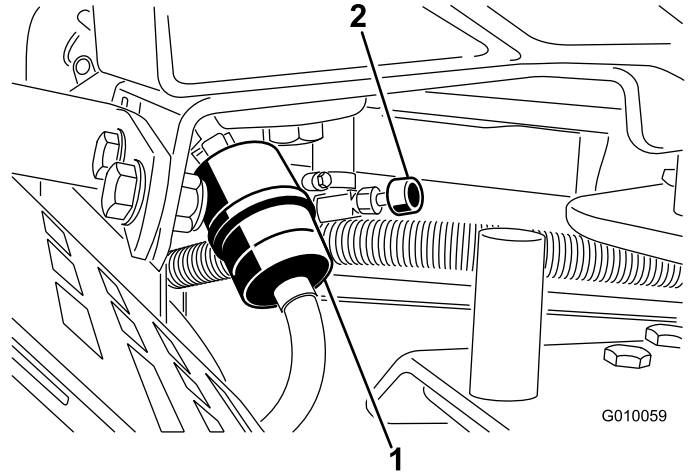

Figure 51

1. Fuel filter
2. Fuel shut-off valve

3. Squeeze the ends of the hose clamps together and slide them away from the filter (Figure 51).
4. Remove the filter from the fuel lines.
5. Install a new filter and move the hose clamps close to the filter (Figure 51).
6. Wipe up any spilled fuel.
7. Open fuel shut-off valve (Figure 51).

Draining the Fuel Tank

⚠ DANGER

In certain conditions, gasoline is extremely flammable and highly explosive. A fire or explosion from gasoline can burn you and others and can damage property.

- Drain gasoline from the fuel tank when the engine is cold. Do this outdoors in an open area. Wipe up any gasoline that spills.
- Never smoke when draining gasoline, and stay away from an open flame or where a spark may ignite the gasoline fumes.

1. Park the machine on a level surface to ensure the fuel tank drains completely. Then, set the parking brake, and turn the ignition key to off. Remove the key.
2. Close the fuel shut-off valve (Figure 51).
3. Loosen the hose clamp at the fuel filter and slide it up the fuel line away from the fuel filter (Figure 51).
4. Pull the fuel line off fuel filter (Figure 51). Open the fuel shut-off valve and allow gasoline to drain into a gas can or drain pan.

Note: Now is the best time to install a new fuel filter because the fuel tank is empty.

5. Install the fuel line onto the fuel filter. Slide the hose clamp close to the fuel filter to secure the fuel line (Figure 51).

Electrical System Maintenance

Servicing the Battery

Service Interval: Every 25 hours—Check the electrolyte level and clean the battery.

Every 25 hours—Check the battery cable connections.

WARNING

CALIFORNIA Proposition 65 Warning

Battery posts, terminals, and related accessories contain lead and lead compounds, chemicals known to the State of California to cause cancer and reproductive harm.
Wash hands after handling.

⚠ DANGER

Battery electrolyte contains sulfuric acid which is a deadly poison and causes severe burns.

- Do not drink electrolyte and avoid contact with skin, eyes, or clothing. Wear safety glasses to shield your eyes and rubber gloves to protect your hands.
- Fill the battery where clean water is always available for flushing the skin.

The battery electrolyte level must be properly maintained and the top of the battery kept clean. If the machine is stored in a location where temperatures are extremely high, the battery will run down more rapidly than if the machine is stored in a location where temperatures are cool.

Check the electrolyte level every 25 operating hours or, if machine is in storage, every 30 days.

Maintain the cell level with distilled or demineralized water. Do not fill the cells above the bottom of the split ring inside each cell.

Keep the top of the battery clean by washing it periodically with a brush dipped in ammonia or bicarbonate of soda solution. Flush the top surface with water after cleaning. Do not remove the fill caps while cleaning.

The battery cables must be tight on the terminals to provide good electrical contact.

⚠ WARNING

Incorrect battery cable routing could damage the machine and cables causing sparks. Sparks can cause the battery gasses to explode, resulting in personal injury.

- Always *disconnect* the negative (black) battery cable before disconnecting the positive (red) cable.
- Always *connect* the positive (red) battery cable before connecting the negative (black) cable.

If corrosion occurs at the terminals, disconnect the cables (negative (-) cable first) and scrape clamps and terminals separately. Reconnect the cables (positive (+) cable first) and coat the terminals with petroleum jelly.

⚠ WARNING

Battery terminals or metal tools could short against metal tractor components causing sparks. Sparks can cause the battery gasses to explode, resulting in personal injury.

- When removing or installing the battery, do not allow the battery terminals to touch any metal parts of the machine.
- Do not allow metal tools to short between the battery terminals and metal parts of the machine.

Fuses

The electrical system is protected by fuses (Figure 52). It requires no maintenance; however, if a fuse blows, check the component/circuit for a malfunction or short.

1. To replace fuses, pull out on the fuse to remove it.
2. Install a new fuse.

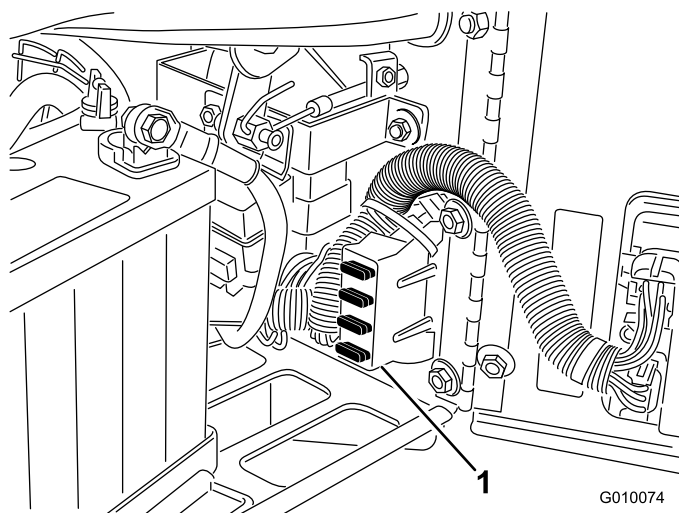

Figure 52

1. Fuse block

Drive System Maintenance

Checking the Tire Pressure

Service Interval: Every 50 hours/Monthly (whichever comes first)

Check to ensure that the air pressure in all tires is 83 kPa (12 psi). Check the tires when they are cold to get the most accurate pressure reading.

Important: Uneven tire pressure can cause uneven coring depth.

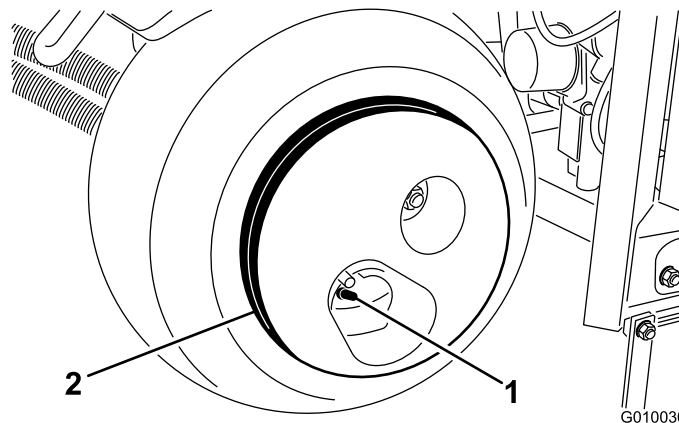

Figure 53

1. Valve stem
2. Wheel weight

⚠ CAUTION

The wheel weight is very heavy, 33 kg (73 lb). Use caution when removing it from the tire assembly.

Adjusting the Traction Drive for Neutral

The machine must not creep when traction lever is released. If it does, an adjustment is required.

1. Park the aerator on a level surface, shut the engine off, and engage the parking brake.
2. Jack up the machine so the front wheel and one rear wheel is just off the ground. Place jack stands under machine. Refer to Jacking Instructions.
3. Loosen the locknut on the traction adjustment cam (Figure 54).

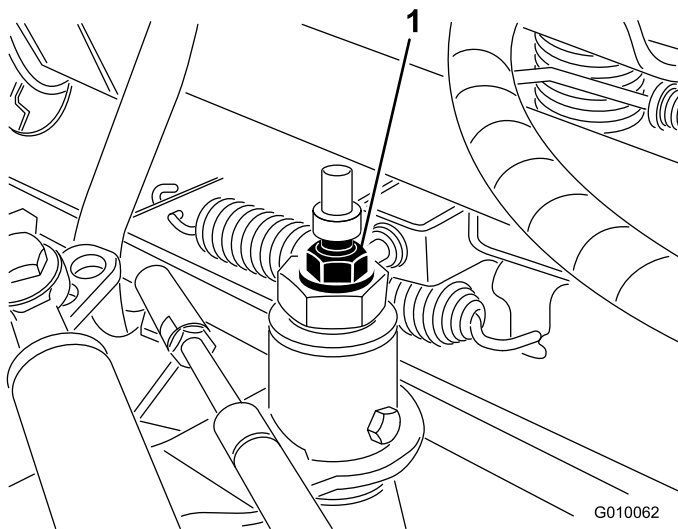

Figure 54

1. Traction adjustment cam

4. Start engine and release the parking brake.

⚠ WARNING

The engine must be running so the final adjustment of the traction adjustment cam can be performed. This could cause personal injury.

Keep hands, feet, face, and other body parts away from the muffler, other hot parts of the engine, and any rotating parts.

5. Rotate the cam hex in either direction until the wheels do not rotate.
6. Tighten the locknut securing the adjustment.
7. Stop the engine.
8. Remove the jack stands and lower the machine to the ground.
9. Test the machine to make sure it does not creep.

Belt Maintenance

Adjusting the Pump Belt

Service Interval: After the first 8 hours

1. Unlatch and remove the belt cover (Figure 55).

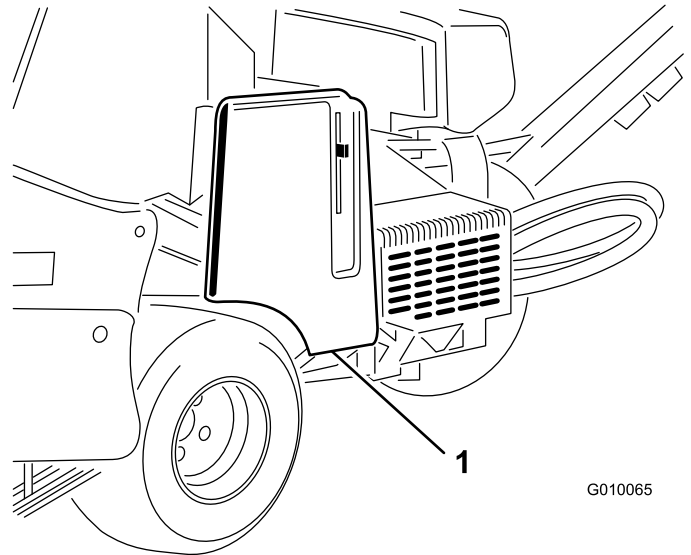

Figure 55

1. Belt cover

2. Remove the 2 pump shield mounting nuts and remove the shield (Figure 56).

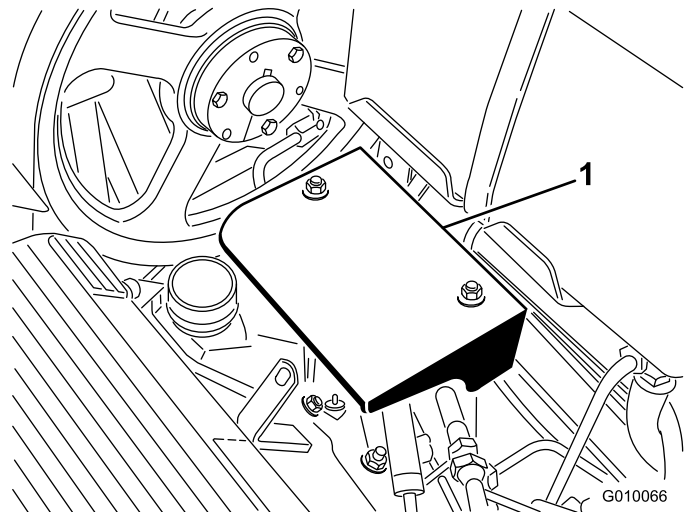

Figure 56

1. Pump shield

3. Loosen the pump belt idler bolt just enough to allow movement within its adjustment slot (Figure 57).

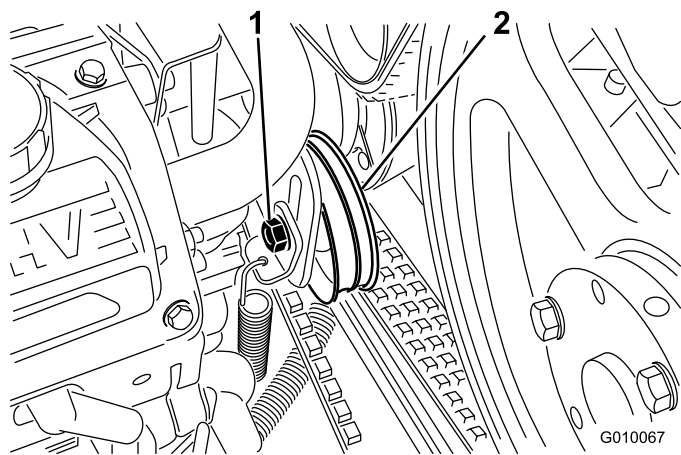

Figure 57

1. Idler bolt
2. Idler pulley

4. Tap the top of the idler pulley and allow its tensioning spring to adjust the belt tension.

Note: Do not apply more belt tension than the tensioning spring allows as damage to the components may result.

5. Secure the belt idler bolt.
6. Install the pump shield and belt cover.

Inspecting the Belts

Service Interval: Yearly

The drive belts on the machine have been designed to be very durable. However, the normal exposure to UV radiation, ozone, or incidental exposure to chemicals can deteriorate the rubber over time and lead to premature wear or material loss (i.e., chunking).

Inspect the belts yearly for signs of wear, excessive cushion cracks, or large embedded debris. Replace them when needed. A complete belt service kit is available from your Authorized Toro Distributor.

Controls System Maintenance

Resetting the Ground Following System

If the True Core ground following system requires service of any kind (with the exception of turf guard replacement) or if the tine holders are contacting the turf guards when set in the deepest setting, the depth adjustment tie rod may need to be reset.

1. Rotate the LH turf guard mounting bracket (Figure 58) up until a locking pin (5/16 drill rod or bolt) can be inserted between the bracket and the depth setting tube welded to the frame.

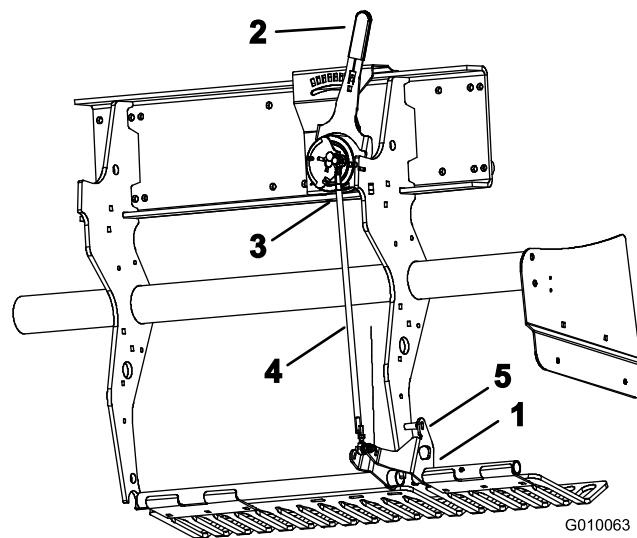

Figure 58

1. Turf guard mounting bracket
2. Tine depth lever
3. Out board ball switch
4. Depth adjustment tie rod
5. Locking pin

2. Move the tine depth lever (Figure 58) to the H setting (deepest).
3. Disconnect the outboard ball switch (Figure 58) from the wire harness (Head-Low switch).
4. Loosen the jam nuts (LH and RH) on the depth adjustment tie rod (Figure 58).
5. Use a multi-meter to determine the electrical closure of the ball switch.
6. Rotate the tie rod until the ball switch just closes or makes contact.
7. Secure the LH & RH jam nuts on the tie rod.
8. Connect the ball switch to the wire harness.
9. Remove the pin from the turf guard bracket and depth setting tube.

Hydraulic System Maintenance

⚠ WARNING

Hydraulic fluid escaping under pressure can penetrate skin and cause injury. Fluid injected into the skin must be surgically removed within a few hours by a doctor familiar with this form of injury or gangrene may result.

- If hydraulic fluid is injected into the skin it must be surgically removed within a few hours by a doctor familiar with this type of injury. Gangrene may result if this is not done.
- Keep your body and hands away from pin hole leaks or nozzles that eject high pressure hydraulic fluid.
- Use cardboard or paper to find hydraulic leaks, never use your hands.
- Safely relieve all pressure in the hydraulic system before performing any work on it.
- Make sure all hydraulic fluid hoses and lines are in good condition and all hydraulic connections and fittings are tight before applying pressure to hydraulic system.

Checking the Hydraulic Lines

Service Interval: Before each use or daily

Before each use, check the hydraulic lines and hoses for leaks, loose fittings, kinked lines, loose mounting supports, wear, weather and chemical deterioration. Make necessary repairs before operating.

Note: Keep the areas around the hydraulic system clean from debris build up.

Changing the Hydraulic Fluid and Filters

Service Interval: After the first 8 hours

Every 200 hours

Important: Do not substitute automotive oil filters or severe hydraulic system damage may result.

Note: Removing the return filter will drain the entire oil reservoir.

1. Set the parking brake, stop the engine, remove the key, and wait for all moving parts to stop before leaving the operating position.
2. Place a drain pan under the filters, remove the old filters, and wipe the filter adapter gasket surface clean (Figure 59).

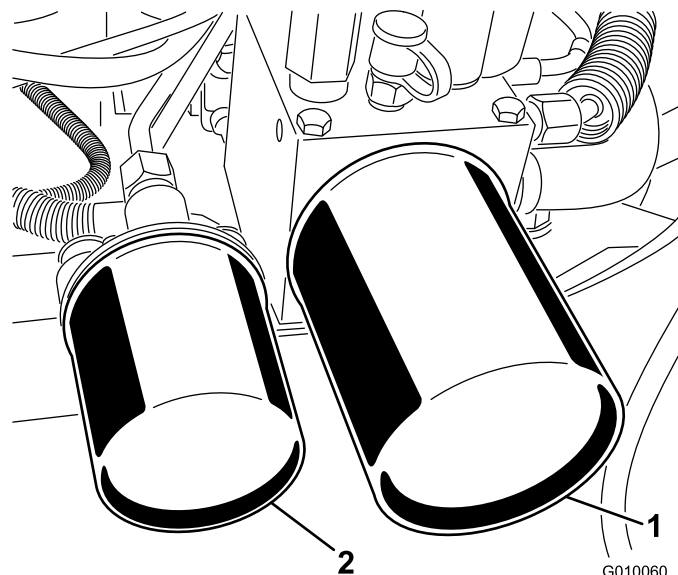

Figure 59

1. Hydraulic return filter
2. Hydraulic charge filter

3. Apply a thin coat of hydraulic fluid to the rubber gasket on the replacement filters.
4. Install the replacement hydraulic filters onto the filter adapters. Turn the each filter clockwise until the rubber gasket contacts the filter adapter, then tighten each an additional 1/2 turn.
5. Add fluid to the Full mark on the dipstick, refer to Checking the Hydraulic Fluid.
6. Start the engine and let it run for about two minutes to purge air from the system. Stop the engine and check for leaks.
7. Recheck the level while the fluid is warm. Add fluid to raise the level to the Full mark on the dipstick, if required. Do not overfill.

Hydraulic System Test Ports

The test ports are used to test the pressure in the hydraulic circuits. Contact your local Toro distributor for assistance.

- Test Port G 2 (Figure 60) is used to assist in trouble shooting the traction charge circuit.

Aerator Maintenance

Checking the Fastener Torque

Service Interval: After the first 8 hours

Check the coring head fasteners, tiller handle fasteners and wheel lug nuts to ensure proper torque is maintained. Fastener torque requirements are listed on the reference service decal located on the coring head.

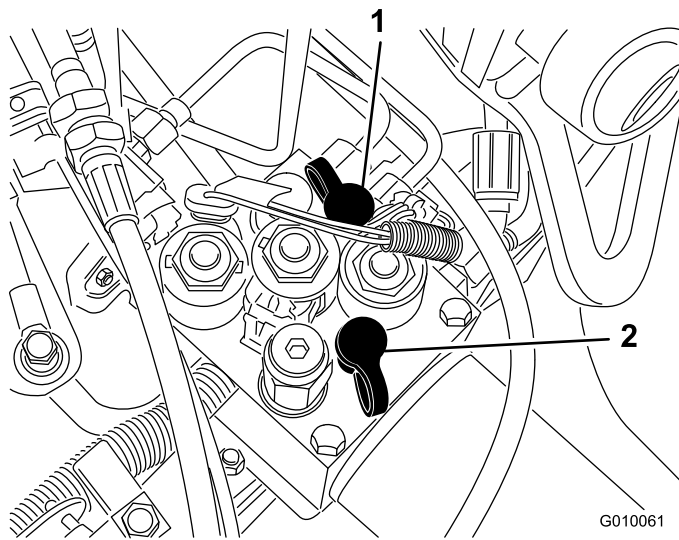

Figure 60

1. Test port G2

2. Test port G1

- Test Port G 1 (Figure 60) is used to assist in troubleshooting the lift circuit pressure.

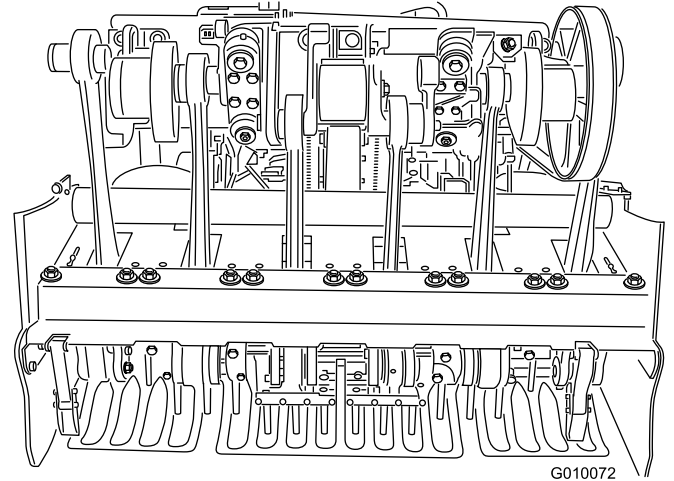

Figure 61

Adjusting the Side Shields

The coring head side shields should be adjusted so the bottom rides between 25 to 38 mm (1 to 1.5 inches) from the turf while aerating.

1. Loosen the bolts and nuts securing the side shield to frame (Figure 62).

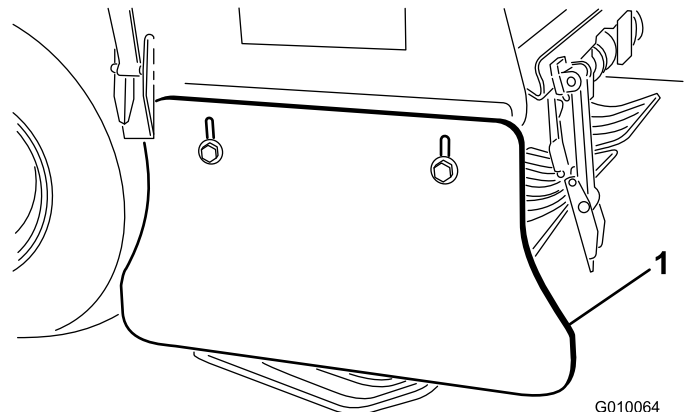

Figure 62

1. Side shield

2. Adjust the shield up or down and tighten the nuts.

Replacing the Turf Guards

All turf guards should be replaced if broken or worn to less than 6 mm (1/4 inch) thickness. Broken turf guards can catch and tear turf creating undesirable damage.

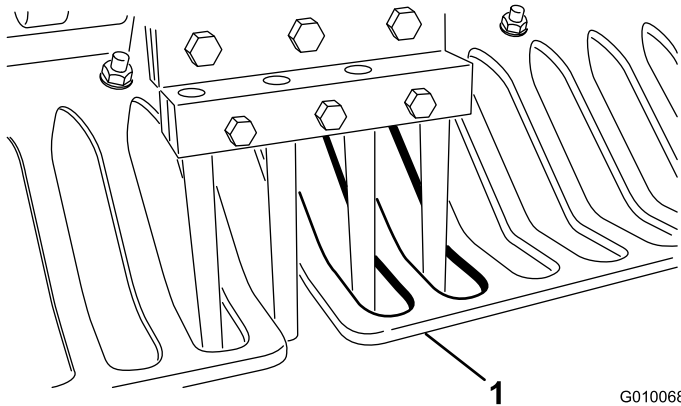

Figure 63

G010068

1. Turf guard

Thin turf guards can cause the True Core ground following system to be off from the desired depth setting due to both wear and the loss of stiffness.

Adjusting Hole Spacing

The hole spacing of the aerator is determined by the ground speed the traction system is set to maintain. The hole spacing is set to within 3 mm (1/8 inch) of the nominal setting at the factory.

In the event the hole spacing is off from the nominal setting more than desired, proceed as follows:

1. Unlatch and remove the belt cover (Figure 55).
2. Remove the 2 pump shield mounting nuts and remove the shield (Figure 56).
3. In an open space that is free to aerate (i.e. sample plot), set the hole spacing lever to the desired hole spacing and make an aeration pass of at least 4.5 m (15 feet).
4. Measure the distance between several holes and divide by the number of holes measured to get your average hole spacing.

Example: Nominal Hole Spacing Setting of 2 inches:

21.2 divided by 10 is 2.12, hole spacing is long by .12 inch from nominal (Figure 64).

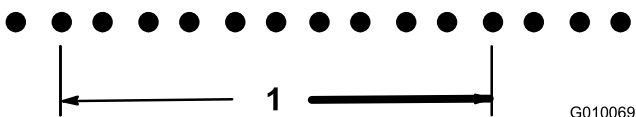

Figure 64

G010069

1. 21.2 inches (10 holes)

18.8 divided by 10 is 1.88, hole spacing is short by .12 inch from nominal (Figure 65).

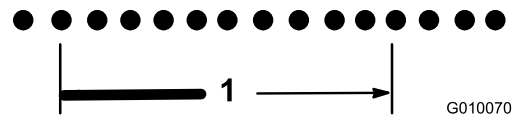

Figure 65

G010070

1. 18.8 inches (10 holes)

5. If an adjustment is needed, turn the pump stop bolt (Figure 66) closer to the stop plate to decrease hole spacing or turn the stop bolt away from the stop plate to increase hole spacing.

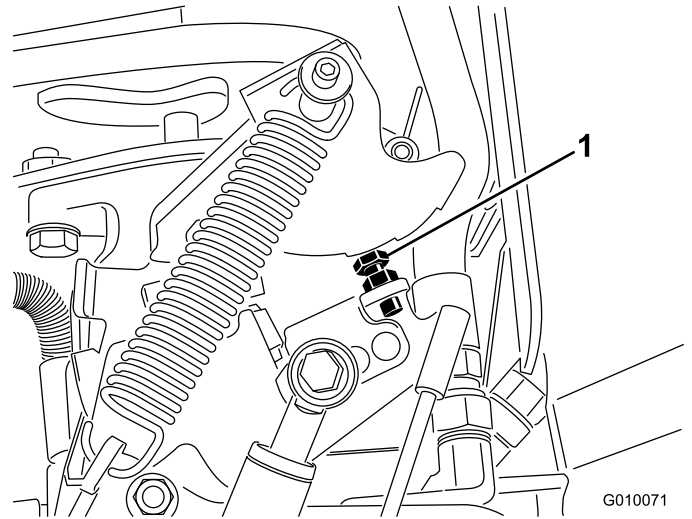

Figure 66

G010071

1. Pump stop bolt

6. Repeat steps 3 through 5 until spacing is at the nominal setting.

Note: One complete turn of the stop bolt adjusts the hole spacing approximately 16 mm (5/8 inch).

Coring Head Timing

The coring head timing marks are easily identified by the marks in the casting.

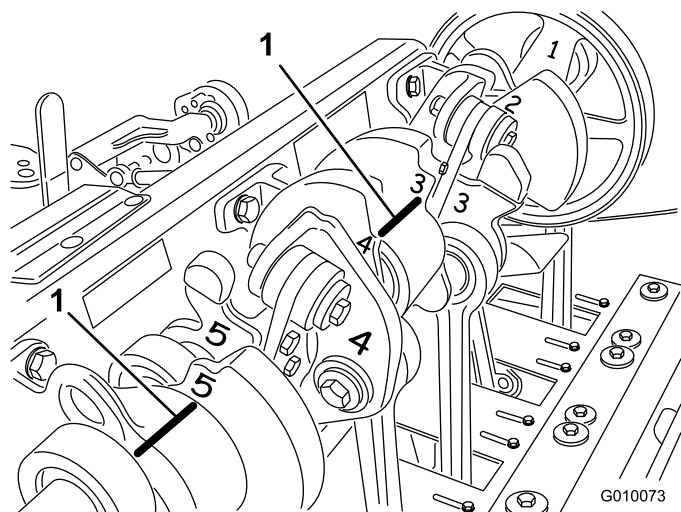

Figure 67

1. Timing marks

Storage

1. Set the parking brake and turn the ignition key to off. Remove spark plug wire. Remove the key.
2. Remove grass, dirt, and grime from the external parts of the entire machine, especially the engine and hydraulic system. Clean dirt and chaff from the outside of the engine's cylinder head fins and blower housing.
3. Service the air cleaner; refer to Servicing the Air Cleaner.
4. Change the crankcase oil; refer to Changing the Engine Oil and Filter.
5. Change the hydraulic filters and Fluid, refer to Changing the Hydraulic Fluid and Filters.
6. Check the tire pressure; refer to Checking the Tire Pressure.
7. Check the condition of the tines.
8. If you will be storing the machine for more than 30 days, prepare it as follows:
 - A. Remove the battery terminals from the battery posts and remove the battery from the machine.
 - B. Clean the battery, terminals, and posts with a wire brush and baking soda solution.
 - C. Coat the cable terminals and battery posts with Grafo 112X skin-over grease (Toro Part No. 505-47) or petroleum jelly to prevent corrosion.
 - D. Slowly recharge the battery every 60 days for 24 hours to prevent lead sulfation of the battery. To prevent the battery from freezing, make sure it is fully charged. The specific gravity of a fully charged battery is 1.265 to 1.299.

⚠ WARNING

Charging the battery produces gasses that can explode.

Never smoke near the battery and keep sparks and flames away from it.

- E. Either store the battery on the shelf or on the machine. Leave the cables disconnected if it is stored on the machine. Store it in a cool atmosphere to avoid quick deterioration of the charge in the battery.
- F. Add a petroleum based stabilizer/conditioner to fuel in the tank. Follow mixing instructions from stabilizer manufacture. **Do not use an alcohol based stabilizer (ethanol or methanol).**

Note: A fuel stabilizer/conditioner is most effective when mixed with fresh gasoline and used at all times.
- G. Run engine to distribute conditioned fuel through the fuel system (5 minutes).

- H. Stop engine, allow to cool and drain the fuel tank; refer to Draining the Fuel Tank.
- I. Restart engine and run it until it stops.
- J. Choke the engine. Start and run engine until it will not start.
- K. Dispose of fuel properly. Recycle as per local codes.

Important: Do not store stabilizer/conditioned gasoline over 90 days.

- 9. Remove the spark plugs and check the condition; refer to Servicing the Spark Plugs. With the spark plugs removed from the engine, pour two tablespoons of engine oil into each spark plug hole. Now use the starter to crank the engine and distribute the oil inside the cylinders. Install the spark plugs. Do not install the wires on the spark plugs.
- 10. Check and tighten all bolts, nuts, and screws. Repair or replace any part that is damaged or defective.
- 11. Wash and dry entire unit. Remove tines, clean and oil. Spray light oil mist on coring head bearings (crank & damper links).

Important: You can wash the machine with mild detergent and water. Do not pressure wash the machine. Avoid excessive use of water, especially near the control panel, engine, hydraulic pumps and motors.

Note: Run the machine with the engine at high idle for 2 to 5 minutes after washing.

- 12. Paint all scratched or bare metal surfaces. Paint is available from your Authorized Service Distributor.
- 13. Secure service latch if the aerator is to be stored for more than a couple days.
- 14. Store the machine in a clean, dry garage or storage area. Remove the key from the ignition switch and keep it out of reach of children or other unauthorized users.
- 15. Cover the machine to protect it and keep it clean.

Troubleshooting

Problem	Possible Cause	Corrective Action
Starter does not crank	<ol style="list-style-type: none"> 1. Traction lever not in neutral position. 2. The battery is dead. 3. Electrical connections are corroded or loose. 4. Neutral switch incorrectly adjusted. 5. Relay or switch is defective. 	<ol style="list-style-type: none"> 1. Move traction lever to neutral position 2. Charge the battery. 3. Check electrical connections for good contact. 4. Adjust neutral switch. 5. Contact your Authorized Service Distributor.
The engine will not start, starts hard, or fails to keep running.	<ol style="list-style-type: none"> 1. The fuel tank is empty 2. The choke is not on. 3. The air cleaner is dirty. 4. The spark plug wires are loose or disconnected. 5. The spark plugs are pitted, fouled, or the gap is incorrect. 6. There is dirt in the fuel filter. 7. There is dirt, water, or stale fuel in the fuel system. 	<ol style="list-style-type: none"> 1. Fill the fuel tank with gasoline 2. Move the choke lever fully forward. 3. Clean or replace air cleaner element. 4. Install wires on spark plugs. 5. Install new, correctly gapped spark plugs. 6. Replace fuel filter. 7. Contact your Authorized Service Distributor.
The engine loses power.	<ol style="list-style-type: none"> 1. The engine load is excessive. 2. The air cleaner is dirty. 3. The engine oil level is low. 4. The cooling fins and air passages under engine blower housing are plugged. 5. The spark plugs are pitted, fouled, or the gap is incorrect. 6. There is dirt in the fuel filter. 7. There is dirt, water, or stale fuel in the fuel system. 	<ol style="list-style-type: none"> 1. Reduce ground speed. 2. Clean the air cleaner element. 3. Add oil to the crankcase. 4. Remove any debris from the cooling fins and air passages. 5. Install new, correctly gapped spark plugs. 6. Replace fuel filter. 7. Contact your Authorized Service Distributor.
The engine overheats.	<ol style="list-style-type: none"> 1. The engine load is excessive. 2. The engine oil level is low. 3. The cooling fins and air passages under engine blower housing are plugged. 	<ol style="list-style-type: none"> 1. Reduce ground speed. 2. Add oil to the crankcase. 3. Remove any debris from the cooling fins and air passages.
Abnormal vibration.	<ol style="list-style-type: none"> 1. The engine mounting bolts are loose. 2. The jackshaft or coring head bearings are worn. 3. The jackshaft or coring head components are loose or worn. 	<ol style="list-style-type: none"> 1. Tighten the engine mounting bolts. 2. Replace the bearings. 3. Tighten or replace components.
The aerator does not drive.	<ol style="list-style-type: none"> 1. The parking brake is on. 2. The hydraulic fluid level is low. 3. The tow valve is open. 4. The hydraulic system is damaged. 	<ol style="list-style-type: none"> 1. Release the parking brake. 2. Add hydraulic fluid. 3. Close the tow valve. 4. Contact your Authorized Service Distributor.
The coring head does not drive.	<ol style="list-style-type: none"> 1. The hydraulic fluid level is low. 2. The tow valve is open. 3. A belt is worn or loose. 4. The clutch is worn. 5. A switch or relay is worn. 6. The hydraulic system is damaged. 	<ol style="list-style-type: none"> 1. Add hydraulic fluid. 2. Close the tow valve. 3. Adjust or replace the belts. 4. Replace the clutch. 5. Replace the switch or relay. 6. Contact your Authorized Service Distributor.

Problem	Possible Cause	Corrective Action
The head bounces while aerating.	<ol style="list-style-type: none"> 1. The ground is too hard. 2. Relief setting/Restriction orifice. 	<ol style="list-style-type: none"> 1. Refer to Operating Tips. 2. Dynamic response of lift system. Adjust the system pressures. Refer to the Service Manual.
The turf is tufting/tearing on entrance and exit.	<ol style="list-style-type: none"> 1. The switch bundle needs adjustment. 2. The head lowers too slowly. 	<ol style="list-style-type: none"> 1. Adjust the switch. Refer to the Service Manual. 2. Check the function of the SVQ solenoid.
Quad (or mini) tine hole spacing.	<ol style="list-style-type: none"> 1. The holes are not evenly spaced. 	<ol style="list-style-type: none"> 1. Check the spacing. Refer to Operating Tips.
Hole tufting with side eject tines.	<ol style="list-style-type: none"> 1. The ejection window is catching on exit. 	<ol style="list-style-type: none"> 1. Rotate the tine 45–90 degrees so it ejects out the side. If that doesn't work, try a hollow tine.
The turf is lifting/tearing while aerating.	<ol style="list-style-type: none"> 1. Check the coring head attitude. 2. Improper tine selection 3. Excessive depth 4. The hole spacing is too close. 5. The turf conditions (i.e. root structure) are insufficient to resist damage. 	<ol style="list-style-type: none"> 1. Refer to the Service Manual for specification. 2. Reduce the tine diameter, reduce the number of tines per head, or increase the hole spacing. 3. Reduce the depth. 4. Increase the hole spacing. 5. Alter the aeration methods or timing.
The front of the hole is dimpled or pushed.	<ol style="list-style-type: none"> 1. Roto-Link is in the soft position. 	<ol style="list-style-type: none"> 1. Refer to Operating Tips.

Notes:

Notes:

Notes:



Toro Commercial Aerator Products Warranty

A two-Year Limited Warranty

Conditions and Products Covered

The Toro Company and its affiliate, Toro Warranty Company, pursuant to an agreement between them, jointly warrant your Toro Hydroject or ProCore Aerator ("Product") to be free from defects in materials or workmanship for two years or 500 operational hours*, whichever occurs first. This warranty is applicable to all products with the exception of Aerators (refer to separate warranty statements for these products).

Where a warrantable condition exists, we will repair the Product at no cost to you including diagnostics, labor, parts, and transportation. This warranty begins on the date the Product is delivered to the original retail purchaser.

* Product equipped with an hour meter.

Instructions for Obtaining Warranty Service

You are responsible for notifying the Commercial Products Distributor or Authorized Commercial Products Dealer from whom you purchased the Product as soon as you believe a warrantable condition exists. If you need help locating a Commercial Products Distributor or Authorized Dealer, or if you have questions regarding your warranty rights or responsibilities, you may contact us at:

Commercial Products Service Department
Toro Warranty Company
8111 Lyndale Avenue South
Bloomington, MN 55420-1196
952-888-8801 or 800-952-2740
E-mail: commercial.warranty@toro.com

Owner Responsibilities

As the Product owner, you are responsible for required maintenance and adjustments stated in your *Operator's Manual*. Failure to perform required maintenance and adjustments can be grounds for disallowing a warranty claim.

Items and Conditions Not Covered

Not all product failures or malfunctions that occur during the warranty period are defects in materials or workmanship. This warranty does not cover the following:

- Product failures which result from the use of non-Toro replacement parts, or from installation and use of add-on, or modified non-Toro branded accessories and products. A separate warranty may be provided by the manufacturer of these items.
- Product failures which result from failure to perform recommended maintenance and/or adjustments. Failure to properly maintain your Toro product per the recommended maintenance listed in the *Operator's Manual* can result in claims for warranty being denied.
- Product failures which result from operating the Product in an abusive, negligent or reckless manner.
- Parts subject to consumption through use unless found to be defective. Examples of parts which are consumed, or used up, during normal Product operation include, but are not limited to, brakes pads and linings, clutch linings, blades, reels, bed knives, tines, spark plugs, castor wheels, tires, filters, belts, and certain sprayer components such as diaphragms, nozzles, and check valves, etc.
- Failures caused by outside influence. Items considered to be outside influence include, but are not limited to, weather, storage practices,

contamination, use of unapproved coolants, lubricants, additives, fertilizers, water, or chemicals, etc.

- Normal noise, vibration, wear and tear, and deterioration.
- Normal "wear and tear" includes, but is not limited to, damage to seats due to wear or abrasion, worn painted surfaces, scratched decals or windows, etc.

Parts

Parts scheduled for replacement as required maintenance are warranted for the period of time up to the scheduled replacement time for that part. Parts replaced under this warranty are covered for the duration of the original product warranty and become the property of Toro. Toro will make the final decision whether to repair any existing part or assembly or replace it. Toro may use remanufactured parts for warranty repairs.

Maintenance is at Owner's Expense

Engine tune-up, lubrication cleaning and polishing, replacement of Items and Conditions Not Covered, filters, coolant, and completing recommended maintenance are some of the normal services Toro products require that are at the owner's expense.

General Conditions

Repair by an Authorized Toro Distributor or Dealer is your sole remedy under this warranty.

Neither The Toro Company nor Toro Warranty Company is liable for indirect, incidental or consequential damages in connection with the use of the Toro Products covered by this warranty, including any cost or expense of providing substitute equipment or service during reasonable periods of malfunction or non-use pending completion of repairs under this warranty. Except for the Emissions warranty referenced below, if applicable, there is no other express warranty.

All implied warranties of merchantability and fitness for use are limited to the duration of this express warranty. Some states do not allow exclusions of incidental or consequential damages, or limitations on how long an implied warranty lasts, so the above exclusions and limitations may not apply to you.

This warranty gives you specific legal rights, and you may also have other rights which vary from state to state.

Note regarding engine warranty:

The Emissions Control System on your Product may be covered by a separate warranty meeting requirements established by the U.S. Environmental Protection Agency (EPA) and/or the California Air Resources Board (CARB). The hour limitations set forth above do not apply to the Emissions Control System Warranty. Refer to the Engine Emission Control Warranty Statement printed in your *Operator's Manual* or contained in the engine manufacturer's documentation for details

Countries Other than the United States or Canada

Customers who have purchased Toro products exported from the United States or Canada should contact their Toro Distributor (Dealer) to obtain guarantee policies for your country, province, or state. If for any reason you are dissatisfied with your Distributor's service or have difficulty obtaining guarantee information, contact the Toro importer. If all other remedies fail, you may contact us at Toro Warranty Company.