



Count on it.

Operator's Manual

**Commercial Walk-Behind Mower
16HP, T-Bar, Gear Drive with 91cm TURBO
FORCE® Cutting Unit**

Model No. 30070—Serial No. 314000001 and Up

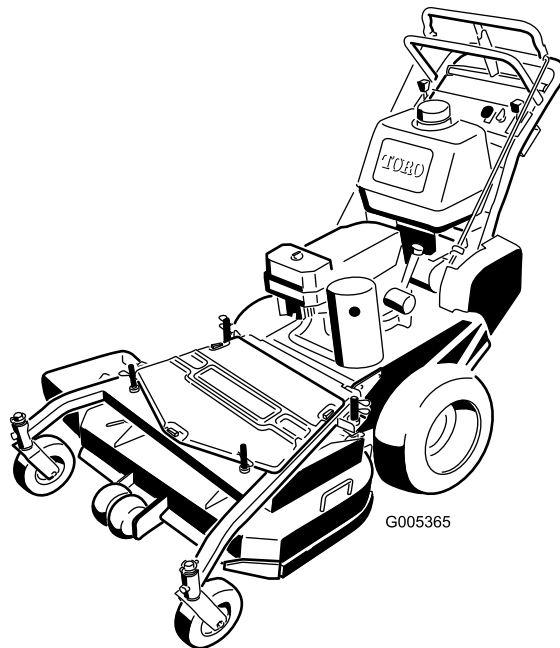

G005365



This product complies with all relevant European directives, for details please see the separate product specific Declaration of Conformity (DOC) sheet.

This manual identifies potential hazards and has safety messages identified by the safety alert symbol (Figure 2), which signals a hazard that may cause serious injury or death if you do not follow the recommended precautions.

Introduction

This rotary-blade, lawn mower is intended to be used by residential homeowners or professional, hired operators. It is designed primarily for cutting grass on well-maintained lawns on residential or commercial properties. It is not designed for cutting brush or for agricultural uses.

Read this information carefully to learn how to operate and maintain your product properly and to avoid injury and product damage. You are responsible for operating the product properly and safely.

You may contact Toro directly at www.Toro.com for product and accessory information, help finding a dealer, or to register your product.

Whenever you need service, genuine Toro parts, or additional information, contact an Authorized Service Dealer or Toro Customer Service and have the model and serial numbers of your product ready. Figure 1 identifies the location of the model and serial numbers on the product. Write the numbers in the space provided.

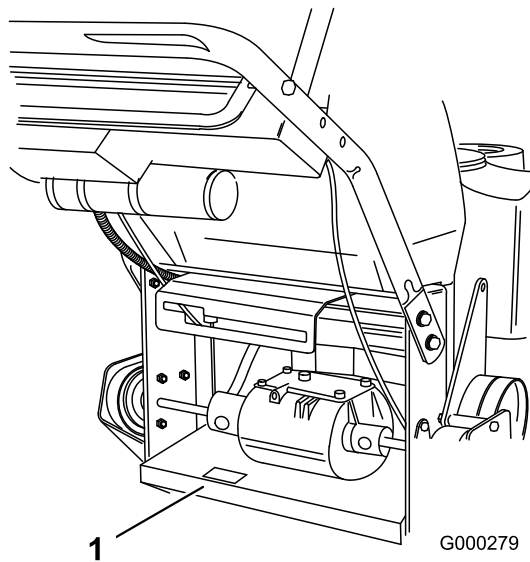

Figure 1

1. Model and serial number location

Model No. _____
Serial No. _____



Figure 2

1. Safety alert symbol

This manual uses 2 other words to highlight information. **Important** calls attention to special mechanical information and **Note** emphasizes general information worthy of special attention.

Contents

Introduction	2	Cooling System Maintenance	31
Safety	4	Cleaning the Air Intake Screen.....	31
General Lawn Mower Safety	4	Brake Maintenance	31
Toro Mower Safety	5	Servicing the Brakes.....	31
Sound Pressure	5	Belt Maintenance	32
Sound Power	6	Checking the Belts.....	32
Vibration Level	6	Replacing the Traction Drive Belt	32
Slope Indicator	7	Replacing the Transmission Belt	32
Safety and Instructional Decals	8	Replacing the Mower Belt.....	33
Product Overview	11	Replacing the PTO Drive Belt	33
Controls	11	Adjusting the PTO Drive Belt Idler Spring	
Specifications	12	Anchor.....	34
Attachments/Accessories.....	12	Mower Deck Maintenance.....	35
Operation	12	Servicing the Cutting Blades.....	35
Adding Fuel.....	12	Correcting the Mower Quality of Cut	36
Checking the Engine Oil Level	13	Frame Set Up.....	36
Think Safety First.....	13	Checking the Mower Deck Front-to-Rear	
Using the Parking Brake	14	Pitch	39
Starting and Stopping the Engine.....	14	Changing the Mower Deck Front-to-Rear	
Operating the Mower Power Take Off		Pitch	39
(PTO)	14	Checking the Mower Deck Side-to-Side	
The Safety Interlock System.....	15	Height.....	39
Driving Forward or Backward	15	Changing the Mower Deck Side-to-Side	
Using the Lower Control Bar	16	Height.....	39
Stopping the Machine	16	Matching Height of Cut.....	39
Transporting Machines.....	17	Replacing the Grass Deflector.....	40
Side Discharging or Mulching the Grass.....	17	Storage	41
Adjusting the Height-of-Cut	17	Cleaning and Storage	41
Adjusting the Anti-Scalp Rollers	18	Troubleshooting	42
Adjusting the Handle Height.....	18	Schematics	44
Adjusting the Flow Baffle	19		
Positioning the Flow Baffle.....	19		
Using the Mid-Size Weight.....	20		
Maintenance	21		
Recommended Maintenance Schedule(s)	21		
Lubrication	21		
How to Grease.....	21		
Lubricating the Caster and Wheel Bearings.....	21		
Greasing the Transmission Couplers	22		
Greasing the PTO Drive Belt Idler and Mower			
Deck Belt Idler.....	22		
Engine Maintenance	23		
Servicing the Air Cleaner	23		
Servicing the Engine Oil.....	23		
Servicing the Spark Plugs.....	25		
Fuel System Maintenance	26		
Draining the Fuel Tank	26		
Replacing the Fuel Filter.....	27		
Electrical System Maintenance	27		
Servicing the Fuse	27		
Drive System Maintenance	28		
Adjusting the Control Bar.....	28		
Checking the Tire Pressure	28		
Replacing the Caster Wheel Fork Bushings.....	29		
Servicing the Caster Wheel and Bearings	29		
Adjusting the Electric Clutch.....	30		

Safety

Improperly using or maintaining this mower can result in injury. To reduce the potential for injury, comply with these safety instructions.

Toro designed and tested this mower for reasonably safe service; however, failure to comply with the following instructions may result in personal injury.

To ensure maximum safety, best performance, and to gain knowledge of the product, it is essential that you and any other operator of the mower read and understand the contents of this manual before the engine is ever started. Pay particular attention to the safety alert symbol (Figure 2) which means Caution, Warning, or Danger—“personal safety instruction.” Read and understand the instruction because it has to do with safety. Failure to comply with the instruction may result in personal injury.

General Lawn Mower Safety

The following instructions have been adapted from the ISO standard 5395.

This cutting machine is capable of amputating hands and feet and throwing objects. Failure to observe the following safety instructions could result in serious injury or death.

Training

- Read the instructions carefully. Be familiar with the controls and the proper use of the equipment.
- Never allow children or people unfamiliar with these instructions to use the mower. Local regulations can restrict the age of the operator.
- Keep in mind that the operator or user is responsible for accidents or hazards occurring to other people or their property.
- Understand explanations for all pictograms used on the mower or in the instructions.

Gasoline

WARNING-Gasoline is highly flammable. Take the following precautions.

- Store fuel in containers specifically designed for this purpose.
- Refuel outdoors only and do not smoke while refueling.
- Add fuel before starting the engine. Never remove the cap of the fuel tank or add gasoline while the engine is running or when the engine is hot.
- If gasoline is spilled, do not attempt to start the engine but move the mower away from the area of spillage and avoid creating any source of ignition until gasoline vapors have dissipated.
- Replace all fuel tank and container caps securely.

Preparation

- While mowing, always wear substantial footwear and long trousers. Do not operate the equipment when barefoot or wearing open sandals.
- Thoroughly inspect the area where the equipment is to be used and remove all stones, sticks, wires, bones and other foreign objects.
- Before using, always visually inspect to see that guards, and safety devices, such as deflectors and/or grass catchers, are in place and working correctly.
- Before using, always visually inspect to see that the blades, blade bolts and cutter assembly are not worn or damaged. Replace worn or damaged blades and bolts in sets to preserve balance.

Starting

- Disengage all blade and drive clutches and shift into neutral before starting the engine.
- Do not tilt mower when starting the engine or switching on the motor, unless the mower has to be tilted for starting. In this case, do not tilt it more than absolutely necessary and lift only the part, which is away from the operator.
- Start the engine or switch on the motor carefully according to instructions and with feet well away from the blade(s) and not in front of the discharge chute.

Operation

- Never mow while people, especially children, or pets are nearby.
- Mow only in daylight or in good artificial light.
- Avoid operating the lawn mower in wet grass, where feasible.
- Stay alert for holes in the terrain and other hidden hazards.
- Never direct discharge of material towards bystanders.
- Do not put hands or feet near or under rotating parts. Keep clear of the discharge opening at all times.
- Never pick up or carry a lawn mower while the engine is running.
- Use extreme caution when reversing or pulling a pedestrian controlled lawn mower towards you.
- Walk, never run.
- Slopes:
 - Do not mow excessively steep slopes.
 - Exercise extreme caution when on slopes.
 - Mow across the face of slopes, never up and down and exercise extreme caution when changing direction on slopes.
 - Always be sure of your footing on slopes.

- Use low throttle settings when engaging the traction-clutch, especially in high gears. Reduce speed on slopes and in sharp turns to prevent overturning or loss of control.
- Stop the blade if the lawn mower has to be tilted for transportation when crossing surfaces other than grass and when transporting the lawn mower to and from the area to be mowed.
- Do not operate the engine in a confined space where dangerous carbon monoxide fumes can collect.
- Stop the engine
 - whenever you leave the lawn mower.
 - before refueling.
 - before removing the grass catcher.
 - before making height adjustment unless adjustment can be made from the operator's position.
- Stop the engine and disconnect the spark-plug wire or turn off and remove the key.
 - before clearing blockages or unclogging chute.
 - before checking, cleaning or working on the lawn mower.
 - after striking a foreign object, inspect the lawn mower for damage and make repairs before restarting and operating the lawn mower.
 - if lawn mower starts to vibrate abnormally (check immediately).
- Use care when using sulkies, and
 - use only approved drawbar hitch points.
 - limit loads to those you can safely control.
 - do not turn sharply: use care when reversing.
 - do not carry passengers.
- Watch out for traffic when crossing or near roadways.
- Before leaving the operator's position
 - disengage the power take-off and lower the attachments.
 - change into neutral and set the parking brake.
 - stop the engine and remove the key.
- Check grass catcher components and the discharge guard frequently and replace with manufacturer's recommended parts, when necessary.
- Replace worn or damaged parts for safety.
- Replace faulty silencers.
- If the fuel tank has to be drained, do this out-doors.
- Do not change the engine governor settings or overspeed the engine. Operating an engine at excessive speed can increase the hazard of personal injury.
- On multibladed lawn mowers, take care as rotating one blade may cause others to rotate.
- Be careful during adjustment of the lawn mower to prevent entrapment of the fingers between moving blades and fixed parts of the lawn mower.
- **To ensure the best performance and safety, purchase only genuine Toro replacement parts and accessories. Do not use *will fit* parts and accessories; they may cause a safety hazard.**

Toro Mower Safety

The following list contains safety information specific to Toro products and other safety information you must know.

This product is capable of amputating hands and feet and throwing objects. Always follow all safety instructions to avoid serious injury or death.

This product is designed for cutting and recycling grass or, when equipped with a grass bagger, for catching cut grass. Any use for purposes other than these could prove dangerous to user and bystanders.

Slope Operation

All slopes and ramps require extra caution. If you feel uneasy on a slope, do not mow it.

- Remove obstacles such as rocks, tree limbs, etc. from the mowing area.
- Watch for holes, ruts or bumps. Tall grass can hide obstacles.
- Use caution near drop-offs, ditches, or embankments. The machine could suddenly turn over if a wheel goes over the edge of a cliff or ditch, or if an edge caves in.
- Use extra care with grass catchers or other attachments. These can change the stability of the machine.
- Keep all movement on slopes slow and gradual. Do not make sudden changes in speed or direction.
- Mow slopes side to side.
- Do not mow slopes greater than 20 degrees.

Sound Pressure

This unit has a sound pressure level at the operator's ear of 88 dBA, which includes an Uncertainty Value (K) of 1 dBA.

Maintenance and Storage

- Keep all nuts, bolts and screws tight to be sure the equipment is in safe working condition.
- Do not use pressure cleaning equipment on machine.
- Never store the equipment with gasoline in the tank and inside a building where fumes can reach an open flame or spark.
- Allow the engine to cool before storing in any enclosure.
- To reduce the fire hazard, keep the engine, silencer, battery compartment and gasoline storage are free of grass, leaves, or excessive grease.

The sound pressure level was determined according to the procedures outlined in EN 836.

Sound Power

This unit has a guaranteed sound power level of 100 dBA, which includes an Uncertainty Value (K) of 1 dBA.

The sound power level was determined according to the procedures outlined in ISO 11094.

Vibration Level

Hand-Arm

Measured vibration level for right hand = 2.1 m/s²

Measured vibration level for left hand = 1.7 m/s²

Uncertainty Value (K) = 1.1 m/s²

Measured values were determined according to the procedures outlined in EN 836.

Slope Indicator



2

Figure 3

This page may be copied for personal use.

1. The maximum slope you can safely operate the machine on is **20 degrees**. Use the slope chart to determine the degree of slope of hills before operating. **Do not operate this machine on a slope greater than 20 degrees**. Fold along the appropriate line to match the recommended slope.
2. Align this edge with a vertical surface, a tree, building, fence pole, etc.
3. Example of how to compare slope with folded edge.

Safety and Instructional Decals



Safety decals and instructions are easily visible to the operator and are located near any area of potential danger. Replace any decal that is damaged or lost.



93-7298

1. Traction drive—forward
2. Pull to brake



98-3264

1. Read the *Operator's Manual*.



93-7299

1. Traction drive—reverse



98-4387

1. Warning—wear hearing protection.



93-7442

1. Parking brake

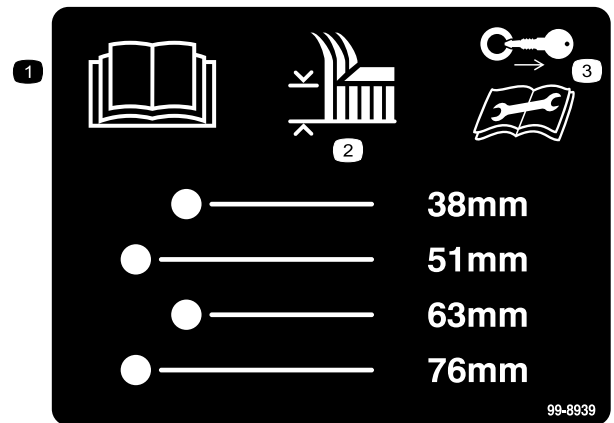

99-8939

1. Read the *Operator's Manual*.
2. Height of cut
3. Remove the ignition key and read the instructions before servicing or performing maintenance.

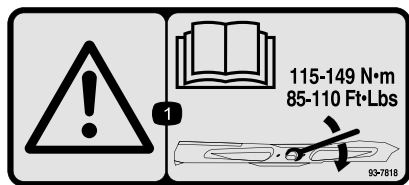

93-7818

1. Warning—read the *Operator's Manual* for instructions on torquing the blade bolt/nut to 115-149 N·m (85-110 ft-lb).



Manufacturer's Mark

1. Indicates the blade is identified as a part from the original machine manufacturer.

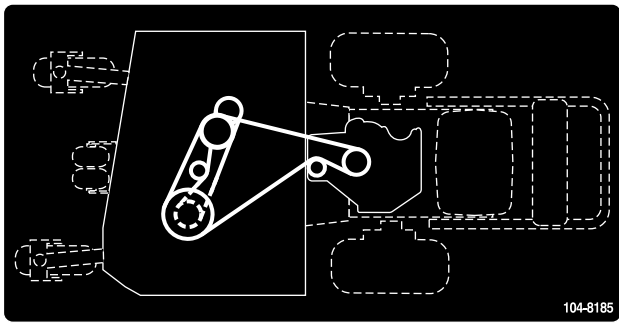

104-8185

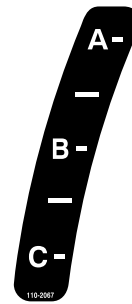

110-2067

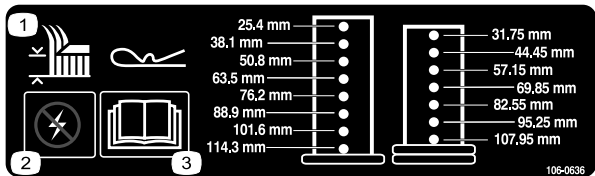

106-0636

1. Height-of-cut
2. Warning—power
3. Read the *Operator's Manual* for more information.

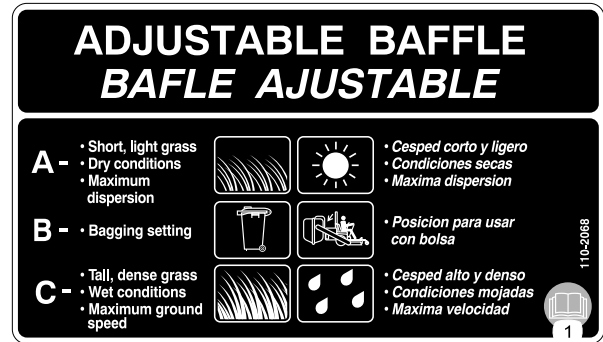

110-2068

1. Read the *Operator's Manual*.



106-5517

1. Warning—do not touch the hot surface.

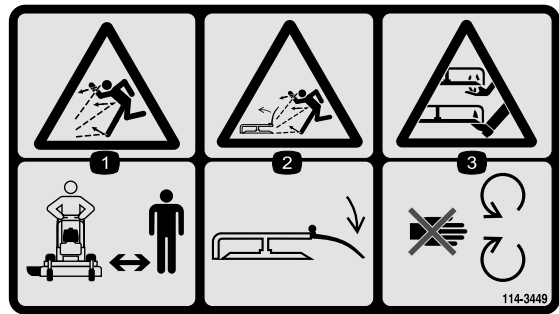

114-3449

1. Thrown object hazard—keep bystanders a safe distance from the machine.
2. Thrown object hazard, mower—keep the deflector in place.
3. Cutting/dismemberment of hand or foot—stay away from moving parts.

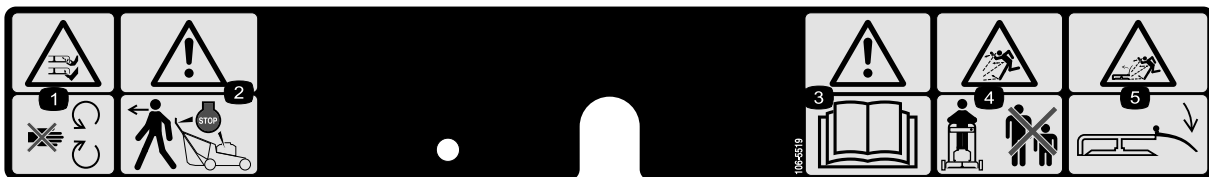

106-5519

1. Cutting/dismemberment hazard of hand or foot, mower blade—stay away from moving parts.
2. Warning—stop the engine before leaving the machine.
3. Warning—read the *Operator's Manual*.
4. Thrown object hazard—keep bystanders a safe distance from the machine.
5. Thrown object hazard, mower—keep the deflector in place.

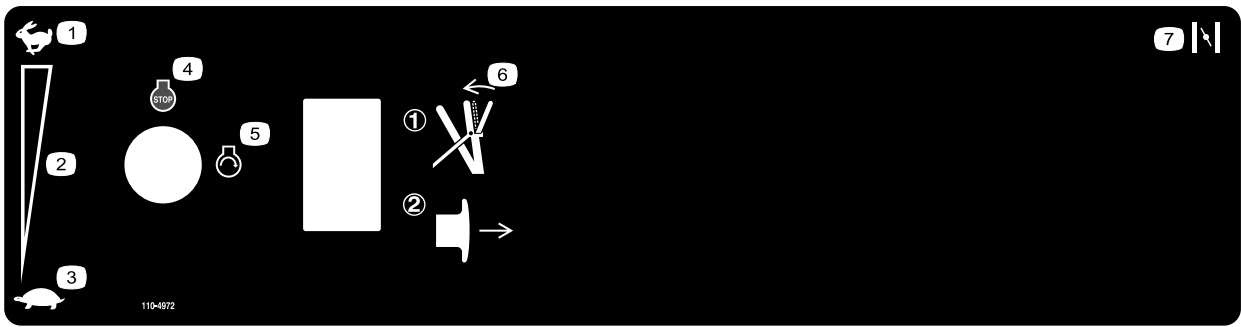

110-4972

- | | | | |
|--------------------------------|----------------|--|----------|
| 1. Fast | 3. Slow | 5. Engine—Start | 7. Choke |
| 2. Continuous variable setting | 4. Engine—stop | 6. Engage bale then pull out on the PTO to engage the blade. | |



119-0217

1. Warning—stop the engine; stay away from moving parts; keep all guards and shields in place.

Product Overview

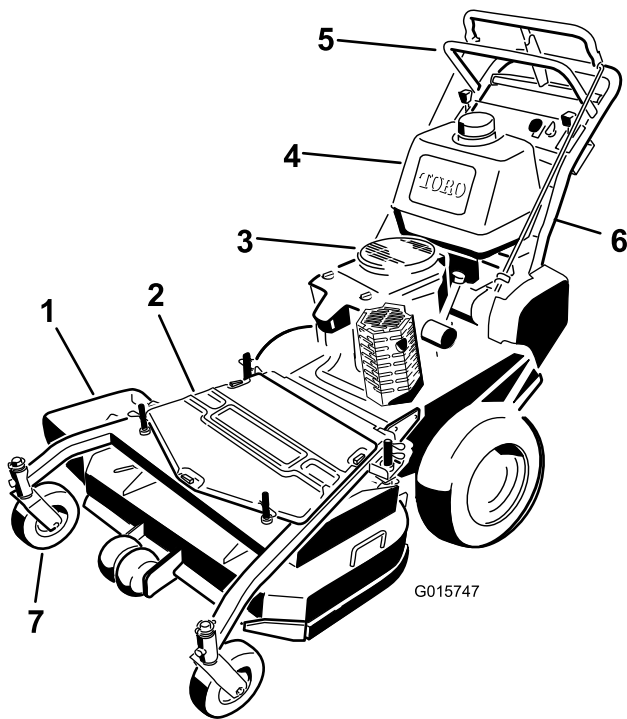

Figure 4

- | | |
|-------------------------|-----------------|
| 1. Side discharge chute | 5. Controls |
| 2. Mower deck | 6. Handle |
| 3. Recoil starter | 7. Caster wheel |
| 4. Gas tank | |

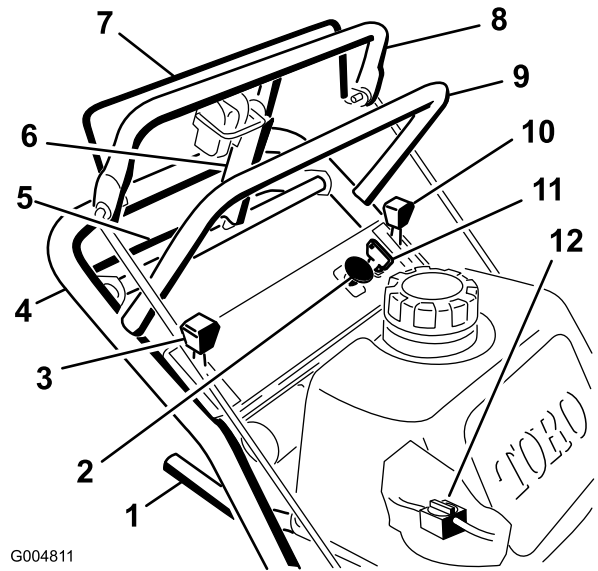

Figure 5

- | | |
|--|-------------------------|
| 1. Gear shift lever | 7. Blade control bail |
| 2. Power take off switch (PTO) | 8. Upper control bar |
| 3. Choke control | 9. Upper handle |
| 4. Lower handle | 10. Throttle control |
| 5. Lower control bar | 11. Ignition switch |
| 6. Parking brake lever-released position | 12. Fuel shut-off valve |

Controls

Become familiar with all the controls (Figure 5) before you start the engine and operate the machine.

Throttle Control

The throttle control has two positions: **Fast** and **Slow**.

Choke

Use the choke to start a cold engine.

Blade Control Bail

The bail is used in conjunction with the power take off switch (PTO) to engage the clutch to drive the mower blades. Release the mower control bail to disengage the mower blades.

Power Take Off Switch (PTO)

This pull switch is used in conjunction with the blade control bail to engage the clutch to drive the mower blades.

Gear Shift Lever

The transmission has five forward speeds, neutral and reverse, and has an in-line shift pattern.

Important: Do not shift while unit is moving, as transmission damage may occur.

Upper Control Bar

Shift to the desired gear and push forward on the upper control bar to engage forward traction operation and pull

back to brake forward movement. Pull back on right side of upper control bar to turn right and left side to turn left.

Lower Control Bar

Shift transmission to reverse and squeeze the lower control bar and handle together to engage rearward traction assist operation.

Parking Brake Lever

Pull back on upper control bar and swing brake lever up against the upper handle (Figure 5).

Ignition Switch

This switch is used in conjunction with recoil starter and has two positions: **Run** and **Off**.

Recoil Starter

Pull recoil starter handle to start engine (not shown in Figure 5).

Fuel Shut-off Valve

Close the fuel shut-off valve when transporting or storing mower.

Specifications

Note: Specifications and design are subject to change without notice.

Width with deflector down	130 cm (51-1/8 inches)
Length	210 cm (82-3/4 inches)
Height with handle in lowest position	105 cm (41-3/16 inches)
Weight	271 kg (598 lb)

Attachments/Accessories

A selection of Toro approved attachments and accessories is available for use with the machine to enhance and expand its capabilities. Contact your Authorized Service Dealer or Distributor or go to www.Toro.com for a list of all approved attachments and accessories.

Operation

Note: Determine the left and right sides of the machine from the normal operating position.

Adding Fuel

- For best results, use only clean, fresh (less than 30 days old), unleaded gasoline with an octane rating of 87 or higher ((R+M)/2 rating method).
- **Ethanol:** Gasoline with up to 10% ethanol (gasohol) or 15% MTBE (methyl tertiary butyl ether) by volume is acceptable. Ethanol and MTBE are not the same. Gasoline with 15% ethanol (E15) by volume is not approved for use. **Never use gasoline that contains more than 10% ethanol by volume**, such as E15 (contains 15% ethanol), E20 (contains 20% ethanol), or E85 (contains up to 85% ethanol). Using unapproved gasoline may cause performance problems and/or engine damage which may not be covered under warranty.
- **Do not** use gasoline containing methanol.
- **Do not** store fuel either in the fuel tank or fuel containers over the winter unless a fuel stabilizer is used.
- **Do not** add oil to gasoline.

▲ DANGER

In certain conditions, gasoline is extremely flammable and highly explosive. A fire or explosion from gasoline can burn you and others and can damage property.

- **Fill the fuel tank outdoors, in an open area, when the engine is cold. Wipe up any gasoline that spills.**
- **Never fill the fuel tank inside an enclosed trailer.**
- **Do not fill the fuel tank completely full. Add gasoline to the fuel tank until the level is 6 to 13 mm (1/4 to 1/2 inch) below the bottom of the filler neck. This empty space in the tank allows gasoline to expand.**
- **Never smoke when handling gasoline, and stay away from an open flame or where gasoline fumes may be ignited by a spark.**
- **Store gasoline in an approved container and keep it out of the reach of children. Never buy more than a 30-day supply of gasoline.**
- **Do not operate without entire exhaust system in place and in proper working condition.**

⚠ DANGER

In certain conditions during fueling, static electricity can be released causing a spark which can ignite the gasoline vapors. A fire or explosion from gasoline can burn you and others and can damage property.

- Always place gasoline containers on the ground away from your vehicle before filling.
- Do not fill gasoline containers inside a vehicle or on a truck or trailer bed because interior carpets or plastic truck bed liners may insulate the container and slow the loss of any static charge.
- When practical, remove gas-powered equipment from the truck or trailer and refuel the equipment with its wheels on the ground.
- If this is not possible, then refuel such equipment on a truck or trailer from a portable container, rather than from a gasoline dispenser nozzle.
- If a gasoline dispenser nozzle must be used, keep the nozzle in contact with the rim of the fuel tank or container opening at all times until fueling is complete.

⚠ WARNING

Gasoline is harmful or fatal if swallowed. Long-term exposure to vapors can cause serious injury and illness.

- Avoid prolonged breathing of vapors.
- Keep face away from nozzle and gas tank or conditioner bottle opening.
- Avoid contact with skin; wash off spillage with soap and water.

Using Stabilizer/Conditioner

Use a fuel stabilizer/conditioner in the machine to provide the following benefits:

- Keeps gasoline fresh during storage of 90 days or less. For longer storage it is recommended that the fuel tank be drained.
- Cleans the engine while it runs
- Eliminates gum-like varnish buildup in the fuel system, which causes hard starting

Important: Do not use fuel additives containing methanol or ethanol.

Add the correct amount of gas stabilizer/conditioner to the gas.

Note: A fuel stabilizer/conditioner is most effective when mixed with fresh gasoline. To minimize the chance of varnish deposits in the fuel system, use fuel stabilizer at all times.

Filling the Fuel Tank

1. Shut the engine off and set the parking brake.
2. Clean around the fuel tank cap and remove the cap. Add unleaded regular gasoline to the fuel tank, until the level is 6 to 13 mm (1/4 to 1/2 inch) below the bottom of the filler neck. This space in the tank allows the gasoline to expand. Do not fill the fuel tank completely full.
3. Install the fuel tank cap securely. Wipe up any gasoline that may have spilled.

Checking the Engine Oil Level

Before you start the engine and use the machine, check the oil level in the engine crankcase; refer to Checking Oil Level in Engine Maintenance (page 23)

Note: Determine the left and right sides of the machine from the normal operating position.

Think Safety First

Carefully read all the safety instructions and decals in the safety section. Knowing this information could help you or any bystanders avoid injury.

The use of protective equipment for eyes, hearing, feet and head is recommended.

⚠ CAUTION

This machine produces sound levels in excess of 85 dBA at the operator's ear and can cause hearing loss through extended periods of exposure.

Wear hearing protection when operating this machine.



Figure 6

1. Warning—wear hearing protection.

Using the Parking Brake

Stop on level ground, disengage drives, engage parking brake, shut off engine and remove key. Always set the parking brake when you stop the machine or leave it unattended.

Setting the Parking Brake

1. Pull the upper control bar (Figure 7) rearward and hold it in this position.
2. Lift the parking brake lock (Figure 7) up and gradually release the upper control bar. The brake lock should stay in the set (locked) position.

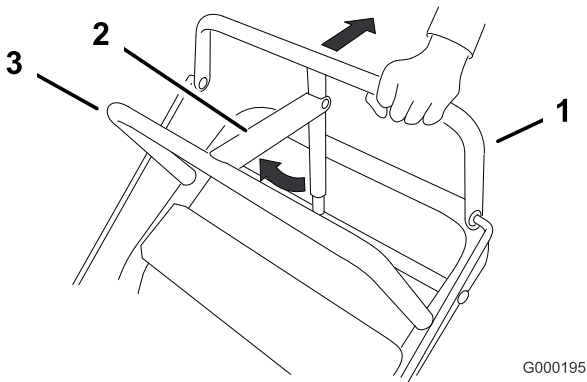

Figure 7

1. Upper control bar
2. Parking brake lever-set position
3. Fixed bar

Important: Do not pull recoil rope to its limit or let go of the starter handle when rope is pulled out because rope may break or recoil assembly may be damaged.

Stopping the Engine

1. Move the throttle lever to the **slow** position (Figure 8).
2. Let engine idle for 30 to 60 seconds before turning the ignition key to **off**.
3. Turn the ignition key to **off** (Figure 8).

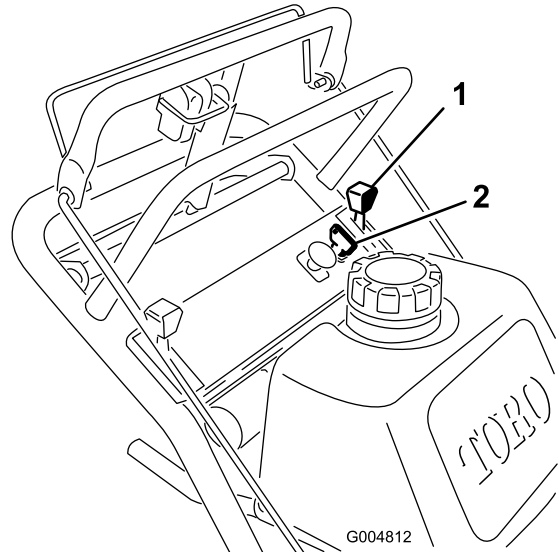

Figure 8

1. Throttle lever
2. Ignition key

Releasing the Parking Brake

1. Pull rearward on the upper control bar. Lower the parking brake lock to the released position.
2. Gradually release the upper control bar.

Starting and Stopping the Engine

Starting the Engine

1. Make sure spark plug wire(s) are installed on spark plug(s) and fuel valve is open.
2. Move the shift lever to neutral, set the parking brake and turn ignition key to run.
3. Move the throttle control to fast and move the choke lever to the on position before starting a cold engine.

Note: A warm or hot engine usually does not require any choking. To start a warm engine, move throttle control to the **fast** position.

4. Grasp recoil starter handle firmly and pull out until positive engagement results; then pull handle vigorously to start engine and allow rope to recoil slowly.

4. Set the parking brake and remove key.
5. Pull wire off spark plug(s) to prevent possibility of accidental starting before storing machine.
6. Close the fuel shut off valve before storing machine.

Important: Make sure fuel shut off valve is closed before transporting or storing machine, as fuel leakage may occur.

Operating the Mower Power Take Off (PTO)

The power take off switch (PTO) in conjunction with the blade control bail engages and disengages power to the electric clutch and mower blades.

Engaging the Mower Blades (PTO)

1. Release the upper control bar to stop the machine (Figure 9).
2. To engage blade, squeeze blade control bail against the upper control bar (Figure 9).

3. Pull the power take off switch (PTO) up and release. Hold the blade control bail against the upper control bar while operating.
4. Repeat the procedure to engage the mower blades if the blade control bail is released.

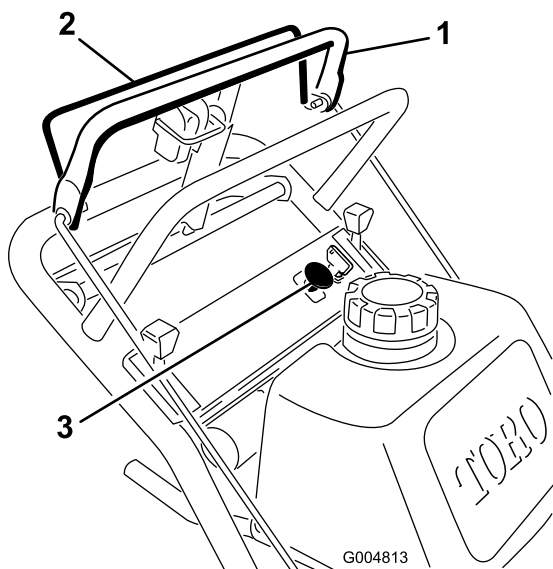

Figure 9

- | | |
|-----------------------|--------------------------------|
| 1. Upper control bar | 3. Power take off switch (PTO) |
| 2. Blade control bail | |

Disengaging the Mower Blades (PTO)

Release the blade control bail to disengage the blades (Figure 9).

The Safety Interlock System

⚠ CAUTION

If safety interlock switches are disconnected or damaged the machine could operate unexpectedly causing personal injury.

- Do not tamper with the interlock switches.
- Check the operation of the interlock switches daily and replace any damaged switches before operating the machine.

Understanding the Safety Interlock System

The safety interlock system is designed to prevent the mower blades from rotating unless:

- The control bail is depressed.
- The power take off switch (PTO) is pulled on.

The safety interlock system is designed to stop the mower blades if you release the blade control bail.

Testing the Safety Interlock System

Test the safety interlock system before you use the machine each time.

Note: If the safety system does not operate as described below, have an Authorized Service Dealer repair the safety system immediately.

1. Set the parking brake and start the engine; refer to Starting and Stopping the Engine.
2. Squeeze the blade control bail against upper control bar. **The blades should not rotate.**
3. Then continue holding the blade control bail and pull up on the blade control switch and release. The clutch should engage and the mower blades begin rotating.
4. Release the blade control bail. **The blades should stop rotating.**
5. With the engine running, pull up the power take off switch (PTO) and release without holding the blade control bail. **The blades should not rotate.**

Driving Forward or Backward

The throttle control regulates the engine speed as measured in RPM (revolutions per minute). Place the throttle control in the **fast** position for best mowing performance.

Driving Forward

1. To go forward, move the shift lever to a forward gear (Figure 10).
2. Release the parking brake; refer to Releasing the Parking Brake in Brake Maintenance (page 31).
3. Slowly press on the upper control bar to move forward (Figure 10).

To go straight, apply equal pressure to both ends of the upper control bar (Figure 10).

To turn, release pressure on the upper control bar side in the direction you want to turn (Figure 10).

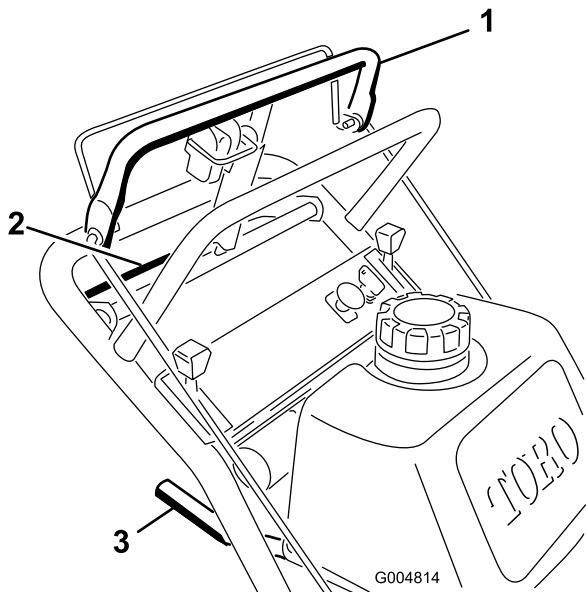

Figure 10

- 1. Upper control bar
- 2. Lower control bar
- 3. Shift lever

Driving Backward

1. To go backward, move the shift lever to reverse gear.
2. Release the parking brake; refer to Releasing the Parking Brake.
3. Slowly squeeze the lower control bar and lower handle together to move rearward (Figure 10).

Using the Lower Control Bar

This procedure is for driving up a curb. This can be performed while driving forward or backward.

Note: Some curbs do not allow the rear drive tires to contact the curb. If this happens, drive the machine up the curb at an angle.

⚠ WARNING

A blade can be bent or damaged when driving up a curb. Pieces of blade that may be thrown could seriously injure or kill you or bystanders.

Do not run blades while driving up a curb forward or backward.

Driving Forward Up a Curb

1. Disengage the mower blades.
2. Select first gear to drive the machine.
3. Drive machine until the castor wheels contact curb (Figure 11).
4. Lift the front of the machine by pushing down on the lower handle (Figure 11).

5. Drive the machine until drive wheels contact the curb (Figure 11).
 6. Lower the front of the machine (Figure 11).
- Note:** Both drive wheels should contact the curb and caster wheels straight.
7. At the same time engage the lower control bar and lift up on the lower handle to drive over the curb (Figure 10 and Figure 11).

Note: Lifting up on the lower handle will assist driving the machine up a curb and not spin the drive wheels.

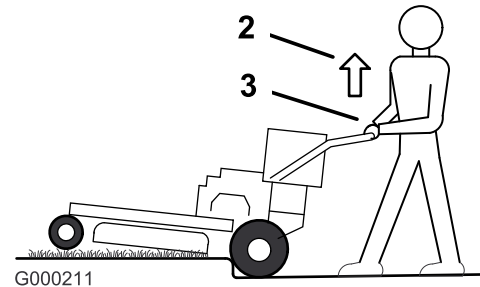
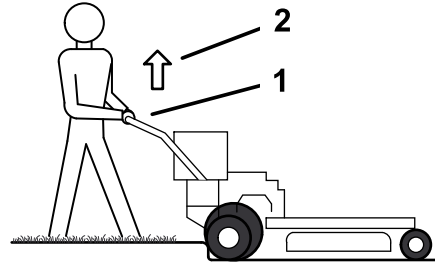

Figure 11

- 1. Lower Control Bar engaged and mower in reverse.
- 2. Pull up to assist machine
- 3. Lower Control Bar engaged and mower going forward.

Driving Backward Up a Curb

1. Disengage the mower blades.
 2. Select reverse to drive machine.
 3. Drive the machine until drive wheels contact curb (Figure 11).
- Note:** Both drive wheels should contact the curb and caster wheels straight.
4. At the same time engage lower control bar and lift up on the lower handle (Figure 10 and Figure 11).

Note: Lifting up on the lower handle will assist driving the machine up a curb and not spin the drive wheels.

Stopping the Machine

To stop the machine, pull back on the upper control bar, release the blade control bail, and turn the ignition key to off. Also set the parking brake if you leave the machine

unattended; refer to Setting the Parking Brake in (page). Remember to remove the key from the ignition switch.

⚠ CAUTION

Children or bystanders may be injured if they move or attempt to operate the machine while it is unattended.

Always remove the ignition key and set the parking brake when leaving the machine unattended, even if just for a few minutes.

Transporting Machines

Use a heavy-duty trailer or truck to transport the machine. Ensure that the trailer or truck has all necessary brakes, lighting, and marking as required by law. Please carefully read all the safety instructions. Knowing this information could help you, your family, pets or bystanders avoid injury.

To transport the machine:

1. If using a trailer, connect it to the towing vehicle and connect the safety chains.
2. If applicable, connect the trailer brakes.
3. Load the machine onto the trailer or truck.
4. Stop the engine, remove the key, set the brake, and close the fuel valve.
5. Use the metal tie down loops on the machine to securely fasten the machine to the trailer or truck with straps, chains, cable, or ropes (Figure 12).

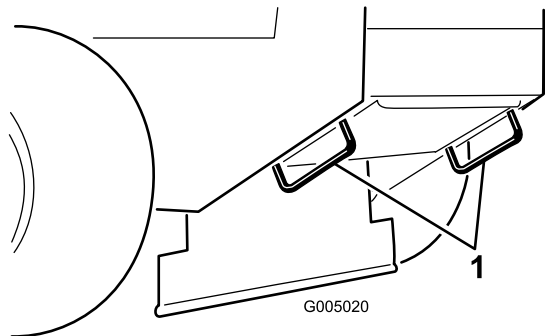

Figure 12

1. Traction unit tie down loop

⚠ DANGER

Without the grass deflector, discharge cover, or complete grass catcher assembly mounted in place, you and others are exposed to blade contact and thrown debris. Contact with rotating mower blade(s) and thrown debris will cause injury or death.

- Never remove the grass deflector from the mower because the grass deflector routes material down toward the turf. If the grass deflector is ever damaged, replace it immediately.
- Never put your hands or feet under the mower.
- Never try to clear discharge area or mower blades unless you release the bail and the power take off (PTO) is off. Rotate the ignition key to Off. Also remove the key and pull the wire(s) off the spark plug(s).

Adjusting the Height-of-Cut

The height-of-cut can be adjusted from 25 to 114 mm (1 to 4-1/2 inch) in 6 mm (1/4 inch) increments. Adjustment is done by relocating four hairpin cotter pins in different hole location and by adding or removing spacers.

Note: All height-of-cut pins need at least one spacer or damage can occur to bushing if none are used.

Note: All height-of-cut pins can use two spacers maximum.

1. Select hole in height-of-cut post and number of spacers corresponding to the height-of-cut desired (Figure 13).
2. Using the lift handle, raise side of deck and remove hairpin cotter (Figure 13).
3. Add or remove spacers if needed and then align holes and insert hairpin cotter (Figure 13).

Note: Spare height-of-cut spacers may be stored on posts and retained by a hairpin cotter.

Important: All four hairpin cotter pins must be in the same hole location and with the correct number of spacers for a level cut.

Side Discharging or Mulching the Grass

This mower has a hinged grass deflector that disperses clippings to the side and down toward the turf.

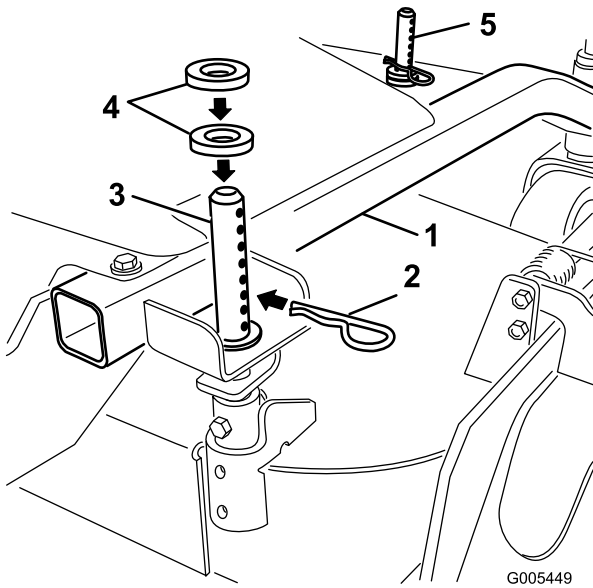
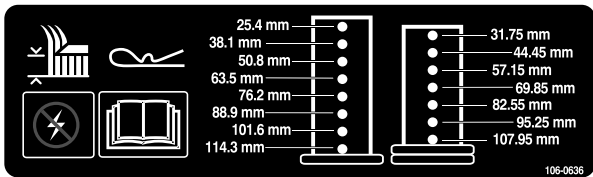

Figure 13

- | | |
|----------------------------|-----------------------------|
| 1. Carrier Frame | 4. Spacers |
| 2. Hairpin Cotter | 5. Front height-of-cut post |
| 3. Back height-of-cut post | |

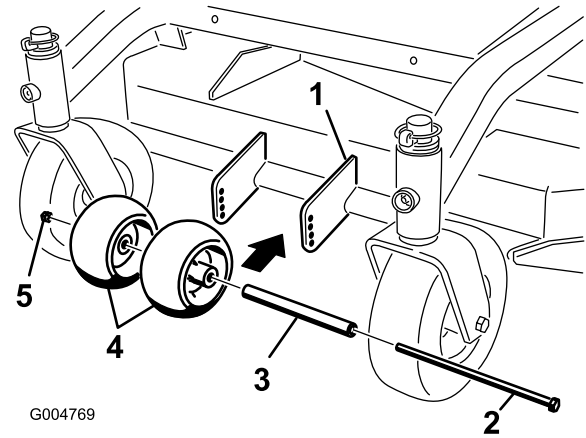

Figure 14

- | | |
|---------------|-----------------------|
| 1. Mower deck | 4. Anti-Scalp Rollers |
| 2. Bolt | 5. Nut |
| 3. Spacer | |

Adjusting the Anti-Scalp Rollers

The anti-scalp rollers need to be adjusted in the proper hole location for each height-of-cut position. Ensure the minimum clearance above the ground is 10 mm (3/8 inch).

Note: If the anti-scalp rollers are adjusted too low can cause excess wear of the rollers.

1. After adjusting height-of-cut, check the anti-scalp rollers so that there is a minimum of 10 mm (3/8 inch) clearance above the ground (Figure 14).
2. If adjustment is needed, remove the bolt, washers and nut (Figure 14).
3. Select a hole position so the anti-scalp rollers are a minimum of 10 mm (3/8 inch) off the ground (Figure 14).
4. Install the bolt and nut (Figure 14).

Adjusting the Handle Height

The handle position can be adjusted to match the operator's height preference.

1. Remove hairpin cotter, washer and clevis pin securing control rod fitting to idler bracket (Figure 15).

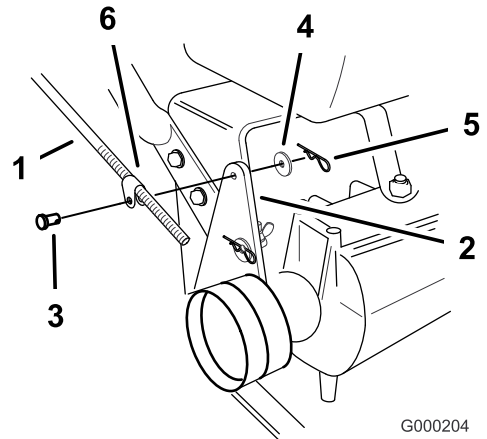

Figure 15

- | | |
|----------------------------|-----------------------|
| 1. Control rod and fitting | 4. Washer |
| 2. Idler bracket | 5. Hairpin cotter pin |
| 3. Clevis pin | 6. Rod fitting |

2. Loosen the upper flange bolts (3/8 x 1 inch) and flange nut securing handle to rear frame (Figure 16).

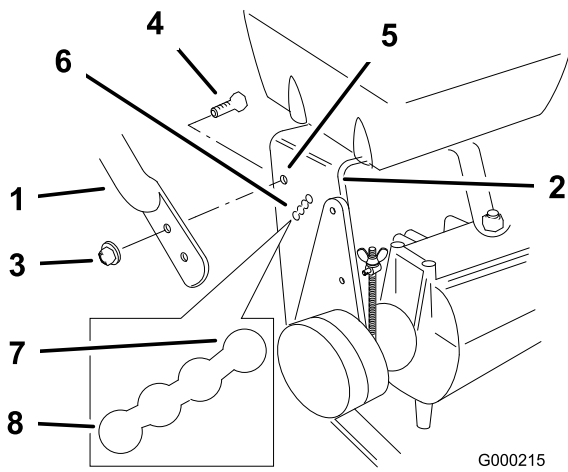

Figure 16

- | | |
|--------------------------------|-------------------------|
| 1. Upper handle | 5. Upper mounting hole |
| 2. Rear frame | 6. Lower mounting holes |
| 3. Flange nut, (3/8 inch) | 7. Low position |
| 4. Flange bolt, (3/8 x 1 inch) | 8. High position |

- Remove the lower flange bolts (3/8 x 1 inch) and flange nuts securing handle to rear frame (Figure 16).
- Pivot handle to desired operating position and install lower flange bolts (3/8 x 1 inch) and flange nuts into mounting holes. Tighten all flange bolts.
- Check the control bar for correct adjustment. Refer to Adjusting the Control Bar in the maintenance section.
- Check the parking brake adjustment. Refer to Checking the Brakes in the maintenance section.

Adjusting the Flow Baffle

The mower discharge flow can be adjusted for different types of mowing conditions. Position the cam lock and baffle to give the best quality of cut.

- Disengage the PTO, move the motion control levers to the neutral locked position and set the parking brake.
- Stop the engine, remove the key, and wait for all moving parts to stop before leaving the operating position.
- To adjust the baffle, loosen the nut (Figure 17).
- Adjust the baffle and nut in the slot to the desired discharge flow and tighten the nut.

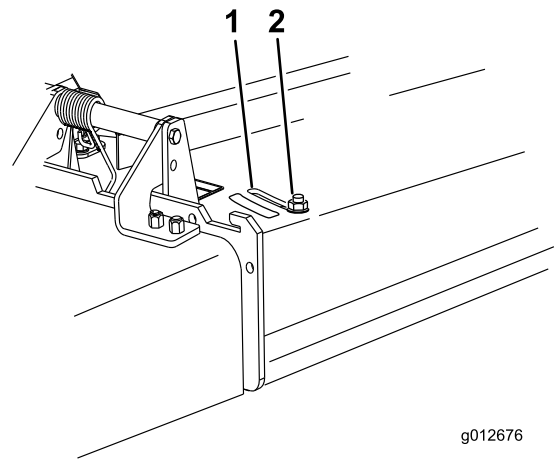

Figure 17

- | | |
|---------|--------|
| 1. Slot | 2. Nut |
|---------|--------|

Positioning the Flow Baffle

The following figures are only recommendations for use. Adjustments will vary by grass type, moisture content, and height of grass.

Note: If the engine power draws down and the mower ground speed is the same, open up the baffle.

Position A

This is the full rear position (see Figure 18). The suggested use for this position is as follows.

- Use for short, light grass mowing conditions.
- Use in dry conditions.
- For smaller grass clippings.
- Propels grass clippings farther away from the mower.

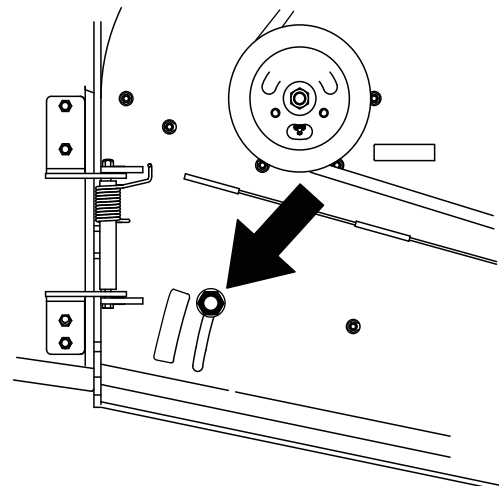

Figure 18

Position B

Use this position when bagging (Figure 19).

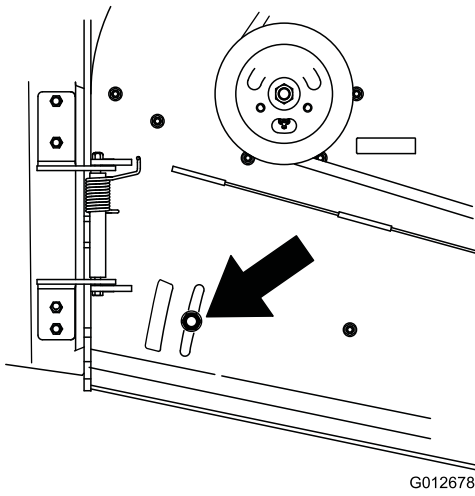

Figure 19

⚠ WARNING

The front end of the machine can rapidly rise up when the mower is removed. This could cause serious injury to you or bystanders.

Support the rear of the machine when removing the mower from the carrier frame.

Position C

This is the full open position. The suggested use for this position is as follows (Figure 20).

- Use in tall, dense grass mowing conditions.
- Use in wet conditions.
- Lowers the engine power consumption.
- Allows increased ground speed in heavy conditions.

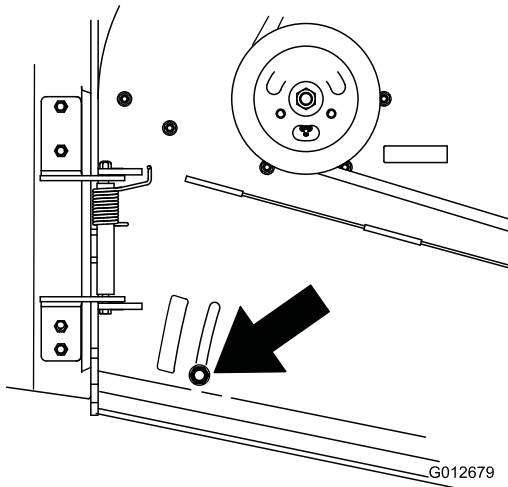

Figure 20

Using the Mid-Size Weight

- Any rear weight must be removed when a Tru-Track® Sulky is installed.
- When a Tru-Track® Sulky is installed front weights are needed. Contact an Authorized Service Dealer for the correct quantity of weights and placement.

Maintenance

Note: Determine the left and right sides of the machine from the normal operating position.

Recommended Maintenance Schedule(s)

Maintenance Service Interval	Maintenance Procedure
After the first 8 hours	<ul style="list-style-type: none"> • Change the engine oil.
Before each use or daily	<ul style="list-style-type: none"> • Check the safety system. • Grease the caster wheels and caster pivot. • Check the engine oil level. • Clean the air intake screen. • Check the brakes. • Inspect the blades.
Every 25 hours	<ul style="list-style-type: none"> • Clean foam air cleaner element.
Every 50 hours	<ul style="list-style-type: none"> • Grease the PTO belt idler. • Grease the mower deck belt idler. • Check the paper air cleaner element. • Check the tire pressure. • Check all belts.
Every 100 hours	<ul style="list-style-type: none"> • Change the engine oil. • Check the spark plugs. • Check the electric clutch.
Every 200 hours	<ul style="list-style-type: none"> • Replace the paper air cleaner element. • Change the oil filter. • Replace the fuel filter.
Every 250 hours	<ul style="list-style-type: none"> • Grease the transmission couplers (more often in dirty or dusty conditions).
Every 400 hours	<ul style="list-style-type: none"> • Grease the wheel bearings (more often in dirty or dusty conditions).
Before storage	<ul style="list-style-type: none"> • Paint chipped surfaces. • Perform all maintenance procedures listed above before storage.

Important: Refer to your engine operator's manual for additional maintenance procedures.

⚠ CAUTION

If you leave the key in the ignition switch, someone could accidentally start the engine and seriously injure you or other bystanders.

Remove the key from the ignition and disconnect the spark plug wires from the spark plugs before you do any maintenance. Set the wires aside so that they do not accidentally contact the spark plugs.

Lubrication

Grease with No. 2 general purpose lithium base or molybdenum base grease.

How to Grease

1. Disengage the PTO and set the parking brake.
2. Stop the engine, remove the key, and wait for all moving parts to stop before leaving the operating position.
3. Clean the grease fittings with a rag. Make sure to scrape any paint off the front of the fitting(s).

4. Connect a grease gun to the fitting. Pump grease into the fittings until grease begins to ooze out of the bearings.
5. Wipe up any excess grease.

Lubricating the Caster and Wheel Bearings

1. Lubricate the front caster wheel bearings and front pivots (Figure 21).

2. Raise the rear of the machine and use jack stands to support the machine.
3. Remove the rear wheel and tire assemblies.
4. Remove rear wheel grease cap. Lubricate the rear wheel bearing (Figure 21).
5. Install the grease cap.
6. Install the rear wheel and tire assembly.

Note: Make sure the rear wheel grease caps are removed before lubricating rear wheels.

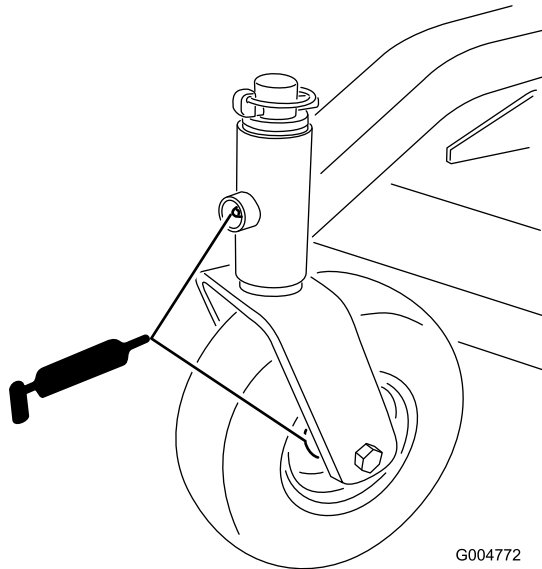

Figure 21

G004772

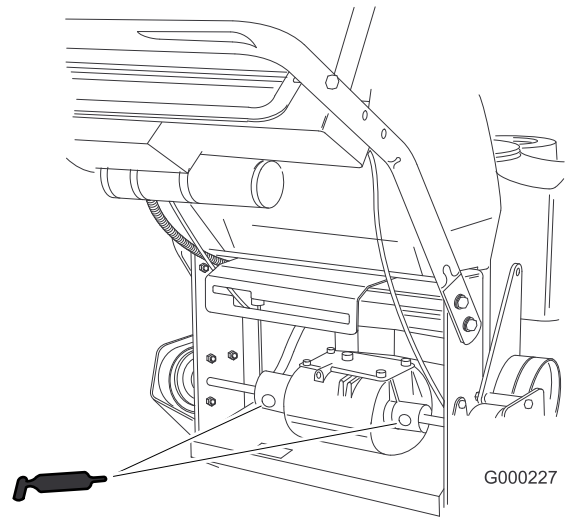

Figure 22

G000227

Greasing the PTO Drive Belt Idler and Mower Deck Belt Idler

Service Interval: Every 50 hours

Every 50 hours

Grease the idler pulley pivot (Figure 23).

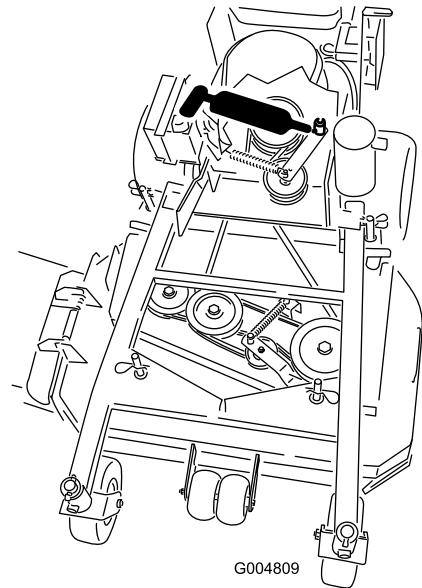

Figure 23

G004809

Greasing the Transmission Couplers

Service Interval: Every 250 hours

Lubricate the transmission couplers located in the back of the machine (Figure 22).

Engine Maintenance

Servicing the Air Cleaner

Service Interval/Specification

Service Interval: Every 25 hours

Every 50 hours

Every 200 hours/Yearly (whichever comes first)

Inspect the foam and paper elements and replace them if they are damaged or excessively dirty.

Note: Service the air cleaner more frequently (every few operating hours) if the operating conditions are extremely dusty or sandy.

Important: Do not oil the foam or paper element.

Removing the Foam and Paper Elements

1. Disengage the PTO and set the parking brake.
2. Stop the engine, remove the key, and wait for all moving parts to stop before leaving the operating position.
3. Clean around the air cleaner to prevent dirt from getting into the engine and causing damage (Figure 24).
4. Unscrew the cover knobs and remove the air cleaner cover (Figure 24).
5. Unscrew the hose clamp and remove the air cleaner assembly (Figure 24).
6. Carefully pull the foam element off the paper element (Figure 24).

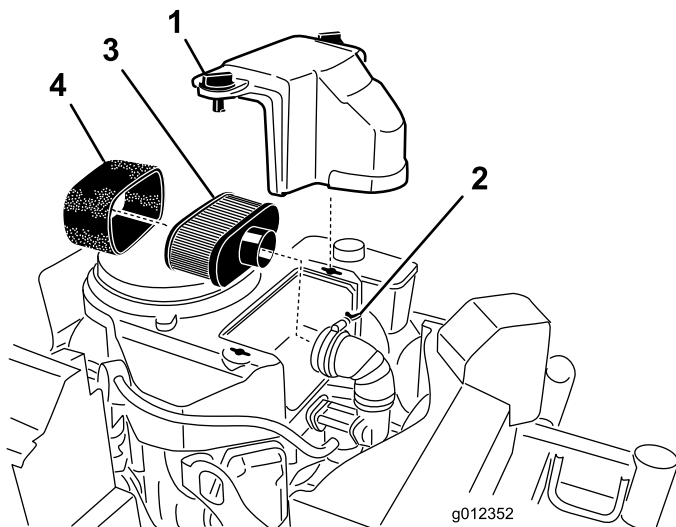

Figure 24

2. Dry the element by squeezing it in a clean cloth.

Important: Replace the foam element if it is torn or worn.

Servicing the Paper Air Cleaner Element

1. Do not clean the paper filter. Replace it (Figure 24).
2. Inspect the element for tears, an oily film, or damage to the rubber seal.
3. Replace the paper element if it is damaged.

Installing the Foam and Paper Elements

Important: To prevent engine damage, always operate the engine with the complete foam and paper air cleaner assembly installed.

1. Carefully slide the foam element onto the paper air cleaner element (Figure 24).
2. Place the air cleaner assembly onto the air cleaner base and secure it with the 2 wing nuts (Figure 24).
3. Place the air cleaner cover into position and tighten the cover knob (Figure 24).

Servicing the Engine Oil

Service Interval/Specification

Service Interval: Before each use or daily

After the first 8 hours

Every 100 hours

Every 200 hours—Change the oil filter.

Note: Change the oil more frequently when the operating conditions are extremely dusty or sandy.

Oil Type: Detergent oil (API service SF, SG, SH, or SJ)

Crankcase Capacity: 58 ounces (1.7 liter) with the filter removed; 51 ounces (1.5 liter) without the filter removed

Viscosity: Refer to the table (Figure 25).

Cleaning the Foam Air Cleaner Element

1. Wash the foam element in liquid soap and warm water. When the element is clean, rinse it thoroughly.

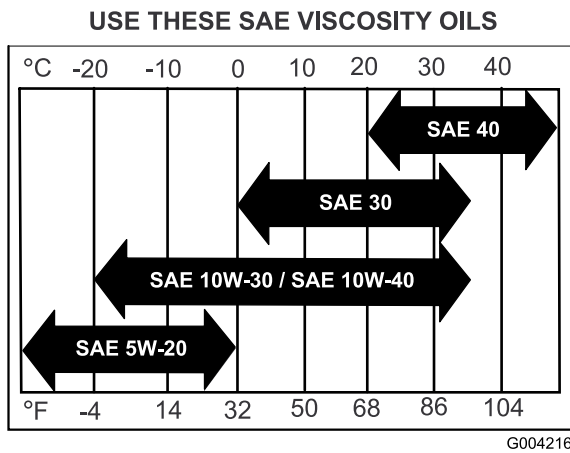

Figure 25

Checking the Engine Oil Level

1. Park the machine on a level surface.
2. Disengage the PTO and set the parking brake.
3. Stop the engine, remove the key, and wait for all moving parts to stop before leaving the operating position.
4. Clean around the oil dipstick (Figure 26) so that dirt cannot fall into the filler hole and damage the engine.

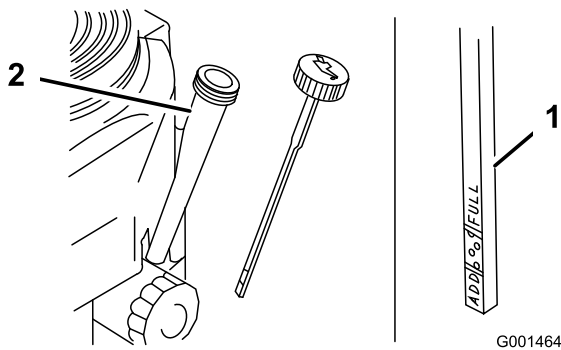

Figure 26

1. Oil dipstick
2. Filler tube

5. Unscrew the oil dipstick and wipe the end clean (Figure 26).
6. Slide the oil dipstick fully into the filler tube, but do not thread onto tube (Figure 26).
7. Pull the dipstick out and look at the end. If the oil level is low, slowly pour only enough oil into the filler tube to raise the level to the Full mark.

Important: Do not overfill the crankcase with oil and run the engine; engine damage can result.

Changing the Oil

1. Park the machine so that the drain side is slightly lower than the opposite side to assure the oil drains completely.

2. Disengage the PTO and set the parking brake.
3. Stop the engine, remove the key, and wait for all moving parts to stop before leaving the operating position.
4. Slide the drain hose over the oil drain valve.
5. Place a pan below the drain hose. Rotate oil drain valve to allow oil to drain (Figure 27).
6. When oil has drained completely, close the drain valve.
7. Remove the drain hose (Figure 27).

Note: Dispose of the used oil at a recycling center.

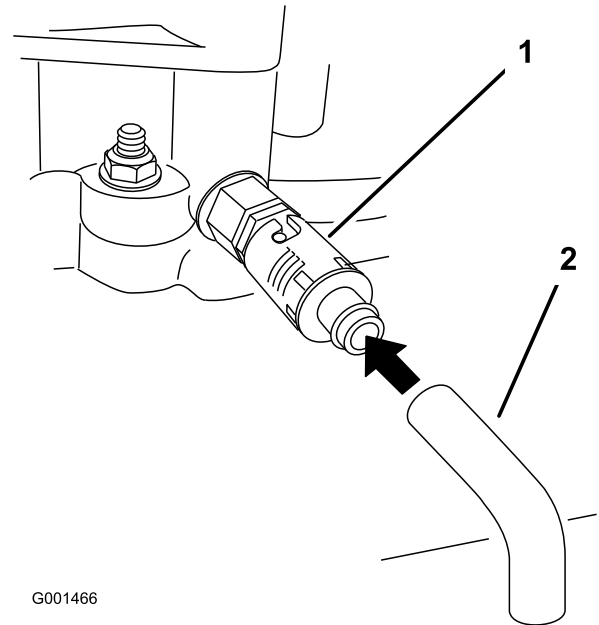

Figure 27

1. Oil drain valve
2. Oil drain hose

8. Slowly pour approximately 80% of the specified oil into the filler tube (Figure 26).
9. Check the oil level; refer to Checking the Engine Oil Level.
10. Slowly add the additional oil to bring it to the **Full** mark.

Changing the Oil Filter

Note: Change the oil filter more frequently when the operating conditions are extremely dusty or sandy.

1. Drain the oil from the engine; refer to Changing the Engine Oil.
2. Remove the old filter (Figure 28).

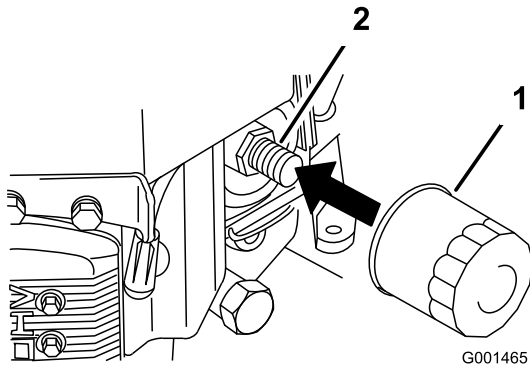

Figure 28

1. Oil filter
2. Adapter

3. Apply a thin coat of new oil to the rubber gasket on the replacement filter (Figure 28).
4. Install the replacement oil filter to the filter adapter, turn the oil filter clockwise until the rubber gasket contacts the filter adapter, then tighten the filter an additional 3/4 turn (Figure 28).
5. Fill the crankcase with the proper type of new oil; refer to Servicing the Engine Oil.
6. Run the engine for about 3 minutes, stop the engine, and check for oil leaks around the oil filter and drain valve.
7. Check the engine oil level and add oil if needed.
8. Wipe up any spilled oil.

Servicing the Spark Plugs

Service Interval/Specification

Service Interval: Every 100 hours

Ensure that the air gap between the center and side electrodes is correct before installing the spark plug. Use a spark plug wrench for removing and installing the spark plugs and a gapping tool/feeler gauge to check and adjust the air gap. Install a new spark plugs if necessary.

Type: Champion® RCJ8Y or equivalent Air Gap: 0.75 mm (0.030 inch)

Removing the Spark Plugs

1. Disengage the PTO and set the parking brake.

2. Stop the engine, remove the key, and wait for all moving parts to stop before leaving the operating position.
3. Disconnect the wires from the spark plugs (Figure 29).

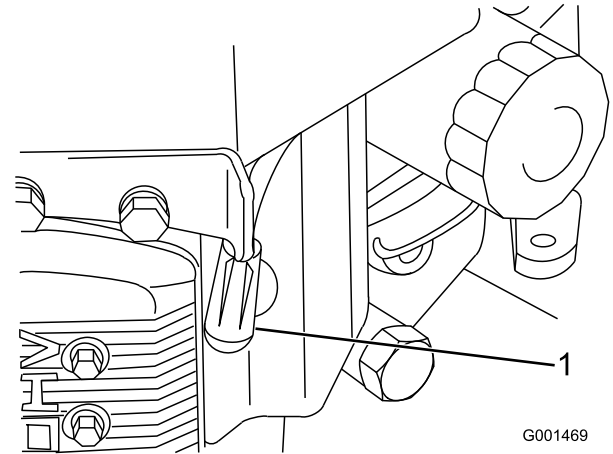

Figure 29

1. Spark-plug wire/spark plug

4. Clean around the spark plugs to prevent dirt from falling into the engine and potentially causing damage.
5. Remove the spark plugs and the metal washers.

Checking the Spark Plugs

1. Look at the center of the spark plugs (Figure 30). If you see light brown or gray on the insulator, the engine is operating properly. A black coating on the insulator usually means that the air cleaner is dirty.
2. If needed, clean the spark plug with a wire brush to remove carbon deposits.

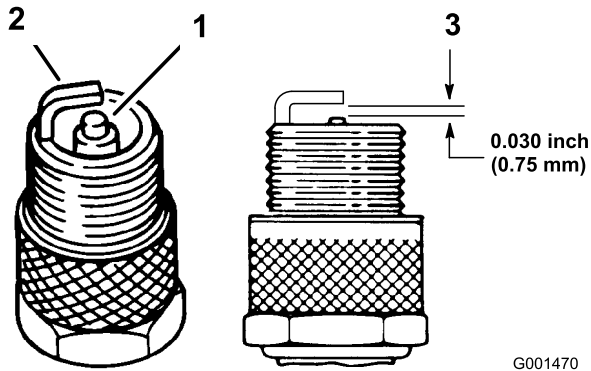

Figure 30

1. Center electrode insulator
2. Side electrode
3. Air gap (not to scale)

Important: Always replace the spark plugs when it has worn electrodes, an oily film on it, or has cracks in the porcelain.

3. Check the gap between the center and side electrodes (Figure 30). Bend the side electrode (Figure 30) if the gap is not correct.

Installing the Spark Plugs

1. Install the spark plugs and the metal washer. Ensure that the air gap is set correctly.
2. Tighten the spark plugs to 22 N-m (16 ft-lb).
3. Connect the wires to the spark plugs (Figure 30).

Fuel System Maintenance

Draining the Fuel Tank

⚠ DANGER

In certain conditions, gasoline is extremely flammable and highly explosive. A fire or explosion from gasoline can burn you and others and can damage property.

- Drain gasoline from the fuel tank when the engine is cold. Do this outdoors in an open area. Wipe up any gasoline that spills.
- Never smoke when draining gasoline, and stay away from an open flame or where a spark may ignite the gasoline fumes.

1. Park the machine on a level surface, to assure fuel tank drains completely. Then disengage the power take off (PTO), set the parking brake, and turn the ignition key to **off**. Remove the key.
2. Close the fuel shut-off valve at the fuel tank (Figure 31).
3. Squeeze the ends of the hose clamp together and slide it up the fuel line away from fuel filter (Figure 31).
4. Pull the fuel line off the fuel filter (Figure 31). Open the fuel shut-off valve and allow the gasoline to drain into a gas can or drain pan.

Note: Now is the best time to install a new fuel filter because the fuel tank is empty. Refer to Replacing the Fuel Filter.

5. Install the fuel line onto the fuel filter. Slide the hose clamp close to the valve to secure the fuel line.

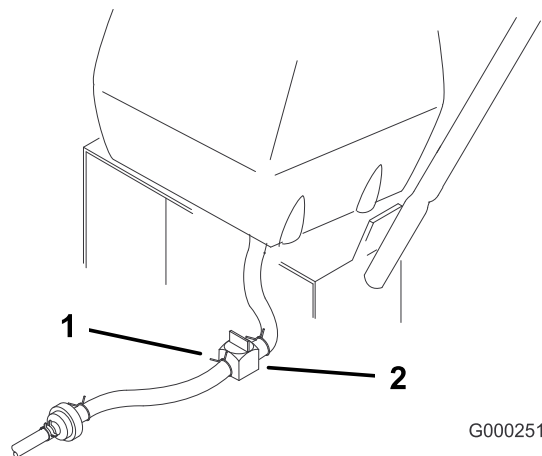

Figure 31

1. Fuel shut-off valve
2. Clamp

Replacing the Fuel Filter

Service Interval: Every 200 hours/Yearly (whichever comes first)

Never install a dirty filter if it is removed from the fuel line.

Note: Note how the fuel filter is installed.

Note: Wipe up any spilled fuel.

1. Disengage the PTO and set the parking brake.
2. Stop the engine, remove the key, and wait for all moving parts to stop before leaving the operating position.
3. Close fuel shut-off valve at fuel tank (Figure 31).

Note: Remove the fuel line from the fuel valve that is closest to the engine.

4. Squeeze the ends of the hose clamps together and slide them away from the filter (Figure 32).

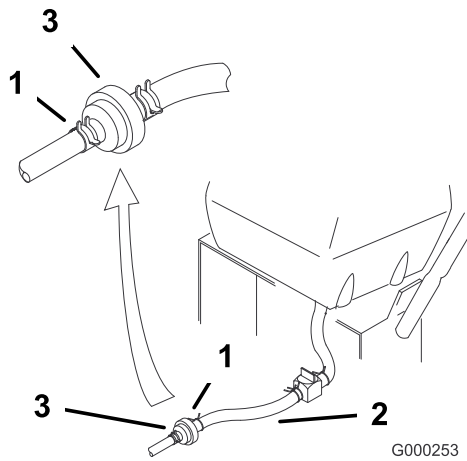

Figure 32

1. Hose clamp
2. Fuel line
3. Filter

5. Remove the filter from the fuel lines.
6. Install a new filter and move the hose clamps close to the filter.
7. Open fuel shut-off valve at fuel tank (Figure 31).
8. Check for fuel leaks and repair if needed.

Electrical System Maintenance

Servicing the Fuse

The electrical system is protected by a fuse. It requires no maintenance. If the fuse blows check component or circuit for malfunction or short. To replace fuse pull out on the fuse (Figure 33) to remove or replace it.

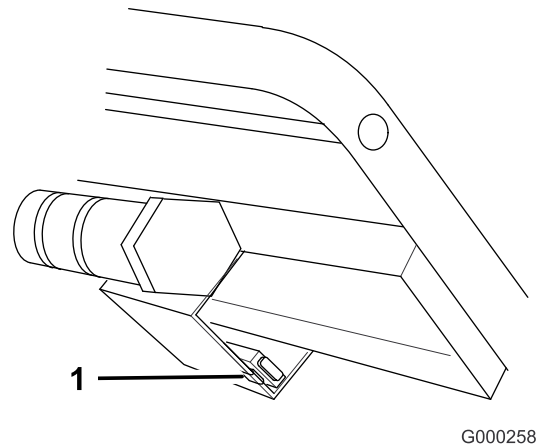

Figure 33

1. Fuse, 7.5 amp, blade type

Drive System Maintenance

Adjusting the Control Bar

1. Check the gap between upper control bar and fixed bar with wheel drive fully engaged. Ensure the gap is approximately 25-32 mm (1 to 1-1/4 inch) (Figure 34).

Note: The upper control bar and fixed bar must be parallel when the upper control bar is in the engaged, drive, neutral, or brake positions.

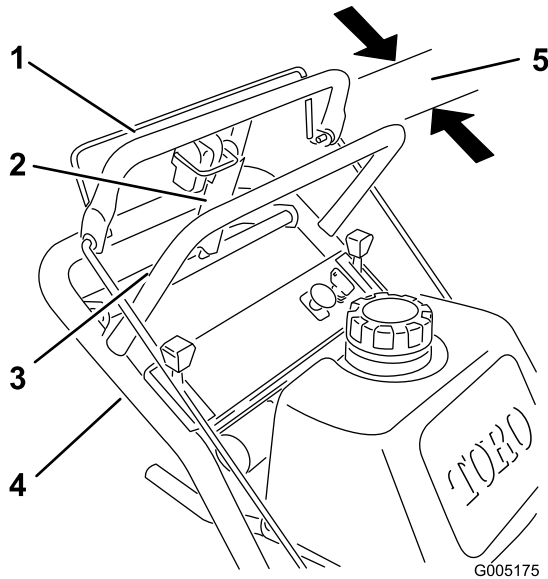

Figure 34

- | | |
|------------------------|-----------------------------------|
| 1. Upper control bar | 4. Handle |
| 2. Parking brake lever | 5. 25-32 mm (1 to 1-1/4 inch) gap |
| 3. Fixed control bar | |

2. Check the operation. If adjustment is required, remove hairpin cotter, washer and clevis pin securing control rod fitting to idler bracket (Figure 35).
3. Thread the rod fitting up or down on the rod until the proper position is attained and install the rod fitting to the idler bracket with the clevis pin, washer and hairpin cotter.

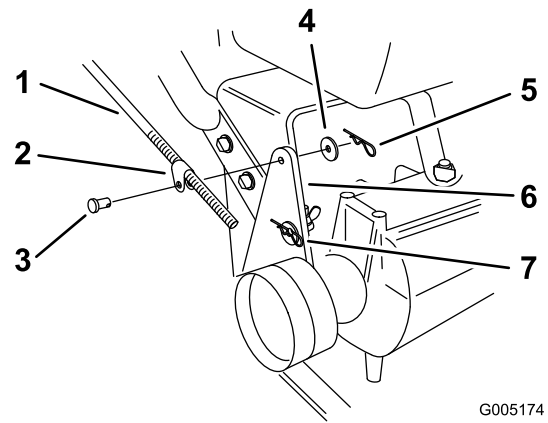

Figure 35

- | | |
|----------------------------|-----------------------|
| 1. Control rod and fitting | 5. Washer |
| 2. 89 mm (3-1/2 inch) | 6. Hairpin cotter pin |
| 3. Idler bracket | 7. Rod fitting |
| 4. Clevis pin | 8. Hole F |

Checking the Tire Pressure

Service Interval: Every 50 hours/Monthly (whichever comes first)

Maintain the air pressure in the rear tires at 12-14 psi (83-97 kPa). Uneven tire pressure can cause an uneven cut (Figure 36).

Note: The front tires are semi-pneumatic tires and do not require air pressure maintenance.

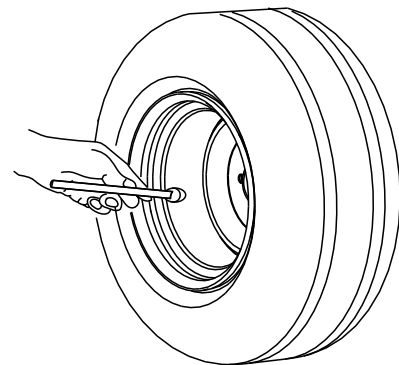

G001055

Figure 36

Replacing the Caster Wheel Fork Bushings

The caster wheel forks are mounted in bushings pressed into the top and bottom of the carrier frame mounting pivot tubes. To check the bushings, move the caster forks back and forth and side-to-side. If a caster fork is loose, the bushings are worn and must be replaced.

1. Raise the cutting unit so the caster wheels are off the floor, then support the front of the mower with jack stands.
2. Remove the locking pin and spacer(s) from the top of the caster wheel fork (Figure 37).

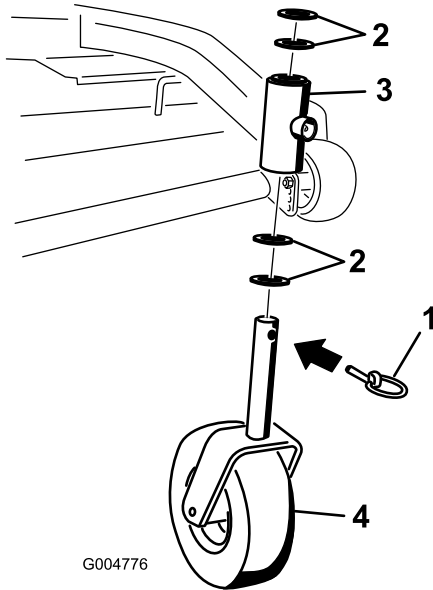

Figure 37

- | | |
|----------------|-----------------------------|
| 1. Locking Pin | 3. Carrier frame pivot tube |
| 2. Spacers | 4. Caster wheel |

3. Pull the caster wheel fork out of the mounting tube, leaving the spacer(s) on the bottom of the fork. Remember the location of the spacers on each fork to ensure correct installation, and to maintain a level deck.
4. Insert a pin punch into the mounting tube and carefully drive out the bushings (Figure 38). Clean the inside of the mounting tube.

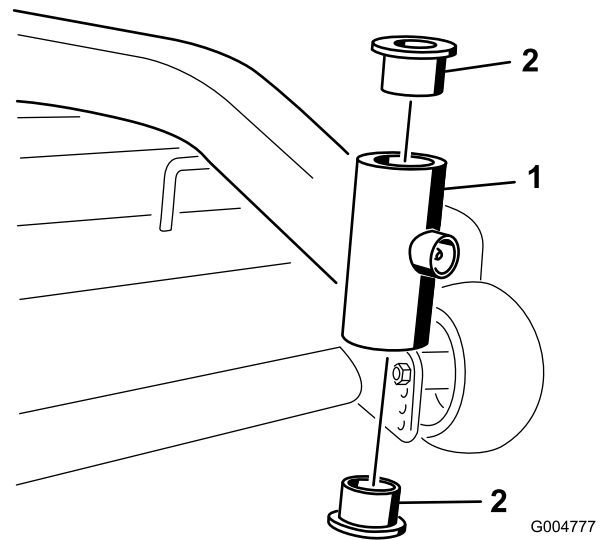

Figure 38

- | | |
|------------------|------------|
| 1. Mounting Tube | 2. Bushing |
|------------------|------------|

5. Grease the inside and outside of the new bushings. Use a hammer and flat plate to carefully drive the bushings into the pivot tubes.
6. Inspect the caster wheel fork for wear and replace if necessary (Figure 37).
7. Slide the caster wheel fork through the bushings in the mounting tube. Replace the spacer(s) onto the fork and secure with the retaining ring (Figure 37).

Important: The inside diameter of the bushings may collapse slightly when installed. If the caster wheel fork does not slide into the new bushings, ream both bushings to an inside diameter of 29 mm (1.126 inch).

8. Grease the fitting on the carrier frame pivot tubes using No. 2 general purpose lithium base or molybdenum base grease.

Servicing the Caster Wheel and Bearings

The caster wheels rotate on a roller bearing supported by a spanner bushing. If the bearing is kept well lubricated, wear will be minimal. Failure to keep the bearing well lubricated will cause rapid wear. A wobbly caster wheel usually indicates a worn bearing.

1. Remove the locknut and wheel bolt holding the caster wheel to the caster fork (Figure 39).

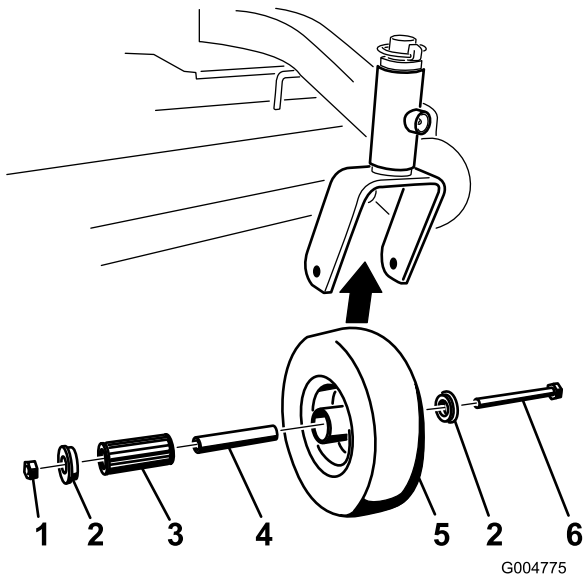

Figure 39

- | | |
|-------------------|--------------------|
| 1. Locknut | 4. Spanner Bushing |
| 2. Cap | 5. Wheel |
| 3. Roller Bearing | 6. Bushing |

4. Check each slot again and make slight adjustments until the feeler gauge between the rotor and armature with very slight contact between them.

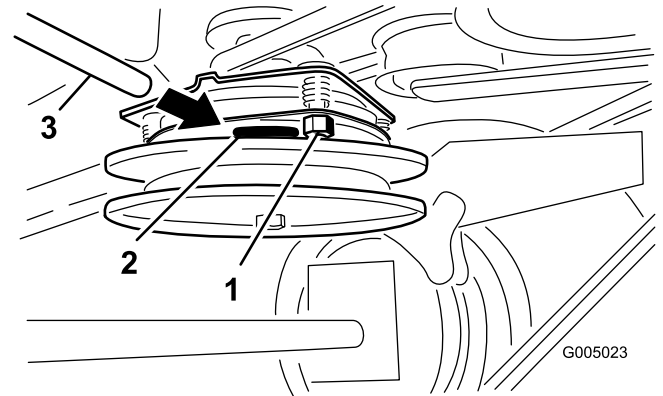

Figure 40

- | | |
|------------------|-----------------|
| 1. Adjusting nut | 3. Feeler gauge |
| 2. Slot | |

2. Remove one bushing, then pull the spanner bushing and roller bearing out of the wheel hub (Figure 39).
3. Remove the other bushing from the wheel hub and clean any grease and dirt from the wheel hub (Figure 39).
4. Inspect the roller bearing, bushings, spanner bushing and inside of the wheel hub for wear. Replace any defective or worn parts (Figure 39).
5. To assemble, place one bushing into the wheel hub. Grease the roller bearing and spanner bushing and slide them into the wheel hub. Place the second bushing into the wheel hub (Figure 39).
6. Install the caster wheel into the caster fork and secure with the wheel bolt and locknut. Tighten the locknut until the spanner bushing bottoms against the inside of the caster forks (Figure 39).
7. Grease the fitting on the caster wheel.

Adjusting the Electric Clutch

The clutch is adjustable to ensure proper engagement and proper braking.

1. Insert a 0.381–0.533 mm (0.015–0.021 inch) feeler gauge through one inspection slot in the side of the assembly. Make sure it is between the armature and the rotor friction surfaces.
2. Tighten the lock nuts until there is slight binding on the feeler gauge but it can be moved easily within the air gap (Figure 40).
3. Repeat this for the remaining slots.

Cooling System Maintenance

Cleaning the Air Intake Screen

Before each use remove any build-up of grass, dirt or other debris from the cylinder and cylinder head cooling fins, air intake screen on flywheel end, and carburetor-governor levers and linkage. This will help insure adequate cooling and correct engine speed and will reduce the possibility of overheating and mechanical damage to the engine.

Brake Maintenance

Servicing the Brakes

Service Interval: Before each use or daily

Check brakes on both a level surface and slope.

Always set the parking brake when you stop the machine or leave it unattended. If the parking brake does not hold securely, an adjustment is required.

Checking the Brakes

1. Park the machine on a level surface, disengage the PTO.
2. Stop the engine, remove the key, and wait for all moving parts to stop before leaving the operating position.
3. Apply the parking brake. The wheels must lock when you try to push the machine forward.
4. If the wheels do not lock, adjust the brakes. Refer to Adjusting the Brakes.
5. Release the brake and press upper control bar very lightly, approximately 13 mm (1/2 inch). The wheels should rotate freely, if not; refer to Adjusting the Brakes.

Adjusting the Brakes

The brake lever is on the upper control bar. If the parking brake does not hold securely, an adjustment is required.

Note: For the initial adjustment, adjust the wing nut until it is 32 mm (1-1/4 inches) from the top of the rod (Figure 41).

1. Park the machine on a level surface, disengage the PTO, and set the parking brake.
2. Stop the engine, remove the key, and wait for all moving parts to stop before leaving the operating position.
3. Check the brake before you adjust it; refer to Checking the Brakes.
4. Release the parking brake; refer to Releasing the Parking Brake in Operation.
5. Remove the plastic cover over the brake lever.
6. To adjust the brake, remove the hair pin cotter and washer from the brake lever and trunnion (Figure 41).

Belt Maintenance

Checking the Belts

Service Interval: Every 50 hours/Monthly (whichever comes first)

Look for dirt, wear, cracks and signs of overheating.

Replacing the Traction Drive Belt

1. Remove the plastic cover over the idler bracket.
2. Remove the top bolt securing idler support and idler bracket to rear frame (Figure 42).

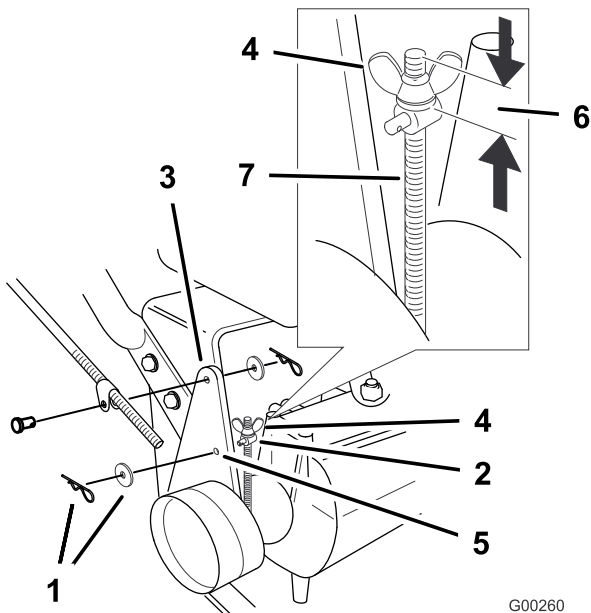

Figure 41

G00260

- | | |
|------------------------------|---|
| 1. Hairpin cotter and washer | 5. Hole F |
| 2. Trunnion | 6. Initial adjustment of 32 mm (1-1/4 inch) |
| 3. Brake lever | 7. Rod |
| 4. Wing nut | |
-
7. Rotate the wing nut clockwise to increase the braking pressure.
 8. Rotate the wing nut counterclockwise to decrease the braking pressure.
 9. Install the trunnion into hole F (Figure 41). Tighten the wing nut.
 10. Secure trunnion to brake lever with washer and hair pin cotter (Figure 41).
 11. Check the brake operation again; refer to Checking the Brakes.
- Important:** With the parking brake released, the rear wheels must rotate freely when you push the mower. If brake action and free wheel rotation cannot be achieved contact your service dealer immediately.
12. Install the plastic cover over the brake lever.

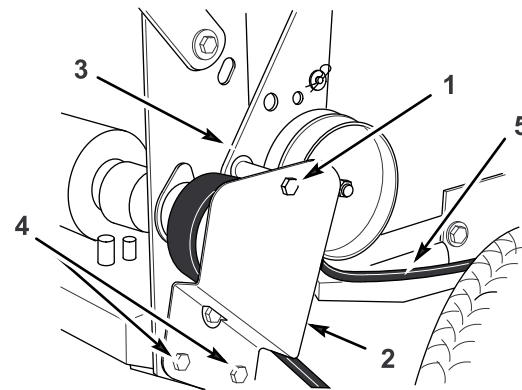

Figure 42

G000263

- | | |
|------------------|------------------------|
| 1. Top bolt | 4. Bottom bolt |
| 2. Idler bracket | 5. Traction drive belt |
| 3. Idler support | |

-
3. Loosen bottom two mounting screws enough to allow belt to pass between drive pulley and idler support (Figure 42).
 4. Raise the wheel off the ground, to allow the belt to be removed, and remove the belt.
 5. Install a new belt.
 6. Install the top bolt securing the idler support and idler bracket to the rear frame (Figure 42).
 7. Tighten the bottom two mounting screws enough to allow the belt to pass between the drive pulley and idler support (Figure 42).
 8. Install the plastic cover over the idler bracket.

Replacing the Transmission Belt

1. Disengage the PTO and set the parking brake.
2. Stop the engine, remove the key, and wait for all moving parts to stop before leaving the operating position.
3. Remove the panel from the bottom of the machine.

4. Remove PTO drive belt. Refer to Replacing the PTO Drive Belt in the Belt Maintenance (page 32).
5. Raise the front of the machine and hold with jack stands.
6. Disconnect clutch wire connector from wire harness.
7. Disconnect clutch retainer from the engine deck (Figure 43).

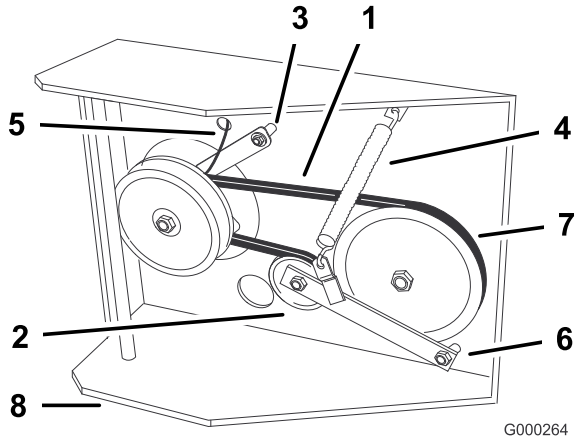

Figure 43

- | | |
|----------------------|--------------------------|
| 1. Transmission belt | 5. Clutch wire connector |
| 2. Idler pulley | 6. Pivot bolt |
| 3. Clutch retainer | 7. Drive pulley |
| 4. Tension spring | 8. Engine deck |

8. Unhook tension spring from side of frame (Figure 43).
9. Loosen pivot bolt enough to remove traction belt from the drive pulley and clutch.
10. Install new belt around clutch and drive pulley.
11. Torque pivot bolt to 47-54 N-m (35-40 ft-lb). Install tension spring between idler arm and frame bracket (Figure 43).
12. Install clutch retainer to the engine deck (Figure 43).
13. Connect clutch wire connector to wire harness.
14. Install PTO drive belt.
15. Install the panel to the bottom of the machine.

Replacing the Mower Belt

Squealing when the belt is rotating, blades slipping when cutting grass, frayed belt edges, burn marks and cracks are signs of a worn deck belt. Replace the deck belt if any of these conditions are evident.

1. Disengage the PTO and set the parking brake.
2. Stop the engine, remove the key, and wait for all moving parts to stop before leaving the operating position.
3. Remove the carrier frame cover.
4. Remove the belt cover with bolts.

5. Remove the PTO drive belt. Refer to Replacing the PTO Drive Belt.
6. Disconnect the idler arm spring to relieve tension on the idler arm and idler pulley, then remove the worn mower belt (Figure 44).
7. Install the new mower belt around the two outside spindle pulleys, the idler pulley, and in the lower groove of the double spindle pulley (Figure 44).
8. Connect the idler arm spring (Figure 44).
9. Install the PTO drive belt. Refer to Replacing the PTO Drive Belt.
10. Adjust the belt guide an 3 mm (1/8 inch) from the belt (Figure 44).
11. Install the belt cover onto the cutting unit and screw in the bolts.
12. Install the carrier frame cover onto the cutting unit.

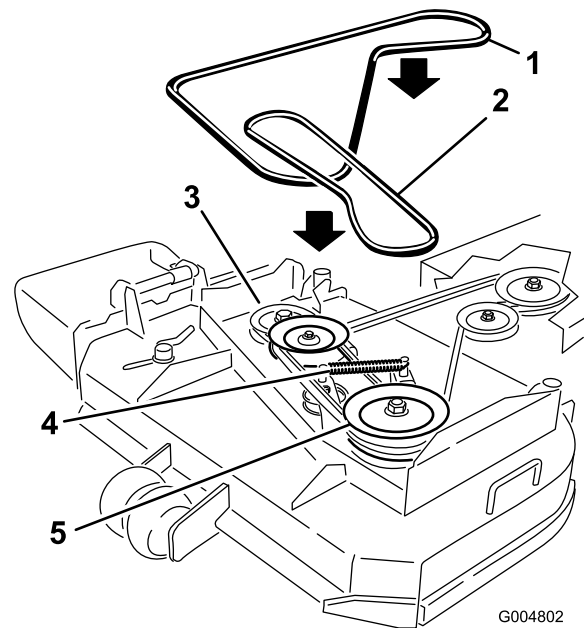

Figure 44

- | | |
|----------------------|----------------------|
| 1. Mower deck belt | 4. Idler arm spring |
| 2. PTO Drive Belt | 5. Drive belt pulley |
| 3. Drive belt pulley | |

Replacing the PTO Drive Belt

Squealing when the belt is rotating, blades slipping when cutting grass, frayed belt edges, burn marks and cracks are signs of a worn drive belt. Replace the drive belt if any of these conditions are evident.

1. Disengage the PTO and set the parking brake.
2. Stop the engine, remove the key, and wait for all moving parts to stop before leaving the operating position.
3. Remove the carrier frame cover.

4. Remove the belt cover.
5. Remove the heat shield from the engine deck and carrier frame.
6. Roll the belt off of the center pulley on the mower deck (Figure 45). Use caution when removing the belt as tension will increase because of the spring loaded idler pulley.
7. Remove the belt from the engine pulley and the spring loaded idler pulley (Figure 45).
8. Install the new belt onto the engine pulley and spring loaded idler pulley (Figure 45).
9. Roll the belt onto the center pulley on the mower deck (Figure 45). Use caution when install the belt as tension will increase because of the spring loaded idler pulley.
10. Install the heat shield to the engine deck and carrier frame.
11. Install the belt cover onto the cutting unit and screw in the bolts.
12. Install the carrier frame cover onto the carrier frame.

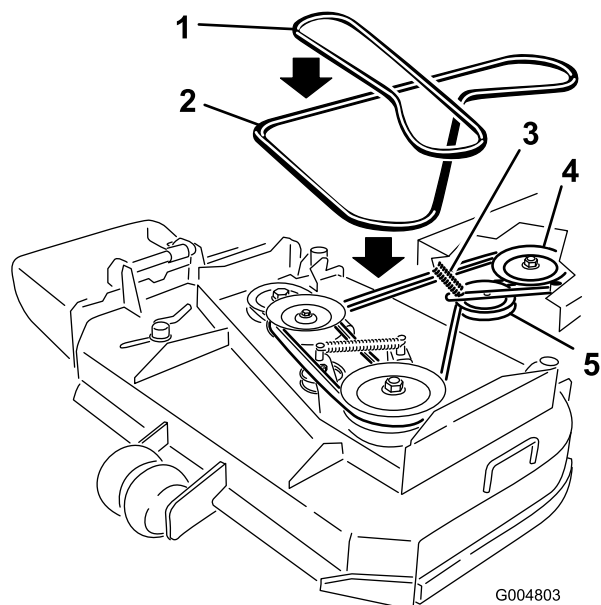

Figure 45

- | | |
|-------------------------|------------------|
| 1. Mower deck belt | 4. Clutch pulley |
| 2. PTO Drive Belt | 5. Idler pulley |
| 3. Idler arm and spring | |

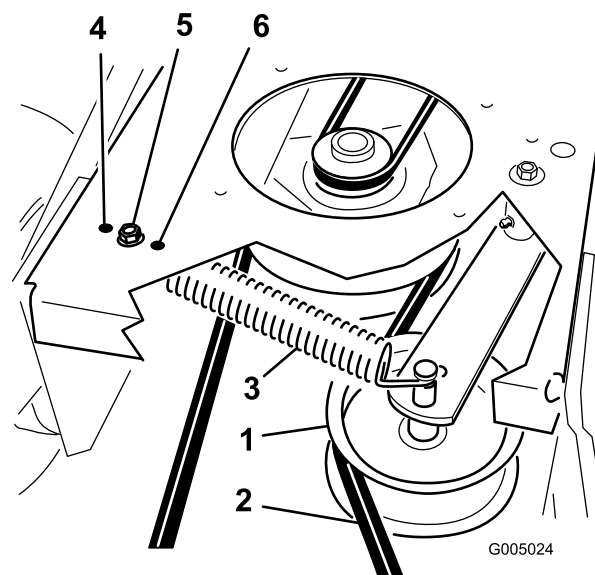

Figure 46

- | | |
|--------------------------------|--|
| 1. PTO drive belt idler pulley | 4. Most tension for worn belts |
| 2. PTO drive Belt | 5. Medium tension for normal belt conditions |
| 3. Idler spring | 6. Least tension for new belts |

Adjusting the PTO Drive Belt Idler Spring Anchor

The position of the PTO idler can be adjusted to increase or decrease belt tension.

Use Figure 46 for the idler position options.

Mower Deck Maintenance

Servicing the Cutting Blades

To ensure a superior quality of cut, keep the blades sharp. For convenient sharpening and replacement, you may want to keep extra blades on hand.

⚠ WARNING

A worn or damaged blade can break, and a piece of the blade could be thrown into the operator's or bystander's area, resulting in serious personal injury or death.

- Inspect the blades periodically for wear or damage.
- Replace a worn or damaged blade.

Before Inspecting or Servicing the Blades

Park the machine on a level surface, disengage the blades and set the parking brake. Turn the ignition key to off. Remove the key and disconnect the spark plug wires from the spark plugs.

Inspecting the Blades

Service Interval: Before each use or daily

1. Inspect the cutting edges (Figure 47). If the edges are not sharp or have nicks, remove and sharpen the blades. Refer to Sharpening the Blades.

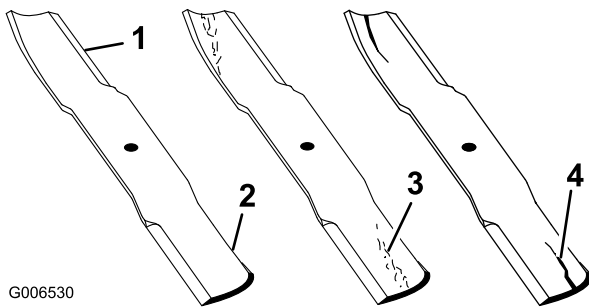

Figure 47

1. Cutting Edge
2. Sail
3. Wear/slot forming in curved area
4. Crack in the curved area

2. Inspect the blades, especially the curved area (Figure 47). If you notice any cracks, wear, or a slot forming in this area (item 3. in Figure 47), immediately install a new blade.

Checking for Bent Blades

1. Disengage the PTO, move the motion control levers to the neutral locked position and set the parking brake.
2. Stop the engine, remove the key, and wait for all moving parts to stop before leaving the operating position.
3. Rotate the blades until the ends face forward and backward. Measure from a level surface to the cutting edge, position **A**, of the blades (Figure 48). Note this dimension.

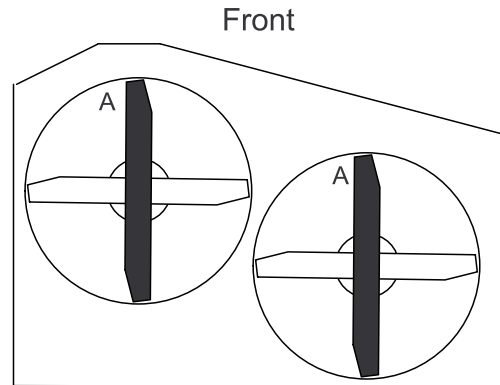

G000288

Figure 48

4. Rotate the opposite ends of the blades forward.
5. Measure from a level surface to the cutting edge of the blades at the same position as in step 3 above. The difference between the dimensions obtained in steps 3 and 4 must not exceed 3 mm (1/8 inch). If this dimension exceeds 3 mm (1/8 inch), the blade is bent and must be replaced; refer to Removing the Blades and Installing the Blades.

⚠ WARNING

A blade that is bent or damaged could break apart and could seriously injure or kill you or bystanders.

- Always replace bent or damaged blade with a new blade.
- Never file or create sharp notches in the edges or surfaces of blade.

Removing the Blades

Blades must be replaced if a solid object is hit, if the blade is out of balance or is bent. To ensure optimum performance and continued safety conformance of the machine, use genuine Toro replacement blades. Replacement blades made by other manufacturers may result in non-conformance with safety standards.

1. Hold the blade end using a rag or thickly-padded glove.

- Remove the blade bolt, curved washer, blade stiffener, and blade from the spindle shaft (Figure 49).

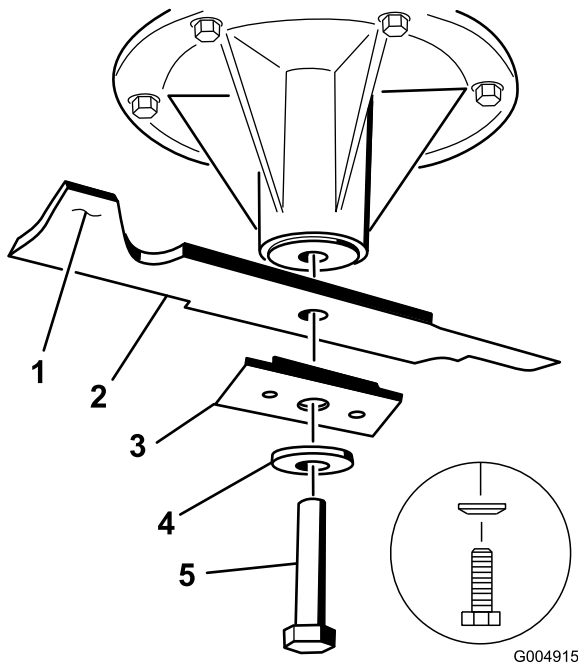

Figure 49

- | | |
|-----------------------|------------------|
| 1. Sail Area of Blade | 4. Curved washer |
| 2. Blade | 5. Blade Bolt |
| 3. Blade stiffener | |

Sharpening the Blades

- Use a file to sharpen the cutting edge at both ends of the blade (Figure 50). Maintain the original angle. The blade retains its balance if the same amount of material is removed from both cutting edges.

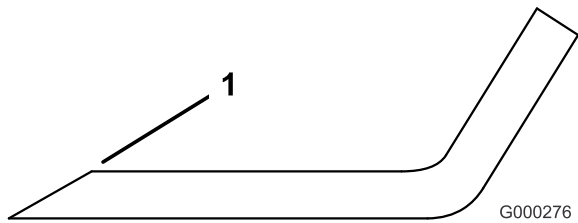

Figure 50

- Sharpen at original angle

- Check the balance of the blade by putting it on a blade balancer (Figure 51). If the blade stays in a horizontal position, the blade is balanced and can be used. If the blade is not balanced, file some metal off the end of the sail area only (Figure 47). Repeat this procedure until the blade is balanced.

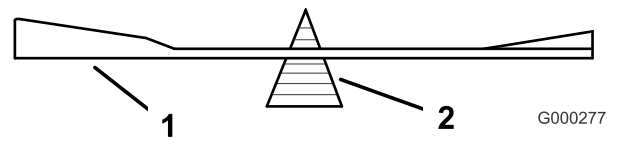

Figure 51

- | | |
|----------|-------------|
| 1. Blade | 2. Balancer |
|----------|-------------|

Installing the Blades

- Install the blade onto the spindle shaft (Figure 49).

Important: The sail part of the blade must be pointing upward, toward the inside of the mower to ensure proper cutting (Figure 49).
- Install the blade, stiffener, curved washer, and blade bolt (Figure 49).
- Torque the blade bolt to 115-140 N-m (85-110 ft-lb).

Correcting the Mower Quality of Cut

If one deck blade cuts lower than the other, correct as follows.

Note: Tire air pressure is critical in these procedures. Make sure all tires have correct pressure.

- Disengage the PTO and set the parking brake.
- Stop the engine, remove the key, and wait for all moving parts to stop before leaving the operating position. Disconnect the spark plug wire(s) from the spark plug(s).
- Adjust the tire pressure in the rear tires to specifications; refer to Drive System Maintenance (page 28).
- Check that the blades and spindle shafts are not bent. Refer to Checking for Bent Blades.
- Set the height-of-cut to the 101.6 mm (4 inch) position. Refer to Adjusting the Height-Of-Cut in Operation.
- Perform the steps in the following sections Frame Set Up, Checking Front-to-Rear Pitch, and Checking Side-to-Side Leveling.

Frame Set Up

Checking the Carrier Frame and Engine Deck Alignment

Note: Misalignment can cause excess wear on the PTO drive belt.

- Disengage the PTO and set the parking brake.
- Stop the engine, remove the key, and wait for all moving parts to stop before leaving the operating position.
- Place a long straight edge on top of the engine deck as shown in Figure 52.

4. At the carrier frame cross channel, measure the height at location **A** (Figure 52). This measurement must be 33 mm (1-5/16 inch), plus or minus a 6 mm (1/4 inch).
5. If the height at location **A** is not correct, adjustment is needed.
6. Loosen the carrier frame mounting bolts on both sides of the machine (Figure 52).
7. Align the carrier frame and engine deck to match 33 mm (1-5/16 inch), plus or minus a 6 mm (1/4 inch) at location **A** (Figure 52).
8. Tighten the carrier frame mounting bolts on both sides of the machine.

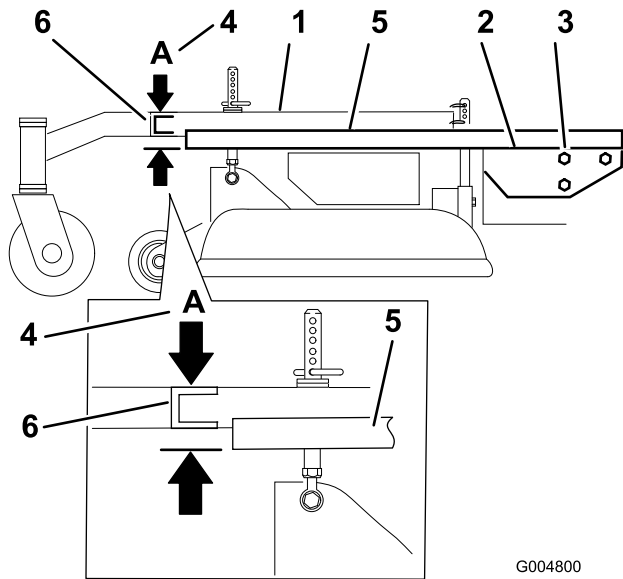

Figure 52

- | | |
|---------------------------------|--|
| 1. Carrier Frame | 4. Location A, 33 mm (1-5/16 inch) \pm 6 mm (1/4 inch) |
| 2. Top of engine deck | 5. Straight edge |
| 3. Carrier frame mounting bolts | 6. Carrier frame cross channel |

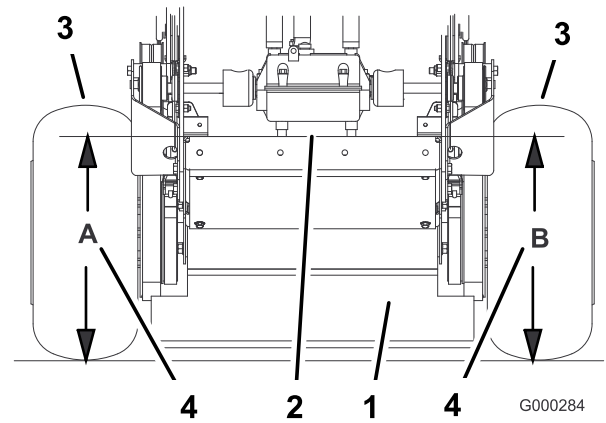

Figure 53

- | | |
|-------------------------|---|
| 1. Back view of machine | 3. Tires |
| 2. Top of engine deck | 4. Same height at locations A and B |
-
5. Measure engine deck height at location **B** (Figure 53).
 6. If the height at location **A** and **B** are not the same, change tire pressure slightly to make them the same.

Checking the Engine Deck Height

1. Disengage the PTO and set the parking brake.
2. Stop the engine, remove the key, and wait for all moving parts to stop before leaving the operating position.
3. Adjust the tire pressure in the rear tires to specifications; refer to Drive System Maintenance (page 28) .
4. Measure engine deck height at location **A** (Figure 53).

Checking the Carrier Frame Front-to-Rear Pitch

The carrier frame must have a pitch between 3 mm (1/8 inch) to 9 mm (3/8 inch) over the length of 61 cm (24 inches) on the carrier frame (Figure 54).

1. Measure out 61 cm (24 inches) on the carrier frame (Figure 54).

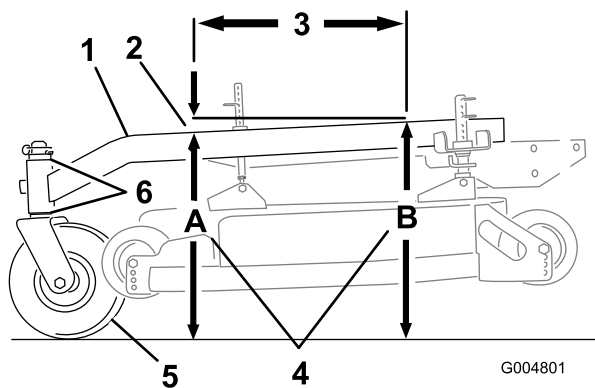

Figure 54

- | | |
|---|--|
| 1. Carrier Frame | 4. Height at locations A and B |
| 2. 6-10 mm (1/4-3/8 inch) pitch over 61 cm (24 inch) length | 5. Caster Wheel |
| 3. 61 cm (24 inches) | 6. Caster spacers |

2. Measure carrier frame height at location **A** (Figure 54).
3. Measure carrier frame height at location **B** (Figure 54).
4. The height at location **A** must be a 6-10 mm (1/4-3/8 inch) lower than location **B** (Figure 54).
5. If the carrier frame is not correct, move caster spacers to make it a 6-10 mm (1/4-3/8 inch) pitch (Figure 54). Move spacers from top or bottom to make the correct pitch.
6. The tire pressure may also be adjusted slightly to make a 6 mm (1/4 inch) pitch.

Checking the Carrier Frame Side-to-Side Height

Make sure the carrier frame is parallel side-to-side from the ground.

1. Disengage the PTO and set the parking brake.
2. Stop the engine, remove the key, and wait for all moving parts to stop before leaving the operating position.
3. Adjust the tire pressure in the rear tires to specifications; refer to Drive System Maintenance (page 28) .
4. Measure carrier frame height at location **A** (Figure 55).
5. Measure carrier frame height at location **B** (Figure 55).
6. If the carrier frame height is not the same move spacers from top or bottom of caster wheel, to make it level.

The tire pressure may also be adjusted slightly to make it level.

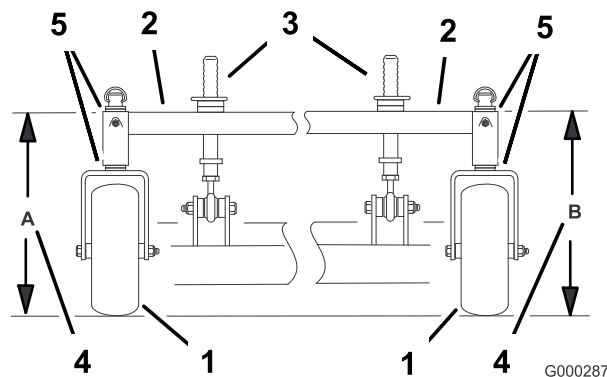

Figure 55

- | | |
|-----------------------------|---|
| 1. Caster Wheel | 4. Same height at locations A and B |
| 2. Carrier Frame | 5. Caster spacers |
| 3. Front height-of-cut pins | |

Checking the Mower Deck Front-to-Rear Pitch

1. Adjust the tire pressure in the rear tires to specifications; refer to Drive System Maintenance (page 28) .
2. Position one blade front-to-rear. Measure at **A** and **B** locations from a level surface to the cutting edge of the blade tips (Figure 56).
3. Ensure the mower blade is 6 mm (1/4 inch) lower in front at **A** than in the rear at **B**. Rotate blades and repeat for other blades. If it is not correct, proceed to Changing the Deck Front-to-Rear Pitch.

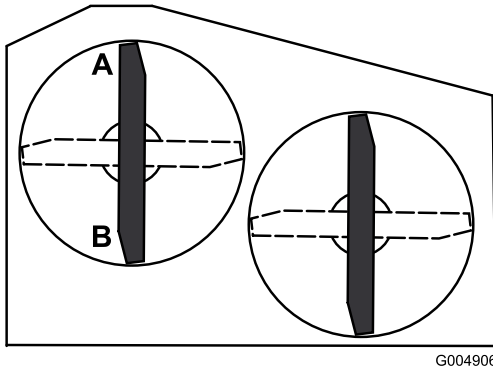

Figure 56

G004906

Changing the Mower Deck Front-to-Rear Pitch

Changing the front-to-rear pitch is done by adjusting the front height-of-cut posts.

1. To change the front-to-rear pitch, the front height-of-cut posts can be adjusted (Figure 57).

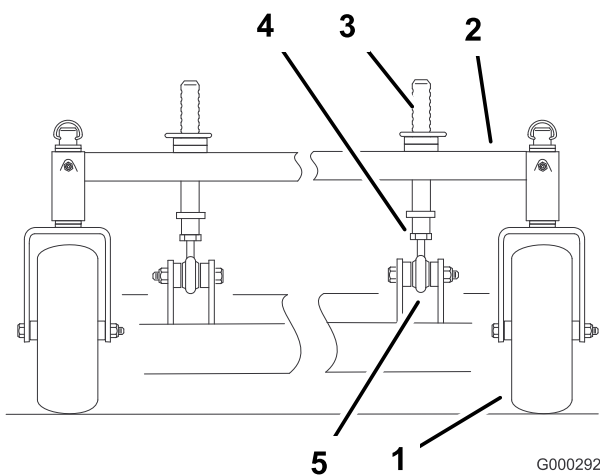

Figure 57

G000292

- | | |
|-----------------------------|---------------|
| 1. Caster Wheel | 4. Jam nut |
| 2. Carrier Frame | 5. Ball joint |
| 3. Front height-of-cut pins | |

2. To raise the front of the deck, loosen jam nut and rotate the front pin clockwise (Figure 57).
3. To lower the front of the deck, loosen jam nut and rotate the front pin counter clockwise (Figure 57).
4. Position the blades front-to-rear. Check the front-to-rear pitch and adjust if needed.
5. Check the side-to-side leveling of the cutting unit.
6. Tighten the jam nuts (Figure 57).

Checking the Mower Deck Side-to-Side Height

1. Adjust the rear tire pressure to specifications; refer to Drive System Maintenance (page 28) .
2. Position the blades side-to-side. Measure at **C** and **D** locations from a level surface to the cutting edge of blade tips (Figure 58).

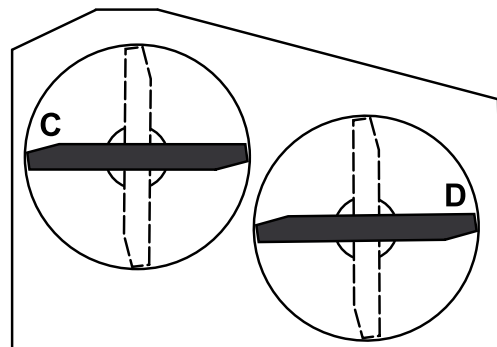

Figure 58

G004907

3. Ensure the difference between measurements **C** and **D** is no more than 6 mm (1/4 inch).

Changing the Mower Deck Side-to-Side Height

Changing the side-to-side height is done by adjusting the rear tire pressure and caster spacers.

1. Change the rear tire pressure. Do this to the corresponding side that needs adjustment.
2. Adjust the caster spacer.
3. Recheck the front-to-rear pitch and side to side leveling of the cutting unit.

Matching Height of Cut

1. Check the rear tire pressure.
2. Set the height-of-cut to the 101.6 mm (4 inch) position following the height-of-cut decal.
3. With the machine on level surface, position one blade front-to-rear. Measure at **A** and from level surface to the cutting edge of the blade tips (Figure 59).

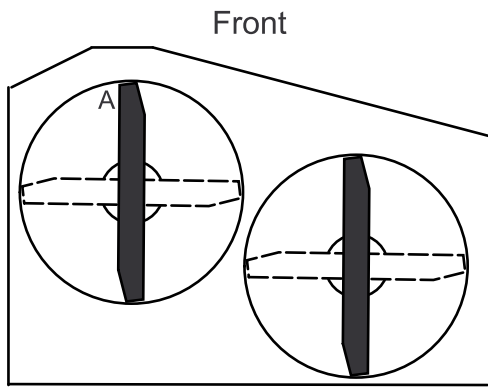
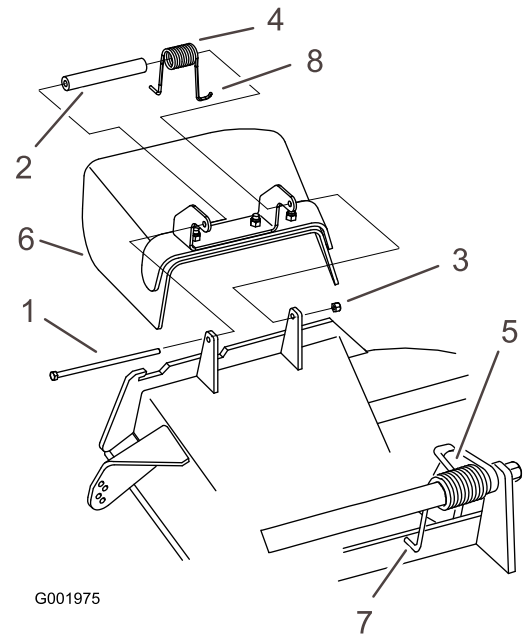

Figure 59

G000296



G001975

Figure 60

- | | |
|------------|-------------------------|
| 1. Bolt | 5. Spring installed |
| 2. Spacer | 6. Grass Deflector |
| 3. Locknut | 7. J hook end of spring |
| 4. Spring | |

4. Ensure the measurement is 101.6 mm (4 inch).
5. If it does not measure correctly:
 - A. Adjust the rear tire pressure.
 - B. Adjust the caster fork spacers.
 - C. Adjust the front mower deck support pins.
6. Check the carrier frame front-to-rear pitch.

Replacing the Grass Deflector

⚠ WARNING

An uncovered discharge opening could allow the lawn mower to throw objects in the operator's or bystander's direction and result in serious injury. Also, contact with the blade could occur.

Never operate the lawn mower unless you install a cover plate, a mulch plate, grass deflector or bagger.

1. Remove the locknut, bolt, spring and spacer holding the deflector to the pivot brackets (Figure 60). Remove the damaged or worn grass deflector.

2. Place the spacer and spring onto the grass deflector. Place one J end of the spring behind the deck edge.

Note: Make sure one J end of the spring is installed behind the deck edge before installing the bolt as shown in Figure 60.
3. Install the bolt and nut. Place one J hook end of the spring around the grass deflector (Figure 60).

Important: The grass deflector must be able to rotate. Lift the deflector up to the full open position and ensure that it rotates into the full down position.

Storage

Cleaning and Storage

1. Disengage the power take off (PTO), set the parking brake, and turn the ignition key to off. Remove the key.
2. Remove grass clippings, dirt, and grime from the external parts of the entire machine, especially the engine. Clean dirt and chaff from the outside of the engine's cylinder head fins and blower housing.
Important: You can wash the machine with mild detergent and water. Do not pressure wash the machine. Avoid excessive use of water, especially near the shift lever plate, and engine.
3. Check the brake; refer to Servicing the Brake in Brake Maintenance (page 31).
4. Service the air cleaner; refer to Servicing the Air Cleaner in Engine Maintenance (page 23).
5. Grease the machine; refer to Greasing and Lubrication in Lubrication (page 21).
6. Change the engine oil; refer to Servicing the Engine in Engine Maintenance (page 23).
7. Check the tire pressure; refer to Checking the Tire Pressure in Drive System Maintenance (page 28).
8. For long-term storage:
 - A. Add stabilizer/conditioner additive to fuel in the tank.
 - B. Run engine to distribute conditioned fuel through the fuel system (5 minutes).
 - C. Stop engine, allow to cool and drain the fuel tank; refer to Servicing the Fuel Tank in Fuel System Maintenance (page 26), or operate engine until it stops.
 - D. Restart engine and run until it stops. Repeat, on Choke until engine will not restart.
 - E. Dispose of fuel properly. Recycle as per local codes.
Note: Do not store stabilizer/conditioned gasoline over 90 days.
9. Remove the spark plug(s) and check its condition; refer to Servicing the Spark Plug in Engine Maintenance (page 23). With the spark plug(s) removed from the engine, pour two tablespoons of engine oil into the spark plug hole. Now use the starter to crank the engine and distribute the oil inside the cylinder. Install the spark plug(s). Do not install the wire on the spark plug(s).
10. Check and tighten all bolts, nuts, and screws. Repair or replace any part that is damaged or defective.
11. Paint all scratched or bare metal surfaces. Paint is available from your Authorized Service Dealer.
12. Store the machine in a clean, dry garage or storage area. Remove the key from the ignition switch and keep it in a memorable place. Cover the machine to protect it and keep it clean.

Troubleshooting

Problem	Possible Cause	Corrective Action
Engine will not start, starts hard, or fails to keep running.	<ol style="list-style-type: none"> 1. Fuel tank is empty. 2. Choke is not on. 3. Air cleaner is dirty. 4. Spark plug wire is loose or disconnected. 5. Spark plug is pitted, fouled, or the gap is incorrect. 6. Dirt in the fuel filter. 7. Dirt, water, or stale fuel is in the fuel system. 	<ol style="list-style-type: none"> 1. Fill fuel tank with gasoline. 2. Move the choke lever to choke position. 3. Clean or replace the air cleaner element. 4. Install wire on spark plug. 5. Install a new, correctly gapped spark plug. 6. Replace the fuel filter. 7. Contact an Authorized Service Dealer.
Engine loses power.	<ol style="list-style-type: none"> 1. Engine load is excessive. 2. Air cleaner is dirty. 3. Oil level in the crankcase is low. 4. Cooling fins and air passages under the engine blower housing are plugged. 5. Spark plug is pitted, fouled, or the gap is incorrect. 6. Vent hole in the fuel cap is plugged. 7. Dirt in the fuel filter. 8. Dirt, water, or stale fuel is in the fuel system. 	<ol style="list-style-type: none"> 1. Reduce the ground speed. 2. Service the air cleaner. 3. Add oil to the crankcase. 4. Remove the obstruction from the cooling fins and air passages. 5. Install a new, correctly gapped spark plug. 6. Clean or replace the fuel cap. 7. Replace the fuel filter. 8. Contact an Authorized Service Dealer.
Engine overheats.	<ol style="list-style-type: none"> 1. Engine load is excessive. 2. Oil level in the crankcase is low. 3. Cooling fins and air passages under the engine blower housing are plugged. 	<ol style="list-style-type: none"> 1. Reduce the ground speed. 2. Add oil to the crankcase. 3. Remove the obstruction from the cooling fins and air passages.
Machine does not drive.	<ol style="list-style-type: none"> 1. Shift lever is in neutral. 2. Traction belt is worn, loose or broken. 3. Traction belt is off a pulley. 4. Broken or missing idler spring. 	<ol style="list-style-type: none"> 1. Move shift lever to a drive gear position. 2. Change the belt. 3. Change the belt. 4. Replace the spring.
Abnormal vibration.	<ol style="list-style-type: none"> 1. Cutting blade(s) is/are bent or unbalanced. 2. Blade mounting bolt is loose. 3. Engine mounting bolts are loose. 4. Loose engine pulley, idler pulley, or blade pulley. 5. Engine pulley is damaged. 6. Blade spindle is bent. 	<ol style="list-style-type: none"> 1. Install new cutting blade(s). 2. Tighten the blade mounting bolt. 3. Tighten the engine mounting bolts. 4. Tighten the appropriate pulley. 5. Contact an Authorized Service Dealer. 6. Contact an Authorized Service Dealer.
Uneven cutting height.	<ol style="list-style-type: none"> 1. Blade(s) not sharp. 2. Cutting blade(s) is/are bent. 3. Mower is not level. 4. Mower pitch is wrong. 5. Underside of mower is dirty. 6. Tire pressure is not correct. 7. Blade spindle bent. 	<ol style="list-style-type: none"> 1. Sharpen the blade(s). 2. Install new cutting blade(s). 3. Level the mower side-to-side position. 4. Adjust the front-to-rear pitch. 5. Clean the underside of the mower. 6. Adjust the tire pressure. 7. Contact an Authorized Service Dealer.

Problem	Possible Cause	Corrective Action
Blades do not rotate.	<ol style="list-style-type: none"> 1. Drive belt is worn, loose or broken. 2. Drive belt is off pulley. 3. Deck belt is worn, loose or broken. 4. Deck belt is off pulley. 5. Broken or missing idler spring. 6. Electric clutch out of adjustment. 7. Clutch connector or wire damaged. 8. Damaged electric clutch. 9. Safety interlock system prevents blade rotation. 10. PTO switch is faulty. 	<ol style="list-style-type: none"> 1. Check the belt tension. 2. Install drive belt and check adjusting shafts and belt guides for correct position. 3. Install new deck belt. 4. Install deck pulley and check the idler pulley, idler arm and spring for correct position and function. 5. Replace the spring. 6. Adjust the clutch air gap. 7. Contact an Authorized Service Dealer. 8. Contact an Authorized Service Dealer. 9. Contact an Authorized Service Dealer. 10. Contact an Authorized Service Dealer.

Schematics

KAWASAKI GEAR M.S.

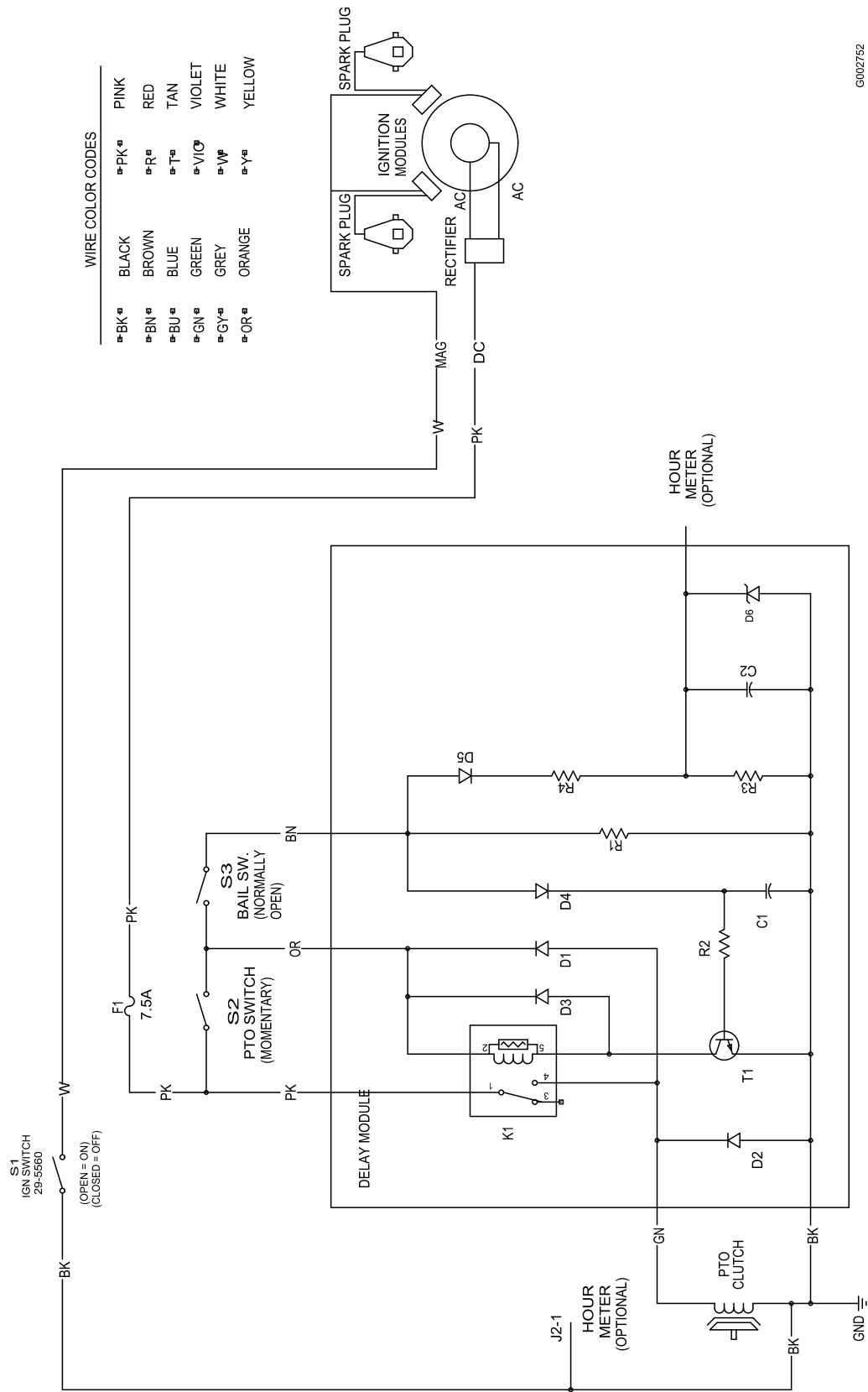

Electrical Schematic (Rev. A)

G002752

Notes:

Notes:

International Distributor List

Distributor:	Country:	Phone Number:	Distributor:	Country:	Phone Number:
Agrolanc Kft	Hungary	36 27 539 640	Maquiver S.A.	Colombia	57 1 236 4079
Balama Prima Engineering Equip.	Hong Kong	852 2155 2163	Maruyama Mfg. Co. Inc.	Japan	81 3 3252 2285
B-Ray Corporation	Korea	82 32 551 2076	Mountfield a.s.	Czech Republic	420 255 704 220
Casco Sales Company	Puerto Rico	787 788 8383	Mountfield a.s.	Slovakia	420 255 704 220
Ceres S.A.	Costa Rica	506 239 1138	Munditol S.A.	Argentina	54 11 4 821 9999
CSSC Turf Equipment (pvt) Ltd.	Sri Lanka	94 11 2746100	Norma Garden	Russia	7 495 411 61 20
Cyril Johnston & Co.	Northern Ireland	44 2890 813 121	Oslinger Turf Equipment SA	Ecuador	593 4 239 6970
Cyril Johnston & Co.	Republic of Ireland	44 2890 813 121	Oy Hako Ground and Garden Ab	Finland	358 987 00733
Equivier	Mexico	52 55 539 95444	Parkland Products Ltd.	New Zealand	64 3 34 93760
Femco S.A.	Guatemala	502 442 3277	Perfetto	Poland	48 61 8 208 416
ForGarder OU	Estonia	372 384 6060	Pratoverde SRL.	Italy	39 049 9128 128
G.Y.K. Company Ltd.	Japan	81 726 325 861	Prochaska & Cie	Austria	43 1 278 5100
Geomechaniki of Athens	Greece	30 10 935 0054	RT Cohen 2004 Ltd.	Israel	972 986 17979
Golf international Turizm	Turkey	90 216 336 5993	Riversa	Spain	34 9 52 83 7500
Guandong Golden Star	China	86 20 876 51338	Lely Turfcare	Denmark	45 66 109 200
Hako Ground and Garden	Sweden	46 35 10 0000	Solvvert S.A.S.	France	33 1 30 81 77 00
Hako Ground and Garden	Norway	47 22 90 7760	Spypros Stavrinides Limited	Cyprus	357 22 434131
Hayter Limited (U.K.)	United Kingdom	44 1279 723 444	Surge Systems India Limited	India	91 1 292299901
Hydroturf Int. Co Dubai	United Arab Emirates	97 14 347 9479	T-Markt Logistics Ltd.	Hungary	36 26 525 500
Hydroturf Egypt LLC	Egypt	202 519 4308	Toro Australia	Australia	61 3 9580 7355
Irrimac	Portugal	351 21 238 8260	Toro Europe NV	Belgium	32 14 562 960
Irrigation Products Int'l Pvt Ltd.	India	0091 44 2449 4387	Valtech	Morocco	212 5 3766 3636
Jean Heybroek b.v.	Netherlands	31 30 639 4611	Victus Emak	Poland	48 61 823 8369

European Privacy Notice

The Information Toro Collects

Toro Warranty Company (Toro) respects your privacy. In order to process your warranty claim and contact you in the event of a product recall, we ask you to share certain personal information with us, either directly or through your local Toro company or dealer.

The Toro warranty system is hosted on servers located within the United States where privacy law may not provide the same protection as applies in your country.

BY SHARING YOUR PERSONAL INFORMATION WITH US, YOU ARE CONSENTING TO THE PROCESSING OF YOUR PERSONAL INFORMATION AS DESCRIBED IN THIS PRIVACY NOTICE.

The Way Toro Uses Information

Toro may use your personal information to process warranty claims, to contact you in the event of a product recall and for any other purpose which we tell you about. Toro may share your information with Toro's affiliates, dealers or other business partners in connection with any of these activities. We will not sell your personal information to any other company. We reserve the right to disclose personal information in order to comply with applicable laws and with requests by the appropriate authorities, to operate our systems properly or for our own protection or that of other users.

Retention of your Personal Information

We will keep your personal information as long as we need it for the purposes for which it was originally collected or for other legitimate purposes (such as regulatory compliance), or as required by applicable law.

Toro's Commitment to Security of Your Personal Information

We take reasonable precautions in order to protect the security of your personal information. We also take steps to maintain the accuracy and current status of personal information.

Access and Correction of your Personal Information

If you would like to review or correct your personal information, please contact us by email at legal@toro.com.

Australian Consumer Law

Australian customers will find details relating to the Australian Consumer Law either inside the box or at your local Toro Dealer.



The Toro Total Warranty

Landscape
Contractor
Equipment (LCE)

Conditions and Products Covered

The Toro Company and its affiliate, Toro Warranty Company, pursuant to an agreement between them, jointly promise to the original purchaser to repair the Toro Products listed below if defective in materials or workmanship.

The following time periods apply from the date of purchase by the original owner:

Products	Warranty Period
Walk Behind Mowers	
53 cm Mowers – Residential use ¹	2 years
53 cm Mowers – Commercial use	1 year
76 cm Mowers – Residential use ¹	2 years
76 cm Mowers – Commercial use	1 year
Mid-Size Walk-Behind Mowers	2 years
• Engine	2 years ²
Grand Stand® Mowers	5 years or 1,200 hours ³
• Engine	2 years
• Frame	Lifetime (original owner only) ⁴
Z Master® 2000 Series Mowers	4 years or 500 hours ³
• Engine	2 years ²
• Frame	Lifetime (original owner only) ⁴
Z Master® 3000 Series Mowers	5 years or 1,200 hours ³
• Engine	2 years ²
• Frame	Lifetime (original owner only) ⁴
Z Master® 5000 and 6000 Series Mowers	5 years or 1,200 hours ³
• Engine	2 years ²
• Frame	Lifetime (original owner only) ⁴
Z Master® 7000 Series Mowers	5 years or 1,200 hours ³
• Engine	2 years ²
• Frame	Lifetime (original owner only) ⁴
All Mowers	
• Battery	2 years
• Attachments	2 years

¹Residential use means use of the product on the same lot as your home. Use at more than one location is considered commercial use and the commercial warranty would apply.

²Some engines used on Toro LCE Products are warranted by the engine manufacturer.

³Whichever occurs first.

⁴Lifetime Frame Warranty - If the main frame, consisting of the parts welded together to form the tractor structure that other components such as the engine are secured to, cracks or breaks in normal use, it will be repaired or replaced under warranty at no cost for parts and labor. Frame failure due to misuse or abuse and failure or repair required due to rust or corrosion are not covered.

This warranty includes the cost of parts and labor, but you must pay transportation costs.

Instructions for Obtaining Warranty Service

If you think that your Toro Product contains a defect in materials or workmanship, follow this procedure:

1. Contact your seller to arrange service of the product. If for any reason it is impossible for you to contact your seller, you may contact any Toro Authorized Distributor to arrange service.
2. Bring the product and your proof of purchase (sales receipt) to the Service Dealer.
3. If for any reason you are dissatisfied with the Service Dealer's analysis or with the assistance provided, contact us at:

RLC Customer Care Department

Toro Warranty Company
8111 Lyndale Avenue South
Bloomington, MN 55420-1196
001-952-948-4707

See attached Distributor List.

Owner Responsibilities

You must maintain your Toro Product by following the maintenance procedures described in the *Operator's Manual*. Such routine maintenance, whether performed by a dealer or by you, is at your expense.

Items and Conditions Not Covered

There is no other express warranty except for special emission system coverage and engine warranty coverage on some products. This express warranty does not cover the following:

- Cost of regular maintenance service or parts, such as filters, fuel, lubricants, oil changes, spark plugs, air filters blade sharpening or worn blades, cable/linkage adjustments, or brake and clutch adjustments
- Components failing due to normal wear
- Any product or part which has been altered or misused or neglected and requires replacement or repair due to accidents or lack of proper maintenance
- Pickup and delivery charges
- Repairs or attempted repairs by anyone other than an Authorized Toro Service Dealer
- Repairs necessary due to failure to follow recommended fuel procedure (consult *Operator's Manual* for more details)
 - Removing contaminants from the fuel system is not covered
 - Use of old fuel (more than one month old) or fuel which contains more than 10% ethanol or more than 15% MTBE
 - Failure to drain the fuel system prior to any period of non-use over one month

General Conditions

The purchaser is covered by the national laws of each country. The rights to which the purchaser is entitled with the support of these laws are not restricted by this warranty.