



**Count on it.**

**Parts Catalog**

**Versa Vac**

**Model No. 07053—Serial No. 260000001 and Up**



# Ordering Replacement Parts

To order replacement parts, please supply the part number, the quantity, and the description of each part desired.

## Understanding Reference Numbers

Each identified part in an illustration has a reference number. The reference number for a part also appears in the parts list, along with other information about the part.

This catalog uses two special reference number formats, one to indicate parts in a service assembly and another to indicate the quantity of a given part in an illustration.

## Service Assembly Reference Numbers

Parts in service assemblies have reference numbers in the form a:b. The a represents the reference number of the entire service assembly and the b represents a sequential number unique to each part within the service assembly.

For example, a wheel assembly might be identified by reference number 6, the tire by 6:1, the valve by 6:2, and the wheel by 6:3. When you order the assembly identified by reference number 6, you receive all parts identified by reference numbers 6:1, 6:2, and 6:3. However, you may also order any part individually. Reference numbers of this type appear in illustration and in parts lists.

## Reference Numbers Indicating Quantity

In an illustration, if a reference number indicates more than one part, the reference number has the form nX y. The n represents the quantity of the part, the X is the multiplication symbol, and the y represents the reference number.

For example, in an illustration, the reference number 2X 37 means that two of the parts identified by reference number 37 are indicated.

# List of Abbreviations

**AR:** as required

**ASM:** assembly

**BBC:** blade brake control

**BHTF:** button head thread forming

**CARR:** carriage

**CCW:** counter clockwise

**CW:** clockwise

**DEG:** degrees

**DPA:** Dual Point Adjustment

**ECM:** electronic control module

**EXT:** external

**FH:** flat head

**GA:** gauge

**HD:** heavy-duty

**HF:** hex flange

**HH:** hex head

**HHF:** hex head flange

**HHFTF:** hex head flange thread forming

**HJ:** hex jam

**HLH:** hex lag head

**HOC:** height-of-cut

**HSBH:** hex socket button head

**HSFH:** hex socket flat head

**HSH:** hex socket head

**HWH:** hex washer head

**HWHTF:** hex washer head thread forming

**HYD:** hydraulic

**LH:** left hand

**LP:** Liquefied Petroleum Gas

**LPG:** Liquefied Petroleum Gas

**NI:** nylon insert

**NPTF:** national pipe thread fine

**PFH:** phillips flat head

**PPH:** phillips pan head

**PPHTF:** phillips pan head thread forming

**PRH:** phillips round head

**PTH:** phillips truss head

**PTO:** power-take-off

**RH:** right hand

**ROPS:** roll-over protection system

**RRB:** rear roller brush

**SFH:** slotted fillister head

**SHH:** slotted hex head

**SHWH:** slotted hex washer head

**SPH:** slotted pan head

**SQH:** square head

**SRH:** slotted round head

**STD:** standard

**TAP:** self tapping

**TTH:** torx truss head

# Contents

Frame and Axle Assembly .....	4
Hydraulic Cylinder Assembly No. 107-1180.....	6
Impeller Assembly .....	7
Drive Assembly.....	8
Hydraulic Double Gear Pump Assembly No. 108-0856 .....	9
Power-Take-Off Shaft and Shield Assembly .....	10
Double Power-Take-Off Shaft Assembly No. SVA10500 .....	11
Sidewall Assembly .....	12
Left Hand Sidewall Assembly .....	13
Right Hand Sidewall Assembly .....	14
Door Assembly .....	15
Link-Lower Door Assembly.....	16
Cylinder Assembly .....	17
Hydraulic Cylinder Assembly No. 107-1360 .....	18
Hydraulic Schematic Assembly .....	19

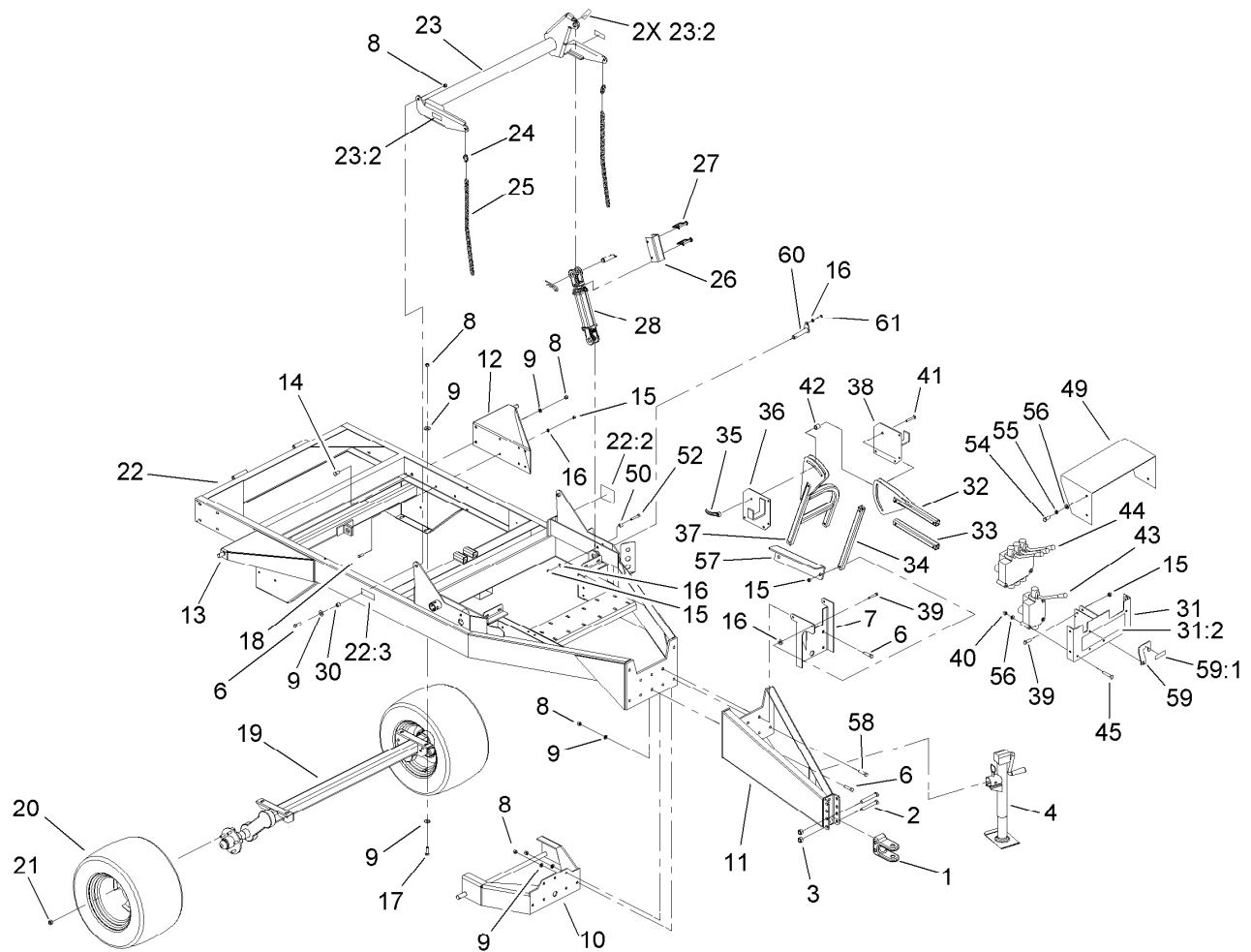

## Frame and Axle Assembly

Ref.	Part Number	Qty.	Description	Ref.	Part Number	Qty.	Description
1	47-3550-03	1	Hitch-Clevis	23:2	93-6674	3	Decal-Warning
2	327-23	2	Screw-HH	24	CSP15000	2	Link-Quick
3	3296-53	2	Nut-Lock, NI	25	SV139-00	2	Chain-Link
4	106-9699	1	Jack	26	SV158-00-03	1	Channel-Lock
6	325-8	5	Screw-HH	27	PF244-00	2	Pin-Wire, Lock
7	SVA17500-03	1	Base-Stand	28	107-1180	1	Cylinder-HYD
8	3296-23	20	Nut-Lock, NI	30	CS130-00	2	Spacer
9	3256-6	24	Washer-Flat	31	106-0186	1	Mount-Valve
10	SVA11200-03	1	Deck Mount ASM	31:2	106-0183	1	Decal-Panel, Control
11	SV198-00-03	1	Hitch	32	SVA17100-03	1	Stand-Valve
12	SVA11300-03	1	Bracket-Door, Left	33	SVA17200-03	1	Tube-Horizontal
13	SVA11400-03	1	Bracket-Door, Right	34	SVA17000-03	1	Tube-Vertical
14	325-5	4	Screw-HH	35	SVA18500	1	Handle-Locking
15	3296-39	18	Nut-Lock, NI	36	SVA17400-03	1	Hanger-Hose, Right
16	3256-24	29	Washer-Flat	37	SVA16900-03	1	Stand-Valve
17	325-6	4	Screw-HH	38	SVA17900-03	1	Hanger-Hose, Left
18	323-6	8	Screw-HH	39	323-11	9	Screw-HH
19	SVP20000	1	Axle-Torflex	40	3296-29	6	Nut-Lock, NI
20	SVP15000	2	Tire And Wheel ASM	41	3231-31	1	Screw-CARR
21	242-50	10	Nut-Lug	42	SVA17700	1	Spacer
22	106-0189	1	Frame	43	106-0168	1	Valve-Control, Single Spool
22:2	106-0167	1	Decal-Caution	43:1	107-1551	1	Seal Kit ●
22:3	106-0162	2	Decal-Caution, Stay Clear (Ce)	44	106-0169	1	Valve-Control, Three Spool
23	106-0190	1	Arm-Lift	44:1	107-1550	1	Seal Kit ●
				45	322-13	6	Screw-HH

● Not illustrated

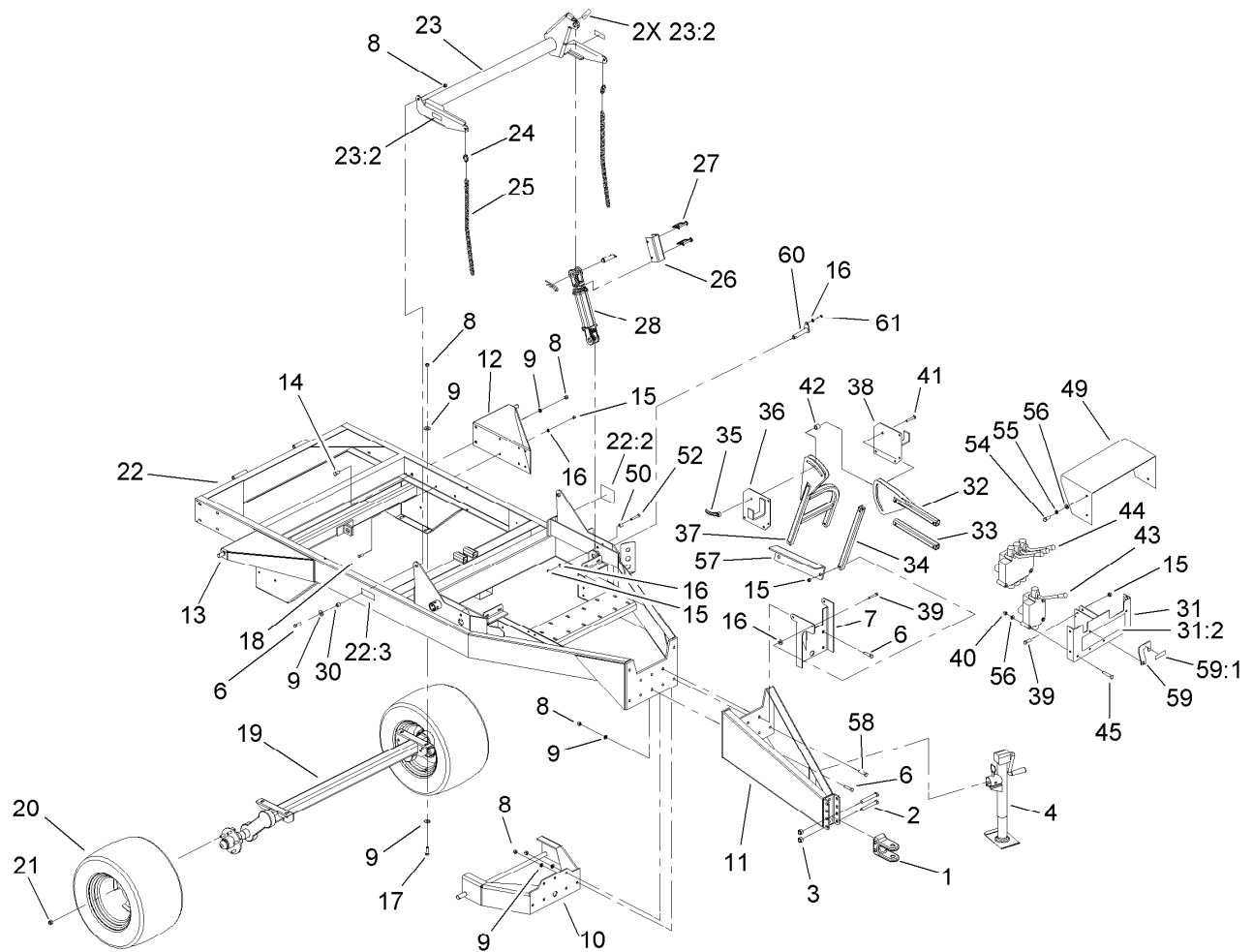

## Frame and Axle Assembly (continued)

<i>Ref.</i>	<i>Part Number</i>	<i>Qty.</i>	<i>Description</i>	<i>Ref.</i>	<i>Part Number</i>	<i>Qty.</i>	<i>Description</i>
49	106-0171-03	1	Guard-Hose	57	105-4855-03	1	Support
50	SV136-00-03	1	Roller-Chain	58	325-10	6	Screw-HH
52	325-12	1	Screw-HH	59	110-7505	1	Lockout-Valve
54	322-2	4	Screw-HH	59:1	110-7506	1	Decal-Caution (Ce)
55	3253-4	4	Washer-Lock	60	107-1186	1	Pin
56	3256-23	10	Washer-Flat	61	323-7	1	Screw-HH

● Not illustrated

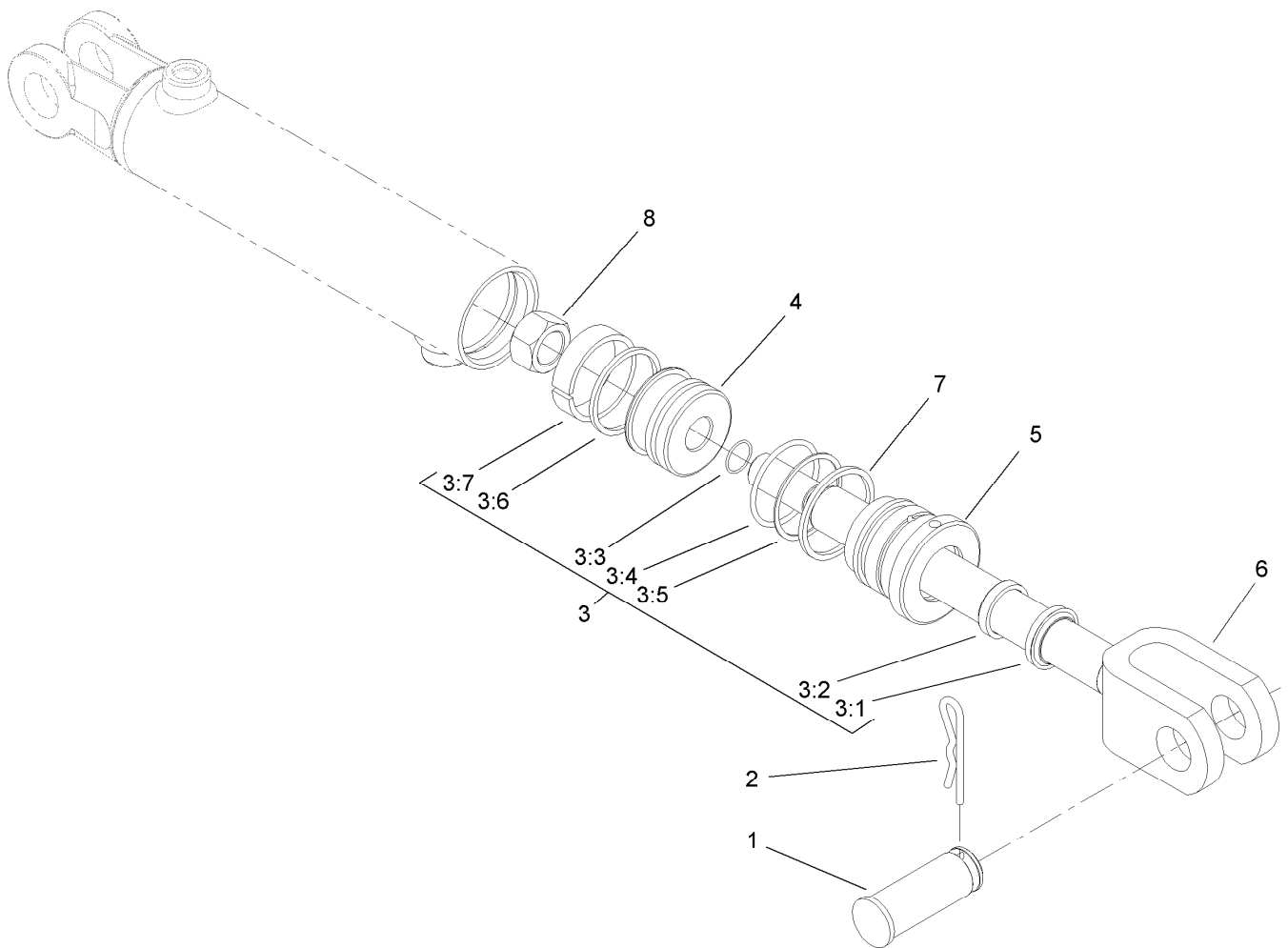

## Hydraulic Cylinder Assembly No. 107-1180

Ref.	Part Number	Qty.	Description
1	107-1182	2	Pin-Clevis
2	9335064	2	Pin-Cotter, Hair
3	107-1183	1	Seal Kit
3:1		1	Wiper ●
3:2		1	U-Cup ●
3:3		1	Seal-Dust ●
3:4		1	Seal-Dust ●
3:5		1	Back-Up Ring ●
3:6		1	Capseal ●
3:7		1	Wear Ring ●
4		1	Piston ●
5		1	Head ●
6		1	Rod ASM ●
7		1	Ring-Retaining ●
8		1	Nut-Lock ●

● Not serviced separately

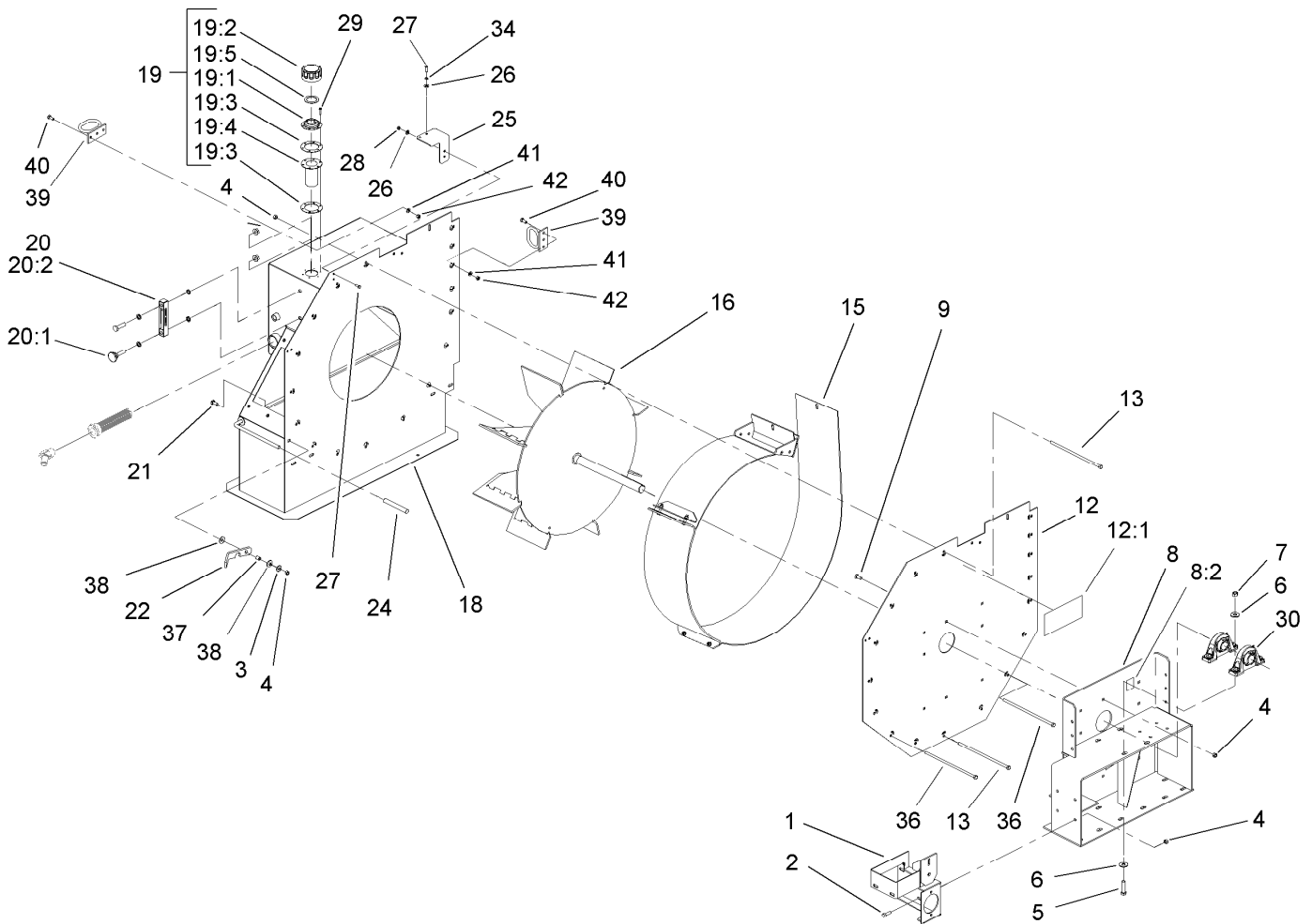

## Impeller Assembly

<i>Ref.</i>	<i>Part Number</i>	<i>Qty.</i>	<i>Description</i>	<i>Ref.</i>	<i>Part Number</i>	<i>Qty.</i>	<i>Description</i>
1	108-0894-01	1	Mount-Pump	19:5	76-1720	1	Gasket-Cap, Filler
2	323-7	4	Screw-HH	20	SVB14700	1	Thermometer ASM
3	3256-4	4	Washer-Flat	20:1	108-0852	1	Probe-Temp
4	104-8301	30	Nut-Flange, NI	20:2	108-0853	1	Body-Temp
5	325-8	4	Screw-HH	21	3231-28	1	Screw-CARR
6	3256-6	8	Washer-Flat	22	106-0236-01	1	Latch
7	3296-23	4	Nut-Lock, NI	24	PF225-00	1	Cover-Handle
8	106-0191	1	Mount-Drive	25	SVB15900-01	1	Mount-Filter
8:2	105-4586	1	Decal-Shield	26	3256-22	6	Washer-Flat
9	3231-2	8	Bolt-CARR	27	321-4	4	Screw-HH
12	106-0206	1	Panel-Back	28	3296-42	2	Nut-Lock, NI
12:1	66-6140	1	Decal	29	32144-18	6	Screw-HWH
13	105-4865	15	Screw-HH	30	106-0332	2	Bearing-Block, Pillow
15	107-1359	1	Band ASM	34	3253-3	2	Washer-Lock
16	107-1431-01	1	Impeller ASM	36	105-4865	2	Screw-HH
18	SV305-00-01	1	Funnel ASM	37	92-9025	1	Spacer
19	95-7004	1	Filler Cap ASM	38	3290-473	2	Washer-Belleville
19:1	353-961	1	Flange	39	104-0028	2	Guide-Hose
19:2	353-962	1	Cap ASM	40	322-5	4	Screw-HH
19:3	353-963	2	Gasket	41	3256-23	4	Washer-Flat
19:4	62-2610	1	Strainer-Cap, Filler	42	3296-29	4	Nut-Lock, NI

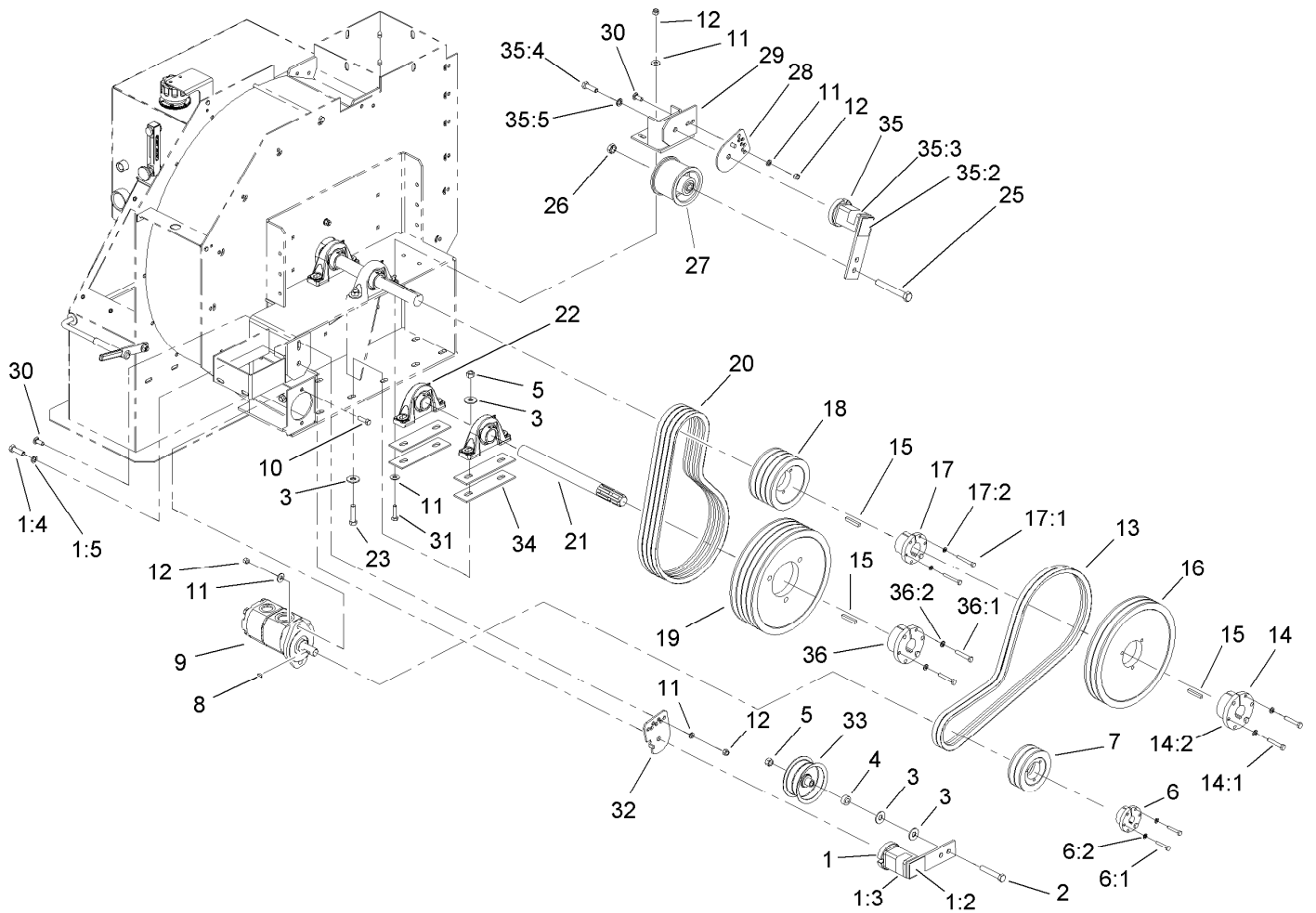

## Drive Assembly

Ref.	Part Number	Qty.	Description	Ref.	Part Number	Qty.	Description
1	105-0667	1	Idler Tensioner ASM	17:2	3253-3	3	Washer-Lock
1:2	105-0668	1	Decal-Align	18	106-0355	1	Pulley
1:3	105-0669	1	Decal-Angle	19	106-0356	1	Pulley
1:4	33116-040	1	Screw-HH	20	SBC17000	4	V-Belt
1:5	3253-7	1	Washer-Lock	21	SVB13000	1	Shaft-Input
2	325-12	1	Screw-HH	22	106-0332	2	Bearing-Block, Pillow
3	3256-6	10	Washer-Flat	23	325-10	4	Screw-HH
4	GF213-00	1	Spacer	25	3214-15	1	Screw-HH
5	3296-23	5	Nut-Lock, NI	26	3220-6	1	Nut-Jam
6	106-0357	1	Bushing-Pulley	27	105-4821	1	Idler-Pulley
6:1	108-0854	3	Screw-HSH	28	105-4839	1	Stabilizer-Tensioner
6:2	3253-3	3	Washer-Lock	29	SV286-00-01	1	Bracket-Lovejoy
7	106-0352	1	Pulley	30	3231-25	2	Bolt-CARR
8	3257-32	1	Key-Woodruff	31	323-8	4	Screw-HH
9	108-0856	1	Pump-HYD	32	105-4835	1	Stabilizer-Tensioner
10	323-7	6	Screw-HH	33	FBJ11100	1	Pulley-Idler
11	3256-4	12	Washer-Flat	34	SVB19500-01	4	Shim
12	3296-39	8	Nut-Lock, NI	35	106-0334	1	Idler Tensioner ASM
13	SVB13600	2	V-Belt	35:2	105-0668	1	Decal-Align
14	106-0358	1	Pulley Bushing ASM	35:3	105-0669	1	Decal-Angle
14:1	322-10	3	Screw-HH	35:4	33116-040	1	Screw-HH
14:2	3253-4	3	Washer-Lock	35:5	3253-7	1	Washer-Lock
15	61-004-0451	3	Key-Square	36	106-0362	1	Bushing-Pulley
16	106-0353	1	Pulley	36:1	325-11	3	Screw-HH
17	106-0360	1	Pulley Bushing ASM	36:2	3253-7	3	Washer-Lock
17:1	321-11	3	Screw-HH				



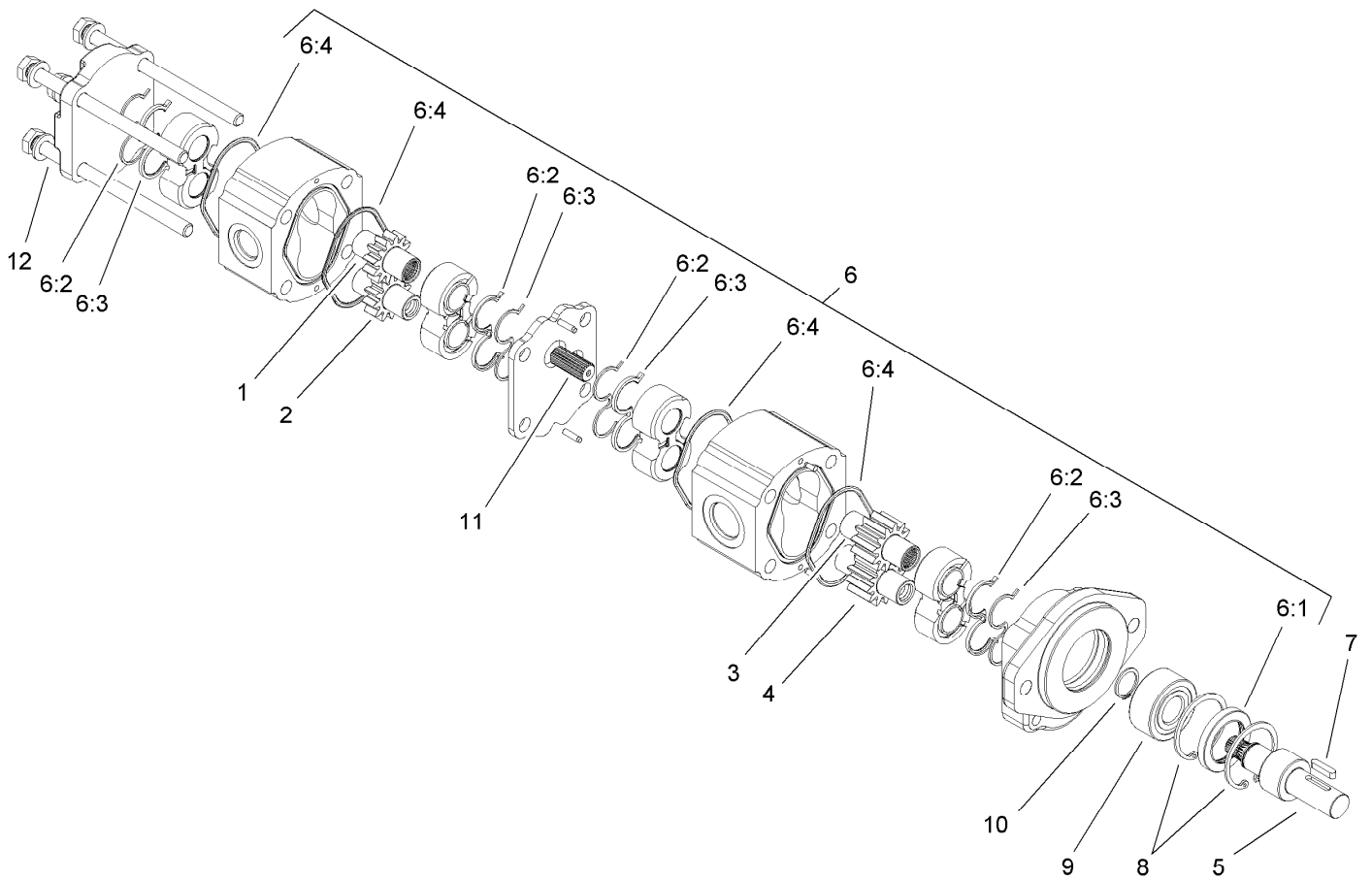

## Hydraulic Double Gear Pump Assembly No. 108-0856

Ref.	Part Number	Qty.	Description
1		1	Gear-Drive ●
2		1	Gear-Driven ●
3		1	Gear-Drive ●
4		1	Gear-Driven ●
5		1	Shaft ●
6	108-2438	1	Seal Kit
6:1		1	Seal-Lip ●
6:2		4	Seal-Back Up ●
6:3		4	Seal-Channel ●
6:4		4	Seal-Section ●
7		1	Key ●
8		1	Bearing ●
9		1	Ring-Retaining ●
10		1	Ring-Retaining ●
11		1	Shaft ●
12		1	Washer ●

● Not serviced separately

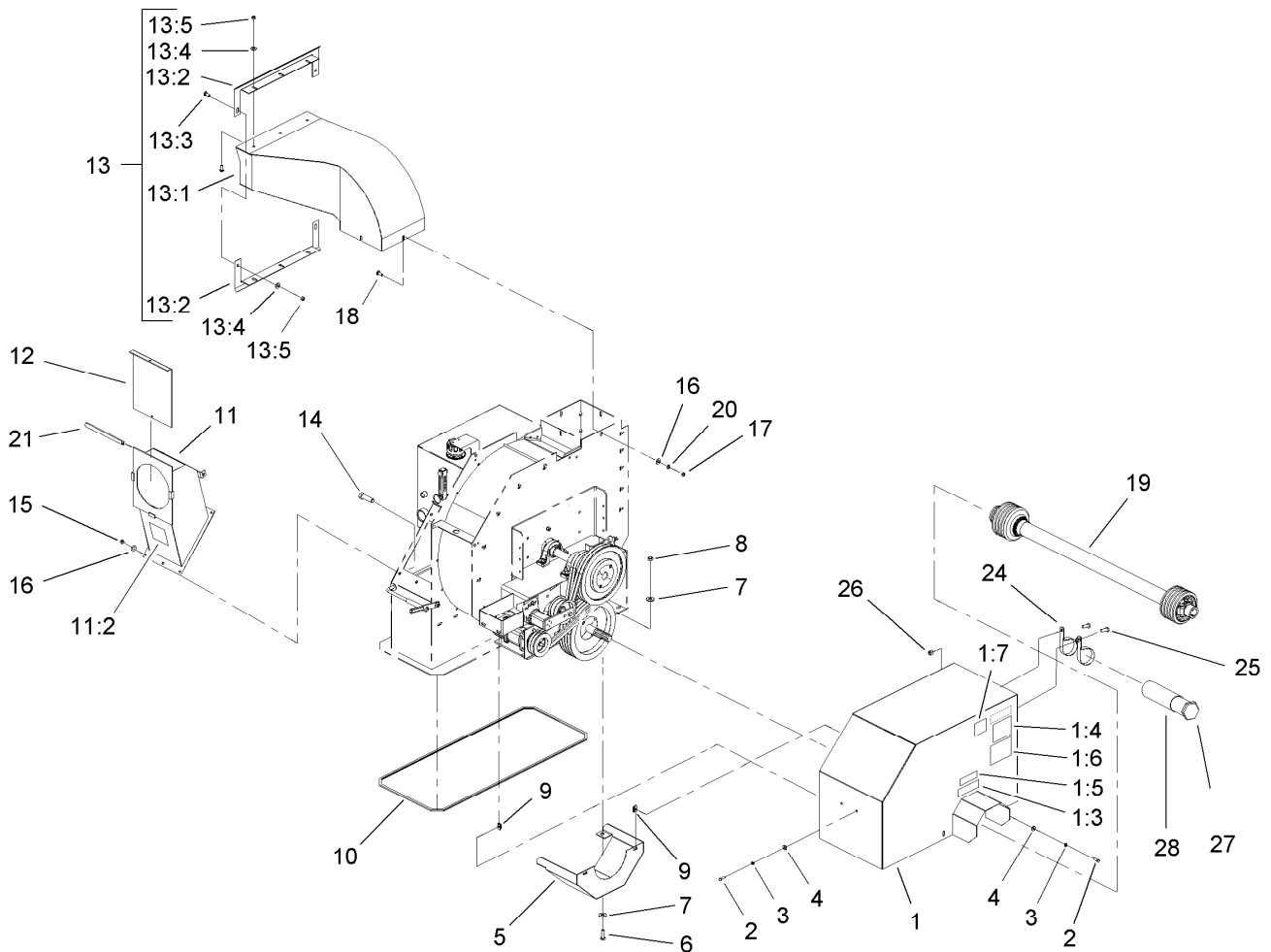

## Power-Take-Off Shaft and Shield Assembly

Ref.	Part Number	Qty.	Description	Ref.	Part Number	Qty.	Description
1	106-0193	1	Shield-Drive	13:1	SV216-00-01	1	Transition-Spout
1:3	105-0628	1	Decal-Caution, U-Joint	13:2	SVA10200-01	2	Seal-Dust
1:4	105-4587	1	Decal-Caution, Ce	13:3	3231-2	8	Bolt-CARR
1:5	105-0627	1	Decal-Caution	13:4	3256-24	8	Washer-Flat
1:6	106-0163	1	Decal-Danger, Blowers	13:5	3296-39	8	Nut-Lock, NI
1:7	105-4586	1	Decal-Shield	14	3231-2	6	Bolt-CARR
2	322-5	6	Screw-HH	15	3296-39	6	Nut-Lock, NI
3	3253-4	6	Washer-Lock	16	3256-4	10	Washer-Flat
4	3256-23	6	Washer-Flat	17	3217-7	4	Nut-Hex
5	105-4842-01	1	Guard-Pulley	18	3231-2	4	Bolt-CARR
6	325-6	2	Screw-HH	19	SVA10500	1	Shaft-PTO, Double
7	3256-6	4	Washer-Flat	20	3253-21	4	Washer-Lock
8	3296-23	2	Nut-Lock, NI	21	106-0207	1	Trim-Chute Vac
9	CSP11700	4	Nut-Thin, Tinnerman	24	2412-133	2	R-Clamp
10	105-4843	1	Trim	25	323-5	2	Screw-HH
11	106-0192	1	Chute-Vac	26	3296-39	2	Nut-Lock, NI
11:2	106-0166	1	Decal-Danger, Blower	27	104-7048	1	Cap-Housing
12	SV143-00-01	1	Door-Hose	28	104-7050	1	Tube-Manual
13	SVA14900	1	Spout ASM				

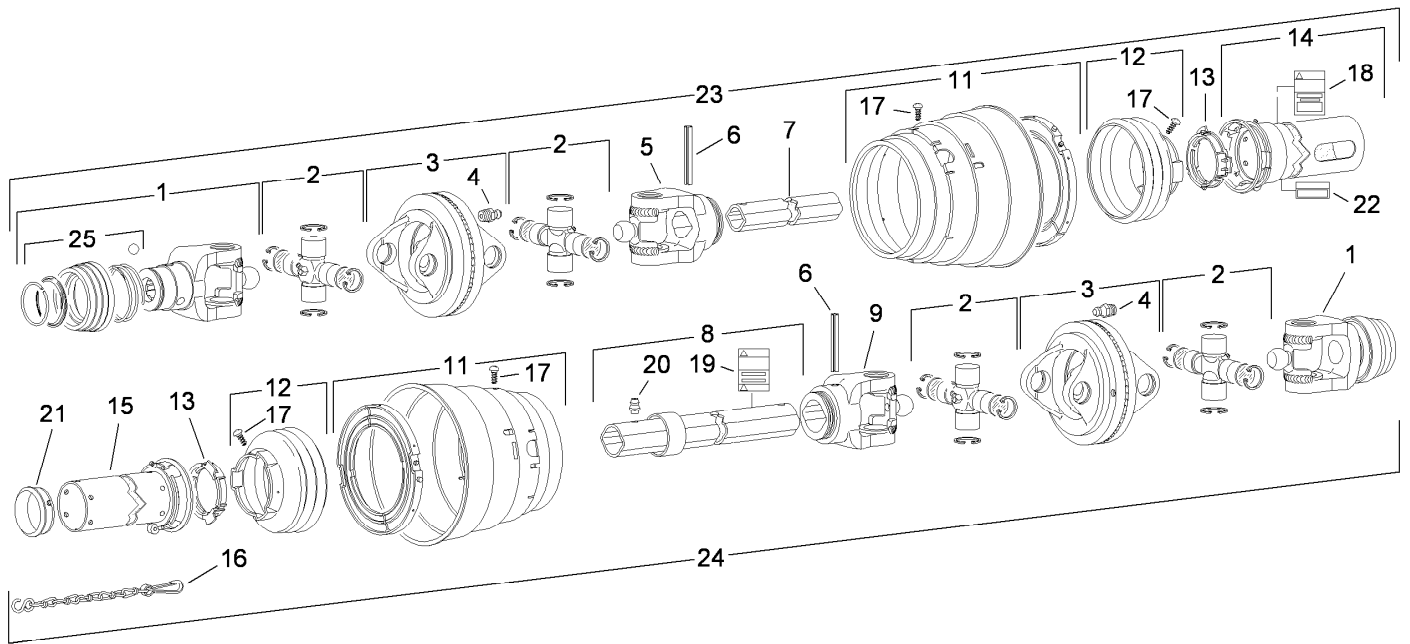

## Double Power-Take-Off Shaft Assembly No. SVA10500

Ref.	Part Number	Qty.	Description
1	120-6119	1	Yoke ASM
2	SVA10501	4	Cross And Bearing Kit
3	120-6120	2	Double Yoke
4	84-6290	2	Zerk-Grease
5	SVA10508	1	Yoke-Inboard, Tractor End
6	105-2927	2	Pin-Spring
7	120-6121	1	Tube-Inner
8	SVA10511	1	Tube-Outer
9	SVA10509	1	Yoke-Inboard, Implement End
11	120-6122	1	Guard And Bearing ASM
12	120-6123	1	Guard Cone,3 Rib
13	105-2936	2	Bearing-Ring
14	SVA10502	1	Shield-Outer
15	SVA10503	1	Shield-Inner
16	77-4760	1	Chain-Safety
17	84-6360	14	Screw
18	92-7936	1	Decal-Warning
19	92-7937	1	Decal-Warning
20	84-6370	1	Zerk-Grease
21		1	Support-Bearing ●
22		1	Decal-Lubrication ●
23	SVA1050T	1	Shaft-Double Cv, PTO (Tractor Half)
24	SVA1050I	1	Shaft-Double Cv, PTO (Implement Half)
25	120-6124	1	Collar Kit ASM

● Not serviced separately

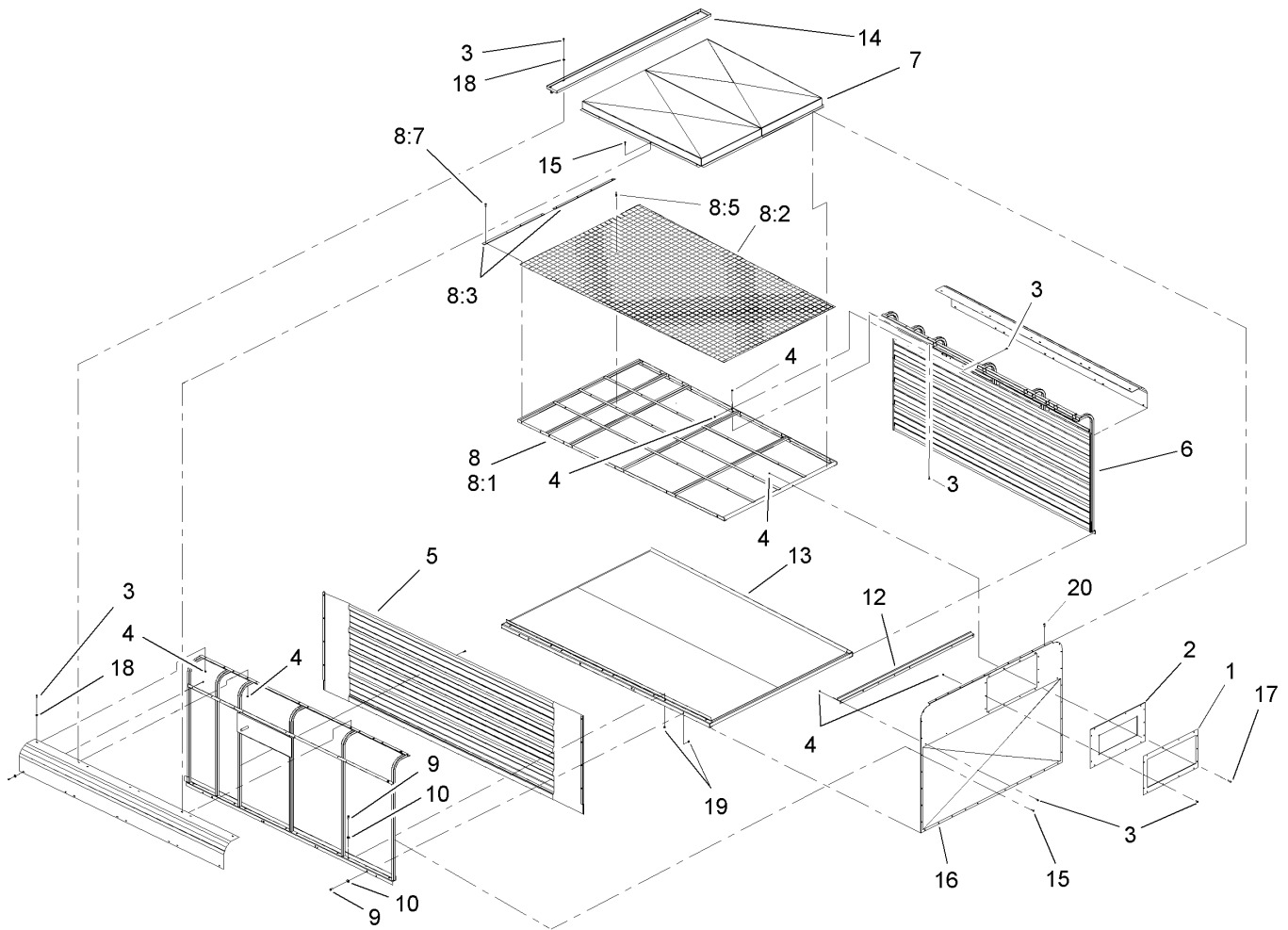

## Sidewall Assembly

Ref.	Part Number	Qty.	Description
1	107-1362-01	1	Plate
2	107-1361	1	Gasket-Dust
3	321-4	69	Screw-HH
4	3296-42	73	Nut-Lock, NI
5		1	LH Sidewall ASM ●
6		1	RH Sidewall ASM ●
7	107-1495-01	1	Cap-Dust
8		1	Roof-Trailer ●
8:1	VT306-00-01	1	Roof Frame ASM
8:2	VT307-00	2	Screen-Roof
8:3	VT308-00-01	2	Trim-Edge
8:5	3269-21	15	Rivet-Pop
8:7	105-0618	8	Screw
9	323-6	24	Screw-HH
10	3256-24	24	Washer-Flat
12	SVA12000-01	1	Brace-Front
13	VT301-00-03	1	Frame-Floor
14	SVA11900-01	1	Hinge Mount ASM
15	105-0618	28	Screw
16	107-1363-01	1	Sheet-Trailer, Front
17	321-10	4	Screw-HH
18	3256-22	56	Washer-Flat
19	3290-357	24	Nut-HHF, Whiz
20	105-4848	14	Screw

● Not serviced separately

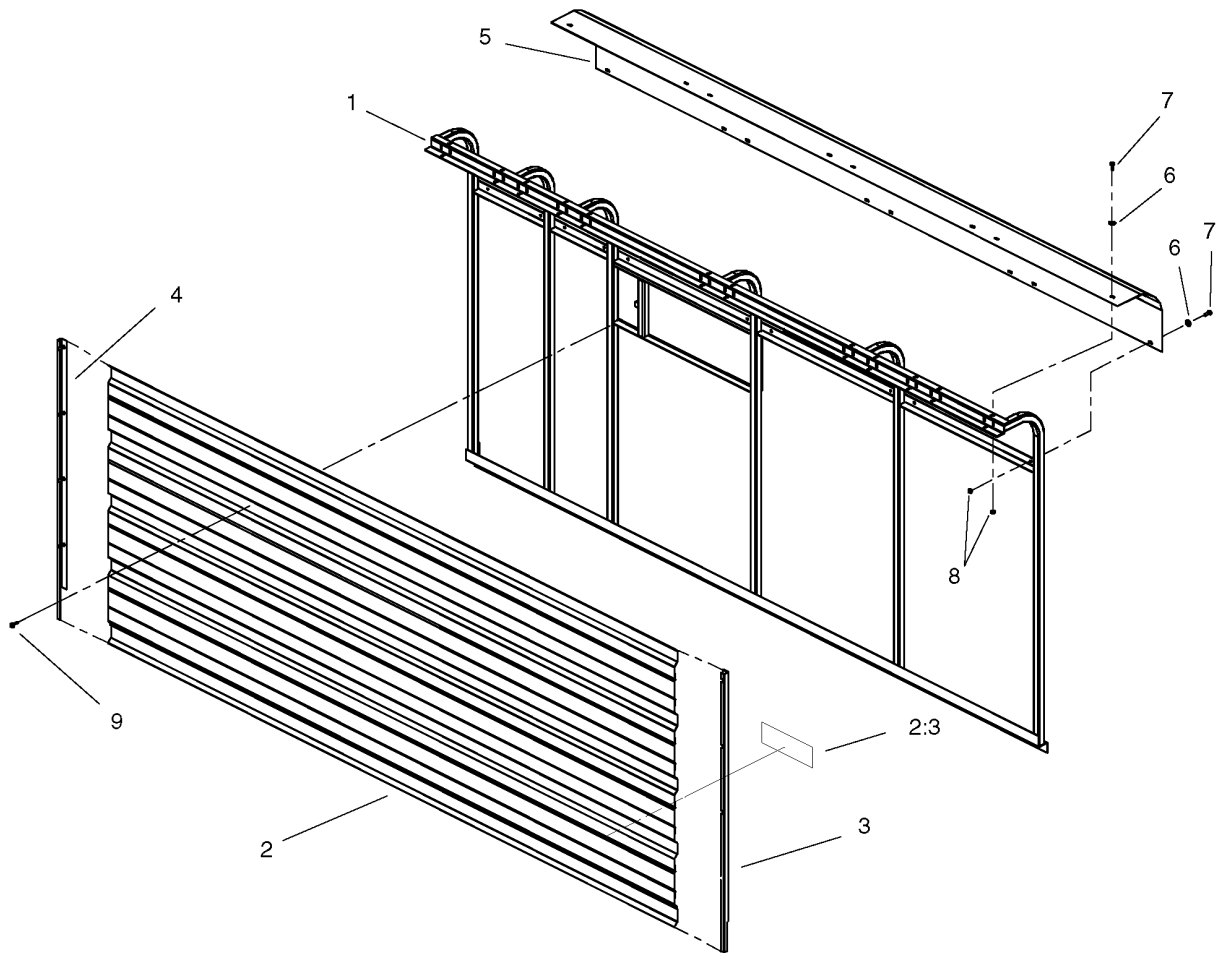

## Left Hand Sidewall Assembly

<i>Ref.</i>	<i>Part Number</i>	<i>Qty.</i>	<i>Description</i>
1	VT203-0L-01	1	Left Wall ASM
2	106-0176	1	Sheet-Sidewall, LH
2:3	106-0162	1	Decal-Caution, Stay Clear (Ce)
3	VT130-0L-01	1	Trim-Enclosure, Left
4	106-0175	1	Corner-Roof, LH
5	VT130-0R-01	1	Trim-Enclosure, Right
6	3256-22	8	Washer-Flat
7	321-4	8	Screw-HH
8	3296-42	8	Nut-Lock, NI
9	105-0618	24	Screw

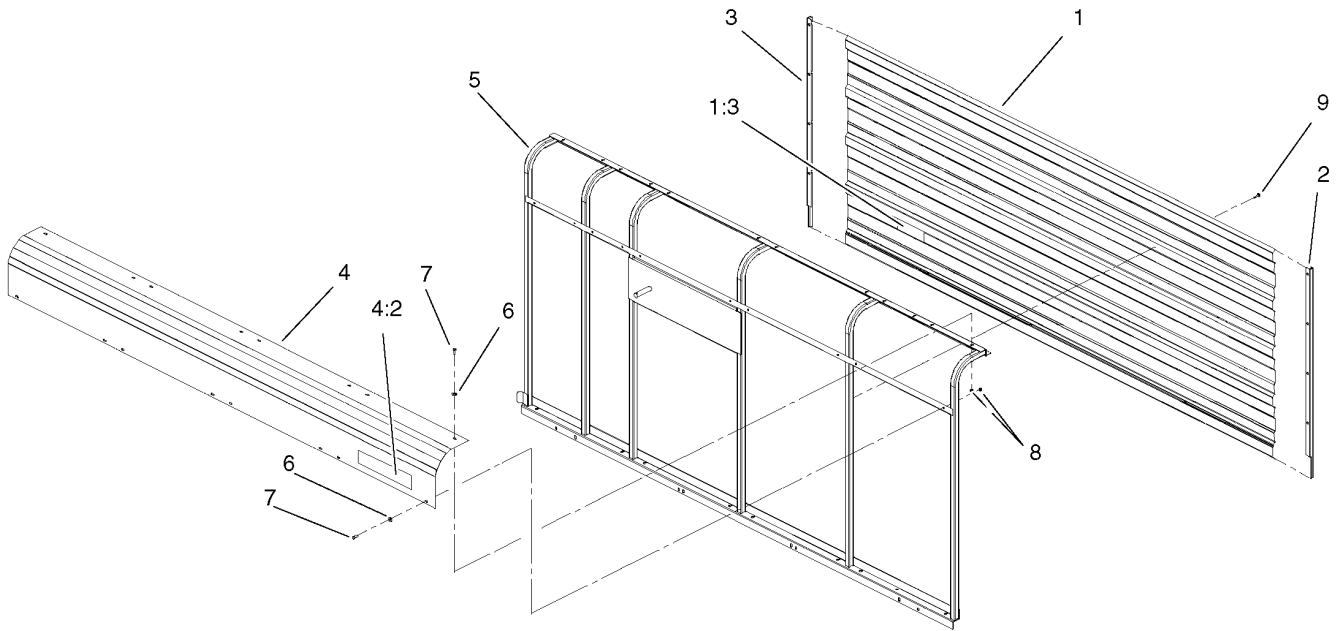

## Right Hand Sidewall Assembly

<i>Ref.</i>	<i>Part Number</i>	<i>Qty.</i>	<i>Description</i>
1	106-0174	1	Sheet-Sidewall, RH
1:3	106-0162	1	Decal-Caution, Stay Clear (Ce)
2	VT130-0R-01	1	Trim-Enclosure, Right
3	VT130-0L-01	1	Trim-Enclosure, Left
4	106-0173	1	Corner-Roof, RH
4:2	105-0738	1	Decal-RH
5	VT203-0R-01	1	Right Wall ASM
6	3256-22	8	Washer-Flat
7	321-4	8	Screw-HH
8	3296-42	8	Nut-Lock, NI
9	105-0618	24	Screw

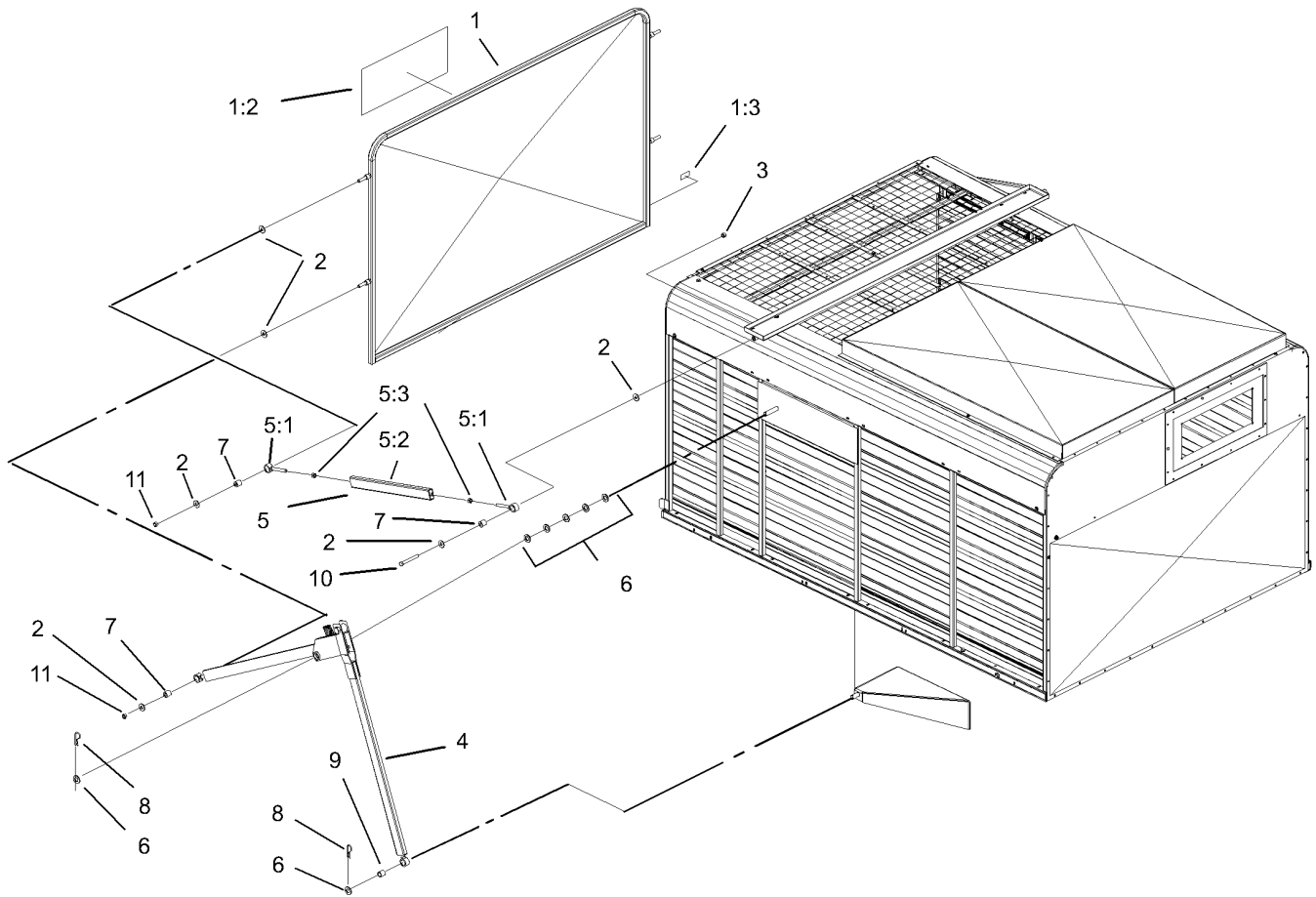

## Door Assembly

<i>Ref.</i>	<i>Part Number</i>	<i>Qty.</i>	<i>Description</i>
1	106-0194	1	Door-Trailer
1:2	67-7920	1	Decal
1:3	106-0162	1	Decal-Caution, Stay Clear (Ce)
2	3256-5	12	Washer-Flat
3	3296-23	2	Nut-Lock, NI
4	SVA15100	2	Lower Link Door ASM
5	SVA15000	2	Upper Link Door ASM
5:1	SVA11700-01	1	Link ASM
5:2	SVA12200	2	Pivot-Hinge
5:3	3217-9	2	Nut-HH
6	3256-28	14	Washer-Flat
7	SVA12700	6	Bushing
8	9335064	4	Pin-Cotter, Hair
9	SVA12800	2	Bushing
10	325-17	2	Screw-HH
11	32153-5	4	Nut-Hex

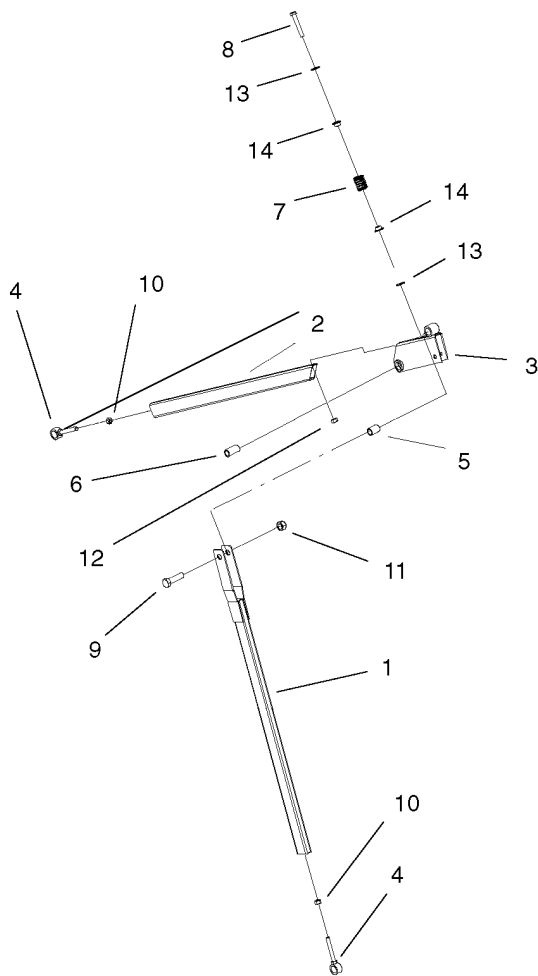

## Link-Lower Door Assembly

<b>Ref.</b>	<b>Part Number</b>	<b>Qty.</b>	<b>Description</b>
1	SVA11800-01	1	Pull Arm ASM
2	SVA11600-01	1	Lower Linkage ASM
3	SVA12100-01	1	Mount-Bracket
4	SVA12200	2	Pivot-Hinge
5	SVA12900	1	Bushing
6	SVA13000	1	Bushing
7	GF206-00	1	Spring-Compression
8	325-13	1	Screw-HH
9	328-3	1	Screw-HH
10	3217-9	2	Nut-HH
11	3296-51	1	Nut-Lock, NI
12	3296-23	1	Nut-Lock, NI
13	3256-26	2	Washer-Flat
14	SVA13300	2	Bushing-Flange



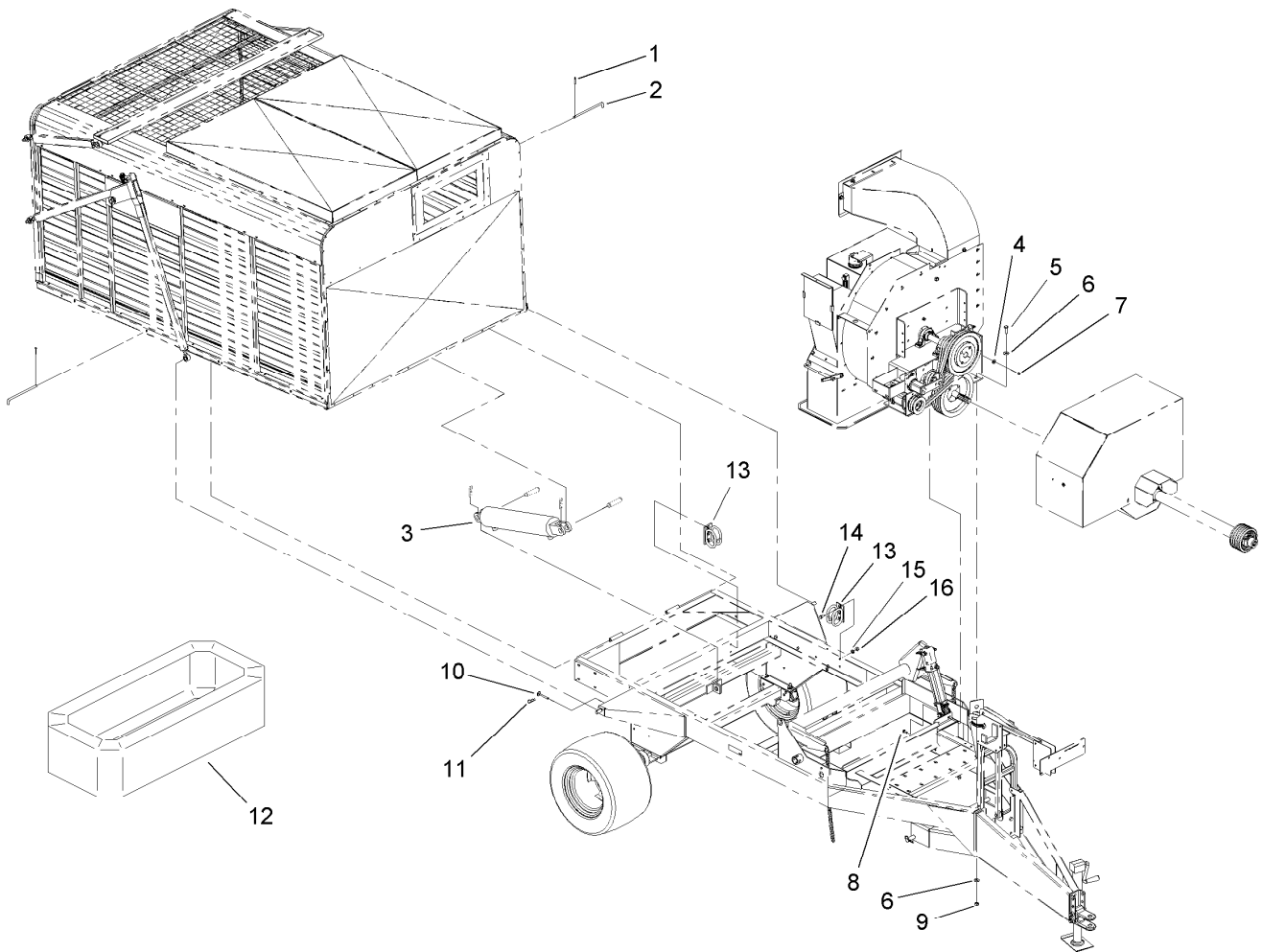

## Cylinder Assembly

<i>Ref.</i>	<i>Part Number</i>	<i>Qty.</i>	<i>Description</i>
1	3272-22	2	Pin-Cotter
2	PB114-00	2	Pin-Hinge
3	107-1360	1	HYD Cylinder ASM
4	3256-4	4	Washer-Flat
5	325-6	5	Screw-HH
6	3256-6	10	Washer-Flat
7	3296-39	4	Nut-Lock, NI
8	3231-25	4	Bolt-CARR
9	3296-23	5	Nut-Lock, NI
10	SVA12600	2	Door Pin ASM
11	3290-355	2	Pin-Hair
12	SVP15100	1	Ring-Canvas
13	99-5621	2	Guide-Hose
14	322-5	4	Screw-HH
15	3256-23	4	Washer-Flat
16	3296-29	4	Nut-Lock, NI

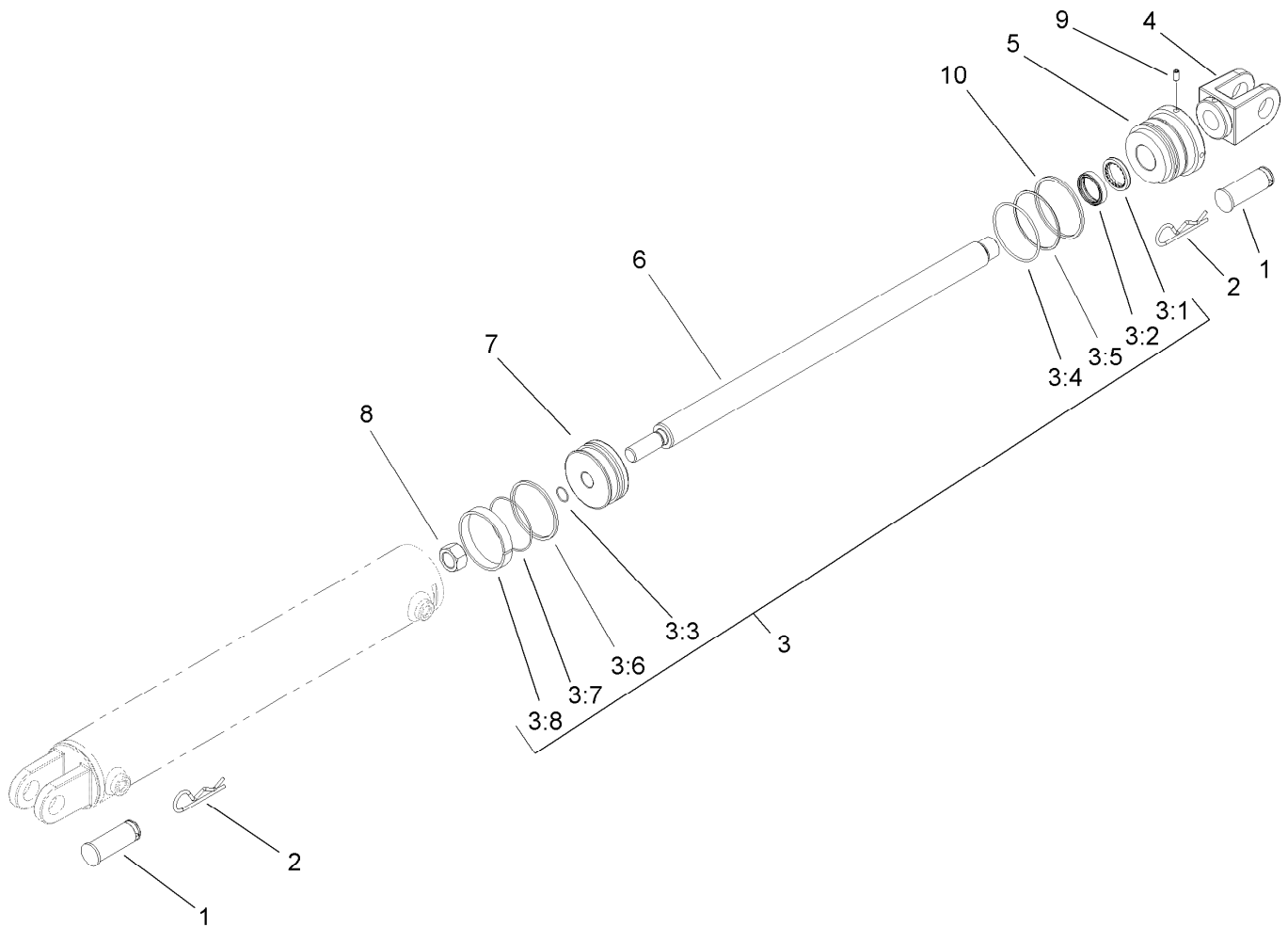

## Hydraulic Cylinder Assembly No. 107-1360

Ref.	Part Number	Qty.	Description
1	107-1182	2	Pin-Clevis
2	9335064	2	Pin-Cotter, Hair
3	108-2435	1	Seal Kit
3:1		1	Wiper ●
3:2		1	Seal ASM ●
3:3		1	Seal-Dust ●
3:4		1	Seal-Dust ●
3:5		1	Ring-Back Up ●
3:6		1	Seal ASM ●
3:7		1	Seal-Dust ●
3:8		1	Ring-Wear ●
4	108-2436	1	Clevis-Rod
5		1	Head ●
6		1	Rod ●
7		1	Piston ●
8		1	Nut-Lock ●
9		1	Screw-Set ●
10		1	Ring-Retaining ●

● Not serviced separately

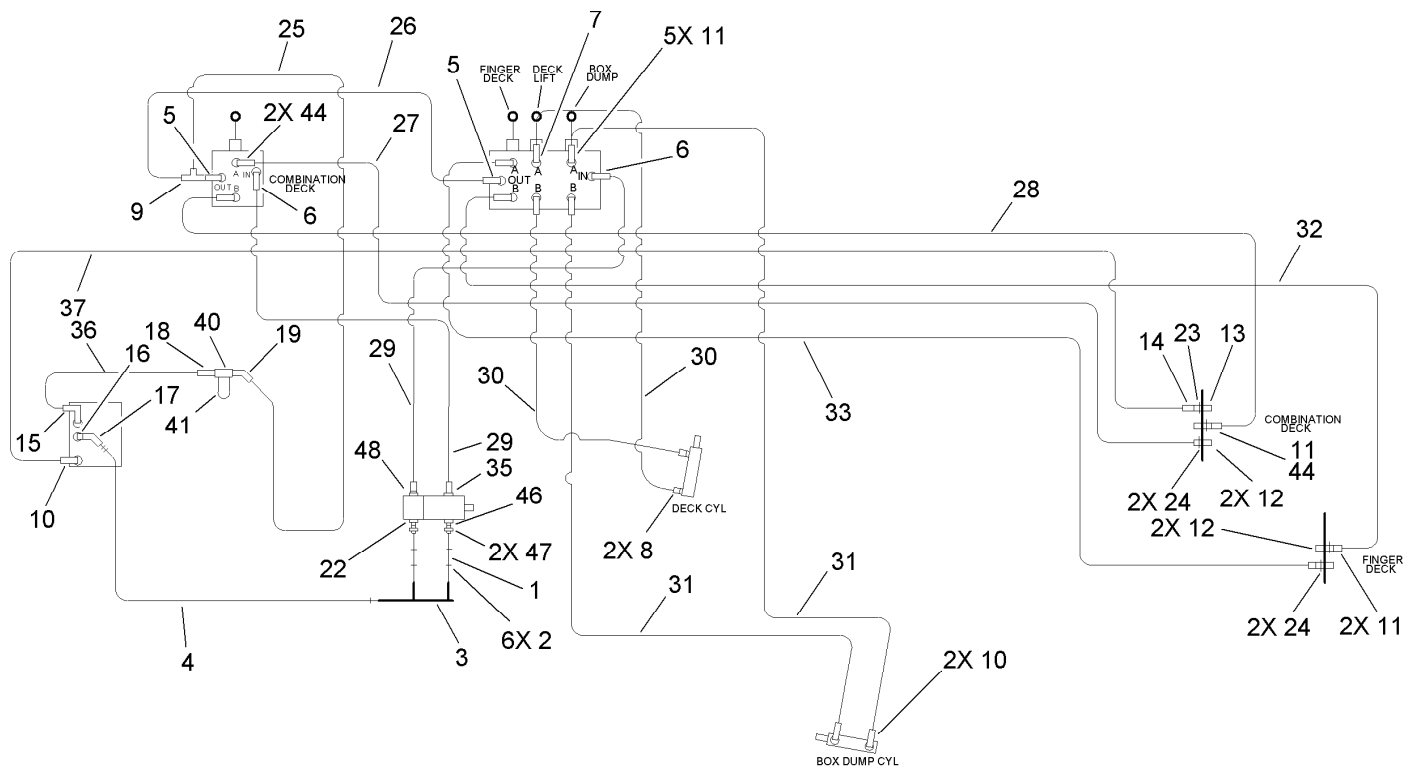

## Hydraulic Schematic Assembly

Ref.	Part Number	Qty.	Description	Ref.	Part Number	Qty.	Description
1	106-0072	2	Hose-Suction	13	63-1220	1	Coupler-Disconnect, Quick
2	2412-129	6	Clamp-Hose	14	340-82	1	Adapter
3	108-0855	1	Tube-Maniflod	14:1	237-42	1	O-Ring ●
4	106-0071	1	Hose-Suction	14:2	237-21	1	O-Ring ●
5	340-7	2	Adapter	15	340-108	1	Fitting-HYD
5:1	237-65	1	O-Ring ●	16	SVB14400	1	Strainer-Suction
5:2	237-80	1	O-Ring ●	17	SVB15100	1	Adapter-Cms
6	340-6	2	Fitting-HYD, Straight	18	340-8	1	Adapter
6:1	237-30	1	O-Ring ●	18:1	237-65	1	O-Ring ●
6:2	237-80	1	O-Ring ●	18:2	237-81	1	O-Ring ●
7	106-0073	1	Fitting-Orificed	19	340-156	1	Fitting-HYD
7:1	237-22	1	O-Ring ●	19:1	237-65	1	O-Ring ●
7:2	237-79	1	O-Ring ●	19:2	237-81	1	O-Ring ●
7:99	32151-83	1	Ring-Snap ●	22	340-9	1	Fitting-HYD, Straight
8	340-2	2	Fitting-HYD, Straight	22:1	237-58	1	O-Ring ●
8:1	237-22	1	O-Ring ●	22:2	237-81	1	O-Ring ●
8:2	237-42	1	O-Ring ●	23	32151-83	1	Ring-Snap
9	340-147	1	Fitting-HYD, Tee	24	32120-2	4	Ring-Retaining
9:1	237-65	2	O-Ring ●	25	105-0649	1	Hyd Hose ASM
10	340-124	3	Adapter	26	105-0648	1	Hyd Hose ASM
10:1	237-22	1	O-Ring ●	27	105-0650	1	Hyd Hose ASM
11	340-3	7	Adapter	27:3	237-79	1	O-Ring ●
11:1	237-22	1	O-Ring ●	28	105-0651	1	Hyd Hose ASM
11:2	237-79	1	O-Ring ●	29	105-0653	2	Hyd Hose ASM
12	105-4169	4	Coupler-Female	30	105-0642	2	Hyd Hose ASM

● Not illustrated

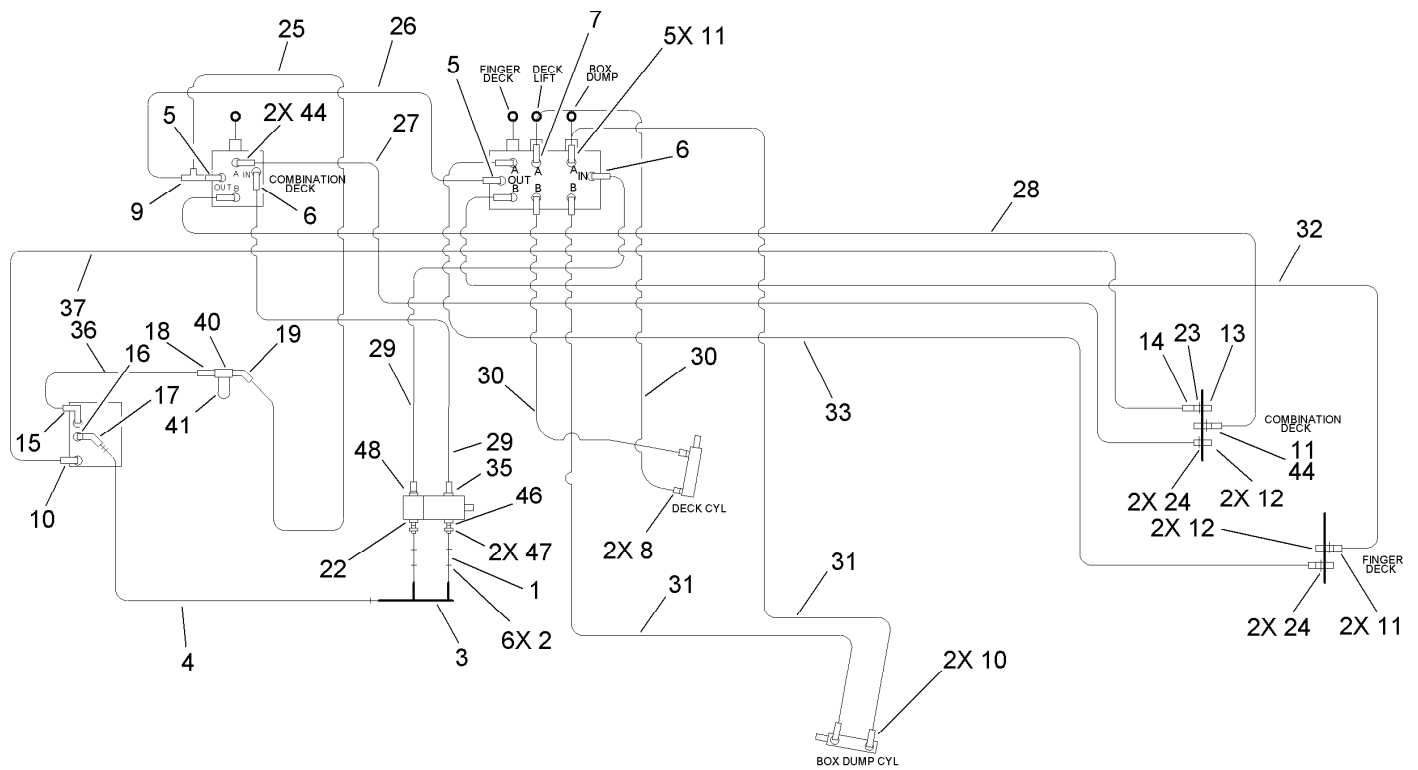

## Hydraulic Schematic Assembly (continued)

Ref.	Part Number	Qty.	Description	Ref.	Part Number	Qty.	Description
31	105-0652	2	Hyd Hose ASM	44	340-4	3	Fitting-HYD, Straight
32	105-0645	1	Hyd Hose ASM	44:1	237-30	1	O-Ring ●
33	105-0646	1	Hyd Hose ASM	44:2	237-79	1	O-Ring ●
35	340-131	1	Fitting-HYD, 90 DEG	46	340-91	1	Adapter
35:1	237-30	1	O-Ring ●	46:1	237-58	1	O-Ring
35:2	237-81	1	O-Ring ●	46:2	237-146	1	O-Ring
36	105-0638	1	Hyd Hose ASM	47	108-0884	2	Fitting-Elbow, 90 DEG
37	105-0654	1	Hyd Hose ASM	48	340-105	1	Fitting-HYD, 90 DEG
40	92-5821	1	Head-Filter	48:1	237-80	1	O-Ring ●
41	54-0110	1	Filter-Oil, Transmission	48:2	237-30	1	O-Ring ●
42	SVA13800	10	Tiewire ●				

● Not illustrated

**Notes:**

**Notes:**

**Notes:**



**Count on it.**