



**Count on it.**

**Operator's Manual**

**Z Master<sup>®</sup> Professional 7000  
Series Riding Mower**

**With 132cm or 152cm TURBO FORCE<sup>®</sup> Side  
Discharge Mower**

**Model No. 74264TE—Serial No. 313000001 and Up**

**Model No. 74265TE—Serial No. 313000001 and Up**

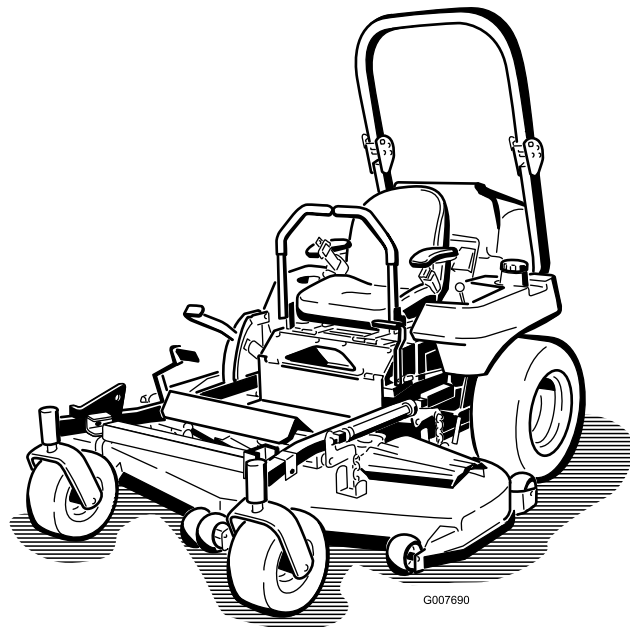

This product complies with all relevant European directives, for details please see the separate product specific Declaration of Conformity (DOC) sheet.

This manual identifies potential hazards and has safety messages identified by the safety alert symbol (Figure 2), which signals a hazard that may cause serious injury or death if you do not follow the recommended precautions.

# Introduction

This rotary-blade, riding lawn mower is intended to be used by residential homeowners or professional, hired operators. It is designed primarily for cutting grass on well-maintained lawns on residential or commercial properties. It is not designed for cutting brush or for agricultural uses.

Read this information carefully to learn how to operate and maintain your product properly and to avoid injury and product damage. You are responsible for operating the product properly and safely.

You may contact Toro directly at [www.Toro.com](http://www.Toro.com) for product and accessory information, help finding a dealer, or to register your product.

Whenever you need service, genuine Toro parts, or additional information, contact an Authorized Service Dealer or Toro Customer Service and have the model and serial numbers of your product ready. Figure 1 identifies the location of the model and serial numbers on the product. Write the numbers in the space provided.

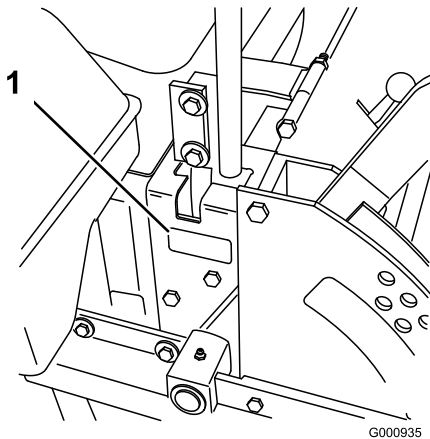

Figure 1

1. Model and serial number location

Model No. _____
Serial No. _____



Figure 2

1. Safety alert symbol

---

This manual uses 2 words to highlight information.

**Important** calls attention to special mechanical information and **Note** emphasizes general information worthy of special attention.

# Contents

Introduction .....	2	Adjusting the Tracking .....	42
Safety .....	4	Checking the Tire Pressure .....	43
Safe Operating Practices .....	4	Checking the Wheel Hub Slotted Nut .....	43
Toro Riding Mower Safety .....	5	Adjusting the Caster Pivot Bearing .....	43
Sound Pressure .....	6	Servicing the Gear Box .....	44
Sound Power .....	6	Adjusting the Electric Clutch .....	44
Vibration Level .....	6	Cooling System Maintenance .....	46
Slope Indicator .....	7	Servicing the Cooling System .....	46
Safety and Instructional Decals .....	8	Brake Maintenance .....	47
Product Overview .....	15	Adjusting the Parking Brake .....	47
Controls .....	15	Belt Maintenance .....	48
Operation .....	16	Inspecting the Belts .....	48
Adding Fuel .....	16	Replacing the Mower Belt .....	48
Biodiesel Ready .....	17	Replacing the PTO Drive Belt .....	49
Filling the Fuel Tank .....	17	Replacing the Pump Drive Belt .....	50
Checking the Engine Oil Level .....	17	Replacing and Tensioning the Alternator Belt .....	50
Switching the Fuel Tanks .....	17	Controls System Maintenance .....	51
Using the Rollover Protection System (ROPS) .....	18	Adjusting the Control Handle Neutral Position .....	51
Think Safety First .....	19	Hydraulic System Maintenance .....	52
Operating the Parking Brake .....	20	Servicing the Hydraulic System .....	52
Starting and Stopping the Engine .....	20	Setting the Hydraulic Pump Neutral Position .....	54
Operating the Power Take Off (PTO) .....	22	Mower Deck Maintenance .....	56
The Safety Interlock System .....	22	Leveling the Mower at Three Positions .....	56
Driving Forward or Backward .....	23	Servicing the Cutting Blades .....	57
Stopping the Machine .....	23	Replacing the Grass Deflector .....	59
Adjusting the Height-of-Cut .....	24	Cleaning .....	60
Adjusting the Anti-Scalp Rollers .....	24	Cleaning Under the Mower .....	60
Adjusting the Flow Baffle .....	25	Waste Disposal .....	60
Positioning the Flow Baffle .....	25	Storage .....	61
Using the Lift Assist Lever .....	26	Cleaning and Storage .....	61
Positioning the Seat .....	26	Troubleshooting .....	62
Changing the Seat Suspension .....	26	Schematics .....	64
Unlatching the Seat .....	27		
Pushing the Machine by Hand .....	27		
Using the Side Discharge .....	27		
Operating with the Overheat Sensor .....	28		
Transporting Machines .....	28		
Loading Machines .....	28		
Using the Z Stand® .....	29		
Operating Tips .....	30		
Maintenance .....	31		
Recommended Maintenance Schedule(s) .....	31		
Lubrication .....	32		
Greasing and Lubrication .....	32		
Greasing the Mower Deck and Belt Idlers .....	33		
Lubricate the Caster Wheel Hubs .....	33		
Engine Maintenance .....	34		
Servicing the Air Cleaner .....	34		
Servicing the Engine Oil .....	35		
Fuel System Maintenance .....	38		
Servicing the Fuel Filter .....	38		
Servicing the Fuel Tank .....	39		
Electrical System Maintenance .....	40		
Servicing the Battery .....	40		
Servicing the Fuses .....	42		
Drive System Maintenance .....	42		

# Safety

This machine meets or exceeds European Standards in effect at the time of production. However, improper use or maintenance by the operator or owner can result in injury. To reduce the potential for injury, comply with these safety instructions and always pay attention to the safety alert symbol, which means CAUTION, WARNING, or DANGER-"personal safety instruction." Failure to comply with the instruction may result in personal injury or death.

## Safe Operating Practices

The following instructions are from the CEN standard EN 836:1997.

This product is capable of amputating hands and feet and throwing objects. Always follow all safety instructions to avoid serious injury or death.

## Training

- Read the instructions carefully. Be familiar with the controls and the proper use of the equipment.
- Never allow children or people unfamiliar with these instructions to use the machine. Local regulations can restrict the age of the operator.
- Never operate the machine while people, especially children, or pets are nearby.
- The operator or user is responsible for accidents or hazards occurring to other people or their property.
- Do not carry passengers.
- All drivers should seek and obtain professional and practical instruction. Such instruction should emphasize:
  - the need for care and concentration when working with ride-on machines;
  - control of a ride-on machine sliding on a slope will not be regained by the application of the control levers. The main reasons for loss of control are:
    - ◇ insufficient wheel grip, especially on wet grass;
    - ◇ being driven too fast;
    - ◇ inadequate braking;
    - ◇ the type of machine is unsuitable for its task;
    - ◇ lack of awareness of the effect of ground conditions, especially slopes;
    - ◇ incorrect hitching and load distribution.

## Preparation

- While operating the machine, always wear substantial footwear and long trousers. Do not operate the machine when barefoot or wearing open sandals.
- Thoroughly inspect the area where the machine is to be used and remove all objects which may be thrown by the machine.
- **Warning**—Fuel is highly flammable.

- Store the fuel in containers specifically designed for this purpose.
- Refuel outdoors only and do not smoke while refuelling.
- Add fuel before starting the engine. Never remove the cap of the fuel tank or add fuel while the engine is running or when the engine is hot.
- If fuel is spilled, do not attempt to start the engine but move the machine away from the area of spillage and avoid creating any source of ignition until fuel vapors have dissipated.
- Replace all fuel tanks and container caps securely.
- Replace faulty silencers.
- Before using, always visually inspect to see that the blades, blade bolts, and cutter assembly are not worn or damaged. Replace worn or damaged blades and bolts in sets to preserve balance.
- On multi-bladed machines, take care as rotating one blade can cause other blades to rotate.

## Operation

- Lightning can cause severe injury or death. If lightning is seen or thunder is heard in the area, do not operate the machine; seek shelter.
- Be alert, slow down, and use caution when making turns. Look behind and to the side before changing directions.
- Do not operate the engine in a confined space where dangerous carbon monoxide fumes can collect.
- Operate the machine in daylight or in good artificial light only.
- Before attempting to start the engine, disengage all blade attachment clutches and shift the machine into the neutral position.
- Do not use the machine on slopes greater than 15 degrees.
- There is no such thing as a safe slope. Travel on grass slopes requires particular care. To guard against overturning:
  - - do not stop or start suddenly when on a slope;
  - - use slow speeds on slopes and during tight turns;
  - - stay alert for humps and hollows and other hidden hazards;
- Use care when pulling loads or using heavy equipment.
  - - Use only approved drawbar hitch points.
  - - Limit loads to those you can safely control.
  - - Do not turn sharply. Use care when reversing.
- Watch for traffic when crossing or near roadways.
- Stop the blades before crossing surfaces other than grass.
- When using any attachments, never direct discharge of the material toward bystanders nor allow anyone near the machine while in operation.
- Never operate the machine with damaged guards or without safety protective devices in place.

- Do not change the engine governor settings or overspeed the engine. Operating the engine at excessive speed can increase the hazard of personal injury.
- Before leaving the operator's position:
  - disengage the power take-off and lower the attachments;
  - put the machine into the neutral position and set the parking brake;
  - stop the engine and remove the key.
- Disengage drive to attachments, stop the engine, and disconnect the spark plug wire(s) or remove the ignition key
  - before clearing any blockages or unclogging the chute;
  - before checking, cleaning, or working on the machine;
  - after striking a foreign object. Inspect the machine for damage and make repairs before restarting and operating the machine; if the machine starts to vibrate abnormally (check immediately).
- Disengage the drive to the attachments when transporting the machine or when the machine is not in use.
- Stop the engine and disengage the drive to the attachment
  - before refuelling;
  - before removing the grass catcher;
  - before making height adjustment unless adjustment can be made from the operator's position.
- Reduce the throttle setting during engine run-out and, if the engine is provided with a shut-off valve, turn the fuel off at the conclusion of mowing.

## Maintenance and Storage

- Keep all nuts, bolts, and screws tight to ensure that the machine is in safe working condition.
- Never store the machine that has fuel in the tank inside a building where fumes can reach an open flame or spark.
- Allow the engine to cool before storing the machine in any enclosure.
- To reduce fire hazard, keep the engine, silencer, battery compartment, and fuel storage area free of grass, leaves, or excessive grease.
- Check the grass catcher frequently for wear or deterioration.
- Replace worn or damaged parts for safety.
- Drain the fuel tank outdoors.
- On multi-bladed machines, take care as rotating one blade can cause other blades to rotate.
- When the machine is to be parked, stored, or left unattended, lower the cutting means unless a positive mechanical lock is used.

## Toro Riding Mower Safety

The following list contains safety information specific to Toro products or other safety information that you must know that is not included in the CEN standard.

- Engine exhaust contains carbon monoxide, which is an odorless, deadly poison that can kill you. Do not run an engine indoors or in an enclosed area.
- Keep your hands, feet, hair, and loose clothing away from the attachment discharge area, underside of mower, and any moving parts while engine is running.
- Do not touch the machine or attachment parts which may be hot from operation. Before attempting to maintain, adjust, or service the machine allow it to cool.
- Battery acid is poisonous and can cause burns. Avoid contact with skin, eyes, and clothing. Protect your face, eyes, and clothing when working with a battery.
- Battery gases can explode. Keep cigarettes, sparks, and flames away from batteries.
- Use only genuine Toro replacement parts to ensure that original standards are maintained.
- Use only Toro-approved attachments. The warranty may be voided if the machine is used with unapproved attachments.

## Slope Operation

- Do not mow slopes greater than 15 degrees.
- Do not mow near drop-offs, ditches, steep banks, or water. Wheels dropping over edges can cause rollovers, which may result in serious injury, death, or drowning.
- Do not mow slopes when the grass is wet. Slippery conditions reduce traction and could cause sliding and loss of control.
- Do not make sudden turns or rapid speed changes.
- Use a walk behind mower and/or a hand trimmer near drop-offs, ditches, steep banks, or water.
- Reduce the speed and use extreme caution on slopes.
- Remove or mark obstacles such as rocks, tree limbs, etc. from the mowing area. Tall grass can hide obstacles.
- Watch for ditches, holes, rocks, dips, and rises that change the operating angle, as rough terrain could overturn the machine.
- Avoid sudden starts when mowing uphill because the mower may tip backwards.
- Be aware that loss of traction may occur going downhill. Weight transfer to the front wheels may cause drive wheels to slip and cause loss of braking and steering.
- Always avoid sudden starting or stopping on a slope. If tires lose traction, disengage the blades and proceed slowly off the slope.

- Follow the manufacturer's recommendations for wheel weights or counterweights to improve stability.
- Use extreme care with grass catchers or other attachments. These can change the stability of the machine and cause loss of control.

## Sound Pressure

This unit has a sound pressure level at the operator's ear of 92 dBA, which includes an Uncertainty Value (K) of 1 dBA.

The sound pressure level was determined according to the procedures outlined in EN 836.

## Sound Power

This unit has a guaranteed sound power level of 105 dBA, which includes an Uncertainty Value (K) of 1 dBA.

The sound power level was determined according to the procedures outlined in ISO 11094.

## Vibration Level

### Hand-Arm

Measured vibration level for right hand = 2.7 m/s<sup>2</sup>

Measured vibration level for left hand = 3.3 m/s<sup>2</sup>

Uncertainty Value (K) = 1.7 m/s<sup>2</sup>

Measured values were determined according to the procedures outlined in EN 836.

### Whole Body

Measured vibration level = 0.75 m/s<sup>2</sup>

Uncertainty Value (K) = 0.38 m/s<sup>2</sup>

Measured values were determined according to the procedures outlined in EN 836.

# Slope Indicator

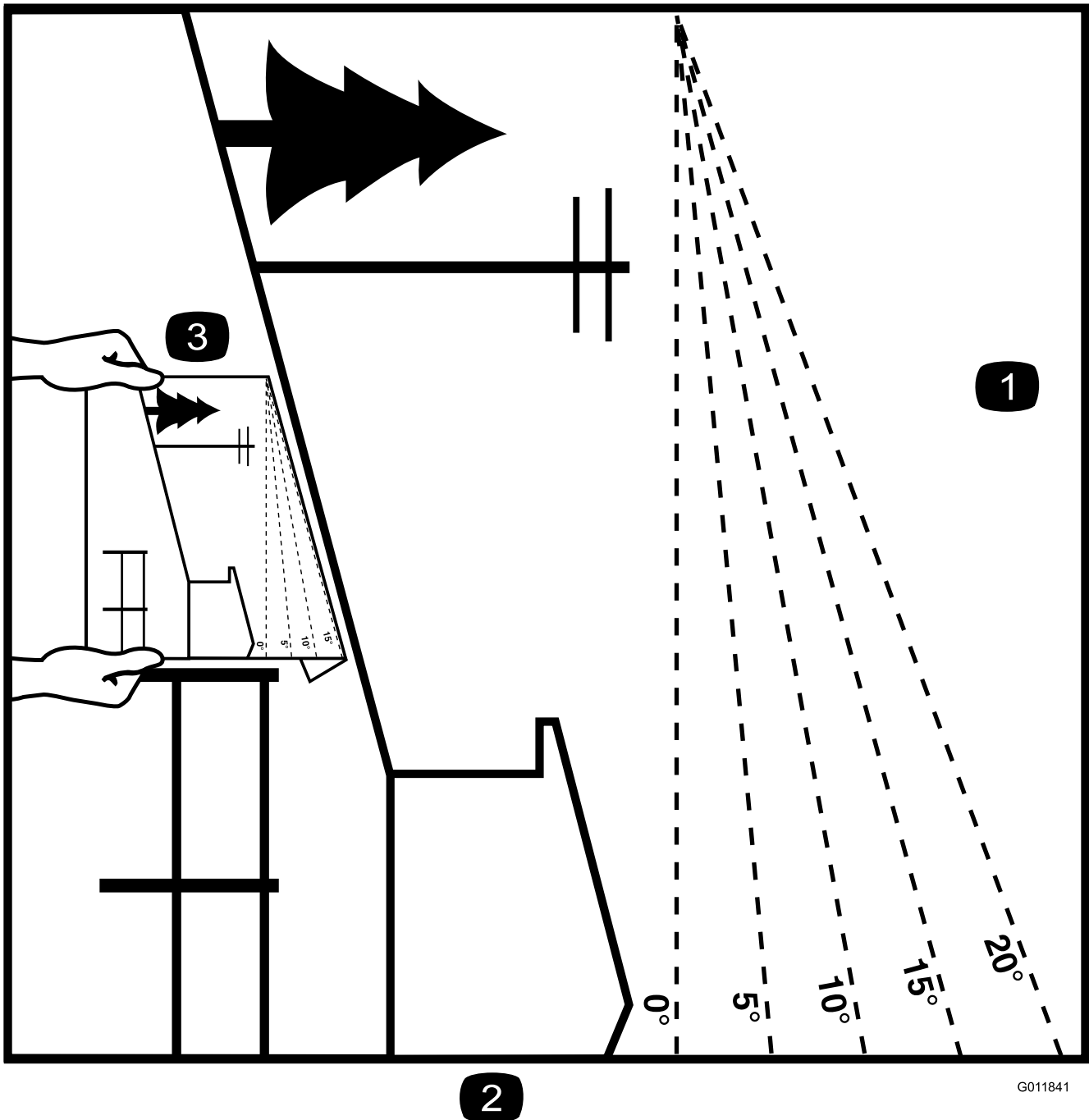

G011841

**Figure 3**

This page may be copied for personal use.

1. The maximum slope you can safely operate the machine on is **15 degrees**. Use the slope chart to determine the degree of slope of hills before operating. **Do not operate this machine on a slope greater than 15 degrees**. Fold along the appropriate line to match the recommended slope.
2. Align this edge with a vertical surface, a tree, building, fence pole, etc.
3. Example of how to compare slope with folded edge.

# Safety and Instructional Decals



Safety decals and instructions are easily visible to the operator and are located near any area of potential danger. Replace any decal that is damaged or lost.



1. Grease

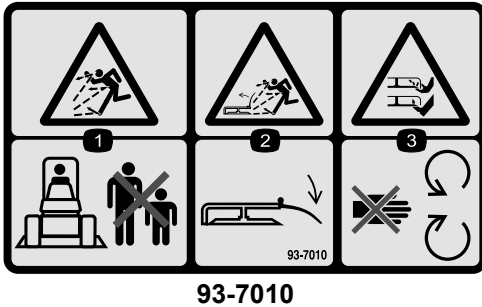

1. Thrown object hazard—keep bystanders a safe distance from the machine.
2. Thrown object hazard, mower—keep the deflector in place.
3. Cutting/dismemberment of hand or foot—stay away from moving parts.

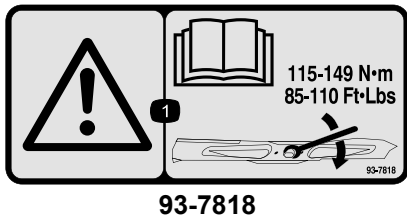

1. Warning—read the *Operator's Manual* for instructions on torquing the blade bolt/nut to 115-149 N-m (85-110 ft-lb).

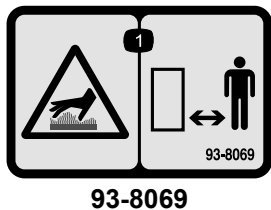

1. Hot surface/burn hazard—stay a safe distance from the hot surface.

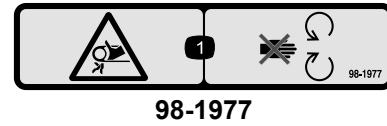

1. Entanglement hazard, belt—stay away from moving parts.



1. Warning—wear hearing protection.

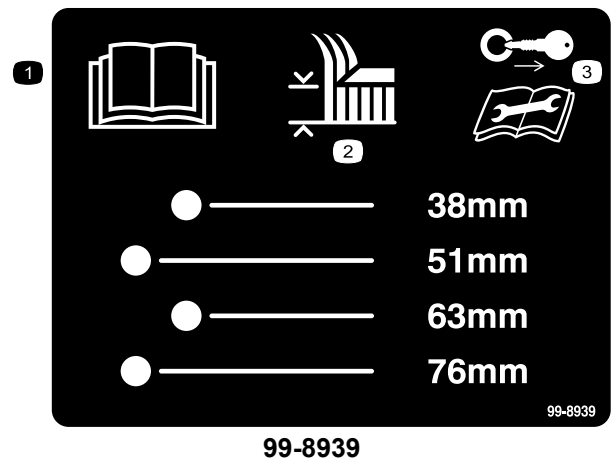

1. Read the *Operator's Manual*.
2. Height of cut
3. Remove the ignition key and read the instructions before servicing or performing maintenance.



**TORO** Landscape Contractor Equipment

THIS COOLING SYSTEM PROTECTED BY:



**Shellzone® DEX-COOL®\* Extended Life Antifreeze/Coolant**

- Top off with Shellzone® DEX-COOL®\* Extended Life Antifreeze/Coolant.
- Suggested change interval is at 4 years or 4,000 hours of service.
- Do not mix with conventional coolants.
- Ask for Shellzone® DEX-COOL®\* Extended Antifreeze/Coolant at your local auto parts store.



DEX-COOL is a registered trademark of General Motors Corp. 104-2449

104-2449



1



2



107-2131

107-2131

1. Hydraulic oil level
2. Warning—do not touch the hot surface.

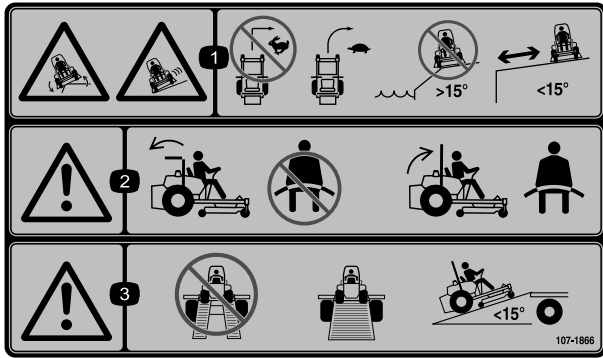

107-1866

107-1866

1. Tipping hazard and sliding or loss of control hazard, drop-offs—do not turn sharply while traveling fast, instead, slow down and turn gradually, do not operate the machine near drop-offs, slopes greater than 15 degrees, or water; keep a safe distance from drop-offs.
2. Warning—if the roll bar is lowered, do not wear the seat belt, if the roll bar is raised, wear the seat belt.
3. Warning—do not use split ramps, use a full ramps when transporting machine, only use ramps with inclines less than 15 degrees.

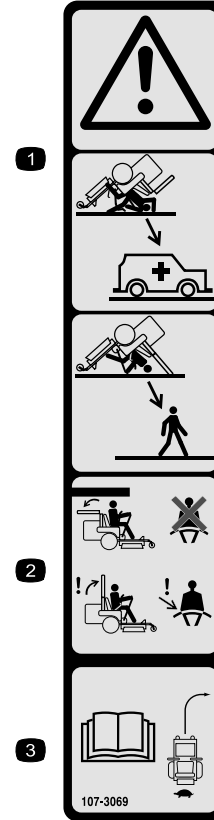

107-3069

107-3069

1. Warning—there is no rollover protection when the roll bar is down.
2. To avoid injury or death from a rollover accident, keep the roll bar in the raised and locked position and wear the seat belt. Lower the roll bar only when absolutely necessary; do not wear the the seat belt when the roll bar is down.
3. Read the *Operator's Manual*; drive slowly and carefully.

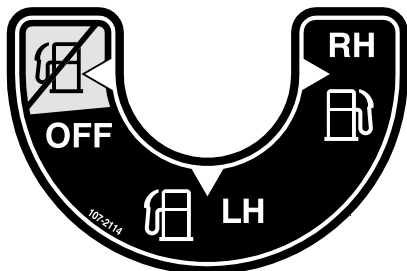

107-2114

107-2114

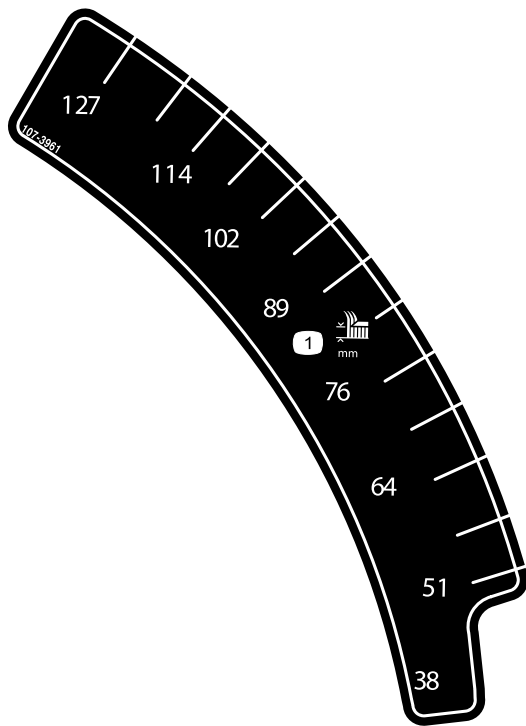

**107-3961**

1. Height of cut in millimeters

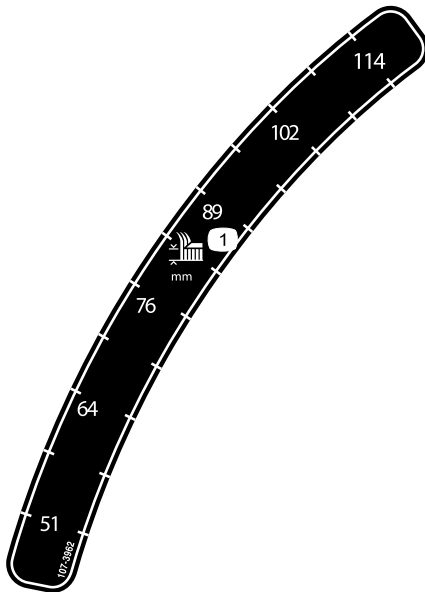

**107-3962**

1. Height of cut in millimeters

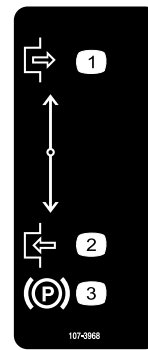

**107-3968**

1. Disengage
2. Engage
3. Parking brake

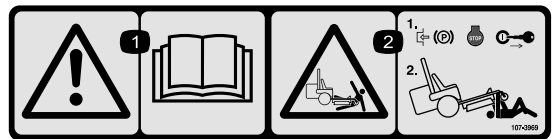

**107-3969**

1. Warning—read the *Operator's Manual*.
2. Crushing hazard, mower—engage the parking brake, stop the engine, and remove the ignition key before working under the mower.

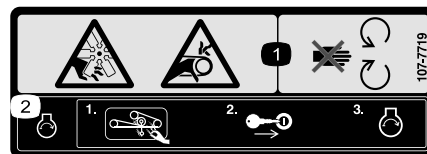

**107-7719**

1. Cutting/dismemberment hazard, fan and entanglement hazard, belt—stay away from moving parts.
2. Before starting the engine, clean grass and debris from the mower belt and pulleys, insert the ignition key, and start the engine.

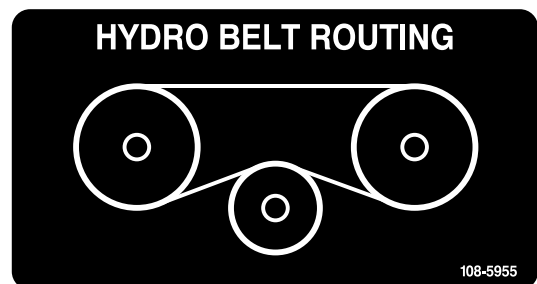

**108-5955**

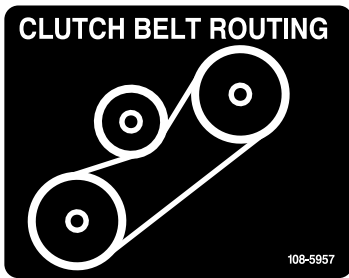

108-5957

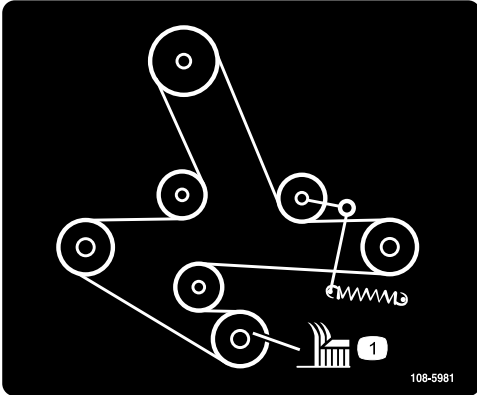

108-5981

Torque Wheel Lug Nuts to 90-95 ft-lbs (122-129 N-m). Check after first  
 Torque Wheel Hub Slotted Nut to 125 ft-lbs (169 N-m) min. 100 hrs then every  
 See Operator's Manual for more details. 500 hrs thereafter.

109-7949

**CAUTION**  
 DO NOT USE STARTING FLUID

110-0806

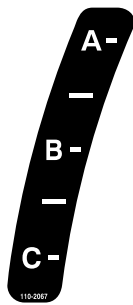

110-2067

### ADJUSTABLE BAFFLE BAFLE AJUSTABLE

<b>A -</b>	• Short, light grass • Dry conditions • Maximum dispersion			• Césped corto y ligero • Condiciones secas • Maxima dispersion
<b>B -</b>	• Bagging setting			• Posicion para usar con bolsa
<b>C -</b>	• Tall, dense grass • Wet conditions • Maximum ground speed			• Césped alto y denso • Condiciones mojadas • Maxima velocidad

110-2068

110-2068

1. Read the Operator's Manual.

**CAUTION**  
 A solution of 50% antifreeze and 50% water must be used in this engine. (Freezing point about -34°F)  
 Do not use 100% antifreeze, or severe damage will occur.

110-3842

### CHECK SERVICE REFERENCE AID

- GREASE LUBE POINTS AT INTERVALS SHOWN.
- CHECK HYDRAULIC FLUID AT INTERVAL SHOWN. (USE ONLY MOBIL 1 15W-50 SYNTHETIC MOTOR OIL.) INITIAL CHANGE OF HYDRAULIC OIL AND FILTER AT 25 HOURS, YEARLY THEREAFTER.
- SEE ENGINE OPERATOR'S MANUAL FOR SERVICING ENGINE. CHECK ENGINE OIL DAILY. USE SAE 10W-30.
- CHECK TIRE PRESSURE - 13 PSI AT INTERVAL SHOWN.
- INITIAL CHANGE AT 100 HOURS, YEARLY THEREAFTER. CHECK FLUID LEVEL AT INTERVAL SHOWN. USE SAE 75W90 SYNTHETIC GEAR LUBE.
- CHECK ENGINE COOLANT AT INTERVAL SHOWN. USE DEX-COOL EXTENDED LIFE ANTIFREEZE/COOLANT.
- CHANGE AIR FILTER ELEMENT AT 250 HOURS.
- CHANGE FUEL FILTERS AT 400 HOURS.

110-3851

110-3851

1. Remove the ignition key and read the instructions before servicing or performing maintenance.

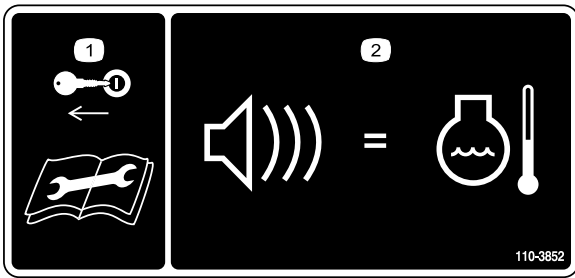

110-3852

1. Remove the ignition key and read the instructions before servicing or performing maintenance.
2. Continuous tone signals the user that engine is overheating.

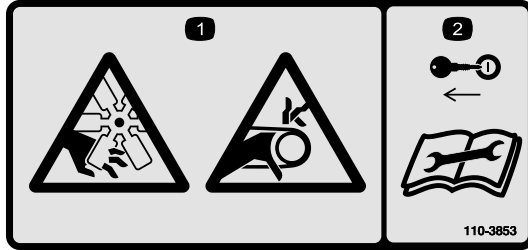

110-3853

1. Cutting/dismemberment hazard, fan and entanglement hazard, belt.
2. Remove the ignition key and read the instructions before servicing or performing maintenance.

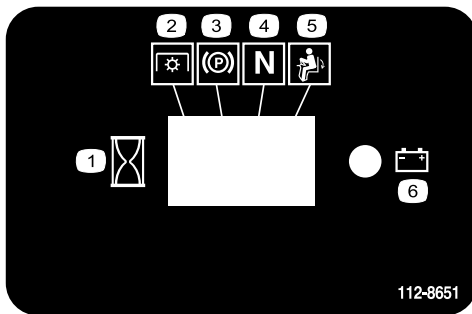

112-8651

1. Interval
2. Power Take-off (PTO)
3. Parking brake
4. Neutral
5. Operator presence switch
6. Battery

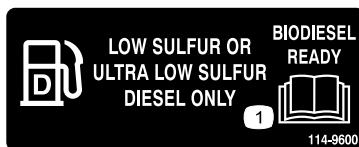

114-9600

1. Read the *Operator's Manual*.

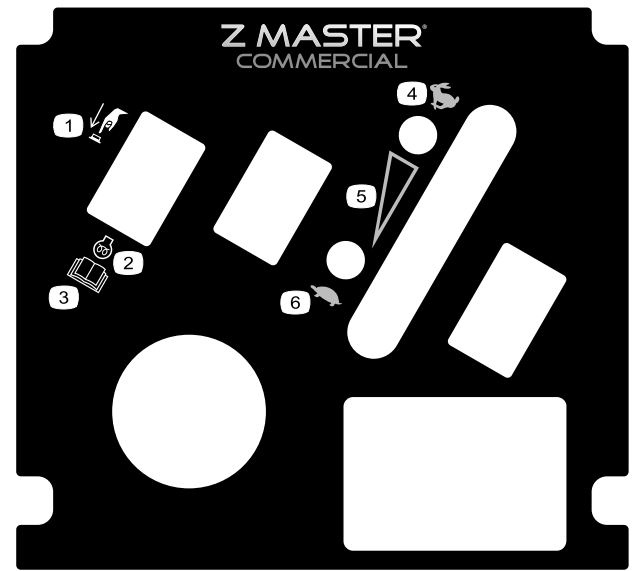

117-0912

1. Push to engage
2. Engine—preheat
3. Rear the *Operator's Manual*.
4. Fast
5. Continuous variable setting
6. Slow

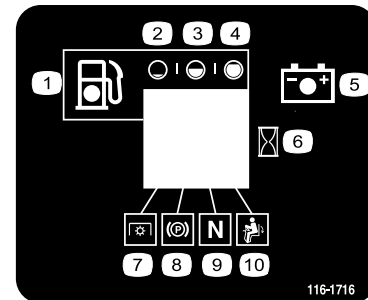

116-1716

1. Fuel
2. Empty
3. Half
4. Full
5. Battery
6. Hour meter
7. PTO
8. Parking brake
9. Neutral
10. Operator presence switch

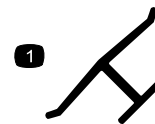

**Manufacturer's Mark**

1. Indicates the blade is identified as a part from the original machine manufacturer.



### Battery Symbols

Some or all of these symbols are on your battery

- |  |  |
|--|--|
| 1. Explosion hazard                    | 6. Keep bystanders a safe distance from the battery.                           |
| 2. No fire, open flame, or smoking.    | 7. Wear eye protection; explosive gases can cause blindness and other injuries |
| 3. Caustic liquid/chemical burn hazard | 8. Battery acid can cause blindness or severe burns.                           |
| 4. Wear eye protection                 | 9. Flush eyes immediately with water and get medical help fast.                |
| 5. Read the <i>Operator's Manual</i> . | 10. Contains lead; do not discard.   |

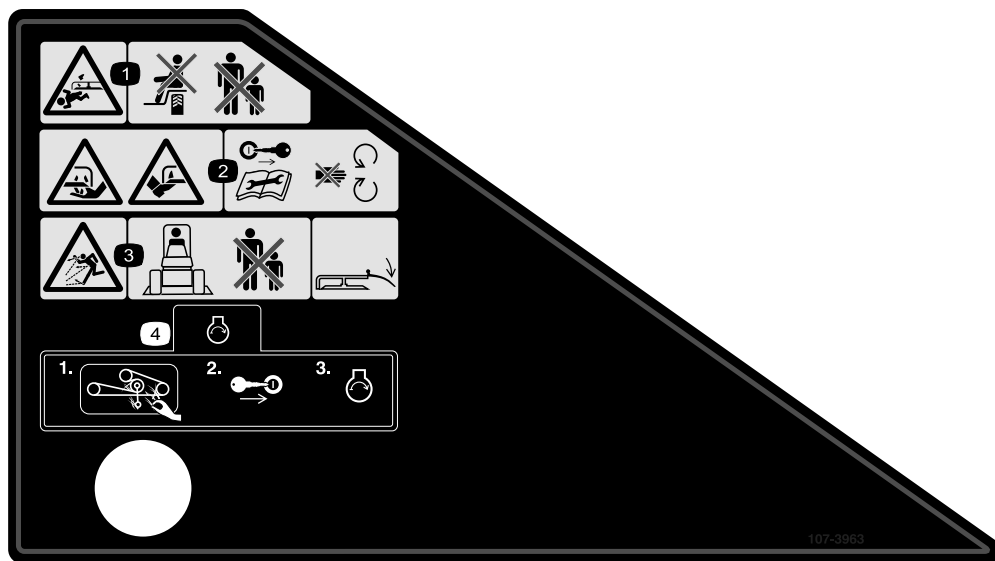

### 107-3963

- |  |   |   |   |
|--|---|---|---|
| 1. Cutting/dismemberment hazard, mower blade—do not carry passengers and keep bystanders away. | 2. Cutting/dismemberment hazard of hand or foot, mower blade—remove the ignition key and read the instructions before servicing or performing maintenance; stay away from moving parts. | 3. Thrown object hazard—keep bystanders a safe distance from the machine and keep the deflector in place. | 4. Before starting the engine, clean grass and debris from the mower belt and pulleys, insert the ignition key, and start the engine. |
|--|---|---|---|

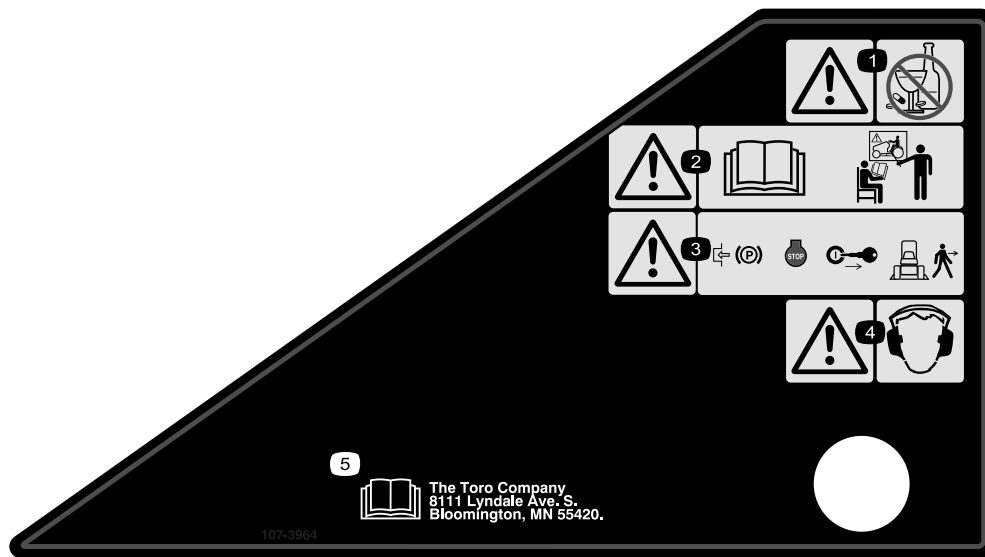

107-3964

1. Warning—do not use drugs or alcohol.
2. Warning—read the *Operator's Manual* and receive training.
3. Warning—engage the parking brake, stop the engine, and remove the ignition key before leaving the machine.
4. Warning—wear hearing protection.
5. Read the *Operator's Manual*.



110-0820

1. Fast
2. Slow
3. Neutral
4. Reverse
5. Warning—read the *Operator's Manual*.
6. Poison and caustic liquid/chemical burn hazard—keep children a safe distance from the battery.
7. Explosion hazard—no fire, open flames, or smoking; avoid sparks.
8. To unlock the traction drive, turn the by-pass valve 1 complete revolution counterclockwise using a 5/8 inch or 16 mm wrench.

# Product Overview

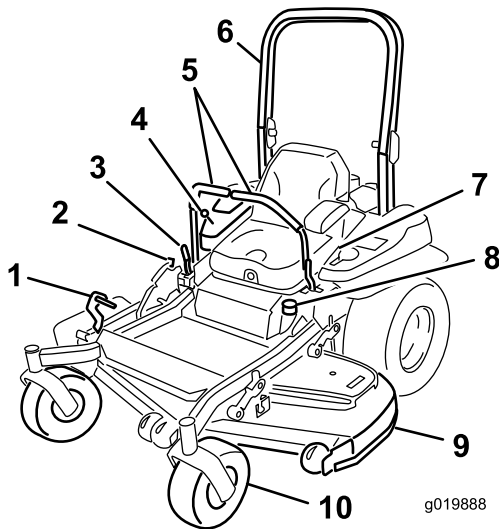

Figure 4

- |                                  |                  |
|----------------------------------|------------------|
| 1. Height-of-cut deck lift pedal | 6. Roll bar      |
| 2. Transport lock                | 7. Seat belt     |
| 3. Parking brake lever           | 8. Fuel cap      |
| 4. Controls                      | 9. Mower deck    |
| 5. Motion control lever          | 10. Caster wheel |

## Controls

Become familiar with all of the controls before you start the engine and operate the machine (Figure 4 and Figure 5).

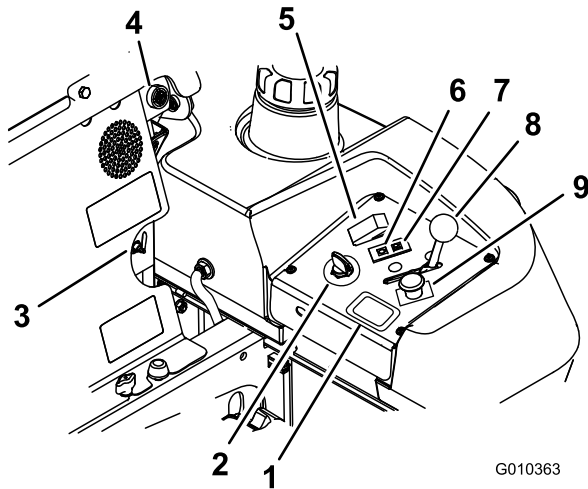

Figure 5

- |                        |                             |
|------------------------|-----------------------------|
| 1. Hour meter          | 6. Glow plug light          |
| 2. Ignition switch     | 7. Engine temperature light |
| 3. Fuel selector valve | 8. Throttle control         |
| 4. Audible alarm       | 9. PTO switch               |
| 5. Glow plug switch    |                             |

## Hour Meter

The hour meter records the number of hours the engine has operated. It operates when the engine is running. Use these times for scheduling regular maintenance (Figure 5).

## Safety Interlock Indicators

There are symbols on the hour meter and they indicate with a black triangle that the interlock component is in the correct position (Figure 6).

## Battery Indicator Light

When the ignition key is initially turned to the **Run** position for a few seconds, the battery voltage will be displayed in the area where the hours are normally displayed.

The battery light turns on when the ignition is turned on and when the charge is below the correct operating level (Figure 6).

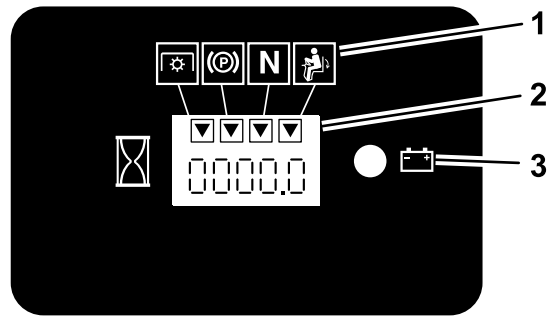

Figure 6

- |                             |                  |
|-----------------------------|------------------|
| 1. Safety interlock symbols | 3. Battery light |
| 2. Hour meter               |                  |

## Throttle Control

The throttle control is variable between **Fast** and **Slow**.

## Blade Control Switch (PTO)

The blade control switch (PTO) is used to engage the electric clutch to drive the mower blades with the motion control levers in the center, un-locked position. Pull the switch up to engage the blades and release. To disengage the blades, push the blade control switch (PTO) down.

## Neutral Lock Position

The neutral lock position is used with the safety interlock system and to determine neutral position.

## Ignition Switch

This switch is used to start the mower engine and has three positions: **Start**, **Run**, and **Off**.

## Glow Plug Light

The glow plug indicator light turns on when the glow plug button is engaged (Figure 5).

## Glow Plug Switch

This switch activates the glow plugs and is indicated by the glow plug light. Hold down the glow plug switch for 10 seconds prior to starting.

## Temperature Light

The temperature light comes on when the engine is over heating (Figure 5).

## Audible Alarm

This machine has an audible alarm that alerts the user to turn off the engine or engine damage can occur from over heating. Refer to (page ).

## Fuel Selector Valve

The fuel selector valve is located behind the seat.

Close the fuel selector valve when transporting or storing mower.

Move the selector valve to the left-hand (LH) or right-hand (RH) position for operation.

## Attachments/Accessories

A selection of Toro approved attachments and accessories is available for use with the machine to enhance and expand its capabilities. Contact your Authorized Service Dealer or Distributor or go to [www.Toro.com](http://www.Toro.com) for a list of all approved attachments and accessories.

# Operation

**Note:** Determine the left and right sides of the machine from the normal operating position.

## Adding Fuel

The engine runs on clean, fresh diesel fuel with a minimum octane rating of 40. Purchase fuel in quantities that can be used within 30 days to ensure fuel freshness.

Use summer grade diesel fuel (No. 2-D) at temperatures above -7 degrees Celsius (20 degrees Fahrenheit) and winter grade diesel fuel (No. 1-D or No. 1-D/2-D blend) below -7 degrees Celsius (20 degrees Fahrenheit). Use of winter grade diesel fuel at lower temperatures provides lower flash point and pour point characteristics, therefore easing startability and lessening chances of chemical separation of the fuel due to lower temperatures (wax appearance, which may plug filters).

Use of summer grade diesel fuel above -7 degrees Celsius (20 degrees Fahrenheit) will contribute toward longer life of the pump components.

**Important: Do not use kerosene or gasoline instead of diesel fuel. Failure to observe this caution will damage the engine.**

### **▲ WARNING**

**Fuel is harmful or fatal if swallowed. Long-term exposure to vapors can cause serious injury and illness.**

- **Avoid prolonged breathing of vapors.**
- **Keep face away from nozzle and gas tank or conditioner opening.**
- **Keep gas away from eyes and skin.**



## **▲ DANGER**

In certain conditions, fuel is extremely flammable and highly explosive. A fire or explosion from fuel can burn you and others and can damage property.

- Fill the fuel tank outdoors on level ground, in an open area, when the engine is cold. Wipe up any fuel that spills.
- Never fill the fuel tank inside an enclosed trailer.
- Do not fill the fuel tank completely full. Fill the fuel tank to the bottom of the filler neck. The empty space in the tank allows gasoline to expand. Overfilling may result in fuel leakage or damage to the engine or emission system (if equipped).
- Never smoke when handling fuel, and stay away from an open flame or where fuel fumes may be ignited by a spark.
- Store fuel in an approved container and keep it out of the reach of children. Do not buy more than a 30-day supply of fuel.
- Always place fuel containers on the ground away from your vehicle before filling.
- Do not fill fuel containers inside a vehicle or on a truck or trailer bed because interior carpets or plastic truck bed liners may insulate the container and slow the loss of any static charge.
- When practical, remove gas-powered equipment from the truck or trailer and refuel the equipment with its wheels on the ground.
- If this is not possible, then refuel such equipment on a truck or trailer from a portable container, rather than from a fuel dispenser nozzle.
- If a fuel dispenser nozzle must be used, keep the nozzle in contact with the rim of the fuel tank or container opening at all times until fueling is complete.

## **Biodiesel Ready**

This machine can also use a biodiesel blended fuel of up to B20 (20% biodiesel, 80% petrodiesel). The petrodiesel portion should be low or ultra low sulfur.

Observe the following precautions:

- The biodiesel portion of the fuel meet specification ASTM D6751 or EN14214.
- The blended fuel composition should meet ASTM D975 or EN590.

- Painted surfaces may be damaged by biodiesel blends.
- Use B5 (biodiesel content of 5%) or lesser blend in cold weather.
- Monitor seals, hoses, gaskets in contact with fuel as they may be degrade over time.
- Fuel filter plugging maybe expected for a time after converting to biodiesel blends.
- Contact your distributor if you wish for more information on biodiesel.

## **Filling the Fuel Tank**

**Note:** Do not fill the fuel tank completely full. Fill the fuel tank to the bottom of the filler neck. The empty space in the tank allows the gasoline to expand.

1. Shut the engine off and set the parking brake.
2. Clean around each fuel tank cap and remove the cap. Fill the fuel tank to the bottom of the filler neck. This space in the tank allows the fuel to expand. Do not fill the fuel tank completely full.
3. Install the fuel tank cap securely. Wipe up any fuel that may have spilled.
4. If possible, fill the fuel tank after each use. This will minimize possible buildup of condensation inside the fuel tank.

## **Checking the Engine Oil Level**

Before you start the engine and use the machine, check the oil level in the engine crankcase; refer to Checking the Engine Oil Level (page 35).

## **Switching the Fuel Tanks**

**Important:** Do not run the machine out of fuel. This may cause engine damage and require the fuel system to be checked.

The fuel selector valve is located behind the left side of the seat.

The unit has two fuel tanks. One tank is on the left side and one on the right side. Each tank connects to the fuel selector valve. From there a common fuel line leads to the engine (Figure 7).

To use the left side fuel tank rotate the fuel selector valve to the LH, left-hand location. To use the right side fuel tank rotate the fuel selector valve to the RH, right-hand location (Figure 7).

Close the fuel selector valve before transporting or storing the machine.

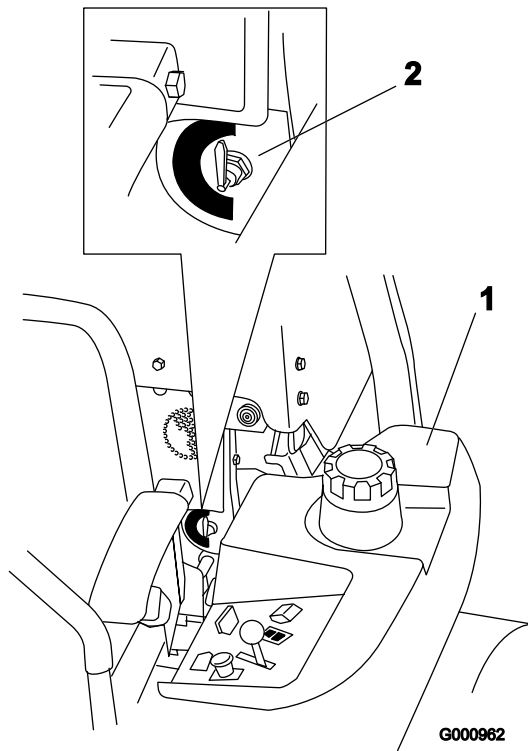

Figure 7

1. Left side fuel tank      2. Fuel selector valve

**Important:** Lower the roll bar only when absolutely necessary.

1. Remove the hairpin cotter pins and remove the 2 pins (Figure 9).
2. Lower the roll bar to the down position. There are 2 down positions. See Figure 8 for the positions.
3. Install the 2 pins and secure them with the hairpin cotter pins (Figure 9).

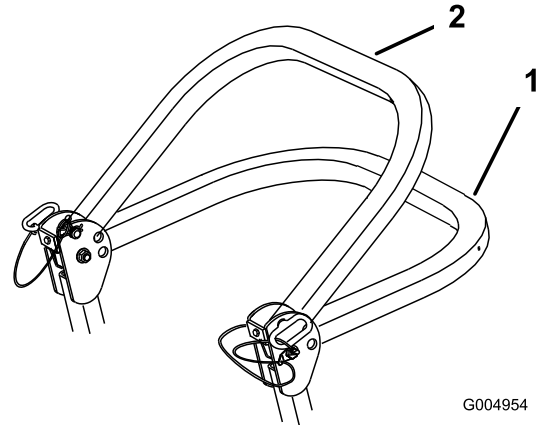

Figure 8

1. Full down position      2. Down position with bagger installed

## Using the Rollover Protection System (ROPS)

### **⚠ WARNING**

To avoid injury or death from rollover: keep the roll bar in the raised locked position and use the seat belt.

Ensure that the rear part of the seat is secured with the seat latch.

### **⚠ WARNING**

There is no rollover protection when the roll bar is in the down position.

- Lower the roll bar only when absolutely necessary.
- Do not wear the seat belt when the roll bar is in the down position.
- Drive slowly and carefully.
- Raise the roll bar as soon as clearance permits.
- Check carefully for overhead clearances (i.e. branches, doorways, electrical wires) before driving under any objects and do not contact them.

**Important:** Ensure that the rear part of the seat is secured with the seat latch.

4. To raise the roll bar, remove the hairpin cotter pins and remove the 2 pins (Figure 9).
5. Raise the roll bar to the upright position and install the 2 pins and secure them with the hairpin cotter pins (Figure 9).

**Important:** Always use the seat belt with the roll bar in the raised position.

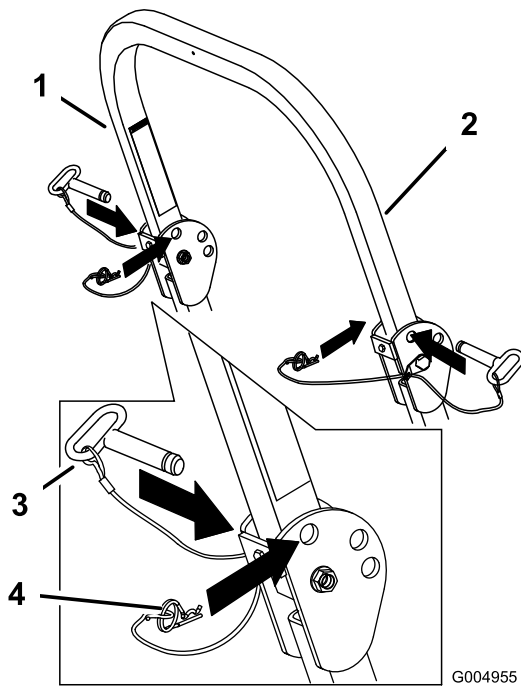

**Figure 9**

G004955

- |                    |                       |
|--------------------|-----------------------|
| 1. Roll bar        | 3. Pin                |
| 2. Raised position | 4. Hairpin cotter pin |

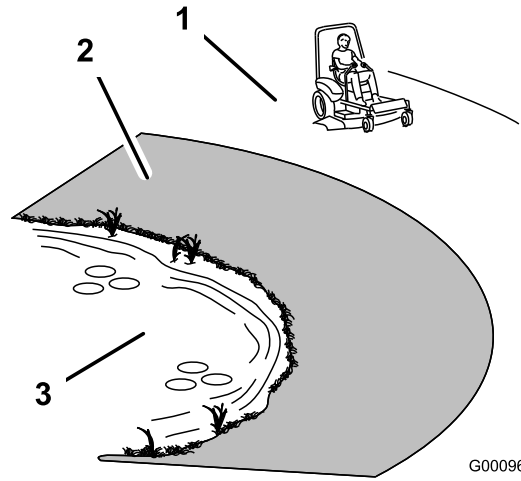

G000963

**Figure 10**

1. Safe Zone—use the Z Master here on slopes less than 15 degrees or flat areas.
2. Use walk behind mower and/or hand trimmer near drop-offs and water.
3. Water

## Think Safety First

Please read all safety instructions and symbols in the safety section. Knowing this information could help you or bystanders avoid injury.

### **▲ DANGER**

Operating on wet grass or steep slopes can cause sliding and loss of control.

Wheels dropping over edges can cause rollovers, which may result in serious injury, death or drowning.

There is no rollover protection when the roll bar is down.

Always keep the roll bar in the raised and locked position and use the seat belt.

Read and follow the rollover protection instructions and warnings.

To avoid loss of control and possibility of rollover:

- Do not operate near drop-offs or near water.
- Do not operate on slopes greater than 15 degrees.
- Reduce speed and use extreme caution on slopes.
- Avoid sudden turns or rapid speed changes.

### **▲ CAUTION**

This machine produces sound levels in excess of 85 dBA at the operators ear and can cause hearing loss through extended periods of exposure.

**Wear hearing protection when operating this machine.**

Wear protective equipment for your eyes, ears, feet, and head when using this machine.

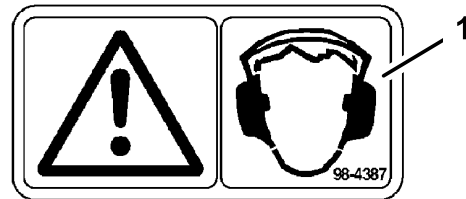

G000504

**Figure 11**

1. Warning— wear hearing protection

# Operating the Parking Brake

Always set the parking brake when you stop the machine or leave it unattended.

## Setting the Parking Brake

1. Move the motion control levers (Figure 18) out to the neutral lock position.
2. Pull up and back on the parking brake lever to set the parking brake (Figure 12). The parking brake lever should stay firmly in the engaged position.

### **⚠ WARNING**

**The parking brake may not hold the machine parked on a slope and could cause personal injury or property damage.**

**Do not park the machine on slopes unless the wheels are chocked or blocked**

## Releasing the Parking Brake

Push forward and down on the parking brake lever to release the parking brake (Figure 12). The parking brake is disengaged and the lever will rest against the brake stop.

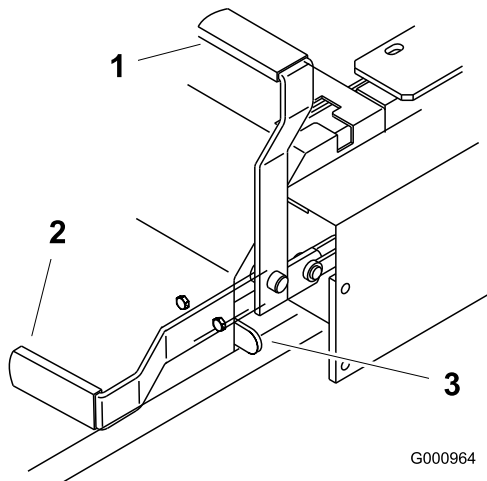

Figure 12

1. Parking brake-ON
2. Parking brake-OFF
3. Brake Stop

# Starting and Stopping the Engine

## Starting the Engine in Normal Weather

1. Raise the ROPS up and lock into place, sit on the seat and fasten the seat belt.
2. Move the motion controls to the neutral locked position.
3. Set the parking brake; refer to Setting the Parking Brake (page 20).
4. Move the PTO (power take off) switch to the off position (Figure 13).
5. Move the throttle lever to the middle position (Figure 15).
6. Turn the ignition key clockwise to the run position (Figure 14).
7. Push the glow plug switch for 10 seconds. The light will turn on.
8. Release the switch after 10 seconds. The light will turn off.

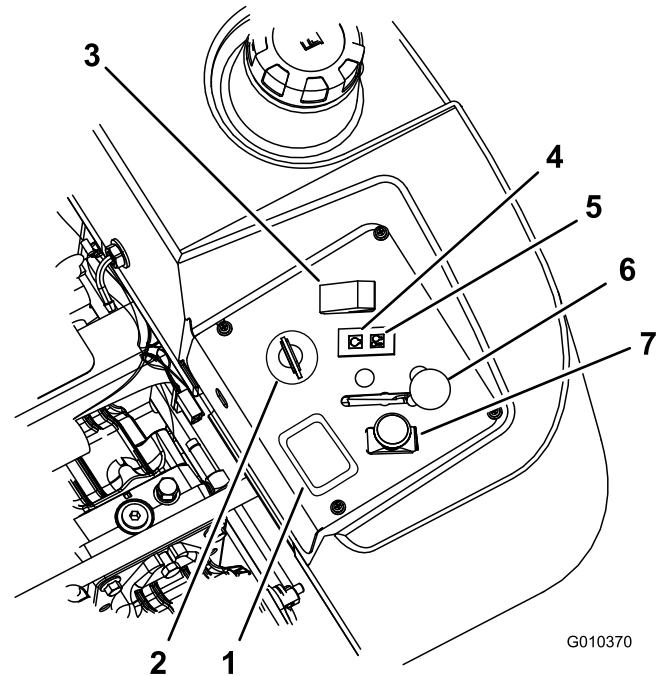

Figure 13

1. Hour meter
2. Ignition switch
3. Glow plug switch
4. Glow plug light
5. Engine Temperature light
6. Throttle control
7. PTO Switch

9. Turn the key to the start position and the glow plug indicator light will come back on. When the engine starts, release the key (Figure 14).

**Important:** Use starting cycles of no more than 30 seconds per minute to avoid overheating the starter motor.

- If the engine does not start immediately, move the throttle control to the fast position and turn the key to the start position.

**Note:** Additional starting cycles may be required when starting the engine for the first time after the fuel system has been completely without fuel.

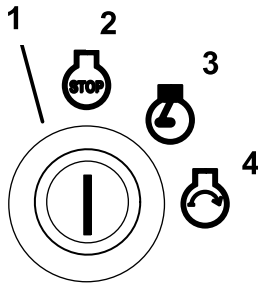

G001063

**Figure 14**

- |                    |          |
|--------------------|----------|
| 1. Ignition switch | 3. Run   |
| 2. Off             | 4. Start |

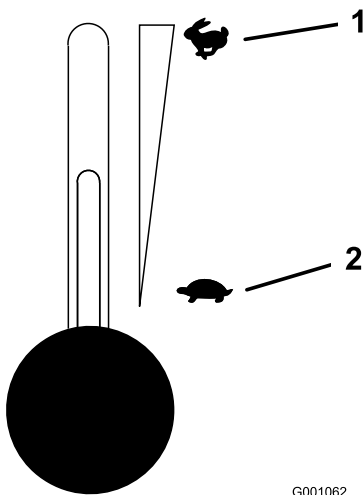

G001062

**Figure 15**

- |                  |                  |
|------------------|------------------|
| 1. Throttle—fast | 2. Throttle—slow |
|------------------|------------------|

## Starting the Engine in Cold Weather (Below 23°F or -5°C)

**Note:** Use the correct engine oil for the starting temperature. Refer to Servicing the Engine Oil (page 35).

- Start the engine with the throttle in the **Fast** position.
- Turn the ignition key clockwise to the run position (Figure 14).
- Push the glow plug switch for 10 to 15 seconds. The light will turn on.

- Release the switch after 10 to 15 seconds. The light will turn off.
- Turn the key to the start position and the glow plug indicator light will come back on. When the engine starts, release the key.

**Important:** Use starting cycles of no more than 30 seconds per minute to avoid overheating the starter motor.

**Note:** Do not use fuel left over from the summer. Use only fresh winter grade diesel fuel.

## Stopping the Engine

- Disengage the PTO, move the motion control levers to the neutral locked position and set the parking brake (Figure 16).
- Move the throttle lever midway between the slow and fast positions (Figure 15).
- Let the engine idle for 60 seconds.
- Turn the ignition key to the off position (Figure 14). Wait for all moving parts to stop before leaving the operating position.
- Remove the key to prevent possibility of someone accidentally starting the machine before transporting or storing machine.
- Close the fuel selector valve before transporting or storing the machine.

**Important:** Make sure that the fuel selector valve is closed before transporting or storing the machine, as fuel leakage may occur. Set the parking brake before transporting.

**Important:** Make sure to remove the key as the fuel pump may run and cause the battery to lose charge.

### **CAUTION**

Children or bystanders may be injured if they attempt to move or operate the machine while it is unattended.

Always remove the ignition key and set the parking brake when leaving the machine unattended, even if just for a few minutes.

# Operating the Power Take Off (PTO)

The power take off (PTO) switch starts and stops the mower blades and any powered attachments.

## Engaging the PTO

1. If the engine is cold, allow the engine to warm up 5 to 10 minutes before engaging the PTO.
2. While seated in the seat, release the pressure on the traction control levers and place it in the neutral position.
3. Place the throttle in the fast position.

**Note:** Engaging the PTO with the throttle at the half or less position will cause excessive wear to the drive belts.

4. Pull out on the power take off (PTO) switch to engage it (Figure 16).

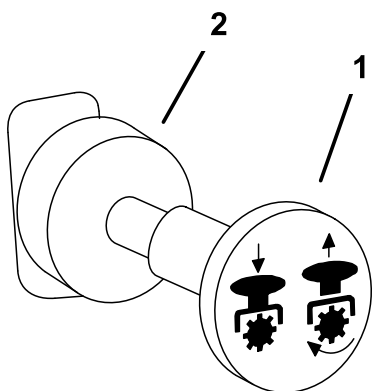

G000937

Figure 16

1. PTO-On

2. PTO-Off

## Disengaging the PTO

To disengage, push the PTO switch to the **off** position (Figure 16).

## The Safety Interlock System

### ⚠ CAUTION

If safety interlock switches are disconnected or damaged the machine could operate unexpectedly causing personal injury.

- Do not tamper with the interlock switches.
- Check the operation of the interlock switches daily and replace any damaged switches before operating the machine.

## Understanding the Safety Interlock System

The safety interlock system is designed to prevent the engine from starting unless:

- The parking brake is engaged.
- The power take off (PTO) is disengaged.
- The motion control levers are in the neutral locked position.

The safety interlock system also is designed to stop the engine when the traction controls are moved from the locked position with the parking brake engaged or if you rise from the seat when the PTO is engaged.

The hour meter has symbols to notify the user when the interlock component is in the correct position. When the component is in the correct position, a triangle will light up in the corresponding square.

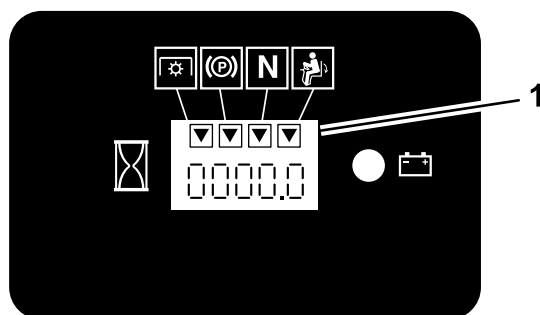

G009612

Figure 17

1. Triangles light up when the interlock components are in the correct position

## Testing the Safety Interlock System

**Service Interval:** Before each use or daily

Test the safety interlock system before you use the machine each time. If the safety system does not operate as described below, have an Authorized Service Dealer repair the safety system immediately.

1. Sit on the seat, engage the parking brake, and move the PTO to on. Try starting the engine; the engine should not crank.
2. Sit on the seat, engage the parking brake, and move the PTO to off. Move either motion control lever (out of neutral locked position). Try starting the engine; the engine should not crank. Repeat for the other control lever.
3. Sit on the seat, engage the parking brake, move the PTO switch to off, and move the motion control levers to neutral lock position. Start the engine. While the engine is running, release the parking brake, engage

the PTO, and rise slightly from the seat; the engine should stop.

4. Sit on the seat, engage the parking brake, move the PTO switch to off, and move the motion control levers to neutral lock position. Start the engine. While the engine is running, center either motion control and move (forward or reverse); the engine should stop. Repeat for the other motion control.
5. Sit on the seat, disengage the parking brake, move the PTO switch to off, and move the motion control levers to neutral lock position. Try starting the engine; the engine should not crank.

## Driving Forward or Backward

The throttle control regulates the engine speed as measured in rpm (revolutions per minute). Place the throttle control in the fast position for best performance. Always operate in the full throttle position when mowing.

### ⚠ CAUTION

The machine can spin very rapidly. The operator may lose control of the machine and cause personal injury or damage to the machine.

- Use caution when making turns.
- Slow the machine down before making sharp turns.

### Driving Forward

1. Release the parking brake; refer to Releasing the Parking Brake (page 20).
2. Move the levers to the center, un-locked position.
3. To go forward, slowly push the motion control levers forward (Figure 18).

**Note:** The engine will shut off if the traction control levers are moved with the parking brake engaged.

To go straight, apply equal pressure to both motion control levers (Figure 18).

To turn, move the motion control lever toward neutral in the direction you want to turn (Figure 18).

The farther you move the traction control levers in either direction, the faster the machine will move in that direction.

To stop, pull the motion control levers to the neutral position.

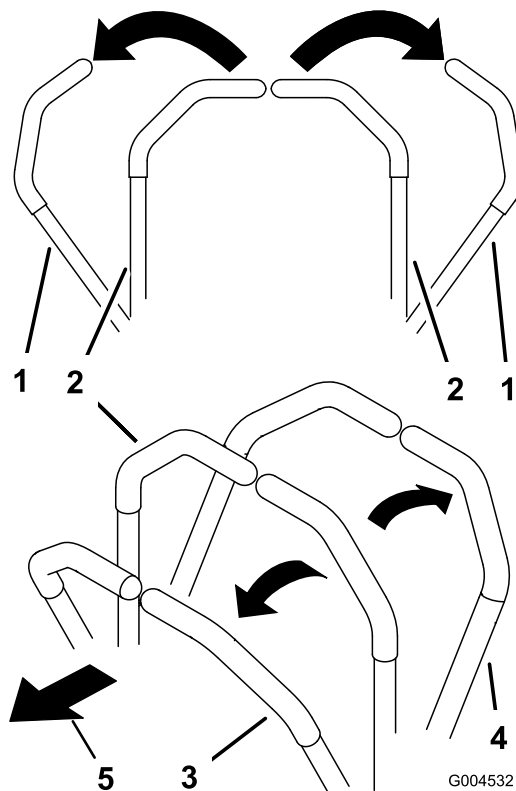

Figure 18

1. The motion control lever in the neutral lock position.
2. Center un-lock position
3. Forward
4. Backward

### Driving Backward

1. Move the levers to the center, un-locked position.
2. To go backward, slowly pull the motion control levers rearward (Figure 18).

To go straight, apply equal pressure to both motion control levers (Figure 18).

To turn, release pressure on the motion control lever toward the direction you want to turn (Figure 18).

To stop, push the motion control levers to the neutral position.

## Stopping the Machine

To stop the machine, move the traction control levers to neutral and move to locked position, disengage the power take off (PTO), and turn the ignition key to off.

Set the parking brake when you leave the machine; refer to Setting the Parking Brake (page 20). Remove the key from the ignition switch.

## ⚠ CAUTION

Children or bystanders may be injured if they attempt to move or operate the machine while it is unattended.

Always remove the ignition key and set the parking brake when leaving the machine unattended, even if just for a few minutes.

## Adjusting the Height-of-Cut

The height-of-cut is adjusted from 38 to 127 mm (1-1/2 to 5 inch) in 6 mm (1/4 inch) increments by relocating the pin into different hole locations.

1. Raise the height-of-cut lever to the transport position (also the 127 mm (5 inch) cutting height position) (Figure 19).

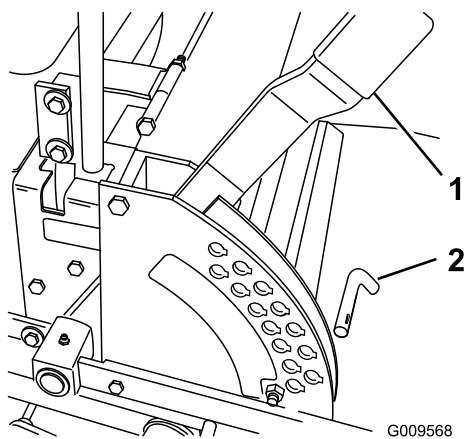

Figure 19

1. Height of cut lever
2. Pin

2. To adjust, remove the pin from the height-of-cut bracket (Figure 19).
3. Select a hole in the height-of-cut bracket corresponding to the height-of-cut desired and, insert the pin (Figure 19).
4. Move the lever to the selected height.

## Adjusting the Anti-Scalp Rollers

Whenever you change the height-of-cut, it is recommended to adjust the height of the anti-scalp rollers.

1. Disengage the PTO, move the motion control levers to the neutral locked position, and set the parking brake.
2. Stop the engine, remove the key, and wait for all moving parts to stop before leaving the operating position.
3. After adjusting the height-of-cut, adjust the rollers by removing the flange nut, bushing, spacer, and bolt (Figure 20, Figure 21, and Figure 22).

**Note:** The two middle rollers will not have a spacer (Figure 21).

4. Select a hole so that the anti-scalp roller is positioned to the nearest corresponding height-of-cut desired.
5. Install the flange nut, bushing, spacer, and bolt. Torque to 54-61 N-m (40-45 ft-lb) (Figure 20, Figure 21, and Figure 22).
6. Repeat this adjustment on the other anti-scalp rollers.

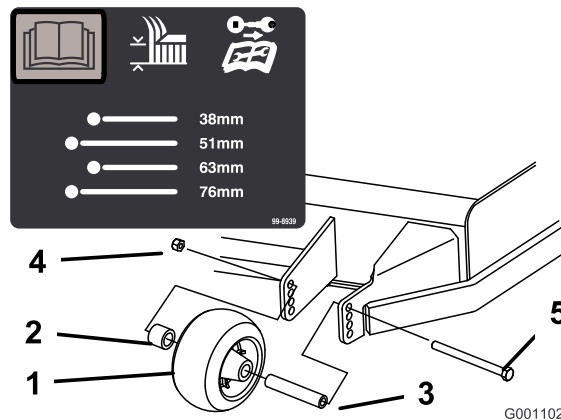

Figure 20

1. Anti-scalp roller
2. Spacer
3. Bushing
4. Flange Nut
5. Bolt

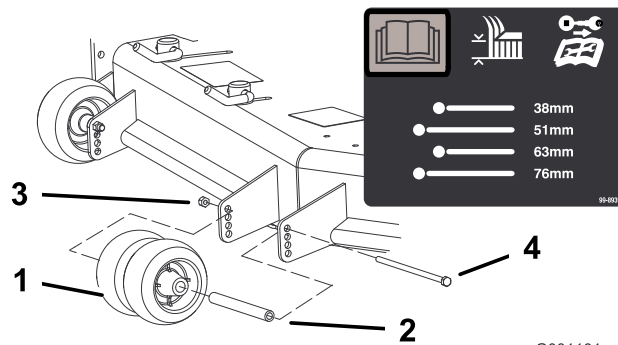

Figure 21

1. Anti-scalp roller
2. Bushing
3. Flange Nut
4. Bolt



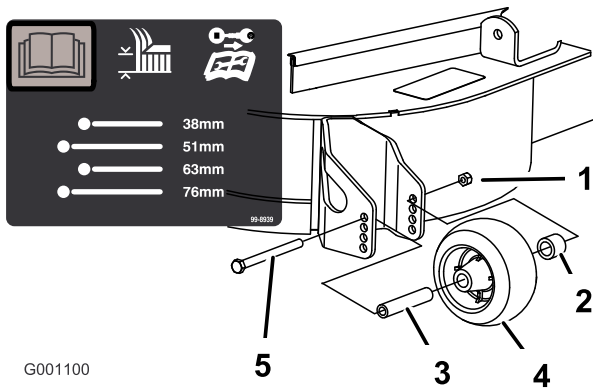

Figure 22

- |                      |               |
|----------------------|---------------|
| 1. Anti-scalp roller | 4. Flange Nut |
| 2. Spacer            | 5. Bolt       |
| 3. Bushing           |               |

## Adjusting the Flow Baffle

The mower discharge flow can be adjusted for different types of mowing conditions. Position the cam locks and baffle to give the best quality of cut.

1. Disengage the PTO, move the motion control levers to the neutral locked position, and set the parking brake.
2. Stop the engine, remove the key, and wait for all moving parts to stop before leaving the operating position.
3. To adjust the cam locks, swing the lever up to loosen the cam lock (Figure 23).
4. Adjust the baffle and cam locks in the slots to the desired discharge flow.
5. Swing the lever back over to tighten the baffle and cam locks (Figure 23).
6. If the cams do not lock the baffle into place or if it is too tight, loosen the lever and rotate the cam lock. Adjust the cam lock until the desired locking pressure is achieved.

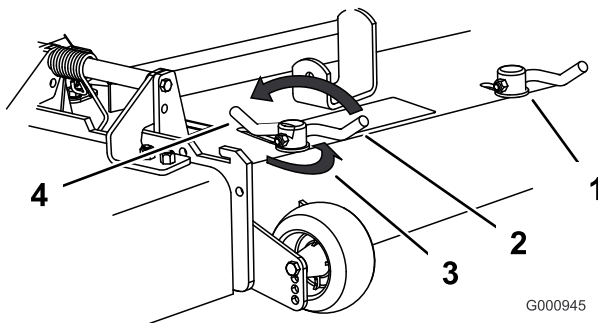

Figure 23

- |             |   |
|-------------|---|
| 1. Cam lock | 3. Rotate the cam to increase or decrease the locking pressure. |
| 2. Lever    | 4. Slot   |

## Positioning the Flow Baffle

The following figures are only recommendations for use. Adjustments will vary by grass type, moisture content, and height of grass.

**Note:** If the engine power draws down and the mower ground speed is the same, open up the baffle.

### Position A

This is the full rear position. The suggested use for this position is as follows (Figure 24).

- Use for short, light grass mowing conditions.
- Use in dry conditions.
- For smaller grass clippings.
- Propels grass clippings farther away from the mower.

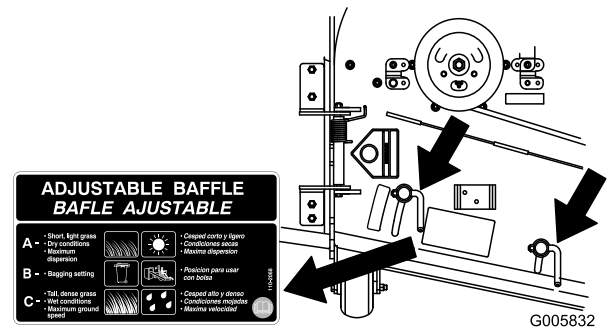

Figure 24

### Position B

Use this position when bagging.

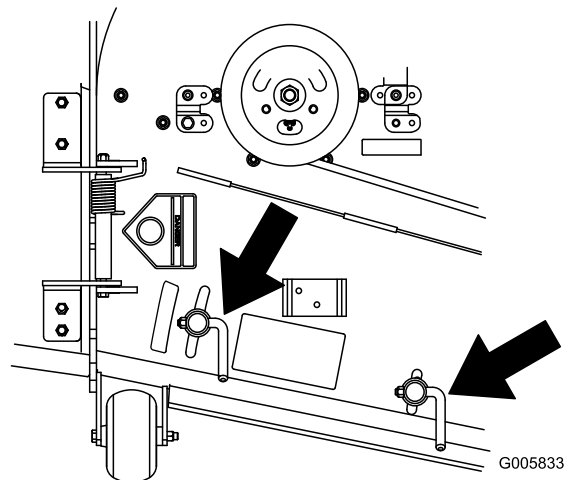

Figure 25

## Position C

This is the full open position. The suggested use for this position is as follows.

- Use in tall, dense grass mowing conditions.
- Use in wet conditions.
- Lowers the engine power consumption.
- Allows increased ground speed in heavy conditions.
- This position is similar to the benefits of the Toro SFS mower.

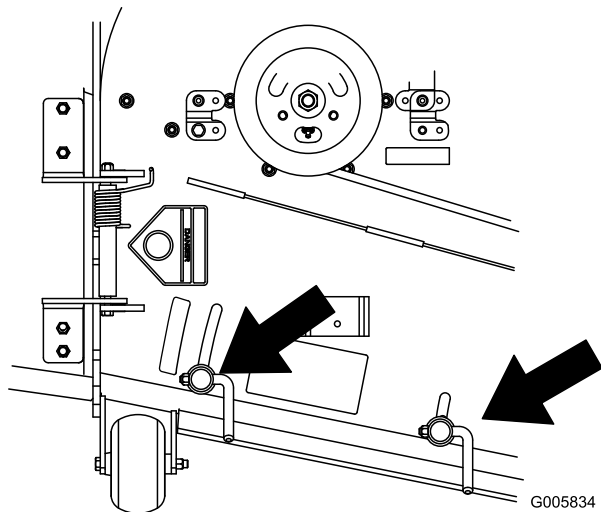

Figure 26

## Using the Lift Assist Lever

The lift assist lever is used along with the height-of-cut lever for raising the mower deck. This allows for easier raising of the mower deck.

1. Place your foot onto lift assist lever.
2. Press on the lift assist lever while pulling up on the height-of-cut lever (Figure 27).

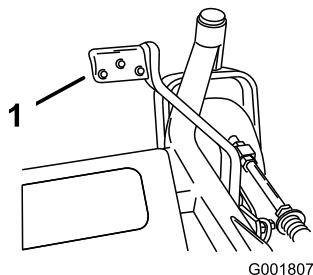

Figure 27

1. Lift assist lever

## Positioning the Seat

The seat can move forward and backward. Position the seat where you have the best control of the machine and are most comfortable.

To adjust the seat, move the lever sideways to unlock it (Figure 28).

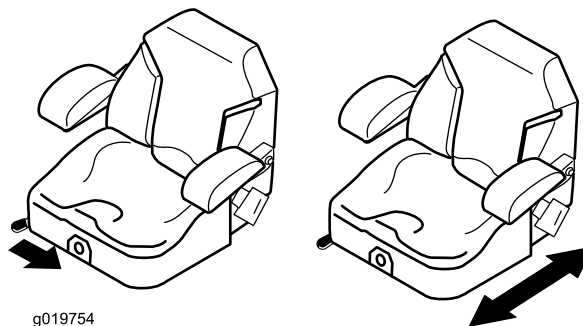

Figure 28

## Changing the Seat Suspension

The seat is adjustable to provide a smooth and comfortable ride. Position the seat where you are most comfortable.

To adjust it the seat, turn the knob in front either direction to provide the best comfort (Figure 29).

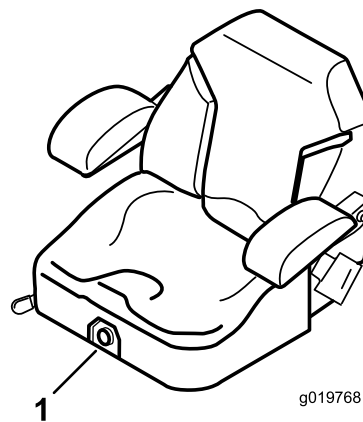

Figure 29

1. Seat suspension knob

# Unlatching the Seat

1. Move the seat to the most rearward position. This will prevent interference when the seat is raised.
2. Push the seat latch rearward to unlatch the seat.
3. Raise the seat up. This will allow access to the machine under the seat (Figure 30).

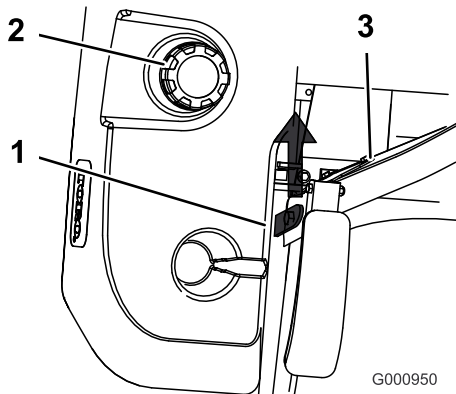

Figure 30

1. Seat latch
2. Fuel cap
3. Seat

# Pushing the Machine by Hand

**Important:** Always push the machine by hand. Never tow the machine because hydraulic damage may occur.

## Pushing the Machine

1. Disengage the power take off (PTO) and turn the ignition key to the off position. Move the levers to the neutral locked position and apply the parking brake. Remove the key.
2. Rotate the by-pass valves counterclockwise 1 turn. This allows hydraulic fluid to by-pass the pump enabling the wheels to turn (Figure 31).

**Important:** Do not rotate the by-pass valves more than 1 turn. This prevents the valves from coming out of the body and causing fluid to run out.

3. Disengage the parking brake before pushing the machine.

## Changing to Machine Operation

Rotate the by-pass valves clockwise 1 turn to operate machine (Figure 31).

**Note:** Do not over tighten the by-pass valves.

The machine will not drive unless the by-pass valves are turned in.

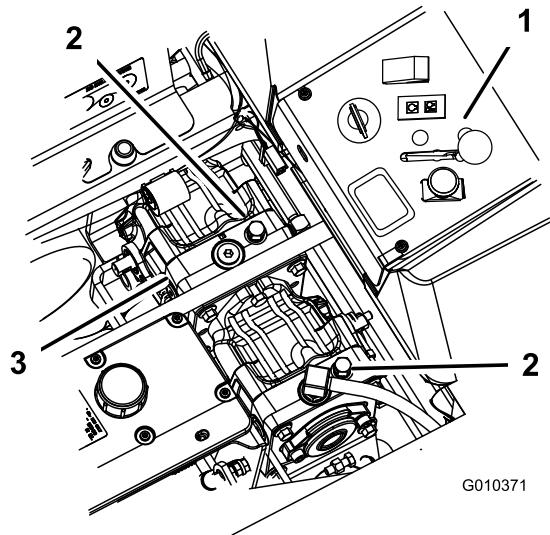

Figure 31

1. Side console controls
2. By-pass valve
3. Hydraulic pumps

# Using the Side Discharge

The mower has a hinged grass deflector that disperses clippings to the side and down toward the turf.

## **⚠ DANGER**

Without the grass deflector, discharge cover, or complete grass catcher assembly mounted in place, you and others are exposed to blade contact and thrown debris. Contact with rotating mower blade(s) and thrown debris will cause injury or death.

- Never remove the grass deflector from the mower because the grass deflector routes material down toward the turf. If the grass deflector is ever damaged, replace it immediately.
- Never put your hands or feet under the mower.
- Never try to clear the discharge area or mower blades unless you move the power take off (PTO) to the off position, rotate the ignition key to off and remove the key.
- Make sure that the grass deflector is in the down position.

# Operating with the Overheat Sensor

This machine has a sensor that will turn off the mower deck when the engine overheats. When the engine overheats, the audible alarm and light alarm will turn on along with the mower deck turning off.

If the mower deck turns off automatically because of overheating, the operator will be able to drive the machine to a safe area and to a truck or trailer.

If the machine overheats, ensure that the area around the engine and radiator is clear of any debris. The engine will need to be turned off and allowed to cool down before the mower deck can be engaged. If the engine continues to overheat, take your machine to an Authorized Service Dealer.

## Transporting Machines

Use a heavy-duty trailer or truck to transport the machine. Ensure that the trailer or truck has all necessary lighting and marking as required by law. Thoroughly read all of the safety instructions. Knowing this information could help you, your family, pets, or bystanders avoid injury.

To transport the machine:

- Lock the brake and block the wheels.
- Securely fasten the machine to the trailer or truck with straps, chains, cable, or ropes.
- Secure a trailer to the towing vehicle with safety chains.

### ⚠ WARNING

**Driving on the street or roadway without turn signals, lights, reflective markings, or a slow moving vehicle emblem is dangerous and can lead to accidents causing personal injury.**

**Do not drive machine on a public street or roadway.**

## Loading Machines

Use extreme caution when loading units on trailers or trucks. One full width ramp that is wide enough to extend beyond the rear tires is recommended instead of individual ramps for each side of the unit (Figure 32). The lower rear section of the machine frame extends back between the rear wheels and serves as a stop for tipping backward. Having a full width ramp provides a surface for the frame members to contact if the unit starts to tip backward. If it is not possible to use one full width ramp, use enough individual ramps to simulate a full width continuous ramp.

The ramp should be long enough so that the angles do not exceed 15 degrees (Figure 32). A steeper angle may cause mower components to get caught as the unit moves from ramp to trailer or truck. Steeper angles may also cause the

unit to tip backward. If loading on or near a slope, position the trailer or truck so it is on the down side of the slope and the ramp extends up the slope. This will minimize the ramp angle. The trailer or truck should be as level as possible.

**Important: Do not attempt to turn the unit while on the ramp; you may lose control and drive off the side.**

Avoid sudden acceleration when driving up a ramp and sudden deceleration when backing down a ramp. Both maneuvers can cause the unit to tip backward.

### ⚠ WARNING

**Loading a unit onto a trailer or truck increases the possibility of backward tip-over and could cause serious injury or death.**

- Use extreme caution when operating a unit on a ramp.
- Use only a single, full width ramp; Do not use individual ramps for each side of the unit.
- If individual ramps must be used, use enough ramps to create an unbroken ramp surface wider than the unit.
- Do not exceed a 15 degree angle between ramp and ground or between ramp and trailer or truck.
- Avoid sudden acceleration while driving unit up a ramp to avoid tipping backward.
- Avoid sudden deceleration while backing unit down a ramp to avoid tipping backward.

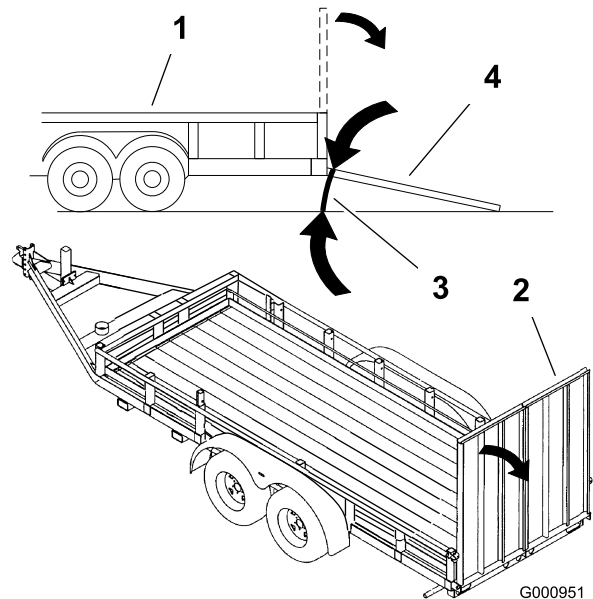

Figure 32

- 1. Trailer
- 2. Full width ramp
- 3. Not greater than 15 degrees
- 4. Full width ramp—side view

# Using the Z Stand®

The Z Stand® raises the front end of the machine to allow you to clean the mower and remove the blades.

## ⚠ WARNING

The machine could fall onto someone and cause serious injury or death.

- Use extreme caution when operating the machine on the Z Stand®.
- Use only for cleaning the mower and removing the blades.
- Do not keep the machine on the Z Stand for extended periods of time.
- Always turn the engine off, set the parking brake, and remove the key before performing any maintenance to the mower.

## Driving up onto the Z Stand

**Important:** Use the Z Stand on a level surface.

1. Raise the mower to the transport position.
2. Remove the bracket pin (Figure 33).

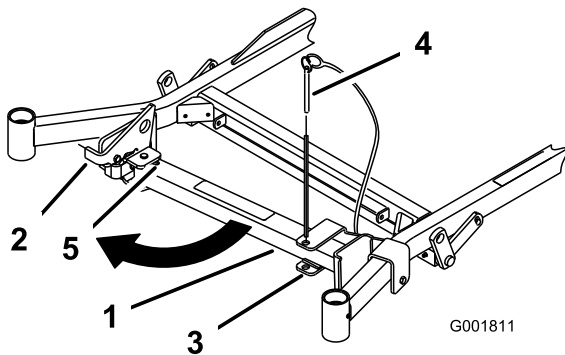

Figure 33

- |            |                   |
|------------|-------------------|
| 1. Z Stand | 4. Bracket Pin    |
| 2. Latch   | 5. Bottom of slot |
| 3. Bracket |                   |

3. Raise the latch. Swing the stand foot out front and slide stand toward machine, into the bottom of slot (Figure 33 and Figure 34).
4. Lengthen the Z Stand by removing the clevis pin and hairpin cotter pin from the outer tube and sliding the foot out.
5. Align the holes and install the clevis pin and hairpin cotter pin.

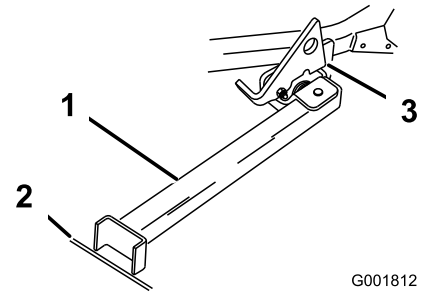

Figure 34

G001812

1. Z Stand (Positioned in slot)
  2. Crack in side walk or turf
  3. Latch resting on pivot tab slot
- 
6. Set the foot of stand on the ground and rest the latch on the pivot tab (Figure 34).
  7. Start the engine and put it at half throttle.
- Note:** For best results, place the foot of stand into seams in sidewalks or into the turf (Figure 34).
8. Drive onto the stand. Stop when the latch drops over the tab into the locked position (Figure 34). Once onto the stand, engage the parking brake and turn off the engine.
  9. Chock or block the drive wheels.

## ⚠ WARNING

The parking brake may not hold the machine that is parked on the Z Stand and could cause personal injury or property damage.

Do not park on the Z Stand unless wheels are chocked or blocked.

10. Perform the maintenance.

## Driving off of the Z Stand

1. Remove the chocks or blocks.
2. Raise the latch to the unlocked position (Figure 35).

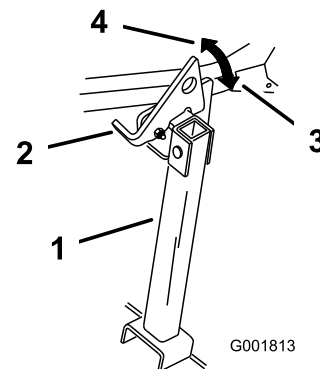

Figure 35

G001813

- |            |                      |
|------------|----------------------|
| 1. Z Stand | 3. Locked position   |
| 2. Latch   | 4. Unlocked position |

3. Start the engine and place it at half throttle. Disengage the parking brake.
4. Slowly drive backwards off of the stand.
5. Shorten the Z Stand by removing the clevis pin and hairpin cotter pin from the outer tube and sliding the foot in.
6. Align the holes and install the clevis pin and hairpin cotter pin.
7. Return the stand to its rest position (Figure 33).

## Operating Tips

### Fast Throttle Setting

For best mowing and maximum air circulation, operate the engine at the fast throttle position. Air is required to thoroughly cut grass clippings, so do not set the height-of-cut so low as to totally surround the mower by uncut grass. Always try to have one side of the mower free from uncut grass, which allows air to be drawn into the mower.

### Cutting a Lawn for the First Time

Cut grass slightly longer than normal to ensure the cutting height of the mower does not scalp any uneven ground. However, the cutting height used in the past is generally the best one to use. When cutting grass longer than six inches tall, you may want to cut the lawn twice to ensure an acceptable quality of cut.

### Cut 1/3 of the Grass Blade

It is best to cut only about 1/3 of the grass blade. Cutting more than that is not recommended unless grass is sparse, or it is late fall when grass grows more slowly.

### Mowing Direction

Alternate mowing direction to keep the grass standing straight. This also helps disperse clippings which enhances decomposition and fertilization.

### Mow at Correct Intervals

Normally, mow every four days. Grass grows at different rates at different times. To maintain the same cutting height, which is a good practice, mow more often in early spring. As the grass growth rate slows in mid summer, mow less frequently. If you cannot mow for an extended period, first mow at a high cutting height; then mow again two days later at a lower height setting.

### Cutting Speed

To improve cut quality, use a slower ground speed in certain conditions.

## Avoid Cutting Too Low

If the cutting width of the mower is wider than the mower you previously used, raise the cutting height to ensure that uneven turf is not cut too short.

## Long Grass

If the grass is ever allowed to grow slightly longer than normal, or if it contains a high degree of moisture, raise the cutting height higher than usual and cut the grass at this setting. Then cut the grass again using the lower, normal setting.

## When Stopping

If the machine's forward motion must be stopped while mowing, a clump of grass clippings may drop onto your lawn. To avoid this, move onto a previously cut area with the blades engaged.

## Keep the Underside of the Mower Clean

Clean clippings and dirt from the underside of the mower after each use. If grass and dirt build up inside the mower, cutting quality will eventually become unsatisfactory.

## Blade Maintenance

Maintain a sharp blade throughout the cutting season because a sharp blade cuts cleanly without tearing or shredding the grass blades. Tearing and shredding turns grass brown at the edges, which slows growth and increases the chance of disease. Check the cutter blades daily for sharpness, and for any wear or damage. File down any nicks and sharpen the blades as necessary. If a blade is damaged or worn, replace it immediately with a genuine TORO replacement blade.

# Maintenance

## Recommended Maintenance Schedule(s)

Maintenance Service Interval	Maintenance Procedure
After the first 8 hours	<ul style="list-style-type: none"> <li>• Check the engine cooling system level.</li> <li>• Check the hydraulic fluid level.</li> </ul>
After the first 25 hours	<ul style="list-style-type: none"> <li>• Change the hydraulic filter.</li> </ul>
After the first 50 hours	<ul style="list-style-type: none"> <li>• Change the engine oil.</li> <li>• Change the engine oil filter.</li> </ul>
After the first 100 hours	<ul style="list-style-type: none"> <li>• Check the wheel hub slotted nut.</li> <li>• Change gear box oil.</li> </ul>
Before each use or daily	<ul style="list-style-type: none"> <li>• Check the safety system.</li> <li>• Check the engine oil.</li> <li>• Check the engine cooling system level.</li> <li>• Clean the engine oil cooler.</li> <li>• Check the mower blades.</li> <li>• Clean the mower deck.</li> </ul>
Every 25 hours	<ul style="list-style-type: none"> <li>• Grease the mower deck and spindles.</li> <li>• Grease the mower belt idler arm.</li> <li>• Grease the pump belt idler arm.</li> <li>• Grease the PTO drive belt idler arm.</li> <li>• Grease the brake lever.</li> <li>• Check the hydraulic fluid level.</li> </ul>
Every 40 hours	<ul style="list-style-type: none"> <li>• Drain the water separator.</li> </ul>
Every 50 hours	<ul style="list-style-type: none"> <li>• Check the tire pressure. or monthly, whichever occurs first.</li> <li>• Check the PTO drive belt.</li> <li>• Check the pump drive belt.</li> <li>• Check the alternator belt.</li> </ul>
Every 100 hours	<ul style="list-style-type: none"> <li>• Change the engine oil.</li> <li>• Check the gear box oil level.</li> <li>• Check the engine cooling system hoses.</li> <li>• Inspect the belts for cracks and wear.</li> <li>• Check the hydraulic hoses.</li> </ul>
Every 150 hours	<ul style="list-style-type: none"> <li>• Lubricate the machine with light oil (Refer to Lubrication).</li> </ul>
Every 200 hours	<ul style="list-style-type: none"> <li>• Change the engine oil filter.</li> <li>• Grease the brake pivot.</li> </ul>
Every 250 hours	<ul style="list-style-type: none"> <li>• Check and/or replace the air filter (more often in dirty or dusty conditions).</li> <li>• Change the hydraulic filter and hydraulic oil when using Mobil® 1 oil.</li> </ul>
Every 500 hours	<ul style="list-style-type: none"> <li>• Check the wheel hub slotted nut.</li> <li>• Adjust the caster pivot bearing.</li> <li>• Adjust the electric clutch.</li> <li>• Change the hydraulic filter and hydraulic oil when using Toro® HYPR-OIL™ 500 hydraulic oil.</li> </ul>
Yearly	<ul style="list-style-type: none"> <li>• Grease the front caster pivots (more often in dirty or dusty conditions).</li> <li>• Lubricate the caster wheel hubs.</li> <li>• Change the gear box oil.</li> <li>• Change the engine coolant.</li> </ul>

**Important:** Refer to your *Engine Operator's Manual* for additional maintenance procedures.

## ⚠ CAUTION

If you leave the key in the ignition switch, someone could accidentally start the engine and seriously injure you or other bystanders.

Remove the key from the ignition and disconnect the wire from the spark plug(s) before you do any maintenance. Set the wire aside so that it does not accidentally contact the spark plug.

# Lubrication

## Greasing and Lubrication

Lubricate the machine when shown on the Check Service Reference Aid decal (Figure 36). Grease more frequently when operating conditions are extremely dusty or sandy.

Grease Type: General-purpose grease.

### How to Grease

1. Disengage the PTO, move the motion control levers to the neutral locked position and set the parking brake.
2. Stop the engine, remove the key, and wait for all moving parts to stop before leaving the operating position.
3. Clean the grease fittings with a rag. Make sure to scrape any paint off the front of the fitting(s).
4. Connect a grease gun to the fitting. Pump grease into the fittings until grease begins to ooze out of the bearings.
5. Wipe up any excess grease.

## Greasing the Front Caster Pivots

**Service Interval:** Yearly

Lubricate the front caster pivots once a year.

1. Remove the dust cap and adjust the caster pivots. Keep the dust cap off until greasing is done. Refer to Adjusting the Caster Pivot Bearing (page 43).  
Remove the hex plug. Thread a grease fitting into the hole.
2. Pump grease into the fitting until it oozes out around the top bearing.
3. Remove the grease fitting in the hole. Install the hex plug and cap.

## Where to Add Grease

Lubricate the grease fittings as shown on the Check Service Reference Aid decal (Figure 36).

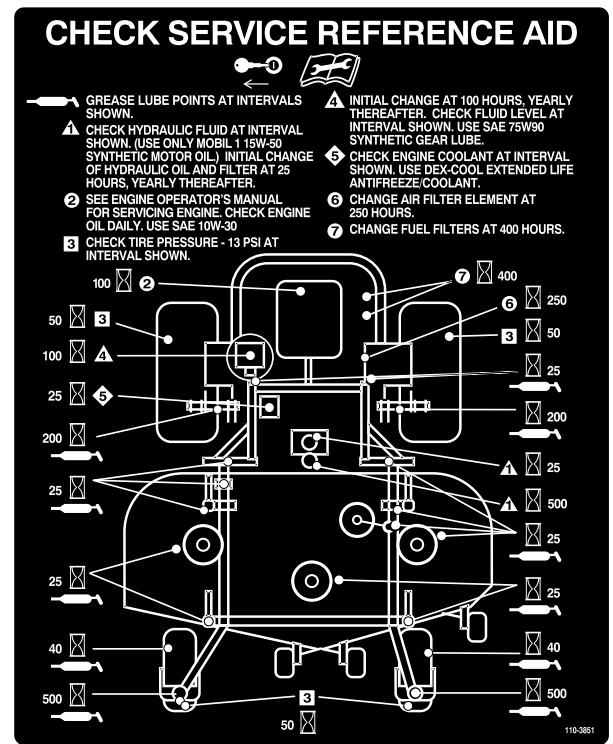

Figure 36

## Where to Add Light Oil or Spray Lubrication

**Service Interval:** Every 150 hours

Lubricate the machine in the following areas with spray type lubricant or light oil.

- Seat switch actuator.
- Brake handle pivot.
- Brake rod bushings.
- Motion control bronze bushings.



# Greasing the Mower Deck and Belt Idlers

**Service Interval:** Every 25 hours—Grease the mower deck and spindles.

Every 25 hours—Grease the mower belt idler arm.

Every 25 hours—Grease the pump belt idler arm.

Every 25 hours—Grease the PTO drive belt idler arm.

Grease with No. 2 general purpose lithium base or molybdenum base grease.

**Important:** Make sure cutting unit spindles are full of grease weekly.

1. Disengage the PTO, move the motion control levers to the neutral locked position, and set the parking brake.
2. Stop the engine, remove the key, and wait for all moving parts to stop before leaving the operating position.
3. Remove the belt covers.
4. Grease the three spindle bearings until grease comes out the lower seals (Figure 37).
5. Grease the idler arm on the mower deck (Figure 37).
6. Grease the fittings on the push arms (Figure 37).

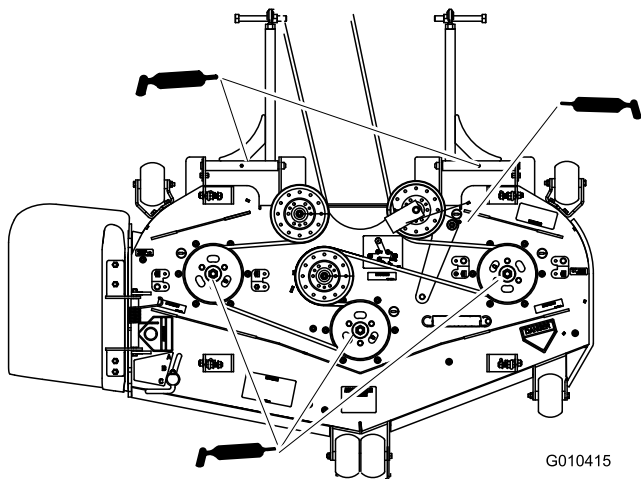

**Figure 37**

7. Grease the PTO drive belt idler arm (Figure 38).
8. Grease the pump belt idler arm (Figure 38).

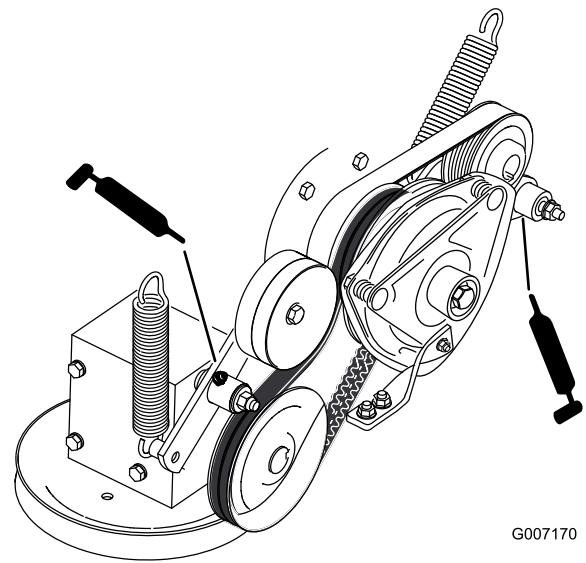
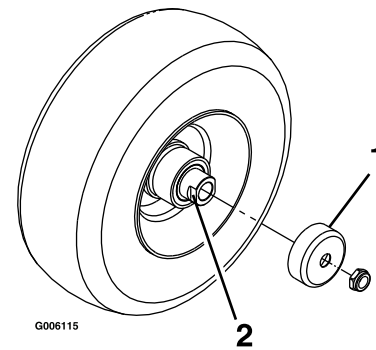

**Figure 38**

# Lubricate the Caster Wheel Hubs

**Service Interval:** Yearly

1. Stop the engine, wait for all moving parts to stop, and remove the key. Engage the parking brake.



**Figure 39**

1. Seal guard
2. Spacer nut with wrench flats

2. Remove the caster wheel from the caster forks.
3. Remove the seal guards from the wheel hub.
4. Remove 1 of the spacer nuts from the axle assembly in the caster wheel. Note that thread locking adhesive has been applied to lock the spacer nuts to the axle. Remove the axle (with the other spacer nut still assembled to it) from the wheel assembly.
5. Pry out the seals, and inspect the bearings for wear or damage and replace if necessary.
6. Pack the bearings with a general-purpose grease.
7. Insert 1 bearing and 1 new seal into the wheel.

**Note:** The seals must be replaced.

# Engine Maintenance

## Servicing the Air Cleaner

**Note:** Check the filters more frequently if operating conditions are extremely dusty or sandy.

### Removing the Air Filter

**Service Interval:** Every 250 hours

1. Disengage the PTO, move the motion control levers to the neutral locked position and set the parking brake.
2. Stop the engine, remove the key, and wait for all moving parts to stop before leaving the operating position.
3. Release the latches on the air cleaner and pull the air cleaner cover off of the air cleaner body (Figure 40).
4. Clean the inside of the air cleaner cover with compressed air.
5. Gently slide the filter out of the air cleaner body (Figure 40). Avoid knocking the filter into the side of the body.
6. Inspect the filter for damage by looking into the filter while shining a bright light on the outside of the filter. Holes in the filter will appear as bright spots. If the filter is damaged discard it.

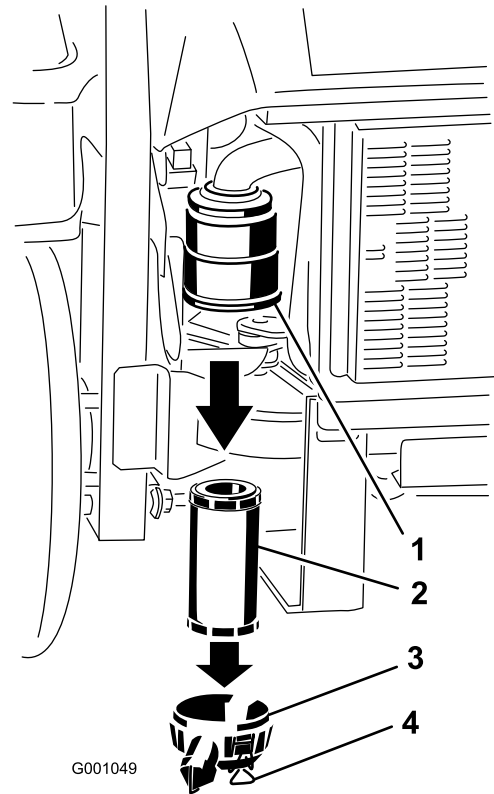

**Figure 40**

- |                    |                      |
|--------------------|----------------------|
| 1. Air filter body | 3. Air cleaner cover |
| 2. Air filter      | 4. Latches           |

8. If the axle assembly has had both spacer nuts removed (or broken loose), apply a thread locking adhesive to 1 spacer nut and thread it onto the axle with the wrench flats facing outward. Do not thread the spacer nut all of the way onto the end of the axle. Leave approximately 3 mm (1/8 inch) from the outer surface of the spacer nut to the end of the axle inside the nut.
9. Insert the assembled nut and axle into the wheel on the side of the wheel with the new seal and bearing.
10. With the open end of the wheel facing up, fill the area inside the wheel around the axle full of general-purpose grease.
11. Insert the second bearing and new seal into the wheel.
12. Apply a thread locking adhesive to the second spacer nut and thread it onto the axle with the wrench flats facing outward.
13. Torque the nut to 8-9 N-m (75-80 in-lb), loosen, then re-torque to 2-3 N-m (20-25 in-lb). Make sure that the axle does not extend beyond either nut.
14. Install the seal guards over the wheel hub and insert the wheel into the caster fork. Install the caster bolt and tighten the nut fully.

**Important:** To prevent seal and bearing damage, check the bearing adjustment often. Spin the caster tire. The tire should not spin freely (more than 1 or 2 revolutions) or have any side play. If the wheel spins freely, adjust the torque on the spacer nut until there is a slight amount of drag. Apply thread locking adhesive.

## Installing the Air Filter

1. If installing a new filter, check the filter for shipping damage. Do not use a damaged filter.
2. Carefully slide the filter into the filter body (Figure 41). Ensure that it is fully seated by pushing on the outer rim of the filter while installing it.

**Important:** Do not press on the soft inside area of the filter.

3. Install the air cleaner cover and secure the latches (Figure 41).

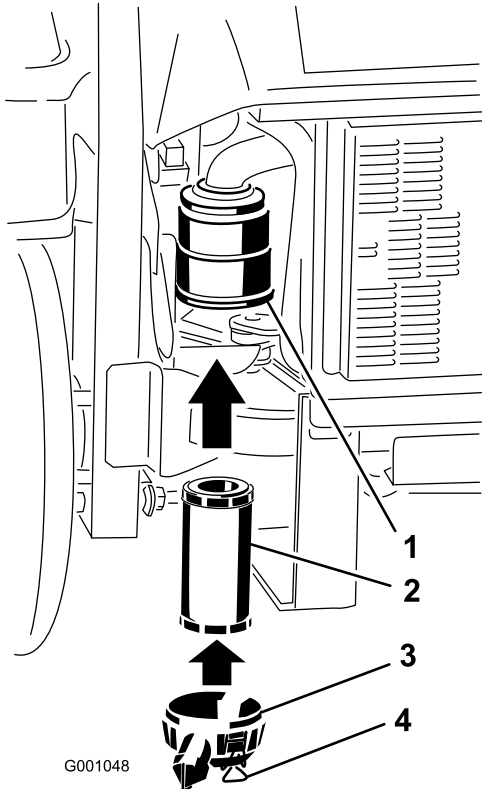

Figure 41

- |                    |                      |
|--------------------|----------------------|
| 1. Air filter body | 3. Air cleaner cover |
| 2. Air filter      | 4. Latches           |

## Servicing the Engine Oil

Oil Type: High-quality detergent oil classified API Service CD or higher for diesel engines. Do not use special additives with recommended oils.

Crankcase Capacity: 3.9 quarts (3.7 liters)

Viscosity: See the table below:

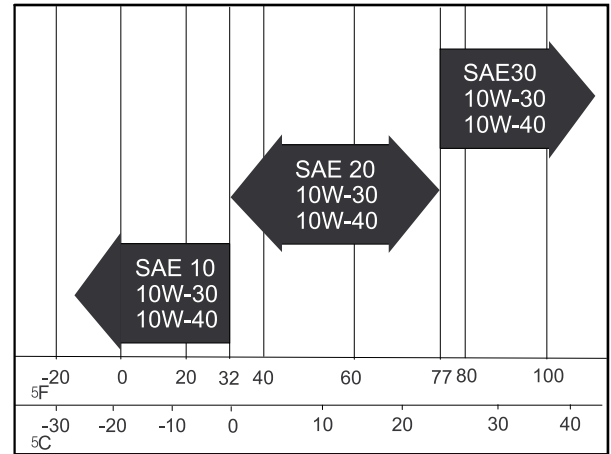

G001061

Figure 42

## Checking the Engine Oil Level

**Service Interval:** Before each use or daily

**Note:** Check the oil when the engine is cold.

1. Disengage the PTO, move the motion control levers to the neutral locked position and set the parking brake.
2. Stop the engine, remove the key, and wait for all moving parts to stop before leaving the operating position.
3. Clean around the oil dipstick (Figure 43) so dirt cannot fall into the filler hole and damage the engine.
4. Pull the oil dipstick out and wipe the metal end clean (Figure 43).
5. Slide the oil dipstick fully into the filler tube. Pull the dipstick out and look at the metal end (Figure 43). If the oil level is low, slowly pour only enough oil into the fill hole to raise the level to the full mark.

**Important:** Do not overfill the crankcase with oil because this may cause engine damage. Do not run the engine with oil below the low mark because the engine may be damaged as a result.

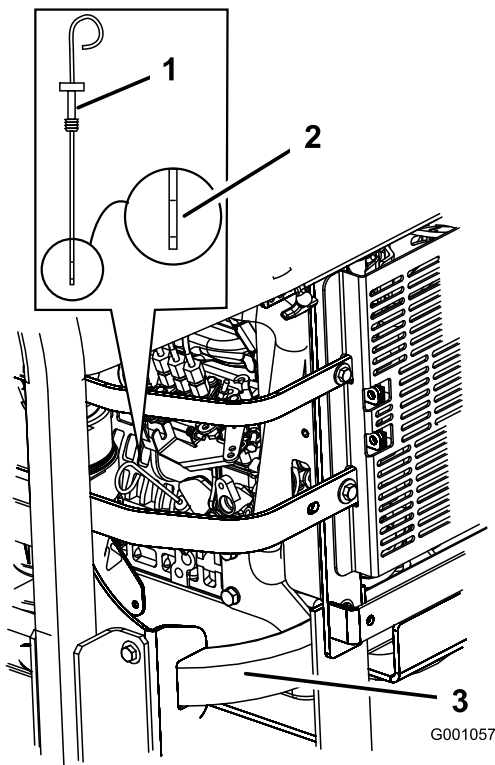

**Figure 43**

1. Oil dipstick
2. Metal end
3. Rear left side of machine

## Changing the Engine Oil

**Service Interval:** After the first 50 hours

Every 100 hours

1. Start the engine and let it run for 5 minutes. This warms the oil so it drains better.
2. Park the machine on a level surface.
3. Disengage the PTO, move the motion control levers to the neutral locked position and set the parking brake.
4. Stop the engine, remove the key, and wait for all moving parts to stop before leaving the operating position.
5. Place a pan below the oil drain. Remove the drain plug and let the oil drain completely (Figure 44).
6. Remove the oil filler cap from the top of the engine (Figure 46). This will help the oil to drain.
7. Install the drain plug and tighten it to 25-1/2 ft-lb (35 N-m).

**Note:** Dispose of the used oil at a recycling center.

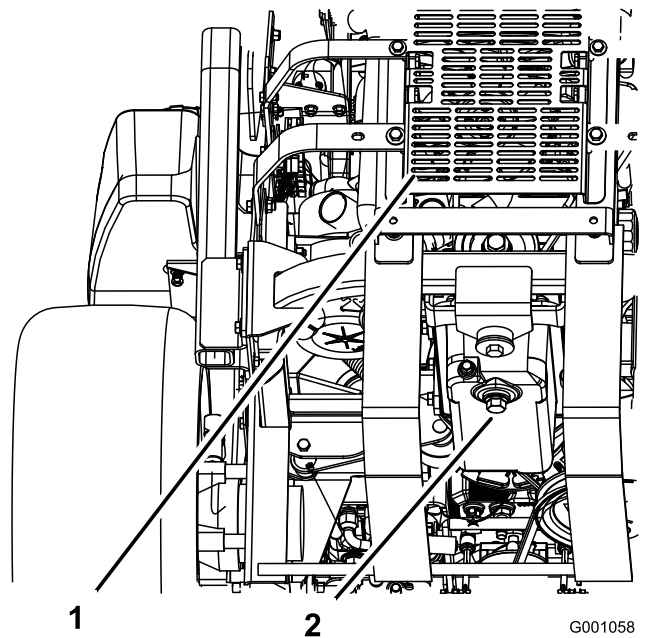

**Figure 44**

1. Back of machine
2. Drain plug

## Adding Engine Oil

**Important:** The fasteners for the front engine panel are designed to remain on the machine after cover removal. Loosen all of the fasteners a few turns so that the panel is loose but still attached, then go back and loosen them until the panel comes free. This will prevent you from accidentally stripping the bolts free of the retainers.

1. Tilt the seat forward, loosen the bolts, and remove the front engine panel (Figure 45).

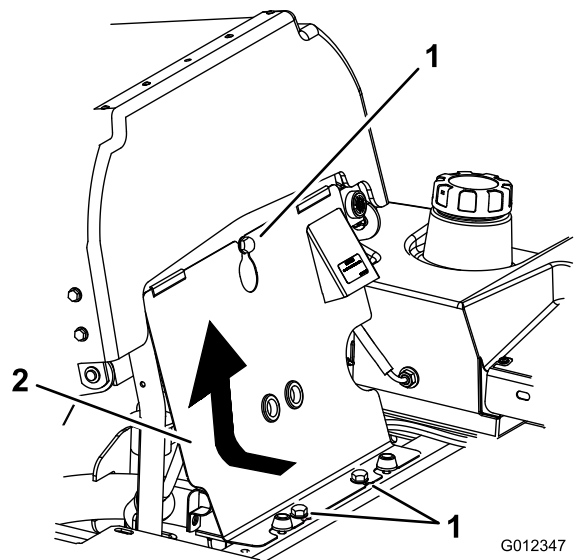

**Figure 45**

1. Bolt
2. Front engine panel

- Remove the oil filler cap and the dipstick (Figure 46).

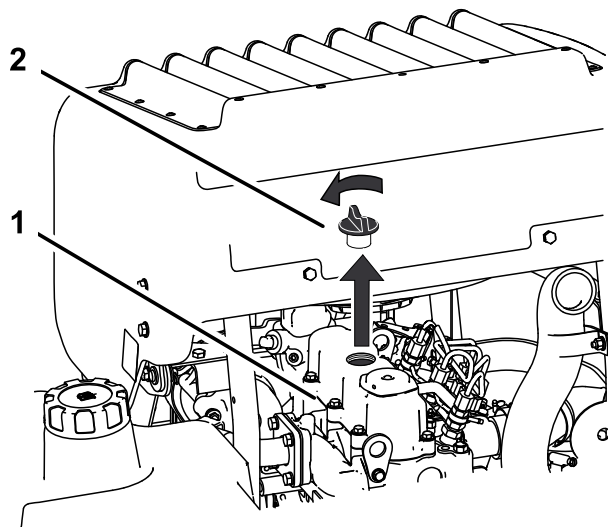

**Figure 46**

- Engine
- Oil fill cap

- To add oil to the engine, locate and use a hose and funnel for adding oil (Figure 47).
- Add oil slowly, checking the level with the dipstick frequently until the level reaches the upper hole on the dipstick. For the correct oil type and viscosity to use in different temperature conditions, refer to Servicing the Engine Oil (page 35).

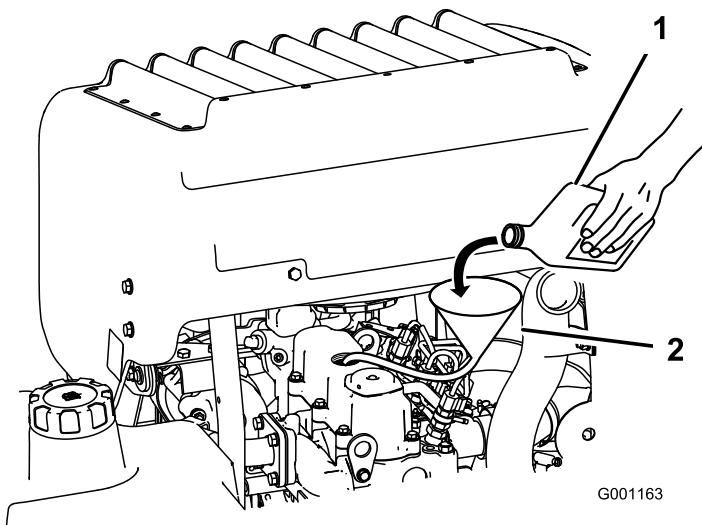

**Figure 47**

- Engine oil
- Funnel and hose

**Important:** Add the oil very slowly and do not block the opening of the filler hole (Figure 48). If you add oil too fast or block the hole, the oil could back up and foul the air intakes, causing engine damage.

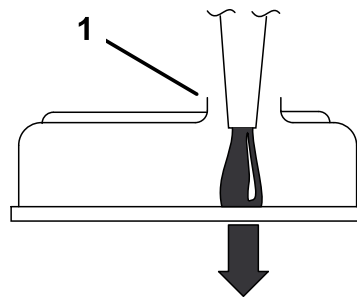

G000955

**Figure 48**

- Note the clearance left in the filler opening.
- Install the dipstick and the front engine panel.
- Start the engine and run it at idle for 5 minutes.
- Shut off the engine.
- Wait 3 minutes and check the oil level.
- Add oil, if required, to bring the level to the upper hole on the dipstick.
- Install the dipstick, filler cap, and the front engine panel.
- Check for leaks.

**Important:** Do not overfill the crankcase with oil because this may cause engine damage.

## Changing the Engine Oil Filter

**Service Interval:** After the first 50 hours

Every 200 hours

- Drain the oil from the engine; refer to Changing the Engine Oil (page 36).  
Place a drip pan beneath the oil drip tray to receive oil from the oil filter and oil passages in the engine.
- Turn the filter counterclockwise to remove it (Figure 49 and Figure 50).  
**Note:** Dispose of the oil filter properly. Recycle in accordance with local codes.
- Before installing the filter, lightly oil the gasket on the filter with fresh, clean oil. Screw the filter on by hand until the gasket contacts the oil filter adapter. Tighten 1/2 to 3/4 turn more.
- Add oil; refer to Adding Engine Oil (page 36).

# Fuel System Maintenance

## Servicing the Fuel Filter

### Draining the Water Separator

**Service Interval:** Every 40 hours

1. Position the machine on a level surface.
2. Disengage the PTO, move the motion control levers to the neutral locked position, and set the parking brake.
3. Stop the engine, remove the key, and wait for all moving parts to stop before leaving the operating position.
4. Locate the water separator at the back left of the machine.
5. Place a drain pan below the water separator.
6. Open the drain valve on the water separator approximately one turn to allow water and other contaminants to drain (Figure 51).
7. Close the drain valve when only diesel fuel comes out (Figure 51).

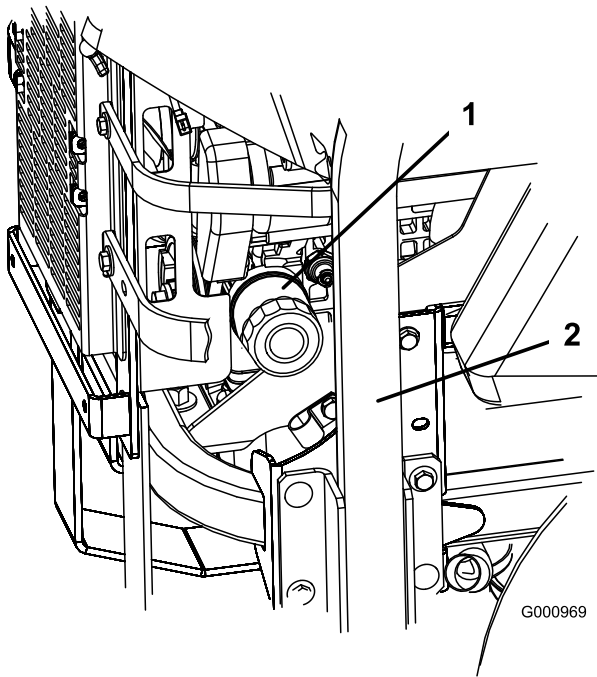

**Figure 49**

1. Oil filter
2. Right side of machine

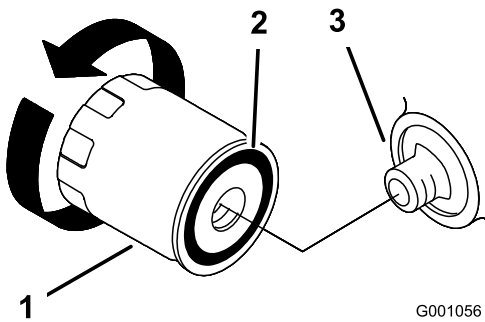

**Figure 50**

1. Oil filter
2. Gasket
3. Adapter

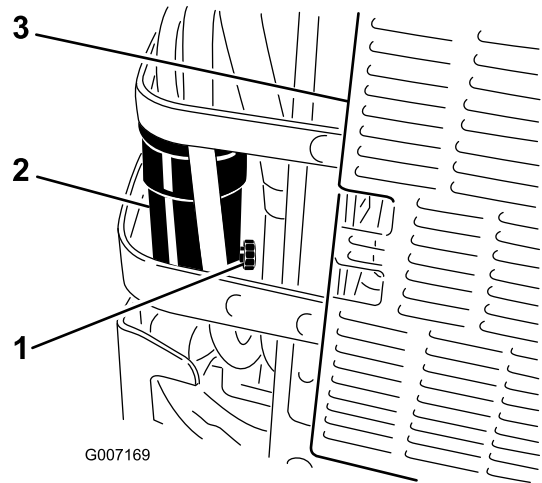

**Figure 51**

1. Drain valve
2. Water separator
3. Back of machine

## Changing the Fuel Filter

Never install a dirty fuel filter if it is removed from the fuel line.

1. Allow the machine to cool down.
2. Disengage the PTO, move the motion control levers to the neutral locked position, and set the parking brake.
3. Stop the engine, remove the key, and wait for all moving parts to stop before leaving the operating position.
4. Close the fuel shut-off valve(Figure 52).
5. Loosen the two hose clamps and disconnect the fuel lines from the fuel filter (Figure 52).
6. Install a new filter. Connect the fuel lines to the fuel filter and install the hose clamps (Figure 52).
7. Open the fuel shut-off valve.
8. Start the engine and check for leaks.

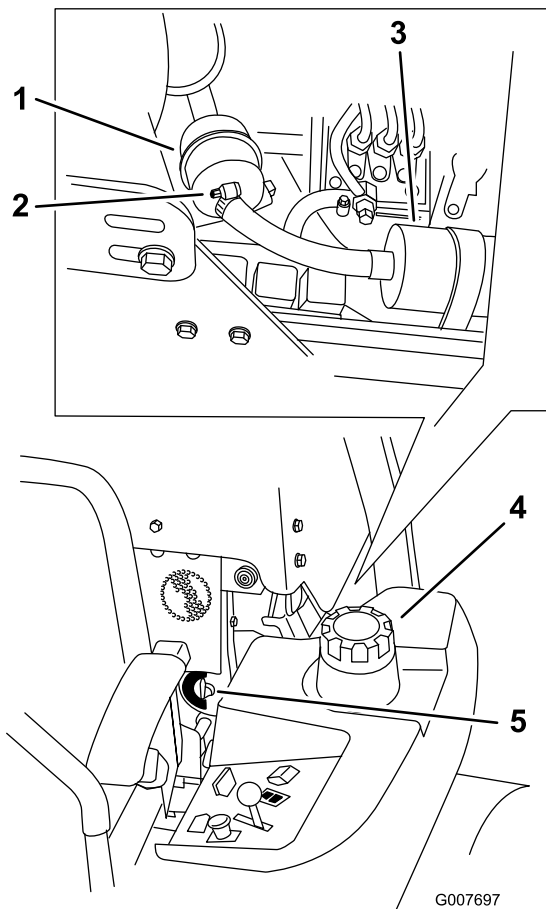

**Figure 52**

- |                |                         |
|----------------|-------------------------|
| 1. Fuel filter | 4. Left side of machine |
| 2. Hose clamp  | 5. Fuel shut-off valve  |
| 3. Fuel pump   |                         |

## Servicing the Fuel Tank

Do not attempt to drain the fuel tank because fuel line components require special tools to install them. Ensure that an Authorized Service Dealer drains the fuel tank and services any components of the fuel system.

# Electrical System Maintenance

## Servicing the Battery

### WARNING

#### CALIFORNIA Proposition 65 Warning

Battery posts, terminals, and related accessories contain lead and lead compounds, chemicals known to the State of California to cause cancer and reproductive harm. Wash hands after handling.

### ⚠ DANGER

Battery electrolyte contains sulfuric acid which is a deadly poison and causes severe burns.

Do not drink electrolyte and avoid contact with skin, eyes or clothing. Wear safety glasses to shield your eyes and rubber gloves to protect your hands.

## Removing the Battery

### ⚠ WARNING

Battery terminals or metal tools could short against metal machine components causing sparks. Sparks can cause the battery gasses to explode, resulting in personal injury.

- When removing or installing the battery, do not allow the battery terminals to touch any metal parts of the machine.
- Do not allow metal tools to short between the battery terminals and metal parts of the machine.

### ⚠ WARNING

Incorrect battery cable routing could damage the machine and cables causing sparks. Sparks can cause the battery gasses to explode, resulting in personal injury.

- Always Disconnect the negative (black) battery cable before disconnecting the positive (red) cable.
- Always Reconnect the positive (red) battery cable before reconnecting the negative (black) cable.

1. Disengage the PTO, move the motion control levers to the neutral locked position, and set the parking brake.
2. Stop the engine, remove the key, and wait for all moving parts to stop before leaving the operating position.
3. Unlatch the seat and tilt the seat up.
4. First disconnect the negative battery cable from the negative (-) battery terminal (Figure 53).
5. Slide the red terminal boot off the positive (red) battery terminal. Then remove the positive (red) battery cable (Figure 53).

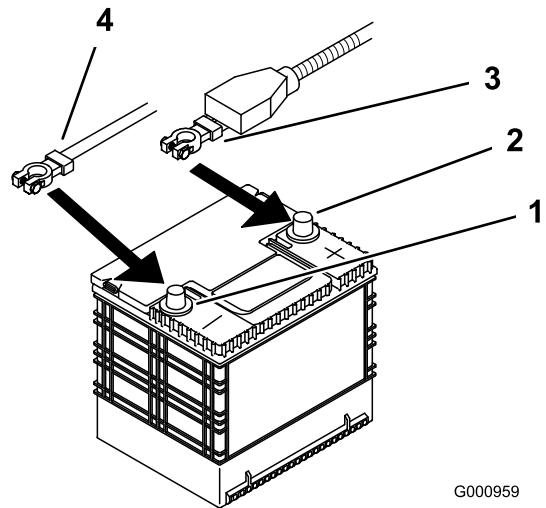

Figure 53

- |                          |                    |
|--------------------------|--------------------|
| 1. Negative battery post | 3. Red (+) cable   |
| 2. Positive battery post | 4. Black (-) cable |

6. Remove both wing nuts (1/4 inch) securing the battery clamp (Figure 54).
7. Remove the bolts holding the hydraulic tank in place (Figure 54).
8. Slide the hydraulic tank away from the battery.
9. Remove the battery.



## Charging the Battery

### ⚠ WARNING

Charging the battery produces gasses that can explode.

Never smoke near the battery and keep sparks and flames away from battery.

**Important:** Always keep the battery fully charged (1.265 specific gravity). This is especially important to prevent battery damage when the temperature is below 32°F (0°C).

1. Make sure that the filler caps are installed in the battery. Charge the battery for 10 to 15 minutes at 25 to 30 amps or 30 minutes at 10 amps.
2. When the battery is fully charged, unplug the charger from the electrical outlet, then disconnect the charger leads from the battery posts (Figure 55).
3. Install the battery in the machine and connect the battery cables, refer to Installing the Battery (page 41).

**Note:** Do not run the machine with the battery disconnected, electrical damage may occur.

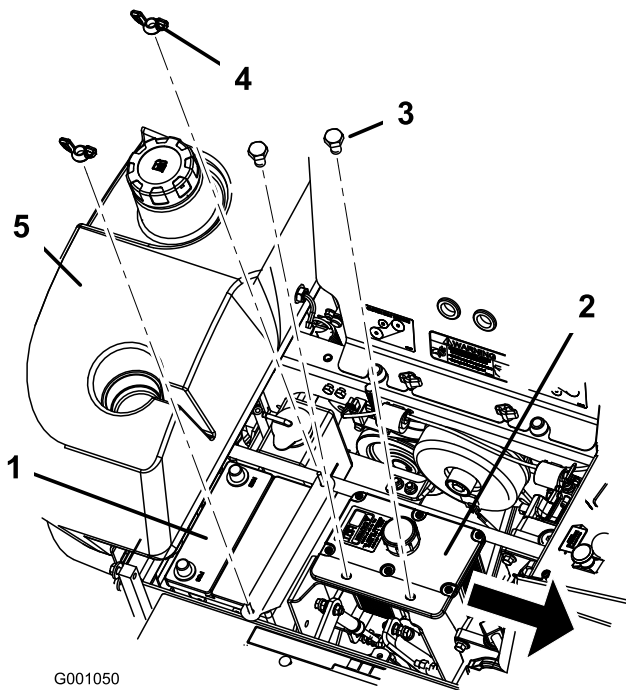

G001050

**Figure 54**

- |                   |                         |
|-------------------|-------------------------|
| 1. Battery        | 4. Wing nut             |
| 2. Hydraulic tank | 5. Right side fuel tank |
| 3. Bolts          |                         |

## Installing the Battery

1. Position the battery in the tray with the terminal posts opposite from the hydraulic tank (Figure 54).
2. First, install the positive (red) battery cable to positive (+) battery terminal.
3. Then install the negative battery cable and ground wire to the negative (-) battery terminal.
4. Secure the cables with 2 bolts (1/4 x 3/4 inch), 2 washers (1/4 inch), and 2 locknuts (1/4 inch) (Figure 53).
5. Slide the red terminal boot onto the positive (red) battery post.
6. Secure battery with J-bolts, hold down clamp, 2 washers (1/4 inch), and 2 wing nuts (1/4 inch) (Figure 54).

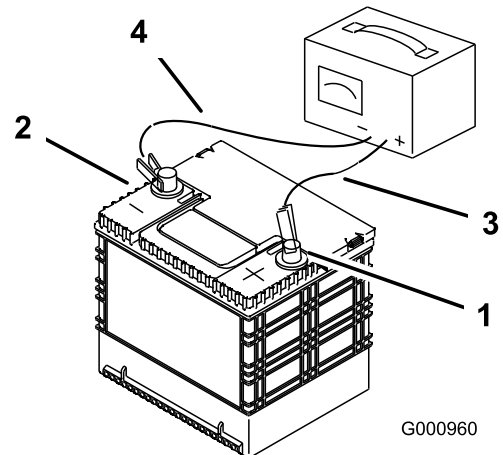

G000960

**Figure 55**

- |                          |                           |
|--------------------------|---------------------------|
| 1. Positive battery post | 3. Red (+) charger lead   |
| 2. Negative battery post | 4. Black (-) charger lead |

# Servicing the Fuses

The electrical system is protected by fuses. It requires no maintenance, however, if a fuse blows check component/circuit for malfunction or short.

1. Unlatch the engine hood and raise the engine hood to gain access to fuse holder (Figure 56).
2. To replace the fuses, pull out on the fuse to remove it.
3. Install a new fuse (Figure 56).

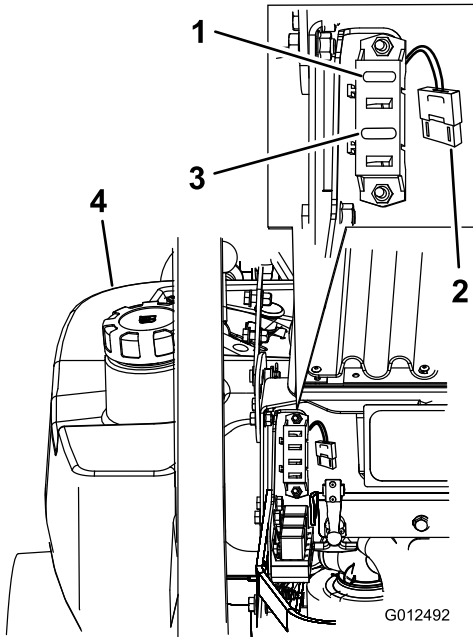

Figure 56

- |  |                        |
|--|------------------------|
| 1. Ignition-30 amp (F1)                            | 3. Clutch-10 amp (F3)  |
| 2. Radiator fan-50 amp<br>(large, heavy duty fuse) | 4. Left side fuel tank |

# Drive System Maintenance

## Adjusting the Tracking

The machine has a knob for adjusting the tracking located under the seat.

**Important:** Adjust the handle neutral and hydraulic pump neutral before adjusting the tracking. Refer to **Adjusting the Control Handle Neutral Position (page 51)** and **Setting the Hydraulic Pump Neutral Position (page 54)**.

1. Push both of the control levers forward in the same distance.
2. Check if the machine pulls to one side. If it does, stop the machine and set the parking brake.
3. Unlatch the seat and tilt the seat forward to access the tracking knob.

**Note:** Determine the left and right sides of the machine from the normal operating position.

4. To make the machine go right, turn the knob towards the right side of the machine. Refer to Figure 57.
5. To make the machine go left, turn the knob towards the left side of the machine. Refer to Figure 57.
6. Repeat the adjustment until the tracking is correct.

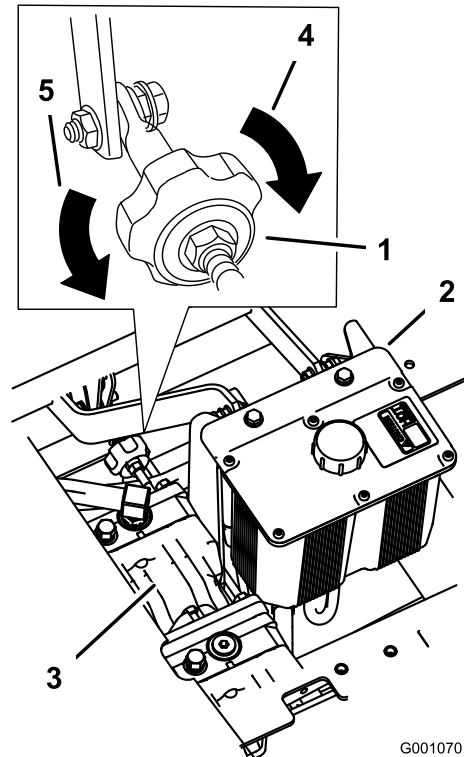

Figure 57

- |                    |                                  |
|--------------------|----------------------------------|
| 1. Tracking knob   | 4. Turn this way to track right. |
| 2. Hydraulic tank  | 5. Turn this way to track left.  |
| 3. Hydraulic pumps |                                  |

## Checking the Tire Pressure

**Service Interval:** Every 50 hours or monthly, whichever occurs first.

Check the pressure at the valve stem (Figure 58).

Maintain the air pressure in the rear tires at 90 kPa (13 psi). Uneven tire pressure can cause uneven cut. Check the tires when they are cold to get the most accurate pressure reading.

**Note:** The front tires are semi-pneumatic tires and do not require air pressure maintenance.

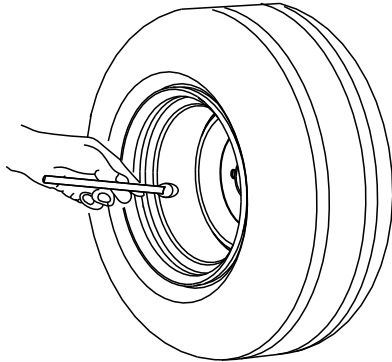

G001055

Figure 58

## Checking the Wheel Hub Slotted Nut

**Service Interval:** After the first 100 hours—Check the wheel hub slotted nut.

Every 500 hours—Check the wheel hub slotted nut.

Torque the slotted nut to 211-260 ft-lb (286-352 N-m).

**Note:** Do not use anti-seize on the wheel hub.

## Adjusting the Caster Pivot Bearing

**Service Interval:** Every 500 hours

1. Disengage the PTO, move the motion control levers to the neutral locked position, and set the parking brake.
2. Stop the engine, remove the key, and wait for all moving parts to stop before leaving the operating position.
3. Remove the dust cap from the caster and tighten the locknut (Figure 59).

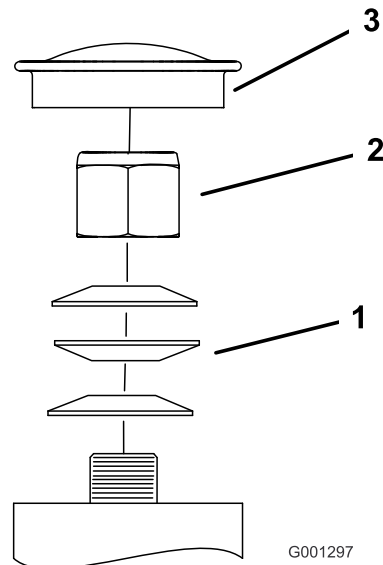

G001297

Figure 59

1. Spring washers
2. Locknut
3. Dust cap

4. Tighten the locknut until the spring washers are flat, then back off a 1/4 turn to properly set the pre-load on the bearings (Figure 59).

**Important:** Make sure that the spring washers are installed correctly as shown in Figure 59.

5. Install the dust cap (Figure 59).

# Servicing the Gear Box

## Checking the Gear Box Oil Level

**Service Interval:** Every 100 hours

Use SAE 75W-90 Synthetic Gear Lube.

1. Park the machine on a level surface.
2. Disengage the PTO, move the motion control levers to the neutral locked position, and set the parking brake.
3. Stop the engine, remove the key, and wait for all moving parts to stop before leaving the operating position.
4. Remove the side or rear plug on the gear box. (Figure 60).
5. The oil should be up to the opening of the gear box.
6. Add oil if needed to bring it to the correct level.

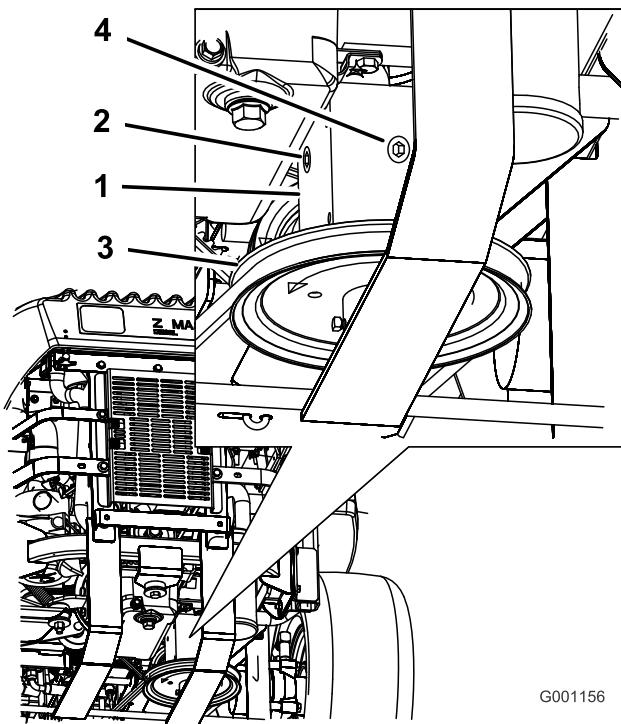

**Figure 60**

- |              |              |
|--------------|--------------|
| 1. Gear box  | 3. Rear plug |
| 2. Side plug | 4. Pulley    |

# Adjusting the Electric Clutch

**Service Interval:** Every 500 hours

The clutch is adjustable to ensure proper engagement and proper braking.

1. Disengage the PTO, move the motion control levers to the neutral locked position, and set the parking brake.
2. Stop the engine, remove the key, and wait for all moving parts to stop before leaving the operating position.
3. Tilt the seat forward, loosen the bolts, and remove the front engine panel.
4. Pull up on the spring loaded idler pulley for the PTO drive belt and remove the belt from the clutch pulley (Figure 61).

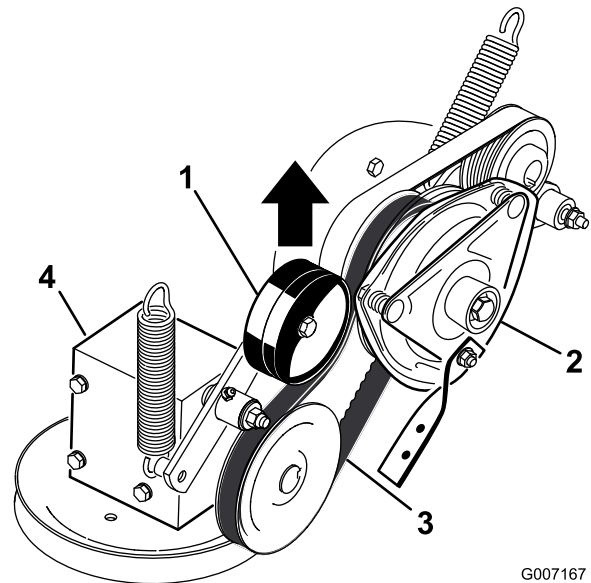

**Figure 61**

- |                               |                   |
|-------------------------------|-------------------|
| 1. Spring loaded idler pulley | 3. PTO drive belt |
| 2. Clutch                     | 4. Gear box       |

5. Unplug the electric connection for the clutch (Figure 62).
6. Remove the bolts holding the rubber clutch strap to the mower frame (Figure 62).
7. Remove the center bolt holding the clutch to the engine shaft and remove the clutch and key (Figure 62).

## Changing the Gear Box Oil

**Service Interval:** After the first 100 hours

Yearly

Contact an Authorized Service Dealer to change the gear box oil.

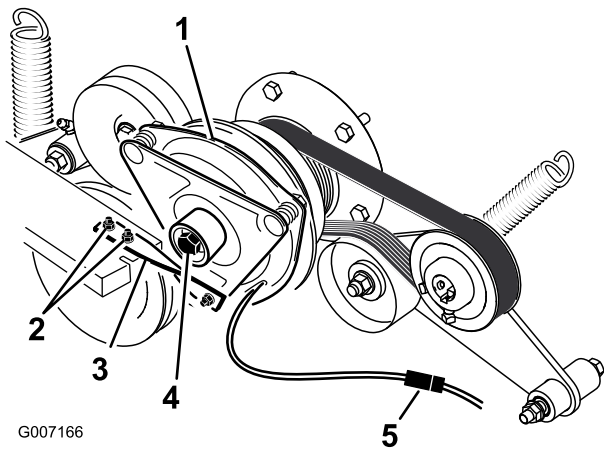

**Figure 62**

- |  |                          |
|--|--------------------------|
| 1. Clutch                                  | 4. Clutch center bolt    |
| 2. Bolts (2) and nuts for the clutch strap | 5. Electrical connection |
| 3. Rubber clutch strap                     |                          |

- 
8. Insert a 0.381–0.533 mm (0.015–0.021 inch) feeler gauge through one inspection slot in the side of the assembly. Make sure that it is between the armature and the rotor friction surfaces (Figure 63).
  9. Tighten the lock nuts until there is slight binding on the feeler gauge but it can be moved easily within the air gap (Figure 63).
  10. Repeat this for the remaining slots.
  11. Check each slot again and make slight adjustments until the feeler gauge between the rotor and armature with very slight contact between them.

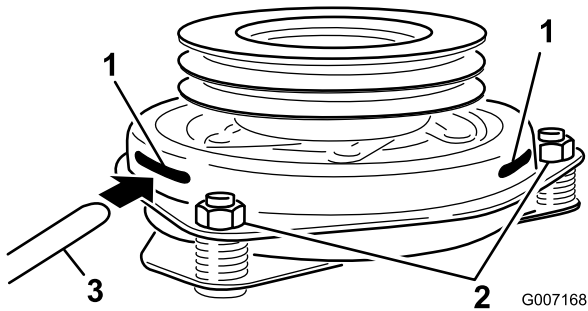

**Figure 63**

- |                  |                 |
|------------------|-----------------|
| 1. Slot          | 3. Feeler gauge |
| 2. Adjusting nut |                 |

- 
12. Install the clutch to the engine shaft with the key.
  13. Apply thread locking adhesive to the center bolt.
  14. While holding the crank shaft at the back of the machine, install the center bolt and torque it to 50 ft-lbs (68 N-m) (Figure 62).
  15. Install the rubber clutch strap to the mower frame with the two previously removed bolts and nuts (Figure 62).
  16. Pull up on the spring loaded idler for the PTO drive belt and install it onto the clutch pulley (Figure 61).

17. Plug in the electric connection for the clutch (Figure 62).
18. Install the front engine panel.
19. Lower the seat.

# Cooling System Maintenance

## Servicing the Cooling System

### **⚠ DANGER**

Discharge of hot pressurized coolant or touching a hot radiator and surrounding parts can cause severe burns.

- Do not remove the radiator cap when the engine is hot. Always allow the engine to cool at least 15 minutes or until the radiator cap is cool enough to touch without burning your hand before removing the radiator cap.
- Do not touch the radiator and surrounding parts that are hot.

### **⚠ WARNING**

A rotating shaft and fan can cause personal injury.

- Do not operate the machine without the covers in place.
- Keep fingers, hands, and clothing clear of the rotating fan and drive shaft.
- Shut off the engine and remove the ignition key before performing maintenance.

### **⚠ CAUTION**

Swallowing engine coolant can cause poisoning.

- Do not swallow engine coolant.
- Keep out of reach from children and pets.

## Checking the Engine Coolant Level

**Service Interval:** Before each use or daily

After the first 8 hours

Every 100 hours

Fluid Type: 50/50 mix of extended life antifreeze and water

Cooling System Capacity: 156 ounces (4.6 l)

**Note:** Do not open the radiator cap. Doing this may induce air into the cooling system.

1. Position the machine on a level surface, stop the engine, and set the parking brake.
2. Unlatch the seat and tilt the seat up.

3. With the engine cool, check the overflow bottle level. The fluid needs to be up to the bump on the outside of the overflow bottle (Figure 64).
4. If the coolant level is low, add a 50/50 mix of extended life antifreeze and water to the overflow bottle (Figure 64).
5. Add the 50/50 coolant mix to the overflow bottle and fill it to the indicator line on the bottle (Figure 64).

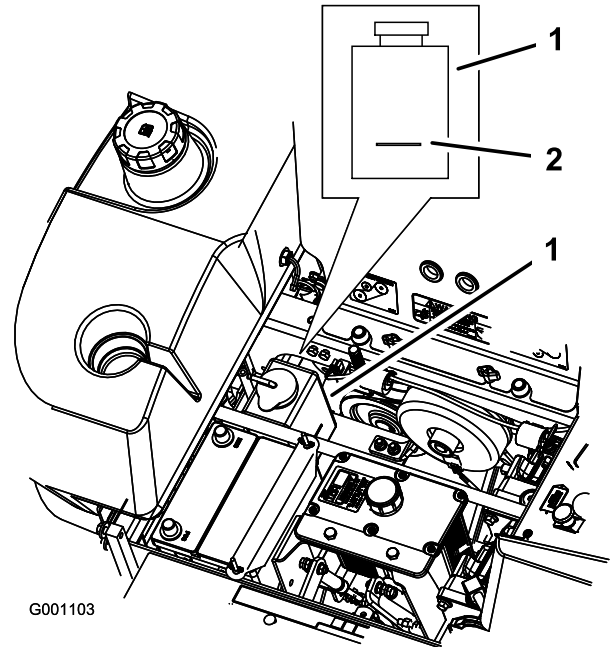

**Figure 64**

1. Antifreeze overflow bottle
2. Indicator line on side of overflow bottle

## Cleaning the Engine Oil Cooler and Radiator Screen

**Service Interval:** Before each use or daily

Before each use, check and clean the radiator screen and oil cooler. Remove any build-up of grass, dirt or other debris from the oil cooler and radiator screen with compressed air (Figure 65).

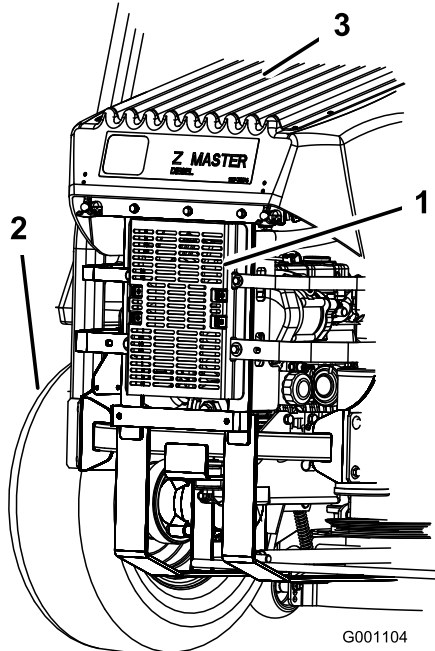

**Figure 65**

1. Hydraulic oil cooler
2. Left rear tire
3. Radiator screen

## Changing the Engine Coolant

**Service Interval:** Yearly

Have an Authorized Service Dealer change the engine coolant every year.

## Brake Maintenance

### Adjusting the Parking Brake

**Service Interval:** Every 25 hours

Every 200 hours

1. Engage the parking brake.
2. Measure the length of the spring. Measurement should be 64 mm (2-1/2 inch) between the washers (Figure 66).
3. If adjustment is necessary, release the parking brake, loosen the jam nut below the spring, and adjust the nut directly below the spring (Figure 66). Turn the nut until the correct measurement is obtained. Turn the nut clockwise to shorten the spring length and turn it counter-clockwise to lengthen the spring.
4. Tighten the nuts together.
5. Engage the parking brake. Check the measurement of the spring again.
6. If adjustment is necessary, repeat the procedures above.
7. Repeat on the opposite side of machine.

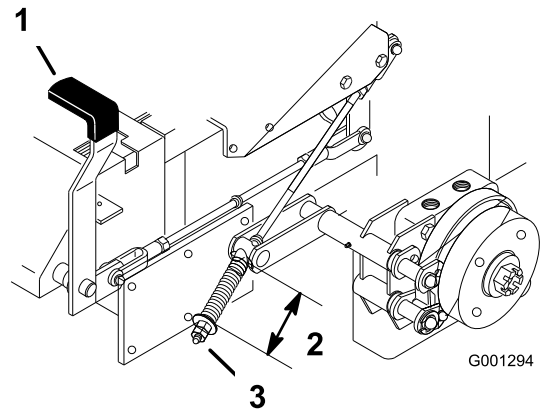

**Figure 66**

1. Brake lever in engaged
2. Spring 2-1/2 inch (64 mm)
3. Adjusting nut and jam nut position

# Belt Maintenance

## Inspecting the Belts

**Service Interval:** Every 100 hours

Check belts for cracks, frayed edges, burn marks, or any other damage. Replace damaged belts.

## Replacing the Mower Belt

Squealing when the belt is rotating, blades slipping when cutting grass, frayed belt edges, burn marks, and cracks are signs of a worn mower belt. Replace the mower belt if any of these conditions are evident.

**Important:** The fasteners on the mower deck covers of this machine are designed to remain on the cover after removal. Loosen all of the fasteners on each cover a few turns so that the cover is loose but still attached, then go back and loosen them until the cover comes free. This will prevent you from accidentally stripping the bolts free of the retainers.

1. Disengage the PTO, move the motion control levers to the neutral locked position, and set the parking brake.
2. Stop the engine, remove the key, and wait for all moving parts to stop before leaving the operating position.
3. Remove the belt covers and the bolts attached to them (Figure 67).
4. Remove the spring and belt guide from the idler arm.
5. Remove the existing belt if needed.
6. Install the new belt around the mower pulleys and the gearbox pulley under the engine (Figure 68).
7. Install the belt guide on the spring loaded idler at a 45 degree angle as shown in Figure 68. Torque the bolt to 27 to 33 ft-lb (37 to 45 N-m).
8. Install the idler spring to the two posts (Figure 68).
9. Install the belt covers by sliding the cover into the tab, tighten the bolts, and close the latches (Figure 67).

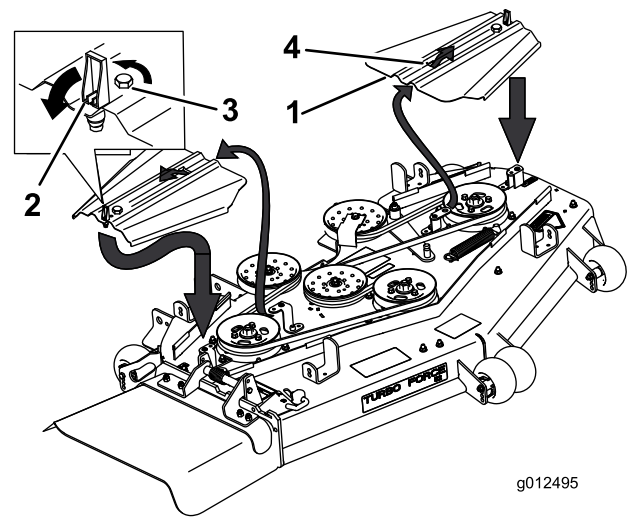

**Figure 67**

- |               |                            |
|---------------|----------------------------|
| 1. Belt cover | 3. Bolt                    |
| 2. Latch      | 4. Insert tab into the tab |

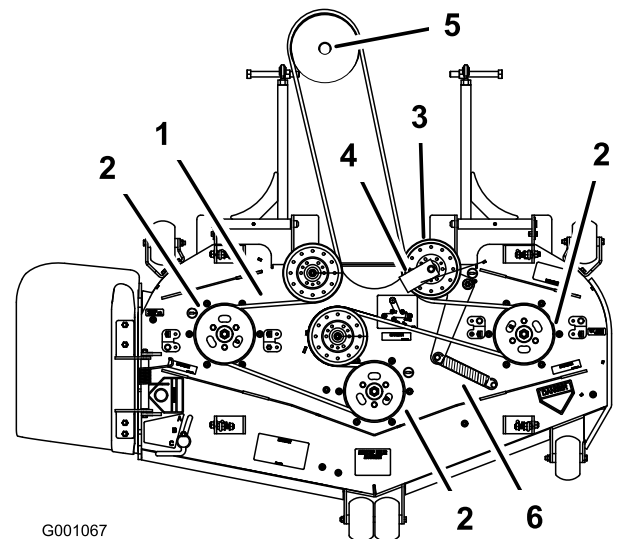

**Figure 68**

- |                         |                   |
|-------------------------|-------------------|
| 1. Mower belt           | 4. Belt guide     |
| 2. Mower spindle pulley | 5. Gearbox pulley |
| 3. Mower idler pulley   | 6. Spring         |



# Replacing the PTO Drive Belt

**Service Interval:** Every 50 hours—Check the PTO drive belt.

**Important:** The fasteners for the front engine panel are designed to remain on the machine after cover removal. Loosen all of the fasteners a few turns so that the panel is loose but still attached, then go back and loosen them until the panel comes free. This will prevent you from accidentally stripping the bolts free of the retainers.

1. Disengage the PTO, move the motion control levers to the neutral locked position, and set the parking brake.
2. Stop the engine, remove the key, and wait for all moving parts to stop before leaving the operating position.
3. Tilt the seat forward, loosen the bolts and remove the front engine panel (Figure 69).

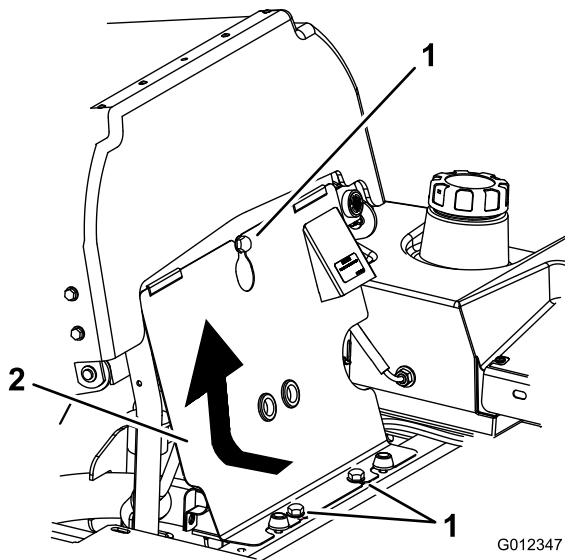

**Figure 69**

1. Bolts
2. Front engine panel

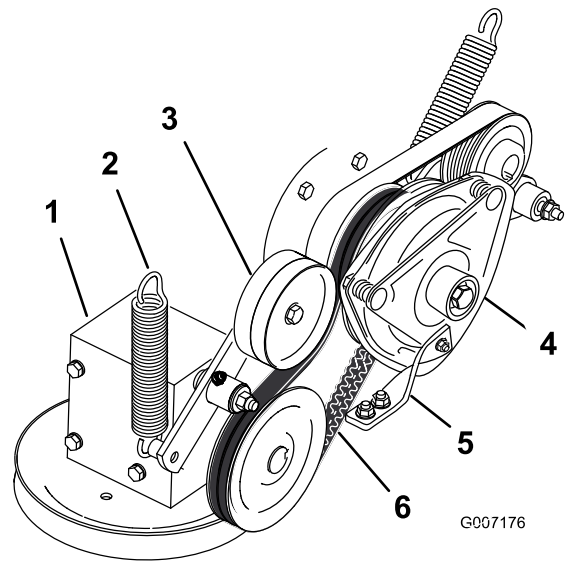

**Figure 70**

1. Gear box
2. Spring
3. Spring loaded idler pulley
4. Clutch
5. Rubber clutch stop
6. PTO Drive belt

4. Remove the spring from the idler arm (Figure 70).
5. Remove the clutch stop bracket.
6. Remove the old PTO drive belt.
7. Install the PTO drive belt around the clutch pulley and the gearbox pulley (Figure 70).
8. Install the rubber clutch stop.
9. Install the spring to the idler arm (Figure 70).
10. Install the front engine panel.

# Replacing the Pump Drive Belt

**Service Interval:** Every 50 hours—Check the pump drive belt.

**Note:** Remove the PTO drive belt first if the pump drive belt needs to be replaced.

1. Tilt the seat forward, loosen the bolts and remove the front engine panel.
2. Remove the PTO drive belt.
3. Remove the spring from the idler arm (Figure 71).
4. Install the new belt around the engine and hydro pump pulley (Figure 71).
5. Install the PTO drive belt.
6. Install the spring to the idler arm (Figure 71).
7. Install the front engine panel.

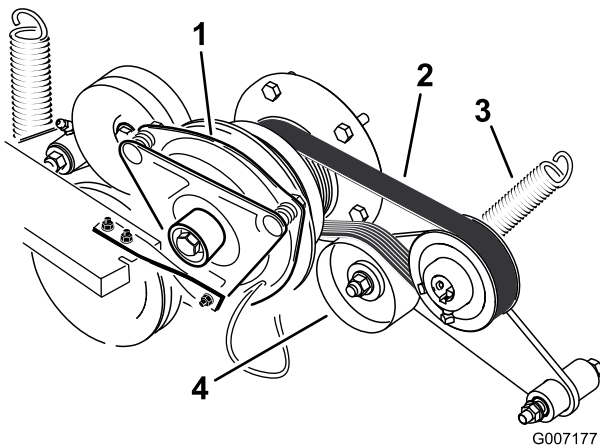

**Figure 71**

- |                    |                               |
|--------------------|-------------------------------|
| 1. Clutch          | 3. Spring                     |
| 2. Pump drive belt | 4. Spring loaded idler pulley |

# Replacing and Tensioning the Alternator Belt

## Replacing the Alternator Belt

**Service Interval:** Every 50 hours—Check the alternator belt.

If the alternator belt needs to be replaced, take your machine to an Authorized Service Dealer.

## Tensioning the Alternator Belt

1. Place a handle between the alternator and cylinder block.
2. Adjust the alternator to the outside until there is 7 to 9 mm (1/4 to 11/32 inch) deflection in the belt between the engine and the alternator pulleys with 10 kgf (22.1 lbs of force) (Figure 72).
3. Tighten the alternator bolts.
4. Check the deflection in the belt again and adjust the belt if needed.
5. If the deflection is correct, tighten the bottom and upper bolt (Figure 72).

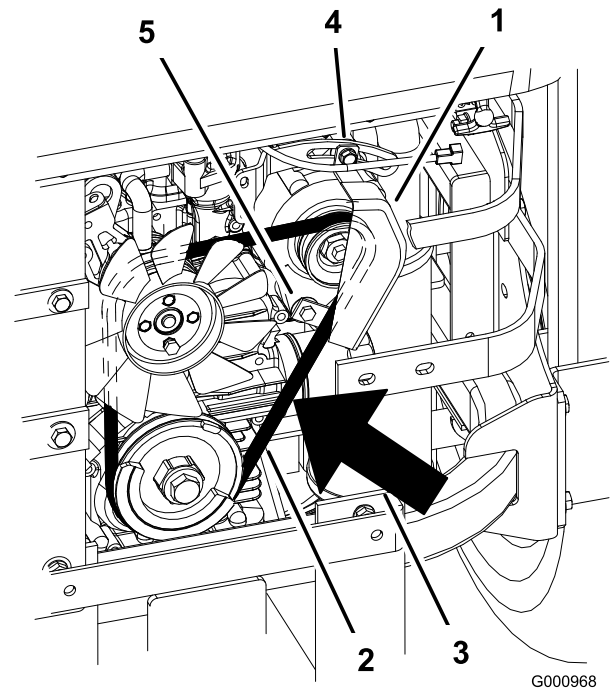

**Figure 72**

- |  |                |
|--|----------------|
| 1. Alternator  | 4. Top bolt    |
| 2. Alternator belt   | 5. Bottom bolt |
| 3. Deflection, 7 to 9 mm (1/4 to 11/32 inch) with 10 kgf (22.1 lbs of force) |                |

# Controls System Maintenance

## Adjusting the Control Handle Neutral Position

If the motion control levers do not align, or move easily into the console notch, adjustment is required. Adjust each lever, spring, and rod separately.

1. Disengage the PTO, move the motion control levers to the neutral locked position, and set the parking brake.
2. Stop the engine, remove the key, and wait for all moving parts to stop before leaving the operating position.
3. Unlatch the seat and tilt the seat forward.
4. Begin with either the left or right motion control lever.
5. Move the lever to the neutral position but not locked (Figure 73).
6. Pull the lever back until the clevis pin (on arm below pivot shaft) contacts the end of the slot (just beginning to put pressure on the spring) (Figure 73).
7. Check where the control lever is relative to notch in console (Figure 73). It should be centered allowing lever to pivot outward to the neutral lock position.

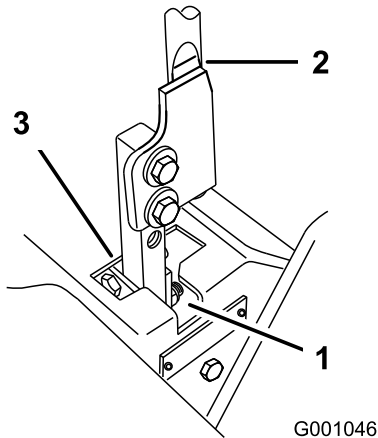

**Figure 73**

1. Neutral locked position
2. Control lever
3. Neutral position

10. Tighten the nut and jam nut (Figure 74).
11. Repeat for the opposite side of the machine.

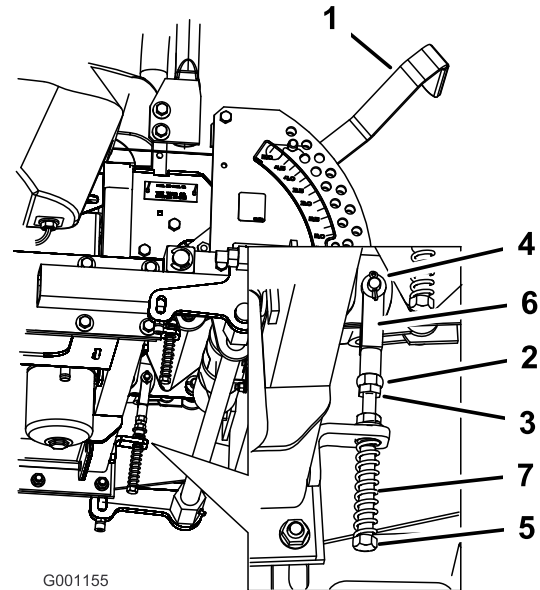

**Figure 74**

1. Height-of-cut lever
2. Nut against yoke
3. Jam nut
4. Clevis pin in slot
5. Adjustment bolt
6. Yoke
7. Spring

8. If adjustment is needed, loosen the nut and jam nut against the yoke (Figure 74).
9. Apply slight rearward pressure on the motion control lever, turn the head of the adjustment bolt in the appropriate direction until the control lever is centered in the neutral lock position (Figure 74).

**Note:** Keeping rearward pressure on the lever will keep the pin at the end of the slot and allow the adjustment bolt to move the lever to the appropriate position.

# Hydraulic System Maintenance

## Servicing the Hydraulic System

**Hydraulic Oil Type:** Toro® HYPR-OIL™ 500 hydraulic oil or Mobil® 1 15W-50

**Hydraulic System Oil Capacity:** 132 ounces (3.9l)

**Important:** Use oil specified. Other fluids could cause system damage.

## Checking the Hydraulic Fluid Level

**Service Interval:** After the first 8 hours

Every 25 hours

**Important:** Use oil specified or equivalent. Other fluids could cause system damage.

**Note:** The baffle inside the tank has 2 levels depending if the oil is warm or cold.

1. Position the machine on a level surface and set the parking brake.
2. Clean the area around filler neck of hydraulic tank (Figure 75).
3. Remove the cap from the filler neck. Look inside to check if there is fluid in the reservoir (Figure 75).
4. If there is no fluid, add fluid to the reservoir until it reaches the cold level of the baffle.
5. Run the machine at low idle for 15 minutes to allow any air to purge out of the system and warm the fluid. Refer to Starting and Stopping the Engine (page 20).
6. Recheck the fluid level while the fluid is warm. The fluid should be between cold and hot.
7. If required, add fluid to the hydraulic tank.

**Note:** The fluid level should be to the top of the hot level of the baffle, when the fluid is hot (Figure 75).

8. Install the cap on the filler neck.

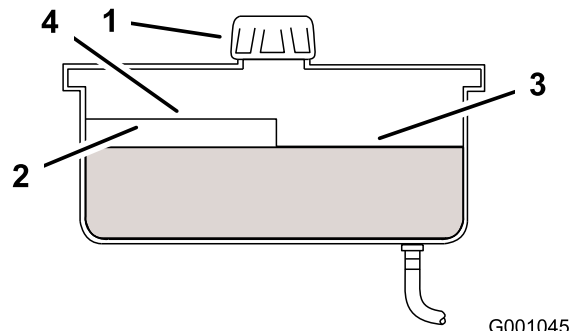

**Figure 75**

- |           |                          |
|-----------|--------------------------|
| 1. Cap    | 3. Cold fluid level-full |
| 2. Baffle | 4. Hot fluid level-full  |

## ⚠ WARNING

Hydraulic fluid escaping under pressure can penetrate your skin and cause injury.

- If hydraulic fluid is injected into the skin it must be surgically removed within a few hours by a doctor familiar with this type of injury. Gangrene may result if this is not done.
- Keep your body and hands away from pin hole leaks or nozzles that eject high pressure hydraulic fluid.
- Use cardboard or paper to find hydraulic leaks.
- Safely relieve all pressure in the hydraulic system before performing any work on the hydraulic system.
- Make sure that all hydraulic fluid hoses and lines are in good condition and all hydraulic connections and fittings are tight before applying pressure to hydraulic system.

## Replacing the Hydraulic Filter and Hydraulic Oil

**Service Interval:** After the first 25 hours

Every 250 hours—Change the hydraulic filter and hydraulic oil when using Mobil® 1 oil.

Every 500 hours—Change the hydraulic filter and hydraulic oil when using Toro® HYPR-OIL™ 500 hydraulic oil.

Use summer filter above 32°F (0°C)

Use winter filter below 32°F (0°C)

**Note:** At the yearly interval, change the hydraulic oil when the oil filter is changed.

1. Disengage the PTO, move the motion control levers to the neutral locked position, and set the parking brake.
2. Stop the engine, remove the key, and wait for all moving parts to stop before leaving the operating position.

**Important: Do not substitute automotive oil filter or severe hydraulic system damage may result.**

3. Place drain pan under filter, remove the old filter, and wipe the filter adapter gasket surface clean (Figure 76).

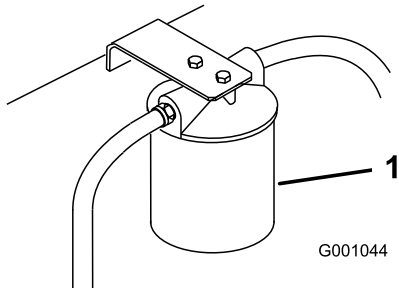

Figure 76

1. Hydraulic filter

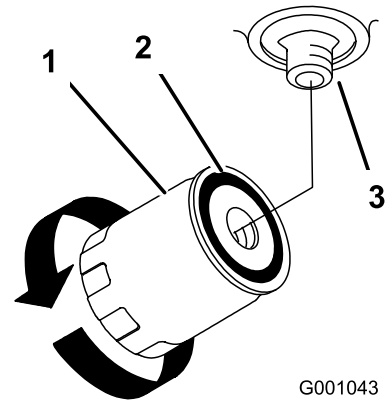

Figure 77

1. Hydraulic filter
2. Gasket
3. Adapter

## Bleeding the Hydraulic System

The traction system is self bleeding, however, it may be necessary to bleed the system if fluid is changed or after work is performed on the system.

4. Apply a thin coat hydraulic fluid to the rubber gasket on the replacement filter (Figure 77).
5. If changing the oil, allow the hydraulic oil to drain from the tank when the oil filter is removed.
6. Install the replacement hydraulic filter onto the filter adapter. Do not tighten.
7. Fill the hydraulic tank with hydraulic fluid until the fluid overflows the filter and then turn the oil filter clockwise until the rubber gasket contacts the filter adapter, then tighten the filter an additional 1/2 turn (Figure 77).
8. Clean up any spilled fluid.
9. Add fluid to the cold level of the baffle in the hydraulic tank.
10. Start the engine and let it run for about two minutes to purge air from the system. Stop the engine and check for leaks. If one or both wheels will not drive, refer to Bleeding the Hydraulic System (page 53).
11. Recheck the fluid level while the fluid is warm. The fluid should be between cold and hot.
12. If required, add fluid to the hydraulic tank. Do not overfill.

1. Raise rear of the machine so wheels are off the ground and support it with jack stands.
2. Start the engine and run at low idle speed. Engage the lever and traction on one side and spin the wheel by hand.
3. When the wheel begins to spin on its own, keep it engaged until wheel drives smoothly. (minimum 2 minutes)
4. Check hydraulic fluid level and add as required to maintain proper level.
5. Repeat this procedure on the opposite wheel.

## Checking the Hydraulic Hoses

**Service Interval:** Every 100 hours

Check the hydraulic hoses for leaks, loose fittings, kinked lines, loose mounting supports, wear, weather, and chemical deterioration. Make necessary repairs before operating.

**Note:** Keep areas around the hydraulic system clean from grass and debris build up.

## ⚠ WARNING

Hydraulic fluid escaping under pressure can penetrate skin and cause injury.

- If hydraulic fluid is injected into the skin it must be surgically removed within a few hours by a doctor familiar with this type of injury. Gangrene may result if this is not done.
- Keep body and hands away from pin hole leaks or nozzles that eject high pressure hydraulic fluid.
- Use cardboard or paper to find hydraulic leaks.
- Safely relieve all pressure in the hydraulic system before performing any work on the hydraulic system.
- Make sure all hydraulic fluid hoses and lines are in good condition and all hydraulic connections and fittings are tight before applying pressure to hydraulic system.

## Setting the Hydraulic Pump Neutral Position

**Note:** Adjust the handle neutral first. That needs to be correct before the following adjustment can be made.

This adjustment must be made with drive wheels turning.

## ⚠ DANGER

Mechanical or hydraulic jacks may fail to support machine and cause a serious injury.

- Use jack stand when supporting machine.
- Do not use hydraulic jacks.

## ⚠ WARNING

Engine must be running so motion control adjustment can be performed. Contact with moving parts or hot surfaces may cause personal injury.

Keep hands, feet, face, clothing and other body parts away from rotating parts, muffler and other hot surfaces.

1. Raise the frame and block up the machine so drive wheels can rotate freely.
2. Disconnect the electrical connector from the seat safety switch. Temporarily install a jumper wire across terminals in the wiring harness connector.
3. Unlatch the seat and slide seat forward.
4. Disconnect the seat rod and tilt the seat fully forward.

## Setting the Right-hand Hydraulic Pump Neutral Position

1. Start the engine, open the throttle 1/2 way and release the parking brake. Refer to Starting and Stopping the Engine (page 20).

**Note:** The motion control lever must be in the neutral position while making any adjustments.

2. Adjust the pump rod length by rotating the knob, in the appropriate direction, until the wheel is still or slightly creeping in reverse (Figure 78).
3. Move the motion control lever forward and reverse, then back to neutral. The wheel must stop turning or slightly creep in reverse.
4. Open the throttle to the fast position. Make sure that the wheel remains stopped or slightly creeps in reverse, adjust if necessary.

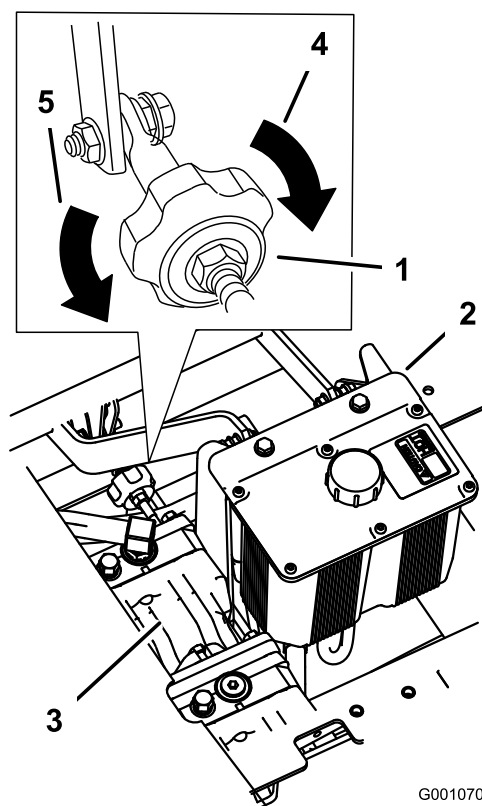

Figure 78

1. Tracking knob
2. Hydraulic tank
3. Hydraulic pumps
4. Turn this way to track right
5. Turn this way to track left

## Setting the Left-hand Hydraulic Pump Neutral Position

1. Loosen the locknuts at the ball joints on the pump control rod (Figure 79).
2. Start the engine, open the throttle 1/2 way, and release the parking brake. Refer to Starting and Stopping the Engine (page 20).

**Note:** The motion control lever must be in the neutral position while making any adjustments.

**Note:** The front nut on the pump rod has left-hand threads.

3. Adjust the pump rod length by rotating double nuts on rod, in the appropriate direction, until wheel is still or slightly creeps in reverse (Figure 79).
4. Move the motion control lever forward and reverse, then back to neutral. The wheel must stop turning or slightly creep in reverse.
5. Open the throttle to the fast position. Make sure that the wheel remains stopped or slightly creeps in reverse, adjust if necessary.
6. Tighten the locknuts at the ball joints (Figure 79).

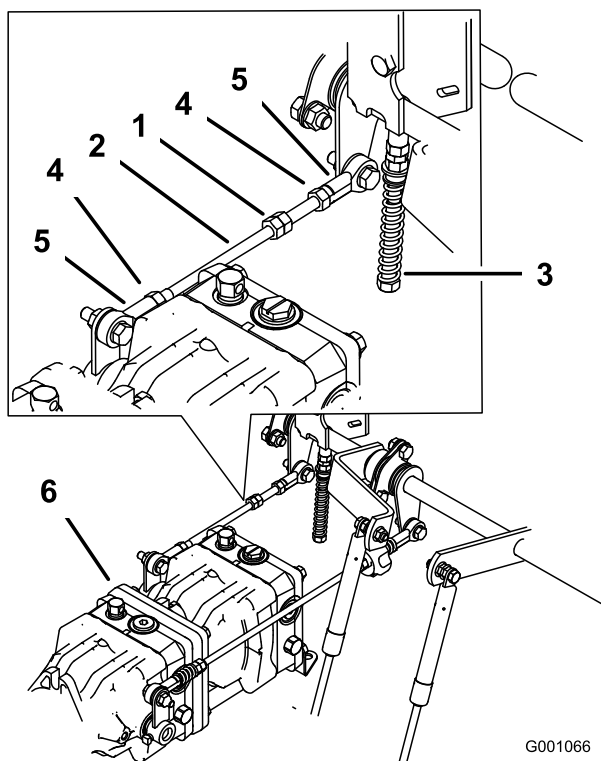

**Figure 79**

- |                    |               |
|--------------------|---------------|
| 1. Double nuts     | 4. Locknut    |
| 2. Pump rod        | 5. Ball joint |
| 3. Adjustment bolt | 6. Pumps      |

## ⚠ WARNING

The electrical system will not perform the proper safety shut off process with a jumper wire installed.

- Remove the jumper wire from the wire harness connector and plug the connector into the seat switch when an adjustment is completed.
  - Never operate this unit with a jumper installed and the seat switch bypassed.
7. After both of the pump neutrals are set, shut off the machine.
  8. Remove the jumper wire from the wire harness connector and plug the connector into the seat switch.
  9. Install the seat rod and lower the seat into position.
  10. Remove the jack stands.

# Mower Deck Maintenance

## Leveling the Mower at Three Positions

### Setting Up the Machine

1. Position mower on a flat surface.
2. Disengage the PTO, move the motion control levers to the neutral locked position, and set the parking brake.
3. Stop the engine, remove the key, and wait for all moving parts to stop before leaving the operating position.
4. Check tire pressure of all 4 tires. If needed, adjust to 90 kPa (13 psi).
5. Lower the mower to the 76 mm (3 inch) height-of-cut position.
6. Inspect the 4 chains. The chains need to have tension.
  - If one rear chain is loose, lower (loosen) the front support arm on the same side. Refer to Adjusting the Front-to-Rear Mower Pitch (page 57).
  - If one front chain is loose, raise (tighten) the front support arm for that chain. Refer to Adjusting the Front-to-Rear Mower Pitch (page 57).

### Leveling the Mower Side-to-Side

1. Position the **right** blade side-to-side (Figure 80).

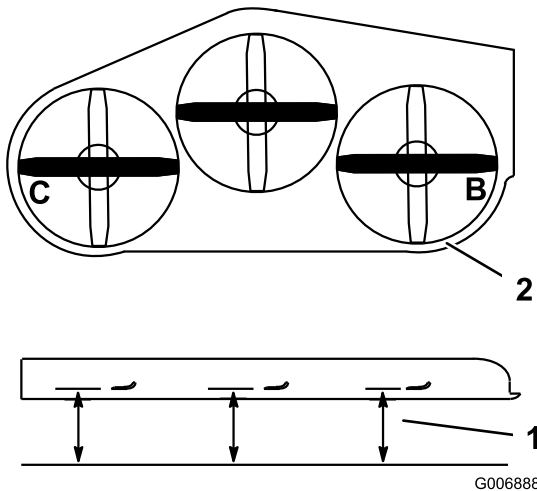

Figure 80

1. Measure here from the blade to a hard surface.
2. Measure at B and C.

2. Measure the right blade at the **B** location, from a level surface to the cutting edge of the blade tip (Figure 80).
3. Record this measurement. This measurement needs to be 80 to 83 mm (3-1/8 to 3-1/4 inches).

4. Position the left blade side-to-side (Figure 80).
5. Measure the left blade at the **C** location (Figure 80), from a level surface to the cutting edge of the blade tip.
6. Record this measurement. This measurement needs to be 80 to 83 mm (3-1/8 to 3-1/4 inches).
7. If the measurements at positions **B** or **C** are not correct, loosen the bolt attaching the rear chain to the rear support arm (Figure 81).

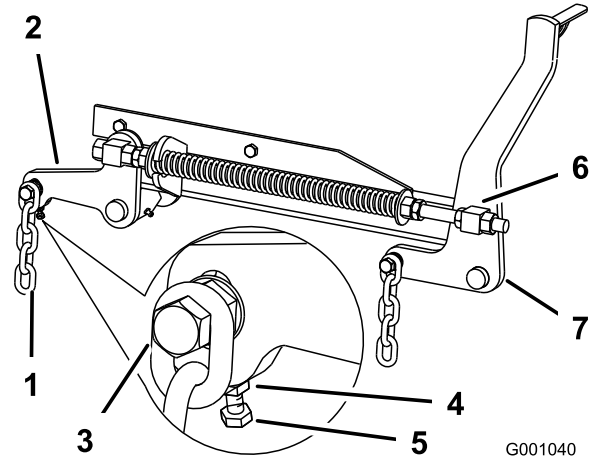

Figure 81

- |                     |                      |
|---------------------|----------------------|
| 1. Rear chain       | 5. Adjustment bolt   |
| 2. Rear support arm | 6. Front swivel      |
| 3. Bolt             | 7. Front support arm |
| 4. Jam nut          |                      |

8. Loosen the jam nut under the rear support arm and adjust the adjustment bolt to get a measurement of 80 to 83 mm (3-1/8 to 3-1/4 inches)(Figure 81).
 

**Note:** It is recommended that both sides of the mower are adjusted the same distance.
9. Tighten the jam nut under the rear support arm and tighten the bolt securing the chain to the rear support arm.
10. Adjust the opposite side if needed.



## Adjusting the Front-to-Rear Mower Pitch

1. Position the right blade front-to-rear (Figure 82).
2. Measure the right blade at the **A** location, from a level surface to the cutting edge of the blade tip (Figure 82).

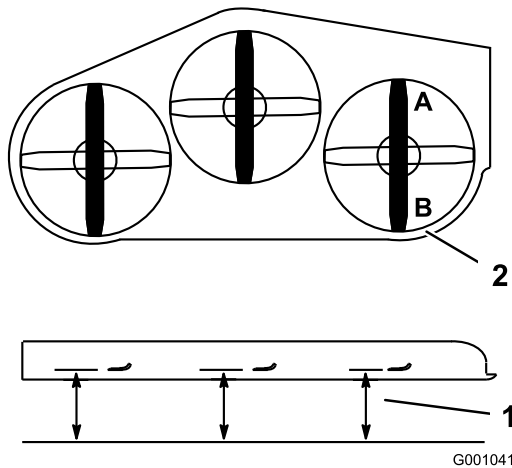

Figure 82

1. Measure here from the blade to a hard surface.
2. Measure at A and B.
3. Record this measurement.
4. Measure the right blade at the **B** location, from a level surface to the cutting edge of the blade tip (Figure 82).
5. Record this measurement.
6. The mower blade should be a 6 to 10 mm (1/4 to 3/8 inch) lower at position **A** than at position **B** (Figure 82). If it is not correct, proceed to the following steps.
 

**Note:** Both of the front swivels need to be adjusted the same amount to maintain equal chain tension.
7. Loosen the front swivel jam nuts, at the front of the right and left swivels, approximately a 13 mm (1/2 inch) (Figure 81).
8. Adjust the lift nuts on both the left and the right side of the machine to achieve 6 to 10 mm (1/4 to 3/8 inch) lower in front at **A** than in the rear at **B** (Figure 81).
9. Tighten both swivel jam nuts against the front swivel to lock the height.
10. Check to make sure that there is equal tension on the chains and adjust again if needed.

## Adjusting the Compression Spring

1. Raise the mower lift lever to the transport position.
2. Check the distance between the two large washers, it needs to be 28.2 cm (11-1/8 inches) for 52 inch mower decks and 26.7 cm (10-1/2 inches) for 60 inch mower decks (Figure 83).
3. Adjust this distance, by loosening the spring jam nut and turning the nut in front of each spring (Figure 83).

Turning the nut clockwise will shorten the spring; counter-clockwise will lengthen the spring.

4. Lock the nut into position by tightening the spring jam nut (Figure 83).

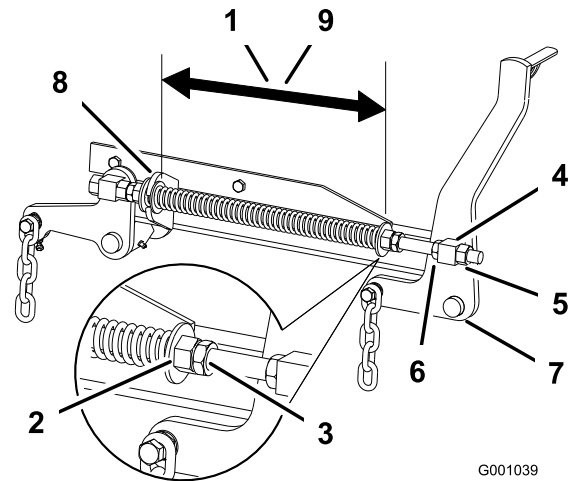

Figure 83

1. 28.2 cm (11-1/8 inch) between the large washers for 52 inch mower decks
2. Front nut
3. Spring jam nut
4. Front swivel
5. Swivel jam nut
6. Lift nut
7. Front support arm
8. Large washer
9. 26.7 cm (10-1/2 inch) between the large washers for 60 inch mower decks

## Servicing the Cutting Blades

Maintain sharp blades throughout the cutting season because sharp blades cut cleanly without tearing or shredding the grass blades. Tearing and shredding turns grass brown at the edges, which slows growth and increases the chance of disease.

Check the cutter blades daily for sharpness, and for any wear or damage. File down any nicks and sharpen the blades as necessary. If a blade is damaged or worn, replace it immediately with a genuine Toro replacement blade. For convenient sharpening and replacement, you may want to keep extra blades on hand.

### **▲ DANGER**

**A worn or damaged blade can break, and a piece of the blade could be thrown into the operator's or bystander's area, resulting in serious personal injury or death.**

- **Inspect the blade periodically for wear or damage.**
- **Replace a worn or damaged blade.**

## Before Inspecting or Servicing the Blades

Park the machine on a level surface, disengage the blade control (PTO), and set the parking brake. Turn the ignition key to the Off position. Remove the key.

## Inspecting the Blades

**Service Interval:** Before each use or daily

1. Inspect the cutting edges (Figure 84). If the edges are not sharp or have nicks, remove and sharpen the blades. Refer to Sharpening the Blades (page 59).
2. Inspect the blades, especially the curved area (Figure 84). If you notice any damage, wear, or a slot forming in this area (Figure 84), immediately install a new blade.

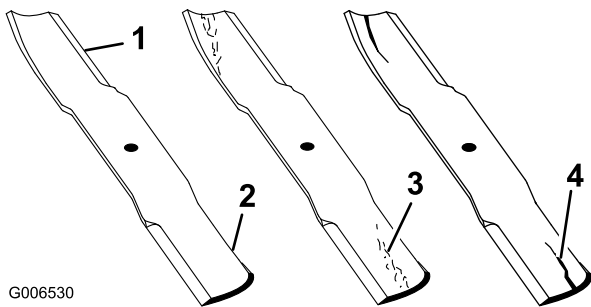

**Figure 84**

- |                 |                      |
|-----------------|----------------------|
| 1. Cutting edge | 3. Wear/slot forming |
| 2. Curved area  | 4. Crack             |

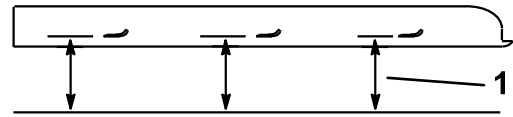
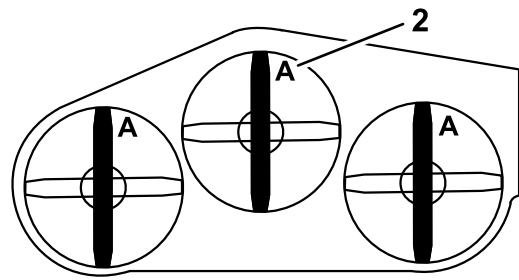

G000975

**Figure 85**

1. Measure here from blade
2. Position A to hard surface

4. Rotate the opposite ends of the blades forward.
5. Measure from a level surface to the cutting edge of the blades at the same position as in step 3 above. The difference between the dimensions obtained in steps 3 and 4 must not exceed 3 mm (1/8 inch). If this dimension exceeds 3 mm (1/8 inch), the blade is bent and must be replaced; refer to Removing the Blades (page 58) and Installing the Blades (page 59).

### **⚠ WARNING**

A blade that is bent or damaged could break apart and could seriously injure or kill you or bystanders.

- Always replace bent or damaged blade with a new blade.
- Never file or create sharp notches in the edges or surfaces of blade.

## Checking for Bent Blades

1. Disengage the PTO, move the motion control levers to the neutral locked position, and set the parking brake.
2. Stop the engine, remove the key, and wait for all moving parts to stop before leaving the operating position.
3. Rotate the blades until the ends face forward and backward (Figure 85). Measure from a level surface to the cutting edge, position A, of the blades (Figure 85). Note this dimension.

## Removing the Blades

Blades must be replaced if a solid object is hit, if the blade is out of balance or is bent. To ensure optimum performance and continued safety conformance of the machine, use genuine Toro replacement blades. Replacement blades made by other manufacturers may result in non-conformance with safety standards.

### **⚠ WARNING**

Contact with a sharp blade can cause serious injury.

Wear gloves or wrap sharp edges of the blade with a rag.

1. Hold the blade end using a rag or thick padded glove.

- Remove the blade bolt, curved washer, and blade from the spindle shaft (Figure 88).

## Sharpening the Blades

### ⚠ WARNING

When sharpening blades, pieces of the blade could be thrown and cause serious injury.

Wear proper eye protection when sharpening blades.

- Use a file to sharpen the cutting edge at both ends of the blade (Figure 86). Maintain the original angle. The blade retains its balance if the same amount of material is removed from both cutting edges.

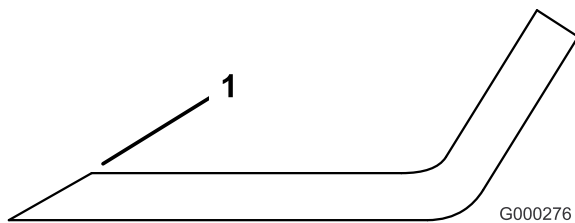

Figure 86

- Sharpen at original angle

- Check the balance of the blade by putting it on a blade balancer (Figure 87). If the blade stays in a horizontal position, the blade is balanced and can be used. If the blade is not balanced, file some metal off the end of the sail area only (Figure 88). Repeat this procedure until the blade is balanced.

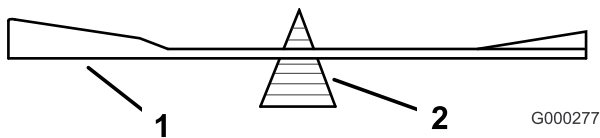

Figure 87

- Blade
- Balancer

## Installing the Blades

- Install the blade onto the spindle shaft (Figure 88).

**Important:** The curved part of the blade must be pointing upward toward the inside of the mower to ensure proper cutting.

- Install the curved washer and blade bolt. The curved washer cone must be installed toward the bolt head (Figure 88). Torque the blade bolt to 85-110 ft-lb (115-150 N-m).

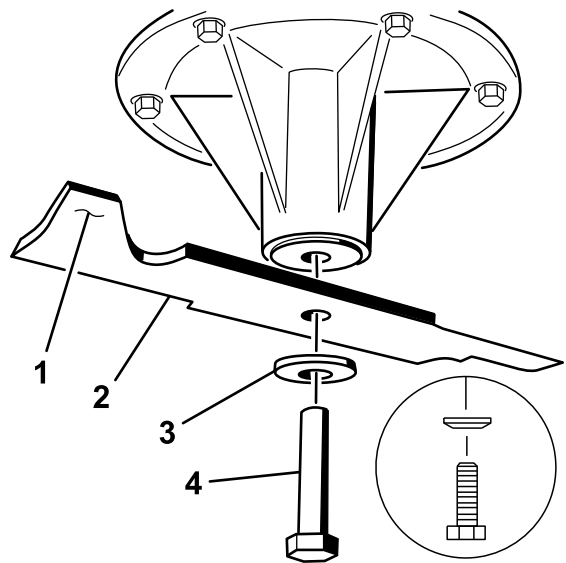

Figure 88

- Sail area of the blade
- Blade
- Curved washer
- Blade bolt

## Replacing the Grass Deflector

### ⚠ WARNING

An uncovered discharge opening could allow the lawn mower to throw objects in the operator's or bystander's direction and result in serious injury. Also, contact with the blade could occur.

- Never operate the machine unless you install a cover plate, a mulch plate, or a grass chute and catcher.
- Make sure that the grass deflector is in the down position.

- Remove the locknut, bolt, spring, and spacer holding the deflector to the pivot brackets (Figure 89). Remove the damaged or worn grass deflector.
- Place the spacer and spring onto grass deflector. Place the L end of spring behind deck edge.

**Note:** Make sure the L end of the spring is installed behind the deck edge before installing the bolt as shown in Figure 89.

- Install the bolt and nut. Place the J hook end of the spring around the grass deflector (Figure 89).

**Important:** The grass deflector must be able to lower down into position. Lift the deflector up to test that it lowers into the full down position.

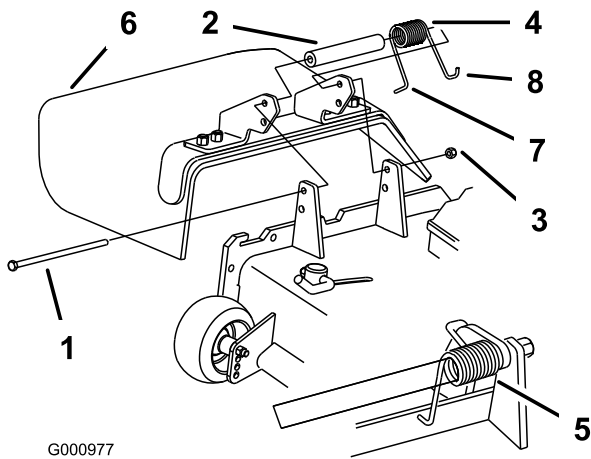

**Figure 89**

- |            |   |
|------------|---|
| 1. Bolt    | 5. Spring installed   |
| 2. Spacer  | 6. Grass deflector  |
| 3. Locknut | 7. L end of spring, place behind deck edge before installing bolt |
| 4. Spring  | 8. J hook end of spring   |

## Cleaning

### Cleaning Under the Mower

**Service Interval:** Before each use or daily

Remove the grass buildup under the mower daily.

1. Disengage the PTO, move the motion control levers to the neutral locked position, and set the parking brake.
2. Stop the engine, remove the key, and wait for all moving parts to stop before leaving the operating position.
3. Raise the mower to the transport position.

### Waste Disposal

Engine oil, batteries, hydraulic oil, and engine coolant are pollutants to the environment. Dispose of these according to your state and local regulations.

# Storage

## Cleaning and Storage

1. Disengage the power take off (PTO), set the parking brake, and turn the ignition key to the Off position. Remove the key.
2. Remove grass clippings, dirt, and grime from the external parts of the entire machine, especially the engine and hydraulic system. Clean dirt and chaff from the outside of the engine cylinder head fins and blower housing.

**Important:** You can wash the machine with mild detergent and water. Do not pressure wash the machine. Avoid excessive use of water, especially near the control panel, engine, hydraulic pumps, and motors.

3. Check the brake; refer to Adjusting the Parking Brake (page 47).  
Service the air cleaner; refer to Engine Maintenance (page 34).
4. Grease the machine; refer to Lubrication (page 32).
5. Change the crankcase oil; refer to Servicing the Engine Oil (page 35).  
Check the tire pressure; refer to Drive System Maintenance (page 42).
6. Change the hydraulic filter; refer to Hydraulic System Maintenance (page 52).
7. Charge the battery; refer to Electrical System Maintenance (page 40).
8. Scrape any heavy buildup of grass and dirt from the underside of the mower, then wash the mower with a garden hose.

**Note:** Run the machine with the PTO engaged and the engine at high idle for 2 to 5 minutes after washing.

9. Check the condition of the blades; refer to Servicing the Cutting Blades (page 57).

Prepare the machine for storage when non-use occurs over 30 days. Prepare the machine for storage as follows:

- A. Add a petroleum based stabilizer/conditioner to fuel in the tank. Follow mixing instructions from the stabilizer manufacturer. Do not use an alcohol based stabilizer (ethanol or methanol).

**Note:** A fuel stabilizer/conditioner is most effective when mixed with fresh fuel and used at all times.

- B. Run the engine to distribute conditioned fuel through the fuel system (5 minutes).
- C. Stop the engine, allow it to cool, and drain the fuel tank; refer to Fuel System Maintenance (page 38).

- D. Restart the engine and run it until it stops.
- E. Dispose of fuel properly. Recycle as per local codes.

**Important:** Do not store stabilizer/conditioned fuel over 90 days.

10. Check and tighten all bolts, nuts, and screws. Repair or replace any part that is damaged.
11. Paint all scratched or bare metal surfaces. Paint is available from your Authorized Service Dealer.
12. Store the machine in a clean, dry garage or storage area. Remove the key from the ignition switch and keep it out of reach of children or other unauthorized users. Cover the machine to protect it and keep it clean.

# Troubleshooting

Problem	Possible Cause	Corrective Action
The starter does not crank.	<ol style="list-style-type: none"> <li>1. The blade control (PTO) is engaged.</li> <li>2. The parking brake is not on.</li> <li>3. The operator is not seated.</li> <li>4. The battery is dead.</li> <li>5. The electrical connections are corroded or loose.</li> <li>6. The fuse is blown.</li> <li>7. The relay or switch is defective.</li> </ol>	<ol style="list-style-type: none"> <li>1. Move the blade control (PTO) to the disengaged position.</li> <li>2. Set the parking brake.</li> <li>3. Sit on the seat.</li> <li>4. Charge the battery.</li> <li>5. Check the electrical connections for good contact.</li> <li>6. Replace the fuse.</li> <li>7. Contact an Authorized Service Dealer.</li> </ol>
The engine will not start, starts hard, or fails to keep running.	<ol style="list-style-type: none"> <li>1. The fuel tank is empty.</li> <li>2. The air cleaner is dirty.</li> <li>3. Dirt is in the fuel filter.</li> <li>4. Dirt, water, or stale fuel is in the fuel system.</li> </ol>	<ol style="list-style-type: none"> <li>1. Fill the fuel tank with fuel.</li> <li>2. Clean or replace the air cleaner element.</li> <li>3. Replace the fuel filter.</li> <li>4. Contact an Authorized Service Dealer.</li> </ol>
The engine loses power.	<ol style="list-style-type: none"> <li>1. The engine load is excessive.</li> <li>2. The air cleaner is dirty.</li> <li>3. The oil level in the crankcase is low.</li> <li>4. The cooling fins and air passages above the engine are plugged.</li> <li>5. The vent hole in the fuel cap is plugged.</li> <li>6. Dirt is in the fuel filter.</li> <li>7. Dirt, water, or stale fuel is in the fuel system.</li> </ol>	<ol style="list-style-type: none"> <li>1. Reduce the ground speed.</li> <li>2. Clean the air cleaner element.</li> <li>3. Add oil to the crankcase.</li> <li>4. Remove the obstruction from the cooling fins and air passages.</li> <li>5. Clean or replace the fuel cap.</li> <li>6. Replace the fuel filter.</li> <li>7. Contact an Authorized Service Dealer.</li> </ol>
The engine overheats.	<ol style="list-style-type: none"> <li>1. The engine load is excessive.</li> <li>2. The oil level in the crankcase is low.</li> <li>3. The cooling fins and air passages above the engine are plugged.</li> </ol>	<ol style="list-style-type: none"> <li>1. Reduce the ground speed.</li> <li>2. Add oil to the crankcase.</li> <li>3. Remove the obstruction from the cooling fins and air passages.</li> </ol>
The machine does not drive.	<ol style="list-style-type: none"> <li>1. The by pass valve is not closed tight.</li> <li>2. The drive or pump belt is worn, loose or broken.</li> <li>3. The drive or pump belt is off a pulley.</li> <li>4. The idler spring is broken or missing.</li> <li>5. The hydraulic fluid level is low or too hot.</li> </ol>	<ol style="list-style-type: none"> <li>1. Tighten the by pass valve.</li> <li>2. Change the belt.</li> <li>3. Change the belt.</li> <li>4. Replace the spring.</li> <li>5. Add hydraulic fluid to the reservoir or let it cool down.</li> </ol>
There is abnormal vibration.	<ol style="list-style-type: none"> <li>1. The cutting blade(s) is/are bent or unbalanced.</li> <li>2. The blade mounting bolt is loose.</li> <li>3. The engine mounting bolts are loose.</li> <li>4. The engine pulley, idler pulley, or blade pulley is loose.</li> <li>5. The engine pulley is damaged.</li> <li>6. The blade spindle is bent.</li> <li>7. The motor mount is loose or worn.</li> </ol>	<ol style="list-style-type: none"> <li>1. Install new cutting blade(s).</li> <li>2. Tighten the blade mounting bolt.</li> <li>3. Tighten the engine mounting bolts.</li> <li>4. Tighten the appropriate pulley.</li> <li>5. Contact an Authorized Service Dealer.</li> <li>6. Contact an Authorized Service Dealer.</li> <li>7. Contact an Authorized Service Dealer.</li> </ol>

Problem	Possible Cause	Corrective Action
The cutting height is uneven.	<ol style="list-style-type: none"> <li>1. The cutting blade(s) is/are not sharp.</li> <li>2. The cutting blade(s) is/are bent.</li> <li>3. The mower deck is not level.</li> <li>4. The underside of mower is dirty.</li> <li>5. The tire pressure is not correct.</li> <li>6. The blade spindle is bent.</li> </ol>	<ol style="list-style-type: none"> <li>1. Sharpen the blade(s).</li> <li>2. Install new cutting blade(s).</li> <li>3. Level the mower deck from side-to-side and front-to-rear.</li> <li>4. Clean the underside of the mower.</li> <li>5. Adjust the tire pressure.</li> <li>6. Contact an Authorized Service Dealer.</li> </ol>
The cutting blades do not rotate.	<ol style="list-style-type: none"> <li>1. The drive belt is worn, loose or broken.</li> <li>2. The drive belt is off pulley.</li> <li>3. The mower deck belt is worn, loose or broken.</li> <li>4. The mower deck belt came off a pulley.</li> <li>5. The idler spring is broken or missing.</li> </ol>	<ol style="list-style-type: none"> <li>1. Check the belt tension.</li> <li>2. Install the drive belt and check adjusting shafts and belt guides for correct position.</li> <li>3. Install a new mower deck belt.</li> <li>4. Install mower deck belt and check the idler pulley, idler arm and spring for the correct position and function.</li> <li>5. Replace the spring.</li> </ol>





**Notes:**

**Notes:**

## International Distributor List

<b>Distributor:</b>	<b>Country:</b>	<b>Phone Number:</b>	<b>Distributor:</b>	<b>Country:</b>	<b>Phone Number:</b>
Atlantis Su ve Sulama Sisstemleri Lt	Turkey	90 216 344 86 74	Maquiver S.A.	Colombia	57 1 236 4079
Balama Prima Engineering Equip.	Hong Kong	852 2155 2163	Maruyama Mfg. Co. Inc.	Japan	81 3 3252 2285
B-Ray Corporation	Korea	82 32 551 2076	Agrolanc Kft	Hungary	36 27 539 640
Casco Sales Company	Puerto Rico	787 788 8383	Mountfield a.s.	Czech Republic	420 255 704 220
Ceres S.A.	Costa Rica	506 239 1138	Munditol S.A.	Argentina	54 11 4 821 9999
CSSC Turf Equipment (pvt) Ltd.	Sri Lanka	94 11 2746100	Oslinger Turf Equipment SA	Ecuador	593 4 239 6970
Cyril Johnston & Co.	Northern Ireland	44 2890 813 121	Oy Hako Ground and Garden Ab	Finland	358 987 00733
Equiver	Mexico	52 55 539 95444	Parkland Products Ltd.	New Zealand	64 3 34 93760
Femco S.A.	Guatemala	502 442 3277	Prato Verde S.p.A.	Italy	39 049 9128 128
G.Y.K. Company Ltd.	Japan	81 726 325 861	Prochaska & Cie	Austria	43 1 278 5100
Geomechaniki of Athens	Greece	30 10 935 0054	RT Cohen 2004 Ltd.	Israel	972 986 17979
Guandong Golden Star	China	86 20 876 51338	Riversa	Spain	34 9 52 83 7500
Hako Ground and Garden	Sweden	46 35 10 0000	Sc Svend Carlsen A/S	Denmark	45 66 109 200
Hako Ground and Garden	Norway	47 22 90 7760	Solvert S.A.S.	France	33 1 30 81 77 00
Hayter Limited (U.K.)	United Kingdom	44 1279 723 444	Spypros Stavrinides Limited	Cyprus	357 22 434131
Hydroturf Int. Co Dubai	United Arab Emirates	97 14 347 9479	Surge Systems India Limited	India	91 1 292299901
Hydroturf Egypt LLC	Egypt	202 519 4308	T-Markt Logistics Ltd.	Hungary	36 26 525 500
Irriamc	Portugal	351 21 238 8260	Toro Australia	Australia	61 3 9580 7355
Irrigation Products Int'l Pvt Ltd.	India	0091 44 2449 4387	Toro Europe NV	Belgium	32 14 562 960
Jean Heybroek b.v.	Netherlands	31 30 639 4611			

### European Privacy Notice

#### The Information Toro Collects

Toro Warranty Company (Toro) respects your privacy. In order to process your warranty claim and contact you in the event of a product recall, we ask you to share certain personal information with us, either directly or through your local Toro company or dealer.

The Toro warranty system is hosted on servers located within the United States where privacy law may not provide the same protection as applies in your country.

**BY SHARING YOUR PERSONAL INFORMATION WITH US, YOU ARE CONSENTING TO THE PROCESSING OF YOUR PERSONAL INFORMATION AS DESCRIBED IN THIS PRIVACY NOTICE.**

#### The Way Toro Uses Information

Toro may use your personal information to process warranty claims, to contact you in the event of a product recall and for any other purpose which we tell you about. Toro may share your information with Toro's affiliates, dealers or other business partners in connection with any of these activities. We will not sell your personal information to any other company. We reserve the right to disclose personal information in order to comply with applicable laws and with requests by the appropriate authorities, to operate our systems properly or for our own protection or that of other users.

#### Retention of your Personal Information

We will keep your personal information as long as we need it for the purposes for which it was originally collected or for other legitimate purposes (such as regulatory compliance), or as required by applicable law.

#### Toro's Commitment to Security of Your Personal Information

We take reasonable precautions in order to protect the security of your personal information. We also take steps to maintain the accuracy and current status of personal information.

#### Access and Correction of your Personal Information

If you would like to review or correct your personal information, please contact us by email at [legal@toro.com](mailto:legal@toro.com).

### Australian Consumer Law

Australian customers will find details relating to the Australian Consumer Law either inside the box or at your local Toro Dealer.



# The Toro Total Coverage Warranty

A Limited Warranty (see warranty periods below)

Landscape Contractor Equipment (LCE)

## Conditions and Products Covered

The Toro Company and its affiliate, Toro Warranty Company, pursuant to an agreement between them, jointly promise to the original purchaser to repair the Toro Products listed below if defective in materials or workmanship.

The following time periods apply from the date of purchase by the original owner:

Products	Warranty Period
21 in. Mowers • Engines <sup>4</sup>	1 year Commercial Use Honda – 1 years Kawasaki – 3 years
21 in. Mowers • Engines <sup>4</sup>	2 years Residential Use <sup>1</sup> Honda – 2 years Kawasaki – 3 years
30 in. Mowers • Engines <sup>4</sup>	2 years Commercial and Residential Use <sup>1</sup> Kawasaki – 3 years
Mid-Size Walk-Behind Mowers • Engines <sup>4</sup>	2 years Kawasaki – 3 years
Grand Stand® Mowers • Engines <sup>4</sup>  • Frame	5 years or 1,200 hours <sup>2</sup> Kawasaki – 3 years Kohler EFI – 3 years Lifetime (original owner only) <sup>3</sup>
Z Master® 2000 Series Mowers • Engines <sup>4</sup> • Frame	4 years or 500 hours <sup>2</sup> Kawasaki – 3 years Lifetime (original owner only) <sup>3</sup>
Z Master® 3000 Series Mowers • Engines <sup>4</sup> • Frame	5 years or 1,200 hours <sup>2</sup> Kawasaki – 3 years Lifetime (original owner only) <sup>3</sup>
Z Master® 5000 Series Mowers • Engines <sup>4</sup>  • Frame	5 years or 1,200 hours <sup>2</sup> Kohler Command – 2 years Kohler EFI – 3 years Lifetime (original owner only) <sup>3</sup>
Z Master® 6000 Series Mowers • Engines <sup>4</sup>  • Frame	5 years or 1,200 hours <sup>2</sup> Kawasaki – 3 years Kohler Command – 2 years Kohler EFI – 3 years Lifetime (original owner only) <sup>3</sup>
Z Master®7000 Series Mowers • Engines <sup>4</sup>  • Frame	4 years or 1,200 hours <sup>2</sup> Kubota – 2 years Briggs & Stratton – 2 years Lifetime (original owner only) <sup>3</sup>
All Mowers • Battery	90 days Parts and Labor 1 year Parts only
• Belts and Tires	90 days
• Attachments	1 year

<sup>1</sup>Residential use means use of the product on the same lot as your home. Use at more than one location is considered commercial use and the commercial warranty would apply.

<sup>2</sup>Whichever occurs first.

<sup>3</sup>Lifetime Frame Warranty - If the main frame, consisting of the parts welded together to form the tractor structure that other components such as the engine are secured to, cracks or breaks in normal use, it will be repaired or replaced, at Toro's option, under warranty at no cost for parts and labor. Frame failure due to misuse or abuse and failure or repair required due to rust or corrosion are not covered.

<sup>4</sup>Some engines used on Toro Products are warranted by the engine manufacturer.

This warranty includes the cost of parts and labor, but you must pay transportation costs.

## Instructions for Obtaining Warranty Service

If you think that your Toro Product contains a defect in materials or workmanship, follow this procedure:

1. Contact any Authorized Toro Service Dealer to arrange service at their dealership. To locate a dealer convenient to you, refer to the Yellow Pages of your telephone directory (look under "Lawn Mowers") or access our web site at [www.Toro.com](http://www.Toro.com). You may also call the numbers listed in item #3 to use the 24-hour Toro Dealer locator system.
2. Bring the product and your proof of purchase (sales receipt) to the Service Dealer. The dealer will diagnose the problem and determine if it is covered under warranty.
3. If for any reason you are dissatisfied with the Service Dealer's analysis or with the assistance provided, contact us at:

RLC Customer Care Department  
Toro Warranty Company  
8111 Lyndale Avenue South  
Bloomington, MN 55420-1196  
888-865-5676 (U.S. Customers)  
888-865-5691 (Canada customers)

## Owner Responsibilities

You must maintain your Toro Product by following the maintenance procedures described in the *Operator's Manual*. Such routine maintenance, whether performed by a dealer or by you, is at your expense.

## Items and Conditions Not Covered

There is no other express warranty except for special emission system and engine warranty coverage on some products. This express warranty does not cover the following:

- Cost of regular maintenance service or wear parts, such as filters, fuel, lubricants, tune-up parts, blade sharpening, brake and clutch adjustments.
- Any product or part which has been altered or misused and requires replacement or repair due to normal wear, accidents, or lack of proper maintenance.
- Repairs necessary due to improper fuel, contaminants in the fuel system, or failure to properly prepare the fuel system prior to any period of non-use over three months.
- Pickup and delivery charges.

## General Conditions

All repairs covered by these warranties must be performed by an Authorized Toro Service Dealer using Toro approved replacement parts.

**Neither The Toro Company nor Toro Warranty Company is liable for indirect, incidental or consequential damages in connection with the use of the Toro Products covered by this warranty, including any cost or expense of providing substitute equipment or service during reasonable periods of malfunction or non-use pending completion of repairs under this warranty.**

**All implied warranties of merchantability (that the product is fit for ordinary use) and fitness for use (that the product is fit for a particular purpose) are limited to the duration of the express warranty.**

**Some states do not allow exclusions of incidental or consequential damages, or limitations on how long an implied warranty lasts, so the above exclusions and limitations may not apply to you.**

This warranty gives you specific legal rights, and you may also have other rights which vary from state to state.

## Countries Other than the United States or Canada

Customers who have purchased Toro products outside the United States or Canada should contact their Toro Distributor (Dealer) to obtain guarantee policies for your country, province, or state. If for any reason you are dissatisfied with your Distributor's service or have difficulty obtaining guarantee information, contact the Toro importer. If all other remedies fail, you may contact us at Toro Warranty Company.

**Australian Consumer Law:** Australian customers will find details relating to the Australian Consumer Law either inside the box or at your local Toro Dealer.