



Count on it.

Operator's Manual

Groundsmaster® 3500-G Traction Unit

Model No. 30809—Serial No. 313000001 and Up



This product complies with all relevant European directives, for details please see the separate product specific Declaration of Conformity (DOC) sheet.

⚠ WARNING

**CALIFORNIA
Proposition 65 Warning**

This product contains a chemical or chemicals known to the State of California to cause cancer, birth defects, or reproductive harm.

The engine exhaust from this product contains chemicals known to the State of California to cause cancer, birth defects, or other reproductive harm.

Important: This engine is not equipped with a spark arrester muffler. It is a violation of California Public Resource Code Section 4442 to use or operate the engine on any forest-covered, brush-covered, or grass-covered land. Other states or federal areas may have similar laws.

Introduction

This machine is a ride-on, rotary-blade lawnmower intended to be used by professional, hired operators in commercial applications. It is primarily designed for cutting grass on well-maintained lawns in parks, golf courses, sports fields, and on commercial grounds. It is not designed for cutting brush, mowing grass and other growth alongside highways, or for agricultural uses.

Read this information carefully to learn how to operate and maintain your product properly and to avoid injury and product damage. You are responsible for operating the product properly and safely.

You may contact Toro directly at www.Toro.com for product and accessory information, help finding a dealer, or to register your product.

Whenever you need service, genuine Toro parts, or additional information, contact an Authorized Service Dealer or Toro Customer Service and have the model and serial numbers of your product ready. Figure 1 identifies the location of the model and serial numbers on the product. Write the numbers in the space provided.

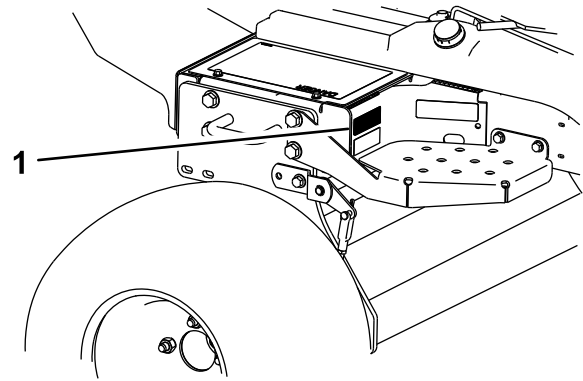

Figure 1

1. Model and serial number location

Model No. _____
Serial No. _____

This manual identifies potential hazards and has safety messages identified by the safety alert symbol (Figure 2), which signals a hazard that may cause serious injury or death if you do not follow the recommended precautions.



Figure 2

1. Safety alert symbol

This manual uses 2 other words to highlight information. **Important** calls attention to special mechanical information and **Note** emphasizes general information worthy of special attention.

Contents

Introduction	2	Brake Maintenance	40
Safety	4	Adjusting the Parking Brake	40
Safe Operating Practices	4	Belt Maintenance	40
Toro Mower Safety	6	Servicing the Engine Belts	40
Sound Power Level	7	Hydraulic System Maintenance	41
Sound Pressure Level	7	Changing the Hydraulic Filter	41
Vibration Level	7	Changing the Hydraulic Fluid	41
Safety and Instructional Decals	8	Checking the Hydraulic Lines and Hoses	42
Setup	12	Storage	43
1 Activating, Charging, and Connecting the Battery	12	Storing the Battery	43
2 Checking the Angle Indicator	14	Preparation for Seasonal Storage	43
3 Install CE Decals	14	Schematics	44
4 Installing the Hood Latch (CE Only)	14		
5 Adjusting the Lift Arms	15		
6 Rear Ballast	17		
Product Overview	17		
Controls	17		
Specifications	19		
Attachments/Accessories	19		
Operation	20		
Checking the Engine Oil Level	20		
Filling the Fuel Tank	21		
Checking the Cooling System	22		
Checking the Hydraulic System	23		
Checking the Tire Pressure	23		
Torquing the Wheel Nuts	24		
Starting and Stopping the Engine	24		
Checking the Interlock System	24		
Towing the Traction Unit	24		
Standard Control Module (SCM)	25		
Operating Tips	27		
Maintenance	29		
Recommended Maintenance Schedule(s)	29		
Daily Maintenance Checklist	30		
Service Interval Chart	31		
Pre-maintenance Procedures	31		
Removing the Hood	31		
Lubrication	32		
Greasing the Bearings And Bushings	32		
Engine Maintenance	35		
Servicing the Air Cleaner	35		
Replacing the Carbon Canister Air Filter	35		
Changing the Engine Oil and Filter	35		
Replacing the Spark Plugs	36		
Fuel System Maintenance	37		
Replacing the Fuel Pump Filter	37		
Servicing the Fuel Tank	37		
Inspecting the Fuel Lines and Connections	37		
Electrical System Maintenance	38		
Caring for the Battery	38		
Fuses	38		
Drive System Maintenance	39		
Adjusting the Traction Drive for Neutral	39		
Cooling System Maintenance	39		
Cleaning the Engine Cooling System	39		

Safety

This machine meets or exceeds CEN standard EN 836:1997 (when appropriate decals applied), and ANSI B71.4-2012 specifications in effect at the time of production when equipped with required weight as listed in Rear Ballast section.

Improper use or maintenance by the operator or owner can result in injury. To reduce the potential for injury, comply with these safety instructions and always pay attention to the safety alert symbol, which means Caution, Warning, or Danger—personal safety instruction. Failure to comply with the instruction may result in personal injury or death.

Safe Operating Practices

The following instructions are from the CEN standard EN 836:1997, ISO standard 5395:1990, and ANSI B71.4-2012.

Training

- Read the *Operator's Manual* and other training material carefully. Be familiar with the controls, safety signs, and the proper use of the equipment.
- If the operator or mechanic can not read the language of this manual, it is the owner's responsibility to explain this material to them.
- Never allow children or people unfamiliar with these instructions to use or service the mower. Local regulations may restrict the age of the operator.
- Never mow while people, especially children, or pets are nearby.
- Keep in mind that the operator or user is responsible for accidents or hazards occurring to other people or their property.
- Do not carry passengers.
- All drivers and mechanics should seek and obtain professional and practical instruction. The owner is responsible for training the users. Such instruction should emphasize the following:
 - The need for care and concentration when working with ride-on machines
 - Control of a ride-on machine sliding on a slope will not be regained by the application of the brake. The main reasons for loss of control are as follows:
 - ◇ Insufficient wheel grip
 - ◇ Being driven too fast
 - ◇ Inadequate braking
 - ◇ The type of machine is unsuitable for the task
 - ◇ Lack of awareness of the effect of ground conditions, especially slopes
 - ◇ Incorrect hitching and load distribution

Preparation

- While mowing, always wear substantial footwear, long trousers, hard hat, safety glasses, and hearing protection. Long hair, loose clothing, or jewelry may get tangled in moving parts. Do not operate the equipment when barefoot or wearing open sandals.
- Thoroughly inspect the area where the equipment is to be used and remove all objects which may be thrown by the machine.
- **Warning**—Fuel is highly flammable. Take the following precautions:
 - Store fuel in containers specifically designed for this purpose.
 - Refuel outdoors only and do not smoke while refueling.
 - Add fuel before starting the engine. Never remove the cap of the fuel tank or add fuel while the engine is running or when the engine is hot.
 - If fuel is spilled, do not attempt to start the engine but move the machine away from the area of spillage and avoid creating any source of ignition until fuel vapors have dissipated.
 - Replace all fuel tank and container caps securely.
- Replace faulty silencers/mufflers.
- Before using, always visually inspect to see that the blades, blade bolts, and cutting assembly are not worn or damaged. Replace worn or damaged blades and bolts in sets to preserve balance.
- On multi-bladed machines, take care as rotating one blade can cause other blades to rotate.
- Evaluate the terrain to determine what accessories and attachments are needed to properly and safely perform the job. Only use accessories and attachments approved by the manufacturer.
- Check that operator's presence controls, safety switches and shields are attached and functioning properly. Do not operate unless they are functioning properly.

Operation

- Do not operate the engine in a confined space where dangerous carbon monoxide fumes can collect.
- Mow only in daylight or in good artificial light.
- Before attempting to start the engine, disengage all blade attachment clutches, shift into neutral, and engage the parking brake. Only start the engine from the operator's position. Never remove the ROPS and always wear the seat belts during operation.
- Do not put hands or feet near or under rotating parts. Keep clear of the discharge opening at all times.
- Remember there is no such thing as a safe slope. Travel on grass slopes requires particular care. Do the following to guard against overturning:

- Do not stop or start suddenly when going up or downhill.
- Keep machine speeds low on slopes and during tight turns.
- Stay alert for humps and hollows and other hidden hazards.
- Never mow across the face of the slope, unless the mower is designed for this purpose.
- Stay alert for holes in the terrain and other hidden hazards.
- Watch out for traffic when crossing or near roadways.
- Stop the blades from rotating before crossing surfaces other than grass.
- When using any attachments, never direct discharge of material toward bystanders nor allow anyone near the machine while in operation.
- Never operate the machine with damaged guards, shields, or without safety protective devices in place. Be sure all interlocks are attached, adjusted properly, and functioning properly.
- Do not change the engine governor settings or overspeed the engine. Operating the engine at excessive speed may increase the hazard of personal injury.
- Do the following before leaving the operator's position:
 - Stop on level ground.
 - Disengage the power take-off and lower the attachments.
 - Change into neutral and set the parking brake.
 - Stop the engine and remove the key.
- Disengage the drive to attachments, stop the engine, and remove the ignition key in the following conditions:
 - Before making height adjustments, unless the adjustment can be made from the operator's position.
 - Before clearing blockages
 - Before checking, cleaning, or working on the mower
 - After striking a foreign object or if an abnormal vibration occurs (check immediately). Inspect the mower for damage and make repairs before restarting and operating the equipment. Torque all the spindle pulley nuts to 130 to 150 ft-lb (176 to 203 N-m).
- Disengage the drive to attachments when transporting or when the machine is not in use.
- Stop the engine and disengage the drive to attachments before the following:
 - Refueling
 - Making height adjustment, unless the adjustment can be made from the operator's position
- Reduce the throttle setting before stopping the engine and, if the engine is provided with a fuel shut-off valve, turn the fuel off at the conclusion of mowing.
- Never raise the cutting unit with the blades running.
- Keep hands and feet away from the cutting units.
- Look behind and down before backing up to be sure of a clear path.
- Slow down and use caution when making turns and crossing roads and sidewalks.
- Do not operate the mower under the influence of alcohol or drugs.
- Lightning can cause severe injury or death. If lightning is seen or thunder is heard in the area, do not operate the machine; seek shelter.
- Use care when loading or unloading the machine into a trailer or truck.
- The operator shall turn on flashing warning lights, if provided, whenever traveling on a public road, except where such use is prohibited by law.

Maintenance and Storage

- Keep all nuts, bolts and screws tight to be sure the equipment is in safe working condition.
- Never store the equipment with fuel in the tank inside a building where fumes may reach an open flame or spark.
- Allow the engine to cool before storing in any enclosure.
- To reduce the fire hazard, keep the engine, silencer/muffler, battery compartment fuel storage area, cutting units and drives free of grass, leaves, or excessive grease. Clean up oil or fuel spillage.
- Replace worn or damaged parts for safety.
- If the fuel tank has to be drained, do this outdoors.
- On multi-bladed machines, take care as rotating one blade can cause other blades to rotate.
- When machine is to be parked, stored, or left unattended, lower the cutting units unless a positive mechanical lock is provided.
- Disengage drives, lower the cutting units, set parking brake, stop engine and remove key. Wait for all movement to stop before adjusting, cleaning or repairing.
- Do not store fuel near flames.
- Park the machine on level ground. Never allow untrained personnel to service machine.
- Use jack stands to support components when required.
- Carefully release pressure from components with stored energy.
- Disconnect battery before making any repairs. Disconnect the negative terminal first and the positive last. Reconnect positive first and negative last.
- Use care when checking the blades. Wrap the blades or wear gloves, and use caution when servicing them. Only replace blades. Never straighten or weld them.
- Keep hands and feet away from moving parts. If possible, do not make adjustments with the engine running.
- Charge batteries in an open well ventilated area, away from spark and flames. Unplug charger before connecting

or disconnecting from battery. Wear protective clothing and use insulated tools.

Toro Mower Safety

The following list contains safety information specific to Toro products or other safety information that you must know that is not included in the CEN, ISO, or ANSI standards.

This product is capable of amputating hands and feet and throwing objects. Always follow all safety instructions to avoid serious injury or death.

Use of this product for purposes other than its intended use could prove dangerous to user and bystanders.

▲ WARNING

Engine exhaust contains carbon monoxide, which is an odorless, deadly poison that can kill you. Do not run engine indoors or in an enclosed area.

Preparation

Be sure to establish your own special procedures and work rules for unusual operating conditions (e.g., slopes too steep for operation). **Survey the complete mowing site to determine which hills can be safely operated on.** When performing this site survey, always use common sense and take into consideration the turf condition and the rollover risk. To determine which hills or slopes may be safely operated on, use the inclinometer provided with each machine. To perform a site survey, follow the procedure outlined in the Operation section of the this manual. **The maximum side hill angle is detailed on the slope decal affixed near the angle indicator.**

Training

The operator must be skilled and trained in how to drive on hillsides. Failure to use caution on slopes or hills may cause the vehicle to tip or roll, possibly resulting in personal injury or death.

Operation

- Know how to stop the machine and engine quickly.
- Do not operate the machine while wearing tennis shoes or sneakers.
- Wearing safety shoes and long pants is advisable and required by some local ordinances and insurance regulations.
- Keep hands, feet, and clothing away from moving parts and the mower discharge area.
- Fill the fuel tank until level is 1/4 to 1/2 inch (6 to 13 mm) below the bottom of the filler neck. Do not overfill.
- Check the safety interlock switches daily for proper operation. If a switch should fail, replace the switch before operating the machine.

- When starting the engine, engage the parking brake, put the traction pedal in neutral, and disengage the blade drive. After the engine starts, release the parking brake and keep your foot off of the traction pedal. The machine must not move. If movement is evident, refer to the Maintenance section of this manual to adjust the traction drive.
- Use extreme caution when operating close to sand traps, ditches, creeks, steep hillsides, or other hazards.
- Reduce speed when making sharp turns.
- Do not turn on hills.
- Do not operate on a side hill that is too steep. A rollover may occur before losing traction.
- The slope angle at which the machine will tip is dependent on many factors. Among these are mowing conditions such as wet or undulating terrain, speed (especially in turns), position of the cutting units (with the Sidewinder), tire pressure, and operator experience. At side hill angles of 20 degrees or less, the risk of a rollover is low. As the slope angle increases to a recommended maximum limit of 25 degrees, the risk of a rollover increases to a moderate level. **Do not exceed a 25 degree side hill slope angle because the risk of a rollover and serious injury or death is very high.**
- For steering control, lower the cutting units when going down slopes.
- Avoid sudden stops and starts.
- Use the reverse pedal for braking.
- Watch for traffic when near or crossing roads. Always yield the right-of-way.
- Raise the cutting units when driving from one work area to another.
- Do not touch the engine, muffler, exhaust pipe, or hydraulic tank while the engine is running or soon after it has stopped because these areas could be hot enough to cause burns.
- This machine is not designed or equipped for on-road use and is a slow-moving vehicle. If you must cross or travel on a public road, you should be aware of and comply with local regulations, such as required lights, slow moving vehicle signs, and reflectors.

Maintenance and Storage

- Before servicing or making adjustments, stop the engine and remove the ignition key.
- Ensure that the entire machine is properly maintained and in good operating condition. Frequently check all nuts, bolts, screws, and hydraulic fittings.
- Make sure all hydraulic line connectors are tight and all hydraulic hoses and lines are in good condition before applying pressure to the system.
- Keep your body and hands away from pin hole leaks or nozzles that eject hydraulic fluid under high pressure.

Use paper or cardboard, not your hands, to search for leaks. Hydraulic fluid escaping under pressure can have sufficient force to penetrate the skin and cause serious injury. If fluid is injected into the skin it must be surgically removed within a few hours by a doctor familiar with this form of injury or gangrene may result.

- Before disconnecting or performing any work on the hydraulic system, all pressure in the system must be relieved by stopping the engine and lowering the cutting units to the ground.
- If the engine must be running to perform a maintenance adjustment, keep hands, feet, clothing, and any parts of the body away from the cutting units, attachments, and any moving parts. Keep everyone away.
- Do not overspeed the engine by changing governor settings. To ensure safety and accuracy, have an Authorized Toro Distributor check the maximum engine speed with a tachometer.
- The engine must be shut off before checking the oil or adding oil to the crankcase.
- If major repairs are ever needed or if assistance is desired, contact an Authorized Toro Distributor.
- To ensure optimum performance and continued safety certification of the machine, use only genuine Toro replacement parts and accessories. Replacement parts and accessories made by other manufacturers could be dangerous, and such use could void the product warranty.

Sound Power Level

This unit has a guaranteed sound power level of 105 dBA, which includes an Uncertainty Value (K) of 1 dBA.

Sound power level was determined according to the procedures outlined in ISO 11094.

Sound Pressure Level

This unit has a sound pressure level at the operator's ear of 92 dBA, which includes an Uncertainty Value (K) of 1 dBA.

Sound pressure level was determined according to the procedures outlined in EN 836.

Vibration Level

Hand-Arm

Measured vibration level for right hand = 0.5 m/s²

Measured vibration level for left hand = 0.7 m/s²

Uncertainty Value (K) = 0.5 m/s²

Measured values were determined according to the procedures outlined in EN 836.

Whole Body

Measured vibration level = 0.44 m/s²

Uncertainty Value (K) = 0.5 m/s²

Measured values were determined according to the procedures outlined in EN 836.

Safety and Instructional Decals



Safety decals and instructions are easily visible to the operator and are located near any area of potential danger. Replace any decal that is damaged or lost.

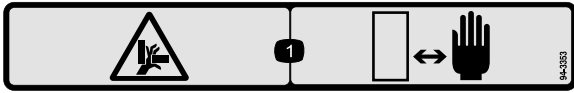

94-3353

1. Crushing hazard of hand—keep your hands a safe distance away.



107-7801

(CE only) This safety decal includes a slope warning required on the machine for compliance to the European Lawn Mower Safety Standard EN836:1997. The conservative maximum slope angles indicated for operation of this machine are prescribed by and required by this standard.

1. Tipping hazard—do not drive on slopes greater than 15 degrees.



100-4837



93-7276

1. Explosion hazard—wear eye protection.
2. Caustic liquid/chemical burn hazard—to perform first aid, flush with water.
3. Fire hazard—no fire, open flames, or smoking.
4. Poison hazard—keep children a safe distance from the battery.

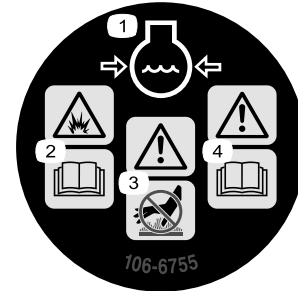

106-6755

1. Engine coolant under pressure.
2. Explosion hazard—read the *Operator's Manual*.
3. Warning—do not touch the hot surface.
4. Warning—read the *Operator's Manual*.

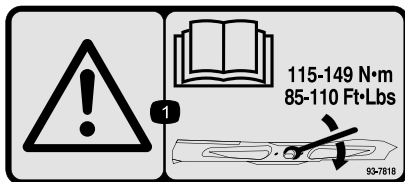

93-7818

1. Warning—read the *Operator's Manual* for instructions on torquing the blade bolt/nut to 85-110 ft-lb (115-149 N-m).

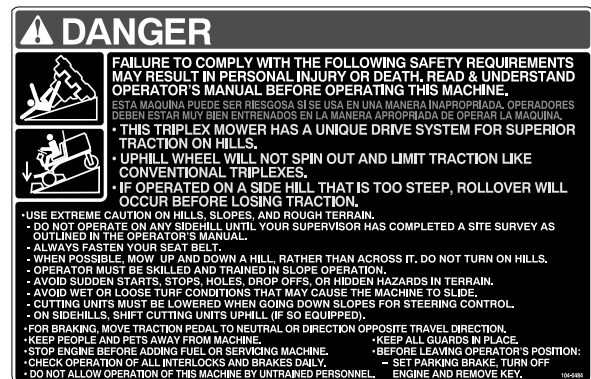

104-0484

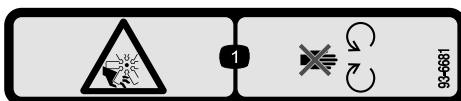

93-6681

1. Cutting/dismemberment—hazard, fan—stay away from moving parts.

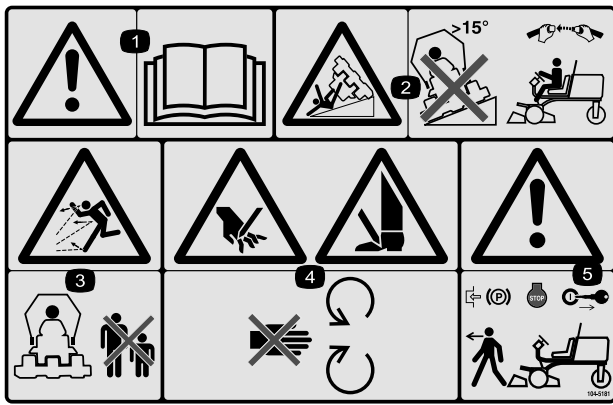

104-5181
CE only

1. Warning—read the *Operator's Manual*.
2. Tipping hazard—do not drive on slopes greater than 15 degrees and, if the roll bar is installed, wear the seat belt.
3. Thrown object hazard—keep bystanders a safe distance from the machine.
4. Cutting hazard of hand or foot—stay away from moving parts.
5. Warning—lock the parking brake, stop the engine, and remove the ignition key before leaving the machine.



Battery Symbols

Some or all of these symbols are on your battery

1. Explosion hazard
2. No fire, open flame, or smoking.
3. Caustic liquid/chemical burn hazard
4. Wear eye protection
5. Read the *Operator's Manual*.
6. Keep bystanders a safe distance from the battery.
7. Wear eye protection; explosive gases can cause blindness and other injuries
8. Battery acid can cause blindness or severe burns.
9. Flush eyes immediately with water and get medical help fast.
10. Contains lead; do not discard.

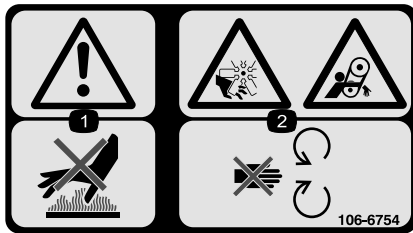

106-6754

1. Warning—do not touch the hot surface.
2. Cutting/dismemberment hazard, fan and entanglement hazard, belt—stay away from moving parts.

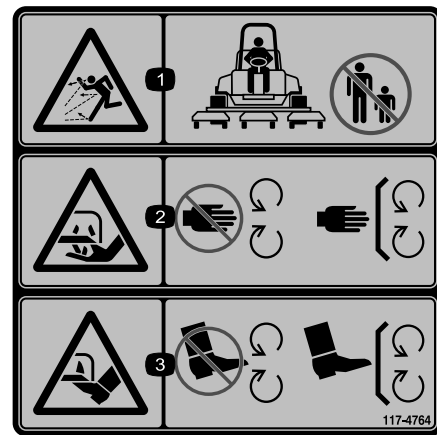

117-4764

1. Thrown object hazard—keep bystanders a safe distance from the machine.
2. Cutting hazard of hand, mower blade—stay away from moving parts, keep all guards and shields in place.
3. Cutting hazard of foot, mower blade—stay away from moving parts, keep all guards and shields in place.

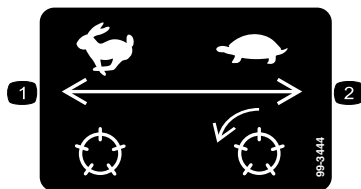

99-3444

1. Transport speed—fast
2. Mowing speed—slow

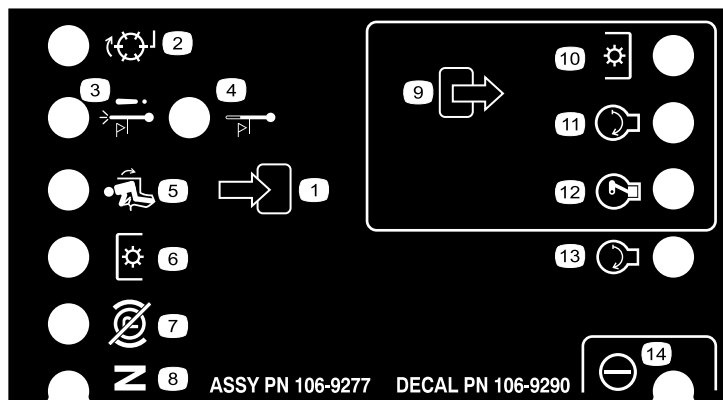

106-9290

- | | | | |
|------------------------------|-------------------------|---------------------------|-----------|
| 1. Inputs | 5. In seat | 9. Outputs | 13. Start |
| 2. Not active | 6. Power Take-off (PTO) | 10. Power Take Off (PTO) | 14. Power |
| 3. High temperature shutdown | 7. Parking brake Off | 11. Start | |
| 4. High temperature warning | 8. Neutral | 12. Energize to Run (ETR) | |

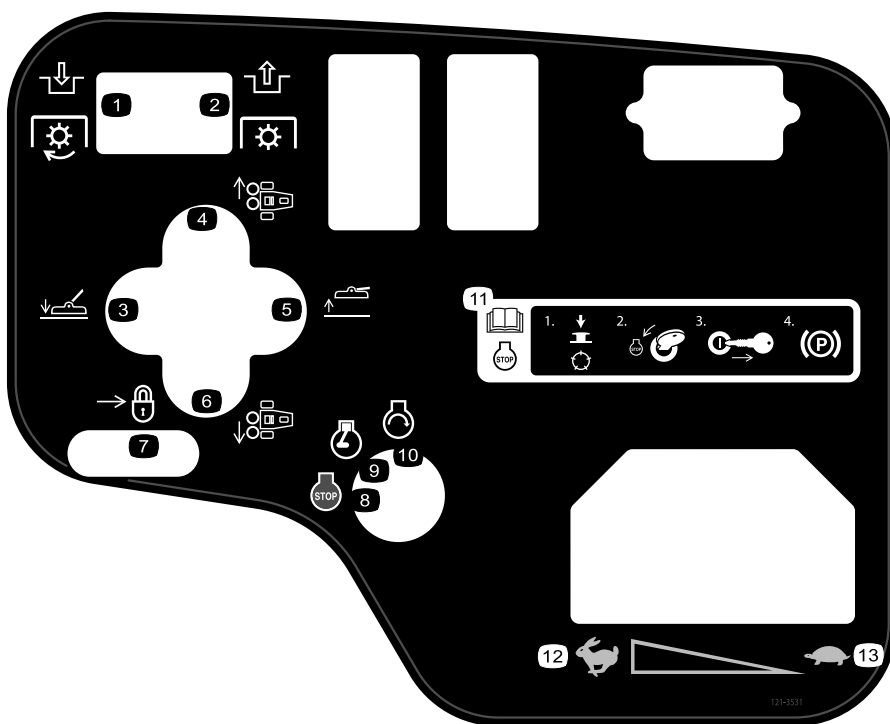

121-3531

- | | | |
|-----------------------|------------------|--|
| 1. Engage PTO | 6. Move left | 11. Read the <i>Operator's Manual</i> for information on stopping the engine—
1) Disengage the reel; 2) Move the key to the engine stop position; 3) Remove the key from the ignition; 4) Engage the parking brake. |
| 2. Disengage PTO | 7. Lock | 12. Fast |
| 3. Lower cutting unit | 8. Engine—stop | 13. Slow |
| 4. Move right | 9. Engine—run | |
| 5. Raise cutting unit | 10. Engine—start | |

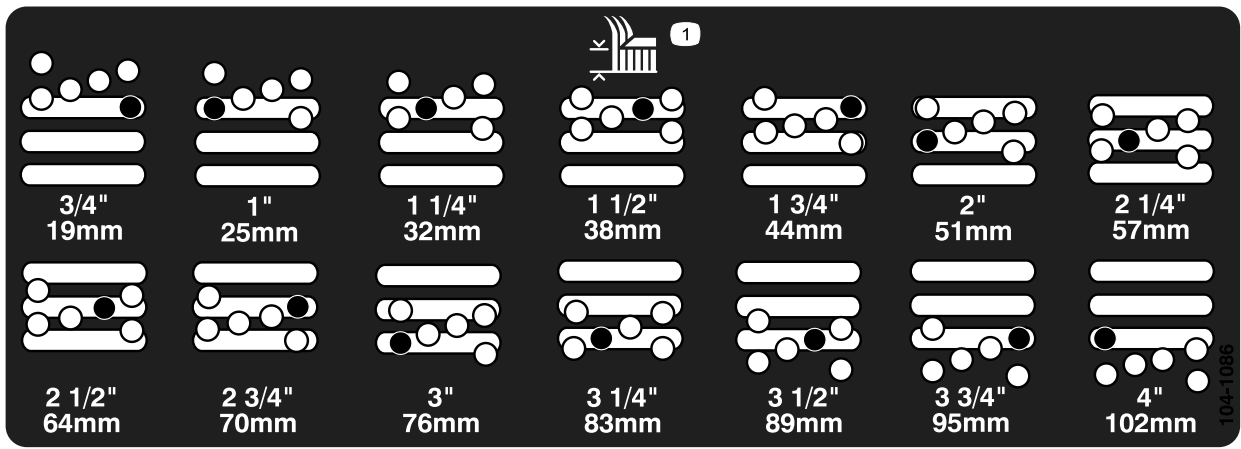

104-1086

1. Height of cut

GROUNDMASTER 3500-G

QUICK REFERENCE AID

CHECK/SERVICE (DAILY)

1. OIL LEVEL, ENGINE
2. ENGINE OIL DRAIN (14mm SOCKET)
3. OIL LEVEL HYDRAULIC TANK
4. COOLANT LEVEL, RADIATOR
5. AIR CLEANER

6. RADIATOR SCREEN
7. PARKING BRAKE
8. TIRE PRESSURE (14-18 psi)
9. BATTERY
10. BELTS (FAN, ALTERNATOR, HYDRAULIC PUMP)

GREASING - SEE OPERATOR'S MANUAL

FLUID SPECIFICATIONS / CHANGE INTERVALS

SEE OPERATOR'S MANUAL FOR INITIAL CHANGES.	FLUID TYPE	CAPACITY	CHANGE INTERVAL		FILTER PART NO.
			FLUID	FILTER	
A. ENGINE OIL	SAE 10W-30	3.6 QTS.*	200 HRS.	200 HRS.	115-8189
B. HYD. CIRCUIT OIL	ISO VG 46/68	6 GAL.*	400 HRS.	200 HRS.	86-3010
C. AIR CLEANER				200 HRS.	108-3811
D. FUEL TANK	UNLEADED GASOLINE	10 GALS.	DRAIN AND FLUSH, 2 YRS.		
E. COOLANT	50/50 ETHYLENE GLYCOL/WATER	7 QTS.	DRAIN AND FLUSH, 2 YRS.		

* INCLUDING FILTER

121-3533

121-3533

1. Read the *Operator's Manual* for information on maintenance.

Setup

Loose Parts

Use the chart below to verify that all parts have been shipped.

Procedure	Description	Qty.	Use
2	Inclinometer	1	Check the angle indicator
3	Warning decal (104–5181)	1	Install CE decals, if required.
4	Lock bracket Rivet Washer Screw, 1/4 x 2 inches Locknut, 1/4 inch	1 2 1 1 1	Install the Hood Latch (CE).
5	No parts required	–	Adjust the lift arms.
6	No parts required	–	Rear ballast.

Media and Additional Parts

Description	Qty.	Use
Decal, CE	6	Affix to the machine over corresponding English decals for European compliance.
Ignition keys	2	Start the engine.
Operator's Manual Engine Operator's Manual	1 1	Read before operating the machine.
Parts Catalog	1	Use to look up and order parts.
Operator video	1	View before operating the machine.
Certificate of compliance	1	Ensure CE compliance.

Note: Determine the left and right sides of the machine from the normal operating position.

1

Activating, Charging, and Connecting the Battery

No Parts Required

Procedure

WARNING

CALIFORNIA Proposition 65 Warning

Battery posts, terminals, and related accessories contain lead and lead compounds, chemicals known to the State of California to cause cancer and reproductive harm.
Wash hands after handling.

Note: If the battery is not filled with electrolyte or activated, bulk electrolyte with 1.260 specific gravity must be purchased from a local battery supply outlet and added to the battery.

⚠ DANGER

Battery electrolyte contains sulfuric acid which is a deadly poison and causes severe burns.

- Do not drink electrolyte and avoid contact with skin, eyes, or clothing. Wear safety glasses to shield your eyes and rubber gloves to protect your hands.
- Fill the battery where clean water is always available for flushing the skin.

1. Open the hood.
2. Remove the battery cover (Figure 3).

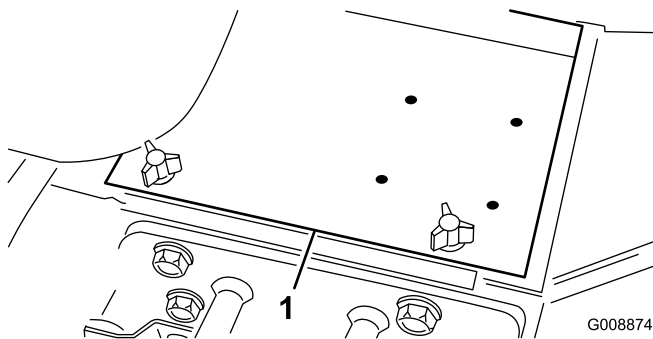

Figure 3

1. Battery cover

3. Remove the filler caps from the battery and slowly fill each cell until electrolyte is just above the plates.
4. Install the filler caps and connect a 3 to 4 amp battery charger to the battery posts. Charge the battery at a rate of 3 to 4 amperes for 4 to 8 hours.

⚠ WARNING

Charging the battery produces gasses that can explode.

- Keep sparks and flames away from battery.
 - Never smoke near the battery.
5. When the battery is charged, disconnect the charger from the electrical outlet and battery posts.
 6. Remove the filler caps. Slowly add electrolyte to each cell until the level is up to the fill ring. Install the filler caps.
- Important:** Do not overfill the battery. Electrolyte will overflow onto other parts of the machine and severe corrosion and deterioration will result.
7. Install the positive cable (red) to the positive (+) terminal and the negative cable (black) to the negative (-) terminal of the battery and secure them with bolts and nuts (Figure 4). Make sure that the positive (+) terminal is all of the way onto the post and the cable is positioned snug to the battery. The cable must not contact the battery cover.

⚠ WARNING

Incorrect battery cable routing could damage the tractor and cables causing sparks. Sparks can cause the battery gasses to explode, resulting in personal injury.

- Always disconnect the negative (black) battery cable before disconnecting the positive (red) cable.
- Always connect the positive (red) battery cable before connecting the negative (black) cable.

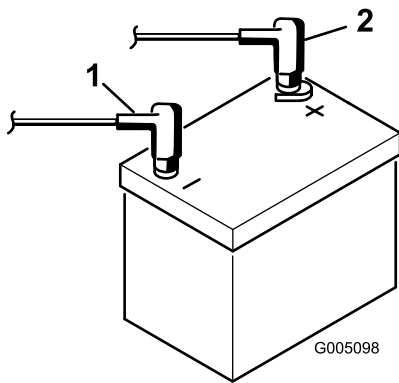

Figure 4

1. Positive (+) battery cable
2. Negative (-) battery cable

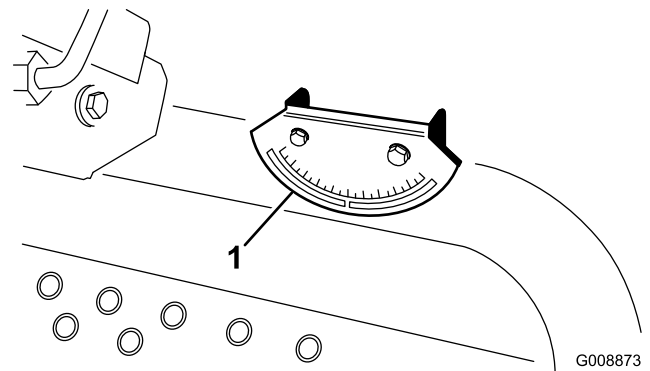

Figure 5

1. Angle indicator

Important: If the battery is ever removed, make sure that the battery clamp bolts are installed with the bolt heads positioned on the bottom side and the nuts on the top side. If the clamp bolts are reversed, they may interfere with the hydraulic tubes when shifting the cutting units.

8. Coat both battery connections with Grafo 112X (skin over) grease, Toro Part No. 505-47, petroleum jelly, or light grease to prevent corrosion.
9. Slide the rubber boot over the positive terminal to prevent a possible short from occurring.
10. Install the battery cover.

3. If the inclinometer does not read zero degrees, move the machine to a location where a zero degree reading is obtained. The angle indicator, mounted on the machine, should now read zero degrees as well.
4. If the angle indicator does not read zero degrees, loosen the two screws and nuts securing the angle indicator to the mounting bracket, adjust the indicator to obtain a zero degree reading, and tighten the bolts.

3

Install CE Decals

Parts needed for this procedure:

1	Warning decal (104-5181)
---	--------------------------

Procedure

If this machine will be used for CE, affix the warning decal 104-5181 over English warning decal 104-0484.

2

Checking the Angle Indicator

Parts needed for this procedure:

1	Inclinometer
---	--------------

Procedure

⚠ DANGER

To reduce risk of injury or death due to rollover, do not operate the machine on side hills steeper than 25°.

1. Park the machine on a flat, level surface.
2. Verify that the machine is level by placing a hand held inclinometer (supplied with the machine) on the frame cross rail, by the fuel tank (Figure 5). The inclinometer should read zero degrees when viewed from the operator's position.

4

Installing the Hood Latch (CE Only)

Parts needed for this procedure:

1	Lock bracket
2	Rivet
1	Washer
1	Screw, 1/4 x 2 inches
1	Locknut, 1/4 inch

Procedure

1. Unhook the hood latch from the hood latch bracket.
2. Remove the (2) rivets securing the hood latch bracket to the hood (Figure 6). Remove the hood latch bracket from the hood.

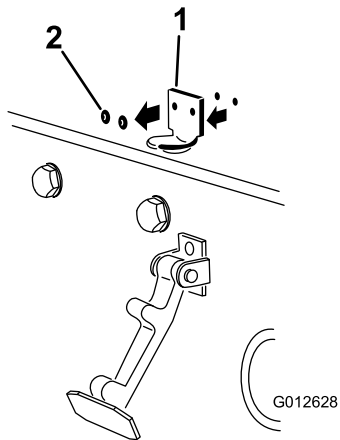

Figure 6

1. Hood latch bracket
2. Rivets

3. While aligning the mounting holes, position the CE lock bracket and the hood latch bracket onto the hood. The lock bracket must be against the hood (Figure 7). Do not remove bolt and nut assembly from the lock bracket arm.

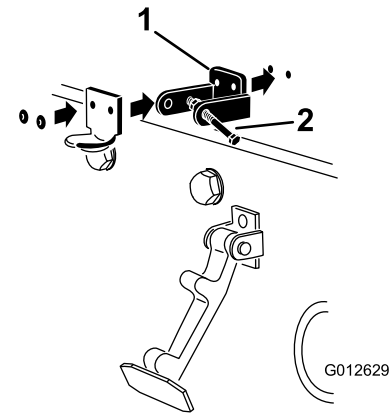

Figure 7

1. CE lock bracket
2. Bolt and nut assembly

4. Align the washers with the holes on the inside of the hood.
5. Rivet the brackets and the washers to the hood (Figure 7).
6. Hook the latch onto the hood latch bracket (Figure 8).

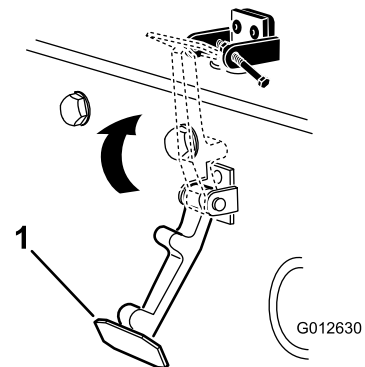

Figure 8

1. Hood latch

7. Screw the bolt into the other arm of hood lock bracket to lock the latch in position (Figure 9). Tighten bolt securely but do not tighten nut.

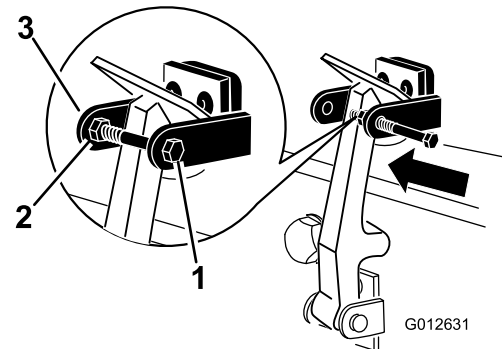

Figure 9

1. Bolt
2. Nut
3. Arm of hood lock bracket

5

Adjusting the Lift Arms

No Parts Required

Procedure

1. Start the engine, raise the cutting units, and check to ensure that the clearance between each lift arm and the floor plate bracket is 0.18 to 0.32 inches (5 to 8 mm) (Figure 10).

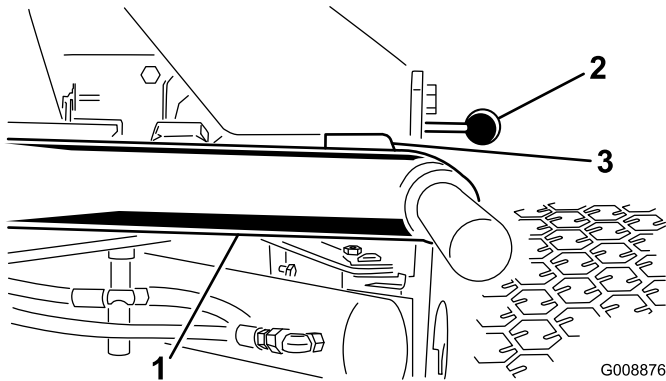

Figure 10
cutting units removed for clarity

1. Lift arm
2. Floor plate bracket
3. Clearance

If the clearance is not in this range, adjust it as follows:

- A. Back off the stop bolts (Figure 11).

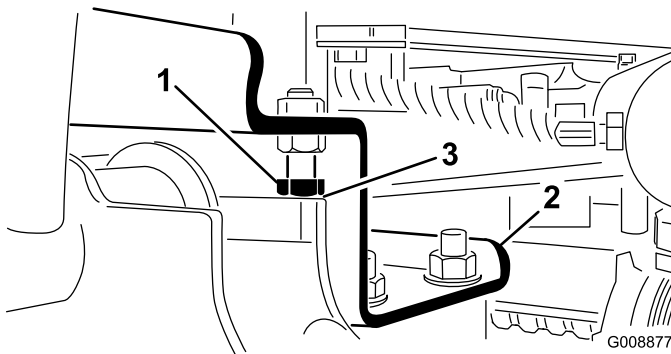

Figure 11

1. Stop bolt
2. Lift arm
3. Clearance

- B. Back off the jam nut on the cylinder (Figure 12).

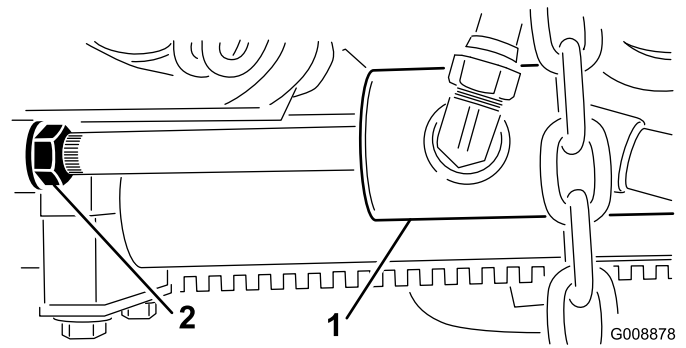

Figure 12

1. Front cylinder
2. Jam nut

- C. Remove the pin from the rod end and rotate the clevis.
- D. Install the pin and check the clearance. Repeat the procedure if required.
- E. Tighten the clevis jam nut.

2. Check to make sure that the clearance between each lift arm and stop bolt is 0.005 to 0.040 inches (0.13 to 1.02 mm) (Figure 11). If the clearance is not in this range, adjust the stop bolts to attain clearance.
3. Start the engine, raise the cutting units, and check to make sure that the clearance between the wear strap on the top of the rear cutting unit wear bar and the bumper strap is 0.02 to 0.10 inches (0.51 to 2.54 mm) (Figure 13).

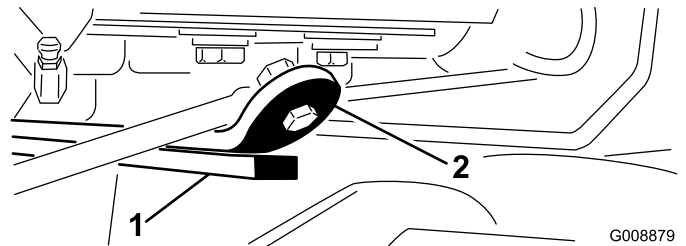

Figure 13

1. Wear bar
2. Bumper strap

If the clearance is not in this range, adjust the rear cylinder as follows:

Note: If the rear lift arm clunks during transport, clearance can be reduced.

- A. Lower the cutting units and back off the jam nut on the cylinder (Figure 14).

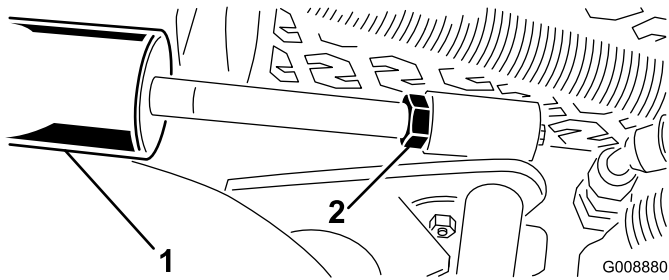

Figure 14

- 1. Rear cylinder
- 2. Adjusting nut

- B. Grasp the cylinder rod close to the nut with a pliers and rag and rotate the rod.
- C. Raise the cutting units and check the clearance. Repeat the procedure if required.
- D. Tighten the clevis jam nut.

Important: Lack of clearance at the front stops or rear wear bar could damage the lift arms.

6

Rear Ballast

No Parts Required

Procedure

The machine conforms to CEN standard EN 836:1997 and ANSI standard B71.4-2012 standard when 50 lbs. (22.6 kg) of calcium chloride ballast is added to the rear wheels.

Important: If a puncture occurs in a tire with calcium chloride, remove the machine from the turf as quickly as possible. To prevent possible damage to the turf, immediately soak the affected area with water.

Product Overview

Controls

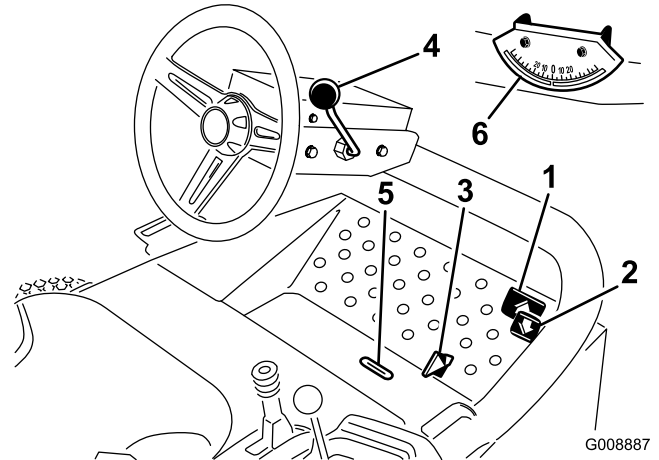

Figure 15

- 1. Forward traction pedal
- 2. Reverse traction pedal
- 3. Mow/transport slide
- 4. Tilt steering lever
- 5. Indicator slot
- 6. Angle indicator

Traction Pedals

Press the traction forward pedal (Figure 15) to move forward. Press traction reverse pedal (Figure 15) to move backward or to assist in stopping when moving forward. Also, allow the pedal to move or move it to the neutral position to stop the machine.

Mow/Transport Slide

Using your heel, move the mow/transport slide (Figure 15) to the left to transport and to the right to mow. **The cutting units will only operate in the mow position.**

Important: The mow speed is set at the factory to 6 MPH (9.7 km/h). It can be increased or decreased by adjusting the speed stop screw (Figure 16).

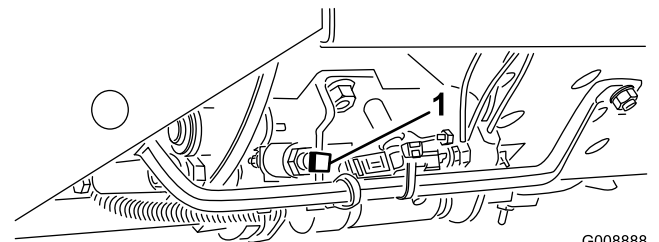

Figure 16

- 1. Speed stop screw

Tilt Steering Lever

Pull the tilt steering lever (Figure 15) back to tilt the steering wheel to the desired position. Then push the lever forward to tighten.

Indicator Slot

The slot in the operator platform (Figure 15) indicates when the cutting units are in the center position.

Angle Indicator

The angle indicator (Figure 15) indicates the side hill angle of the machine in degrees.

Ignition Switch

The ignition switch (Figure 17), used to start and stop the engine, has three positions: Off, On, and Start. Rotate the key to the Start position to engage the starter motor. Release the key when the engine starts. The key will move automatically to the On position. To shut the engine off, rotate the key to the Off position. Remove the key from the switch to prevent accidental starting.

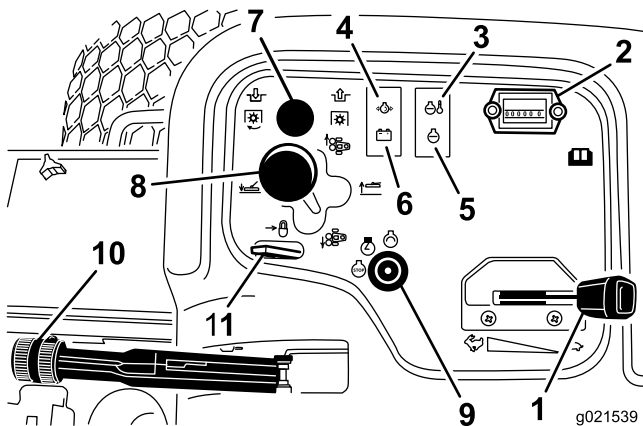

Figure 17

- | | |
|-----------------------|-----------------------------|
| 1. Throttle | 7. PTO switch |
| 2. Hour meter | 8. Cutting unit shift lever |
| 3. Temperature light | 9. Ignition switch |
| 4. Oil pressure light | 10. Parking brake |
| 5. Check engine light | 11. Lift lever lock |
| 6. Alternator light | |

Throttle

Move the throttle (Figure 17) forward to increase the engine speed and rearward to decrease the engine speed.

PTO Switch

The PTO switch (Figure 17) has two positions: Out (start) and In (stop). Pull the PTO switch out to engage the cutting unit blades. Push in the switch to disengage the cutting unit blades.

Hour Meter

The hour meter (Figure 17) indicates the total hours of machine operation. The hour meter starts to function whenever the key switch is On.

Cutting Unit Shift Lever

To lower the cutting units to the ground, move the cutting unit shift lever (Figure 17) forward. The cutting units will not drop unless the engine is running. To raise the cutting units, pull the shift lever rearward to the Raise position.

Move the lever to the right or left to move the cutting units in the same direction. This should only be done when the cutting units are raised or if they are on the ground and the machine is moving.

Note: The lever does not have to be held in the forward position while the cutting units are lowered.

▲ DANGER

Shifting the cutting units downhill decreases machine stability. This could cause a rollover, which may result in personal injury or death.

Shift the cutting units uphill while on a side hill.

Engine Coolant Temperature Warning Light

The temperature warning light (Figure 17) glows if the engine coolant temperature is high. If the traction unit is not stopped and the coolant temperature rises another 10° F, the engine will kill.

Oil Pressure Warning Light

The oil pressure warning light (Figure 17) glows if the engine oil pressure drops below a safe level.

Alternator Light

The alternator light (Figure 17) should be off when the engine is running. If it is on, the charging system should be checked and repaired as necessary.

Check Engine Light

The check engine light (Figure 17) should be off when the engine is running. If it is on, refer to the Service Manual.

Parking Brake

Whenever the engine is shut off, engage the parking brake (Figure 17) to prevent accidental movement of the machine. To engage the parking brake, pull up on the lever. The engine will stop if you press the traction pedal with the parking brake engaged.

Lift Lever Lock

Move the lift lever lock (Figure 17) rearward to prevent the cutting units from dropping.

Fuel Gauge

The fuel gauge (Figure 18) registers the amount of fuel in the tank.

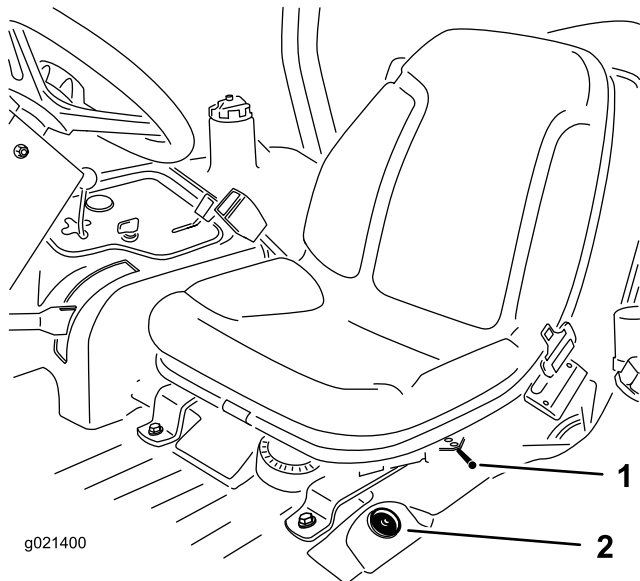

Figure 18

1. Fore and aft lever
2. Fuel gauge

Fore and Aft Seat Adjustments

Move the lever (Figure 18) on the side of the seat outward, slide the seat to the desired position, and release the lever to lock the seat into position.

Specifications

Note: Specifications and design are subject to change without notice.

Overall Width	71.8 inches (182 cm)
Width of Cut	68 inches (173 cm)
Length	116 inches (295 cm)
Height to top of ROPS	70.8 inches (180 cm)
Wheel Base	58.5 inches (149 cm)
Track Width	57 inches (145 cm)
Ground Clearance	6 inches (15.3 cm)
Weight with cutting units	2,124 lb (963 kg)

Attachments/Accessories

A selection of Toro approved attachments and accessories is available for use with the machine to enhance and expand its capabilities. Contact your Authorized Service Dealer or Distributor or go to www.Toro.com for a list of all approved attachments and accessories.

Operation

Note: Determine the left and right sides of the machine from the normal operating position.

Checking the Engine Oil Level

Service Interval: Before each use or daily

The engine is shipped with oil in the crankcase; however, the oil level must be checked before and after the engine is first started.

Crankcase capacity is approximately 3.5 qt (3.3 l) with the filter.

Note: Toro Premium Engine oil is available from your distributor in either 15W-40 or 10W-30 viscosity. See the parts catalog for part numbers.

Note: The best time to check the engine oil is when the engine is cool before it has been started for the day. If it has already been run, allow the oil to drain back down to the sump for at least 10 minutes before checking. If the oil level is at or below the “add” mark on the dipstick, add oil to bring the oil level to the “full” mark. **DO NOT OVERFILL.** If the oil level is between the “full” and “add” marks, no oil addition is required.

The engine uses any high-quality 10W-30 detergent oil having the American Petroleum Institute (API) service classification SJ, SK, SL, SM, or higher. Choose a viscosity according to the table in Figure 19.

USE THESE SAE VISCOSITY OILS

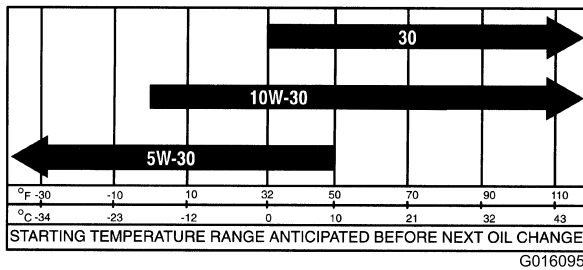

Figure 19

1. Position the machine on a level surface and open the hood.
2. Remove the dipstick (Figure 20) and wipe it with a clean rag. Insert the dipstick into the tube and make sure it is seated fully. Remove dipstick and check the level of the oil.

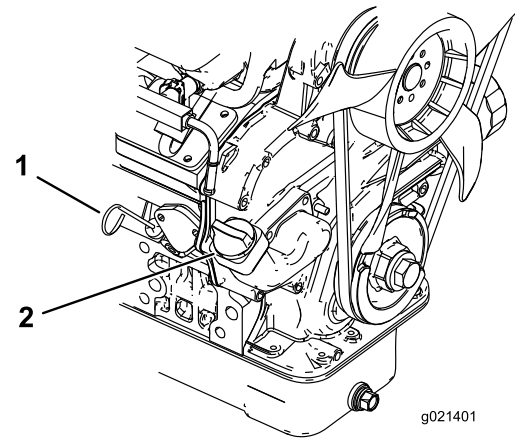

Figure 20

1. Dipstick
2. Filler cap

3. If the oil level is low, remove the filler cap (Figure 20) and add enough oil to raise the level to the Full mark on the dipstick.

Note: When adding oil, remove dipstick to allow proper venting. Pour oil slowly and check the level often during this process. Do not overfill.

Important: When adding engine oil or filling oil, there must be clearance between the oil fill device and the oil fill hole in the valve cover as shown in Figure 21. This clearance is necessary to permit venting when filling, which prevents oil from overrunning into the breather.

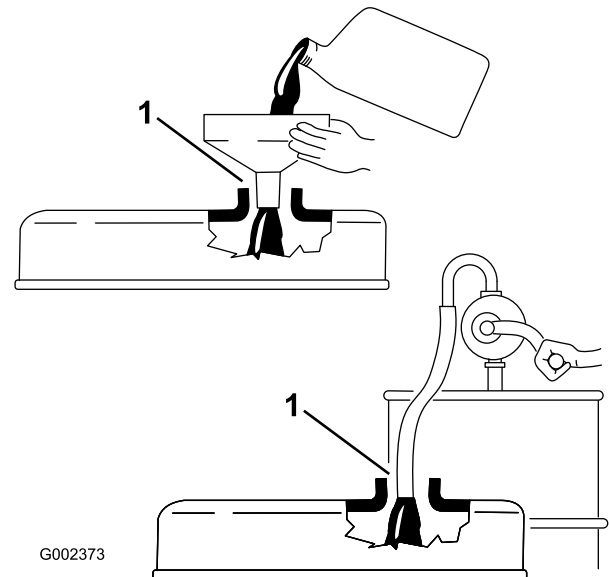

Figure 21

1. Note clearance
4. Install the dipstick firmly in place.
5. Install the oil fill cap and close the hood.

Filling the Fuel Tank

The Toro® Company strongly recommends the use of fresh, clean, unleaded regular grade gasoline in Toro gasoline powered products. Unleaded gasoline burns cleaner, extends engine life, and promotes good starting by reducing the build-up of combustion chamber deposits. Use a minimum octane rating of 87.

The fuel tank capacity is approximately 10 gallons (38 liters).

Note: Never use methanol, leaded gasoline, gasoline containing methanol, gasoline containing more than 10% ethanol, gasoline additives, or white gas because engine fuel system damage could result.

1. Clean the area around the fuel tank cap (Figure 22).
2. Remove the fuel tank cap.
3. Fill the tank to the bottom of the filler neck. **Do not overfill.** Install the cap.
4. To prevent a fire hazard, wipe up any fuel that may have spilled.

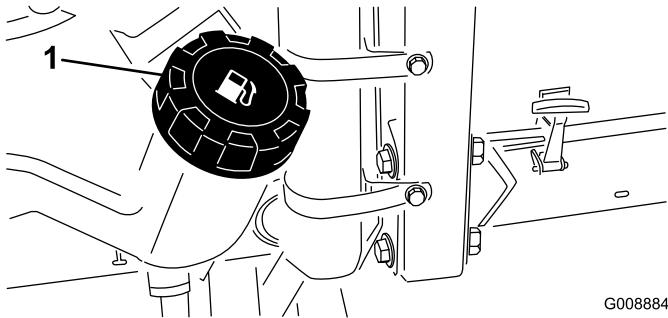

Figure 22

G008884

1. Fuel tank cap

⚠ DANGER

In certain conditions, gasoline is extremely flammable and highly explosive. A fire or explosion from gasoline can burn you and others and can damage property.

- Before removing the fuel tank cap, make sure the vehicle is positioned on a level surface. Open fuel tank cap slowly.
- Fill the fuel tank outdoors, in an open area, when the engine is cold. Wipe up any gasoline that spills.
- Never fill the fuel tank inside an enclosed trailer.
- Do not fill the fuel tank completely full. Add gasoline to the fuel tank until the level is 1/4 to 1/2 inch (6 to 13 mm) below the bottom of the filler neck. This empty space in the tank allows gasoline to expand.
- Never smoke when handling gasoline, and stay away from an open flame or where gasoline fumes may be ignited by a spark.
- Store gasoline in an approved container and keep it out of the reach of children. Never buy more than a 30-day supply of gasoline.
- Do not operate without entire exhaust system in place and in proper working condition.

⚠ DANGER

In certain conditions during fueling, static electricity can be released causing a spark which can ignite the gasoline vapors. A fire or explosion from gasoline can burn you and others and can damage property.

- Always place gasoline containers on the ground away from your vehicle before filling.
- Do not fill gasoline containers inside a vehicle or on a truck or trailer bed because interior carpets or plastic truck bed liners may insulate the container and slow the loss of any static charge.
- When practical, remove gas-powered equipment from the truck or trailer and refuel the equipment with its wheels on the ground.
- If this is not possible, then refuel such equipment on a truck or trailer from a portable container, rather than from a gasoline dispenser nozzle.
- If a gasoline dispenser nozzle must be used, keep the nozzle in contact with the rim of the fuel tank or container opening at all times until fueling is complete.

Checking the Cooling System

Service Interval: Before each use or daily

The capacity of the cooling system is approximately 6 qt. (5.7 liters).

Clean debris off of the radiator/oil cooler daily (Figure 23). Clean the radiator/oil hourly if conditions are extremely dusty and dirty; refer to Cleaning the Engine Cooling System.

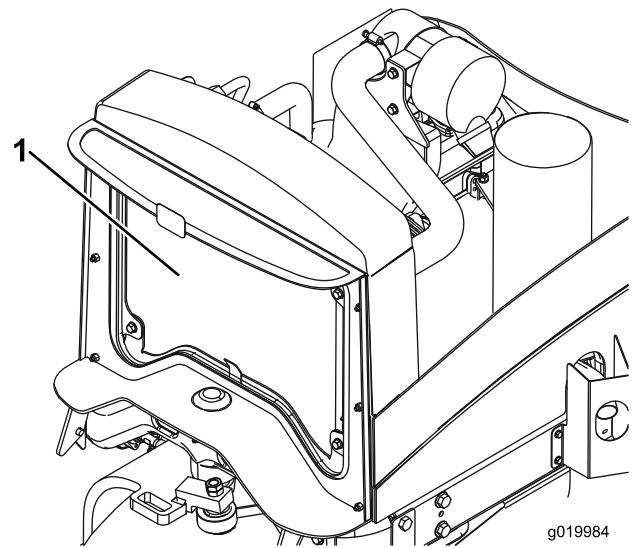

Figure 23

1. Radiator/Oil cooler

The cooling system is filled with a 50/50 solution of water and permanent ethylene glycol anti-freeze. Check the coolant level at the beginning of each day before starting the engine.

⚠ CAUTION

If the engine has been running, the pressurized, hot coolant can escape and cause burns.

- Do not open the radiator cap when the engine is running.
 - Use a rag when opening the radiator cap, and open the cap slowly to allow steam to escape.
1. Check the coolant level in the expansion tank (Figure 24). With a cold engine, the coolant level should be approximately midway between the marks on the side of the tank.
 2. If the coolant level is low, remove the expansion tank cap and replenish the system. **Do not overfill.**
 3. Install the expansion tank cap.

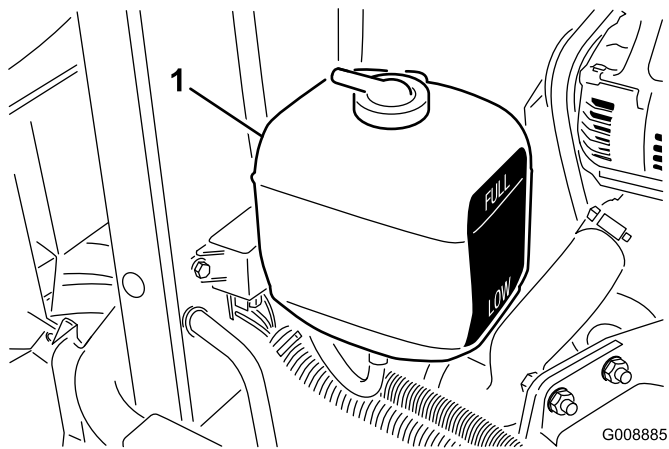

Figure 24

1. Expansion tank

Checking the Hydraulic System

Service Interval: Before each use or daily—Check the hydraulic fluid level.

The machine's reservoir is filled at the factory with approximately 6 U.S. gallons (22.7 l) of high quality hydraulic fluid. **Check the level of the hydraulic fluid before the engine is first started and daily thereafter.** The recommended replacement fluid is **Toro Premium All Season Hydraulic Fluid** (Available in 5 gallon pails or 55 gallon drums. See parts catalog or Toro distributor for part numbers.)

Alternate fluids: If the Toro fluid is not available, other fluids may be used provided they meet all the following material properties and industry specifications. Toro does not recommend the use of synthetic fluid. Consult with your lubricant distributor to identify a satisfactory product. **Note:** Toro will not assume responsibility for damage caused by improper substitutions, so use only products from reputable manufacturers who will stand behind their recommendation.

High Viscosity Index/Low Pour Point Anti-wear Hydraulic Fluid, ISO VG 46

Material Properties:

Viscosity, ASTM D445	cSt @ 40°C 44 to 48
	cSt @ 100°C 7.9 to 8.5
Viscosity Index ASTM D2270	140 to 160

Pour Point, ASTM D97	-34°F to -49°F
----------------------	----------------

Industry Specifications:

Vickers I-286-S (Quality Level), Vickers M-2950-S (Quality Level), Denison HF-0

Note: Many hydraulic fluids are almost colorless, making it difficult to spot leaks. A red dye additive for the hydraulic system oil is available in 2/3 oz. (20 ml) bottles. One bottle is sufficient for 4-6 U.S. gallons (15-22 l) of hydraulic oil. Order part no. 44-2500 from your authorized Toro distributor.

Biodegradable Hydraulic Fluid—Mobil 224H

Toro Biodegradable Hydraulic Fluid (Available in 5 gallon pails or 55 gallon drums. See parts catalog or Toro distributor for part numbers.)

Alternate fluid: Mobil EAL 224H

This is vegetable-oil based biodegradable oil tested and approved by Toro for this model. This fluid is not as resistant to high temperatures as standard fluid, so install an oil cooler if required by the operator manual and follow recommended fluid change intervals with this fluid. Contamination by mineral-based hydraulic fluids will change the biodegradability and toxicity of this oil. When changing from standard fluid to the biodegradable type, be certain to follow the approved flushing procedure. Contact your local Toro Distributor for details.

1. Position the machine on a level surface, lower the cutting units, and stop the engine.
2. Clean the area around the filler neck and cap of the hydraulic tank (Figure 25). Remove the cap.

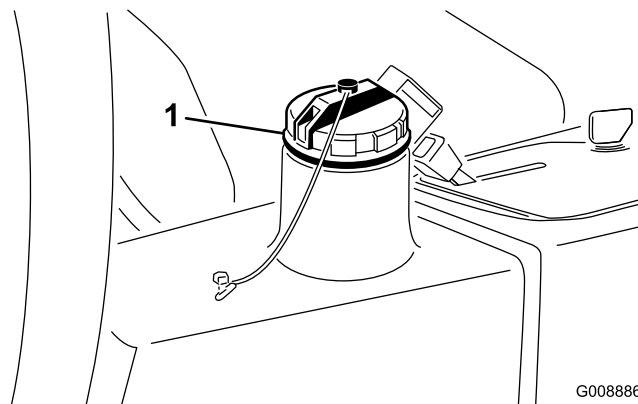

Figure 25

1. Hydraulic tank cap

3. Remove the dipstick from the filler neck and wipe it with a clean rag. Insert the dipstick into the filler neck; then remove it and check the fluid level. The fluid level should be within the marks on the dipstick.
4. If the level is low, add the appropriate fluid to raise the level to the full mark.
5. Install the dipstick and cap onto the filler neck.

Checking the Tire Pressure

Service Interval: Before each use or daily

The tires are over-inflated for shipping. Therefore, release some of the air to reduce the pressure. The correct air pressure in the tires is 14 to 18 psi (97 to 124 kPa).

Note: Maintain the recommended pressure in all tires to ensure a good quality of cut and proper machine performance.

⚠ DANGER

Low tire pressure decreases machine side hill stability. This could cause a rollover, which may result in personal injury or death.

Do not under-inflate the tires.

Torquing the Wheel Nuts

Service Interval: After the first hour

After the first 10 hours

Every 200 hours

Torque the wheel nuts to 45 to 65 ft-lb (61 to 88 N-m).

⚠ WARNING

Failure to maintain proper torque of the wheel nuts could result in personal injury.

Starting and Stopping the Engine

Starting the Engine

1. Be sure that the parking brake is set and the cutting unit drive switch is in the Disengage position.
2. Remove your foot from the traction pedal and make sure that the pedal is in the neutral position.
3. Move the throttle lever to the 1/2 throttle position.
4. Insert the key into the switch and rotate it to the Start position to engage the starter motor. Release the key when the engine starts. The key will move automatically to the On/Run position.

Important: To prevent overheating of the starter motor, do not engage the starter longer than 15 seconds. After 15 seconds of continuous cranking, wait 60 seconds before engaging the starter motor again.

Stopping the Engine

Move the throttle control to the Idle position, move the cutting unit drive switch to Disengage, and rotate the starter key to Off. Remove the key from the switch to prevent accidental starting.

Checking the Interlock System

Service Interval: Before each use or daily

⚠ CAUTION

If safety interlock switches are disconnected or damaged the machine could operate unexpectedly causing personal injury.

- Do not tamper with the interlock switches.
 - Check the operation of the interlock switches daily and replace any damaged switches before operating the machine.
1. Make sure that all bystanders are away from the area of operation. Keep hands and feet away from the cutting units.
 2. While sitting on the seat, the engine must not start with either the cutting unit switch engaged or the traction pedal engaged. Correct the problem if it is not operating properly.
 3. While sitting on the seat, put the traction pedal in neutral, the parking brake off, and the cutting unit switch in the Off position. The engine should start. Rise from the seat and slowly press the traction pedal, the engine should stop in one to three seconds. Correct problem if it is not operating properly.

Note: The machine is equipped with an interlock switch on the parking brake. The engine will stop if the traction pedal is pressed with the parking brake engaged.

Towing the Traction Unit

In case of an emergency, the machine can be towed for a short distance; however, Toro does not recommend this as a standard procedure.

Important: Do not tow the machine faster than 2 to 3 MPH (3 to 4 km/h) because the drive system may become damaged. If the machine must be moved a considerable distance, transport it on a truck or trailer.

1. Locate the bypass valve on the pump (Figure 26) and rotate it 90°.

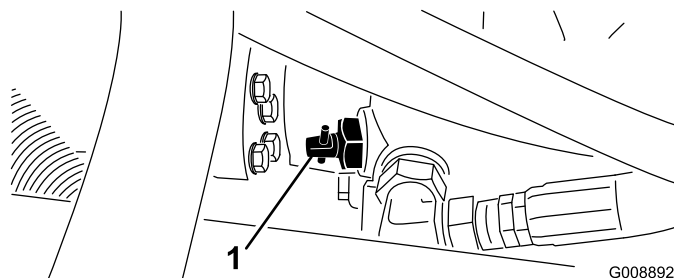

Figure 26

1. Bypass valve

- Before starting the engine, close the bypass valve by rotating it 90° (1/4 turn). Do not start the engine when the valve is open.

Standard Control Module (SCM)

The Standard Control Module is a potted electronic device produced in a one size fits all configuration. The module uses solid state and mechanical components to monitor and control standard electrical features required for safe product operation.

The module monitors inputs including neutral, parking brake, PTO, start, backlap, and high temperature. The module energizes outputs including PTO, Starter, and ETR (energize to run) solenoid.

The module is divided into inputs and outputs. Inputs and outputs are identified by green LED indicators mounted on the printed circuit board.

The start circuit input is energized by 12 VDC. All other inputs are energized when the circuit is closed to ground.

Each input has a LED that is illuminated when the specific circuit is energized. Use the input LED's for switch and input circuit troubleshooting.

Output circuits are energized by an appropriate set of input conditions. The three outputs include PTO, ETR, and START. Output LED's monitor relay condition indicating the presence of voltage at one of three specific output terminals.

Output circuits do not determine output device integrity so electrical troubleshooting includes output LED inspection and conventional device and wire harness integrity testing. Measure disconnected component impedance, impedance through wire harness (disconnect at SCM), or by temporarily "test energizing" the specific component.

The SCM does not connect to an external computer or hand held device, can not be re-programmed, and does not record intermittent fault troubleshooting data.

The decal on the SCM only includes symbols. Three LED output symbols are shown in the output box. All other LED's are inputs. The chart (Figure 27) identifies the symbols.

Inputs

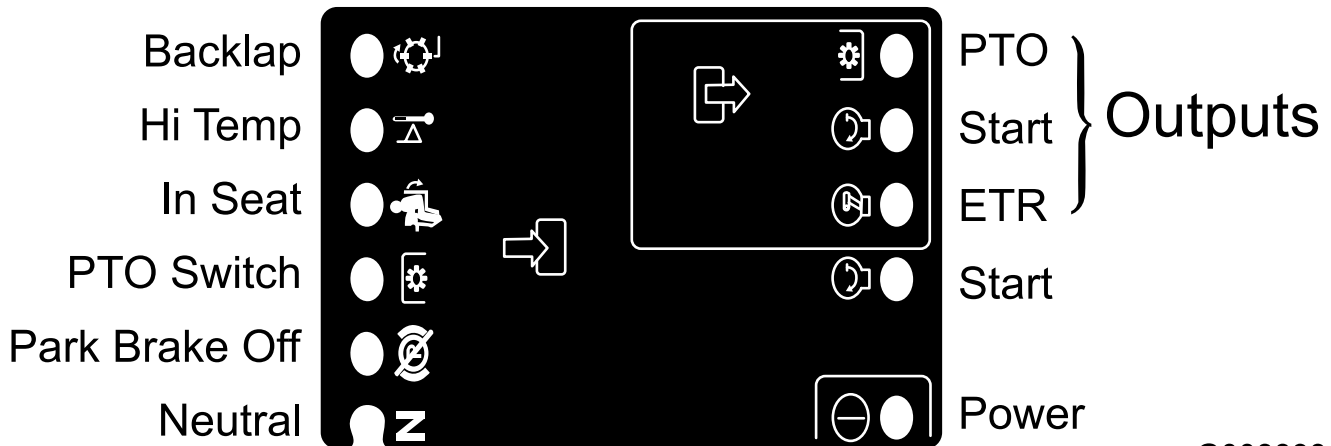

G008893

Figure 27

Here are the logical troubleshooting steps for the SCM device.

- Determine the output fault you are trying to resolve (PTO, START, or ETR).
- Move key switch to the On position and ensure that the red power LED is illuminated.
- Move all input switches to ensure all LED's change state.
- Position input devices at appropriate position to achieve the appropriate output. Use the following logic chart to determine the appropriate input condition.
- If specific output LED is illuminated without appropriate output function, check output harness, connections, and component. Repair as required.

- If specific output LED is not illuminated, check both fuses.
- If specific output LED is not illuminated and inputs are in appropriate condition, install new SCM and determine if fault disappears.

Each row (across) in the logic chart below identifies input and output requirements for each specific product function. Product functions are listed in the left column. Symbols identify specific circuit condition including: energized to voltage, closed to ground, and open to ground.

INPUTS									OUTPUTS		
Function	Power ON	In Neutral	Start ON	Brake ON	PTO ON	In Seat	Hi Temp	Backlap	Start	ETR	PTO
Start	—	—	+	O	O	—	O	O	+	+	O
Run (Off Unit)	—	—	O	O	O	O	O	O	O	+	O
Run (On Unit)	—	O	O	—	O	—	O	O	O	+	O
Mow	—	O	O	—	—	—	O	O	O	+	+
Backlap	—	—	O	O	—	O	O	—	O	+	+
Hi Temp	—		O				—		O	O	O

- (—) Indicates a circuit closed to ground. – LED ON
- (O) Indicates a circuit open to ground or de-energized – LED OFF
- (+) Indicates an energized circuit (clutch coil, solenoid, or start input) LED ON.
- A Blank indicates a circuit that is not involved with the logic.

To troubleshoot, turn on the key without starting the engine. Identify the specific function that does not work and work across the logic chart. Inspect the condition of each input LED's to ensure it matches the logic chart.

If the input LED's are correct, check the output LED. If the output LED is illuminated but the device is not energized, measure available voltage at the output device, continuity of the disconnected device, and potential voltage on the ground circuit (floating ground). Repairs will vary depending on your findings.

Operating Tips

General Tips

▲ DANGER

The mower has a unique traction system that will allow the machine to move forward on side hills, even if the uphill wheel should come off of the ground. If this should happen, the operator or any bystanders can be seriously injured or killed in a rollover.

The slope angle at which the machine will tip is dependent on many factors. Among these are: mowing conditions such as wet or undulating turf, speed (especially in turns), position of the cutting units (with Sidewinder), tire pressure, and operator experience.

At side hill angles of 20 degrees or less, the risk of a rollover is low. As the slope angle increases to a recommended maximum limit of 25 degrees, the risk of a rollover increases to a moderate level. *Do not exceed a 25 degree side hill slope angle because the risk of a rollover and serious injury or death is very high.*

To determine which hills or slopes you may safely operate on, a site survey of the mowing area must be done. When performing this site survey, always use common sense and take into consideration the turf condition and the rollover risk. To determine which hills or slopes may be safely operated on, use the inclinometer provided with each machine. To perform a site survey, lay a 4 ft 2x4 (1.25 meter plank) on the slope surface and measure the angle of the slope. The 2x4 will average the slope but will not take into consideration dips or holes which can cause a sudden change in side hill angle. *The maximum side hill angle should not be greater than 25 degrees.*

Additionally, the machine is equipped with an angle indicator mounted on the steering tube. This indicates the side hill angle the machine is on and identifies the recommended maximum limit of 25 degrees.

Always wear your seat belt.

- Practice operating the machine and become thoroughly familiar with it.
- Start the engine and run it at half idle until it warms up. Push the throttle lever all the way forward, lift the cutting units, disengage the parking brake, press the forward traction pedal, and carefully drive to an open area.

- Practice moving forward and reverse, and starting and stopping the machine. To stop, take your foot off of the traction pedal and let it return to neutral or press down on the reverse pedal to stop. Going down a hill, you may need to use the reverse pedal to stop.
- When driving on slopes, drive slowly to maintain steering control and avoid turns to prevent rollovers. In side hill situations you should shift the sidewinder cutting units to the uphill side to give you more stability. Conversely, shifting the cutting units to the down hill side will give you less stability. This should always be done before going on a side hill.
- When possible, mow up and down hills rather than across them. Have the cutting units lowered when going down a hill to maintain steering control. Do not attempt to turn on a hill.
- Practice driving around obstacles with the cutting units up and down. Be careful when driving between narrow objects so you do not damage the machine or cutting units.
- On the Sidewinder unit, get a feel for the reach of the cutting units so you do not hang them up or damage them in any way.
- Do not shift the units from side to side, unless the cutting units are down and the machine is moving, or the cutting units are up in the transport position. Shifting the cutting units when they are down and the machine is not moving may cause turf damage.
- Always drive slowly in rough areas.
- If a person appears in or near the operating area, stop the machine, and do not start it again until the area is cleared. The machine is designed for one person. Never let anyone else ride on the machine with you. This is extremely dangerous and could result in serious injury.
- Accidents can happen to anyone. The most common causes are excessive speed, sudden turns, terrain (not knowing which slopes and hills can be mowed safely), not stopping the engine before leaving the operator's seat, and drugs which impair your alertness. Cold capsules or prescription drugs may cause drowsiness, as can alcohol and other drugs. Stay alert and stay safe. Failure to do so could result in serious injury.
- The Sidewinder offers up to a maximum of 13 inches (33 cm) of overhang, allowing you to trim closer to the edge of sand traps and other obstacles, while at the same time keeping the tractor tires as far away from the edge of traps or water hazards as possible.
- If an obstacle is in the way, shift the cutting units to easily mow around it.
- When transporting the machine from one work area to another, raise the cutting units to the fully up position, move the mow/transport slide to the left to transport, and place the throttle in the Fast position.

Mowing Patterns

Change mowing patterns often to minimize aftercut appearance issues induced by repetitive operation in only one direction.

Counterbalance

The counterbalance system maintains hydraulic back pressure on the deck lift cylinders. This counterbalance pressure transfers cutting deck weight to the mower's drive wheels to improve traction. The counterbalance pressure has been factory set to an optimal balance of aftercut appearance and traction capability in most turf conditions. Decreasing the counterbalance setting can produce a more stable cutting deck, but can decrease the traction capability. Increasing the counterbalance setting can increase the traction capability, but may result in aftercut appearance issues. Reference the service manual for your traction unit for instructions to adjust counterbalance pressure.

Resolving Aftercut Appearance

Reference Aftercut Appearance Troubleshooting Guide available at www.Toro.com

Mowing Techniques

- To begin cutting, engage the cutting units, then approach the mowing area slowly. Once the front cutting units are over the mowing area, lower the cutting units.
- To achieve the professional straight-line cut and striping that is desirable for some applications, find a tree or other object in the distance and drive straight toward it.
- As soon as the front cutting units reach the edge of the mowing area, lift the cutting units and perform a tear drop shaped turn to quickly line you up for your next pass.
- To mow around bunkers, ponds, or other contours easily, use the Sidewinder and move the control lever left or right, depending on your mowing application. The cutting units can also be shifted to vary tire tracking.
- The cutting units tend to throw grass to the left side of the machine. If trimming around bunkers, it is best to mow in a clockwise direction to prevent throwing clippings into the bunker.
- The cutting units can be equipped with bolt-in mulching baffles. The mulching baffles perform well when turf is maintained on a regular schedule to avoid removing more than 1 inch (25 mm) of growth per cutting. When too much growth is cut with the mulching baffles installed, after-cut appearance may deteriorate and the observed power to cut the turf increases. The mulching baffles also perform well for shredding leaves in the fall of the year.

Mow When Grass is Dry

Mow either in the late morning to avoid the dew, which causes grass clumping, or in late afternoon to avoid the damage that can be caused by direct sunlight on the sensitive, freshly mowed grass.

Select the Proper Height-of-Cut Setting to Suit Conditions

Remove approximately one inch or no more than 1/3 of the grass blade when cutting. In exceptionally lush and dense grass you may have to raise your height-of-cut setting another notch.

Always Start Mowing with Sharp Blades

A sharp blade cuts cleanly and without tearing or shredding the grass blades like a dull blade. Tearing and shredding causes the grass to turn brown at the edges which impairs growth and increases susceptibility to diseases. Make sure blade is in good condition and a full sail is present.

Check Condition of cutting unit

Make sure cutting chambers are in good condition. Straighten any bends in chamber components to assure correct blade tip/chamber clearance.

After Mowing

At the completion of mowing operation, thoroughly wash the machine with a garden hose without a nozzle so that excessive water pressure will not cause contamination and damage to the seals and bearings. Make sure that the radiator and oil cooler are kept free of dirt or grass clippings. After cleaning, it is recommended that the machine be inspected for possible hydraulic fluid leaks, damage or wear to the hydraulic and mechanical components, and the cutting unit blades checked for sharpness.

Important: After washing the machine, move the Sidewinder mechanism from left to right several times to remove water between the bearing blocks and cross tube.

Maintenance

Note: Determine the left and right sides of the machine from the normal operating position.

Recommended Maintenance Schedule(s)

Maintenance Service Interval	Maintenance Procedure
After the first hour	<ul style="list-style-type: none"> • Torque the wheel nuts.
After the first 8 hours	<ul style="list-style-type: none"> • Check the condition and tension of all belts.
After the first 10 hours	<ul style="list-style-type: none"> • Torque the wheel nuts. • Change the hydraulic filter.
After the first 50 hours	<ul style="list-style-type: none"> • Change the oil and oil filter.
Before each use or daily	<ul style="list-style-type: none"> • Check the engine oil level. • Check the engine coolant level. • Check the hydraulic fluid level. • Check the tire pressure. • Check the interlock system. • Clean debris off of the radiator and oil cooler. • Check the hydraulic lines and hoses.
Every 25 hours	<ul style="list-style-type: none"> • Check the electrolyte level. (If machine is in storage, check every 30 days.)
Every 50 hours	<ul style="list-style-type: none"> • Lubricate all bearings and bushings. (Lubricate all bearings and bushings daily when conditions are dusty and dirty.)
Every 200 hours	<ul style="list-style-type: none"> • Torque the wheel nuts. • Service the Air Cleaner (More frequently in extreme dusty or dirty conditions) • Replace the carbon canister air filter • Change the oil and oil filter. • Check the parking brake adjustment. • Check the condition and tension of all belts. • Change the hydraulic filter.
Every 400 hours	<ul style="list-style-type: none"> • Replace the spark plugs • Replace the fuel pump filter • Check the fuel lines and connections. • Change the hydraulic fluid.
Every 500 hours	<ul style="list-style-type: none"> • Grease the bearings in the rear axle.
Every 2 years	<ul style="list-style-type: none"> • Drain and clean the fuel tank. • Flush the cooling system and replace fluid.

⚠ CAUTION

If you leave the key in the ignition switch, someone could accidentally start the engine and seriously injure you or other bystanders.

Remove the key from the ignition before you do any maintenance.

Daily Maintenance Checklist

Duplicate this page for routine use.

Maintenance Check Item	For the week of:						
	Mon.	Tues.	Wed.	Thurs.	Fri.	Sat.	Sun.
Check the safety interlock operation.							
Check the brake operation.							
Check the engine oil level.							
Check the cooling system fluid level.							
Check the air filter, dust cup, and burp valve.							
Check for unusual engine noises. ²							
Check the radiator and screen for debris							
Check for unusual operating noises.							
Check the hydraulic system oil level.							
Check the hydraulic hoses for damage.							
Check for fluid leaks.							
Check the fuel level.							
Check the tire pressure.							
Check the instrument operation.							
Check the height-of-cut adjustment.							
Lubricate all the grease fittings. ²							
Touch-up any damaged paint.							
¹ Check the glow plug and injector nozzles if starting is hard, there is excess smoke, or rough running is noted. ² Immediately after every washing, regardless of the interval listed.							

Important: Refer to your engine *Operator's Manual* for additional maintenance procedures.

Notation for Areas of Concern

Inspection performed by:		
Item	Date	Information

Service Interval Chart

GROUNDMASTER 3500-G

QUICK REFERENCE AID

CHECK/SERVICE (DAILY)

1. OIL LEVEL, ENGINE
2. ENGINE OIL DRAIN (14mm SOCKET)
3. OIL LEVEL HYDRAULIC TANK
4. COOLANT LEVEL, RADIATOR
5. AIR CLEANER
6. RADIATOR SCREEN
7. PARKING BRAKE
8. TIRE PRESSURE (14-18 psi)
9. BATTERY
10. BELTS (FAN, ALTERNATOR, HYDRAULIC PUMP)

GREASING - SEE OPERATOR'S MANUAL

FLUID SPECIFICATIONS / CHANGE INTERVALS

SEE OPERATOR'S MANUAL FOR INITIAL CHANGES.	FLUID TYPE	CAPACITY	CHANGE INTERVAL		FILTER PART NO.
			FLUID	FILTER	
A. ENGINE OIL	SAE 10W-30	3.6 QTS.*	200 HRS.	200 HRS.	115-8189
B. HYD. CIRCUIT OIL	ISO VG 46/68	6 GAL.*	400 HRS.	200 HRS.	86-3010
C. AIR CLEANER				200 HRS.	108-3811
D. FUEL TANK	UNLEADED GASOLINE	10 GALS.	DRAIN AND FLUSH, 2 YRS.		
E. COOLANT	50/50 ETHYLENE GLYCOL/WATER	7 QTS.	DRAIN AND FLUSH, 2 YRS.		

* INCLUDING FILTER

FUSES

MAIN 15A
MAX 15A OPTIONAL LIGHT
SYSTEM 10A GAUGES SCAM P/O
2A SCM
START 10A

121-3533

Figure 28

Premaintenance Procedures

Removing the Hood

The hood may be easily removed to ease maintenance procedures in the engine area of the machine.

1. Unlatch and raise the hood.
2. Remove the hairpin cotter securing the hood pivot to the mounting brackets (Figure 29).

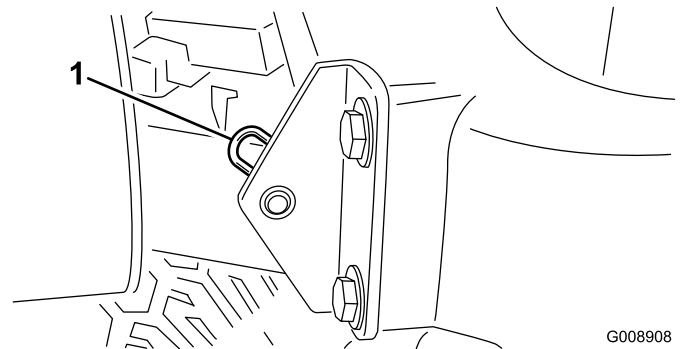

Figure 29

1. Hairpin cotter

3. Slide the hood to the right side, lift the other side, and pull it out of the brackets.

Note: Reverse the procedure to install the hood.

Lubrication

Greasing the Bearings And Bushings

Service Interval: Every 50 hours (Lubricate all bearings and bushings daily when conditions are dusty and dirty.)

Every 500 hours/Yearly (whichever comes first)

The machine has grease fittings that must be lubricated regularly with No. 2 General Purpose Lithium Base Grease. Bearings and bushings must be lubricated daily when operating conditions are extremely dusty and dirty. Dusty and dirty operating conditions could cause dirt to get into the bearings and bushings, resulting in accelerated wear. Lubricate grease fittings immediately after every washing, regardless of interval specified.

The grease fitting locations and quantities are:

- Rear cutting unit pivot (Figure 30)

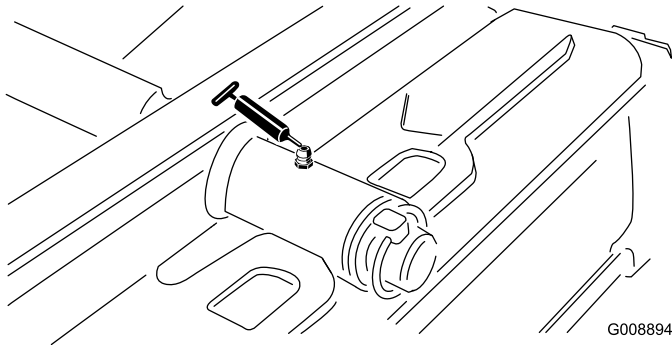

Figure 30

- Front cutting unit pivot (Figure 31)

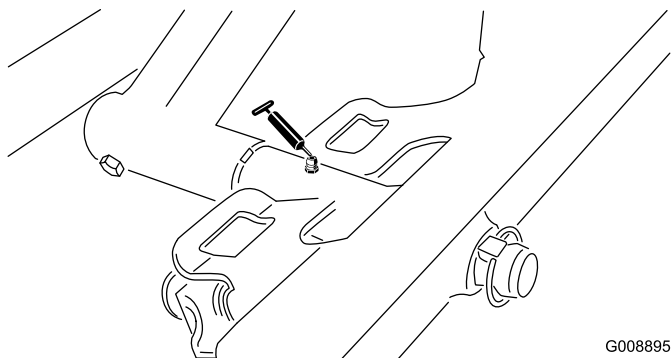

Figure 31

- SideWinder cylinder ends (2) (Figure 32)

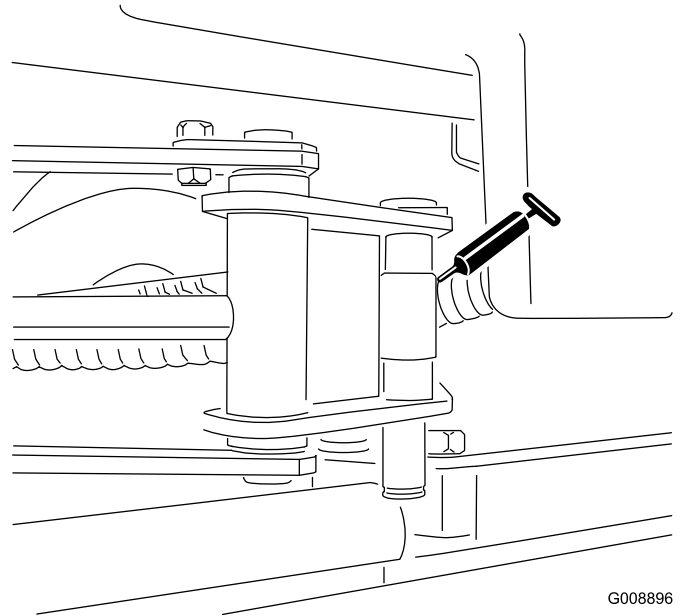

Figure 32

- Steering pivot (Figure 33)

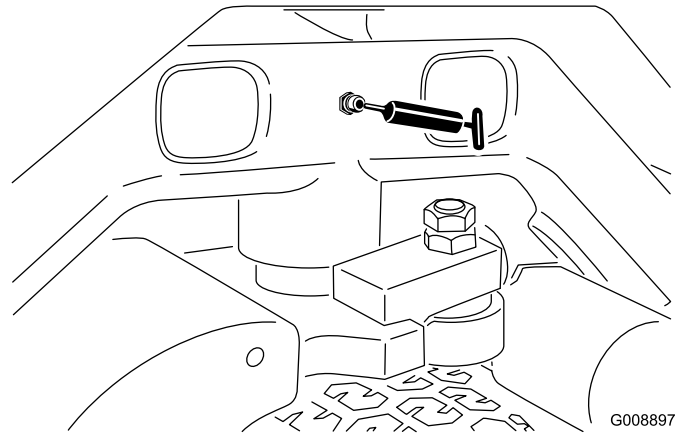

Figure 33

- Rear lift arm pivot and lift cylinder (2) (Figure 34)

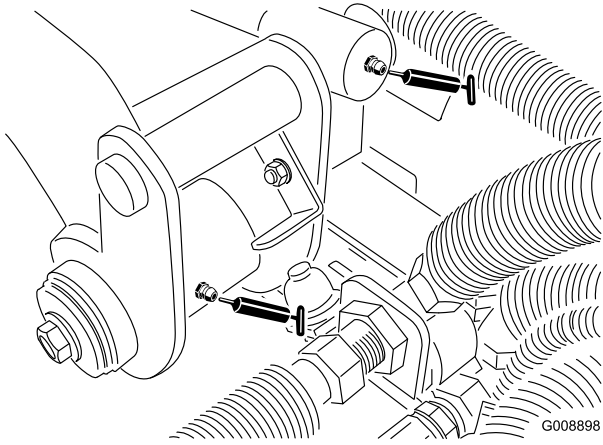

Figure 34

- Neutral adjust mechanism (Figure 37)

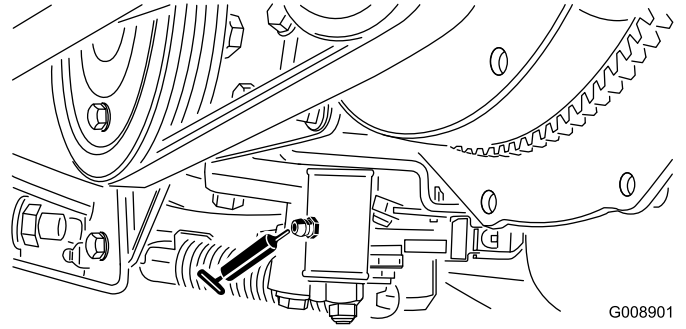

Figure 37

G008901

- Left front lift arm pivot and lift cylinder (2) (Figure 35)

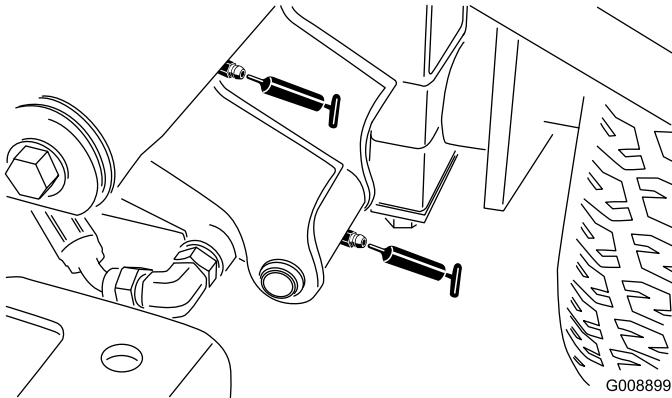

Figure 35

G008899

- Mow/transport slide (Figure 38)

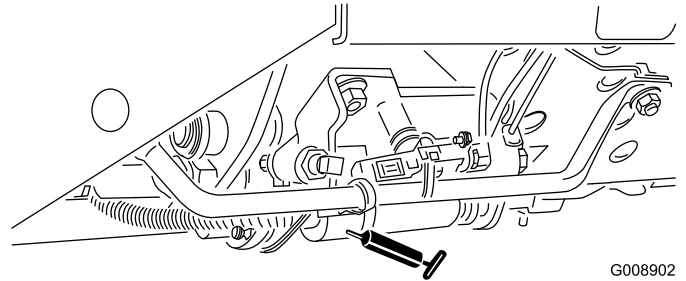

Figure 38

G008902

- Right front lift arm pivot and lift cylinder (2) (Figure 36)

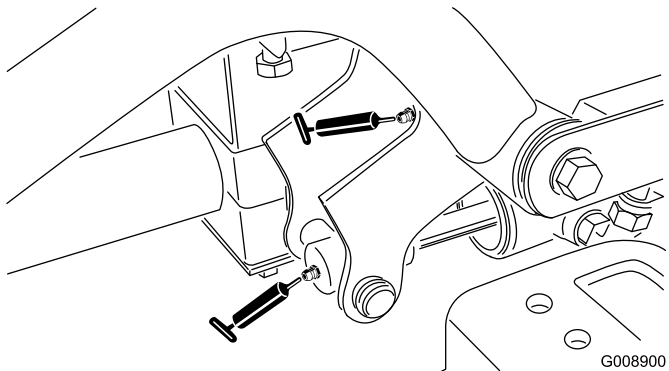

Figure 36

G008900

- Belt tension pivot (Figure 39)

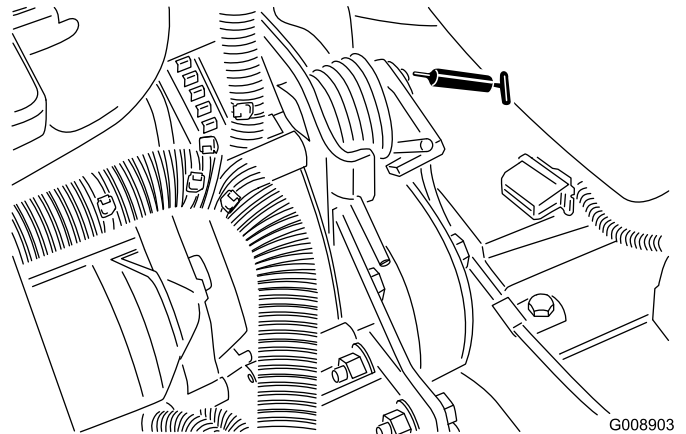

Figure 39

G008903

- Steering cylinder (Figure 40).

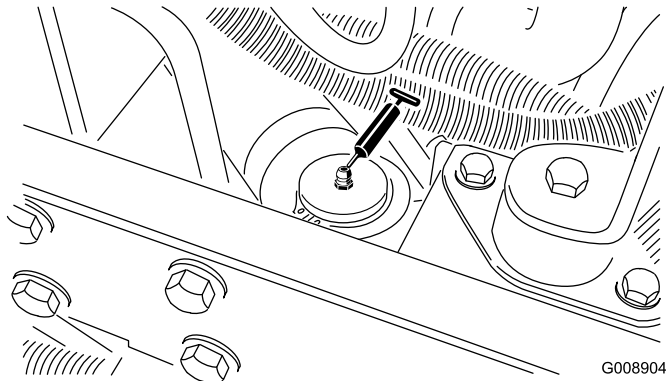

Figure 40

Note: If desired, an additional grease fitting may be installed in the other end of the steering cylinder. Remove the tire, install the fitting, grease the fitting, remove the fitting, and install the plug (Figure 41).

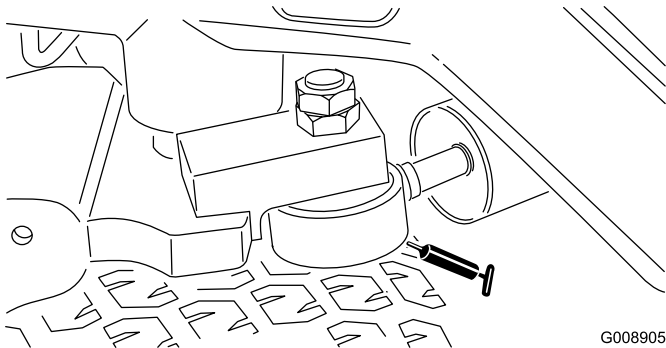

Figure 41

- Cutting unit spindle shaft bearings (1 per cutting unit) (Figure 42)

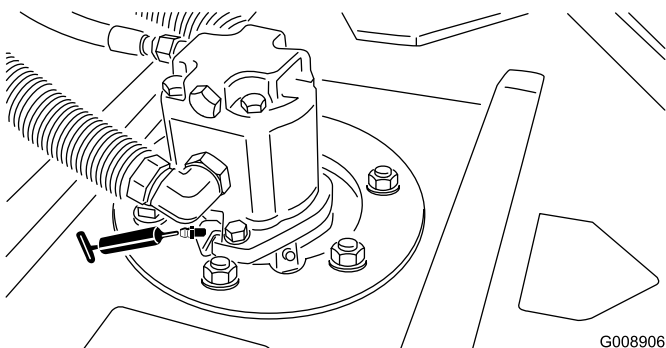

Figure 42

- Rear roller bearings (2 per cutting unit) (Figure 43)

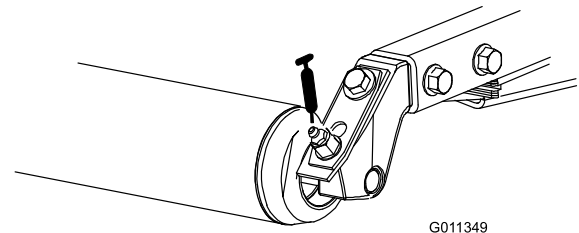

Figure 43

Note: The flush fittings on the rollers (Figure 43) require a grease gun nozzle adapter. Order Toro Part No. 107-1998 from your Authorized Toro Distributor.

Important: Do not lubricate the Sidewinder cross tube. The bearing blocks are self-lubricated.

Engine Maintenance

Servicing the Air Cleaner

Service Interval: Every 200 hours (More frequently in extreme dusty or dirty conditions)

Inspect the air cleaner and hoses periodically to maintain maximum engine protection and to ensure maximum service life. Check the air cleaner body for damage which could possibly cause an air leak. Replace a damaged air cleaner body.

Inspect and change the air cleaner filter as described in the following procedure:

1. Pull the latch outward and rotate the air cleaner cover counterclockwise.

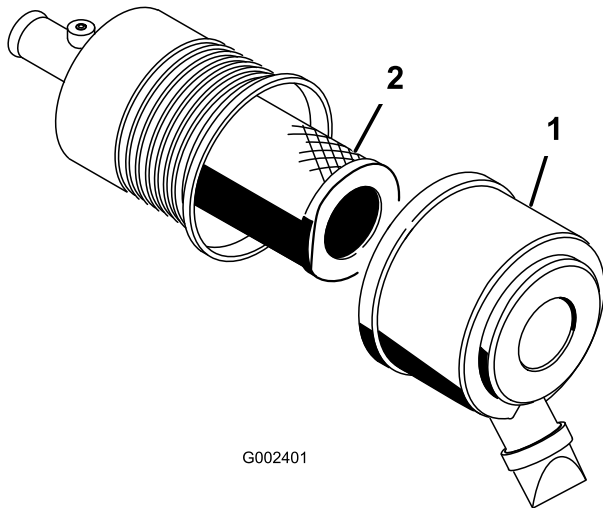

Figure 44

1. Air cleaner cover
2. Filter

2. Before removing the filter, use low pressure air (40 psi, clean and dry) to help remove large accumulations of debris packed between the outside of the primary filter and the canister.

Important: Avoid using high pressure air which could force dirt through the filter into the intake tract. This cleaning process prevents debris from migrating into the intake when the primary filter is removed.

3. Remove and replace the primary filter.

Note: Cleaning of the used element is not recommended due to the possibility of damage to the filter media.

4. Inspect the new filter for shipping damage, checking the sealing end of the filter and the body.

Important: Do not use a damaged element.

5. Insert the new filter by applying pressure to the outer rim of the element to seat it in the canister.

6. Clean the dirt ejection port located in the removable cover. Remove the rubber outlet valve from the cover, clean the cavity, and replace the outlet valve.
7. Install the cover orienting the rubber outlet valve in a downward position—between approximately 5:00 to 7:00 when viewed from the end.
8. Secure the cover latches.

Replacing the Carbon Canister Air Filter

Service Interval: Every 200 hours

1. Loosen the hose clamps securing the carbon canister air filter to the hoses (Figure 45). The carbon canister hoses and air filter are cable tied to the air cleaner hose.
2. Disconnect the hoses from the carbon canister air filter.
3. Remove and discard the carbon canister air filter (Figure 45). Note the direction the arrow is pointing on the filter.

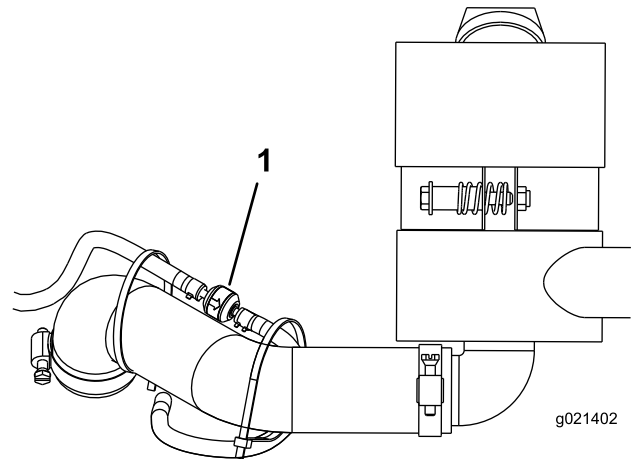

Figure 45

1. Carbon canister air filter

4. Install the new air filter with the arrow pointing toward the engine.
5. Connect the hoses to the carbon canister air filter with the hose clamps.

Changing the Engine Oil and Filter

Service Interval: After the first 50 hours

Every 200 hours

1. Remove the drain plug (Figure 46) and let oil flow into a drain pan. When the oil stops flowing, install the drain plug.

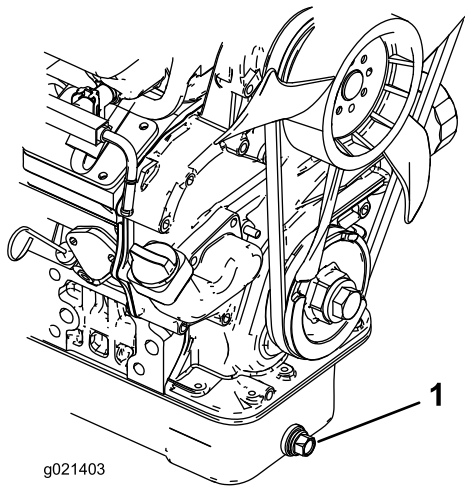

Figure 46

1. Engine oil drain plug

2. Remove the oil filter (Figure 47). Apply a light coat of clean oil to the new filter seal before screwing it on. **Do not overtighten.**

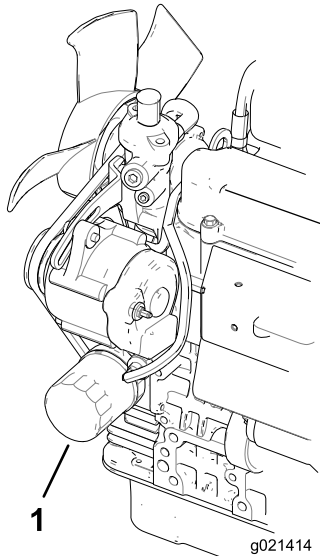

Figure 47

1. Engine oil filter

3. Add oil to the crankcase; refer to Checking the Engine Oil Level.

Replacing the Spark Plugs

Service Interval: Every 400 hours

The spark plugs usually last a long time; however, the plugs should be removed and checked whenever the engine malfunctions or every 400 hours. Replace the spark plugs to ensure proper engine performance and reduce exhaust emission level.

The correct spark plug to use is a Champion RC 14YC or NGK BPR 4ES.

1. Clean the area around the spark plugs so foreign matter cannot fall into the cylinder when you remove the spark plug.
2. Pull the wires off of the spark plugs and remove the plugs from the cylinder head.
3. Check the condition of the side electrode, center electrode, and center electrode insulator to ensure that there is no damage.

Important: A cracked, fouled, dirty, or otherwise malfunctioning spark plug must be replaced. Do not sand blast, scrape, or clean electrodes by using a wire brush because grit may eventually release from the plug and fall into the cylinder. The result is usually a damaged engine.

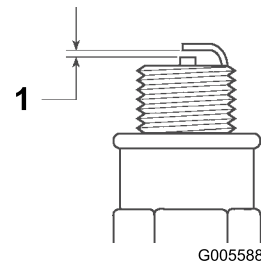

Figure 48

1. Air gap at 0.032 inch (0.81 mm)

4. Set the air gap on each plug between the center and side electrodes at 0.81 mm (0.032 inch).
5. Install the correctly gapped spark plugs and tighten them to 18 to 22 ft-lb (24.5 to 29 N-m). If you cannot use a torque wrench, tighten the plugs firmly.
6. Install the spark plug wires

Fuel System Maintenance

Replacing the Fuel Pump Filter

Service Interval: Every 400 hours

▲ DANGER

In certain conditions, gasoline is extremely flammable and highly explosive. A fire or explosion from gasoline can burn you and others and can damage property

- Drain gasoline from the fuel tank when the engine is cold. Do this outdoors in an open area. Wipe up any gasoline that spills.
- Never smoke when draining gasoline, and stay away from an open flame or where a spark may ignite the gasoline fumes.

1. Remove the seat from the machine to access the fuel pump (Figure 49).

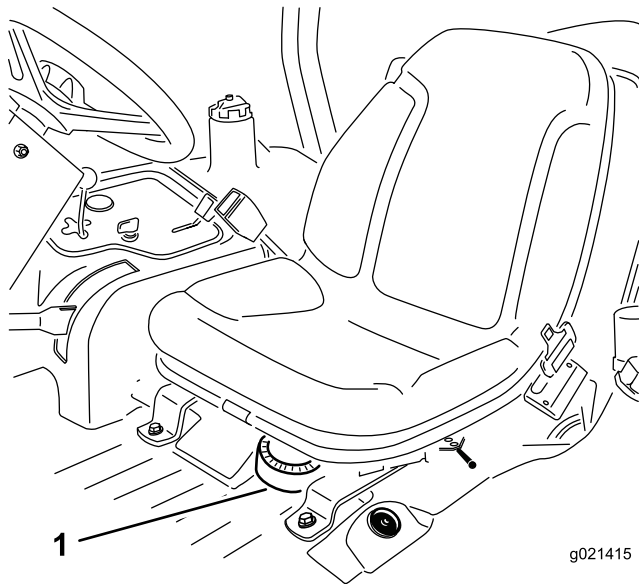

Figure 49

1. Fuel pump

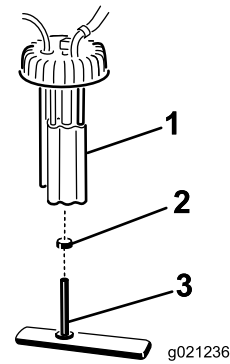

Figure 50

1. Fuel pump
2. Hose clamp
3. Fuel line/fuel filter

5. Insert the new hose clamp onto the new fuel filter hose.
6. Insert the hose onto the fuel pump and secure the clamp.
7. Insert the assembly into the fuel tank and tighten the cap to 175 to 200 in-lb (20 to 22 N-m).
8. Connect the wires and secure the hose with the hose clamp.
9. Install the seat.

Servicing the Fuel Tank

Service Interval: Every 2 years—Drain and clean the fuel tank.

Drain and clean the tank if the fuel system becomes contaminated or if the machine will be stored for an extended period of time. Use clean fuel to flush out the tank.

Inspecting the Fuel Lines and Connections

Service Interval: Every 400 hours/Yearly (whichever comes first)

Inspect the fuel lines and connections for deterioration, damage, or loose connections.

2. Unplug the wire harness connectors from the fuel pump (Figure 50).
3. Remove the fuel pump assembly and fuel filter from the tank (Figure 50).
4. Remove the clamp securing the fuel filter hose to the fuel pump fitting. Remove the hose from the fitting (Figure 50).

Electrical System Maintenance

Caring for the Battery

Service Interval: Every 25 hours—Check the electrolyte level. (If machine is in storage, check every 30 days.)

The battery electrolyte level must be properly maintained and the top of the battery kept clean. If the machine is stored in a location where temperatures are extremely high, the battery will run down more rapidly than if the machine is stored in a location where temperatures are cool.

Maintain the cell level with distilled or demineralized water. Do not fill the cells above the bottom of the split ring inside each cell. Install the filler caps with the vents pointing to the rear (toward the fuel tank).

⚠ DANGER

Battery electrolyte contains sulfuric acid which is a deadly poison and causes severe burns.

- Do not drink electrolyte and avoid contact with skin, eyes or clothing. Wear safety glasses to shield your eyes and rubber gloves to protect your hands.
- Fill the battery where clean water is always available for flushing the skin.

Keep the top of the battery clean by washing it periodically with a brush dipped in ammonia or bicarbonate of soda solution. Flush the top surface with water after cleaning. Do not remove the filler caps while cleaning.

The battery cables must be tight on the terminals to provide good electrical contact.

⚠ WARNING

Incorrect battery cable routing could damage the tractor and cables causing sparks. Sparks can cause the battery gasses to explode, resulting in personal injury.

- Always *disconnect* the negative (black) battery cable before disconnecting the positive (red) cable.
- Always *connect* the positive (red) battery cable before connecting the negative (black) cable.

If corrosion occurs at the terminals, disconnect the cables, negative (–) cable first, and scrape the clamps and terminals separately. Reconnect the cables, positive (+) cable first, and coat the terminals with petroleum jelly.

WARNING

CALIFORNIA Proposition 65 Warning

Battery posts, terminals, and related accessories contain lead and lead compounds, chemicals known to the State of California to cause cancer and reproductive harm.
Wash hands after handling.

Fuses

The fuses in machines electrical system are located under console cover.

Drive System Maintenance

Adjusting the Traction Drive for Neutral

If the machine moves when the traction pedal is in the neutral position, the traction cam must be adjusted.

1. Position the throttle lever rearward so it stops against the control panel slot.
2. Loosen the throttle cable connector on the injection pump lever arm (Figure 51).

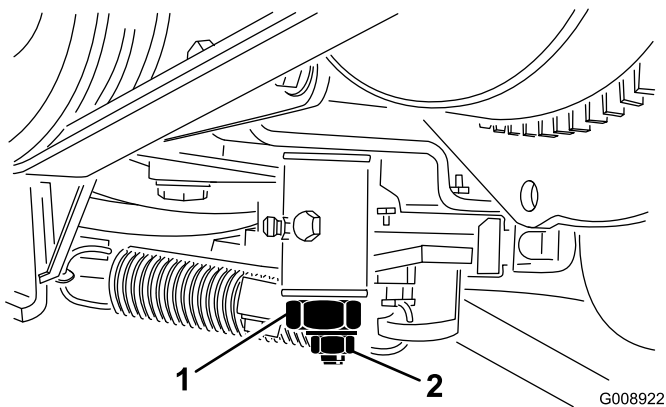

Figure 51

1. Injection pump lever arm
-
3. Hold the injection pump lever arm against the low idle stop and tighten the cable connector.
 4. Loosen the screws securing the throttle control to the control panel.
 5. Push the throttle control lever all of the way forward.
 6. Slide the stop plate until it contacts the throttle lever and tighten the screws securing the throttle control to the control panel.
 7. If the throttle does not stay in position during operation, torque the locknut, used to set the friction device on the throttle lever, to 40 to 55 in-lb (5 to 6 N-m). The maximum force required to operate the throttle lever should be 20 lb (27 N-m).

Cooling System Maintenance

Cleaning the Engine Cooling System

Service Interval: Before each use or daily

Every 2 years

Remove debris from the radiator/oil cooler daily. Clean them more frequently in dirty conditions.

1. Turn the engine off and raise the hood. Clean the engine area thoroughly of all debris.
2. Clean both sides of the radiator/oil cooler area thoroughly with water or compressed air (Figure 52).

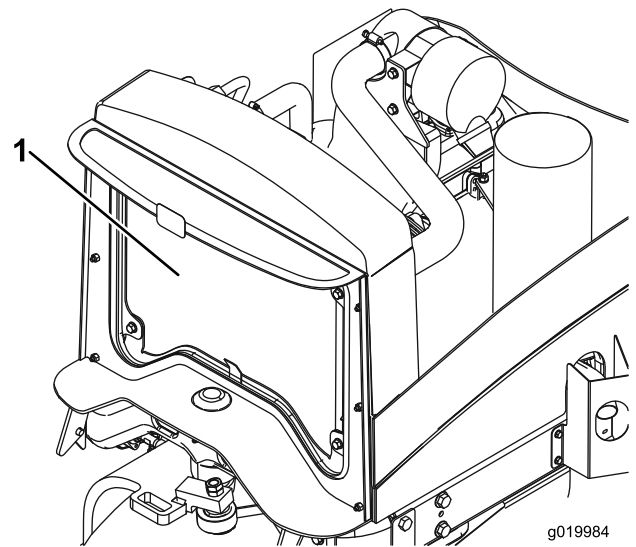

Figure 52

1. Radiator/Oil cooler
-
3. Close the hood.

Brake Maintenance

Adjusting the Parking Brake

Service Interval: Every 200 hours—Check the parking brake adjustment.

1. Loosen the set screw securing the knob to the parking brake lever (Figure 53).

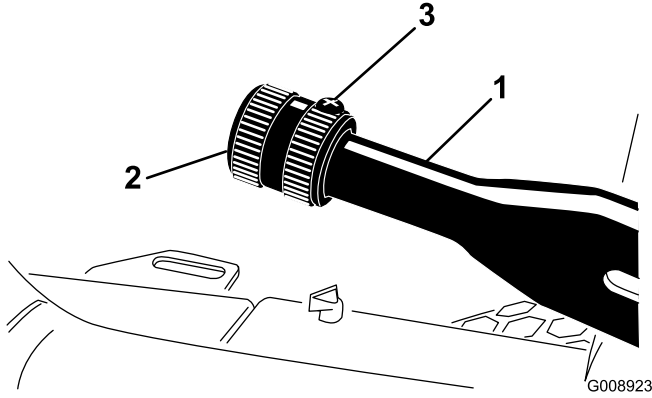

Figure 53

1. Parking brake lever
2. Knob
3. Set screw

2. Rotate the knob until a force of 30–40 lb (41–68 N-m) is required to actuate the lever.
3. Tighten the set screw after the adjustment has been attained.

Belt Maintenance

Servicing the Engine Belts

Service Interval: After the first 8 hours—Check the condition and tension of all belts.

Every 200 hours—Check the condition and tension of all belts.

Tensioning the Alternator/Fan Belt

1. Open the hood.
2. Check the tension by depressing the belt midway between the alternator and crankshaft pulleys with 22 lb (30 N-m) of force. A new belt should deflect 0.3 to 0.5 inch (8 to 12 mm). A used belt should deflect 0.4 to 0.55 inch (10 to 14 mm). If the deflection is incorrect, proceed to the next step. If correct, continue operation.

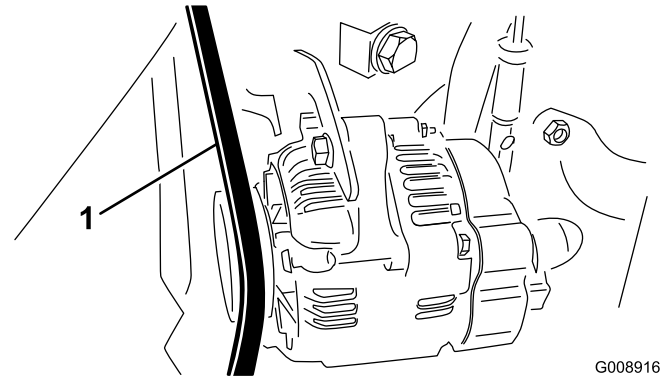

Figure 54

1. Alternator/fan belt

3. To adjust belt tension, complete the following:
 - A. Loosen the 2 alternator mounting bolts.
 - B. Using a bar, rotate the alternator until the proper belt tension is attained, then tighten the mounting bolts.

Replacing the Hydrostat Drive Belt

1. Insert a nut driver or small piece of tubing onto the end of the belt tensioning spring.

⚠ WARNING

Use caution when de-tensioning the spring, as it is under a heavy load.

2. Push down and forward on the spring end (Figure 55) to unhook it from the bracket and release tension on the spring.

Hydraulic System Maintenance

Changing the Hydraulic Filter

Service Interval: After the first 10 hours

Every 200 hours/Yearly (whichever comes first)

Use a genuine Toro replacement filter, Part No. 86-3010.

Important: Use of any other filter may void the warranty on some components.

1. Position the machine on a level surface, lower the cutting units, stop the engine, engage the parking brake, and remove the key from the ignition switch.
2. Pinch off the hose to the filter mounting plate.
3. Clean around the filter mounting area. Place a drain pan under the filter (Figure 56) and remove the filter.

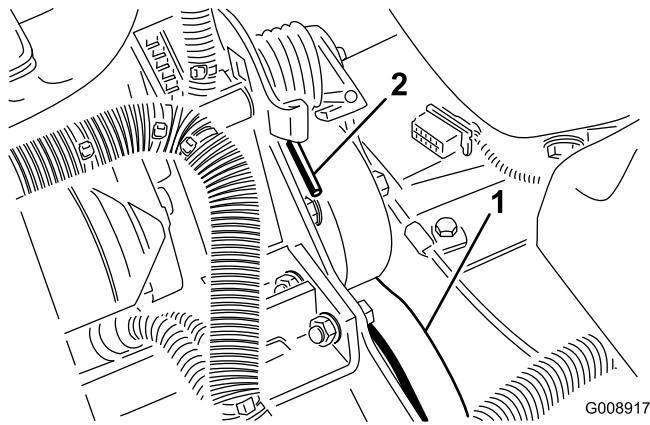

Figure 55

1. Hydrostat drive belt
 2. Spring end
-
3. Replace the belt.
 4. Reverse the procedure to tension the spring.

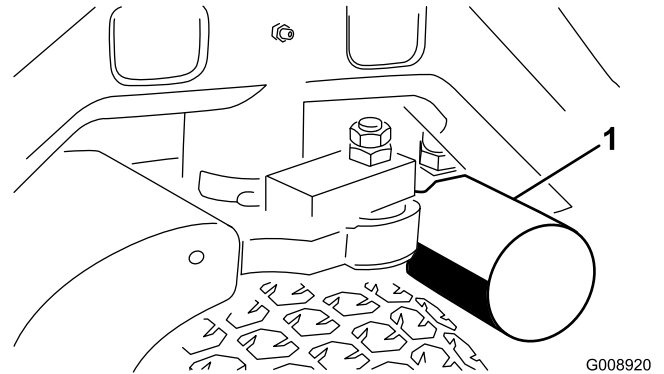

Figure 56

1. Hydraulic filter
-
4. Lubricate the new filter gasket and fill the filter with hydraulic fluid.
 5. Ensure that the filter mounting area is clean. Screw the filter on until the gasket contacts the mounting plate; then tighten the filter 1/2 turn.
 6. Release the hose to the filter mounting plate.
 7. Start the engine and let it run for about two minutes to purge air from the system. Stop the engine and check for leaks.

Changing the Hydraulic Fluid

Service Interval: Every 400 hours

If the fluid becomes contaminated, contact your local Toro distributor because the system must be flushed. Contaminated fluid looks milky or black when compared to clean oil.

1. Turn the engine off and raise the hood.
2. Disconnect the hydraulic line (Figure 57) or remove the hydraulic filter (Figure 56) and let the hydraulic fluid

flow into a drain pan. Install the hydraulic line when hydraulic fluid stops draining.

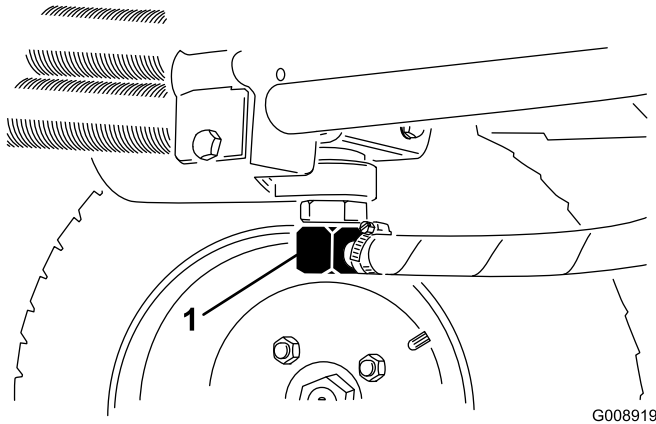

Figure 57

1. Hydraulic line

3. Fill the reservoir (Figure 58) with approximately 6 U.S. gallons (22.7 liters) of hydraulic fluid; refer to Checking the Hydraulic System.

Important: Use only the hydraulic fluids specified. Other fluids could cause system damage.

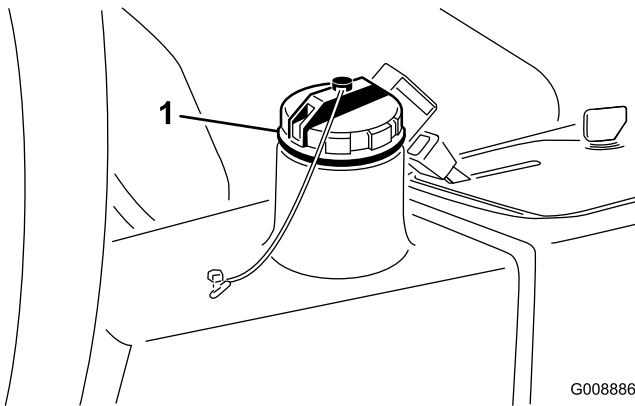

Figure 58

1. Hydraulic fill cap

4. Install the reservoir cap. Start the engine and use all of the hydraulic controls to distribute the hydraulic fluid throughout the system. Also check for leaks; then stop the engine.
5. Check the fluid level and add enough to raise the level to between marks on the dipstick. **Do not overfill.**

Checking the Hydraulic Lines and Hoses

Service Interval: Before each use or daily

Check hydraulic lines and hoses for leaks, kinked lines, loose mounting supports, wear, loose fittings, weather deterioration, and chemical deterioration. Make all necessary repairs before operating.

▲ WARNING

Hydraulic fluid escaping under pressure can penetrate skin and cause injury.

- Make sure all hydraulic fluid hoses and lines are in good condition and all hydraulic connections and fittings are tight before applying pressure to the hydraulic system.
- Keep your body and hands away from pin hole leaks or nozzles that eject high pressure hydraulic fluid.
- Use cardboard or paper to find hydraulic leaks.
- Safely relieve all pressure in the hydraulic system before performing any work on the hydraulic system.
- Seek immediate medical attention if fluid is injected into skin.

Storage

Storing the Battery

If the machine will be stored more than 30 days, remove the battery and charge it fully. Store the battery in a cool atmosphere to avoid quick deterioration of the charge in the battery. To prevent the battery from freezing, make sure it is fully charged. The specific gravity of a fully charged battery is 1.265–1.299.

Preparation for Seasonal Storage

Follow these procedures anytime you will be storing the machine for more than 30 days.

Traction Unit

1. Thoroughly clean the traction unit, cutting units, and engine.
2. Check the tire pressure. Inflate all tires to 14 to 18 psi (97 to 110 kPa).
3. Check all fasteners for looseness; tighten as necessary.
4. Grease or oil all grease fittings and pivot points. Wipe up any excess lubricant.
5. Lightly sand and use touch-up paint on painted areas that are scratched, chipped, or rusted. Repair any dents in the metal body.
6. Service the battery and cables as follows:
 - A. Remove the battery terminals from the battery posts.
 - B. Remove the battery.
 - C. Slowly recharge the battery before storage and every 60 days thereafter for 24 hours to prevent lead sulfation of the battery.

To prevent the battery from freezing, make sure it is fully charged. The specific gravity of a fully charged battery is 1.265–1.299.
 - D. Clean the battery, terminals, and posts with a wire brush and baking soda solution.
 - E. Coat the cable terminals and battery posts with Grafo 112X skin-over grease (Toro Part No. 505-47) or petroleum jelly to prevent corrosion.
 - F. Either store it on the shelf or on the machine in a cool area. Leave the cables disconnected if it is stored on the machine.

Engine

1. Drain the engine oil from the oil pan and replace the drain plug.
2. Remove and discard the oil filter. Install a new oil filter.
3. Refill the oil pan with 3.5 qt (3.3 l) of motor oil.
4. Start the engine and run it at idle speed for approximately two minutes.
5. Stop the engine.
6. For storage over 30 days, prepare the fuel system as follows:
 - Add a petroleum based stabilizer/conditioner to fuel in the tank.

Follow the mixing instructions from stabilizer manufacturer. Do not use an alcohol based stabilizer (ethanol or methanol).

Note: A fuel stabilizer/conditioner is most effective when mixed with fresh gasoline and used at all times.

- Run the engine to distribute conditioned fuel through the fuel system (5 minutes).
- Stop the engine, allow it to cool, and drain the fuel tank.
- Restart the engine and run it until it stops.
- Start and run the engine until it will not start again.
- Dispose of fuel properly. Recycle as per local codes

Important: Do not store stabilizer/conditioned gasoline over 90 days

7. Remove the spark plugs and check their condition; refer to Changing the Spark Plugs.
8. With the spark plugs removed from the engine, pour two tablespoons of engine oil into the spark plug hole.
9. Use the starter to crank the engine and distribute the oil inside the cylinder.
10. Install the spark plugs and tighten to recommended torque; refer to Changing the Spark Plugs.

Note: Do not install the wires on the spark plugs.
11. Check anti-freeze protection and add as needed for expected minimum temperature in your area.
12. Secure all fuel system fittings.
13. Thoroughly clean and service the air cleaner assembly.
14. Seal the air cleaner inlet and the exhaust outlet with weatherproof tape.

Schematics

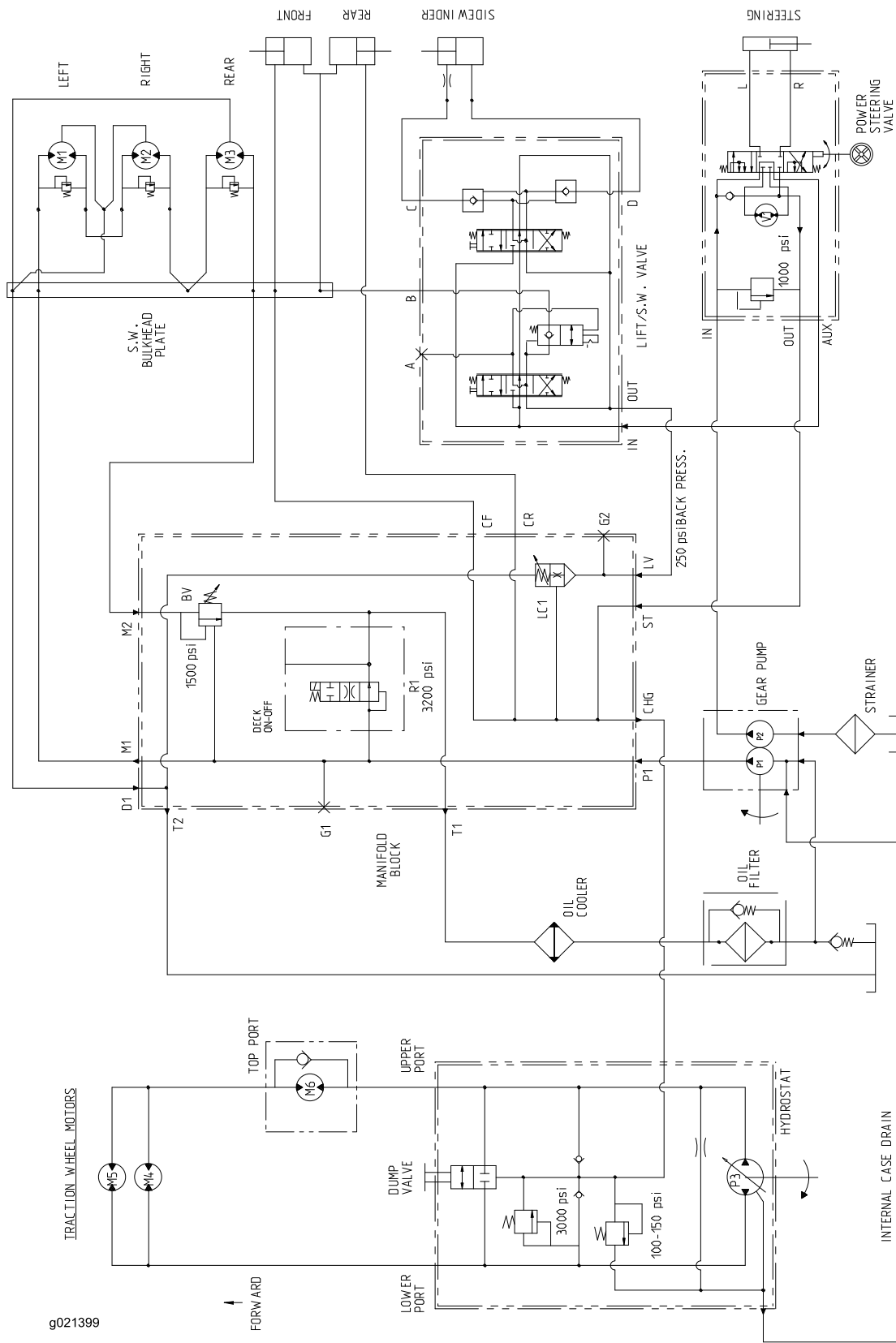

g021399

Hydraulic Schematic (Rev. A)

Notes:

Notes:

Notes:



The Toro Total Coverage Guarantee

A Limited Warranty

Conditions and Products Covered

The Toro Company and its affiliate, Toro Warranty Company, pursuant to an agreement between them, jointly warrant your Toro Commercial product ("Product") to be free from defects in materials or workmanship for two years or 1500 operational hours*, whichever occurs first. This warranty is applicable to all products with the exception of Aerators (refer to separate warranty statements for these products). Where a warrantable condition exists, we will repair the Product at no cost to you including diagnostics, labor, parts, and transportation. This warranty begins on the date the Product is delivered to the original retail purchaser.

* Product equipped with an hour meter.

Instructions for Obtaining Warranty Service

You are responsible for notifying the Commercial Products Distributor or Authorized Commercial Products Dealer from whom you purchased the Product as soon as you believe a warrantable condition exists. If you need help locating a Commercial Products Distributor or Authorized Dealer, or if you have questions regarding your warranty rights or responsibilities, you may contact us at:

Toro Commercial Products Service Department
Toro Warranty Company
8111 Lyndale Avenue South
Bloomington, MN 55420-1196
952-888-8801 or 800-952-2740
E-mail: commercial.warranty@toro.com

Owner Responsibilities

As the Product owner, you are responsible for required maintenance and adjustments stated in your *Operator's Manual*. Failure to perform required maintenance and adjustments can be grounds for disallowing a warranty claim.

Items and Conditions Not Covered

Not all product failures or malfunctions that occur during the warranty period are defects in materials or workmanship. This warranty does not cover the following:

- Product failures which result from the use of non-Toro replacement parts, or from installation and use of add-on, or modified non-Toro branded accessories and products. A separate warranty may be provided by the manufacturer of these items.
- Product failures which result from failure to perform recommended maintenance and/or adjustments. Failure to properly maintain your Toro product per the Recommended Maintenance listed in the *Operator's Manual* can result in claims for warranty being denied.
- Product failures which result from operating the Product in an abusive, negligent, or reckless manner.
- Parts subject to consumption through use unless found to be defective. Examples of parts which are consumed, or used up, during normal Product operation include, but are not limited to, brake pads and linings, clutch linings, blades, reels, rollers and bearings (sealed or greasable), bed knives, spark plugs, castor wheels and bearings, tires, filters, belts, and certain sprayer components such as diaphragms, nozzles, and check valves, etc.
- Failures caused by outside influence. Conditions considered to be outside influence include, but are not limited to, weather, storage practices, contamination, use of unapproved fuels, coolants, lubricants, additives, fertilizers, water, or chemicals, etc.
- Failure or performance issues due to the use of fuels (e.g. gasoline, diesel, or biodiesel) that do not conform to their respective industry standards.

Countries Other than the United States or Canada

Customers who have purchased Toro products exported from the United States or Canada should contact their Toro Distributor (Dealer) to obtain guarantee policies for your country, province, or state. If for any reason you are dissatisfied with your Distributor's service or have difficulty obtaining guarantee information, contact the Toro importer.

- Normal noise, vibration, wear and tear, and deterioration.
- Normal "wear and tear" includes, but is not limited to, damage to seats due to wear or abrasion, worn painted surfaces, scratched decals or windows, etc.

Parts

Parts scheduled for replacement as required maintenance are warranted for the period of time up to the scheduled replacement time for that part. Parts replaced under this warranty are covered for the duration of the original product warranty and become the property of Toro. Toro will make the final decision whether to repair any existing part or assembly or replace it. Toro may use remanufactured parts for warranty repairs.

Deep Cycle and Lithium-Ion Battery Warranty:

Deep cycle and Lithium-Ion batteries have a specified total number of kilowatt-hours they can deliver during their lifetime. Operating, recharging, and maintenance techniques can extend or reduce total battery life. As the batteries in this product are consumed, the amount of useful work between charging intervals will slowly decrease until the battery is completely worn out. Replacement of worn out batteries, due to normal consumption, is the responsibility of the product owner. Battery replacement may be required during the normal product warranty period at owner's expense. Note: (Lithium-Ion battery only): A Lithium-Ion battery has a part only prorated warranty beginning year 3 through year 5 based on the time in service and kilowatt hours used. Refer to the *Operator's Manual* for additional information.

Maintenance is at Owner's Expense

Engine tune-up, lubrication, cleaning and polishing, replacement of filters, coolant, and completing recommended maintenance are some of the normal services Toro products require that are at the owner's expense.

General Conditions

Repair by an Authorized Toro Distributor or Dealer is your sole remedy under this warranty.

Neither The Toro Company nor Toro Warranty Company is liable for indirect, incidental or consequential damages in connection with the use of the Toro Products covered by this warranty, including any cost or expense of providing substitute equipment or service during reasonable periods of malfunction or non-use pending completion of repairs under this warranty. Except for the Emissions warranty referenced below, if applicable, there is no other express warranty. All implied warranties of merchantability and fitness for use are limited to the duration of this express warranty.

Some states do not allow exclusions of incidental or consequential damages, or limitations on how long an implied warranty lasts, so the above exclusions and limitations may not apply to you. This warranty gives you specific legal rights, and you may also have other rights which vary from state to state.

Note regarding engine warranty:

The Emissions Control System on your Product may be covered by a separate warranty meeting requirements established by the U.S. Environmental Protection Agency (EPA) and/or the California Air Resources Board (CARB). The hour limitations set forth above do not apply to the Emissions Control System Warranty. Refer to the Engine Emission Control Warranty Statement supplied with your product or contained in the engine manufacturer's documentation for details