



Count on it.

Operator's Manual

**Commercial Walk-Behind Mower
Floating Deck, T-Bar, Gear Drive with 36in or
48in TURBO FORCE® Cutting Unit**

Model No. 30074—Serial No. 31300001 and Up

Model No. 30078—Serial No. 31300001 and Up

Model No. 39074—Serial No. 31300001 and Up

Model No. 39078—Serial No. 31300001 and Up

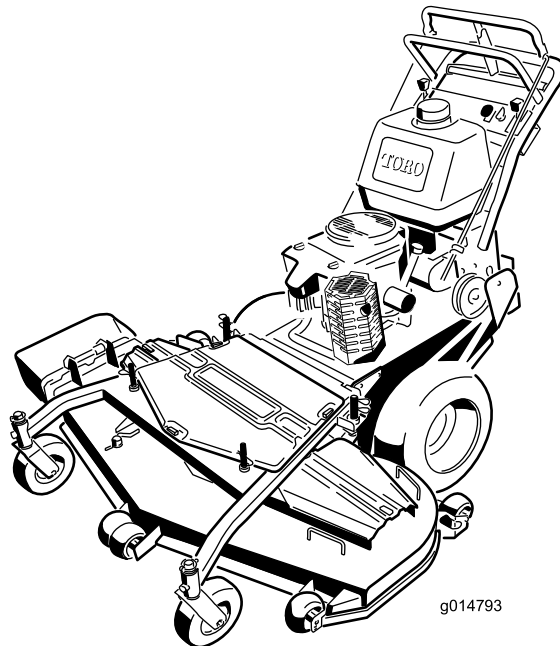

g014793



⚠ WARNING

CALIFORNIA Proposition 65 Warning

This product contains a chemical or chemicals known to the State of California to cause cancer, birth defects, or reproductive harm.

The engine exhaust from this product contains chemicals known to the State of California to cause cancer, birth defects, or other reproductive harm.

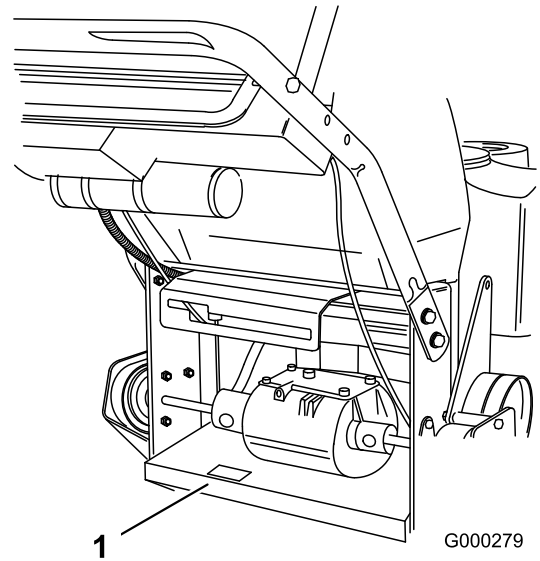

Figure 1

1. Model and serial number location

This spark ignition system complies with Canadian ICES-002.

Important: This engine is not equipped with a spark arrester muffler. It is a violation of California Public Resource Code Section 4442 to use or operate the engine on any forest-covered, brush-covered, or grass-covered land. Other states or federal areas may have similar laws.

The enclosed *Engine Owner's Manual* is supplied for information regarding the US Environmental Protection Agency (EPA) and the California Emission Control Regulation of emission systems, maintenance, and warranty. Replacements may be ordered through the engine manufacturer.

Model No. _____
Serial No. _____

This manual identifies potential hazards and has safety messages identified by the safety alert symbol (Figure 2), which signals a hazard that may cause serious injury or death if you do not follow the recommended precautions.

Introduction

This rotary-blade, lawn mower is intended to be used by professional, hired operators or residential homeowners. It is designed primarily for cutting grass on well-maintained lawns on residential or commercial properties. It is not designed for cutting brush or for agricultural uses.

Read this information carefully to learn how to operate and maintain your product properly and to avoid injury and product damage. You are responsible for operating the product properly and safely.

You may contact Toro directly at www.Toro.com for product and accessory information, help finding a dealer, or to register your product.

Whenever you need service, genuine Toro parts, or additional information, contact an Authorized Service Dealer or Toro Customer Service and have the model and serial numbers of your product ready. Figure 1 identifies the location of the model and serial numbers on the product. Write the numbers in the space provided.



Figure 2

1. Safety alert symbol

This manual uses 2 other words to highlight information. **Important** calls attention to special mechanical information and **Note** emphasizes general information worthy of special attention.

Contents

Introduction	2
Safety	4
Safe Operating Practices	4
Toro Mower Safety	5
Slope Indicator	6
Safety and Instructional Decals	7
Product Overview	9
Controls	9
Specifications	10
Attachments/Accessories	10
Operation	11
Adding Fuel	11
Checking the Engine Oil Level	12
Think Safety First	12
Using the Parking Brake	12
Starting and Stopping the Engine	12
Operating the Mower Power Take Off (PTO)	13
The Safety Interlock System	13
Driving Forward or Backward	14
Using the Lower Control Bar	14
Stopping the Machine	15
Transporting Machines	15
Side Discharging or Mulching the Grass	16
Adjusting the Height-of-Cut	16
Adjusting the Anti-Scalp Rollers	16
Adjusting the Handle Height	17
Adjusting the Flow Baffle	18
Positioning the Flow Baffle	18
Using the Mid-Size Weight	19
Maintenance	21
Recommended Maintenance Schedule(s)	21
Lubrication	22
How to Grease	22
Lubricating the Caster and Wheel Bearings	22
Greasing the Transmission Couplers	22
Greasing the PTO Drive Belt Idler and Mower Deck Belt Idler	22
Engine Maintenance	23
Servicing the Air Cleaner	23
Servicing the Engine Oil	24
Servicing the Spark Plugs	26
Fuel System Maintenance	27
Draining the Fuel Tank	27
Replacing the Fuel Filter	27
Electrical System Maintenance	28
Servicing the Fuse	28
Drive System Maintenance	28
Adjusting the Control Bar	28
Checking the Tire Pressure	29
Replacing the Caster Wheel Fork Bushings	29
Servicing the Caster Wheel and Bearings	30
Adjusting the Electric Clutch	30
Cooling System Maintenance	31
Cleaning the Air Intake Screen	31
Brake Maintenance	32

Servicing the Brakes	32
Belt Maintenance	33
Replacing the Traction Drive Belt	33
Replacing the Transmission Belt	33
Replacing the Mower Belt	33
Replacing the PTO Drive Belt	34
Adjusting the PTO Drive Belt Idler Spring Anchor	35
Mower Deck Maintenance	36
Servicing the Cutting Blades	36
Correcting the Mower Quality of Cut	38
Frame Set Up	38
Checking the Mower Deck Front-to-Rear Pitch	40
Changing the Mower Deck Front-to-Rear Pitch	40
Checking the Mower Deck Side-to-Side Height	41
Changing the Mower Deck Side-to-Side Height	41
Matching Height of Cut	41
Replacing the Grass Deflector	42
Storage	43
Cleaning and Storage	43
Troubleshooting	44
Schematics	46

Safety

Note: The addition of attachments made by other manufacturers that do not meet American National Standards Institute certification will cause noncompliance of this machine.

Improper use or maintenance by the operator or owner can result in injury. To reduce the potential for injury, comply with these safety instructions and always pay attention to the safety alert symbol , which means CAUTION, WARNING, or DANGER—"personal safety instruction." Failure to comply with the instruction may result in personal injury or death.

Safe Operating Practices

The following instructions are from ANSI standard B71.4-2004.

Training

- Read the *Operator's Manual* and other training material. If the operator(s) or mechanic(s) can not read English it is the owner's responsibility to explain this material to them.
- Become familiar with the safe operation of the equipment, operator controls, and safety signs.
- All operators and mechanics should be trained. The owner is responsible for training the users.
- Never let children or untrained people operate or service the equipment. Local regulations may restrict the age of the operator.
- The owner/user can prevent and is responsible for accidents or injuries occurring to himself or herself, other people or property.

Preparation

- Evaluate the terrain to determine what accessories and attachments are needed to properly and safely perform the job. Only use accessories and attachments approved by the manufacturer.
- Wear appropriate clothing including hard hat, safety glasses and hearing protection. Long hair, loose clothing or jewelry may get tangled in moving parts.
- Inspect the area where the equipment is to be used and remove all objects such as rocks, toys and wire which can be thrown by the machine.
- Use extra care when handling gasoline and other fuels. They are flammable and vapors are explosive.
 - Use only an approved container
 - Never remove gas cap or add fuel with engine running. Allow engine to cool before refueling. Do not smoke.
 - Never refuel or drain the machine indoors.
- Check that operator's presence controls, safety switches and shields are attached and functioning properly. Do not operate unless they are functioning properly.

Operation

- Lightning can cause severe injury or death. If lightning is seen or thunder is heard in the area, do not operate the machine; seek shelter.
- Never run an engine in an enclosed area.
- Only operate in good light, keeping away from holes and hidden hazards.
- Be sure all drives are in neutral and parking brake is engaged before starting engine. Only start engine from the operator's position.
- Be sure of your footing while using this machine, especially when backing up. Walk, don't run. Never operate on wet grass. Reduced footing could cause slipping.
- Slow down and use extra care on hillsides. Be sure to travel side to side on hillsides. Turf conditions can affect the machine's stability. Use caution while operating near drop-offs.
- Slow down and use caution when making turns and when changing directions on slopes.
- Never raise deck with the blades running.
- Never operate with the PTO shield, or other guards not securely in place. Be sure all interlocks are attached, adjusted properly, and functioning properly.
- Never operate with the discharge deflector raised, removed or altered, unless using a grass catcher.
- Do not change the engine governor setting or overspeed the engine.
- Stop on level ground, disengage drives, engage parking brake, shut off engine before leaving the operator's position for any reason including emptying the catchers or unclogging the chute.
- Stop equipment and inspect blades after striking objects or if an abnormal vibration occurs. Make necessary repairs before resuming operations.
- Keep hands and feet away from the cutting unit.
- Look behind and down before backing up to be sure of a clear path.
- Keep pets and bystanders away.
- Slow down and use caution when making turns and crossing roads and sidewalks. Stop blades if not mowing.
- Be aware of the mower discharge direction and do not point it at anyone.
- Do not operate the mower under the influence of alcohol or drugs.
- Use care when loading or unloading the machine into or from a trailer or truck.
- Use care when approaching blind corners, shrubs, trees, or other objects that may obscure vision.

Maintenance and storage

- Disengage drives, set parking brake, stop engine and remove key or disconnect spark plug wire. Wait for all movement to stop before adjusting, cleaning or repairing.
- Clean grass and debris from cutting unit, drives, mufflers, and engine to help prevent fires. Clean up oil or fuel spillage.
- Let engine cool before storing and do not store near flame.
- Shut off fuel while storing or transporting. Do not store fuel near flames or drain indoors.
- Park machine on level ground. Set parking brake. Never allow untrained personnel to service machine.
- Use jack stands to support components when required.
- Carefully release pressure from components with stored energy.
- Disconnect the battery or remove spark plug wire before making any repairs. Disconnect the negative terminal first and the positive last. Reconnect the positive first and negative last.
- Use care when checking blades. Wrap the blade(s) or wear gloves, and use caution when servicing them. Only replace blades. Never straighten or weld them.
- Keep hands and feet away from moving parts. If possible, do not make adjustments with the engine running.
- Keep all parts in good working condition and all hardware tightened. Replace all worn or damaged decals.

Toro Mower Safety

The following list contains safety information specific to Toro products and other safety information you must know.

This product is capable of amputating hands and feet and throwing objects. Always follow all safety instructions to avoid serious injury or death.

This product is designed for cutting and recycling grass or, when equipped with a grass bagger, for catching cut grass. Any use for purposes other than these could prove dangerous to user and bystanders.

General Operation

- Be sure the area is clear of other people before mowing. Stop the machine if anyone enters the area.
- Do not touch equipment or attachment parts which may be hot from operation. Allow to cool before attempting to maintain, adjust or service.
- Use only Toro approved attachments. Warranty may be voided if used with unapproved attachments.
- Check carefully for overhead clearances (i.e. branches, doorways, electrical wires) before operating under any objects and do not contact them.

Slope Operation

All slopes and ramps require extra caution. If you feel uneasy on a slope, do not mow it.

- Remove obstacles such as rocks, tree limbs, etc. from the mowing area.
- Watch for holes, ruts or bumps. Tall grass can hide obstacles.
- Use caution near drop-offs, ditches, or embankments. The machine could suddenly turn over if a wheel goes over the edge of a cliff or ditch, or if an edge caves in.
- Use extra care with grass catchers or other attachments. These can change the stability of the machine.
- Keep all movement on slopes slow and gradual. Do not make sudden changes in speed or direction.
- Mow slopes side to side.
- Do not mow slopes greater than 20 degrees.

Service

- Never store the machine or fuel container inside where there is an open flame, such as near a water heater or furnace.
- Keep nuts and bolts tight, especially the blade attachment bolts. Keep equipment in good condition.
- Never tamper with safety devices. Check safety systems for proper operation before each use.
- Use only genuine replacement parts to ensure that original standards are maintained.
- Check brake operation frequently. Adjust and service as required.

Slope Indicator

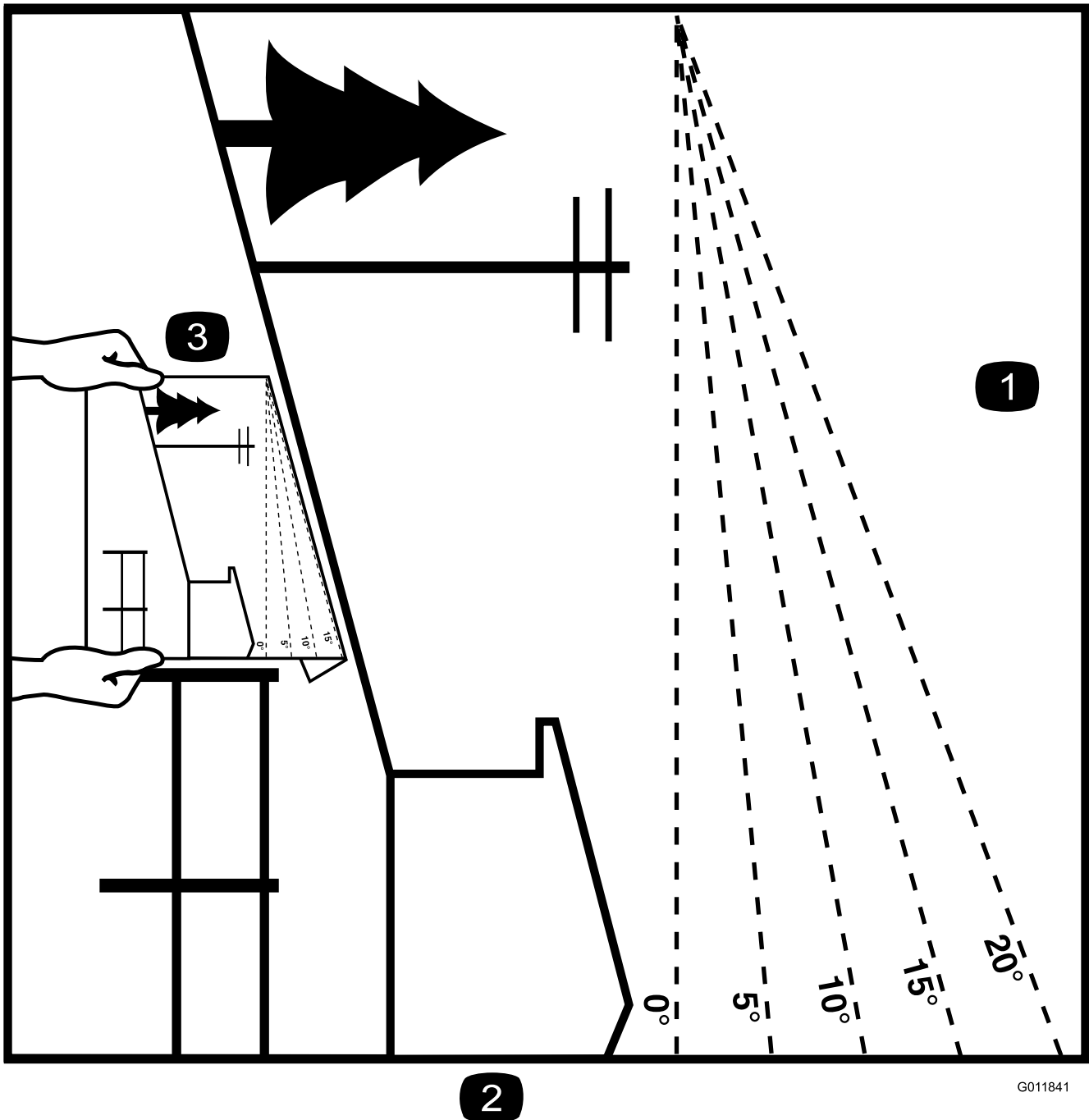

G011841

Figure 3

This page may be copied for personal use.

1. The maximum slope you can safely operate the machine on is **20 degrees**. Use the slope chart to determine the degree of slope of hills before operating. **Do not operate this machine on a slope greater than 20 degrees**. Fold along the appropriate line to match the recommended slope.
2. Align this edge with a vertical surface, a tree, building, fence pole, etc.
3. Example of how to compare slope with folded edge.

Safety and Instructional Decals



Safety decals and instructions are easily visible to the operator and are located near any area of potential danger. Replace any decal that is damaged or lost.



1-403005



82-2290



98-0776



52-2010



98-3256



66-1340



98-4387

1. Warning—wear hearing protection.



98-5954



68-8340



82-2280

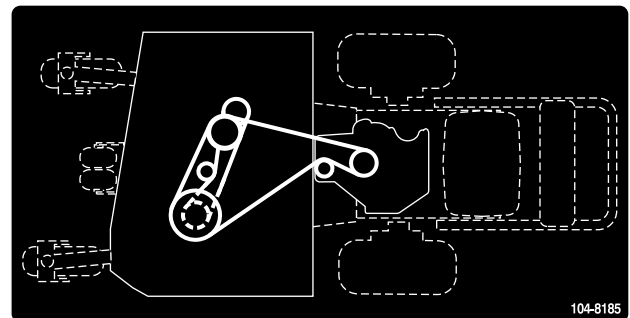

104-8185

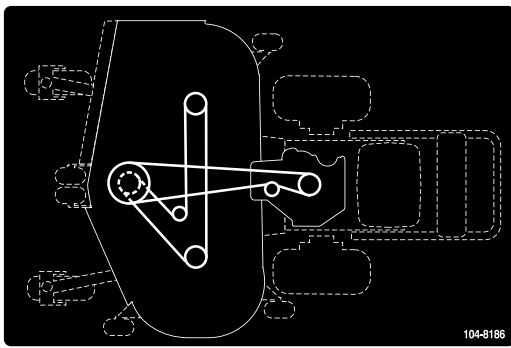

104-8186
48 inch mower

⚠ WARNING
OPERATE ONLY WITH DEFLECTOR OR CATCHER IN PLACE. READ OPERATOR'S MANUAL.

104-8569

ANTI-SCALP ROLLER ADJUSTMENT
FOR MAXIMUM DECK FLOTATION, PLACE ROLLERS IN POSITIONS SHOWN.
TURN ENGINE OFF BEFORE MAKING ROLLER ADJUSTMENTS.

- ————— 1.5"/38mm
- ————— 2.0"/51mm
- ————— 2.5"/63mm
- ————— 3.0"/76mm

105-7798



106-0699

⚠ DANGER AVOID SERIOUS INJURY or DEATH:

- DO NOT MOW WHEN CHILDREN OR OTHERS ARE AROUND.
- DO NOT ALLOW OPERATION OF THE MACHINE BY UNTRAINED PERSONNEL.
- KEEP SAFETY DEVICES (GUARDS, SHIELDS, ETC.) IN PLACE & WORKING.
- REMOVE OBJECTS THAT COULD BE THROWN BY THE BLADE.
- READ THE OPERATOR'S MANUAL FOR REPLACEMENT MANUAL, SEND MODEL AND SERIAL NUMBER TO: THE TORO CO., 8111 LYNDALE AVE. S., BLOOMINGTON, MN 55420-1196

105-0884

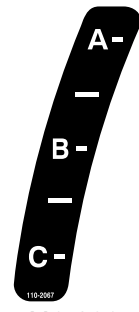

110-2067

ADJUSTABLE BAFFLE
BAFLE AJUSTABLE

A -	• Short, light grass • Dry conditions • Maximum dispersion			• Césped corto y ligero • Condiciones secas • Maxima dispersion
B -	• Bagging setting			• Posición para usar con bolsa
C -	• Tall, dense grass • Wet conditions • Maximum ground speed			• Césped alto y denso • Condiciones mojadas • Maxima velocidad

110-2068

1. Read the *Operator's Manual*.

CALIFORNIA SPARK ARRESTER WARNING
Operation of this equipment may create sparks that can start fires around dry vegetation. A spark arrester may be required. The operator should contact local fire agencies for laws or regulations relating to fire prevention requirements.

117-2718

HEIGHT OF CUT PINS ADJUSTMENT

- POSITION ALL PINS IN SAME HEIGHT OF CUT HOLE
- TURN ENGINE OFF BEFORE ADJUSTING DECK CUTTING HEIGHT
- NOTE: HEIGHT IS BASED ON USING ONE FRONT SPACER AND ONE REAR SPACER ON ADJUSTMENT PINS
- ADD ONE ADDITIONAL SPACER TO INCREASE CUTTING HEIGHT 1/4 INCH
- NOTE: REFER TO OPERATOR'S MANUAL FOR ADDITIONAL HEIGHT OF CUT ADJUSTMENT.

106-0635



105-0884

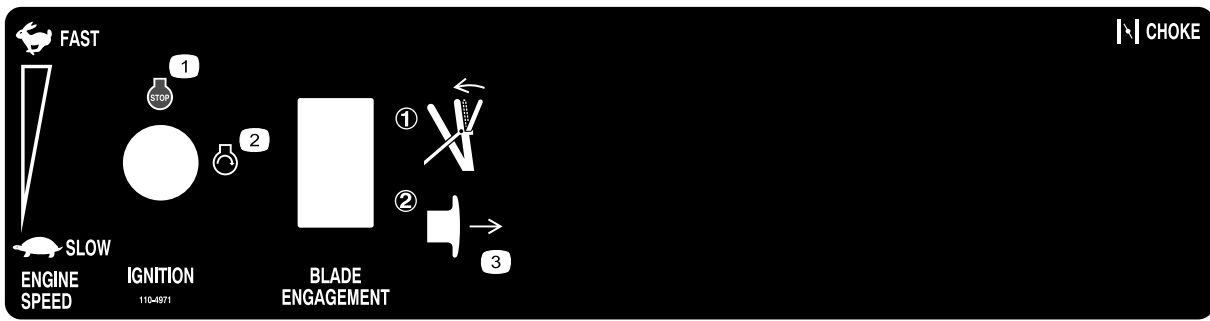

110-4971

1. Engine—stop
2. Engine—Start
3. Engage bale then pull out on the PTO to engage the blade.

Product Overview

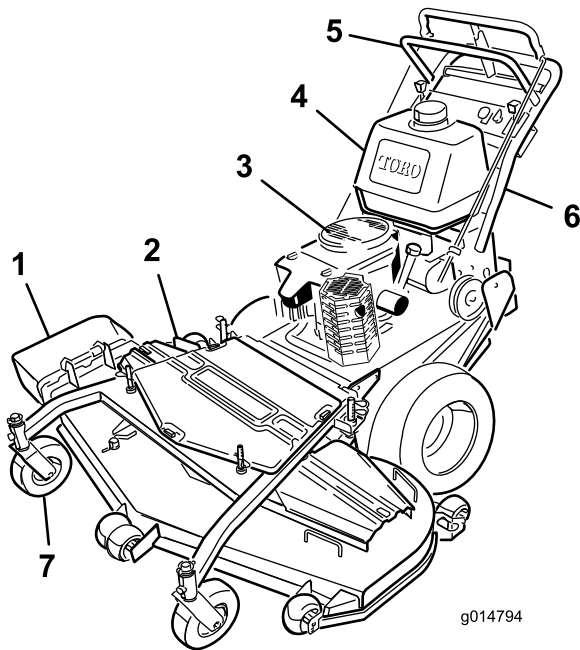

Figure 4

- | | |
|-------------------------|-----------------|
| 1. Side discharge chute | 5. Controls |
| 2. Mower deck | 6. Handle |
| 3. Recoil starter | 7. Caster wheel |
| 4. Gas tank | |

Controls

Become familiar with all the controls (Figure 5) before you start the engine and operate the machine.

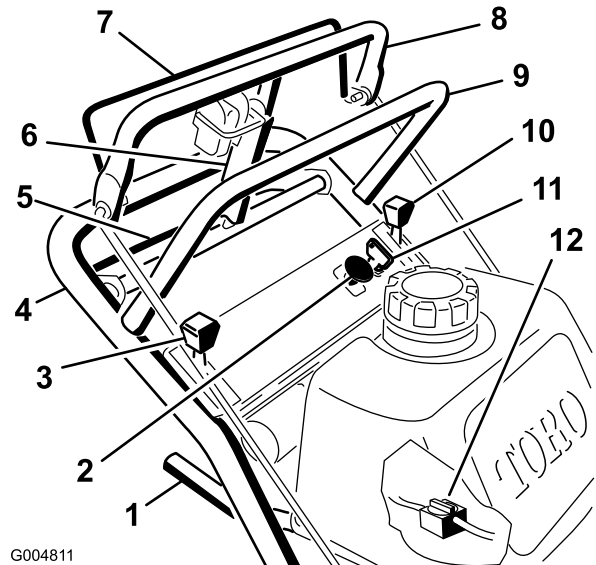

Figure 5

- | | |
|--------------------------------|---|
| 1. Gear shift lever | 7. Blade control bail |
| 2. Power take off switch (PTO) | 8. Upper control bar |
| 3. Choke control | 9. Upper handle |
| 4. Lower handle | 10. Throttle control |
| 5. Lower control bar | 11. Ignition switch |
| 6. Parking brake | 12. Fuel shut-off valve lever-released position |

Throttle Control

The throttle control has two positions: **Fast** and **Slow**.

Choke

Use the choke to start a cold engine.

Blade Control Bail

The bail is used in conjunction with the power take off switch (PTO) to engage the clutch to drive the mower blades. Release the mower control bail to disengage the mower blades.

Power Take Off Switch (PTO)

This pull switch is used in conjunction with the blade control bail to engage the clutch to drive the mower blades.

Gear Shift Lever

The transmission has five forward speeds, neutral and reverse, and has an in-line shift pattern.

Important: Do not shift while unit is moving, as transmission damage may occur.

Upper Control Bar

Shift to the desired gear and push forward on the upper control bar to engage forward traction operation and pull back to brake forward movement. Pull back on right side of upper control bar to turn right and left side to turn left.

Lower Control Bar

Shift transmission to reverse and squeeze the lower control bar and handle together to engage rearward traction assist operation.

Parking Brake Lever

Pull back on upper control bar and swing brake lever up against the upper handle (Figure 5).

Ignition Switch

This switch is used in conjunction with recoil starter and has two positions: **Run** and **Off**.

Recoil Starter

Pull recoil starter handle to start engine (not shown in Figure 5).

Fuel Shut-off Valve

Close the fuel shut-off valve when transporting or storing mower.

Specifications

Note: Specifications and design are subject to change without notice.

36 inch mowers:

Width with deflector down	51–1/8 inches (130 cm)
Length	82–3/4 inches (210 cm)
Height with handle in lowest position	41–3/16 inches (105 cm)
Weight	588 lb (267 kg)

48 inch mowers:

Width with deflector down	63–1/2 inches (161 cm)
Length	82 inches (208 cm)
Height with handle in lowest position	41–3/16 inches (105 cm)
Weight	649 lb (294 kg)

Attachments/Accessories

A selection of Toro approved attachments and accessories are available for use with the machine to enhance and expand its capabilities. Contact your Authorized Service Dealer or Distributor or go to www.Toro.com for a list of all approved attachments and accessories.

Operation

Note: Determine the left and right sides of the machine from the normal operating position.

Adding Fuel

- For best results, use only clean, fresh, unleaded gasoline with an octane rating of 87 or higher ((R+M)/2 rating method).
- Oxygenated fuel with up to 10% ethanol or 15% MTBE by volume is acceptable.
- **Do Not** use ethanol blends of gasoline (such as E15 or E85) with more than 10% ethanol by volume. Performance problems and/or engine damage may result which may not be covered under warranty.
- **Do Not** use gasoline containing methanol.
- **Do Not** store fuel either in the fuel tank or fuel containers over the winter unless a fuel stabilizer is used.
- **Do Not** add oil to gasoline.

▲ DANGER

In certain conditions, gasoline is extremely flammable and highly explosive. A fire or explosion from gasoline can burn you and others and can damage property.

- Fill the fuel tank outdoors, in an open area, when the engine is cold. Wipe up any gasoline that spills.
- Never fill the fuel tank inside an enclosed trailer.
- Do not fill the fuel tank completely full. Add gasoline to the fuel tank until the level is 1/4 to 1/2 inch (6 to 13 mm) below the bottom of the filler neck. This empty space in the tank allows gasoline to expand.
- Never smoke when handling gasoline, and stay away from an open flame or where gasoline fumes may be ignited by a spark.
- Store gasoline in an approved container and keep it out of the reach of children. Never buy more than a 30-day supply of gasoline.
- Do not operate without entire exhaust system in place and in proper working condition.

▲ DANGER

In certain conditions during fueling, static electricity can be released causing a spark which can ignite the gasoline vapors. A fire or explosion from gasoline can burn you and others and can damage property.

- Always place gasoline containers on the ground away from your vehicle before filling.
- Do not fill gasoline containers inside a vehicle or on a truck or trailer bed because interior carpets or plastic truck bed liners may insulate the container and slow the loss of any static charge.
- When practical, remove gas-powered equipment from the truck or trailer and refuel the equipment with its wheels on the ground.
- If this is not possible, then refuel such equipment on a truck or trailer from a portable container, rather than from a gasoline dispenser nozzle.
- If a gasoline dispenser nozzle must be used, keep the nozzle in contact with the rim of the fuel tank or container opening at all times until fueling is complete.

▲ WARNING

Gasoline is harmful or fatal if swallowed. Long-term exposure to vapors can cause serious injury and illness.

- Avoid prolonged breathing of vapors.
- Keep face away from nozzle and gas tank or conditioner opening.
- Keep gas away from eyes and skin.

Using Stabilizer/Conditioner

Use a fuel stabilizer/conditioner in the machine to provide the following benefits:

- Keeps gasoline fresh during storage of 90 days or less. For longer storage it is recommended that the fuel tank be drained.
- Cleans the engine while it runs
- Eliminates gum-like varnish buildup in the fuel system, which causes hard starting

Important: Do not use fuel additives containing methanol or ethanol.

Add the correct amount of gas stabilizer/conditioner to the gas.

Note: A fuel stabilizer/conditioner is most effective when mixed with fresh gasoline. To minimize the chance of varnish deposits in the fuel system, use fuel stabilizer at all times.

Filling the Fuel Tank

1. Shut the engine off and set the parking brake.
2. Clean around each fuel tank cap and remove the cap.
3. Add unleaded regular gasoline to both fuel tanks, until the level is 1/4 to 1/2 inch (6 mm to 13 mm) below the bottom of the filler neck.

This space in the tank allows gasoline to expand. Do not fill the fuel tanks completely full.

4. Install fuel tank caps securely.
5. Wipe up any gasoline that may have spilled.

Checking the Engine Oil Level

Before you start the engine and use the machine, check the oil level in the engine crankcase; refer to Checking Oil Level in Engine Maintenance (page 23)

Note: Determine the left and right sides of the machine from the normal operating position.

Think Safety First

Carefully read all the safety instructions and decals in the safety section. Knowing this information could help you or any bystanders avoid injury.

The use of protective equipment for eyes, hearing, feet and head is recommended.

⚠ CAUTION

This machine produces sound levels in excess of 85 dBA at the operator's ear and can cause hearing loss through extended periods of exposure.

Wear hearing protection when operating this machine.



Figure 6

1. Warning—wear hearing protection.

Using the Parking Brake

Stop on level ground, disengage drives, engage parking brake, shut off engine and remove key. Always set the parking brake when you stop the machine or leave it unattended.

Setting the Parking Brake

1. Pull the upper control bar (Figure 7) rearward and hold it in this position.

2. Lift the parking brake lock (Figure 7) up and gradually release the upper control bar. The brake lock should stay in the set (locked) position.

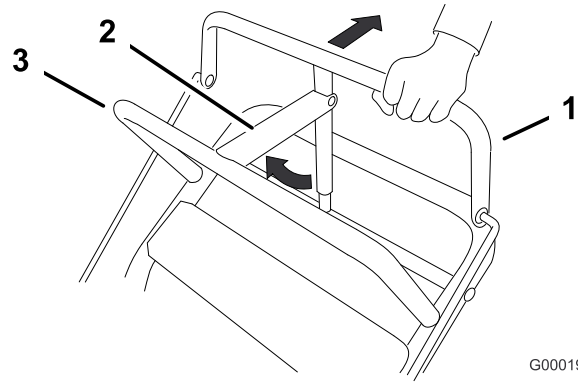

G000195

Figure 7

1. Upper control bar
2. Parking brake lever-set position
3. Fixed bar

Releasing the Parking Brake

1. Pull rearward on the upper control bar. Lower the parking brake lock to the released position.
2. Gradually release the upper control bar.

Starting and Stopping the Engine

Starting the Engine

1. Make sure spark plug wire(s) are installed on spark plug(s) and fuel valve is open.
2. Move the shift lever to neutral, set the parking brake and turn ignition key to run.
3. Move the throttle control to fast and move the choke lever to the on position before starting a cold engine.

Note: A warm or hot engine usually does not require any choking. To start a warm engine, move throttle control to the **fast** position.

4. Grasp recoil starter handle firmly and pull out until positive engagement results; then pull handle vigorously to start engine and allow rope to recoil slowly.

Important: Do not pull recoil rope to its limit or let go of the starter handle when rope is pulled out because rope may break or recoil assembly may be damaged.

Stopping the Engine

1. Move the throttle lever to the **slow** position (Figure 8).
2. Let engine idle for 30 to 60 seconds before turning the ignition key to **off**.

- Turn the ignition key to **off** (Figure 8).

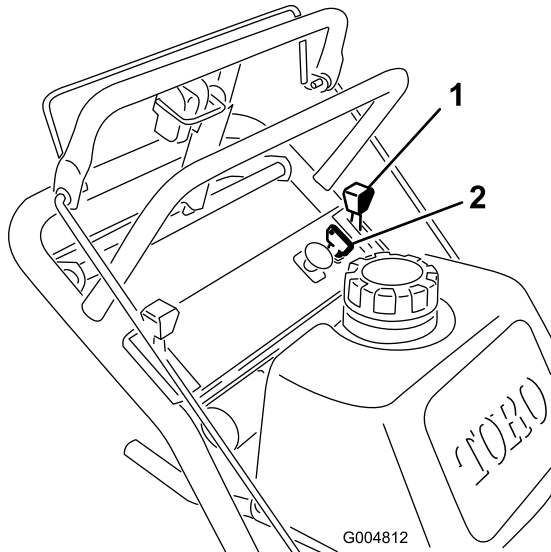

Figure 8

- Throttle lever
- Ignition key

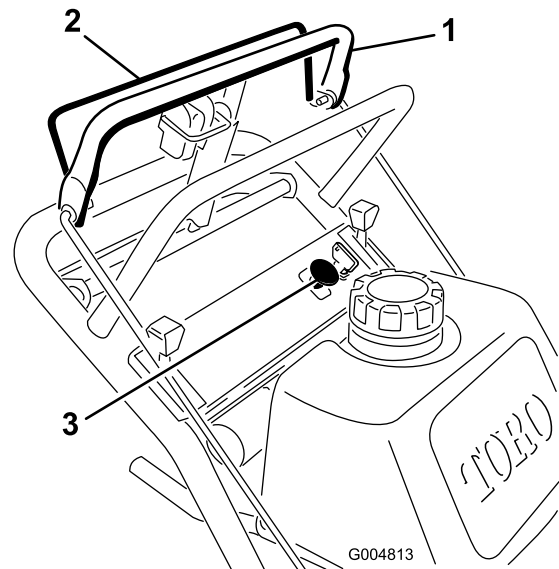

Figure 9

- Upper control bar
- Blade control bail
- Power take off switch (PTO)

- Set the parking brake and remove key.
- Pull the wire off spark plug(s) to prevent possibility of accidental starting before storing machine.
- Close the fuel shut off valve before storing machine.

Important: Make sure the fuel shut off valve is closed before transporting or storing machine, as fuel leakage may occur.

Operating the Mower Power Take Off (PTO)

The power take off switch (PTO) in conjunction with the blade control bail engages and disengages power to the electric clutch and mower blades.

Engaging the Mower Blades (PTO)

- Release the upper control bar to stop the machine (Figure 9).
- To engage the blades, squeeze blade control bail against the upper control bar (Figure 9).
- Pull the power take off switch (PTO) up and release. Hold the blade control bail against the upper control bar while operating.
- Repeat the procedure to engage the mower blades if the blade control bail is released.

Disengaging the Mower Blades (PTO)

Release the blade control bail to disengage the blades (Figure 9).

The Safety Interlock System

CAUTION

If the safety interlock switches are disconnected or damaged the machine could operate unexpectedly causing personal injury.

- Do not tamper with the interlock switches.
- Check the operation of the interlock switches daily and replace any damaged switches before operating the machine.

Understanding the Safety Interlock System

The safety interlock system is designed to prevent the mower blades from rotating unless:

- The control bail is pressed against the upper control bar.
- The power take off switch (PTO) is pulled **on**.

The safety interlock system is designed to stop the mower blades if you release the blade control bail.

Testing the Safety Interlock System

Service Interval: Before each use or daily

Test the safety interlock system before you use the machine each time.

Note: If the safety system does not operate as described below, have an Authorized Service Dealer repair the safety system immediately.

1. Set the parking brake and start the engine; refer to Starting and Stopping the Engine.
2. Squeeze the blade control bail against upper control bar. **The blades should not rotate.**
3. Then continue holding the blade control bail and pull up on the blade control switch and release. The clutch should engage and the mower blades begin rotating.
4. Release the blade control bail. **The blades should stop rotating.**
5. With the engine running, pull up the power take off switch (PTO) and release without holding the blade control bail. **The blades should not rotate.**

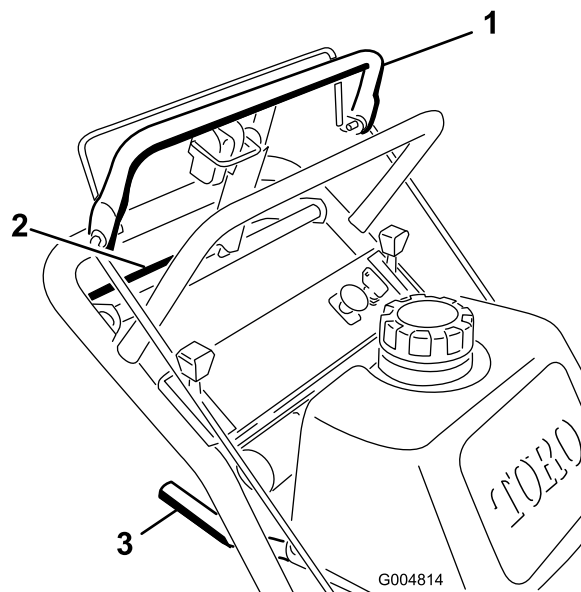

Figure 10

- | | |
|----------------------|----------------|
| 1. Upper control bar | 3. Shift lever |
| 2. Lower control bar | |

Driving Forward or Backward

The throttle control regulates the engine speed as measured in RPM (revolutions per minute). Place the throttle control in the **fast** position for best mowing performance.

Driving Forward

1. To go forward, move the shift lever to a forward gear (Figure 10).
2. Release the parking brake; refer to Releasing the Parking Brake in Operation.
3. Slowly press on the upper control bar to move forward (Figure 10).

To go straight, apply equal pressure to both ends of the upper control bar (Figure 10).

To turn, release pressure on the upper control bar side in the direction you want to turn (Figure 10).

Driving Backward

1. To go backward, move the shift lever to reverse gear.
2. Release the parking brake; refer to Releasing the Parking Brake.
3. Slowly squeeze the lower control bar and lower handle together to move rearward (Figure 10).

Using the Lower Control Bar

This procedure is for driving up a curb. This can be performed while driving forward or backward.

Note: Some curbs do not allow the rear drive tires to contact the curb. If this happens, drive the machine up the curb at an angle.

▲ WARNING

A blade can be bent or damaged when driving up a curb. Pieces of blade that may be thrown could seriously injure or kill you or bystanders.

Do not run blades while driving up a curb forward or backward.

Driving Forward Up a Curb

1. Disengage the mower blades.
2. Select first gear to drive the machine.
3. Drive machine until the castor wheels contact the curb (Figure 11).
4. Lift the front of the machine by pushing down on the lower handle (Figure 11).

5. Drive the machine until drive wheels contact the curb (Figure 11).
6. Lower the front of the machine (Figure 11).

Note: Both drive wheels should contact the curb and caster wheels straight.

7. At the same time, engage the lower control bar and lift up on the lower handle to drive over the curb (Figure 10 and Figure 11).

Note: Lifting up on the lower handle will assist driving the machine up a curb and not spin the drive wheels.

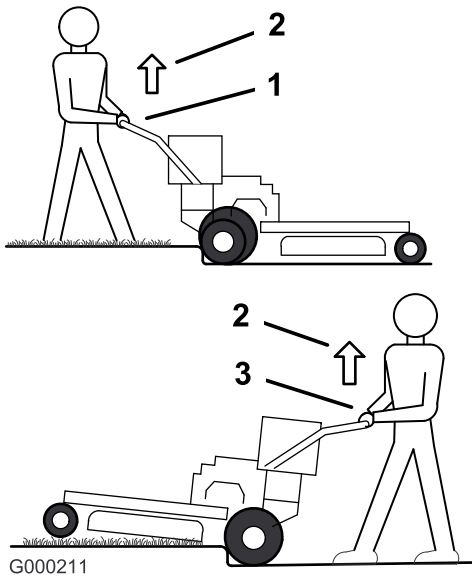

Figure 11

- | | |
|--|---|
| <ol style="list-style-type: none"> 1. Lower Control Bar engaged and mower in reverse. 2. Pull up to assist machine | <ol style="list-style-type: none"> 3. Lower Control Bar engaged and mower going forward. |
|--|---|

Driving Backward Up a Curb

1. Disengage the mower blades.
2. Select reverse to drive machine.
3. Drive the machine until drive wheels contact curb (Figure 11).

Note: Both drive wheels should contact the curb and caster wheels straight.

4. At the same time engage lower control bar and lift up on the lower handle (Figure 10 and Figure 11).

Note: Lifting up on the lower handle will assist driving the machine up a curb and not spin the drive wheels.

Stopping the Machine

To stop the machine, pull back on the upper control bar, release the blade control bail, and turn the ignition key to off. Also set the parking brake if you leave the machine unattended; refer to Setting the Parking Brake in (page). Remember to remove the key from the ignition switch.

⚠ CAUTION

Children or bystanders may be injured if they move or attempt to operate the machine while it is unattended.

Always remove the ignition key and set the parking brake when leaving the machine unattended, even if just for a few minutes.

Transporting Machines

Use a heavy-duty trailer or truck to transport the machine. Ensure that the trailer or truck has all necessary brakes, lighting, and marking as required by law. Please carefully read all the safety instructions. Knowing this information could help you, your family, pets or bystanders avoid injury.

To transport the machine:

1. If using a trailer, connect it to the towing vehicle and connect the safety chains.
2. If applicable, connect the trailer brakes.
3. Load the machine onto the trailer or truck.
4. Stop the engine, remove the key, set the brake, and close the fuel valve.
5. Use the metal tie down loops on the machine to securely fasten the machine to the trailer or truck with straps, chains, cable, or ropes (Figure 12).

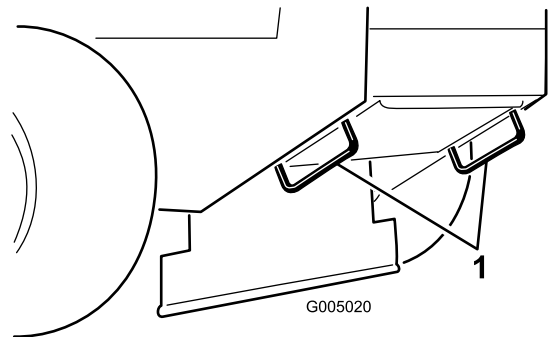

Figure 12

1. Traction unit tie down loop

Side Discharging or Mulching the Grass

This mower has a hinged grass deflector that disperses clippings to the side and down toward the turf.

⚠ DANGER

Without the grass deflector, discharge cover, or complete grass catcher assembly mounted in place, you and others are exposed to blade contact and thrown debris. Contact with rotating mower blade(s) and thrown debris will cause injury or death.

- Never remove the grass deflector from the mower because the grass deflector routes material down toward the turf. If the grass deflector is ever damaged, replace it immediately.
- Never put your hands or feet under the mower.
- Never try to clear discharge area or mower blades unless you release the bail and the power take off (PTO) is off. Rotate the ignition key to Off. Also remove the key and pull the wire(s) off the spark plug(s).

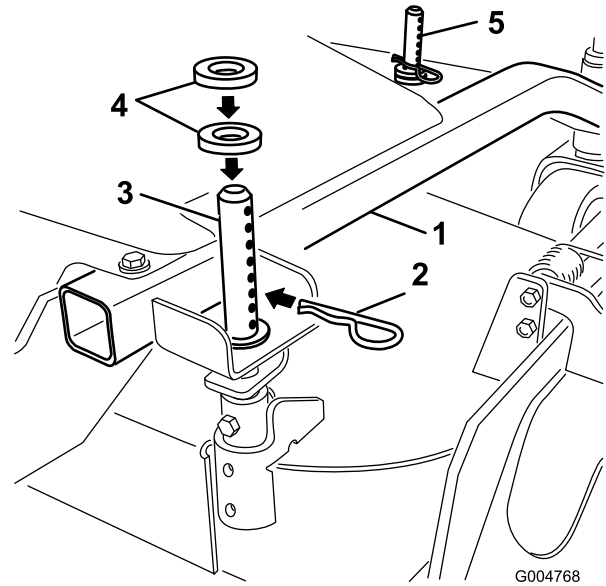

Figure 13

1. Carrier Frame
2. Hairpin Cotter
3. Back height-of-cut post
4. Spacers
5. Front height-of-cut post

Adjusting the Height-of-Cut

The height-of-cut can be adjusted from 1 to 4-1/2 inches (25 to 114 mm) in 1/4 inch (6 mm) increments. Adjustment is done by relocating four hairpin cotter pins in different hole locations and by adding or removing spacers.

Note: All height-of-cut pins need at least one spacer or damage can occur to the bushing if none are used.

Note: All height-of-cut pins can use two spacers maximum.

1. Select hole in height-of-cut post and number of spacers corresponding to the height-of-cut desired (Figure 13).
2. Using the lift handle, raise side of deck and remove hairpin cotter (Figure 13).
3. Add or remove spacers if needed and then align the holes and insert the hairpin cotter (Figure 13).

Note: Spare height-of-cut spacers may be stored on posts and retained by a hairpin cotter.

Important: All four hairpin cotter pins must be in the same hole location and with the correct number of spacers for a level cut.

Adjusting the Anti-Scalp Rollers

The anti-scalp rollers need to be adjusted in the proper hole location for each height-of-cut position. There needs to be 3/8 inch (10 mm) minimum clearance above the ground.

Note: If the anti-scalp rollers are adjusted too low, it can cause excess wear of the rollers.

1. After adjusting the height-of-cut, check the anti-scalp rollers so that there is a minimum of 3/8 inch (10 mm) clearance above the ground (Figure 14, Figure 15, Figure 16).
2. If adjustment is needed, remove the bolt, washers and nut (Figure 14, Figure 15, Figure 16).
3. Select a hole position so the anti-scalp rollers are a minimum of 3/8 inch (10 mm) off the ground (Figure 14, Figure 15, Figure 16).
4. Install the bolt and nut (Figure 14, Figure 15, Figure 16).

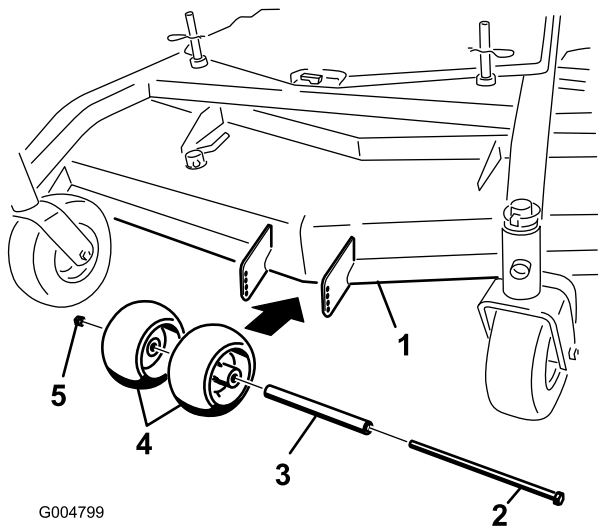

Figure 14
48 inch Mower Decks

- | | |
|---------------|-----------------------|
| 1. Mower deck | 4. Anti-scalp rollers |
| 2. Bolt | 5. Nut |
| 3. Spacer | |

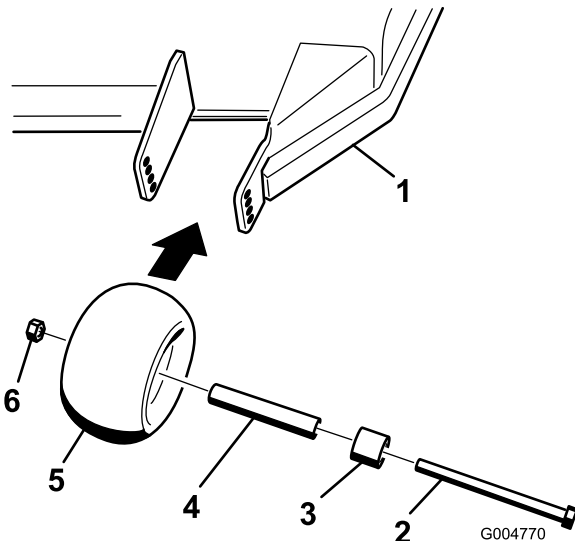

Figure 15
48 inch Mower Decks

- | | |
|---------------|-----------------------|
| 1. Mower deck | 4. Bushing |
| 2. Bolt | 5. Anti-scalp rollers |
| 3. Spacer | 6. Nut |

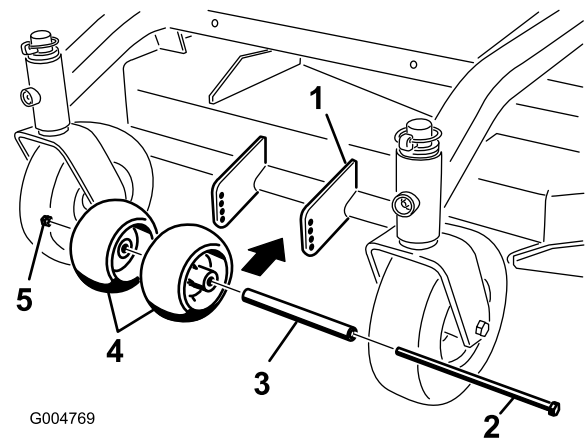

Figure 16
36 inch Mower Deck

- | | |
|---------------|-----------------------|
| 1. Mower deck | 4. Anti-scalp rollers |
| 2. Bolt | 5. Nut |
| 3. Spacer | |

- In certain mowing conditions and terrain, a mismatch of cutting height may be seen. Adjusting the outside anti-scalp rollers to the minimum setting of 3/8 inch (10 mm) will help prevent the mower deck cutting too low on the outside and minimize the mismatch.

Adjusting the Handle Height

The handle position can be adjusted to match the operator's height preference.

- Remove the hairpin cotter, washer and clevis pin securing control rod fitting to the idler bracket (Figure 17).

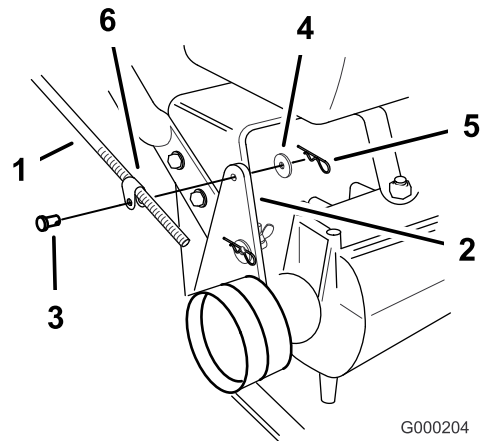

Figure 17

- | | |
|----------------------------|-------------------|
| 1. Control rod and fitting | 4. Washer |
| 2. Idler bracket | 5. Hairpin cotter |
| 3. Clevis pin | 6. Rod fitting |

- Loosen the upper flange bolts (3/8 x 1 inch) and the flange nut securing the handle to the rear frame (Figure 18).

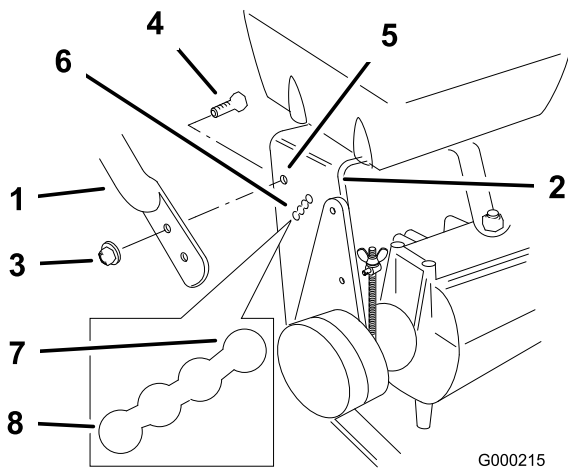

Figure 18

- | | |
|--------------------------------|-------------------------|
| 1. Upper handle | 5. Upper mounting hole |
| 2. Rear frame | 6. Lower mounting holes |
| 3. Flange nut, (3/8 inch) | 7. Low position |
| 4. Flange bolt, (3/8 x 1 inch) | 8. High position |

3. Remove the lower flange bolts (3/8 x 1 inch) and flange nuts securing the handle to the rear frame (Figure 18).
4. Pivot the handle to the desired operating position and install the lower flange bolts (3/8 x 1 inch) and the flange nuts into the mounting holes. Tighten all flange bolts.
5. Check the control bar for correct adjustment. Refer to Adjusting the Control Bar in the maintenance section.
6. Check the parking brake adjustment. Refer to Checking the Brakes in the maintenance section.

Adjusting the Flow Baffle

The mower discharge flow can be adjusted for different types of mowing conditions. Position the cam lock and baffle to give the best quality of cut.

1. Disengage the PTO, move the motion control levers to the neutral locked position and set the parking brake.
2. Stop the engine, remove the key, and wait for all moving parts to stop before leaving the operating position.
3. To adjust the baffle, loosen the nut (Figure 19).
4. Adjust the baffle and nut in the slot to the desired discharge flow and tighten the nut.

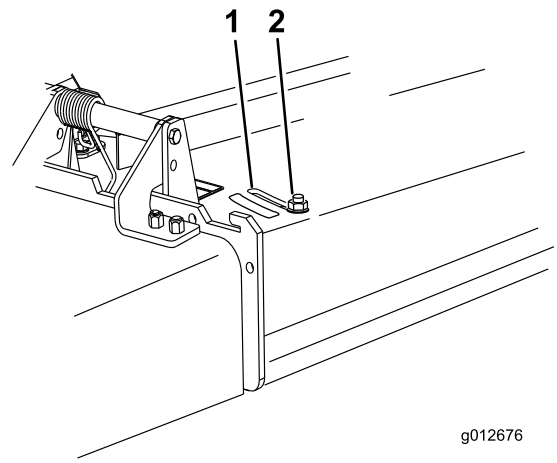

Figure 19

- | | |
|---------|--------|
| 1. Slot | 2. Nut |
|---------|--------|

Positioning the Flow Baffle

The following figures are only recommendations for use. Adjustments will vary by grass type, moisture content, and height of grass.

Note: If the engine power draws down and the mower ground speed is the same, open up the baffle.

Position A

This is the full rear position (see Figure 20). The suggested use for this position is as follows.

- Use for short, light grass mowing conditions.
- Use in dry conditions.
- For smaller grass clippings.
- Propels grass clippings farther away from the mower.

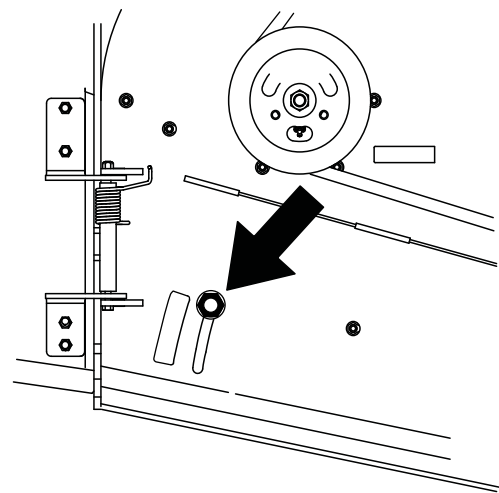

Figure 20

Position B

Use this position when bagging (Figure 21).

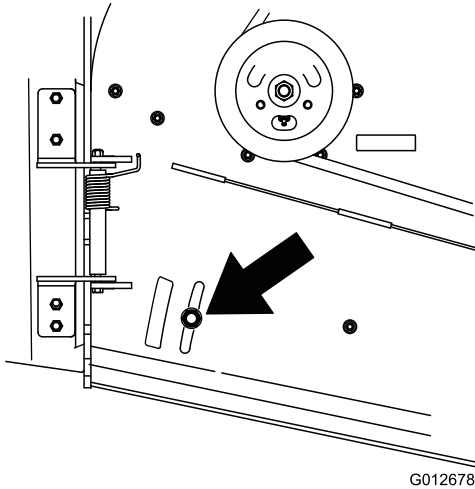

Figure 21

Position C

This is the full open position. The suggested use for this position is as follows (Figure 22).

- Use in tall, dense grass mowing conditions.
- Use in wet conditions.
- Lowers the engine power consumption.
- Allows increased ground speed in heavy conditions.

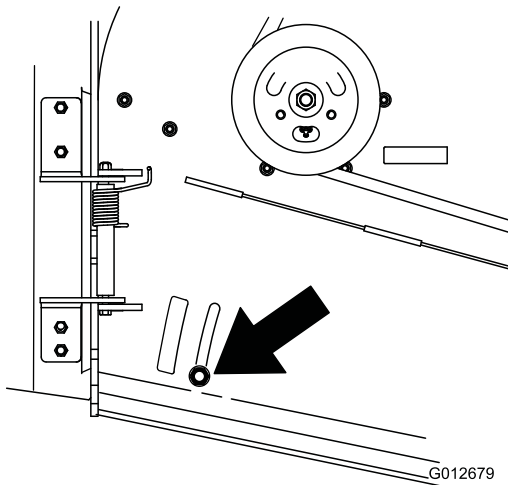

Figure 22

Using the Mid-Size Weight

Weights are installed on certain mowers to improve balance and improve performance. The weights can be moved or removed to create optimized performance under different mowing conditions and for operator preference (Figure 23 or Figure 24).

The following table indicates the position of the weight as installed at the factory.

Mower Deck Size	Number of weights install	Position of the weight
36 inches	none	none
48 inches	2	Rear

- Any rear weight must be removed when a Tru-Track® Sulky is installed.
- When a Tru-Track® Sulky is installed front weights are needed. Contact an Authorized Service Dealer for the correct quantity of weights and placement.

▲ WARNING

The front end of the machine can rapidly rise up when the mower is removed. This could cause serious injury to you or bystanders.

Support the rear of the machine when removing the mower form the carrier frame.

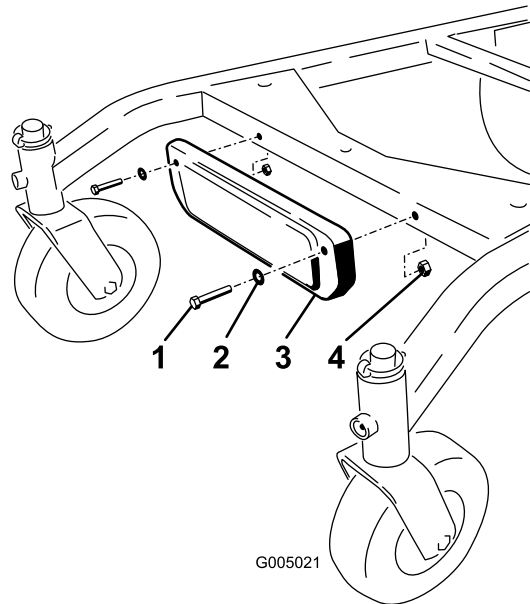

Figure 23
Installing the front weight.

- | | |
|-----------|-----------|
| 1. Bolt | 3. Weight |
| 2. Washer | 4. Nut |

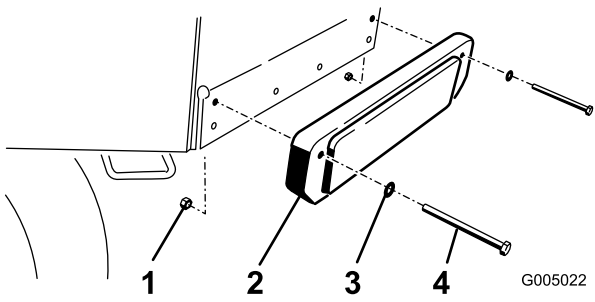

Figure 24

Installing the rear weight.

- 1. Nut
 - 2. Weight
 - 3. Washer
 - 4. Bolt
-

Maintenance

Note: Determine the left and right sides of the machine from the normal operating position.

Recommended Maintenance Schedule(s)

Maintenance Service Interval	Maintenance Procedure
After the first 8 hours	<ul style="list-style-type: none">• Change the engine oil.
Before each use or daily	<ul style="list-style-type: none">• Check the safety interlock system.• Grease the caster wheels and caster pivot.• Check the engine oil level.• Clean the air intake screen.• Check the brakes on both a level surface and slope.• Inspect the blades.
Every 25 hours	<ul style="list-style-type: none">• Clean foam air cleaner element.
Every 50 hours	<ul style="list-style-type: none">• Grease the PTO belt idler.• Grease the mower deck belt idler.• Check the paper air cleaner element.• Check the tire pressure• Check the traction drive belt• Check the transmission belt.• Check the mower belt.• Check the PTO drive belt.
Every 100 hours	<ul style="list-style-type: none">• Change the engine oil.• Check the spark plugs.• Adjust the electric clutch.
Every 200 hours	<ul style="list-style-type: none">• Replace the paper air cleaner element.• Change the oil filter.• Replace the fuel filter.
Every 250 hours	<ul style="list-style-type: none">• Grease the transmission couplers (more often in dirty or dusty conditions).
Every 400 hours	<ul style="list-style-type: none">• Grease the front wheel bearings (more often in dirty or dusty conditions).
Before storage	<ul style="list-style-type: none">• Paint chipped surfaces.• Perform all maintenance procedures listed above before storage.

Important: Refer to your engine operator's manual for additional maintenance procedures.

⚠ CAUTION

If you leave the key in the ignition switch, someone could accidentally start the engine and seriously injure you or other bystanders.

Remove the key from the ignition and disconnect the spark plug wires from the spark plugs before you do any maintenance. Set the wires aside so that they do not accidentally contact the spark plugs.

Lubrication

Grease with No. 2 general purpose lithium base or molybdenum base grease.

How to Grease

1. Disengage the PTO and set the parking brake.
2. Stop the engine, remove the key, and wait for all moving parts to stop before leaving the operating position.
3. Clean the grease fittings with a rag. Make sure to scrape any paint off the front of the fitting(s).
4. Connect a grease gun to the fitting. Pump grease into the fittings until grease begins to ooze out of the bearings.
5. Wipe up any excess grease.

Lubricating the Caster and Wheel Bearings

Service Interval: Before each use or daily
Every 400 hours

1. Lubricate the front caster wheel bearings and front pivots (Figure 25).

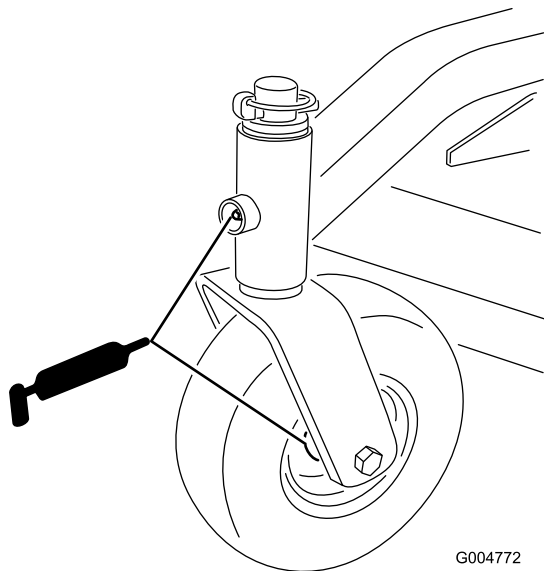

Figure 25

Note: Make sure the rear wheel grease caps are removed before lubricating rear wheels.

Greasing the Transmission Couplers

Service Interval: Every 250 hours

Lubricate the transmission couplers located in the back of the machine (Figure 26).

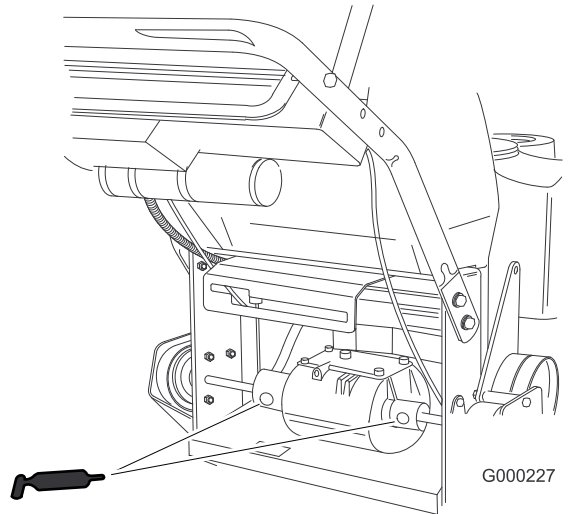

Figure 26

Greasing the PTO Drive Belt Idler and Mower Deck Belt Idler

Service Interval: Every 50 hours—Grease the PTO belt idler.

Every 50 hours—Grease the mower deck belt idler.

Grease the idler pulley pivots (Figure 27 or Figure 28).

Note: You will have to remove the carrier covers to access the grease fitting for the mower deck.

2. Raise the rear of the machine and use jack stands to support the machine.
3. Remove the rear wheel and tire assemblies.
4. Remove the rear wheel grease cap. Lubricate the rear wheel bearing (Figure 25).
5. Install the grease cap.
6. Install the rear wheel and tire assembly.

Engine Maintenance

Servicing the Air Cleaner

Service Interval/Specification

Service Interval: Every 25 hours—Clean foam air cleaner element.

Every 50 hours—Check the paper air cleaner element.

Every 200 hours—Replace the paper air cleaner element.

Note: Service the air cleaner more frequently (every few operating hours) if the operating conditions are extremely dusty or sandy.

Important: Do not oil the foam or paper element.

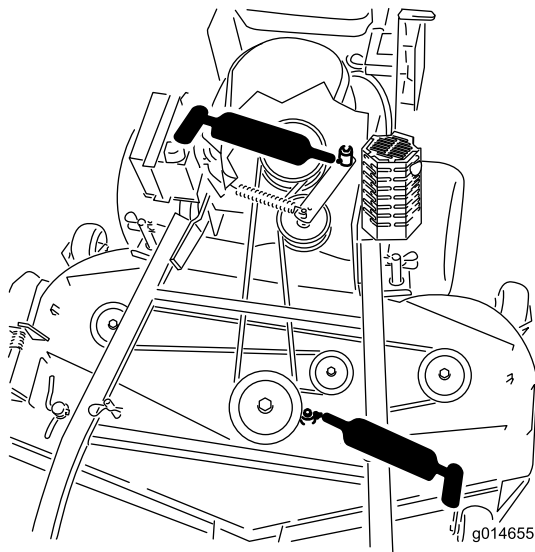

Figure 27
48 inch Mower Deck shown

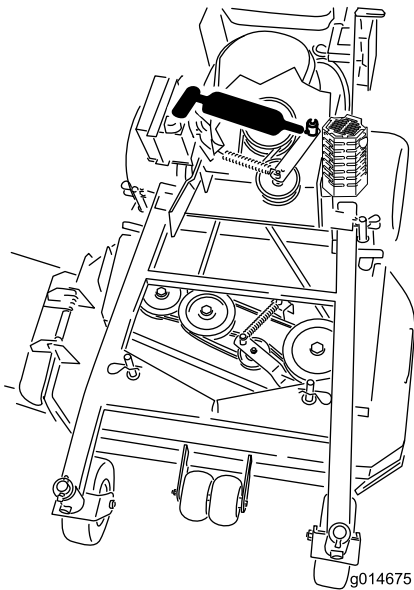

Figure 28
36 inch Mower Deck shown

Removing the Foam and Paper Elements

1. Disengage the PTO and set the parking brake.
2. Stop the engine, remove the key, and wait for all moving parts to stop before leaving the operating position.
3. Clean around the air cleaner to prevent dirt from getting into the engine and causing damage (Figure 29).

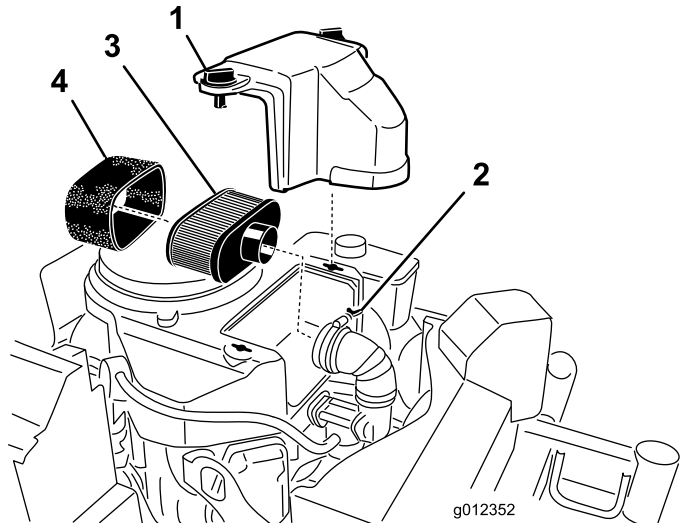

Figure 29

- | | |
|---------------|------------------|
| 1. Cover | 3. Paper element |
| 2. Hose clamp | 4. Foam element |

4. Unscrew the cover knobs and remove the air cleaner cover (Figure 29).
5. Unscrew the hose clamp and remove the air cleaner assembly (Figure 29).
6. Carefully pull the foam element off the paper element (Figure 29).

Cleaning the Foam Air Cleaner Element

1. Wash the foam element in liquid soap and warm water. When the element is clean, rinse it thoroughly.
2. Dry the element by squeezing it in a clean cloth.

Important: Replace the foam element if it is torn or worn.

Servicing the Paper Air Cleaner Element

1. Do not clean the paper filter, replace it (Figure 29).
2. Inspect the element for tears, an oily film, or damage to the rubber seal.
3. Replace the paper element if it is damaged.

Installing the Foam and Paper Elements

Important: To prevent engine damage, always operate the engine with the complete foam and paper air cleaner assembly installed.

1. Carefully slide the foam element onto the paper air cleaner element (Figure 29).
2. Place the air cleaner assembly onto the air cleaner base and secure it with the 2 wing nuts (Figure 29).
3. Place the air cleaner cover into position and tighten the cover knob (Figure 29).

Servicing the Engine Oil

Service Interval/Specification

Service Interval: Before each use or daily—Check the engine oil level.

After the first 8 hours—Change the engine oil.

Every 100 hours—Change the engine oil.

Every 200 hours—Change the oil filter.

Note: Change the oil more frequently when the operating conditions are extremely dusty or sandy.

Oil Type: Detergent oil (API service SF, SG, SH, SJ or SL)

Crankcase Capacity: 58 ounces (1.7 liter) with the filter removed; 51 ounces (1.5 liter) without the filter removed

Viscosity: Refer to the table (Figure 30).

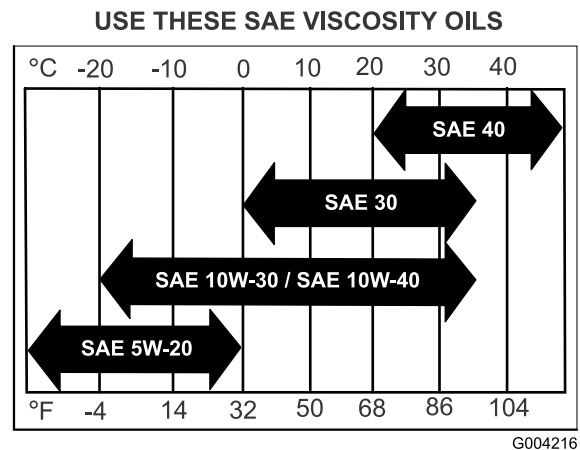

Figure 30

Checking the Engine Oil Level

1. Park the machine on a level surface.
2. Disengage the PTO and set the parking brake.
3. Stop the engine, remove the key, and wait for all moving parts to stop before leaving the operating position.
4. Clean around the oil dipstick (Figure 31) so that dirt cannot fall into the filler hole and damage the engine.

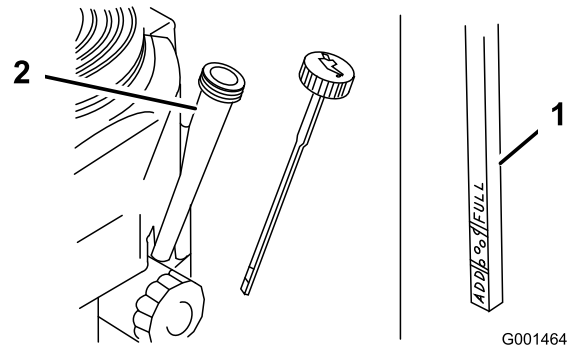

Figure 31

1. Oil dipstick
2. Filler tube

5. Unscrew the oil dipstick and wipe the end clean (Figure 31).
6. Slide the oil dipstick fully into the filler tube, but do not thread onto tube (Figure 31).
7. Pull the dipstick out and look at the end. If the oil level is low, slowly pour only enough oil into the filler tube to raise the level to the Full mark.

Important: Do not overfill the crankcase with oil and run the engine; engine damage can result.

Changing the Engine Oil

1. Park the machine so that the drain side is slightly lower than the opposite side to assure the oil drains completely.
2. Disengage the PTO and set the parking brake.
3. Stop the engine, remove the key, and wait for all moving parts to stop before leaving the operating position.
4. Slide the drain hose over the oil drain valve.
5. Place a pan below the drain hose. Rotate oil drain valve to allow oil to drain (Figure 32).
6. When oil has drained completely, close the drain valve.
7. Remove the drain hose (Figure 32).

Note: Dispose of the used oil at a recycling center.

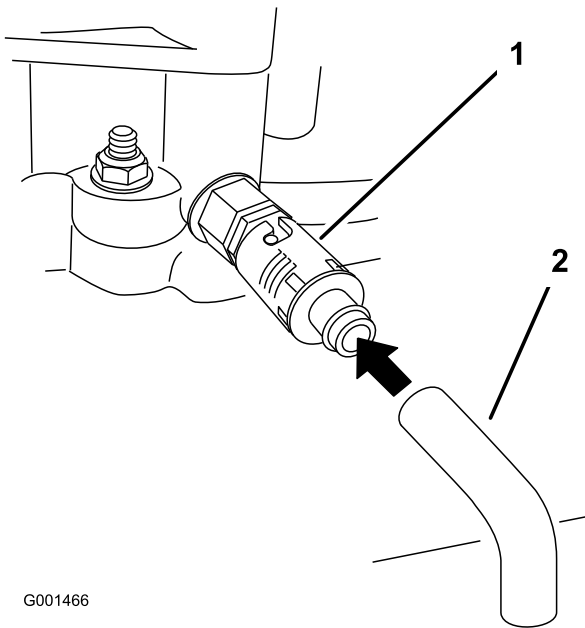

Figure 32

1. Oil drain valve
2. Oil drain hose

8. Slowly pour approximately 80% of the specified oil into the filler tube (Figure 31).
9. Check the oil level; refer to Checking the Engine Oil Level.
10. Slowly add the additional oil to bring it to the **Full** mark.

Changing the Oil Filter

Note: Change the oil filter more frequently when the operating conditions are extremely dusty or sandy.

1. Drain the oil from the engine; refer to Changing the Engine Oil.
2. Remove the old filter (Figure 33).

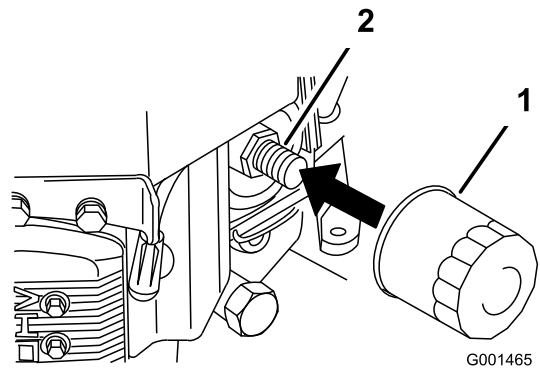

Figure 33

1. Oil filter
2. Adapter

3. Apply a thin coat of new oil to the rubber gasket on the replacement filter (Figure 33).
4. Install the replacement oil filter to the filter adapter, turn the oil filter clockwise until the rubber gasket contacts the filter adapter, then tighten the filter an additional 3/4 turn (Figure 33).
5. Fill the crankcase with the proper type of new oil; refer to Servicing the Engine Oil.
6. Run the engine for about 3 minutes, stop the engine, and check for oil leaks around the oil filter and drain valve.
7. Check the engine oil level and add oil if needed.
8. Wipe up any spilled oil.

Servicing the Spark Plugs

Service Interval/Specification

Service Interval: Every 100 hours—Check the spark plugs.

Ensure that the air gap between the center and side electrodes is correct before installing the spark plug. Use a spark plug wrench for removing and installing the spark plugs and a gapping tool/feeler gauge to check and adjust the air gap. Install a new spark plug if necessary.

Type: Champion® RCJ8Y or equivalent **Air Gap:** 0.030 inch (0.75 mm)

Removing the Spark Plugs

1. Disengage the PTO and set the parking brake.
2. Stop the engine, remove the key, and wait for all moving parts to stop before leaving the operating position.
3. Disconnect the wires from the spark plugs (Figure 34).

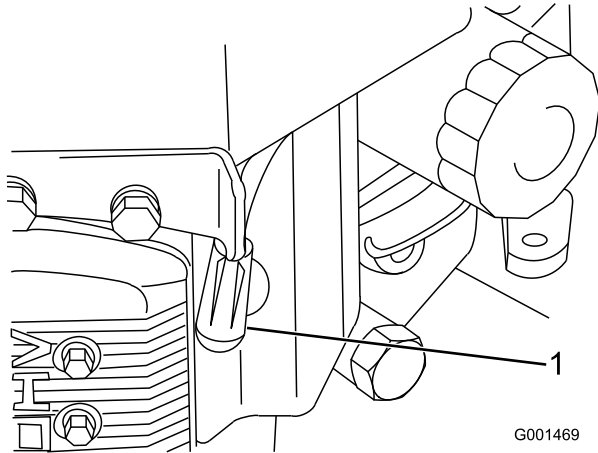

Figure 34

1. Spark-plug wire/spark plug

4. Clean around the spark plugs to prevent dirt from falling into the engine and potentially causing damage.
5. Remove the spark plugs and the metal washers.

Checking the Spark Plugs

1. Look at the center of the spark plugs (Figure 35). If you see light brown or gray on the insulator, the engine is operating properly. A black coating on the insulator usually means that the air cleaner is dirty.
2. If needed, clean the spark plug with a wire brush to remove carbon deposits.

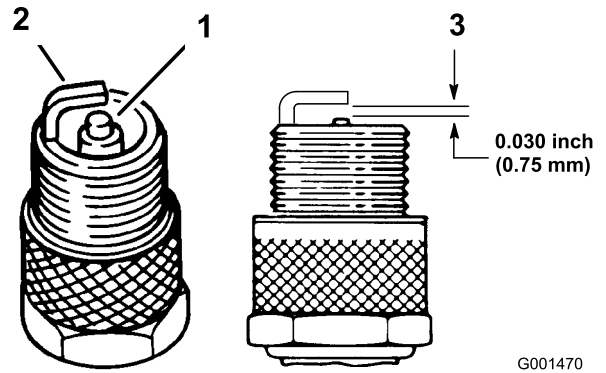

Figure 35

1. Center electrode insulator
2. Side electrode
3. Air gap (not to scale)

Important: Always replace the spark plugs when it has worn electrodes, an oily film on it, or has cracks in the porcelain.

3. Check the gap between the center and side electrodes (Figure 35). Bend the side electrode (Figure 35) if the gap is not correct.

Installing the Spark Plugs

1. Install the spark plugs and the metal washer. Ensure that the air gap is set correctly.
2. Tighten the spark plugs to 16 ft-lb (22 N-m).
3. Connect the wires to the spark plugs (Figure 35).

Fuel System Maintenance

Draining the Fuel Tank

⚠ DANGER

In certain conditions, gasoline is extremely flammable and highly explosive. A fire or explosion from gasoline can burn you and others and can damage property.

- Drain gasoline from the fuel tank when the engine is cold. Do this outdoors in an open area. Wipe up any gasoline that spills.
- Never smoke when draining gasoline, and stay away from an open flame or where a spark may ignite the gasoline fumes.

1. Park the machine on a level surface, to ensure the fuel tank drains completely. Then disengage the power take off (PTO), set the parking brake, and turn the ignition key to **off**. Remove the key.
2. Close the fuel shut-off valve at the fuel tank (Figure 36).
3. Squeeze the ends of the hose clamp together and slide it up the fuel line away from fuel filter (Figure 36).
4. Pull the fuel line off the fuel filter (Figure 36). Open the fuel shut-off valve and allow the gasoline to drain into a gas can or drain pan.

Note: Now is the best time to install a new fuel filter because the fuel tank is empty. Refer to Replacing the Fuel Filter.

5. Install the fuel line onto the fuel filter. Slide the hose clamp close to the valve to secure the fuel line.

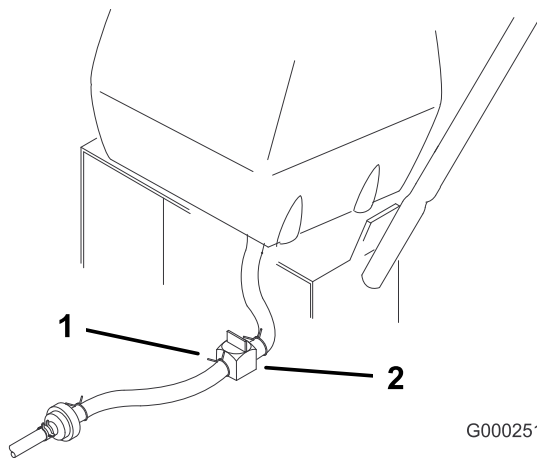

Figure 36

1. Fuel shut-off valve
2. Clamp

Replacing the Fuel Filter

Service Interval: Every 200 hours

Never install a dirty filter if it is removed from the fuel line.

Note: Note how the fuel filter is installed.

Note: Wipe up any spilled fuel.

1. Disengage the PTO and set the parking brake.
2. Stop the engine, remove the key, and wait for all moving parts to stop before leaving the operating position.
3. Close fuel shut-off valve at fuel tank (Figure 36).

Note: Remove the fuel line from the fuel valve that is closest to the engine.

4. Squeeze the ends of the hose clamps together and slide them away from the filter (Figure 37).

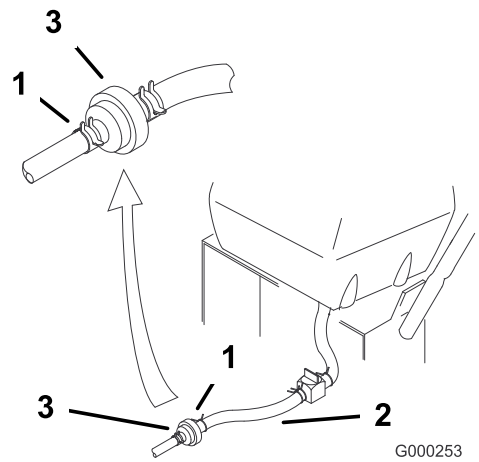

Figure 37

1. Hose clamp
2. Fuel line
3. Filter

5. Remove the filter from the fuel lines.
6. Install a new filter and move the hose clamps close to the filter.
7. Open fuel shut-off valve at fuel tank (Figure 36).
8. Check for fuel leaks and repair if needed.

Electrical System Maintenance

Servicing the Fuse

The electrical system is protected by a fuse. It requires no maintenance. If the fuse blows, check the component or circuit for malfunction or a short. To replace the fuse, pull out on the fuse (Figure 38) to remove or replace it.

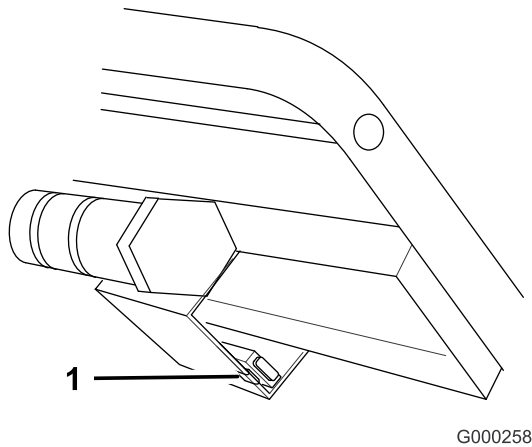

Figure 38

1. Fuse, 7.5 amp, blade type

Drive System Maintenance

Adjusting the Control Bar

1. Check the gap between upper control bar and fixed bar with wheel drive fully engaged. The gap should be approximately 1 to 1-1/4 inch (25-32 mm) (Figure 39).

Note: The upper control bar and fixed bar must be parallel when the upper control bar is in the engaged, drive, neutral, or brake positions.

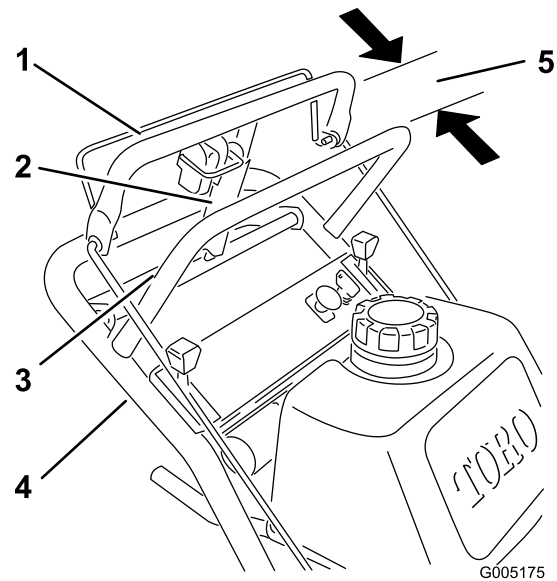

Figure 39

- | | |
|------------------------|----------------------------------|
| 1. Upper control bar | 4. Handle |
| 2. Parking brake lever | 5. 1 to 1-1/4 inch (25-32mm) gap |
| 3. Fixed control bar | |

2. Check the operation. If adjustment is required, remove hairpin cotter, washer and clevis pin securing control rod fitting to idler bracket (Figure 40).
3. Thread the rod fitting up or down on the rod until the proper position is attained and install the rod fitting to the idler bracket with the clevis pin, washer and hairpin cotter.

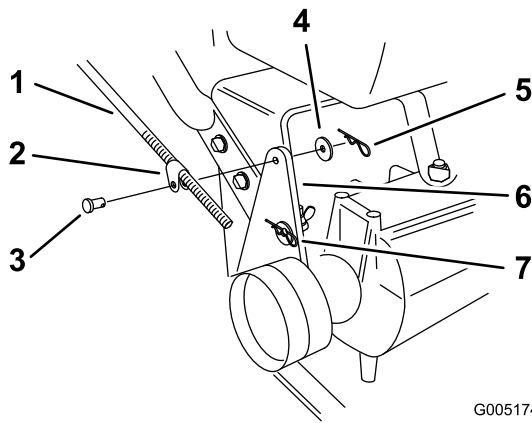

Figure 40

G005174

- | | |
|----------------------------|-----------------------|
| 1. Control rod and fitting | 5. Washer |
| 2. 3-1/2 inch (89 mm) | 6. Hairpin cotter pin |
| 3. Idler bracket | 7. Rod fitting |
| 4. Clevis pin | 8. Hole F |

Checking the Tire Pressure

Service Interval: Every 50 hours/Monthly (whichever comes first)—Check the tire pressure

Check the pressure at the valve stem (Figure 41).

Maintain the air pressure in the rear tires at 12-14 psi (83-97 kPa). Uneven tire pressure can cause an uneven cut.

Note: The front tires are semi-pneumatic tires and do not require air pressure maintenance.

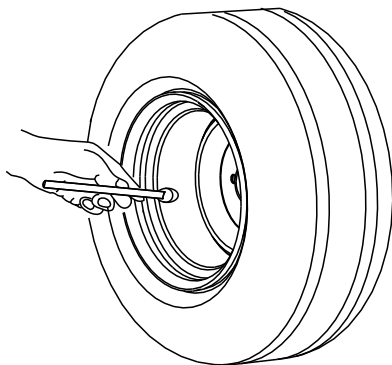

G001055

Figure 41

Replacing the Caster Wheel Fork Bushings

The caster wheel forks are mounted in bushings pressed into the top and bottom of the carrier frame mounting pivot tubes. To check the bushings, move the caster forks back and forth and side-to-side. If a caster fork is loose, the bushings are worn and must be replaced.

1. Raise the cutting unit so the caster wheels are off the floor, then support the front of the mower with jack stands.
2. Remove the locking pin and spacer(s) from the top of the caster wheel fork (Figure 42).

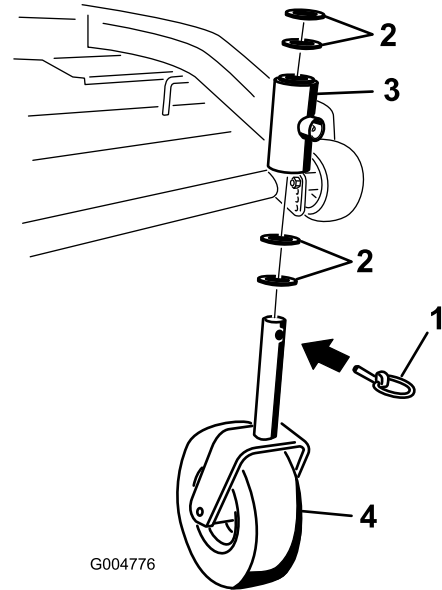

G004776

Figure 42

- | | |
|----------------|-----------------------------|
| 1. Locking Pin | 3. Carrier frame pivot tube |
| 2. Spacers | 4. Caster wheel |

3. Pull the caster wheel fork out of the mounting tube, leaving the spacer(s) on the bottom of the fork. Remember the location of the spacers on each fork to ensure correct installation, and to maintain a level deck.
4. Insert a pin punch into the mounting tube and carefully drive out the bushings (Figure 43). Clean the inside of the mounting tube.

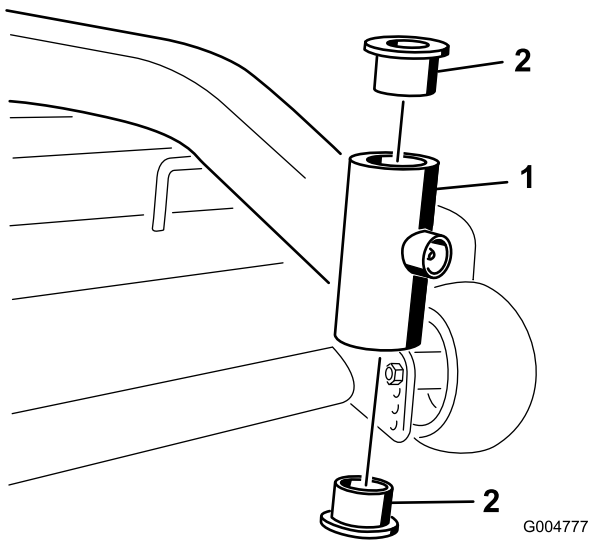

Figure 43

1. Mounting Tube 2. Bushing

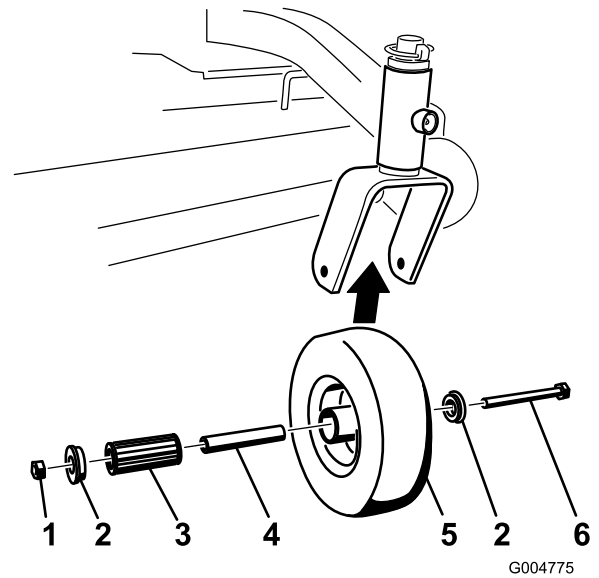

Figure 44

1. Locknut 4. Spanner Bushing
 2. Cap 5. Wheel
 3. Roller Bearing 6. Bushing

5. Grease the inside and outside of the new bushings. Use a hammer and flat plate to carefully drive the bushings into the pivot tubes.
6. Inspect the caster wheel fork for wear and replace if necessary (Figure 42).
7. Slide the caster wheel fork through the bushings in the mounting tube. Replace the spacer(s) onto the fork and secure with the retaining ring (Figure 42).

Important: The inside diameter of the bushings may collapse slightly when installed. If the caster wheel fork does not slide into the new bushings, ream both bushings to an inside diameter of 1.126 inch (29 mm).

8. Grease the fitting on the carrier frame pivot tubes using No. 2 general purpose lithium base or molybdenum base grease.

2. Remove one bushing, then pull the spanner bushing and roller bearing out of the wheel hub (Figure 44).
3. Remove the other bushing from the wheel hub and clean any grease and dirt from the wheel hub (Figure 44).
4. Inspect the roller bearing, bushings, spanner bushing and inside of the wheel hub for wear. Replace any defective or worn parts (Figure 44).
5. To assemble, place one bushing into the wheel hub. Grease the roller bearing and spanner bushing and slide them into the wheel hub. Place the second bushing into the wheel hub (Figure 44).
6. Install the caster wheel into the caster fork and secure with the wheel bolt and locknut. Tighten the locknut until the spanner bushing bottoms against the inside of the caster forks (Figure 44).
7. Grease the fitting on the caster wheel.

Servicing the Caster Wheel and Bearings

The caster wheels rotate on a roller bearing supported by a spanner bushing. If the bearing is kept well lubricated, wear will be minimal. Failure to keep the bearing well lubricated will cause rapid wear. A wobbly caster wheel usually indicates a worn bearing.

1. Remove the locknut and wheel bolt holding the caster wheel to the caster fork (Figure 44).

Adjusting the Electric Clutch

Service Interval: Every 100 hours

The clutch is adjustable to ensure proper engagement and proper braking.

1. Insert a 0.015–0.021 inch (0.381–0.533 mm) feeler gauge through one inspection slot in the side of the assembly. Make sure it is between the armature and the rotor friction surfaces.
2. Tighten the lock nuts until there is slight binding on the feeler gauge but it can be moved easily within the air gap (Figure 45).
3. Repeat this for the remaining slots.

4. Check each slot again and make slight adjustments until the feeler gauge between the rotor and armature with very slight contact between them.

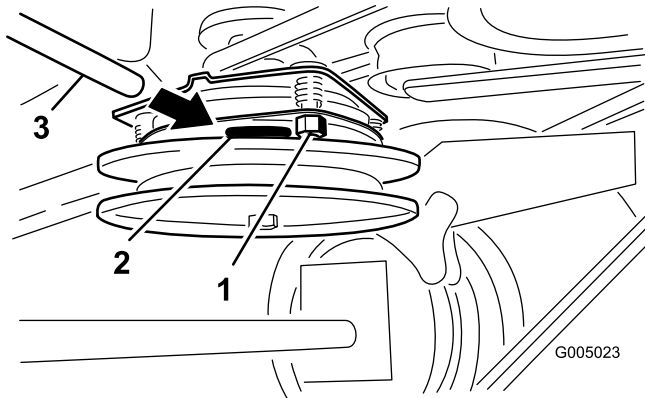

Figure 45

1. Adjusting nut
2. Slot
3. Feeler gauge

Cooling System Maintenance

Cleaning the Air Intake Screen

Service Interval: Before each use or daily

Remove any build-up of grass, dirt or other debris from the cylinder and cylinder head cooling fins, air intake screen on flywheel end, and carburetor-governor levers and linkage. This will help insure adequate cooling and correct engine speed and will reduce the possibility of overheating and mechanical damage to the engine.

Brake Maintenance

Servicing the Brakes

Service Interval: Before each use or daily—Check the brakes on both a level surface and slope.

Always set the parking brake when you stop the machine or leave it unattended. If the parking brake does not hold securely, an adjustment is required.

Checking the Brakes

1. Park the machine on a level surface, disengage the PTO.
2. Stop the engine, remove the key, and wait for all moving parts to stop before leaving the operating position.
3. Apply the parking brake. The wheels must lock when you try to push the machine forward.
4. If the wheels do not lock, adjust the brakes. Refer to Adjusting the Brakes.
5. Release the brake and press upper control bar very lightly, approximately 1/2 inch (13 mm). The wheels should rotate freely, if not; refer to Adjusting the Brakes.

Adjusting the Brakes

The brake lever is on the upper control bar. If the parking brake does not hold securely, an adjustment is required.

Note: For the initial adjustment, adjust the wing nut until it is 1-1/4 inches from the top of the rod (Figure 46).

1. Park the machine on a level surface, disengage the PTO, and set the parking brake.
2. Stop the engine, remove the key, and wait for all moving parts to stop before leaving the operating position.
3. Check the brake before you adjust it; refer to Checking the Brakes.
4. Release the parking brake; refer to Releasing the Parking Brake.
5. To adjust the brake remove the hair pin cotter and washer from the brake lever and trunnion (Figure 46).

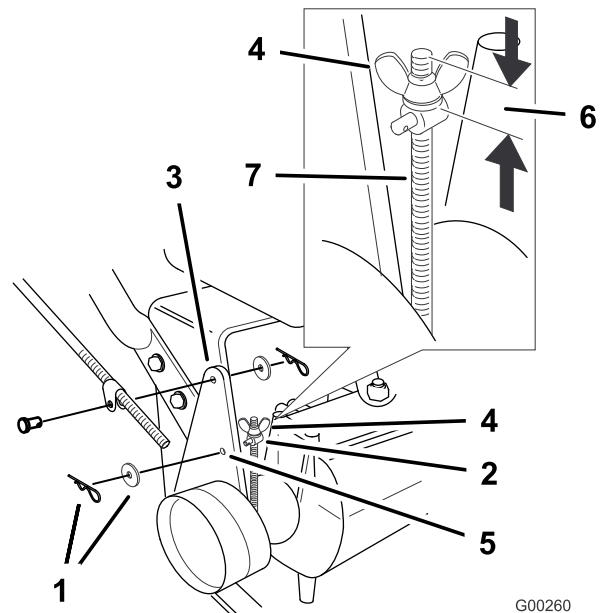

Figure 46

G00260

- | | |
|------------------------------|---|
| 1. Hairpin cotter and washer | 5. Hole F |
| 2. Trunnion | 6. Initial adjustment- 1-1/4 inch (32 mm) |
| 3. Brake lever | 7. Rod |
| 4. Wing nut | |

6. Rotate the wing nut clockwise to increase the braking pressure.
7. Rotate the wing nut counterclockwise to decrease the braking pressure.
8. Install the trunnion into hole F (Figure 46). Tighten the wing nut.
9. Secure trunnion to brake lever with washer and hair pin cotter (Figure 46).
10. Check the brake operation again; refer to Checking the Brakes.

Important: With the parking brake released, the rear wheels must rotate freely when you push the mower. If brake action and free wheel rotation cannot be achieved contact your service dealer immediately.

Belt Maintenance

Replacing the Traction Drive Belt

Service Interval: Every 50 hours/Monthly (whichever comes first)—Check the traction drive belt

Look for cracks, wear, and signs of overheating.

1. Remove the top bolt securing idler support and idler bracket to rear frame (Figure 47).

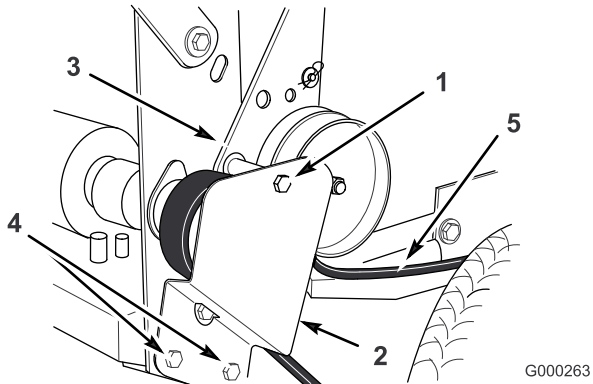

Figure 47

- | | |
|------------------|------------------------|
| 1. Top bolt | 4. Bottom bolt |
| 2. Idler bracket | 5. Traction drive belt |
| 3. Idler support | |

2. Loosen bottom two mounting screws enough to allow belt to pass between drive pulley and idler support (Figure 47).
3. Raise the wheel off the ground, to allow the belt to be removed, and remove the belt.
4. Install a new belt.
5. Install the top bolt securing the idler support and idler bracket to the rear frame (Figure 47).
6. Tighten the bottom two mounting screws enough to allow the belt to pass between the drive pulley and idler support (Figure 47).

Replacing the Transmission Belt

Service Interval: Every 50 hours

1. Disengage the PTO and set the parking brake.
2. Stop the engine, remove the key, and wait for all moving parts to stop before leaving the operating position.
3. Remove PTO drive belt. Refer to Replacing the PTO Drive Belt in the Belt Maintenance (page 33).
4. Raise the front of the machine and hold with jack stands.

5. Disconnect clutch wire connector from wire harness.
6. Disconnect clutch retainer from the engine deck (Figure 48).

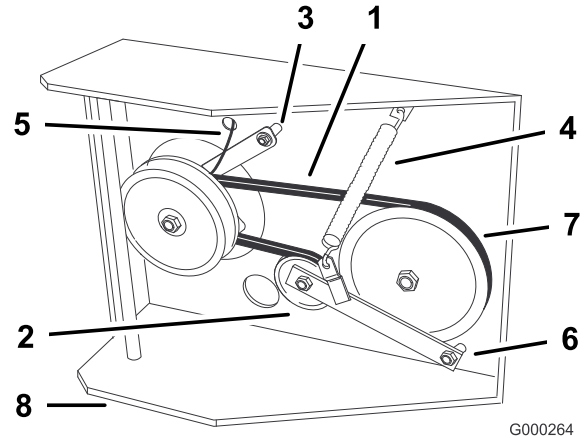

Figure 48

- | | |
|----------------------|--------------------------|
| 1. Transmission belt | 5. Clutch wire connector |
| 2. Idler pulley | 6. Pivot bolt |
| 3. Clutch retainer | 7. Drive pulley |
| 4. Tension spring | 8. Engine deck |

7. Unhook tension spring from side of frame (Figure 48).
8. Loosen pivot bolt enough to remove traction belt from the drive pulley and clutch.
9. Install new belt around clutch and drive pulley.
10. Torque pivot bolt to 35-40 ft-lb (47-54 N-m). Install tension spring between idler arm and frame bracket (Figure 48).
11. Install clutch retainer to the engine deck (Figure 48).
12. Connect clutch wire connector to wire harness.
13. Install PTO drive belt.

Replacing the Mower Belt

Service Interval: Every 50 hours

Squealing when the belt is rotating, blades slipping when cutting grass, frayed belt edges, burn marks and cracks are signs of a worn deck belt. Replace the deck belt if any of these conditions are evident.

1. Disengage the PTO and set the parking brake.
2. Stop the engine, remove the key, and wait for all moving parts to stop before leaving the operating position.
3. Unlatch and remove the carrier frame cover.
4. Unlatch and remove the belt covers.
5. Remove the PTO drive belt. Refer to Replacing the PTO Drive Belt.
6. Disconnect the idler arm spring to relieve tension on the idler arm and idler pulley, then remove the worn mower belt (Figure 49 or Figure 50).

7. Install the new mower belt around the two outside spindle pulleys, the idler pulley, and in the lower groove of the double spindle pulley (Figure 49 or Figure 50).
8. Connect the idler arm spring (Figure 49 or Figure 50).
9. Install the PTO drive belt. Refer to Replacing the PTO Drive Belt.
10. Adjust the belt guide an 1/8 inch (3 mm) from the belt (Figure 49 or Figure 50).
11. Install the belt covers onto the cutting unit and secure the latches.
12. Install the carrier frame cover onto the cutting unit and secure the latches.

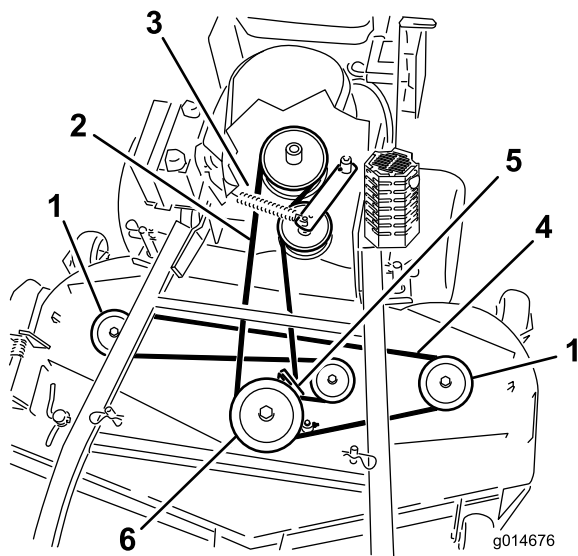

Figure 49

48 inch Mower Deck shown

- | | |
|---------------------|--------------------------|
| 1. Outside pulley | 4. Mower deck belt |
| 2. PTO drive belt | 5. Belt guide |
| 3. Idler arm spring | 6. Center spindle pulley |

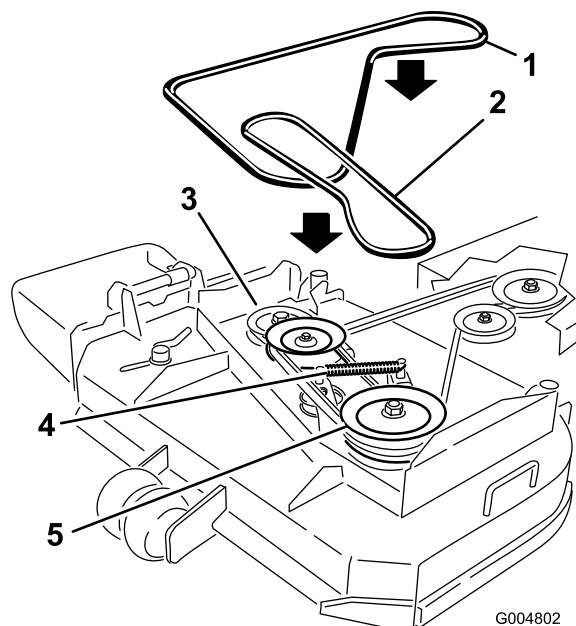

Figure 50

36 inch Mower Deck shown

- | | |
|----------------------|----------------------|
| 1. Mower deck belt | 4. Idler arm spring |
| 2. PTO drive belt | 5. Drive belt pulley |
| 3. Drive belt pulley | |

Replacing the PTO Drive Belt

Service Interval: Every 50 hours

Squealing when the belt is rotating, blades slipping when cutting grass, frayed belt edges, burn marks and cracks are signs of a worn drive belt. Replace the drive belt if any of these conditions are evident.

1. Disengage the PTO and set the parking brake.
2. Stop the engine, remove the key, and wait for all moving parts to stop before leaving the operating position.
3. Unlatch and remove the carrier frame cover.
4. Unlatch and remove the belt covers.
5. Remove the heat shield from the engine deck and carrier frame.
6. Roll the belt off of the center pulley on the mower deck (Figure 51). Refer to Figure 52 to roll the belt off left pulley for a 36 inch mower deck. Use caution when removing the belt as tension will increase because of the spring loaded idler pulley.
7. Remove the belt from the engine pulley and the spring loaded idler pulley (Figure 51). Refer to Figure 52 to remove the belt from the 36 inch mower deck pulleys.
8. Install the new belt onto the engine pulley and spring loaded idler pulley (Figure 51).
9. Roll the belt onto the center pulley on the mower deck (Figure 51). Use caution when install the belt as tension will increase because of the spring loaded idler pulley.

Refer to Figure 52 to roll the new belt onto the left pulley for a 36 inch mower deck.

10. Install the heat shield to the engine deck and carrier frame.
11. Adjust the belt guide an 1/8 inch (3 mm) from the belt for 48 inch mower decks (Figure 51).
12. Install the belt covers onto the cutting unit and secure the latches.
13. Install the carrier frame cover onto the carrier frame and secure the latches.

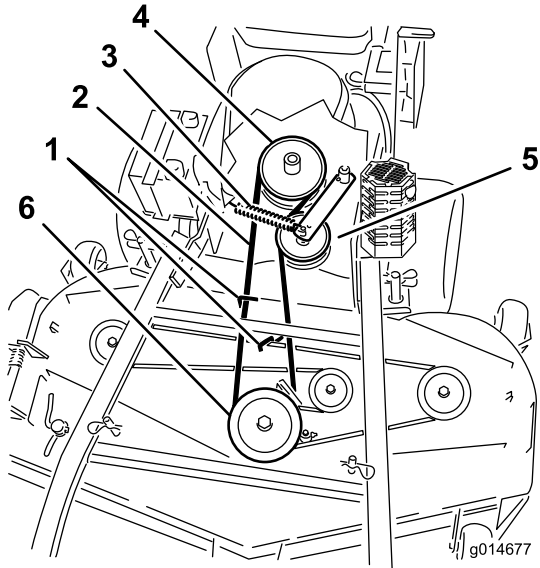

Figure 51
48 inch Mower Deck shown

- | | |
|-------------------------|--------------------------------|
| 1. PTO drive belt guide | 4. PTO engagement pulley |
| 2. PTO drive Belt | 5. PTO drive belt idler pulley |
| 3. Idler spring | 6. Center spindle pulley |

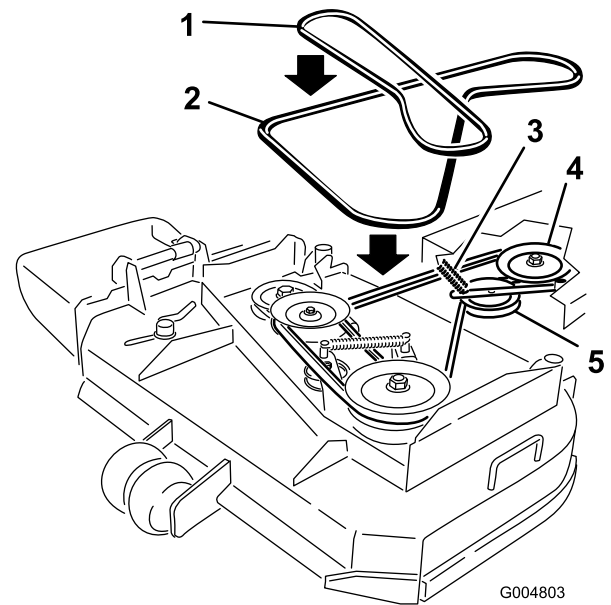

Figure 52
36 inch Mower Deck shown

- | | |
|-------------------------|------------------|
| 1. Mower deck belt | 4. Clutch pulley |
| 2. PTO Drive Belt | 5. Idler pulley |
| 3. Idler arm and spring | |

Adjusting the PTO Drive Belt Idler Spring Anchor

The position of the PTO idler can be adjusted to increase or decrease belt tension.

Use Figure 53 for the idler position options.

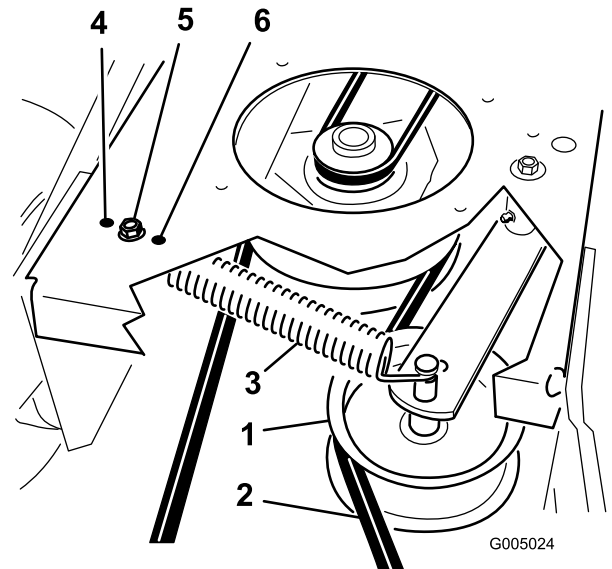

Figure 53

- | | |
|--------------------------------|--|
| 1. PTO drive belt idler pulley | 4. Most tension for worn belts |
| 2. PTO drive Belt | 5. Medium tension for normal belt conditions |
| 3. Idler spring | 6. Least tension for new belts |

Mower Deck Maintenance

Servicing the Cutting Blades

To ensure a superior quality of cut, keep the blades sharp. For convenient sharpening and replacement, you may want to keep extra blades on hand.

⚠ WARNING

A worn or damaged blade can break, and a piece of the blade could be thrown into the operator's or bystander's area, resulting in serious personal injury or death.

- Inspect the blades periodically for wear or damage.
- Replace a worn or damaged blade.

Before Inspecting or Servicing the Blades

Park the machine on a level surface, disengage the blades and set the parking brake. Turn the ignition key to off. Remove the key and disconnect the spark plug wires from the spark plugs.

Inspecting the Blades

Service Interval: Before each use or daily

1. Inspect the cutting edges (Figure 54). If the edges are not sharp or have nicks, remove and sharpen the blades. Refer to Sharpening the Blades.

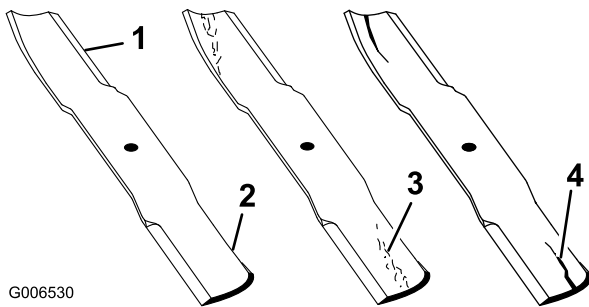

Figure 54

1. Cutting Edge
2. Sail
3. Wear/slot forming in curved area
4. Crack in the curved area

2. Inspect the blades, especially the curved area (Figure 54). If you notice any cracks, wear, or a slot forming in this area (item 3. in Figure 54), immediately install a new blade.

Checking for Bent Blades

1. Disengage the PTO, move the motion control levers to the neutral locked position and set the parking brake.
2. Stop the engine, remove the key, and wait for all moving parts to stop before leaving the operating position.
3. Rotate the blades until the ends face forward and backward. Measure from a level surface to the cutting edge, position A, of the blades (Figure 55). Note this dimension. For 36 inch mower decks use Figure 56.

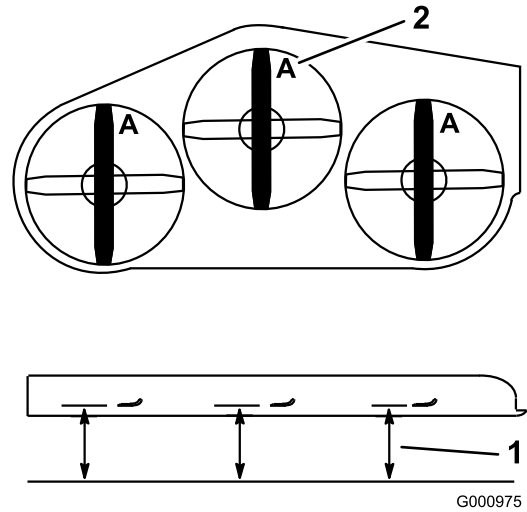

Figure 55

48 inch Mower Deck shown

1. Measure here from blade
2. Position A to hard surface

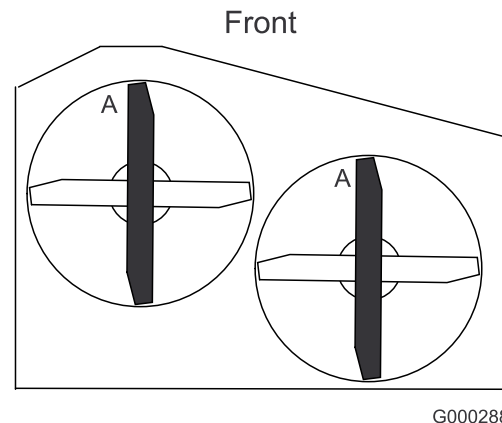

Figure 56

36 inch Mower Deck shown

4. Rotate the opposite ends of the blades forward.
5. Measure from a level surface to the cutting edge of the blades at the same position as in step 3 above. The difference between the dimensions obtained in steps 3 and 4 must not exceed 1/8 inch (3 mm). If this dimension exceeds 1/8 inch (3 mm), the blade is bent and must be replaced; refer to Removing the Blades and Installing the Blades.

⚠ WARNING

A blade that is bent or damaged could break apart and could seriously injure or kill you or bystanders.

- Always replace bent or damaged blade with a new blade.
- Never file or create sharp notches in the edges or surfaces of blade.

Removing the Blades

Blades must be replaced if a solid object is hit, if the blade is out of balance or is bent. To ensure optimum performance and continued safety conformance of the machine, use genuine Toro replacement blades. Replacement blades made by other manufacturers may result in non-conformance with safety standards.

1. Hold the blade end using a rag or thickly-padded glove.
2. For 48 inch mower decks, remove the blade bolt, curved washer, and blade from the spindle shaft (Figure 57).

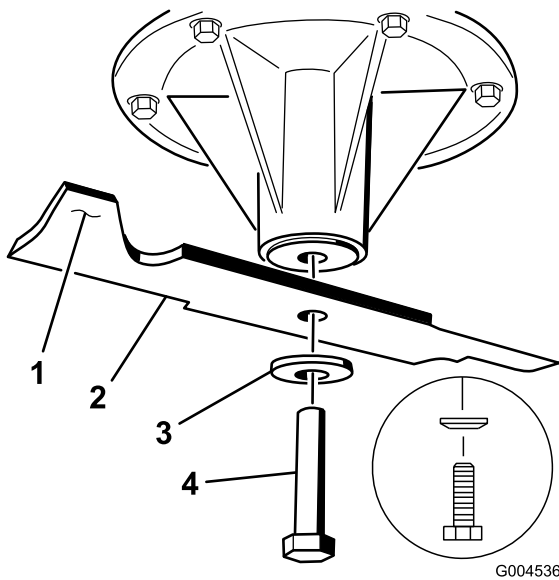

Figure 57

48 inch Mower Decks

- | | |
|-----------------------|------------------|
| 1. Sail Area of Blade | 3. Curved washer |
| 2. Blade | 4. Blade Bolt |

3. For 36 inch mower decks, remove the blade bolt, curved washer, blade stiffener, and blade from the spindle shaft (Figure 58).

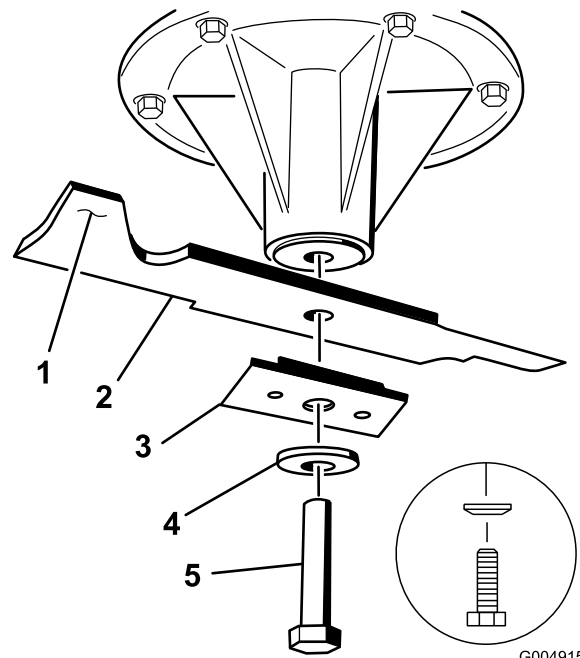

Figure 58

36 inch Mower Decks

- | | |
|-----------------------|------------------|
| 1. Sail Area of Blade | 4. Curved washer |
| 2. Blade | 5. Blade Bolt |
| 3. Blade stiffener | |

Sharpening the Blades

1. Use a file to sharpen the cutting edge at both ends of the blade (Figure 59). Maintain the original angle. The blade retains its balance if the same amount of material is removed from both cutting edges.

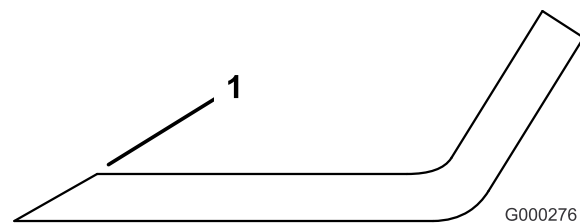

Figure 59

1. Sharpen at original angle
2. Check the balance of the blade by putting it on a blade balancer (Figure 60).
3. If the blade stays in a horizontal position, the blade is balanced and can be used. If the blade is not balanced, file some metal off the end of the sail area only (Figure 57)
4. Repeat this procedure until the blade is balanced.

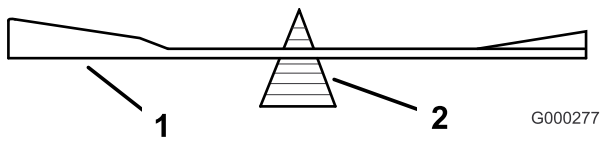

Figure 60

1. Blade
2. Balancer

Installing the Blades

1. Install the blade onto the spindle shaft (Figure 57).

Important: The sail part of the blade must be pointing upward, toward the inside of the mower to ensure proper cutting (Figure 57).
2. For 48 inch mower decks, install the blade, curved washer, and blade bolt (Figure 57).
3. For 36 inch mower decks, install the blade, stiffener, curved washer, and blade bolt (Figure 58).
4. Torque the blade bolt to 85-110 ft-lb (115-140 N-m).

Correcting the Mower Quality of Cut

If one deck blade cuts lower than the other, correct as follows.

Note: Tire air pressure is critical in these procedures. Make sure all tires have correct pressure.

1. Disengage the PTO and set the parking brake.
2. Stop the engine, remove the key, and wait for all moving parts to stop before leaving the operating position. Disconnect the spark plug wire(s) from the spark plug(s).
3. Adjust the tire pressure in the rear tires to specifications.
4. Check that the blades and spindle shafts are not bent. Refer to Checking for Bent Blades.
5. Set the height-of-cut to the 4 inch (101.6 mm) position. Refer to Adjusting the Height-Of-Cut.
6. Perform the steps in the following sections Frame Set Up, Checking Front-to-Rear Pitch, and Checking Side-to-Side Leveling.

Frame Set Up

Checking the Carrier Frame and Engine Deck Alignment

Note: Misalignment can cause excess wear on the PTO drive belt.

1. Disengage the PTO and set the parking brake.
2. Stop the engine, remove the key, and wait for all moving parts to stop before leaving the operating position.
3. Place a long straight edge on top of the engine deck as shown in Figure 61.
4. At the carrier frame cross channel, measure the height at location **A** (Figure 61). This measurement must be 1-5/16 inch (33 mm), plus or minus a 1/4 inch (6 mm).
5. If the height at location **A** is not correct, adjustment is needed.
6. Loosen the carrier frame mounting bolts on both sides of the machine (Figure 61).
7. Align the carrier frame and engine deck to match 1-5/16 inch (33 mm), plus or minus a 1/4 inch (6 mm) at location **A** (Figure 61).
8. Tighten the carrier frame mounting bolts on both sides of the machine.

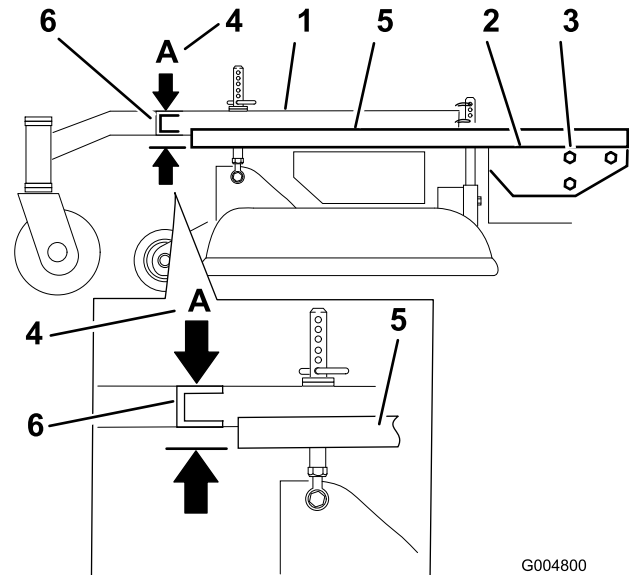

Figure 61

- | | |
|---------------------------------|--|
| 1. Carrier Frame | 4. Location A, 1-5/16 inch (33 mm) \pm 1/4 inch (6 mm) |
| 2. Top of engine deck | 5. Straight edge |
| 3. Carrier frame mounting bolts | 6. Carrier frame cross channel |

Checking the Engine Deck Height

1. Disengage the PTO and set the parking brake.
2. Stop the engine, remove the key, and wait for all moving parts to stop before leaving the operating position.
3. Adjust the tire pressure in the rear tires to specifications; refer to Drive System Maintenance (page 28) .
4. Measure engine deck height at location **A** (Figure 62).

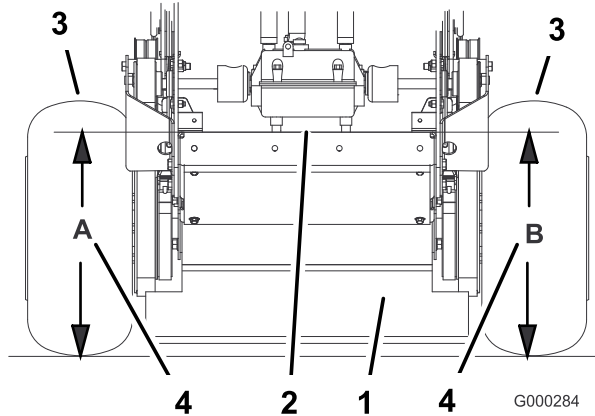

Figure 62

- | | |
|-------------------------|---|
| 1. Back view of machine | 3. Tires |
| 2. Top of engine deck | 4. Same height at locations A and B |

5. Measure engine deck height at location **B** (Figure 62).
6. If the height at location **A** and **B** are not the same, change tire pressure slightly to make them the same.

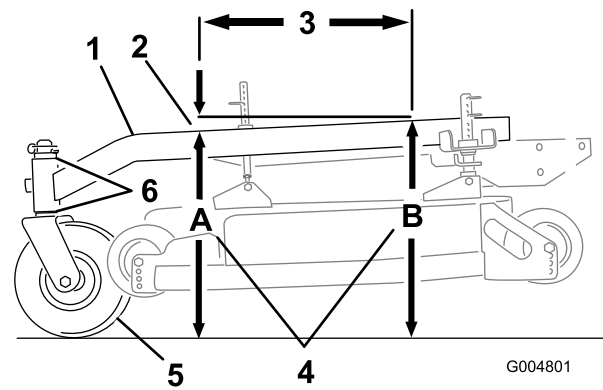

Figure 63

- | | |
|---|--|
| 1. Carrier Frame | 4. Height at locations A and B |
| 2. 1/4-3/8 inch (6-10 mm) pitch over 24 inch (61 cm) length | 5. Caster Wheel |
| 3. 24 inches (61 cm) | 6. Caster spacers |

2. Measure carrier frame height at location **A** (Figure 63).
3. Measure carrier frame height at location **B** (Figure 63).
4. The height at location **A** must be a 1/4-3/8 inch (6 mm -10 mm) lower than location **B** (Figure 63).
5. If the carrier frame is not correct, move caster spacers to make it a 1/4-3/8 inch (6 -10 mm) pitch (Figure 63). Move spacers from top or bottom to make the correct pitch.
6. The tire pressure may also be adjusted slightly to make a 1/4 inch (6 mm) pitch.

Checking the Carrier Frame Front-to-Rear Pitch

The carrier frame must have a pitch between 1/8 inch (3 mm) to 3/8 inch (9 mm) over the length of 24 inches (61 cm) on the carrier frame (Figure 63).

1. Measure out 24 inches (61 cm) on the carrier frame (Figure 63).

Checking the Carrier Frame Side-to-Side Height

The carrier frame needs to be parallel side-to-side from the ground.

1. Disengage the PTO and set the parking brake.
2. Stop the engine, remove the key, and wait for all moving parts to stop before leaving the operating position.
3. Adjust the tire pressure in the rear tires to specifications; refer to Drive System Maintenance (page 28) .
4. Measure carrier frame height at location **A** (Figure 64).
5. Measure carrier frame height at location **B** (Figure 64).
6. If the carrier frame height is not the same move spacers from top or bottom of caster wheel, to make it level. The tire pressure may also be adjusted slightly to make it level.

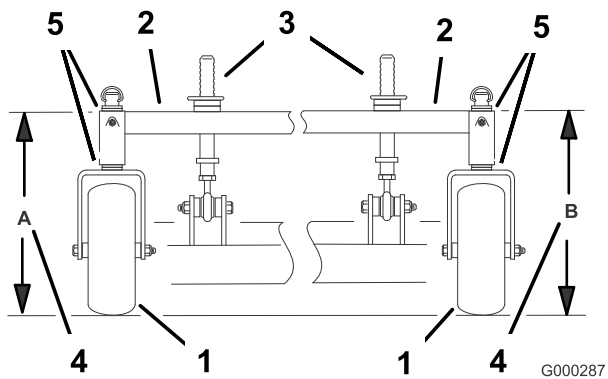

Figure 64

- | | |
|-----------------------------|-------------------------------------|
| 1. Caster Wheel | 4. Same height at locations A and B |
| 2. Carrier Frame | 5. Caster spacers |
| 3. Front height-of-cut pins | |

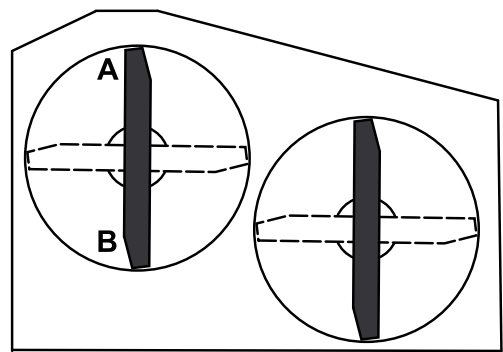

Figure 66

36 inch Mower Deck shown

Checking the Mower Deck Front-to-Rear Pitch

1. Adjust the tire pressure in the rear tires to specifications; refer to Drive System Maintenance (page 28) .
2. Position one blade front-to-rear. Measure at **A** and **B** locations from a level surface to the cutting edge of the blade tips (Figure 65 or Figure 66). For 36 inch mower decks use Figure 66.
3. The mower blade should be a 1/4 inch (6 mm) lower in front at **A** than in the rear at **B**. Rotate blades and repeat for other blades. If it is not correct, proceed to Changing the Deck Front-to-Rear Pitch.

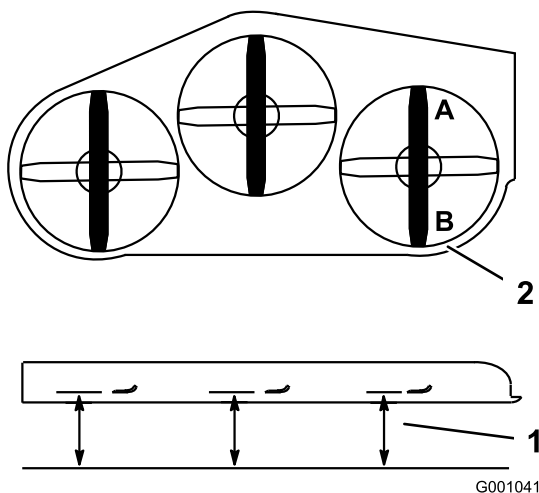

Figure 65

48 inch Mower Deck shown

- | | |
|------------------------------------|---------------------------------|
| 1. Measure blade at points A and B | 2. Measure from a level surface |
|------------------------------------|---------------------------------|

Changing the Mower Deck Front-to-Rear Pitch

Changing the front-to-rear pitch is done by adjusting the front height-of-cut posts.

1. To change the front-to-rear pitch, the front height-of-cut posts can be adjusted (Figure 67).

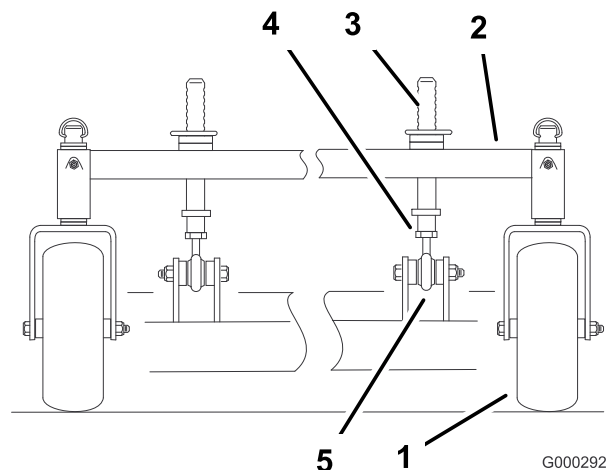

Figure 67

- | | |
|-----------------------------|---------------|
| 1. Caster Wheel | 4. Jam nut |
| 2. Carrier Frame | 5. Ball joint |
| 3. Front height-of-cut pins | |
2. To raise the front of the deck, loosen jam nut and rotate the front pin clockwise (Figure 67).
 3. To lower the front of the deck, loosen jam nut and rotate the front pin counter clockwise (Figure 67).
 4. Position the blades front-to-rear. Measure at C and D locations (Figure 65) from a level surface to the cutting edge of the blades.
 5. Check the side-to-side leveling of the cutting unit.
 6. Tighten the jam nuts (Figure 67).

Checking the Mower Deck Side-to-Side Height

1. Adjust the rear tire pressure to specifications; refer to Drive System Maintenance (page 28) .
2. Position the blades side-to-side. Measure at **C** and **D** locations from a level surface to the cutting edge of blade tips (Figure 68). For 36 inch mower decks use Figure 69.

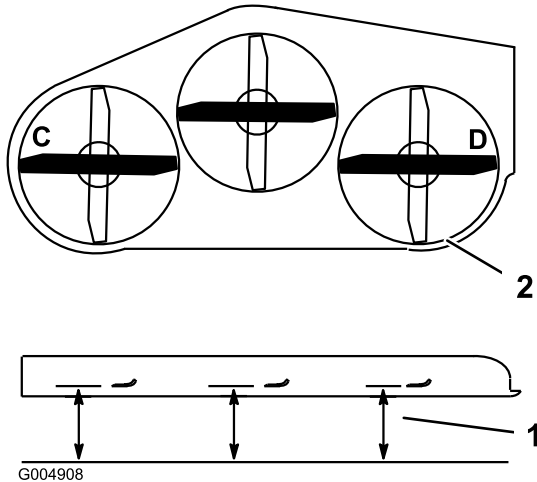

Figure 68

48 inch Mower Deck shown

1. Measure from a level surface
2. Measure blade at points **C** and **D**

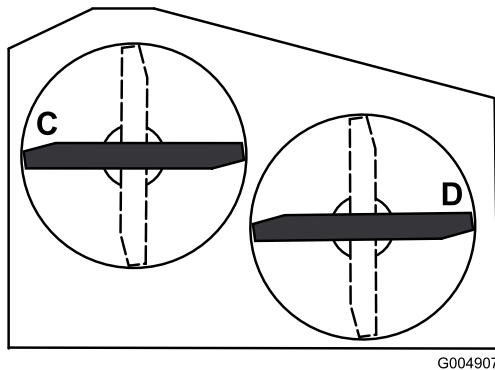

Figure 69

36 inch Mower Deck shown

3. The difference between measurements **C** and **D** should be no more than 1/4 inch (6 mm).

Changing the Mower Deck Side-to-Side Height

Changing the side-to-side height is done by adjusting the rear tire pressure and caster spacers.

1. Change the rear tire pressure. Do this to the corresponding side that needs adjustment.
2. Adjust the caster spacer.
3. Recheck the front-to-rear pitch and side to side leveling of the cutting unit.

Matching Height of Cut

1. Check the rear tire pressure.
2. Set the height-of-cut to the 4 inch (101.6 mm) position following the height-of-cut decal.
3. With the machine on level surface, position one blade front-to-rear. Measure at **A** and from level surface to the cutting edge of the blade tips (Figure 70). For 36 inch mower decks use Figure 71.

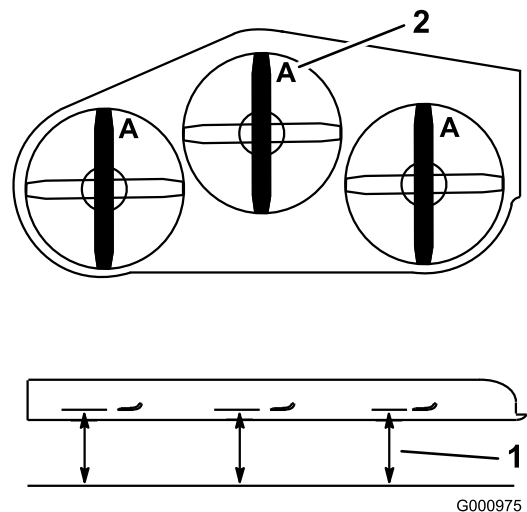

Figure 70

48 inch Mower Deck shown

1. Measure from a level surface
2. Measure blade at point **A** surface

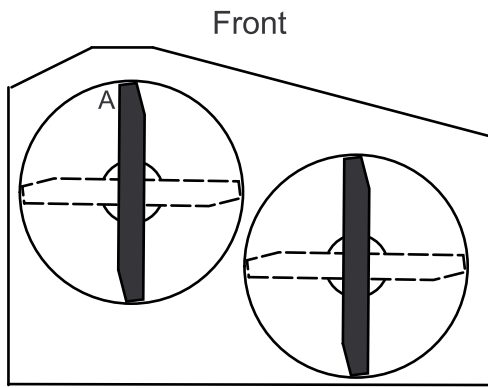
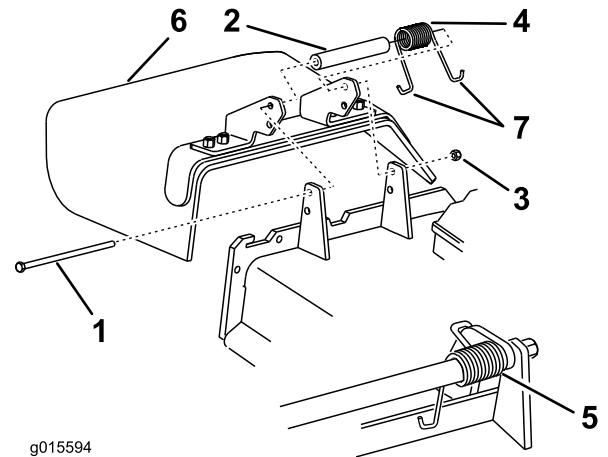

Figure 71

36 inch Mower Deck shown

G000296



g015594

Figure 72

4. The measurement should be 4 inch (101.6 mm).
5. If it does not measure correctly:
 - A. Adjust the rear tire pressure.
 - B. Adjust the caster fork spacers.
 - C. Adjust the front mower deck support pins.
6. Check the carrier frame front-to-rear pitch.

1. Bolt
2. Spacer
3. Locknut
4. Spring
5. Spring installed
6. Grass Deflector
7. J hook end of spring

Replacing the Grass Deflector

⚠ WARNING

An uncovered discharge opening could allow the lawn mower to throw objects in the operator's or bystander's direction and result in serious injury. Also, contact with the blade could occur.

Never operate the lawn mower unless you install a cover plate, a mulch plate, grass deflector or bagger.

1. Remove the locknut, bolt, spring and spacer holding the deflector to the pivot brackets (Figure 72). Remove the damaged or worn grass deflector.

2. Place the spacer and spring onto the grass deflector. Place one **J** end of the spring behind the deck edge.
3. Install the bolt and nut. Place one **J** hook end of the spring around the grass deflector (Figure 72).

Note: Make sure one **J** end of the spring is installed behind the deck edge before installing the bolt as shown in Figure 72.

Important: The grass deflector must be able to rotate. Lift the deflector up to the full open position and ensure that it rotates into the full down position.

Storage

Cleaning and Storage

1. Disengage the power take off (PTO), set the parking brake, and turn the ignition key to off. Remove the key.
2. Remove grass clippings, dirt, and grime from the external parts of the entire machine, especially the engine. Clean dirt and chaff from the outside of the engine's cylinder head fins and blower housing.
Important: You can wash the machine with mild detergent and water. Do not pressure wash the machine. Avoid excessive use of water, especially near the shift lever plate, and engine.
3. Check the brake; refer to Servicing the Brake in Brake Maintenance (page 32).
4. Service the air cleaner; refer to Servicing the Air Cleaner in Engine Maintenance (page 23).
5. Grease the machine; refer to Greasing and Lubrication in Lubrication (page 22).
6. Change the engine oil; refer to Servicing the Engine in Engine Maintenance (page 23).
7. Check the tire pressure; refer to Checking the Tire Pressure in Drive System Maintenance (page 28).
8. For long-term storage:
 - A. Add stabilizer/conditioner additive to fuel in the tank.
 - B. Run engine to distribute conditioned fuel through the fuel system (5 minutes).
 - C. Stop engine, allow to cool and drain the fuel tank; refer to Servicing the Fuel Tank in Fuel System Maintenance (page 27), or operate engine until it stops.
 - D. Restart engine and run until it stops. Repeat, on Choke until engine will not restart.
 - E. Dispose of fuel properly. Recycle as per local codes.
Note: Do not store stabilizer/conditioned gasoline over 90 days.
9. Remove the spark plug(s) and check its condition; refer to Servicing the Spark Plug in Engine Maintenance (page 23). With the spark plug(s) removed from the engine, pour two tablespoons of engine oil into the spark plug hole. Now use the starter to crank the engine and distribute the oil inside the cylinder. Install the spark plug(s). Do not install the wire on the spark plug(s).
10. Check and tighten all bolts, nuts, and screws. Repair or replace any part that is damaged or defective.
11. Paint all scratched or bare metal surfaces. Paint is available from your Authorized Service Dealer.
12. Store the machine in a clean, dry garage or storage area. Remove the key from the ignition switch and keep it in a memorable place. Cover the machine to protect it and keep it clean.

Troubleshooting

Problem	Possible Cause	Corrective Action
Engine will not start, starts hard, or fails to keep running.	<ol style="list-style-type: none"> 1. Fuel tank is empty. 2. Choke is not on. 3. Air cleaner is dirty. 4. Spark plug wire is loose or disconnected. 5. Spark plug is pitted, fouled, or the gap is incorrect. 6. Dirt in the fuel filter. 7. Dirt, water, or stale fuel is in the fuel system. 	<ol style="list-style-type: none"> 1. Fill fuel tank with gasoline. 2. Move the choke lever to choke position. 3. Clean or replace the air cleaner element. 4. Install wire on spark plug. 5. Install a new, correctly gapped spark plug. 6. Replace the fuel filter. 7. Contact an Authorized Service Dealer.
Engine loses power.	<ol style="list-style-type: none"> 1. Engine load is excessive. 2. Air cleaner is dirty. 3. Oil level in the crankcase is low. 4. Cooling fins and air passages under the engine blower housing are plugged. 5. Spark plug is pitted, fouled, or the gap is incorrect. 6. Vent hole in the fuel cap is plugged. 7. Dirt in the fuel filter. 8. Dirt, water, or stale fuel is in the fuel system. 	<ol style="list-style-type: none"> 1. Reduce the ground speed. 2. Service the air cleaner. 3. Add oil to the crankcase. 4. Remove the obstruction from the cooling fins and air passages. 5. Install a new, correctly gapped spark plug. 6. Clean or replace the fuel cap. 7. Replace the fuel filter. 8. Contact an Authorized Service Dealer.
Engine overheats.	<ol style="list-style-type: none"> 1. Engine load is excessive. 2. Oil level in the crankcase is low. 3. Cooling fins and air passages under the engine blower housing are plugged. 	<ol style="list-style-type: none"> 1. Reduce the ground speed. 2. Add oil to the crankcase. 3. Remove the obstruction from the cooling fins and air passages.
Machine does not drive.	<ol style="list-style-type: none"> 1. Shift lever is in neutral. 2. Traction belt is worn, loose or broken. 3. Traction belt is off a pulley. 4. Broken or missing idler spring. 	<ol style="list-style-type: none"> 1. Move shift lever to a drive gear position. 2. Change the belt. 3. Change the belt. 4. Replace the spring.
Abnormal vibration.	<ol style="list-style-type: none"> 1. Cutting blade(s) is/are bent or unbalanced. 2. Blade mounting bolt is loose. 3. Engine mounting bolts are loose. 4. Loose engine pulley, idler pulley, or blade pulley. 5. Engine pulley is damaged. 6. Blade spindle is bent. 	<ol style="list-style-type: none"> 1. Install new cutting blade(s). 2. Tighten the blade mounting bolt. 3. Tighten the engine mounting bolts. 4. Tighten the appropriate pulley. 5. Contact an Authorized Service Dealer. 6. Contact an Authorized Service Dealer.
Uneven cutting height.	<ol style="list-style-type: none"> 1. Blade(s) not sharp. 2. Cutting blade(s) is/are bent. 3. Mower is not level. 4. Mower pitch is wrong. 5. Underside of mower is dirty. 6. Tire pressure is not correct. 7. Blade spindle bent. 	<ol style="list-style-type: none"> 1. Sharpen the blade(s). 2. Install new cutting blade(s). 3. Level the mower side-to-side position. 4. Adjust the front-to-rear pitch. 5. Clean the underside of the mower. 6. Adjust the tire pressure. 7. Contact an Authorized Service Dealer.

Problem	Possible Cause	Corrective Action
Blades do not rotate.	<ol style="list-style-type: none"> 1. Drive belt is worn, loose or broken. 2. Drive belt is off pulley. 3. Deck belt is worn, loose or broken. 4. Deck belt is off pulley. 5. Broken or missing idler spring. 6. Electric clutch out of adjustment. 7. Clutch connector or wire damaged. 8. Damaged electric clutch. 9. Safety interlock system prevents blade rotation. 10. PTO switch is faulty. 	<ol style="list-style-type: none"> 1. Check the belt tension. 2. Install drive belt and check adjusting shafts and belt guides for correct position. 3. Install new deck belt. 4. Install deck pulley and check the idler pulley, idler arm and spring for correct position and function. 5. Replace the spring. 6. Adjust the clutch air gap. 7. Contact an Authorized Service Dealer. 8. Contact an Authorized Service Dealer. 9. Contact an Authorized Service Dealer. 10. Contact an Authorized Service Dealer.

Schematics

KAWASAKI GEAR M.S.

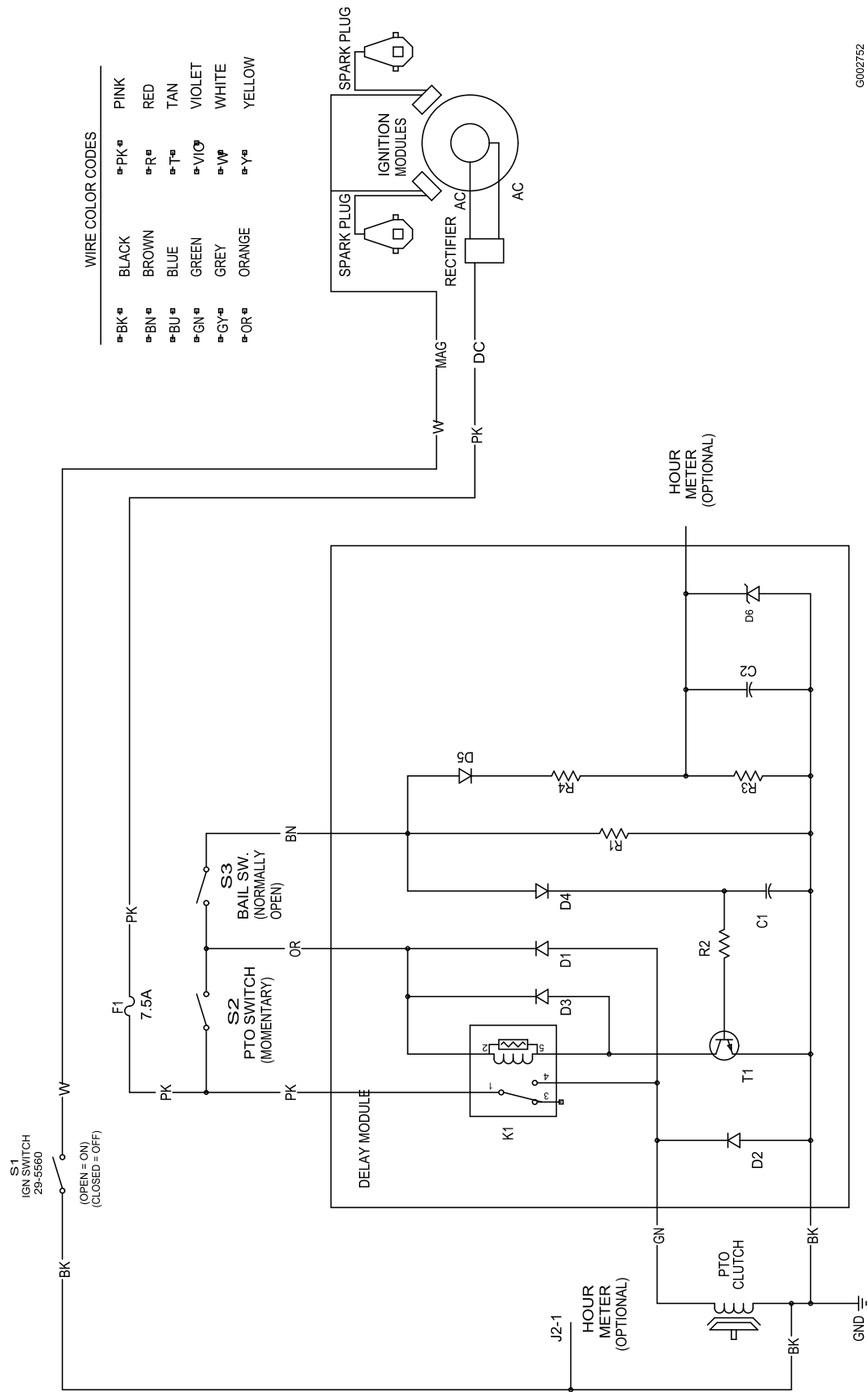

WIRE COLOR CODES

■BK■	■PK■	■PK■	■PK■	■PK■	■PK■	■PK■
■BN■	■BN■	■R■	■R■	■R■	■R■	■R■
■BU■	■BU■	■T■	■T■	■T■	■T■	■T■
■GN■	■GN■	■V■	■V■	■V■	■V■	■V■
■GY■	■GY■	■W■	■W■	■W■	■W■	■W■
■OR■	■OR■	■Y■	■Y■	■Y■	■Y■	■Y■

Electrical Schematic (Rev. A)

G002752

Notes:



The Toro Total Coverage Warranty

A Limited Warranty (see warranty periods below)

Landscape
Contractor
Equipment (LCE)

Conditions and Products Covered

The Toro Company and its affiliate, Toro Warranty Company, pursuant to an agreement between them, jointly promise to the original purchaser to repair the Toro Products listed below if defective in materials or workmanship.

The following time periods apply from the date of purchase by the original owner:

Products	Warranty Period
21 in. Mowers • Engines ⁴	1 year Commercial Use Honda – 1 years Kawasaki – 3 years
21 in. Mowers • Engines ⁴	2 years Residential Use ¹ Honda – 2 years Kawasaki – 3 years
30 in. Mowers • Engines ⁴	2 years Commercial and Residential Use ¹ Kawasaki – 3 years
Mid-Size Walk-Behind Mowers • Engines ⁴	2 years Kawasaki – 3 years
Grand Stand® Mowers • Engines ⁴ • Frame	5 years or 1,200 hours ² Kawasaki – 3 years Kohler EFI – 3 years Lifetime (original owner only) ³
Z Master® 2000 Series Mowers • Engines ⁴ • Frame	4 years or 500 hours ² Kawasaki – 3 years Lifetime (original owner only) ³
Z Master® 3000 Series Mowers • Engines ⁴ • Frame	5 years or 1,200 hours ² Kawasaki – 3 years Lifetime (original owner only) ³
Z Master® 5000 Series Mowers • Engines ⁴ • Frame	5 years or 1,200 hours ² Kohler Command – 2 years Kohler EFI – 3 years Lifetime (original owner only) ³
Z Master® 6000 Series Mowers • Engines ⁴ • Frame	5 years or 1,200 hours ² Kawasaki – 3 years Kohler Command – 2 years Kohler EFI – 3 years Lifetime (original owner only) ³
Z Master®7000 Series Mowers • Engines ⁴ • Frame	4 years or 1,200 hours ² Kubota – 2 years Briggs & Stratton – 2 years Lifetime (original owner only) ³
All Mowers • Battery	90 days Parts and Labor 1 year Parts only
• Belts and Tires	90 days
• Attachments	1 year

¹Residential use means use of the product on the same lot as your home. Use at more than one location is considered commercial use and the commercial warranty would apply.

²Whichever occurs first.

³Lifetime Frame Warranty - If the main frame, consisting of the parts welded together to form the tractor structure that other components such as the engine are secured to, cracks or breaks in normal use, it will be repaired or replaced, at Toro's option, under warranty at no cost for parts and labor. Frame failure due to misuse or abuse and failure or repair required due to rust or corrosion are not covered.

⁴Some engines used on Toro Products are warranted by the engine manufacturer.

This warranty includes the cost of parts and labor, but you must pay transportation costs.

Instructions for Obtaining Warranty Service

If you think that your Toro Product contains a defect in materials or workmanship, follow this procedure:

1. Contact any Authorized Toro Service Dealer to arrange service at their dealership. To locate a dealer convenient to you, refer to the Yellow Pages of your telephone directory (look under "Lawn Mowers") or access our web site at www.Toro.com. You may also call the numbers listed in item #3 to use the 24-hour Toro Dealer locator system.
2. Bring the product and your proof of purchase (sales receipt) to the Service Dealer. The dealer will diagnose the problem and determine if it is covered under warranty.
3. If for any reason you are dissatisfied with the Service Dealer's analysis or with the assistance provided, contact us at:

RLC Customer Care Department
Toro Warranty Company
8111 Lyndale Avenue South
Bloomington, MN 55420-1196
888-865-5676 (U.S. Customers)
888-865-5691 (Canada customers)

Owner Responsibilities

You must maintain your Toro Product by following the maintenance procedures described in the *Operator's Manual*. Such routine maintenance, whether performed by a dealer or by you, is at your expense.

Items and Conditions Not Covered

There is no other express warranty except for special emission system and engine warranty coverage on some products. This express warranty does not cover the following:

- Cost of regular maintenance service or wear parts, such as filters, fuel, lubricants, tune-up parts, blade sharpening, brake and clutch adjustments.
- Any product or part which has been altered or misused and requires replacement or repair due to normal wear, accidents, or lack of proper maintenance.
- Repairs necessary due to improper fuel, contaminants in the fuel system, or failure to properly prepare the fuel system prior to any period of non-use over three months.
- Pickup and delivery charges.

General Conditions

All repairs covered by these warranties must be performed by an Authorized Toro Service Dealer using Toro approved replacement parts.

Neither The Toro Company nor Toro Warranty Company is liable for indirect, incidental or consequential damages in connection with the use of the Toro Products covered by this warranty, including any cost or expense of providing substitute equipment or service during reasonable periods of malfunction or non-use pending completion of repairs under this warranty.

All implied warranties of merchantability (that the product is fit for ordinary use) and fitness for use (that the product is fit for a particular purpose) are limited to the duration of the express warranty.

Some states do not allow exclusions of incidental or consequential damages, or limitations on how long an implied warranty lasts, so the above exclusions and limitations may not apply to you.

This warranty gives you specific legal rights, and you may also have other rights which vary from state to state.

Countries Other than the United States or Canada

Customers who have purchased Toro products outside the United States or Canada should contact their Toro Distributor (Dealer) to obtain guarantee policies for your country, province, or state. If for any reason you are dissatisfied with your Distributor's service or have difficulty obtaining guarantee information, contact the Toro importer. If all other remedies fail, you may contact us at Toro Warranty Company.

Australian Consumer Law: Australian customers will find details relating to the Australian Consumer Law either inside the box or at your local Toro Dealer. 374-0252 Rev E