



Count on it.

Operator's Manual

MH-400SH0 Material Handler

Model No. 44930—Serial No. 313000001 and Up

Model No. 44931—Serial No. 313000001 and Up

Model No. 44933—Serial No. 313000001 and Up

Model No. 44934—Serial No. 313000001 and Up



This product complies with all relevant European directives, for details please see the separate product specific Declaration of Conformity (DOC) sheet.

Electromagnetic Compatibility

Domestic: This device complies with FCC rules Part 15. Operation is subject to the following two conditions: (1) This device may not cause harmful interference and (2) this device must accept any interference that may be received, including interference that may cause undesirable operation.

This equipment generates and uses radio frequency energy and if not installed and used properly, that is, in strict accordance with the manufacturer's instructions, may cause interference to radio and television reception. It has been type tested and found to comply with the limits for a FCC Class B computing device in accordance with the specifications in Subpart J of Part 15 of FCC Rules, which are designed to provide reasonable protection against such interference in a residential installation. However, there is no guarantee that interference will not occur in a particular installation. If this equipment does cause interference to radio or television reception, which can be determined by turning the equipment off and on, the user is encouraged to try to correct the interference by one or more of the following measures: Reorient the receiving antenna, relocate the remote control receiver with respect to the radio/TV antenna or plug the controller into a different outlet so that the controller and radio/TV are on different branch circuits. If necessary, the user should consult the dealer or an experienced radio/television technician for additional suggestions. The user may find the following booklet prepared by the Federal Communications Commission helpful: "How to Identify and Resolve Radio-TV Interference Problems". This booklet is available from the U.S. Government Printing Office, Washington, DC 20402. Stock No. 004-000-00345-4.

FCC ID: LOBSBU200-Base, LOBSHH200-Hand Held
IC: 7955A-SBU200-Base, 7955A-SHH200-Hand Held

Operation is subject to the following two conditions: (1) this device may not cause interference, and (2) this device must accept any interference, including interference that may cause undesired operation of the device.

identifies the location of the model and serial numbers on the product. Write the numbers in the space provided.

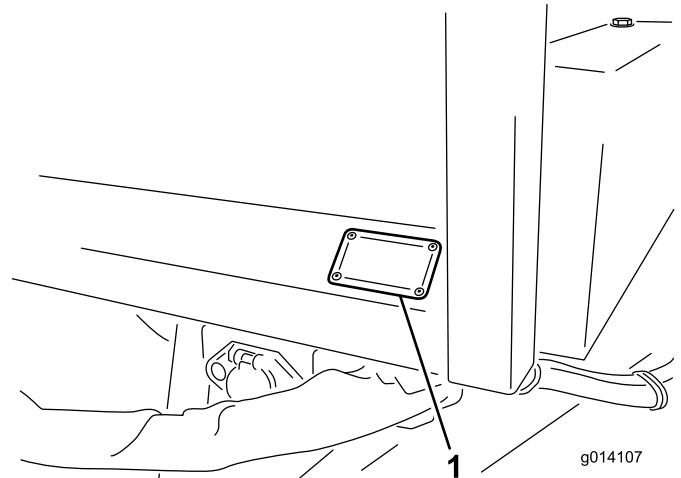

Figure 1

1. Model and serial number location

<p>Model No. _____</p> <p>Serial No. _____</p>
--

This manual identifies potential hazards and has safety messages identified by the safety alert symbol (Figure 2), which signals a hazard that may cause serious injury or death if you do not follow the recommended precautions.

Introduction

This MH-400 is intended to be used by professional, hired operators in commercial applications. It is primarily designed for transporting, metering and dispersing materials, under a range of moisture conditions, without clogging or drastically affecting the dispersion.

Read this information carefully to learn how to operate and maintain your product properly and to avoid injury and product damage. You are responsible for operating the product properly and safely.

You may contact Toro directly at www.Toro.com for product and accessory information, help finding a dealer, or to register your product.

Whenever you need service, genuine Toro parts, or additional information, contact an Authorized Service Dealer or Toro Customer Service and have the model and serial numbers of your product ready. Figure 1



Figure 2

1. Safety alert symbol

This manual uses 2 other words to highlight information. **Important** calls attention to special mechanical information and **Note** emphasizes general information worthy of special attention.

Contents

Introduction.....	2	Premaintenance Procedures.....	40
Safety	4	Lubrication.....	40
Before Operating	4	Safety Checks	41
While Operating.....	4	Hydraulic System.....	42
Maintenance.....	6	Changing Tires	42
Safety and Instructional Decals	7	Tracking the Conveyor Belt.....	42
Setup	10	Tensioning the Conveyor Belt	43
1 Installing the Hitch	11	Changing the Conveyor Belt	43
2 Installing the Weight Case	11	Adjusting the Conveyor Drive Chain.....	45
3 Adjusting the Mirror	12	Maintaining the Electric Brakes.....	45
4 Attaching the Hydraulics to the Tow Vehicle	12	Inspecting the Electric Brakes	45
5 Installing the Wiring for the Tow Vehicle	13	Adjusting the Electric Brakes	45
6 Installing the Tow Vehicle Brake Components (Models 44931 & 44934 only).....	14	Inspecting the Brake Shoes and Linings.....	46
7 Setting the Electric Brake Adjustments	15	Yearly Brake Cleaning and Inspection.....	46
8 Installing the EH Wireless Control Mounting Bracket On the Tow Vehicle.....	15	Brake Lubrication.....	46
Product Overview	17	Inspecting the Magnets.....	46
Controls	17	Storage.....	47
Specifications	18	Troubleshooting.....	48
Attachments/Accessories.....	18	Schematics	50
Operation.....	18		
Connecting the MH-400 to the Tow Vehicle	18		
Disconnecting the MH-400 from the Tow Vehicle	20		
E-Stop button	20		
Operating the Hydraulic Control Valves on SH Models	20		
Operating the Hydraulic Controls and Options on EH Models.....	21		
Operation.....	25		
Floor Start.....	26		
Option Start	27		
All Start.....	28		
Store or Change the All Start Speed Setting (ALL STORE)	30		
Setting the Preset 1, 2, and 3 Buttons	30		
To Operate in Preset Mode	30		
Battery Life, BUMPS, Operating Frequency, Base & Remote ID Display	30		
Loading Material	30		
Unloading Material.....	31		
Twin Spinner Operation	32		
Cross Conveyor/Swivel Operation	36		
Operating the Cross Conveyor.....	38		
Operating the Swivel Kit.....	39		
Maintenance.....	40		

Safety

Improper use or maintenance by the operator or owner can result in injury. To reduce the potential for injury, comply with these safety instructions and always pay attention to the safety alert symbol, which means **CAUTION, WARNING, or DANGER-**"personal safety instruction." Failure to comply with the instruction may result in personal injury or death.

Before Operating

- The machine has different balance, weight, and handling characteristics compared to some other types of pulled equipment. Read and understand the contents of this Operator's Manual before operating the machine. Become familiar with all controls and know how to stop quickly.
- Never allow children to operate the machine. Do not allow adults to operate the machine without proper instructions. Only trained and authorized persons should operate this vehicle. Anyone who operates the vehicle should have a motor vehicle license.
- Never operate the machine when under the influence of drugs or alcohol.
- Keep all shields and safety devices in place. If a shield, safety device or decal is illegible or damaged, repair or replace it before operation is commenced.
- Tighten any loose nuts, bolts and screws to assure machine is in safe operating condition. Make sure the machine tongue mounting pins, hitch pins and tongue jack are in place and secure.
- Do not modify this equipment in any manner.
- Do not operate machine while wearing sandals, tennis shoes, sneakers or shorts. Also, do not wear loose fitting clothing which could get caught in moving parts. Always wear long pants and substantial shoes. Wearing safety glasses, safety shoes and a helmet is advisable and required by some local ordinances and insurance regulations.
- The capabilities of the machine may vary depending on the size and type of tow vehicle.
 - For best results, use a tow vehicle with at least 45 hp and four wheel drive. A tow vehicle with less than 45 hp will limit where you can go and how much payload you can deliver. For example, a 27 hp tow vehicle can tow a fully loaded machine over flat terrain, but not on steep hills. A four wheel drive will also improve performance on hills.
 - With a smaller tow vehicle, you may need to reduce the payload to 2.6 cubic yards (2 cubic meters) of material for spreading in difficult terrain. Another option is to tow a fully loaded machine to a spot near the job and then load smaller machines from the machine to complete the job.
 - For best results, use a tow vehicle with a fixed displacement hydraulic pump with a power output of 2,000 psi @ 10 gal/min (138 bar @ 38 L/min). Performance will be reduced if pump output is less.
 - When fully loaded, the machine can weigh up to 15,432 lb (7,000 kg). Do not go beyond the limitations of the tow vehicle.
 - Ensure that the tow vehicle has enough power and traction to pull a full load. If not, reduce the size of loads.
 - The tow vehicle must have an adequate hitch and functional brakes.
- The tongue is the area on the machine where the hitch connects to the tow vehicle. The weight of the tongue affects the stability of the machine.
 - When the tongue's weight is forced up into the hitch of the tow vehicle, this produces a negative tongue weight. Negative tongue weight may also result when options are mounted on the rear of the machine.
 - When the tongue's weight is forced down onto the hitch of the tow vehicle, this produces a positive tongue weight.
 - A negative or positive tongue weight can cause injury when connecting or disconnecting the machine to the tow vehicle. Ensure that the jack stands are properly engaged.
 - To balance the tongue weight, raise or lower the rear of the machine by 4-6 inches (10-15 cm). However, be aware that raising the machine can increase the risk of tipping.

While Operating

- Do not run the engine in a confined area without adequate ventilation. Exhaust fumes are hazardous and could possibly be deadly.
- NEVER carry passengers on the machine and keep everyone away from the areas of operation.
- Keep hands and feet out of hopper when unit is operating or engine is running on tow vehicle.

- Operator should remain seated whenever the tow vehicle is in motion.
- Using the machine demands attention. Failure to operate tow vehicle safely may result in an accident, tip over of tow vehicle and serious injury or death. Drive carefully. To prevent tipping or loss of control:
 - Use extreme caution, reduce speed and maintain a safe distance around sand traps, ditches, creeks, ramps, any unfamiliar areas or other hazards.
 - Watch for holes or other hidden hazards.
 - Use caution when operating tow vehicle on a steep slope. Normally travel straight up and down slopes. Reduce speed when making sharp turns or when turning on hillsides. Avoid turning on hillsides whenever possible.
 - Use extra caution when operating tow vehicle on wet surfaces, at higher speeds or with a full load. Stopping time will increase with a full load. Shift into a lower gear before starting up or down a hill.
 - Avoid sudden stops and starts. Do not go from reverse to forward or forward to reverse without coming to a complete stop.
 - Do not attempt sharp turns or abrupt maneuvers or other unsafe driving actions that may cause a loss of control.
 - Before backing up, look to the rear and assure no one is behind. Back up slowly.
 - Watch out for traffic when near or crossing roads. Always yield the right of way to pedestrians and other vehicles. This machine is not designed for use on streets or highways. Always signal your turns or stop early enough so other persons know what you plan to do. Obey all traffic rules and check for local regulations on the operation of the machine on or near highways.
 - Always watch out for and avoid low over hangs such as tree limbs, door jambs, over head walkways, etc. Make sure there is enough room over head to easily clear the tow vehicle and your head.
 - Lightning can cause severe injury or death. If lightning is seen or thunder is heard in the area, do not operate the machine; seek shelter.
 - If ever unsure about safe operation, STOP WORK and ask your supervisor.
 - Do not leave the machine unattended while it is running
 - Do not get the wireless controller on the EH model wet.
- You can load the machine from the top or the rear. When loading from the rear, raise or remove the rear gate.
- Ensure that the machine is connected to the tow vehicle before loading.
- Do not carry loads that exceed the load limits of the machine or the tow vehicle.
- The stability of loads can vary—for example, high loads have a higher center of gravity. Reduce the maximum load limits to ensure better stability, if necessary.
- To avoid causing the machine to tip over:
 - Carefully monitor the height and weight of the load. Higher and heavier loads can increase the risk of tipping.
 - Distribute the load evenly, front to back and side to side.
 - Be careful when turning and avoid unsafe maneuvers.
 - Always ensure that the machine is connected to the tow vehicle before loading.
 - Do not put large or heavy objects into the hopper. This could damage the belt and rollers. Also ensure that the load has a uniform texture. Small rocks in sand can become projectiles.
- Do not stand behind the machine when unloading or spreading. The twin spinner, cross conveyor and processor eject particles and dust at a high speed.
- Do not unload the machine or disconnect it from the tow vehicle while on a hill.
- Ensure that the machine is connected to the tow vehicle before unloading.
- Always remove options before loading or unloading the machine from a trailer. Otherwise, the option may hit the ramp or ground and be seriously damaged.
- The machine is designed only for off road use. The maximum recommended speed without a load is 15 mph (24 km/h), and 8 mph (13 km/h) with a full load.
- Before operating the machine, raise the front jack and rear jack leg. Remove the jack from the jack leg and store it on the tongue during operation.
- Maintain safe control of the machine. Do not attempt abrupt maneuvers or other unsafe actions, especially on hills or uneven ground.
- Ensure that the cross conveyor is centered. Traveling with it in the extended position can damage the option attachment brackets and swivel kit.

- Do not travel with the machine in the fully raised position. This increases the risk of tipping over.
- Before operating the machine, raise the front jack and rear jack leg. Remove the jack from the jack leg and store it on the tongue during operation
- Maintain safe control of the machine. Do not attempt abrupt maneuvers or other unsafe actions, especially on hills or uneven ground.
- The machine has a safe range for traveling with options attached as shown by the green section in the decal.
- Do not travel with the machine in the caution range (yellow/black). When no options attached, travel with the machine in lowered position.
- Always slow down when turning and avoid sharp turns. Otherwise, the machine may tip over.
- Heavy loads and wet or uneven surfaces increase the time it takes to stop, and reduce the ability to turn quickly and safely.
- Be aware of your surroundings when turning or backing up. Ensure that the area is clear and keep all bystanders at a safe distance. Proceed slowly.
- Turn off the option when approaching people, vehicles, vehicle crossings, or pedestrian crossings.
- The mirror mounted on the front of the hopper allows you to monitor the load and the spreading action. Check the mirror frequently to monitor the operation of the machine.
- Do not operate the machine with the weight case removed or out of position.
- Use extreme caution when traveling on hills, especially when turning.
 - Traveling across steep hills with the unit fully loaded could result in tipping over, or a loss of traction for the machine or tow vehicle.
 - Always travel straight up and down hills—do not travel sideways or diagonally. When traveling down a hill, do not exceed the speed at which you can travel up the same hill. Stopping distance increases when traveling down hills.
 - Reduce the weight of the load when traveling on steep hills, and avoid piling the load high.
 - When using an option, be aware that the machine has only 6 inches (15 cm) of ground clearance. When the machine begins to travel up a hill the ground clearance decreases.
- Park the machine on a firm, level surface. Avoid soft ground because the jack leg could sink and cause the machine to tip over.
- Do not disconnect the machine from the tow vehicle on hills, or without engaging the front jack and rear jack leg.
- To rotate the front jack and rear jack leg from a vertical support position to a traveling horizontal position, pull out the jack stand support pin and swivel the front jack (pull out the rear jack leg) and secure it in the horizontal position.
- Ensure that the rear jack leg and the hopper are in the down position. Put a spacer (such as a piece of wood) underneath the rear leg when the gap to the ground exceeds 2 inches (5 cm).
- When disconnecting the machine, always block the wheels to prevent movement.

Maintenance

- Before servicing or making adjustments to the machine, stop engine of tow vehicle, set parking brake and remove key from engine to prevent accidental starting of the engine.
- Before doing any maintenance work under the hopper, install the hydraulic cylinder supports.
- Perform only those maintenance instructions described in this manual. If major repairs are ever needed or assistance is desired, contact an Authorized TORO Distributor.
- Be sure machine is in safe operating condition by keeping nuts, bolts and screws tight.
- Make sure all hydraulic line connectors are tight, and all hydraulic hoses and lines are in good condition before applying pressure to the system.
- Keep body and hands away from pin hole leaks in hydraulic lines that eject high pressure hydraulic fluid. Use cardboard or paper to find hydraulic leaks. Hydraulic fluid escaping under pressure can penetrate skin and cause injury. Fluid accidentally injected into the skin must be surgically removed within a few hours by a doctor familiar with this form of injury or gangrene may result.
- To ensure optimum performance and safety, always purchase genuine TORO replacement parts and accessories to keep the Toro all TORO. NEVER USE "WILL FIT" REPLACEMENT PARTS AND ACCESSORIES MADE BY OTHER MANUFACTURERS. Look for the TORO logo to assure genuineness. Using unapproved replacement parts and accessories could void the warranty of The Toro Company.

Safety and Instructional Decals



Safety decals and instructions are easily visible to the operator and are located near any area of potential danger. Replace any decal that is damaged or lost.

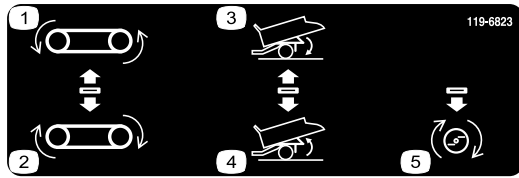

119-6823

SH models only

1. Reverse conveyor belt
2. Advance conveyor belt
3. Lower hopper
4. Raise hopper
5. Option on

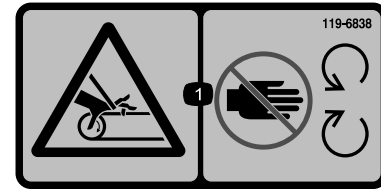

119-6838

1. Entanglement hazard, belt—stay away from moving parts, keep all guards and shields in place.



119-0217

1. Warning—stop the engine; stay away from moving parts; keep all guards and shields in place.



93-9899

1. Crushing hazard—install the cylinder lock.



115-2047

1. Warning—do not touch the hot surface.



93-9852

1. Warning—read the *Operator's Manual*.
2. Crushing hazard—install the cylinder lock.

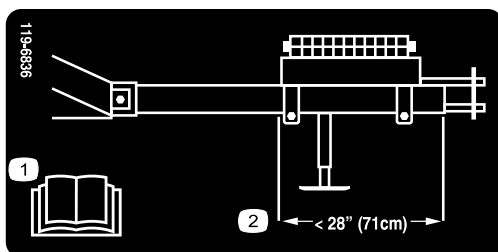

119-6836

1. Read the *Operator's Manual*.
2. Locate weight so that rear of the weight case is 28 in (71 cm) from the front face of hitch tube.

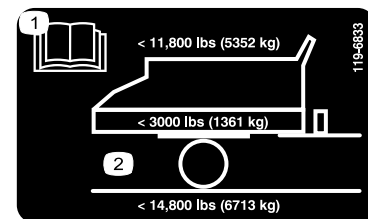

119-6833

1. Read the *Operator's Manual*.
2. Maximum load weight 11,800 lb (5,352 kg); vehicle weight 3,000 lb (1,361 kg), Maximum gross vehicle weight 14,800 lb (6,713 kg)



119-6806

1. Warning—read the *Operator's Manual*.
2. Warning—do not operate the machine unless you are trained.
3. Thrown object hazard—keep bystanders a safe distance from the machine.
4. Warning—stop the engine, remove the ignition key and read the *Operator's Manual* before performing maintenance on the machine.
5. Warning—no riders on machine.
6. Warning—stay away from moving parts; keep all guards and shields in place.

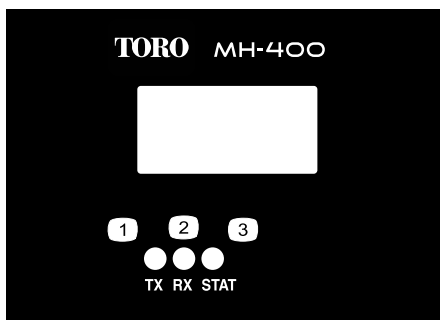

119-6837

EH models only

1. TX
2. RX
3. STAT

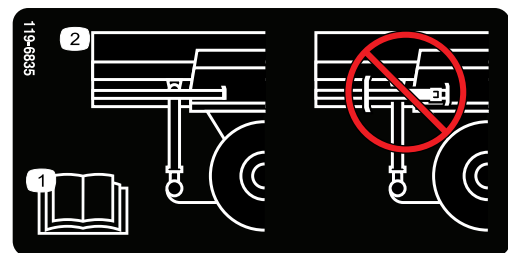

119-6835

1. Read the *Operator's Manual*.
2. Do not store the jack on rear leg.

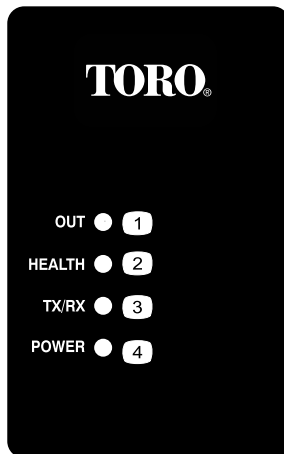

119-6830

EH models only

1. Out
2. Health
3. TX/RX
4. STAT

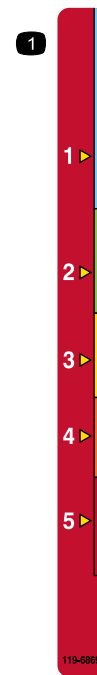

119-6869

1. Tailgate height adjustment



119-6822

1. Belt
2. On
3. Off

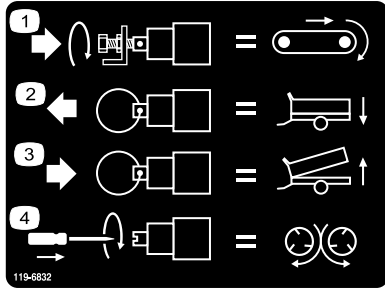

119-6832

1. Adjust floor speed
2. Lower the hopper
3. Raise the hopper
4. Adjust spinner speed

Setup

Loose Parts

Use the chart below to verify that all parts have been shipped.

Procedure	Description	Qty.	Use
1	Bolt, 1 x 6–1/2 inch Lock nut, 1 inch	2 2	Install the hitch
2	No parts required	–	Install the weight case
3	No parts required	–	Adjust the mirror
4	No parts required	–	Attach the hydraulics to the tow vehicle
5	SH Pendant (models 44930 & 44931) SH Wire harness (models 44930 & 44931) EH Wire harness (models 44933 & 44934) Bracket (models 44933 & 44934) Screw, 5/16 x 1 inch (models 44933 & 44934) Nut, 5/16 inch (models 44933 & 44934) Screw, 1/4 x 1 inch (models 44933 & 44934) Nut, 1/4 inch (models 44933 & 44934)	1 1 1 1 2 2 2 2	Install the wiring for the tow vehicle
6	Foot controller Load controller Harness assembly Socket bracket Screw, 5/16 x 1 inch Nut, 5/16 inch Wire splices Cable tie Screw, #10 x 2 inch Nut, #10 Hose clamp	1 1 1 1 4 4 6 10 2 2 1	Install the tow vehicle brake components (Models 44931 & 44934 only)
7	No parts required	–	Set the electric brake adjustments
8	Mounting bracket assembly Backing plate Flange head bolt, 5/16 x 1–1/2 inch Flange head lock nut, 5/16 Wireless controller with magnet	1 1 4 4 1	Install the EH wireless control mounting bracket on the tow vehicle (Models 44933 & 44934 only)

Media and Additional Parts

Description	Qty.	Use
Operator's Manual	1	Read before operating.
Parts Catalog	1	Use to lookup parts.
Declaration of Conformity	1	
Attachment clamps	2	Use to mount attachments

Note: Determine the left and right sides of the machine from the normal operating position.



Installing the Hitch

Parts needed for this procedure:

2	Bolt, 1 x 6-1/2 inch
2	Lock nut, 1 inch

Procedure

1. Locate and remove the loose parts box shipped on the fender.
2. Remove the rear support leg from the shipping position and place it in the down position.
3. Remove the hitch from the shipping position by cutting both straps securing the hitch to the fender (Figure 3). Remove both mounting brackets from the fender and discard.

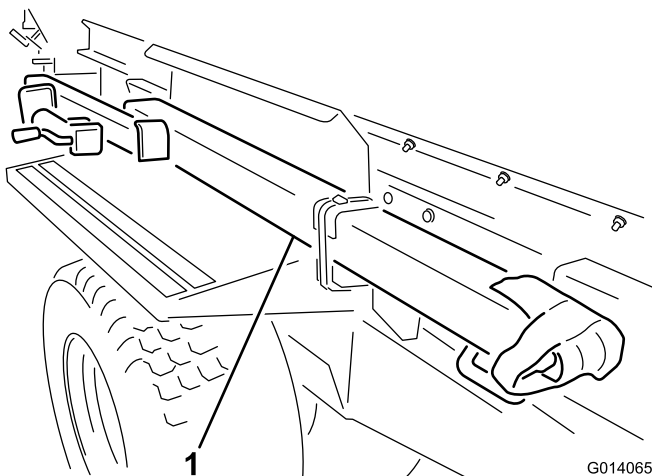

Figure 3

1. Remove hitch from shipping position

Note: Two people are required to remove the hitch assembly.

4. Slide the hitch tube tongue into place at the front of the machine. Ensure that the jack mounting bracket faces out towards the left side.
5. Place one 1 x 6-1/2 inch bolt through the frame and hitch tube and install the lock nut (Figure 4).
6. Place the second 1 x 6-1/2 inch bolt through the top of the frame and down through the hitch tube. Install the lock nut (Figure 4).

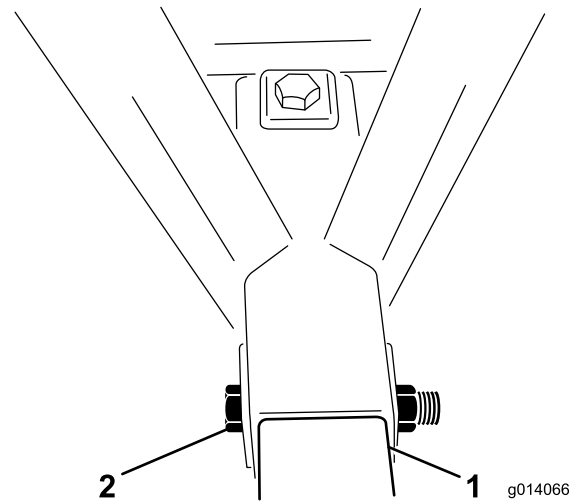

Figure 4

1. Hitch tube
2. Mounting bolt and nut

7. Remove the jack assembly from the rear leg. Install the jack assembly onto the hitch tube, placing the pin horizontally.

Note: Do not place the pin through the top hole of the jack, or you will not be able to remove the pin when the weight case is secured to the hitch.

2

Installing the Weight Case

No Parts Required

Procedure

1. Remove the weights from the weight case.
2. Remove the 1/2 x 5-1/2 inch bolts from the mounting bracket holding the weight case. Discard the mounting brackets (Figure 5).

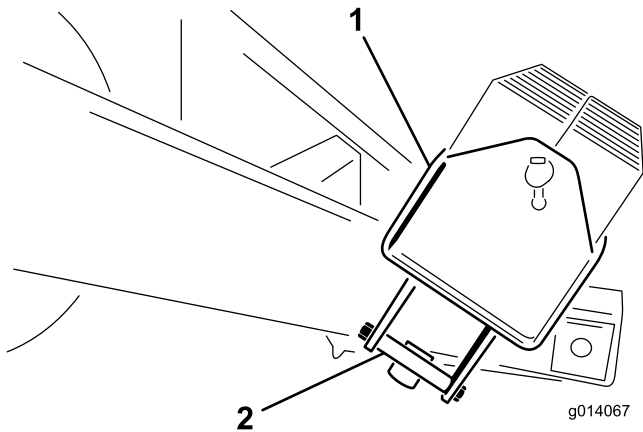

Figure 5

1. Weight case
2. Weight case mounting bracket

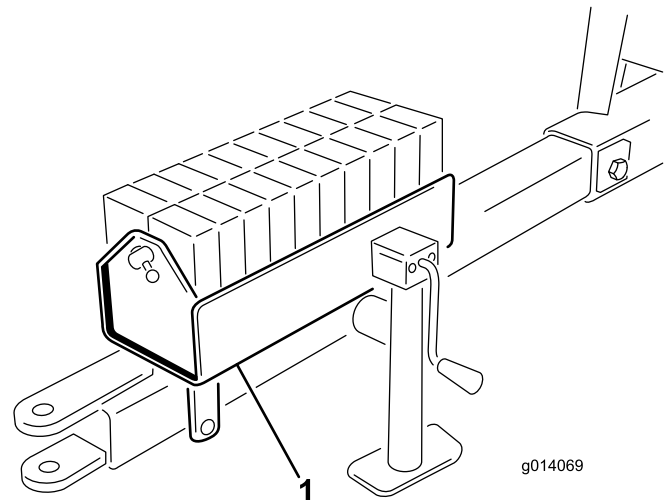

Figure 6

1. Fill weight case

3

Adjusting the Mirror

No Parts Required

Procedure

Adjust the mirror (Figure 7) so when the operator is seated he can view the inside of the hopper.

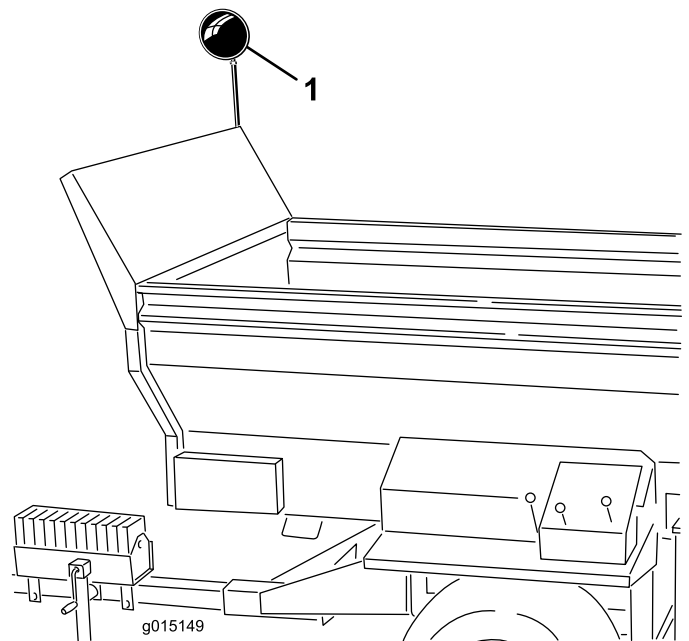

Figure 7

1. Mirror

4

Attaching the Hydraulics to the Tow Vehicle

No Parts Required

Procedure

Note: The tow vehicle must be equipped with an open center auxiliary hydraulic valve.

Connect the two hydraulic hoses from the machine to the tow vehicle. Facing the front of the machine, connect the right hose to the pressure side and the left hose to the return side (Figure 8). The return hose has an in line one way check valve. Also, there is an arrow on the check valve which should face toward the tow vehicle.

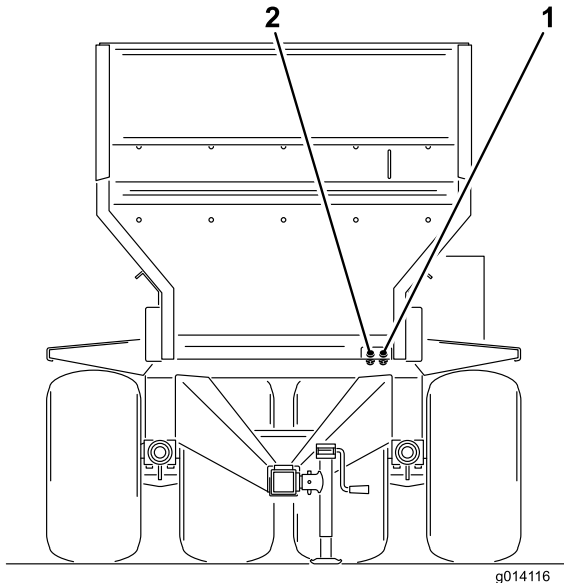

Figure 8

1. Pressure in 2. Return out

Important: The hydraulic hoses and the power cable must not drag on the ground when operating the machine. Avoid locations where they could become pinched or cut.

5

Installing the Wiring for the Tow Vehicle

Parts needed for this procedure:

1	SH Pendant (models 44930 & 44931)
1	SH Wire harness (models 44930 & 44931)
1	EH Wire harness (models 44933 & 44934)
1	Bracket (models 44933 & 44934)
2	Screw, 5/16 x 1 inch (models 44933 & 44934)
2	Nut, 5/16 inch (models 44933 & 44934)
2	Screw, 1/4 x 1 inch (models 44933 & 44934)
2	Nut, 1/4 inch (models 44933 & 44934)

Procedure

SH Models

1. Run the battery wiring harness through the tow vehicle and up to the battery.
2. Connect the fused wire to the positive connector and the other wire to the ground to the battery.
3. Attach the SH battery wiring harness to the solenoid wiring harness coming from the base unit. The connector is located among the hydraulic hose attached to the tow vehicle.
4. On SH models plug the on/off pendant switch (4 prong end) into the socket at the front left corner of the machine (Figure 9).

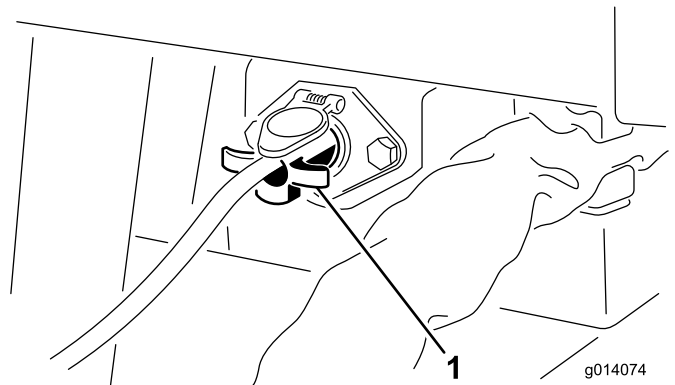

Figure 9

1. On/off pendant switch (SH Models)

5. Ensure that all the hose connections and wire harnesses are installed correctly and tightened.

Important: Always remove the on/off pendant switch cord or disconnect the power supply wire when the machine and tow vehicle are not in use. Otherwise, the tow vehicle battery will lose power.

6

Installing the Tow Vehicle Brake Components (Models 44931 & 44934 only)

Parts needed for this procedure:

1	Foot controller
1	Load controller
1	Harness assembly
1	Socket bracket
4	Screw, 5/16 x 1 inch
4	Nut, 5/16 inch
6	Wire splices
10	Cable tie
2	Screw, #10 x 2 inch
2	Nut, #10
1	Hose clamp

Procedure

Note: Lay out the harness on the tractor to determine the mounting locations of the harness components. Cable ties are supplied to retain any surplus cable lengths. Also, wire splices are provided if the length of the harness have to be altered (shortened or lengthened). Heat the shrink connectors until they shrink tight onto the wires.

Important: If length is added to the harness, make sure to use the proper gauge wire.

1. Mount the socket bracket to the rear of the tow vehicle with two 5/16 x 1 inch screws and nuts.
2. Route the wire harness connector through the hole to the socket. Slide the boot down the harness if the connector does not go through the hole.
3. Bolt the wire harness, with the socket connector, to the rear of the socket bracket with two 5/16 x 1 inch screws and nuts.
4. Route the harness along the tow vehicle.
5. Mount the load controller to the tractor dash or the fender with the (2) #10 screws and #10 nuts.
6. Using the hose clamp, secure the foot controller to the pad on the tow vehicle brake pedal.
7. Connect the harness to the components (Figure 11) as follows:

EH Models

1. Mount the socket bracket to the rear of the tow vehicle with (2) 5/16 x 1 inch screws and nuts.
2. Route the wire harness connector through the hole to the socket. Slide the boot down the harness if the connector does not go through the hole.
3. Secure the wire harness socket to the bracket with (2) 1/4 x 1 inch screws and nuts (Figure 10).
4. Connect the fused wire to the positive connector and the other wire to the ground to the battery.
5. Attach the base unit wiring harness to the tow vehicle wiring harness (Figure 10). The connector is located among the hydraulic hose attached to the tow vehicle.

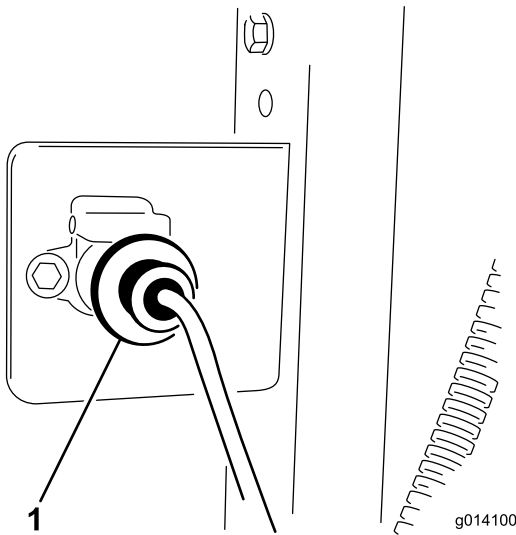

Figure 10

1. Attach Battery Harness to Solenoid Harness

6. Ensure that all the wire harnesses are installed correctly and tightened.

- Plug the shorter wire from the harness into the foot controller wire connector.
- Connect the longer wire from the harness to the load controller wire connector.
- Connect the ring terminal wire, **without a fuse**, to the negative (-) battery terminal.
- Connect the other ring terminal wire, **with a fuse**, to the positive (+) battery terminal.

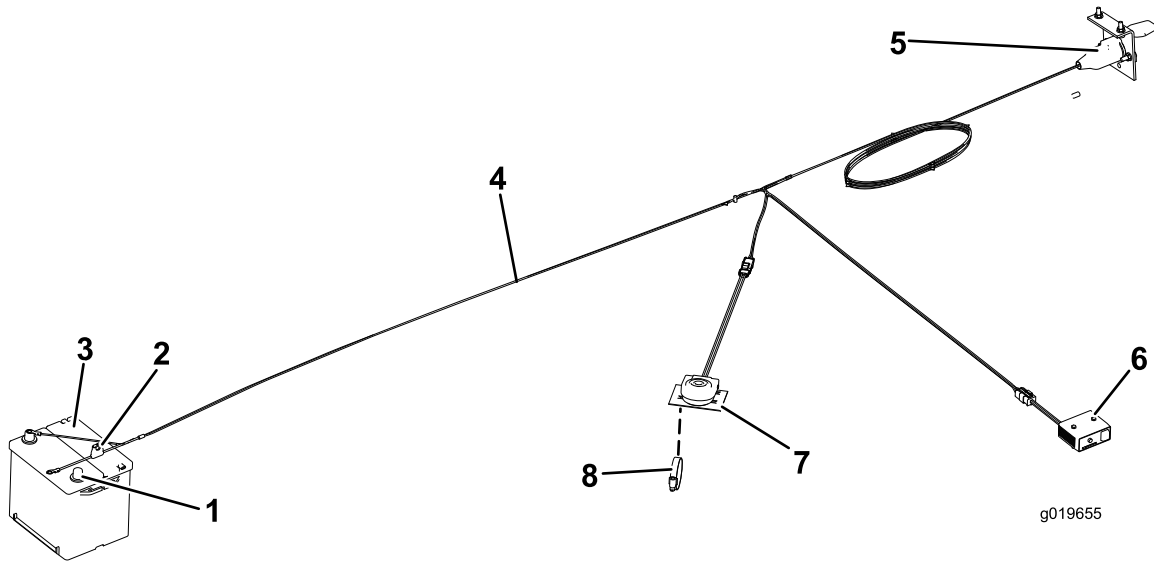

Figure 11

- | | |
|--|--|
| <ol style="list-style-type: none"> 1. Positive battery terminal (+) 2. Negative battery terminal (-) 3. Fuse 4. Wire harness | <ol style="list-style-type: none"> 5. Socket connector 6. Load controller 7. Foot controller 8. Hose clamp |
|--|--|

8. Secure the rubber boot to the connector and to the wire harness with a cable tie.
9. Secure all loose harness wires with cable ties.
10. A 10 amp fuse is included in the harness. If using a 4 wheel brake kit, replace the 10 amp fuse with the provided 15 amp fuse.

7

Setting the Electric Brake Adjustments

No Parts Required

Procedure

Before operating the machine for the first time, the electric brakes must be synchronized to the tow vehicle's brakes (so that they operate at the same time).

The machine and the tow vehicle will seldom have the correct amperage flow to the brake magnets to provide comfortable, safe braking. Changing the load weight, as

well as uneven alternator and battery output, can result in unstable current flow to the brake magnets.

The Load Control compensates for trailer load variations by limiting the maximum torque output of the brakes by adding dropping resistance in the electrical control line. When towing a trailer loaded to brake rated capacity, the Load Control must be set at maximum braking. When pulling an empty or partially loaded trailer, the Load Control must be set between maximum and minimum braking at a position just before the point at which trailer tire skidding occurs when actuating the hand control fully on. Failure to install and use the Electric Load Control will result in excessive brake torque when stopping a trailer loaded to less than brake capacity.

8

Installing the EH Wireless Control Mounting Bracket On the Tow Vehicle

Parts needed for this procedure:

1	Mounting bracket assembly
1	Backing plate
4	Flange head bolt, 5/16 x 1-1/2 inch
4	Flange head lock nut, 5/16
1	Wireless controller with magnet

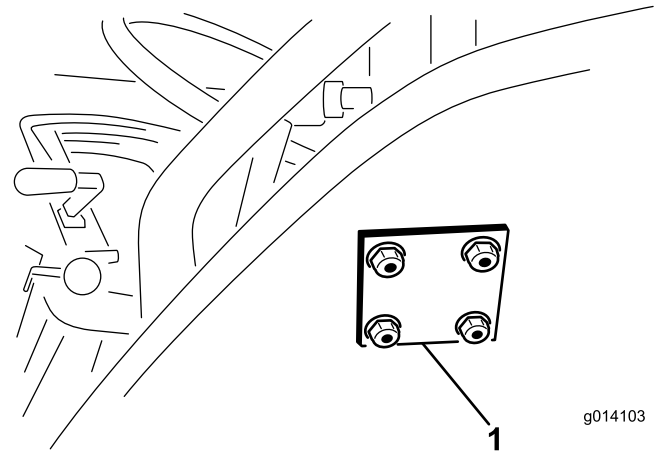

g014103

Figure 13

1. EH wireless control backing Plate

Procedure

1. Remove the wireless control and mounting bracket from the packaging.
2. For Tow Vehicle mounting, determine an appropriate location for the wireless control mounting bracket. The surface should be flat and solid.
3. Using the backing plate as a template, locate, mark and drill (4) 11/32 inch diameter holes in the tow vehicle mounting surface.
4. Attach the mounting bracket and backing plate with (4) 5/16 x 1-1/2 inch flange head bolts and flange locknuts (Figure 12 and Figure 13).

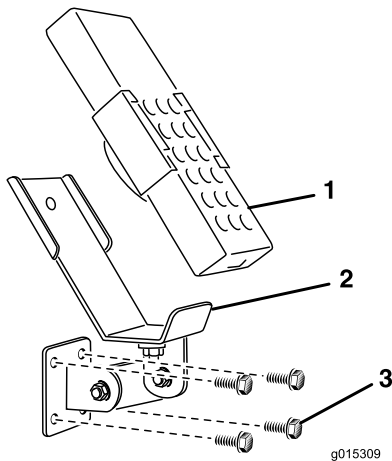

Figure 12

1. Wireless controller
2. EH Wireless controller mount
3. Mounting bolts

Product Overview

Controls

Hydraulic Control Valves (SH Models)

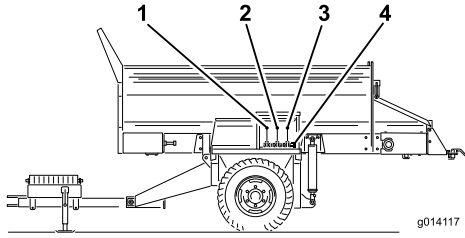

Figure 14

1. Conveyor belt direction (left control valve)
2. Raise and lower machine (center control valve)
3. Options on and off (right control valve)
4. Option hydraulic quick connectors

Left Valve

The left valve controls the machine conveyor belt direction (Figure 14).

Center Valve

The center valve raises and lowers the machine (Figure 14).

Right Valve

The right valve controls the option (Figure 14).

Option Hydraulic Quick Connectors

Connect the option hydraulic here (Figure 14).

E-Stop button

When finished working with the MH-400, always press the E-Stop button (Figure 15) to disable the electrical system. When beginning work with the MH-400 you must pull the E-Stop button back out before turning on the controller.

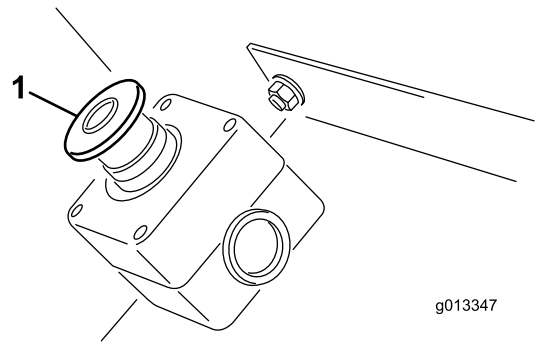

g013347

Figure 15

1. E-Stop Button

Wireless Controller (EH models)

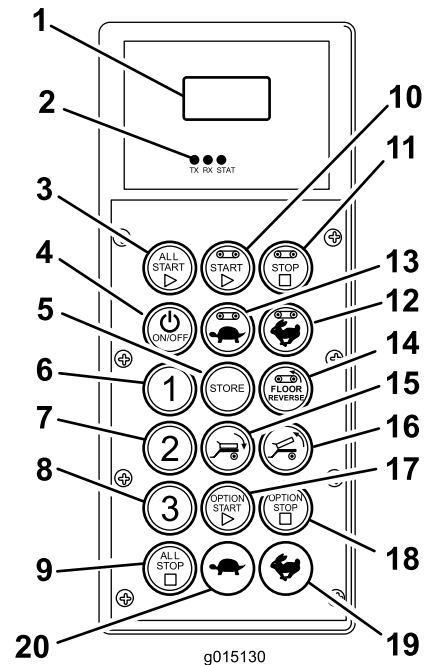

g015130

Figure 16

- | | |
|---------------------------------------|----------------------------|
| 1. LCD Display | 11. Stop: Floor |
| 2. Controller Status LED's | 12. Increase Speed: Floor |
| 3. All Start: Starts Floor and Option | 13. Decrease Speed: Floor |
| 4. On/Off | 14. Reverse: Floor |
| 5. Store: Saves Preset Settings | 15. Tilt Bed Down |
| 6. Preset 1 | 16. Tilt Bed Up |
| 7. Preset 2 | 17. Start: Option |
| 8. Preset 3 | 18. Stop: Option |
| 9. All Stop: Stops all functions | 19. Increase Speed: Option |
| 10. Start: Floor | 20. Decrease Speed: Option |

Specifications

Weights	
Models 44930 and 44933	3,527 lb. (1,600 kg)
Models 44931 and 44934	3,794 lb. (1,721 kg)

Wireless Controller Specifications	
Handheld Unit Operating Temperature Range	-4°F to 131°F (-20°C to 55°C)
Handheld Unit Storage Temperature Range-4°F to 131°F	-4°F to 131°F (-20°C to 55°C)
Base Unit Operating Temperature Range	-4°F to 158°F (-20°C to 70°C)
Base Unit Storage Temperature Range	-40°C to 85°C (-40°F to 185°F)
Humidity	0 to 100%
Vibration	IEC60068-2-6 10Hz TO 150Hz @ 1.0g Peak Acceleration
Shock	10g Peak Shock Acceleration

Radio	
Frequency	2.4GHz
Modulation	Direct Sequence Spread Spectrum
Antenna	Internal

Power	
Handheld Unit Power Source	4 x Type AA Alkaline
Base Unit Power	12 - 14.4VDC

Attachments/Accessories

A selection of Toro approved attachments and accessories are available for use with the machine to enhance and expand its capabilities. Contact your Authorized Service Dealer or Distributor or go to www.Toro.com for a list of all approved attachments and accessories.

Operation

Connecting the MH-400 to the Tow Vehicle

1. Connect the MH-400 hitch to the tow vehicle using a 1 inch (25 mm) diameter safety approved hitch pin and safety clip (not supplied).

Important: Use a high strength hitch pin that is approved for tow vehicle hitches.

2. Adjust the hitch height by turning the jack stand handle to keep the machine level.
3. Lower the hitch using the jack stand.
4. When the full weight of the machine has been transferred to the tow vehicle's draw bar from the jack stand, pull the pin holding the jack stand in place.
5. Turn the jack stand 90 degrees counter clockwise until the bottom of the jack stand points to the rear of the machine. This is the traveling position.

⚠ CAUTION

Raise the jacks into the traveling position before towing the machine.

6. Connect the two hydraulic hoses from the machine to the tow vehicle. Facing the front of the machine, connect the right hose to the pressure side and the left hose to the return side (Figure 17). The return hose has an in line one way check valve. The arrow on the check valve should face the tow vehicle return connector.

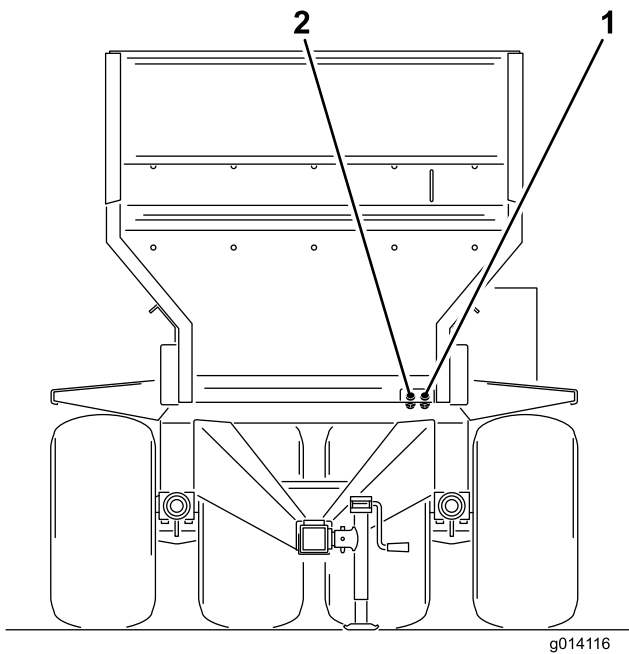

Figure 17

1. Pressure in 2. Return out

Important: The hydraulic lines, the power cable, and the pendant cables must not drag on the ground during operation. Avoid locations where they could become pinched or cut.

7. Connect the power harness to the tow vehicle (Figure 18 & Figure 19). On SH models place the on/off pendant within reach of the driver's seat. Ensure that the switch is off.

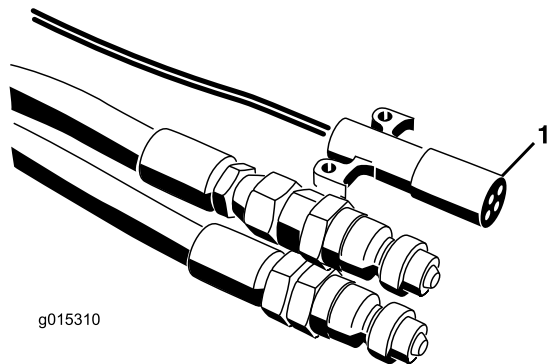

Figure 18

1. EH Power harness

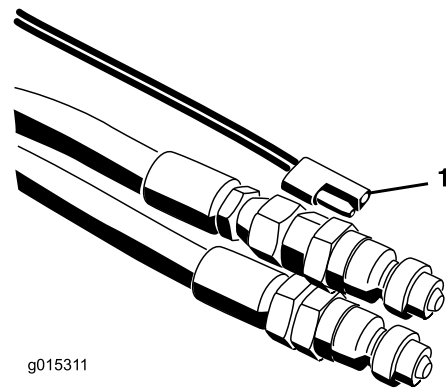

Figure 19

1. SH Power harness

8. Connect the coiled, power cable to the socket on the machine and the tow vehicle.
9. Check the hydraulic oil level in the tow vehicles tank and add more to fill it, if necessary. (See the tow vehicle's Owner's Manual).
10. Test the hydraulics before operating the machine for the first time.
11. Set the electric brake (if so equipped) as follows:
 - Before operating the machine for the first time, the electric brakes must be synchronized to the tow vehicle's brakes (so that they operate at the same time).
 - The machine and the tow vehicle will seldom have the correct amperage flow to the brake magnets to provide comfortable, safe braking. Changing the load weight, as well as uneven alternator and battery output, can result in unstable current flow to the brake magnets.
 - The Load Control compensates for trailer load variations by limiting the maximum torque output of the brakes by adding dropping resistance in the electrical control line. When towing a trailer loaded to brake rated capacity, the Load Control must be set at maximum braking. When pulling an empty or partially loaded trailer, the Load Control must be set between maximum and minimum braking at a position just before the point at which trailer tire skidding occurs when actuating the hand control fully on. Failure to install and use the Electric Load Control will result in excessive brake torque when stopping a trailer loaded to less than brake capacity.

▲ CAUTION

If you hear a noise from the tow vehicle hydraulics and the machine controls do not operate, the hoses have been connected incorrectly and must be reversed.

Note: You may have to relieve the pressure in the hoses of the machine connecting to the tow vehicle, to ensure a completed connection.

Important: When making sharp turns, the hydraulic hoses may contact the tow vehicle wheels. Avoid making sharp turns, if necessary, use a bungee cord (a rubber strap with hooks on both ends) to pull back the hoses towards the center.

Disconnecting the MH-400 from the Tow Vehicle

1. Park the tow vehicle and the machine on dry, level ground.
2. Set the parking brake on the tow vehicle, shut off the engine, and remove the key.
3. Place blocks under the front and back of the wheels.
4. Disconnect the coiled, power cable from the socket on the machine and on the tow vehicle.
5. Relieve the pressure from the hydraulic system.
6. Disconnect the hydraulic hoses and the electrical connection from the tow vehicle. Coil and store them on the front of the machine.
7. On SH models, disconnect and remove the control pendant for dry storage. On EH models, store the wireless controller in a dry safe place. Make sure the red button, located on the valve cover on the rear left side of the machine, is depressed.
8. Turn the front jack and rear jack leg 90 degrees (clockwise) to the down position to support the machine.
9. Lift the machine with the jack until the weight is off the tow vehicle's draw bar. Pull out the hitch pin.
10. Ensure that there is no further connection between the machine and the tow vehicle.

E-Stop button

When finished working with the MH-400, always press the E-Stop button (Figure 20) to disable the electrical system. When beginning work with the MH-400, you must pull the E-Stop button back out before turning on the controller.

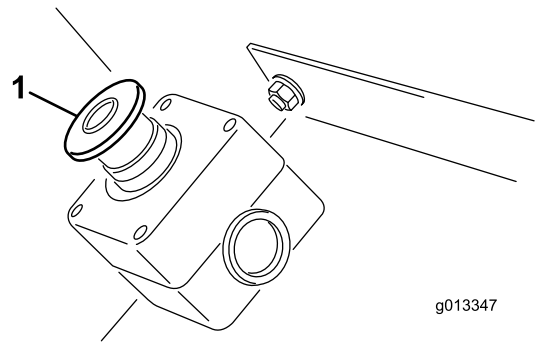

Figure 20

1. E-Stop Button

Important: When done operating the MH-400, press the E-Stop button to prevent the tow vehicle battery from being discharged.

Operating the Hydraulic Control Valves on SH Models

There are three hydraulic control valves located on the left fender of the machine (Figure 21).

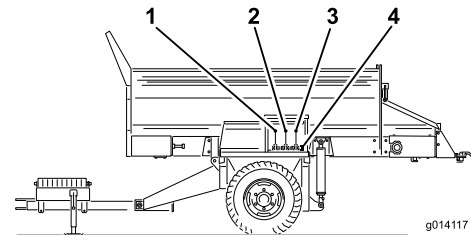

Figure 21

1. Conveyor belt direction (left control valve)
2. Raise and lower machine (center control valve)
3. Options on and off (right control valve)
4. Option hydraulic quick connectors

Note: Return all control valve handles to their center position after use to avoid unintended starting.

Left Valve

The left valve controls the machine conveyor belt direction.

- To unload the machine, pull the control lever toward you. This moves material to the rear along the conveyor belt.
- To load the machine, push the control lever away from you. This moves material to the front along the conveyor belt.
- To stop the conveyor belt, move the control lever to the center position.

Center Valve

The center valve raises and lowers the machine.

- To raise the machine, pull on the control lever until the desired height is reached, then release it.
- To lower the machine, push on the control until the desired height is reached, then release it.

⚠ CAUTION

Do not keep holding the control lever in the raised or lowered position once the lift cylinders have reached their maximum travel position.

Right Valve

The right valve controls the option.

- To turn on the option, pull on the control lever.
- To turn off the option, return the control lever to the center position.

⚠ WARNING

Pushing the control lever does not have any function. Options cannot be reversed.

Important: Do not pull the option lever into the on position without an option mounted. This can damage the floor motor and stop the machine.

Operating the Hydraulic Controls and Options on EH Models

Remote Control System

The Remote Control System consists of a Handheld Remote, a +12 to +14.4VDC Base Unit, and a wiring harness. The system is specifically designed to be used with and to control a MH-400 Material Handler.

Handheld Remote

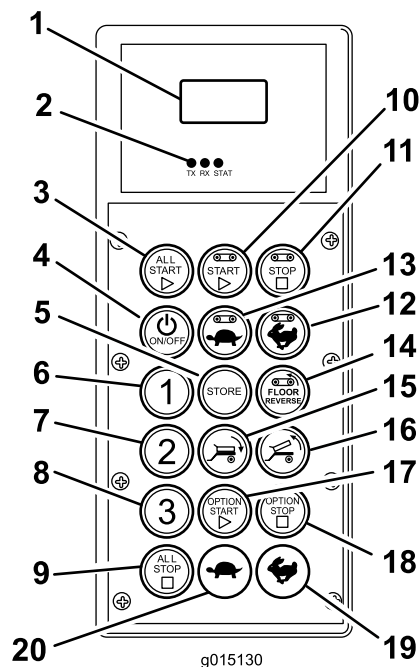

















Figure 22

- | | |
|---------------------------------------|----------------------------|
| 1. LCD Display | 11. Stop: Floor |
| 2. Controller Status LED's | 12. Increase Speed: Floor |
| 3. All Start: Starts Floor and Option | 13. Decrease Speed: Floor |
| 4. On/Off | 14. Reverse: Floor |
| 5. Store: Saves Preset Settings | 15. Tilt Bed Down |
| 6. Preset 1 | 16. Tilt Bed Up |
| 7. Preset 2 | 17. Start: Option |
| 8. Preset 3 | 18. Stop: Option |
| 9. All Stop: Stops all functions | 19. Increase Speed: Option |
| 10. Start: Floor | 20. Decrease Speed: Option |

Button Functions

Button	Name	Primary Function
	ON/OFF	Power controller on and off.
	ALL START	Provides functional control on both the Floor and Option including on/off and speed.
	FLOOR START	Provides functional control of the hopper conveyor floor belt including on/off and floor speed.
	STOP FLOOR	Stops the Floor.
	FLOOR DEC	Decreases the Floor speed.
	FLOOR INC	Increases the Floor speed.
	FLOOR REVERSE	Momentary button that reverses the Floor direction. Reverse floor speed can be modified using the Floor increase and Floor decrease speed buttons while pressing the Floor Reverse button. Upon release of the Floor Reverse button, the Floor turns OFF.
	TILT BED DOWN	Momentary button for lowering the bed.
	TILT BED UP	Momentary button for raising the bed.
	PRESET 1 PRESET 2 PRESET 3	Three separate Preset values may be stored for both FLOOR and OPTION are speeds.
	STORE	Used in conjunction with the Preset button to store or establish a Preset memory.
	OPTION START	Provides functional control of the rear Option including on/off and option speed.
	OPTION STOP	Stops the Option.
	OPTION DEC	Decreases the Option speed.
	OPTION INC	Increases the Option speed.
	ALL STOP	Stops both Floor and Option.

E-Stop Button

When finished working with the MH-400, always press the E-Stop button (Figure 23) to disable the electrical system. When beginning work with the MH-400, you must pull the E-Stop button back out before turning on the controller.

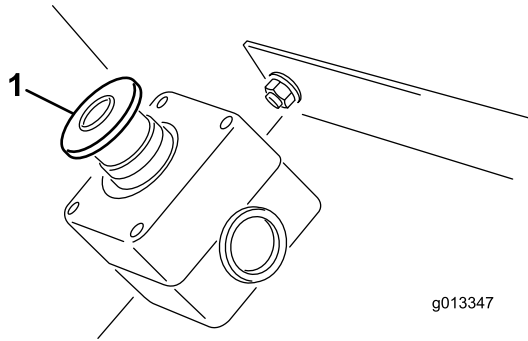

Figure 23

1. E-Stop Button

To Power On

Press the controller's On/Off button and wait for the hand held to find the base. Ensure that there are no buttons being pressed on the hand held while it is performing its start up routine.

Manual Override

Should the controller ever be lost, damaged or fail the MH-400 functions and operation are still possible in order to complete tasks or continue work until the problem is resolved.

The override access is on the driver side of the hydraulic system (Figure 24).

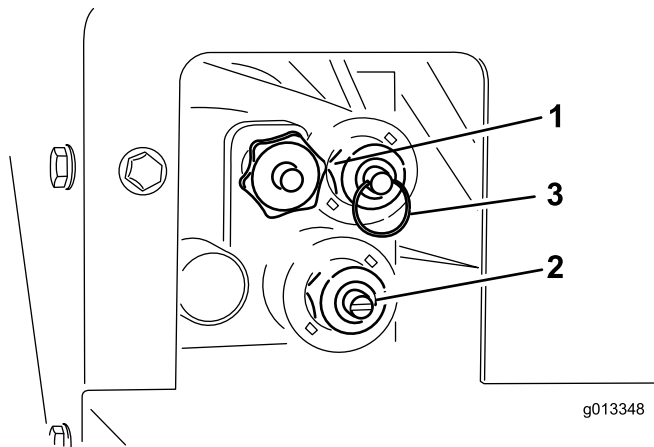

Figure 24

1. Floor speed
2. Raise/lower hopper
3. Spinner speed

To adjust the floor speed (Figure 24), turn the knob clockwise. Maximum floor speed is used in the Color-Coded Operating System so this adjustment can be made while no hydraulic flow is present. This is most relevant when you have a hopper full of sand.

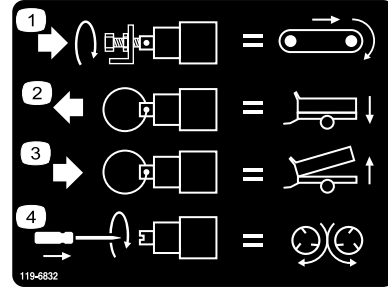

Figure 25

1. Adjust floor speed
2. Lower the hopper
3. Raise the hopper
4. Adjust spinner speed

To raise the hopper (Figure 24), pull out on the ring on the valve stem.

To lower the hopper (Figure 24), push in on the ring on the valve stem.

To adjust the spinner speed (Figure 24), use a flat-head screwdriver to increase by turning clockwise or decrease by turning counter clockwise.

If adjusting with hydraulic flow active, ensure the floor is turned off if you do not wish to have sand being spread as you adjust.

Once your settings are acceptable, use the hydraulic flow control on your tow vehicle to turn the system on and off for operation.

Power Up Safety Feature

Upon power up, the Handheld Remote checks for all switches to be **OFF**. If any switches are found to be **ON**—a stuck switch—the display will show **SW STUCK** and the name of the switch that is at fault displays. The Handheld Remote will not send any commands to the Base Unit until the stuck switch is released and OFF.

The Base Unit also evaluates the initial incoming message and makes sure that all commands are clear before any outputs are allowed to be controlled.

Key Functionality Elements

- When the controller is first powered on, the display should read “FLR OFF and OPT OFF” in approximately 5 seconds. If the words “waiting

for base” are in the display, check to ensure there is electrical power to the base unit and ensure the E-Stop button on the base unit is pulled out.

- There is always a **current working memory**. This is not the same as a preset. The last saved work settings will be in the current working memory when the controller is powered on.
- Operational sequence of the controller start buttons:
 - Pressing a start button once (All Start, Floor Start or Option Start) calls up the current working memory setting stored in the controller
 - By pressing the same start button a second time the component is activated if the hydraulics are not engaged (it shows numbers ramping up in display), or the component is turned on if the hydraulics are engaged.
 - Pressing the same start button a third time will store the new setting established in the controller’s working memory.
- After pressing a start button once to view the current working memory setting in a non-working mode, there is approximately 10 seconds to begin adjusting the setting or the element will revert back to OFF. In a working mode, the 10 second rule is gone.
- To program a preset, the key to remember is the elements must be **activated or engaged**.
- To operate from a preset, the element speed percentages must be in the display to activate or engage them. If the words OFF are in the display, the preset must be recalled.

Liquid Crystal Display (LCD)

The two line, 8 character per line LCD (Liquid Crystal Display) shows status and activity as the Remote buttons are pressed. It features user adjustable backlighting and contrast. Changes are saved in the Remote current working memory. When the unit is turned on after being powered down, the last settings for Contrast and Backlighting are used for the display.



Please use the button references in Figure 2 Handheld Remote Front Panel Layout when adjusting Contrast and Backlighting.

To Increase the Contrast:



Hold the ALL STOP  and the OPTION

INCREASE  buttons simultaneously while observing the display until the contrast is as desired.



To Decrease the Contrast:

Hold the ALL STOP  and the OPTION DECREASE  buttons simultaneously while observing the display until the contrast is as desired.

To Increase the Backlighting:

Hold the ALL STOP  and the FLOOR INCREASE  buttons simultaneously while observing the display until the backlighting is as desired.

To Decrease the Backlighting:

Hold the ALL STOP  and the FLOOR DECREASE  buttons simultaneously while observing the display until the backlighting is as desired.

Note: Decreasing the Backlighting to zero effectively turns it off. Backlighting consumes the most energy of all Handheld Remote functions. Increasing the backlighting increases power consumption and will shorten the life span of the batteries; the lower the backlighting, the longer the battery life span.

Status LEDs

Two LEDs, a Green (Transmit) and Amber (Receive) are used to indicate Handheld Remote activity.

GREEN LED:

A flashing Green LED indicates a message is being transmitted to the Base Unit.

A solid Green LED indicates a Handheld Remote button is pressed.

AMBER LED:

A flashing AMBER LED indicates a message is being received from the Base Unit.

A solid AMBER LED indicates one or more Base Unit outputs are active.

Power

The Handheld Remote is powered by four factory installed 1.5V AA Alkaline batteries and operates between 1.6 to 3.2V. Battery life expectation is approximately 300 hours (continuous operation, backlight off), but battery life longevity is affected by usage factors, particularly backlight intensity setting—the higher the backlight setting, the more power consumed resulting in shorter battery life.

Note: It is recommended that fresh spare batteries be at hand at all times that the system is in use.

Note: At some point, the Handheld Remote may sense that the voltage is at the low threshold (approximately 1.7V) at which the display will show the message LOW BATTERY. The message will cycle with the current display message at periodic intervals while the unit is used. When displayed, the operator has a limited time – approximately ten (10) hours – to power down the system before the remote will automatically power down at which point the batteries must be replaced.

Batteries should be changed soon after the display shows the first low battery warning. The warning will periodically flash across the display as LOW BATTERY while the unit is in use. The Handheld Remote can be used for approximately ten (10) hours (assuming backlight is off) before ultimately powering down to a non operational condition at which time the batteries must be replaced with four (4) fresh AA alkaline batteries.

Install or Replace the Batteries

1. Place the Remote face down and remove the four screws holding the battery cover in place. Remove the battery cover.

Note: The four screws holding the battery cover in place are ‘captive’ to the cover—the cover holes are threaded. Although they are not easily removed from the cover itself, be aware that the screws if over loosened while opening the battery compartment can be completely removed increasing the risk of loss.

2. Remove the discharged batteries and properly dispose in accordance with local regulations.

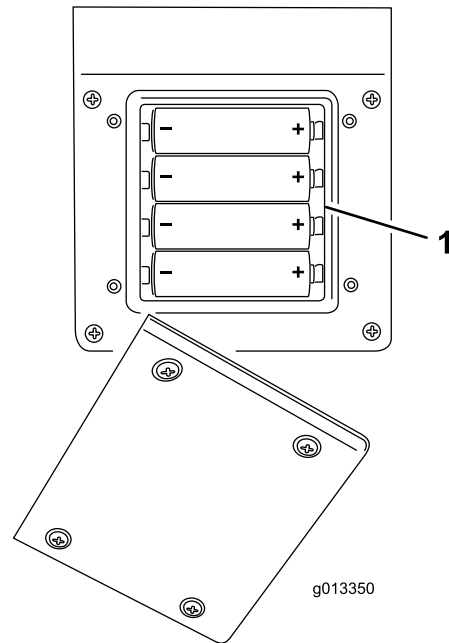

Figure 26

1. Battery Compartment

3. Plug each fresh battery into a terminal cradle observing proper polarity. (If the batteries are improperly installed, the unit will not be damaged, but it will fail to operate.) The cradle is embossed with polarity markings for each terminal—emphasized in Figure 3 - 4 AA Alkaline Battery Compartment below. Make sure they are firmly seated in the unit.
4. Replace the battery cover. Secure the cover with the four screws. Make sure they are tightened enough to compress the seal, but be careful not to over tighten.

Handheld Remote Care

Though the Handheld Remote is rugged, care should be taken not to drop the unit onto hard surfaces. To clean the Remote, use a soft cloth moistened with water or a mild cleaning solution to wipe it paying particular attention to avoid scratching the LCD (Liquid Crystal Display) screen.

Operation



Base↔Remote Communication

Communication between the Base and Handheld Remote units must be established before the system can be used. This link process is called Association and it is performed while the Handheld Remote is in Associate Mode.

Association between Remote and Base Unit is established at the factory; however, there may be instances in the field when a Handheld Remote and a Base Unit must be reassociated. When necessary, Association can be performed as described below.

Associate Mode (Remote ↔ Base Unit Association)

1. Press the E-Stop button to remove power from the base unit and make sure the handheld is OFF.
2. Stand near the base unit in clear line of sight.
3. Simultaneously press and continue to hold the

ON/OFF  and the ALL STOP  buttons. The Handheld Remote goes through its initialization screens and settles on **ASSOC PENDING**.

4. Continue to hold both buttons and then quickly release them when **ASSOC ACTIVE** is displayed (approximately four (4) seconds).

Note: If the buttons are pressed to long, **WAITING FOR BASE** will be displayed.

5. Release the two buttons. The displays will show **CLR CHAN SCAN**. The Handheld Remote scans all available channels and chooses the channel with the least traffic.

6. Press and hold the **STORE** button . The Handheld will display **POW UP BUNIT**. Continue to hold the **STORE** button.

7. Pull out on the E-Stop button to power up the Base Unit. The Handheld will Associate (link) with the Base Unit. Upon success, the display will show **ASSOC SUCCESS**.

8. Release the **STORE** button.

Note: The Handheld Remote and Base Unit link can

be viewed by holding down the ALL STOP  and

OPTION STOP  buttons at the same time. The display will cycle and indicate the selected channel and the ID of the Base Unit.

Floor Start

Upon initially pressing Floor Start (where the floor is not running), the Handheld display shows the stored setting and during this time an OFF command is continuously sent to the Base Unit to ensure the output remains **OFF**. In this preview mode, an S is displayed after **FLR– FLRS** is displayed—indicating the Handheld is in a **SET ONLY** mode. In this preview

mode, the setting can be adjusted up or down as desired using the Increase Floor Speed and Decrease Floor Speed buttons, but the actual output at the Base Unit remains OFF. This is useful as it allows the operator to pre set a desired floor speed setting, or use the stored setting, without causing unwanted movement. Upon settling on a desired speed, the FLOOR START button can be pressed again causing the Base Unit output to ramp to the chosen setting. Pressing FLOOR START for a third time causes the current value to be stored in memory.

Note: Changes to the Floor settings while the Floor is running are immediately effective, but they are temporary unless the setting is stored. For instance, an adjustment is made while the display shows FLRS, the Floor is started ramping to the adjusted setting, and then the Handheld Remote is turned off (powered down) without storing the change. The setting will revert to the previously stored value when the next time the Handheld Remote is used.

Note: A ten (10) second timer starts when the FLOOR

START  button is pressed and FLFS (SET ONLY mode) displays. If a button press is not sensed during the ten second interval, the display reverts to FLR and the previous state/value displays and is enforced. The timer resets to ten seconds if any button is pressed while the Handheld is in the SET ONLY mode.

Change or Store Floor Speed Setting



The starting speed for the Floor can be changed at will. When changed, the new value is not stored in the

current working memory unless the ALL START  button

or FLOOR START  button is pressed again while the Floor is active. The stored value is



used any time thereafter when the ALL START  button is pressed or when the START FLOOR is pressed. To change the value

1. Press the FLOOR START  button. The preview value displays.
2. Adjust the command to the desired speed setting





using the INCREASE FLOOR SPEED  button or the DECREASE FLOOR SPEED  button while watching the display.

3. Press the FLOOR START  button again to start the Base Unit Floor Output.
4. Press FLOOR START  button once more (the third time).

The LCD acknowledges the new stored command by displaying FLOOR STORE. This value is used

when either the FLOOR START  or ALL START  button is pressed.

Alternate Store Floor Command Setting Method

1. Press the ALL START  button to display the preview or SET ONLY mode (FLS and OPTS).
2. Adjust the command to the desired speed using the FLOOR Increase  or FLOOR Decrease  button.
3. Press the ALL START  button again to run the Floor and Option.
4. Press the ALL START  button while both Floor and Option are running. The display acknowledges the new stored commands with ALL STORE.

Note: Both Floor and Option must be running for ALL STORE to work. If only one or neither are

running, the ALL START  command will be interpreted as a request to either start them both, or to start the one that was not running. Nothing is stored and the commands previewed are the previously stored Floor and the Option commands. It is important to realize that the stored command for the Floor is used twice, once in the event of an

individual command using FLOOR START ,

and once in the event of a combined action using ALL START ; in either case, it is the same number.

Option Start

Upon initially pressing OPTION START  (where the Option is not running), the Handheld display shows the stored setting and during this time an OFF command is continuously sent to the Base Unit to ensure the output remains OFF. In this preview mode, an S is displayed after **OPT—OPTS** is displayed—indicating the Handheld is in a **SET ONLY** mode. In this preview mode, the setting can be adjusted up or down as desired using the Increase Floor Speed and Decrease Floor Speed buttons, but the actual output at the Base Unit remains OFF. This is useful as it allows the operator to pre set a desired option speed setting, or use the stored setting, without causing unwanted movement. Upon settling on a desired speed, the OPTION START button can be pressed again causing the Base Unit output to ramp to the chosen

setting. Pressing OPTION START  for a third time causes the current value to be stored in the current working memory.

Note: Changes to the Option setting while the Option is running are immediately effective, but they are temporary unless the setting is stored. For instance, an adjustment is made while the display shows OPTS, the Option is started ramping to the adjusted setting, and then the Handheld Remote is turned off (powered down) without storing the change. The setting will revert to the previously stored value the next time the Handheld Remote is used.



Note: A ten (10) second timer starts when the







OPTION START  button is pressed and OPTS (SET ONLY mode) displays. If a button press is not sensed during the ten second interval, the display reverts to OPT and the previous state/value displays and is enforced. The timer resets to ten seconds if any button is pressed while the Handheld is in the SET ONLY mode.

Change or Store the Option Speed Setting





The starting speed for the Option output can be changed at will. When changed, the new value is not stored in the current working memory unless the

OPTION START  button or ALL START  button is pressed again while the Option is active. The stored value is used any time thereafter when the ALL

 is pressed or when the  OPTION START is pressed. To change the value:



1. Press the  OPTION START button. The preview value displays.
2. Adjust the command to the desired speed setting using the  OPTION INCREASE SPEED button or the  OPTION DECREASE SPEED button while watching the LCD.
3. Press the  OPTION START button again to start the Base Unit Option Output.
4. Press the  OPTION START button once more. The LCD acknowledges the new stored command by displaying OPTION STORE. This value is used when either the  OPTION START or  ALL START button is pressed.

Alternate Store Option Command Setting Method

1. Press the  ALL START button to display the preview or SET ONLY mode (FLS and OPTS).
2. Adjust the command to the desired speed using the  OPTION Increase or  OPTION Decrease button.
3. Press the  ALL START button again to run the Option and Floor.
4. Press the  ALL START button while both Option and Floor are running. The display acknowledges the new stored commands with ALL STORE .

Note: Both Floor and Option must be running for ALL STORE to work. If only one or neither are running, the ALL START command will be interpreted as a request to either start them both, or to start the one that was not running. Nothing is stored and the commands previewed are the previously stored Floor and the Option commands.

Note: It is important to realize that the stored command for the OPTION is used twice, once in the event of an individual command using OPTION

 START, and once in the event of a combined action using  ALL START; in either case, it is the same number.

All Start

Upon initially pressing All Start (where the floor is not running), the Handheld display shows the stored setting and during this time an OFF command is continuously sent to the Base Unit to ensure the output remains **OFF**. In this preview mode, an S is displayed after **FLR- FLRS** and **OPT-OPTS** are displayed—indicating the Handheld is in a **SET ONLY** mode. In this preview mode, the setting can be adjusted up or down as desired using the Increase Floor or Option Speed and Decrease Floor or Option Speed buttons, but the actual output at the Base Unit remains OFF. This is useful as it allows the operator to pre set a desired floor speed setting, or use the stored setting, without causing unwanted movement. Upon settling on a desired speed, the ALL START button can be pressed again causing the Base Unit output to ramp to the chosen setting. Pressing ALL START for a third time causes the current value to be stored in memory.

Note: Changes to the Floor or Option settings while the Floor or Option is running are immediately effective, but they are temporary unless the setting is stored. For instance, an adjustment is made while the display shows FLRS, the Floor is started ramping to the adjusted setting, and then the Handheld Remote is turned off (powered down) without storing the change. The setting will revert to the previously stored value when the next time the Handheld Remote is used.

Note: A ten (10) second timer starts when the  ALL START button is pressed and FLFS (SET ONLY mode) displays. If a button press is not sensed during the ten second interval, the display reverts to FLR and the previous state/value displays and is enforced. The timer resets to ten seconds if any button is pressed while the Handheld is in the SET ONLY mode.



Change or Store Floor Speed Setting

The starting speed for the Floor can be changed at will. When changed, the new value is not stored in the current working memory unless the  ALL START

button or FLOOR START  button is pressed again while the Floor is active. The stored value is



used any time thereafter when the ALL START  is pressed or when the START FLOOR is pressed. To change the value

1. Press the FLOOR START  button. The preview value displays.
2. Adjust the command to the desired speed setting

using the INCREASE FLOOR SPEED  button or the DECREASE FLOOR SPEED  button while watching the display.



3. Press the FLOOR START  button again to start the Base Unit Floor Output.
4. Press FLOOR START  button once more (the third time).



The LCD acknowledges the new stored command by displaying FLOOR STORE. This value is used



when either the FLOOR START  or ALL START  button is pressed.

Change or Store the Option Speed Setting

The starting speed for the Option output can be changed at will. When changed, the new value is not stored in the current working memory unless the





OPTION START  button or ALL START  button is pressed again while the Option is active. The stored value is used any time thereafter when the ALL

START  is pressed or when the OPTION START  is pressed. To change the value:





1. Press the OPTION START  button. The preview value displays.
2. Adjust the command to the desired speed setting using the OPTION INCREASE SPEED 

button or the OPTION DECREASE SPEED

 button while watching the LCD.

3. Press the OPTION START  button again to start the Base Unit Option Output.
4. Press the OPTION START  button once more. The LCD acknowledges the new stored command by displaying OPTION STORE. This value is used when either the OPTION START  or ALL START  button is pressed.

Alternate Store Floor Command Setting Method

1. Press the ALL START  button to display the preview or SET ONLY mode (FLS and OPTS).
2. Adjust the command to the desired speed using the FLOOR Increase  or FLOOR Decrease  button.
3. Press the ALL START  button again to run the Floor and Option.
4. Press the ALL START  button while both Floor and Option are running. The display acknowledges the new stored commands with ALL STORE.

Note: Both Floor and Option must be running for ALL STORE to work. If only one or neither are

running, the ALL START  command will be interpreted as a request to either start them both, or to start the one that was not running. Nothing is stored and the commands previewed are the previously stored Floor and the Option commands. It is important to realize that the stored command for the Floor is used twice, once in the event of an



individual command using FLOOR START ,

and once in the event of a combined action using ALL START ; in either case, it is the same number.

Store or Change the All Start Speed Setting (ALL STORE)

Both the FLOOR and the OPTION must be running before the ALL STORE speed setting can be stored in memory.

Note: If only one or neither FLOOR and OPTION are running, the ALL START command will be interpreted as a request to start both, or to start the one that is not running while the other is running. Nothing is stored and the active command is the previously stored FLOOR command and the previously stored OPTION command.



1. Press the ALL START  button to start the FLOOR and the OPTION.
2. Set the desired speeds of both FLOOR and OPTION by using the appropriate Increase and Decrease speed buttons for each output.
3. Press the ALL START button  while the FLOOR and OPTION are running.

The LCD acknowledges the new regular command for both outputs by displaying ALL STORE.

Setting the Preset 1, 2, and 3 Buttons

Three Preset values that simultaneously affect both the FLOOR and the OPTION outputs are provided. Each Preset button acts essentially like a preview mode for the ALL START, except that they use different, user defined quick reference speed values. If the FLOOR and/or the OPTION happen to be running at the time the Preset is pushed, a preview value of both Floor and Option is displayed and if the ALL START button is then pressed the current operating values are replaced by the Preset values.

The user defined Preset values for PRESET 1, PRESET 2, and PRESET 3 are individually set as follows:

1. Start both FLOOR and OPTION either individually or by using the ALL START button .
2. Set the desired speeds of both FLOOR and OPTION by using the appropriate Increase and Decrease speed buttons for each output.
3. Press and hold the STORE  button and then press the PRESET button (1, 2, or 3).

Note: If STORE is held and a Preset button pressed while either FLOOR or OPTION are off, no new value is stored for either Floor or Option; the Preset holds the values previously stored.

To Operate in Preset Mode

To begin work or operate from a Preset mode do the following:

1. Press the desired Preset button (1, 2 or 3) to display the Floor and Option settings.
2. Press All Start, All Start to store the settings to the current working memory. Note: this will turn on the Floor and Option if the hydraulics are turned on.
3. Use the Start and Stop buttons to control the Floor and Option as desired

Battery Life, BUMPS, Operating Frequency, Base & Remote ID Display

Holding down the ALL STOP  and OPTION

 STOP buttons simultaneously results in display of multiple points of information. If the buttons remain held down, the display cycles approximately every two (2) seconds displaying first the battery life expectancy in percent remaining on line one, and BUMPS—Base Unit Messages Per Second—information on line two. The subsequent cycle displays the Operating Frequency (Channel) on which the units communicate, then the Handheld Remote ID number, followed by the associated Base Unit ID. Both handheld and base IDs are shown as hexadecimal values.

Loading Material

Load the machine from the top or from the rear.

For most materials, such as sand or gravel, you can use a front end bucket loader. For materials such as landscaping ties or fertilizer bags, load from the rear by placing the material on the conveyor belt and setting the hydraulics in the load position.

You may need to remove the rear gate for easier access.

If sacks of material are being used, empty the sacks into the loader's bucket before loading the material into the hopper. To ensure stability, distribute the load evenly, front to back and side to side.

Unloading Material

⚠ WARNING

Do not stand behind the machine while unloading

Bulk Unloading

1. Back the machine into the location where you want the material deposited.
2. Release the rear gate latches and turn on the conveyor belt.
3. If desired, raise the rear of the machine. This unloads material at a different angle, and allows quick unloading of the entire load.

Controlled Unloading

1. Close the rear gate latches.
2. Use the jack handle to open or close the adjustable section of the rear gate (Figure 27 and Figure 28). This restricts the flow of materials when using an option.

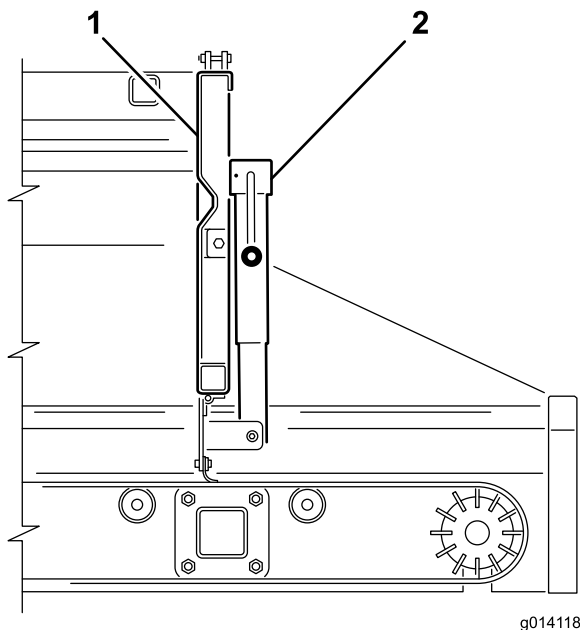

Figure 27

1. Rear gate
2. Feed gate jack

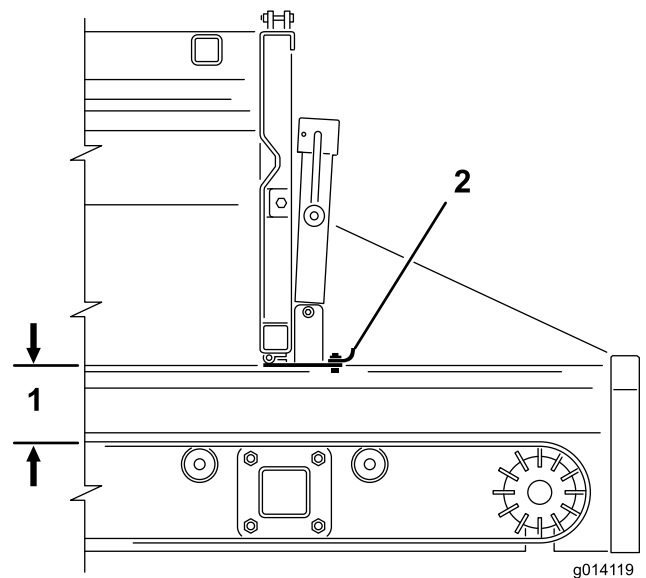

Figure 28

1. 5 inch (12.5 cm) maximum opening
2. Feed gate

Unloading Into Smaller Machines

1. Raise the rear of the machine high enough to accommodate the smaller machine underneath.
2. Follow the procedure for bulk unloading or controlled unloading.

⚠ CAUTION

Use the adjustable section of the rear gate only when unloading material smaller than 1 inch (25 mm) in diameter, such as sand or gravel.

⚠ CAUTION

Open the rear gate completely if material will not flow through the adjustable section. Test each new material first.

Twin Spinner Operation

Installing the Twin Spinner

The MH-400 comes equipped with a pair of quick attach mounting clamps. Use these clamps to mount the twin spinner to the MH-400.

1. Remove the safety latch clips from the clamp handles (Figure 29).
2. Lift the safety latch, then lift the option attachment clamp handles, and release the lock rings from the lock pins (Figure 29).
3. Slide the rear option attachment clamp assembly out of the quick attach slots (Figure 29).
4. With assistance, insert the front edge of the twin spinner up and under the rear of the MH-400 into the front clamps on the brackets (Figure 29).
5. While supporting the twin spinner, slide the rear option attachment clamp assembly back into the slots in the brackets, and over the rear edge (Figure 29).

6. Ensure that the twin spinner is centered between the brackets. Then re install the lock rings over the lock pins and push down on the clamp handles

Note: If the clamp assembly is too loose and the twin spinner slides within the clamps, turn the lock rings into the clamps a few turns until the twin spinner is secure.

Important: Do not over tighten the clamps. This may bend the edges of the twin spinner.

7. Reinstall the safety latch clips to the clamp handles (Figure 29).

⚠ CAUTION

Ensure that you reinstall the safety latch clips into the clamps. Otherwise, the clamps may open during operation.

⚠ WARNING

The options are heavy. Use an assistant to help lift the twin spinner.

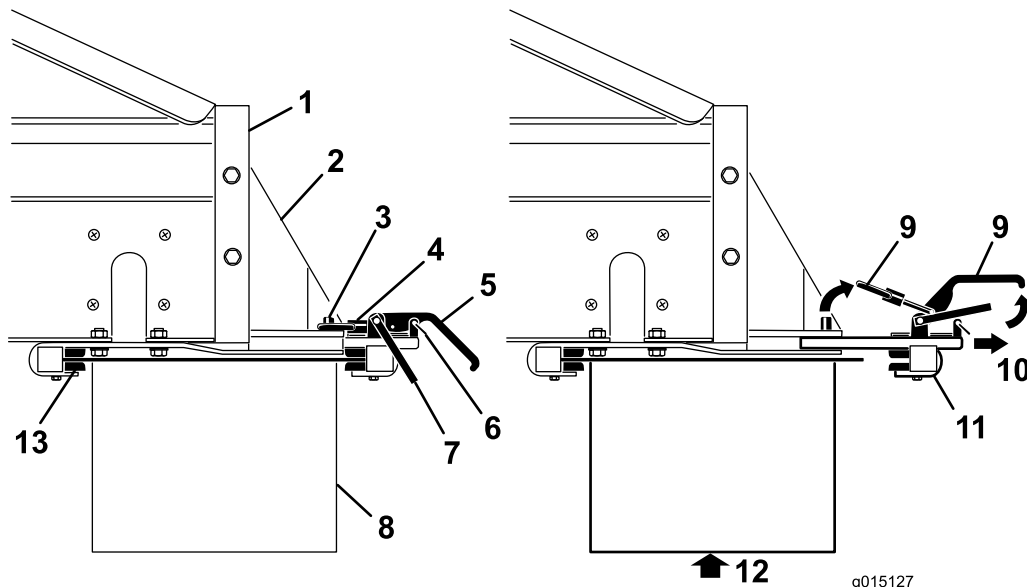

Figure 29

- | | | | |
|------------------------------|----------------------|---|--------------------------|
| 1. Rear of MH-400 | 5. Clamp handle | 9. Lift | 13. Front clamp brackets |
| 2. Option attachment bracket | 6. Safety latch clip | 10. Pull | |
| 3. Lock pin | 7. Safety latch | 11. Rear clamp assembly | |
| 4. Lock ring | 8. Option | 12. Support the option before removing the clamps | |

Connecting the Hydraulic Hoses

⚠ WARNING

Ensure that the tow vehicle is turned off before making the hydraulic connections, to prevent the cross conveyor/swivel from accidentally turning on.

Connect the hydraulic hoses to the option control valve on the MH-400 as follows (Figure 30):

- Pull back (or push forward) on the outer sleeve of the female connector and insert the male connector.

- Hold the male connector firmly in place and release the outer sleeve of the female connector.
- Ensure that the connectors are pushed all the way in and are securely locked in place.
- With the tow vehicle hydraulics operating, pull back on the option control lever on the SH models or start the option using the option start button on the wireless controller on the EH models, and ensure that the twin spinner is operating properly.

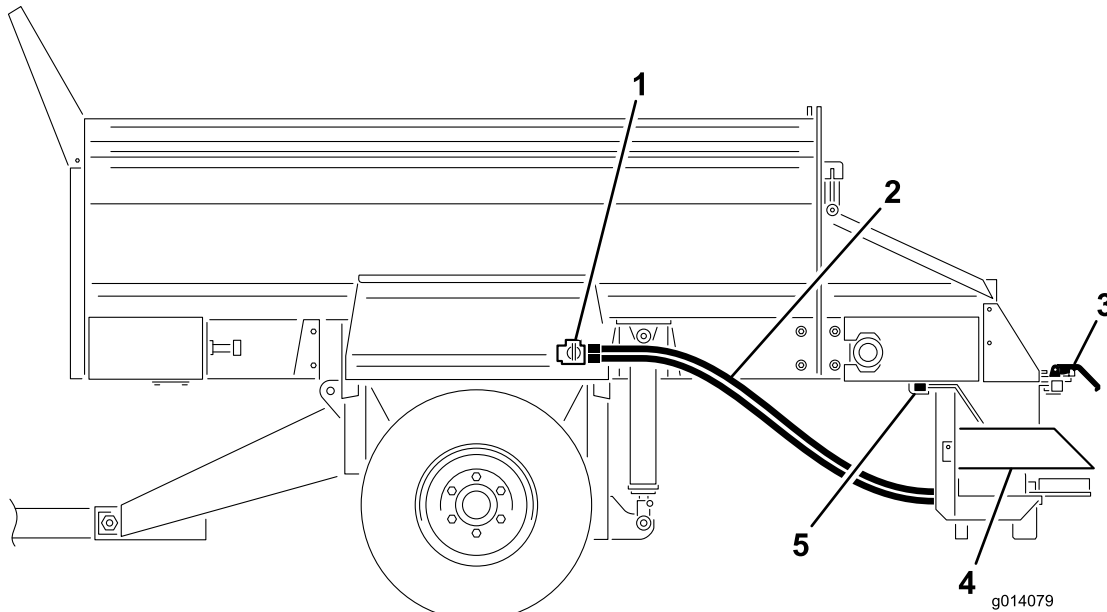

Figure 30

1. Option control valve
2. Hydraulic hoses
3. Quick attach clamps
4. Twin Spinner
5. Front clamp brackets

Setting the Desired Spread Pattern

Select the Desired Spread Pattern

- A-Ultra Light Pattern
- B-Light to Heavy Spread Pattern

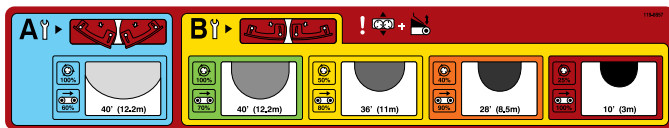

Figure 31

Note: For this example we will select **YELLOW**.

Setting the Drop Zone Position

1. Loosen the handle on each side of the twin spinner (Figure 32).

Note: The Twin Spinner is shipped from the factory in the “B” position.

Review the blade position and adjust the blades, if necessary.

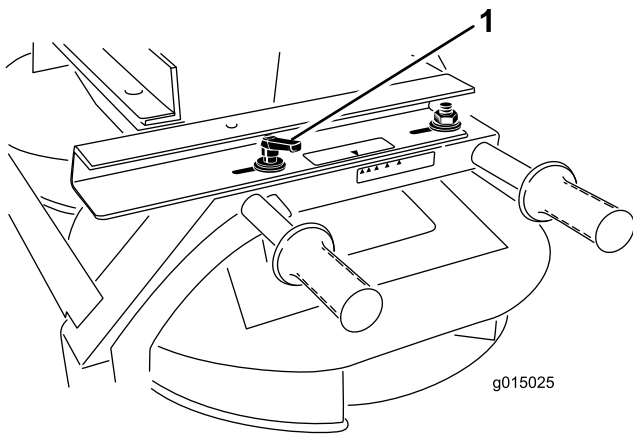

Figure 32

1. Handle

2. Slide the twin spinner, fore and aft, until the arrows match the desired color.
3. Tighten the handles.

Note: For this example we will select **YELLOW**.

Adjusting the Spinner Valve

MH-400 SH models

1. Loosen the knob securing the spinner valve lever (Figure 33).

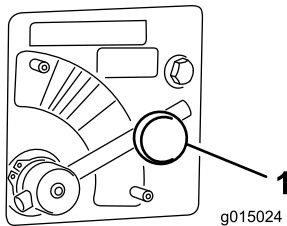

Figure 33

1. Spinner valve

2. Rotate the spinner valve lever to the desired color (Figure 33).

Note: For this example we will select **YELLOW**

MH-400 EH models

Move the spinner valve lever to the **BLUE** section (MAX SPEED) (Figure 33). Fully turned clockwise the lever should be horizontal.

Use the spinner percent listed on the spread pattern decal or the wireless remote decal to determine the value that is put into the wireless controller.

Note: For this example we will set the option percent to **50 percent** matching the yellow color spread pattern previously selected.

Adjusting the Hopper Gate and Belt Speed

MH-400 SH models

Rotate the crank to adjust the gate until the arrow aligns with the center of the **YELLOW** section which is number 3 (Figure 34).

The adjustment of the spread density will be controlled through the main hopper gate opening or through the tow vehicle speed.

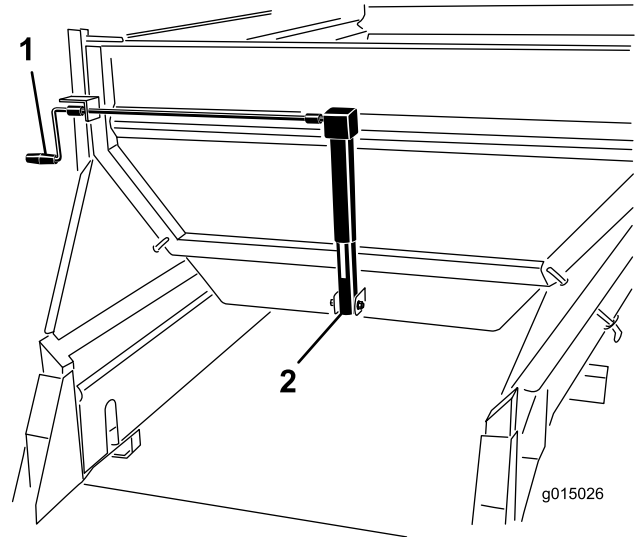

Figure 34

1. Crank
2. Gate jack

MH-400 EH models

Note: For this example we will select the **YELLOW** section.

Rotate the crank to adjust the gate until the arrow aligns with the center of the **YELLOW** section which is number 3 (Figure 34).

Using the wireless controller, set the floor belt speed percentage to match your desired speed pattern color.

Note: For this example we will set the option percent to **80 percent** matching the yellow color spread pattern previously selected.

Adjusting the Main Hopper Height

Using the hydraulic controls on the SH model or the wireless controller on the EH model, adjust the main hopper hydraulic cylinders until the arrow aligns with the **GREEN** section on the hydraulic cylinder decal (Figure 35).

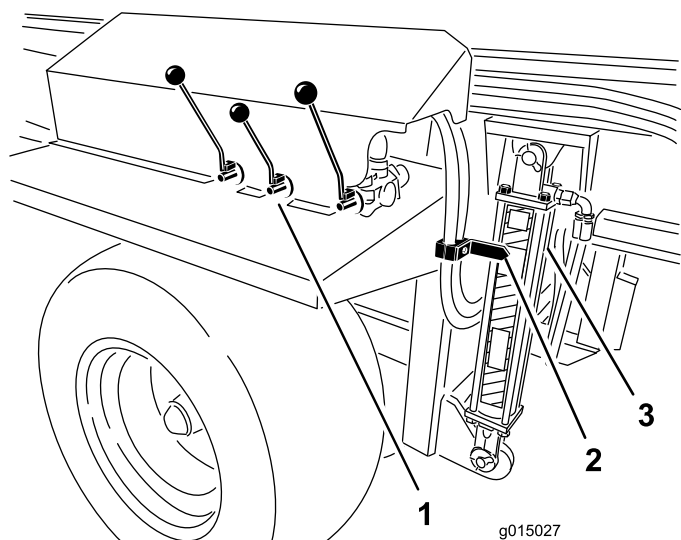

Figure 35

- | | |
|-----------------------|-------------|
| 1. Hydraulic controls | 3. Cylinder |
| 2. Arrow | |

Operate the Twin Spinner

1. Turn off the tow vehicle
2. On SH models, using the control levers, turn on the option and the conveyor belt (unload position).
3. For both the SH and EH models adjust the settings, spread pattern, and flow rate.

Note: You may have to experiment until you get the desired flow and spread depth. Other variables include ground speed and the type of material. Different materials vary in particle size, which can vary the spread pattern.

Always test new materials by spreading them in an open area away from people.

4. Start the tow vehicle and turn on the tow vehicle hydraulics.
5. On the SH model turn on the on/off pendant switch to start spreading. On the EH model turn on the option then the conveyor belt with the wireless controller.
6. On the SH model turn off the on/off pendant switch to stop spreading. The Twin Spinner will continue to operate. On the EH model turn off the conveyor belt and then the option.
7. For EH models the “all start” function can be used in place of the option start and belt start functions as a single operation start feature. The option will start first, then followed by the belt.
8. When the machine is empty, turn off the hydraulics before transporting the machine.

Note: When driving over uneven terrain, raise the machine to the maximum safe traveling range. This provides more ground clearance for the Twin Spinner.

▲ WARNING

Watch for people and other objects while spreading. The Twin Spinner can throw material at high speeds up to 40 feet (12 m).

Important: While traveling but not spreading, raise the machine to the maximum safe traveling distance, and turn off the Twin Spinner (Figure 35).

Fine Tuning the Twin Spinner

1. Verify that all the settings are correct.
2. If the spread pattern is not to the desired consistency, loosen the handles and slide the hopper in the desired direction to attain the desired spread pattern.

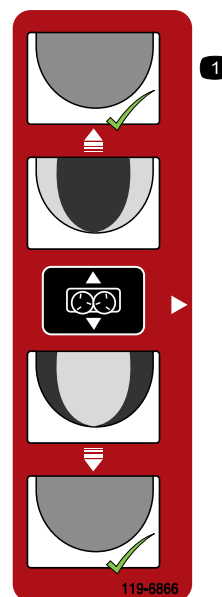

Figure 36

Cross Conveyor/Swivel Operation

Installing the Cross Conveyor/Swivel

The cross conveyor spreads material to either side of the MH-400 while the swivel kit allows the cross conveyor to swivel freely in a 270 degree arc, or to be locked into one of five fixed positions, 45 degrees apart.

Note: The MH-400 comes equipped with a pair of quick attach mounting clamps. Use these clamps to mount the cross conveyor/swivel to the MH-400.

1. Position the cross conveyor/swivel so the swivel kits two mounting brackets face toward the rear (away from the MH-400).

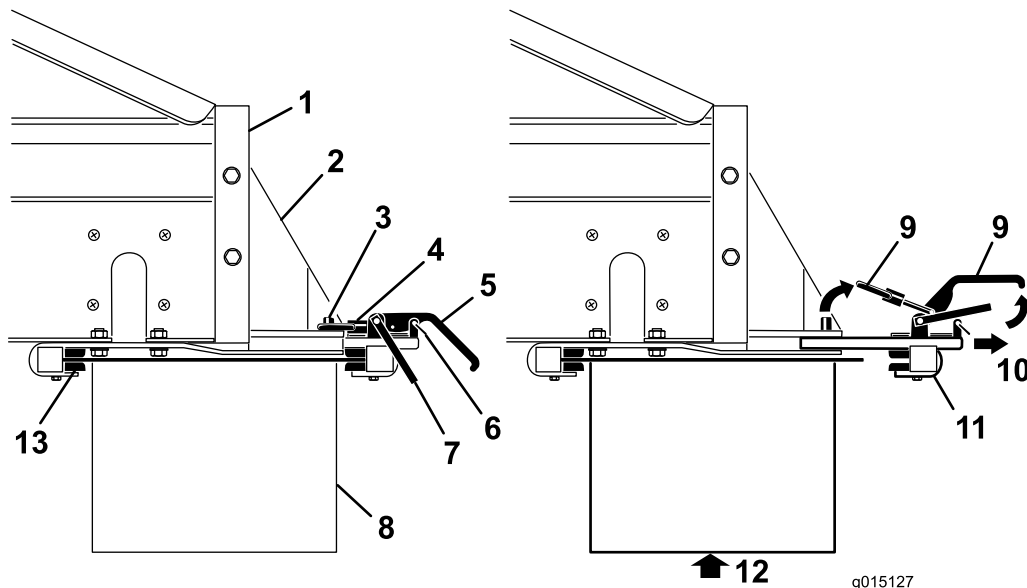

Figure 37

g015127

1. Rear of MH-400
2. Option attachment bracket
3. Lock pin
4. Lock ring
5. Clamp handle
6. Safety latch clip
7. Safety latch
8. Option
9. Lift
10. Pull
11. Rear clamp assembly
12. Support the option before removing the clamps
13. Front clamp brackets

6. With assistance, insert the front edge of the cross conveyor/swivel up and under the rear of the MH-400 into the front clamps on the brackets (Figure 37).
7. While supporting the cross conveyor/swivel, slide the rear option attachment clamp assembly back into the slots in the brackets, and over the rear edge (Figure 37).
8. Ensure that the cross conveyor/swivel is centered between the brackets. Then re-install the lock rings

over the lock pins and push down on the clamp handles.

Note: If the clamp assembly is too loose and the cross conveyor/swivel slides within the clamps, turn the lock rings into the clamps a few turns until the cross conveyor/swivel is secure.

Important: Do not over-tighten the clamps. This may bend the edges of the option.

9. Reinstall the safety latch clips to the clamp handles (Figure 37).

⚠ CAUTION

Ensure that you reinstall the safety latch clips into the clamps. Otherwise, the clamps may open during operation.

⚠ WARNING

The options are heavy. Use an assistant to help lift the cross conveyor/swivel.

Connecting the Hydraulic Hoses

⚠ WARNING

Ensure that the tow vehicle is turned off before making the hydraulic connections, to prevent the cross conveyor/swivel from accidentally turning on.

Ensure that the tow vehicle is turned off before making the hydraulic connections, to prevent the cross conveyor/swivel from accidentally turning on.

Connect the hydraulic hoses to the option control valve on the MH-400 as follows (Figure 38):

- Pull back (or push forward) on the outer sleeve of the female connector and insert the male connector.
- Hold the male connector firmly in place and release the outer sleeve of the female connector.
- Ensure that the connectors are pushed all the way in and are securely locked in place.
- With the tow vehicle hydraulics operating, pull back on the option control lever on the SH models or start the option using the option start button on the wireless controller on the EH models, and ensure that the cross conveyor/swivel is operating properly.

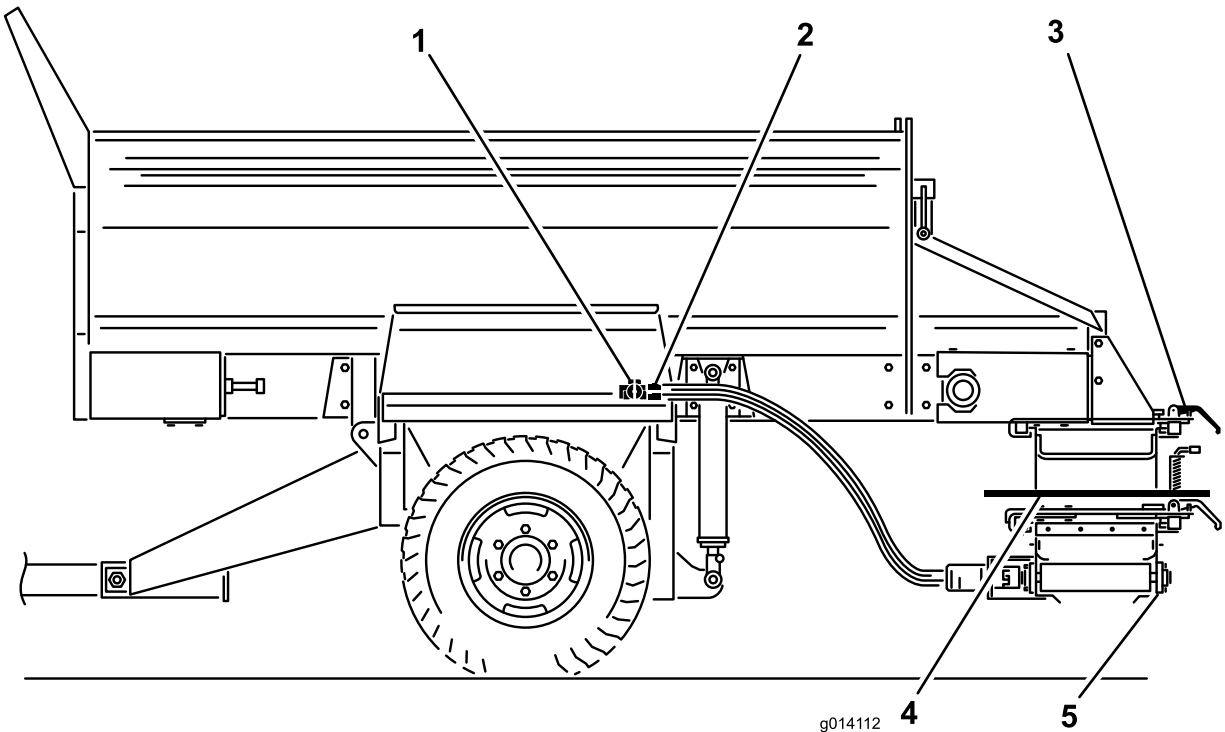

Figure 38

- | | |
|-------------------------|-------------------|
| 1. Option control valve | 4. Swivel kit |
| 2. Hose connections | 5. Cross conveyor |
| 3. Quick attach clamps | |

Operating the Cross Conveyor

Extending and Retracting the Cross Conveyor

Always operate the cross conveyor (Figure 39) separately from the main conveyor belt.

⚠ CAUTION

Always return the cross conveyor to the center position when traveling, otherwise the cross conveyor can hit people or objects, and can also be damaged.

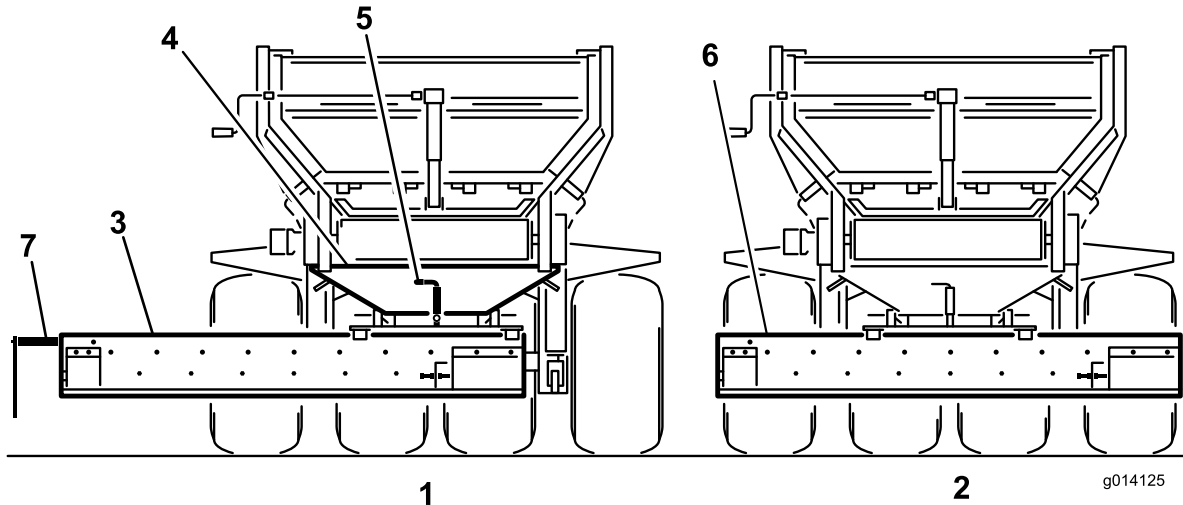

Figure 39

1. Extended position when conveying
2. Centered position when traveling
3. Cross conveyor
4. Swivel kit
5. Swivel lock pin
6. Remove or flip up the deflector
7. Material outlet (motor end)

Note: Always lower the hopper before adjusting the cross conveyor. Otherwise, the cross conveyor will rest at an angle.

Spreading Material from the Cross Conveyor

1. Turn off the tow vehicle.
2. On SH models using the control levers, turn on the option and the conveyor belt (unload position).
3. Open the adjustable section of the rear gate to allow for the desired flow rate. You may have to experiment until you get the desired flow and spread depth. Other variables include ground speed and the type of material
4. Turn on the tow vehicle hydraulics.
5. On EH models operate the option and the conveyor belt with the wireless remote.

1. Remove the safety pins from both option attachment clamps on the swivel kit.
2. Loosen the option attachment clamp brackets
3. Slide the conveyor to the center or side.
4. Re-tighten the clamp brackets.
5. Re-install the safety pins.
6. On SH models adjust the speed of the cross conveyor with the hydraulic lever on the right. On EH models adjust the speed of the cross conveyor with the wireless remote.

6. On SH models turn off the tow vehicle hydraulics to stop material movement, or turn off the on/off pendant switch.

Note: For SH models the on/off pendant switch stops the machine conveyor belt, not the cross conveyor.

7. When finishing using the cross conveyor, always return it to the center position.

Operating the Swivel Kit

To direct the flow of material from the cross conveyor in any direction, pull up the spring-loaded locking pin on the swivel kit into the unlock or open position. This allows you to manually move the cross conveyor freely from side to side on the swivel bearing (Figure 39).

To keep the cross conveyor in a fixed position, release the spring-loaded locking pin into one of the five locking positions on the swivel kit.

Note: When traveling over uneven terrain, raise the machine to the maximum safe traveling range. This provides more ground clearance for the cross conveyor/swivel.

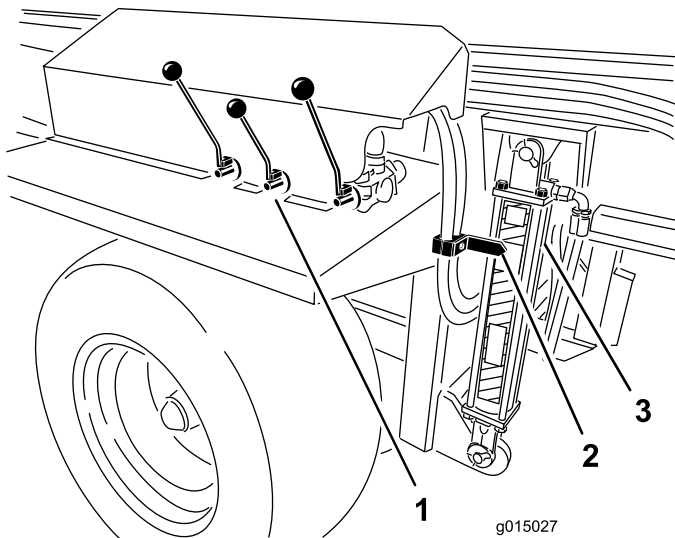

Figure 40

- 1. 1. Hydraulic controls
- 2. Arrow
- 3. Cylinder

Maintenance

Premaintenance Procedures

⚠ WARNING

Disconnect all power sources to the machine before doing maintenance work.

⚠ WARNING

Install the hydraulic cylinder supports before doing any maintenance work under the hopper (Figure 41).

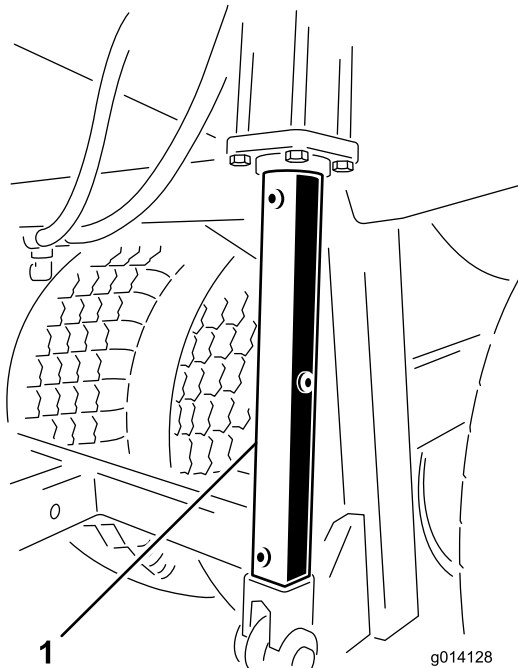

Figure 41

1. Hydraulic cylinder support

2. Pump grease into the bearing or bushing.
3. Wipe up excess grease.

The bearing and bushing lubrication points are as follows:

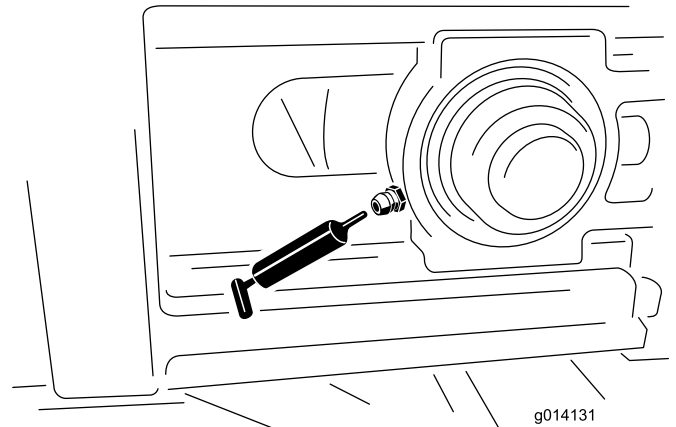

Figure 42

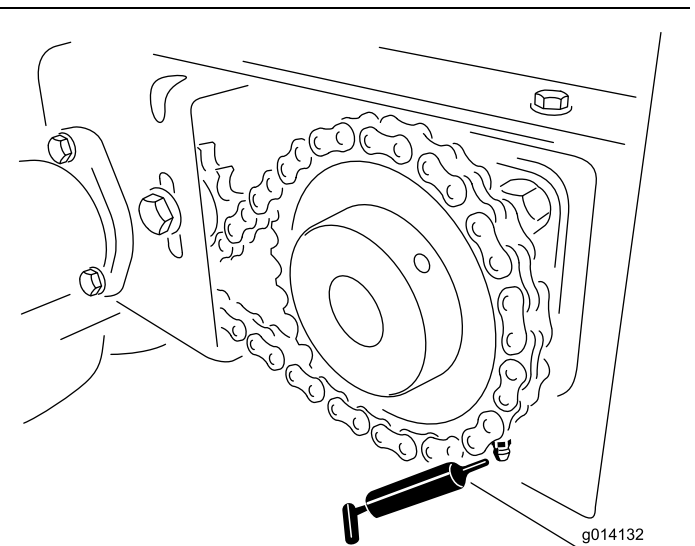

Figure 43

Lubrication

The machine has grease fittings that must be lubricated regularly with No. 2 General Purpose Lithium Base Grease. If machine is operated under normal conditions, lubricate all bearings and bushings after every 50 hours of operation. Bearings and bushings must be lubricated daily when operating conditions are extremely dusty and dirty. Dusty and dirty operating conditions could cause dirt to get into the bearings and bushings, resulting in accelerated wear. Lubricate grease fitting immediately after every washing, regardless of interval specified.

1. Wipe grease fitting clean so foreign matter cannot be forced into the bearing or bushing.

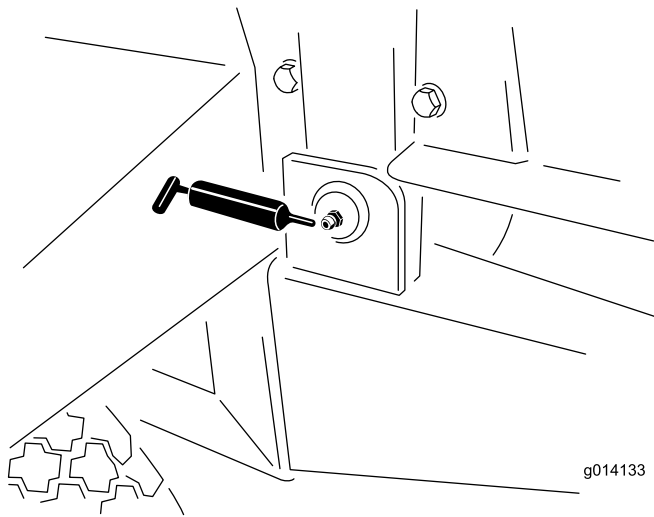

Figure 44

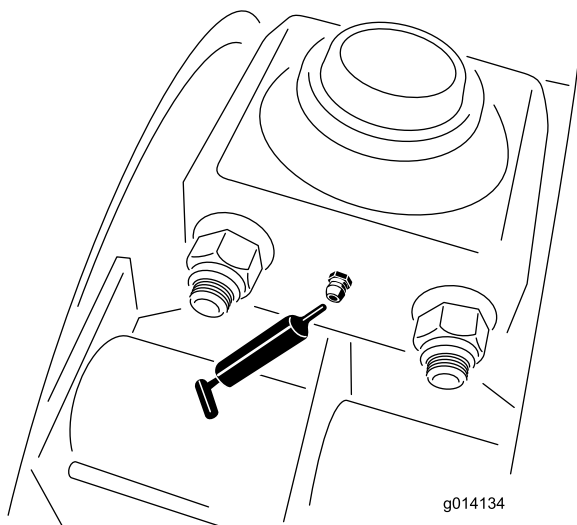

Figure 45

Safety Checks

At the start of each day, complete these safety checks before operating the machine. Report any safety problems to your supervisor. See the Safety Instructions in this manual for details.

Note: Photocopy these pages and use them as a regular safety checklist

Tires and Wheels

- The recommended tire pressure is 25 psi (172 kPa), or as recommended by the tire manufacturer.
- Check for excessive wear or visible damage.
- Check that the wheel bolts are tight and none are missing.

Rear Gate

- Check that the rear gate closes and latches securely.
- Check that the adjustable section of the rear gate opens and closes without sticking.

Hitch, Jack, and Rear Jack Leg

- Check that the hitch pin and jacks are not damaged, and the safety pins are in place. (Replace missing or damaged safety pins.)
- Check that the hitch connections are not loose. (If so, install a spacer between the hitch connections.)
- Safely stow all jacks in the up position before traveling.

Hydraulic System

- Check the hydraulic system for oil leaks. If you find a leak, tighten the fitting, or replace or repair the damaged part.
- Check the hydraulic hoses for wear or visible damage.
- Check the hydraulic oil level. Fill up if necessary.

Conveyor Belt and Rollers

- Once a week, check that the conveyor belt is tracking straight on the rollers and does not slip. Make adjustments if required.
- Every four months, check that the idler rollers between the front and rear rollers are not bent or seized. Replace or repair if required.

Belt and Rear Gate Seals

Check all rubber seals for wear or damage. Replace or repair the seals if any leakage occurs.

Options

- Check that the quick attach brackets are securely locked into place and that the safety clips are installed. Replace missing safety clips.
- Check that the option is securely clamped and does not move or slide out. Adjust clamps if required.
- Check the paddles on the Twin Spinner disks for wear. Replace them when they wear thin.
- Check the Twin Spinner housing for signs of cracking or corrosion.

Safety Decals

Check that the safety decals are undamaged and legible, otherwise replace them.

Electric Brakes

- Once a month, conduct a simple visual inspection of your brake shoes and linings.
- Inspect and service your electric brakes once a year.

Hydraulic System

The machine is shipped from the factory filled with high quality hydraulic fluid. Check the level of hydraulic oil before the machine is first started and daily thereafter. The recommended replacement oil is as follows:

Toro Premium Transmission/Hydraulic Tractor Fluid
(Available in 5 gallon pails or 55 gallon drums. See parts catalog or Toro distributor for part numbers.)

Alternate fluids: If the Toro fluid is not available, other petroleum-based Universal Tractor Hydraulic Fluids (UTHF) may be used provided its specifications fall within the listed range for all the following material properties and it meets industry standards. We do not recommend the use of synthetic fluid. Consult with your lubricant distributor to identify a satisfactory product.

Note: Toro will not assume responsibility for damage caused by improper substitutions, so use only products from reputable manufacturers who will stand behind their recommendation.

Material Properties:

Viscosity, ASTM D445	cSt @ 40°C 55 to 62
Viscosity Index ASTM D2270	140 to 152

cSt @ 100°C 9.1 to 9.8

Pour Point, ASTM D97 -35°F to -46°F

Industry Specifications:

API GL-4, AGCO Powerfluid 821 XL, Ford New Holland FNHA-2-C-201.00, Kubota UDT, John Deere J20C, Vickers 35VQ25, and Volvo WB-101/BM

Changing Tires

Changing an Outside Tire

1. Keep the machine attached to the tow vehicle, remove any options, and apply the emergency brake.
2. Remove all material from the hopper.
3. Block the tires on the opposite side of the flat tire.
4. Loosen the six wheel bolts on the flat tire with a lug wrench, but do not remove them.
5. Hoist or jack the machine until the tire is off the floor or ground. Ensure that the machine is stable.
6. Remove the loose wheel bolts and remove the tire.

7. Repair the damaged tire.
8. Re install the tire onto the machine by reversing the above steps.

Note: Ensure that the wheel is centered on the hub and all six wheel bolts are tight. Torque in a crossover pattern to 100 ft-lb (13.8 kg-m).

Changing an Inside Tire

1. Keep the machine attached to the tow vehicle, remove any options, and apply the emergency brake.
2. Remove all material from the hopper.
3. Block the tires on the opposite side of the flat tire.
4. On the side with the tire to be changed, remove the four 5/8 inch bolts holding the walking beam suspension's bearings to the chassis. (Loosen but do not remove the outside wheel nuts to give more clearance for bearing bolts).
5. Hoist or jack the machine until the inside tire and walking beam axle assembly can be rolled out from underneath. Ensure that the machine is stable.
6. Remove the tire.
7. Repair the damaged tire.
8. Re install the tire onto the machine by reversing the above steps.

Note: Ensure that the wheel is centered on the hub and all six wheel bolts and the bearing bolts are tight to 100 ft-lb (13.8 kg-m).

Tracking the Conveyor Belt

If the conveyor belt is not centered and tracks to one side, it needs to be adjusted (Figure 46). The best time to do this is between loads during operation.

1. Go to the rear of the machine and determine which side of the belt is touching.
2. Go to the front on the same side, loosen the locking nut, and tighten the adjuster nut by one quarter turn.
3. Tighten both locking nuts before running the machine.
4. Load the machine with material and run the load through until empty. Repeat multiple times.
5. Stop the belt and go to the rear of the machine to observe the results.

You may need to repeat the above steps several times until the belt begins to move and track properly.

Note: The belt may move slightly depending on the type of load and its position. If the belt is not touching the side rails, you do not need to track the belt.

Important: Do not adjust the belt's rear drive roller. It is set to factory specifications. Contact your authorized Toro distributor if adjustment is required.

▲ WARNING

Use extreme caution around moving parts with safety guards removed.

- Turn on the conveyor belt.
- If belt slips, tighten the tension bolts evenly (with machine off) half a turn and recheck. Continue until the belt moves without any slippage.
- Give both tensioning bolts another half turn. At this point you should have proper tension.
- To verify, look underneath at the chassis cross member. The middle of the belt should just clear the chassis cross member when the MH-400 is in the down position. If the middle of the belt is touching the cross member, tighten both tensioning bolts another quarter of a turn.

Important: Be patient! Do not over-tension the belt.

Important: Do not use air tools on the belt tensioning bolts.

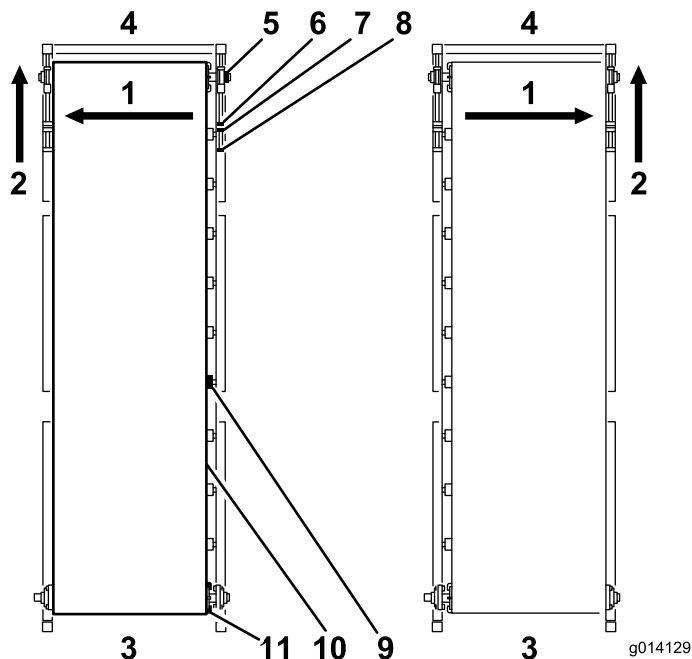

Figure 46

- | | |
|--|--------------------|
| 1. If belt is tracking toward this side... | 7. Locking nut |
| 2. Then adjust this tensioner to the front on the same side. | 8. Tensioner rod |
| 3. Rear | 9. Belt roller |
| 4. Front | 10. Conveyor belt |
| 5. Take up bearing | 11. Drive roller~" |
| 6. Adjuster nut | |

Tensioning the Conveyor Belt

Check and adjust the belt tension frequently (Figure 46). All rubber conveyor belts will stretch, especially when they are new or have not been used for awhile.

- Park the MH-400 on level ground with the rear gate and feed gate at least 1/4 inch (6.25 mm) off the floor (depending on the material).
- Fully load the machine with sand that you expect the MH-400 to use.
- Remove the black front covers on either side of the MH-400.
- Using two wrenches, hold the end of the tensioner rod stationary, while loosening the locking nut closest to the end of the rod.
- Move the locking nut back 1–2 inches (2–5 cm).

Changing the Conveyor Belt

Read these instructions before removing the belt. If the belt is completely destroyed, simply use a knife to cut the belt in an undamaged area. If you intend to make a warranty claim, the belt supplier must inspect the belt to evaluate the damage and make recommendations for replacement.

Removing the Belt

- Remove the black safety covers located on the four outer corners of the machine.
 - Remove the guides for the inner rubber liner from the front and both sides of the hopper, with the metal rails attached.
 - Remove the silicone sealer on the rear of the metal rails (but remember to re apply the silicone sealer when re installing them).
 - At both front corners, use two wrenches to hold the end of the tensioner rod stationary.
 - Loosen the nut closest to the end of the tensioning rod.
 - Move the inside adjusting nut back until the tensioning rod clears the pillow block bearing.
- Note:** The front idler roller is supported by two pillow block bearings sitting in an upper and lower guide (one set on each side of the machine).
- Support the front idler roller.

8. Go to the right front corner and remove the locking collar that holds the pillow block bearing on the shaft. Do this by backing off the set screws and turning the locking collar counterclockwise. Using a hammer and punch, tap the locking collar counterclockwise until it releases from the shaft.
9. Repeat this step for the left front corner.
10. Remove the pillow block bearings by sliding the idler roller back so the pillow block bearings slide out of their guides.
11. Remove the two safety brackets and slide the roller down through the open hole.
12. Go to the rear of the machine and loosen the tensioning sprocket.
13. Remove the chain from the drive sprocket.
14. Loosen the set screws on the drive sprocket and remove the drive sprocket and key from the drive roller shaft.
15. Support the rear drive roller.

Important: Do not disturb the rear roller adjustment bracket assembly. It is designed to adjust the rear roller automatically if the belt is not tracking accurately

16. Remove the four bolts in the flange bearings on both sides.
17. Remove the locking collars next to the flange bearings on the shaft, and slide both bearings off the shaft.
18. Remove the two option attachment brackets (Figure 47).

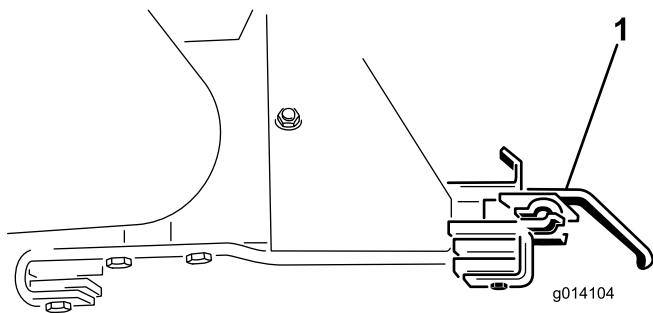

Figure 47

1. Option attachment bracket

19. Lower the drive roller down through the slots.
20. Remove the rear gate for a better view.
21. Note the position of the cartridge inside the hopper, so that you can re install it in the same position and direction. It is bolted in six places along the side of the machine (three 4 bolt plates on each side).

22. Secure the cartridge by using straps from a lifting device on each of the four corners.
23. Remove the (24) bolts to release the cartridge (Figure 48).

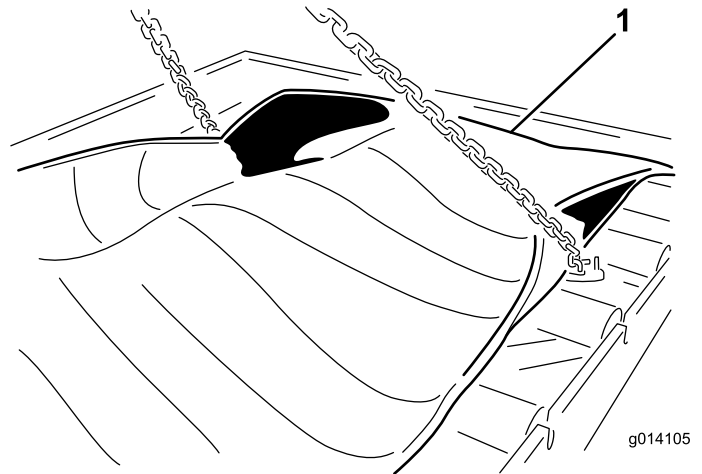

Figure 48

1. Secure and remove the belt cartridge

24. Remove the cartridge by lifting it out from the top of the machine. Place it on the ground (Figure 49).

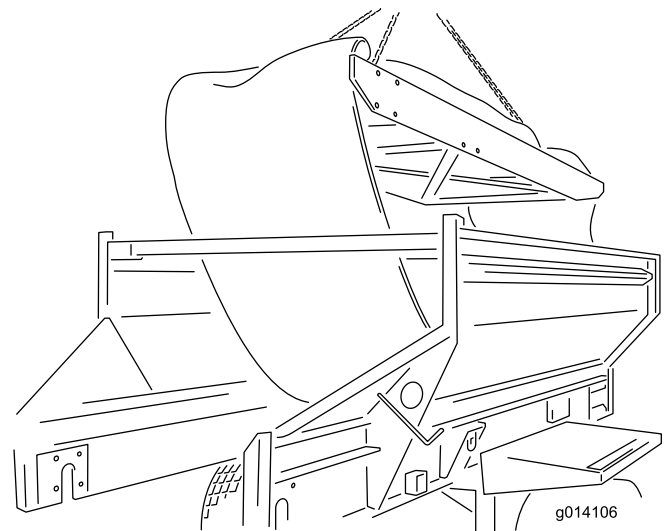

Figure 49

Installing the Belt

To install a new belt, reverse the above instructions, but keep in mind the following important notes and instructions.

Important: The conveyor belt is designed to work primarily in one direction. Ensure that the painted arrow in the middle of the belt is pointing towards the rear of the machine (looking down from above).

Note: Before sliding the rear drive roller back up through the slot and into place, ensure that you have already installed the four bolts (from the inside facing out) for connecting the pillow block bearings. Otherwise, you will have to remove the drive roller to gain enough clearance to install these bolts.

When installing the rear drive roller, ensure that the shaft connecting to the motor is on the left side. It has a keyhole cut into it for securing the drive sprocket.

Before applying tension with the tensioner rods at the front of the machine, use your hands to manually center the belt at the front and rear.

Track and tension the belt by following the instructions in the Maintenance Section of the manual.

The front idler and rear drive rollers provide excellent traction for pulling the belt under load, so do not overtighten or stretch the belt.

Apply silicone sealer to the rear side of the metal rails and at the two front corners of the floor where the rails meet. The sealer deflects any material from getting past the rails.

Adjusting the Conveyor Drive Chain

If the conveyor drive chain is loose, it needs to be tightened (Figure 50).

1. Turn off the tow vehicle and set the parking brake.
2. Remove the rear conveyor drive guard.
3. Loosen the bolt that goes through the tensioner sprocket.
4. Tighten the positive locking screw using moderate force.
5. Tighten the tensioner sprocket bolt.
6. Check that the chain is sufficiently lubricated and the sprockets are secure to the shafts.
7. Replace the rear conveyor drive guard.

⚠ CAUTION

Do not over tension the chain. Leave just enough tension to take up the extra slack.

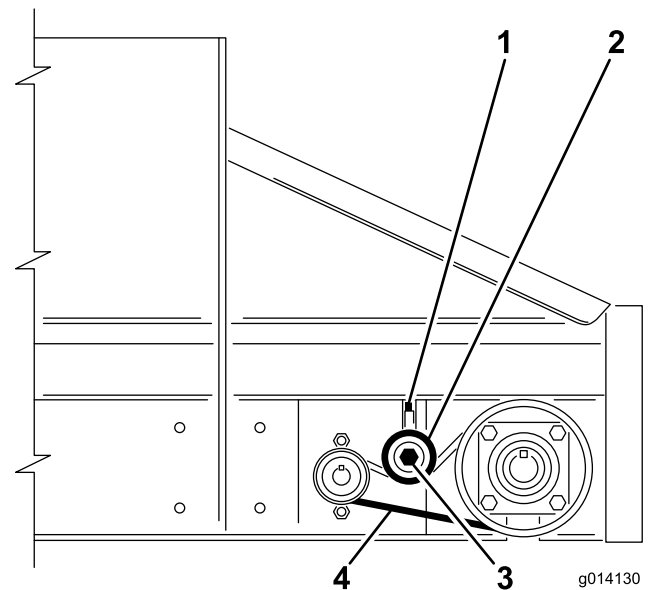

Figure 50

- | | |
|--|---|
| 1. Positive locking screw | 3. Sprocket bolt |
| 2. Tensioner sprocket—push down to tighten, do not | 4. Slack side, about 1/4 inch (6.25 mm) movement over tension |

Maintaining the Electric Brakes

Inspecting the Electric Brakes

Once a month, conduct a simple visual inspection of your brake shoes and linings.

Inspect and service your electric brakes once a year.

Adjusting the Electric Brakes

Adjust the electric brakes after the first three months of operation, or sooner depending on use or performance.

1. Jack up the machine securely.
2. Ensure that the wheel and drum rotate freely.
3. Remove the adjusting hole cover from the slot on the bottom of the brake backing plate.
4. With a screwdriver, rotate the star wheel of the adjuster assembly to expand the brake shoes (Figure 51).

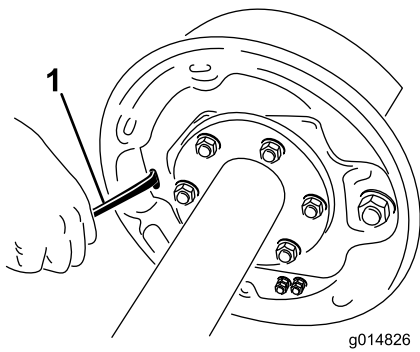

Figure 51

1. Screwdriver

5. Adjust the brake shoes out until the pressure of the linings against the drum makes the wheel difficult to turn.
6. Rotate the star wheel in the opposite direction until the wheel turns freely with a slight drag on the lining.
7. Replace the adjusting hole cover.
8. Repeat the above procedure on each brake.

Inspecting the Brake Shoes and Linings

Once a month, conduct a simple visual inspection of your brake shoes and linings.

When a brake shoe becomes worn, replace both shoes on each brake, and both brakes on the same axle. This ensures that the brakes remain balanced.

Replace the brake linings when they are

- worn to 1/16 inch (1.6 mm) or less remaining thickness
- contaminated with grease or oil
- abnormally scored or gouged

Note: Hairline heat cracks are normal in the brake linings and should not cause concern.

Yearly Brake Cleaning and Inspection

Inspect and service your electric brakes once a year or more often with heavy use or declining performance

- Change magnets and shoes when they become worn or scored.
- Clean the backing plate, magnet arm, magnet, and brake shoes with an automotive brake cleaner.

- Ensure that all parts removed are replaced in the same brake and drum assembly that they were removed from.
- Inspect the magnet arm for any loose or worn parts.
- Check the shoe return springs, the hold down springs, and the adjuster springs for stretch or deformation and replace them if required.

CAUTION

Brake dust can be hazardous to your health if inhaled, take precautions when servicing brakes:

- Do not create or breathe dust.
- Do not machine, file, or grind the brake linings.
- Do not use compressed air or dry brushing for cleaning.

Brake Lubrication

Before reassembling the electric brakes, apply a light film of anti seize compound, or grease such as “Lubriplate,” on the:

- brake anchor pin
- actuating arm bushing and pin
- areas on the backing plate that are in contact with the brake shoes and magnet lever arm
- actuating block on the actuating arm

Important: Do not allow grease to contact the brake linings, drums, or magnets.

Inspecting the Magnets

The brakes’ electromagnets are designed to provide the proper input force and friction.

Inspect the magnets regularly, and replace if they become unevenly worn. Use a tool with a straight edge to check wear.

Even if the wear is normal, you should replace the magnets if any part of the magnet coil is visible through the friction material on the magnet face. Replace the magnets in pairs (both sides of an axle).

When replacing the magnets, also resurface the drum armature surface.

Storage

Before storing the machine for the season:

1. Thoroughly clean the machine. Remove parts if necessary.
2. Remove the wireless controller. Also, remove the batteries from the controller.
3. Check all fasteners and tighten, if necessary.
4. Grease all fittings and pivot points. Wipe off any excess lubricant.
5. Lightly sand any painted areas that are scratched, chipped, or rusted, and apply touch up paint.
6. Store the machine indoors, if possible.

Troubleshooting

Base Unit Troubleshooting Hints	
Indications	
Power LED not active	<ul style="list-style-type: none"> • +12 to +14.4 VDC input power present? • Check input power polarity.
Power LED Red or Green	Indicates an internal component failure.
TX/RX not active	<ul style="list-style-type: none"> • Check for obstructions preventing line of sight transmission. • Check that the handheld remote is active. • Re associate the handheld remote to the base unit.
Health LED blinking Amber	Indicates an internal problem.
Health LED blinking Red	Over temperature indicated.
Out LED not active	<ul style="list-style-type: none"> • Check that the handheld LEDs are active when the buttons are pushed. • Are output buttons being simultaneously pressed? • LCD indicates error conditions when applicable.
Out LED Amber	<ul style="list-style-type: none"> • Over temperature channel indication. • Over current channel indication. • Active channel current consumption less than 1A typical. (This is not a problem in cases where less than 1A draw is a normal condition.) • Check the outputs for loose wiring, etc.
Out LED quickly pulsing Orange	Indicates an over current condition.
Out LED slowly pulsing Amber	Over temperature indication.

Handheld Display Message Summary	
Displayed Message	
ASSOC PENDING	Association yet to be made.
ASSOC ACTIVE	Association attempt in progress.
CLR CHAN SCAN	Scan to find a clear channel.
POW UP BUNIT	Power up the Base Unit.
ASSOC SUCCESS	Association attempt was successful.
ALL STORE	Store all current set values in current working memory.
OPTION STORE	Store the current Option settings in current working memory.
FLOOR STORE	Store the current Floor settings in current working memory.
PRESET 1 STORE	Store the current Preset 1 setting in current working memory.
PRESET 2 STORE	Store the current Preset 2 setting in current working memory.
PRESET 3 STORE	Store the current Preset 3 setting in current working memory.
FLR REV STORE	Store the current Floor Reverse setting in current working memory.
WAITING FOR BASE	Remote is waiting for a Base Unit response.
HOPPER RAISE	Remote is sending Hopper Raise command.
HOPPER LOWER	Remote is sending Hopper Lower command.
COMMAND POW DOWN	Operator has pressed the ON/OFF button to power down.
LOW BAT POW DOWN	Cyclic warning that the batteries are low and need to be changed.
INACTIV POW DOWN	Auto shutdown after 30 minutes of button inactivity.
PP180	Product to which the system is set to control.
MH400	Product to which the system is set to control.
SOFTWARE VER XX	SmaRT System software version.

BAT XX% BUMPS XX	Remaining battery life in percentage. Number of Base Unit Messages Per Second being received.
CHANNEL X	Channel in GHz currently being used by the SmaRT system.
HHELD ID XXXXXX	Identity of the Handheld Remote in hexadecimal.
BUINT ID XXXXXX	Identity of the Base Unit in hexadecimal.
MODEL PP180	Model of the PP180.
MODEL MH400	Model of the MH400.
FLR XX% OPT XX%	The current Floor speed in percent. The current Option speed in percent.
FLRS XX% OPTS XX%	Display of the stored regular Floor speed and Option speed with 0% command to the output allowing the operator to decide to use the current setting or change it.
SW STUCK XXXXXXXX	Switch is stuck. Identity of the stuck switch.

Schematics

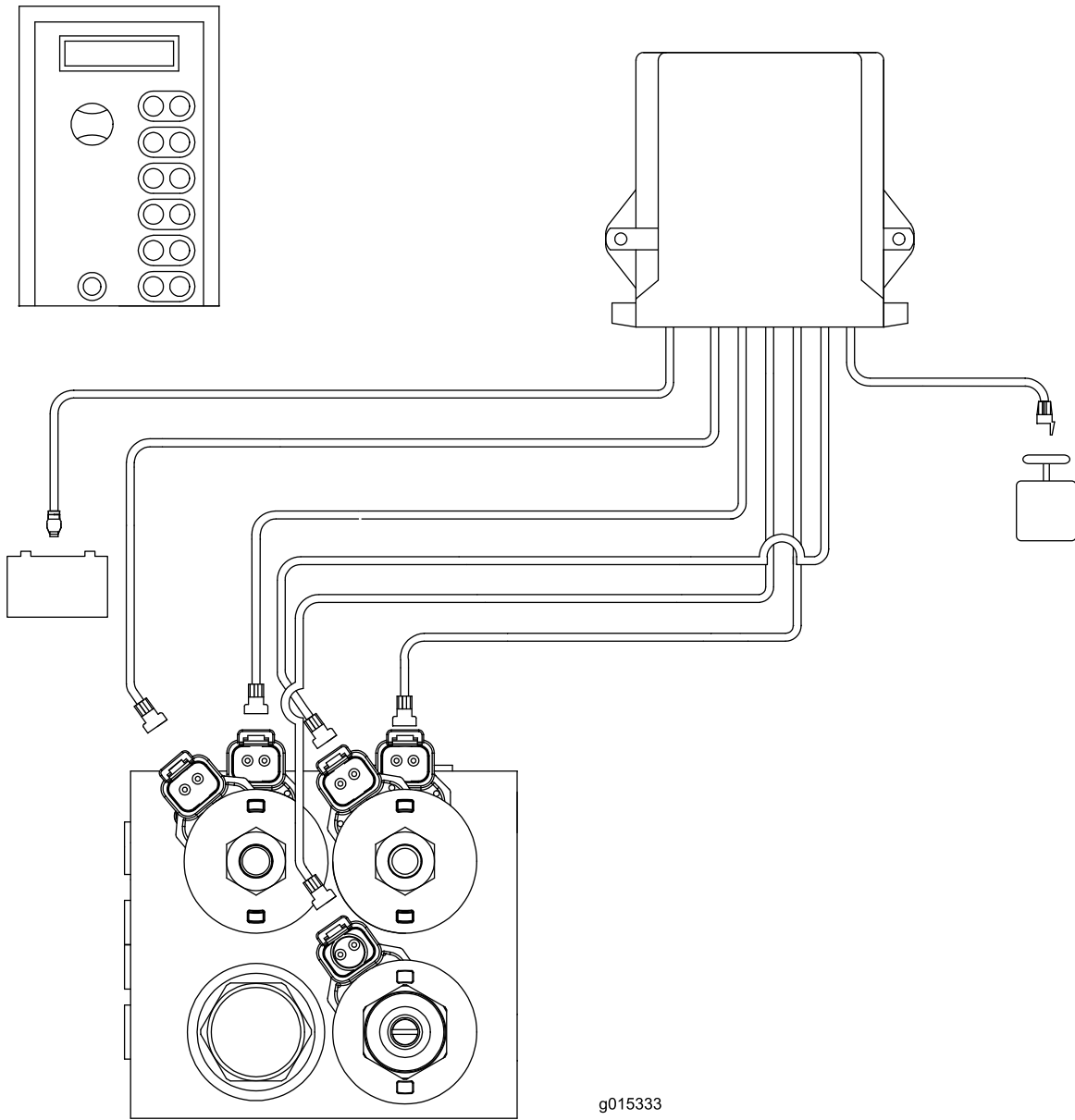

g015333

Electrical Schematic - EH Models (Rev. -)

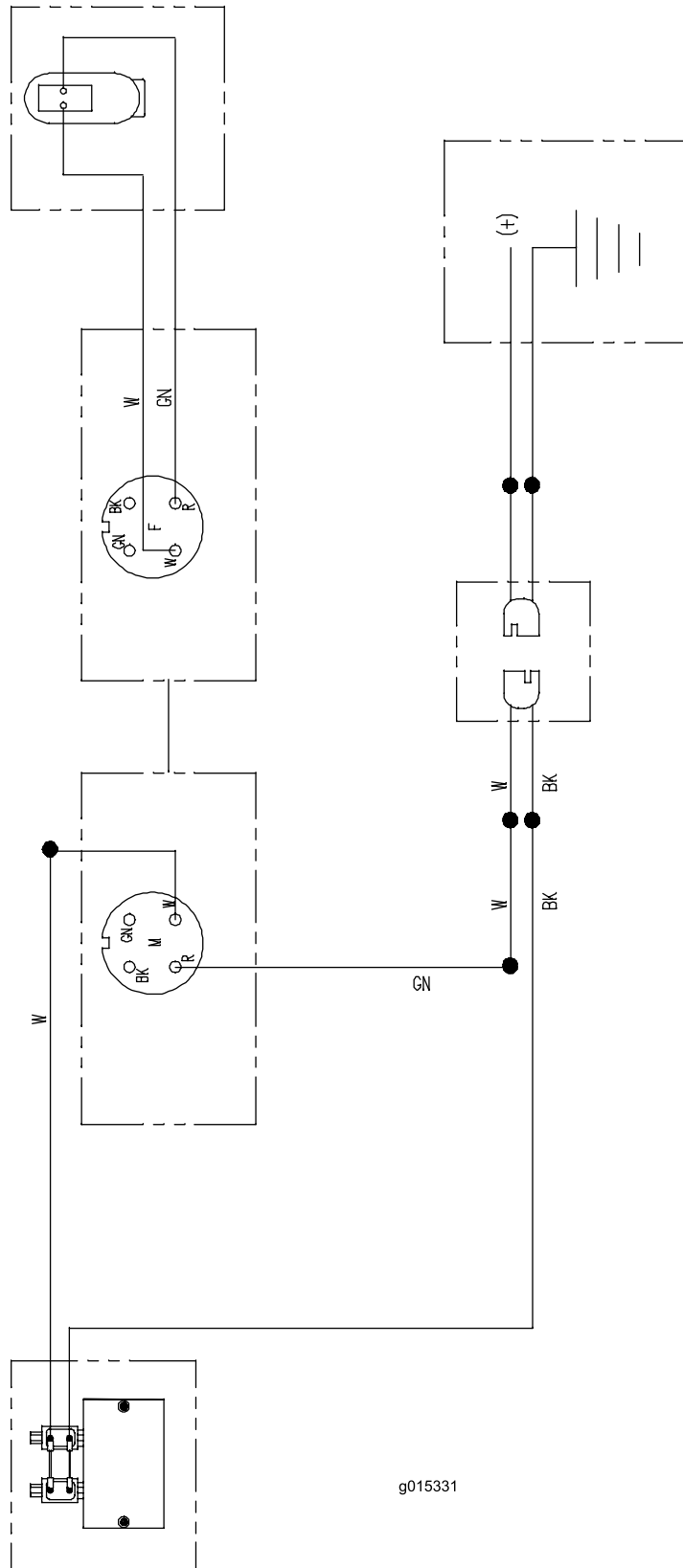

Electrical Schematic - SH Models (Rev. -)

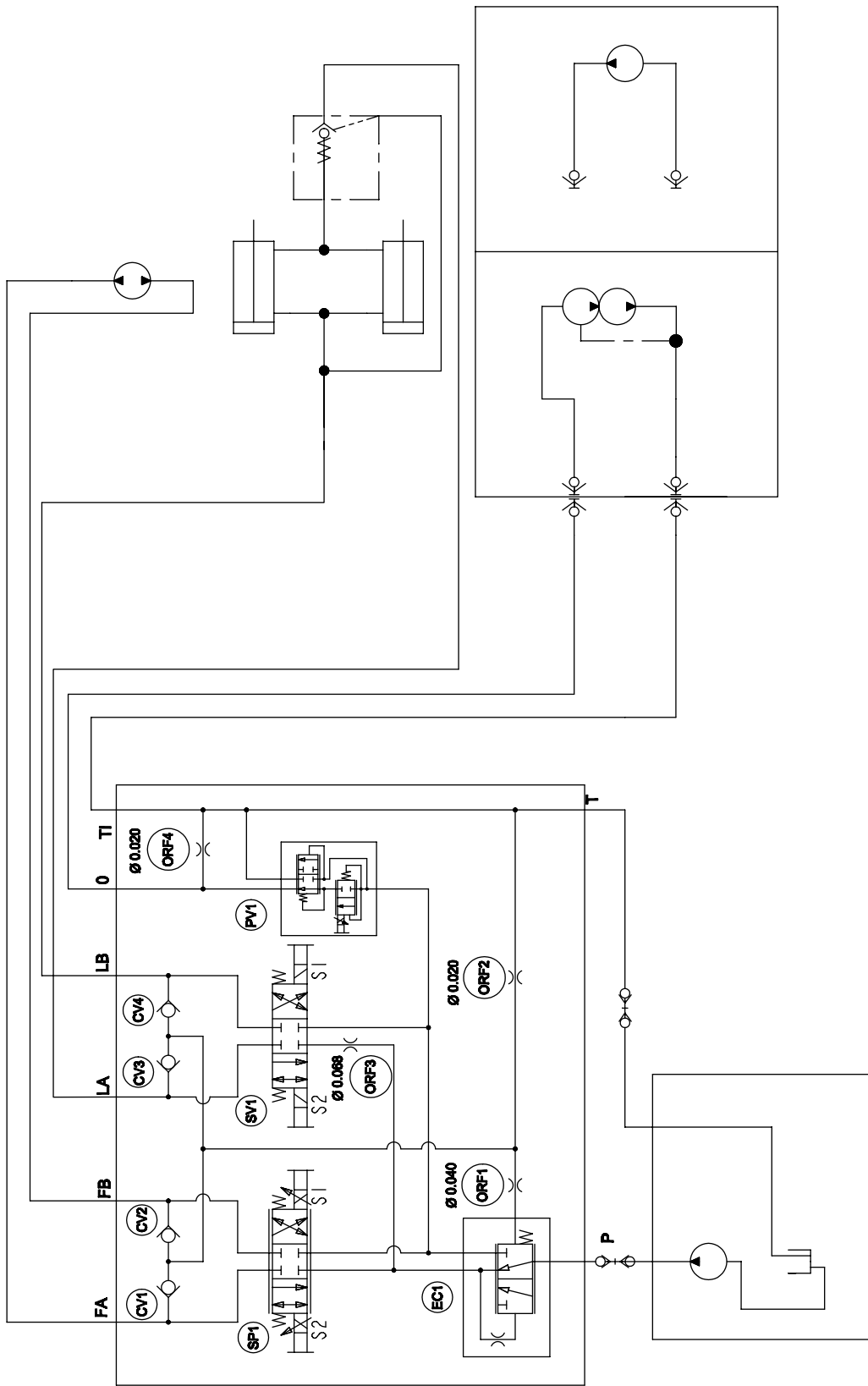

Hydraulic Schematic - EH Models (Rev. -)

g015334

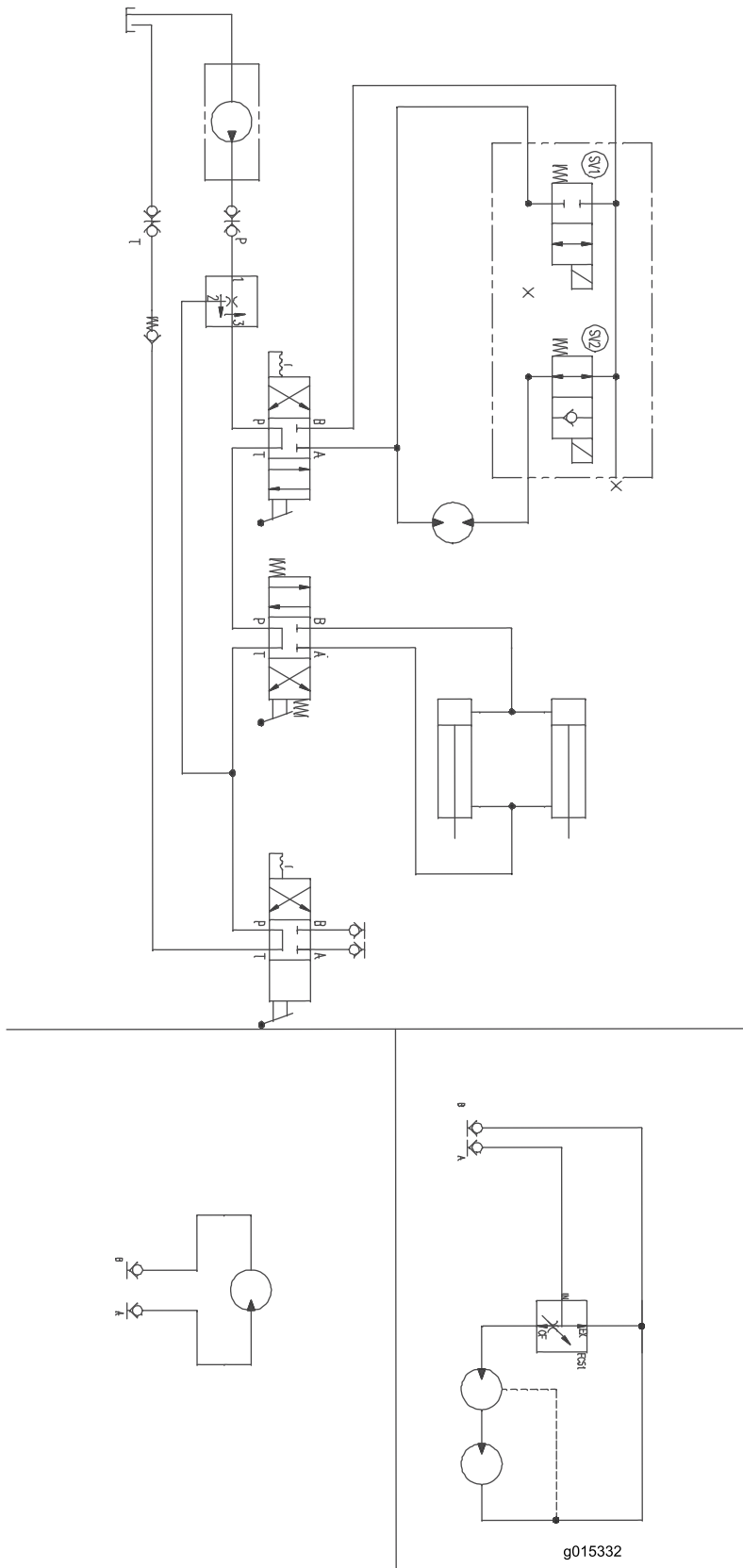

Hydraulic Schematic - SH Models (Rev. -)

Notes:

Notes:



The Toro Total Coverage Guarantee

A Limited Warranty

Conditions and Products Covered

The Toro Company and its affiliate, Toro Warranty Company, pursuant to an agreement between them, jointly warrant your Toro Commercial product ("Product") to be free from defects in materials or workmanship for two years or 1500 operational hours*, whichever occurs first. This warranty is applicable to all products with the exception of Aerators (refer to separate warranty statements for these products). Where a warrantable condition exists, we will repair the Product at no cost to you including diagnostics, labor, parts, and transportation. This warranty begins on the date the Product is delivered to the original retail purchaser.

* Product equipped with an hour meter.

Instructions for Obtaining Warranty Service

You are responsible for notifying the Commercial Products Distributor or Authorized Commercial Products Dealer from whom you purchased the Product as soon as you believe a warrantable condition exists. If you need help locating a Commercial Products Distributor or Authorized Dealer, or if you have questions regarding your warranty rights or responsibilities, you may contact us at:

Toro Commercial Products Service Department
Toro Warranty Company
8111 Lyndale Avenue South
Bloomington, MN 55420-1196
952-888-8801 or 800-952-2740
E-mail: commercial.warranty@toro.com

Owner Responsibilities

As the Product owner, you are responsible for required maintenance and adjustments stated in your *Operator's Manual*. Failure to perform required maintenance and adjustments can be grounds for disallowing a warranty claim.

Items and Conditions Not Covered

Not all product failures or malfunctions that occur during the warranty period are defects in materials or workmanship. This warranty does not cover the following:

- Product failures which result from the use of non-Toro replacement parts, or from installation and use of add-on, or modified non-Toro branded accessories and products. A separate warranty may be provided by the manufacturer of these items.
- Product failures which result from failure to perform recommended maintenance and/or adjustments. Failure to properly maintain your Toro product per the Recommended Maintenance listed in the *Operator's Manual* can result in claims for warranty being denied.
- Product failures which result from operating the Product in an abusive, negligent, or reckless manner.
- Parts subject to consumption through use unless found to be defective. Examples of parts which are consumed, or used up, during normal Product operation include, but are not limited to, brake pads and linings, clutch linings, blades, reels, rollers and bearings (sealed or greasable), bed knives, spark plugs, castor wheels and bearings, tires, filters, belts, and certain sprayer components such as diaphragms, nozzles, and check valves, etc.
- Failures caused by outside influence. Conditions considered to be outside influence include, but are not limited to, weather, storage practices, contamination, use of unapproved fuels, coolants, lubricants, additives, fertilizers, water, or chemicals, etc.
- Failure or performance issues due to the use of fuels (e.g. gasoline, diesel, or biodiesel) that do not conform to their respective industry standards.

Countries Other than the United States or Canada

Customers who have purchased Toro products exported from the United States or Canada should contact their Toro Distributor (Dealer) to obtain guarantee policies for your country, province, or state. If for any reason you are dissatisfied with your Distributor's service or have difficulty obtaining guarantee information, contact the Toro importer.

- Normal noise, vibration, wear and tear, and deterioration.
- Normal "wear and tear" includes, but is not limited to, damage to seats due to wear or abrasion, worn painted surfaces, scratched decals or windows, etc.

Parts

Parts scheduled for replacement as required maintenance are warranted for the period of time up to the scheduled replacement time for that part. Parts replaced under this warranty are covered for the duration of the original product warranty and become the property of Toro. Toro will make the final decision whether to repair any existing part or assembly or replace it. Toro may use remanufactured parts for warranty repairs.

Deep Cycle and Lithium-Ion Battery Warranty:

Deep cycle and Lithium-Ion batteries have a specified total number of kilowatt-hours they can deliver during their lifetime. Operating, recharging, and maintenance techniques can extend or reduce total battery life. As the batteries in this product are consumed, the amount of useful work between charging intervals will slowly decrease until the battery is completely worn out. Replacement of worn out batteries, due to normal consumption, is the responsibility of the product owner. Battery replacement may be required during the normal product warranty period at owner's expense. Note: (Lithium-Ion battery only): A Lithium-Ion battery has a part only prorated warranty beginning year 3 through year 5 based on the time in service and kilowatt hours used. Refer to the *Operator's Manual* for additional information.

Maintenance is at Owner's Expense

Engine tune-up, lubrication, cleaning and polishing, replacement of filters, coolant, and completing recommended maintenance are some of the normal services Toro products require that are at the owner's expense.

General Conditions

Repair by an Authorized Toro Distributor or Dealer is your sole remedy under this warranty.

Neither The Toro Company nor Toro Warranty Company is liable for indirect, incidental or consequential damages in connection with the use of the Toro Products covered by this warranty, including any cost or expense of providing substitute equipment or service during reasonable periods of malfunction or non-use pending completion of repairs under this warranty. Except for the Emissions warranty referenced below, if applicable, there is no other express warranty. All implied warranties of merchantability and fitness for use are limited to the duration of this express warranty.

Some states do not allow exclusions of incidental or consequential damages, or limitations on how long an implied warranty lasts, so the above exclusions and limitations may not apply to you. This warranty gives you specific legal rights, and you may also have other rights which vary from state to state.

Note regarding engine warranty:

The Emissions Control System on your Product may be covered by a separate warranty meeting requirements established by the U.S. Environmental Protection Agency (EPA) and/or the California Air Resources Board (CARB). The hour limitations set forth above do not apply to the Emissions Control System Warranty. Refer to the Engine Emission Control Warranty Statement supplied with your product or contained in the engine manufacturer's documentation for details