



Count on it.

Operator's Manual

Dingo® 220 Compact Utility Loader

Model No. 22317—Serial No. 31200001 and Up

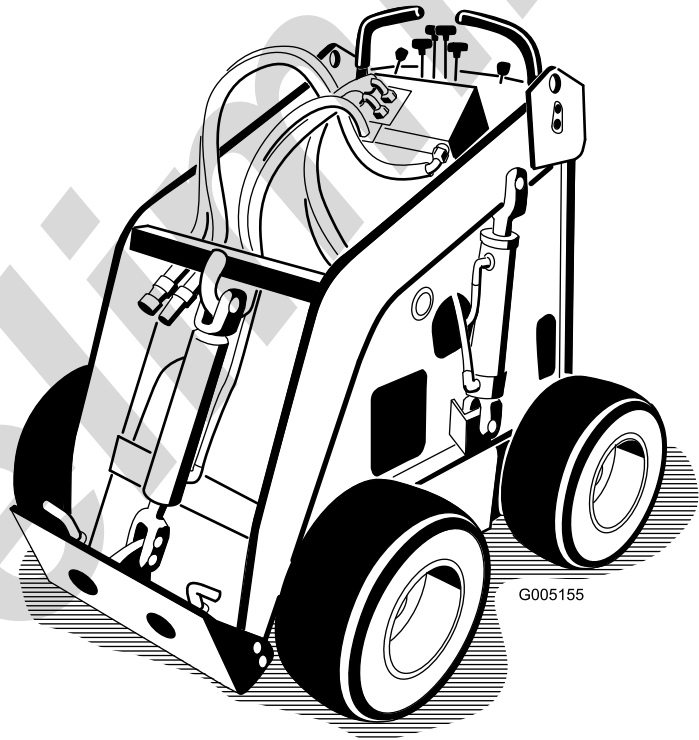

This product complies with all relevant European directives, for details please see the separate product specific Declaration of Conformity (DOC) sheet.

WARNING

CALIFORNIA Proposition 65 Warning

The engine exhaust from this product contains chemicals known to the State of California to cause cancer, birth defects, or other reproductive harm.

Because in some areas there are local, state, or federal regulations requiring that a spark arrester be used on the engine of this machine, a spark arrester is available as an option. If you require a spark arrester, contact your Authorized Toro Service Dealer.

Genuine Toro spark arresters are approved by the USDA Forestry Service.

Important: It is a violation of California Public Resource Code Section 4442 to use or operate the engine on any forest-covered, brush-covered, or grass-covered land without a spark arrester muffler maintained in working order, or the engine constricted, equipped, and maintained for the prevention of fire. Other states or federal areas may have similar laws.

This spark ignition system complies with Canadian ICES-002.

The enclosed *Engine Owner's Manual* is supplied for information regarding the US Environmental Protection Agency (EPA) and the California Emission Control Regulation of emission systems, maintenance, and warranty. Replacements may be ordered through the engine manufacturer.

Introduction

This machine is a compact utility loader intended for use in various earth and materials moving activities for landscaping and construction work. It is designed to operate a wide variety of attachments each of which perform a specialized function.

Read this information carefully to learn how to operate and maintain your product properly and to avoid injury and product damage. You are responsible for operating the product properly and safely.

You may contact Toro directly at www.Toro.com for product and accessory information, help finding a dealer, or to register your product.

Whenever you need service, genuine Toro parts, or additional information, contact an Authorized Service Dealer or Toro

Customer Service and have the model and serial numbers of your product ready. Figure 1 identifies the location of the model and serial numbers on the product. Write the numbers in the space provided.

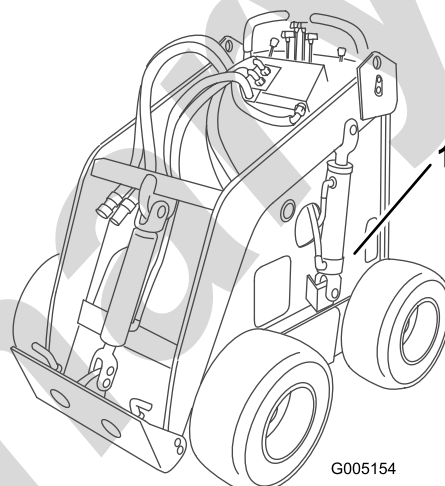

Figure 1

1. Model and serial number location

Model No. _____

Serial No. _____

This manual identifies potential hazards and has safety messages identified by the safety alert symbol (Figure 2), which signals a hazard that may cause serious injury or death if you do not follow the recommended precautions.



Figure 2

1. Safety alert symbol

This manual uses 2 other words to highlight information.

Important calls attention to special mechanical information and **Note** emphasizes general information worthy of special attention.

Contents

Introduction	2
Safety	3
Safe Operating Practices	3
Slope Indicator	6
Safety and Instructional Decals	7
Setup	9
1 Installing the Valve Lever	9
2 Checking Fluid Levels and Drive Chain Tension	9
3 Charging the Battery.....	9
Product Overview	11
Controls	11
Specifications	13
Attachments/Accessories.....	13
Stability Data	14
Operation	15
Adding Fuel.....	15
Checking the Engine Oil Level	16
Removing Debris from the Traction Unit.....	16
Checking the Hydraulic Fluid Level.....	16
Checking the Tire Pressure	17
Starting and Stopping the Engine.....	17
Driving the Traction Unit	17
Stopping the Traction Unit	18
Moving a Non-functioning Traction Unit.....	18
Using the Cylinder Locks.....	18
Using Attachments	19
Securing the Traction Unit for Transport.....	20
Adjusting the Thigh Support.....	20
Maintenance	21
Recommended Maintenance Schedule(s)	21
Lubrication	22
Greasing the Traction Unit	22
Engine Maintenance	22
Servicing the Air Cleaner	22
Servicing the Carbon Canister	23
Servicing the Engine Oil.....	24
Servicing the Spark Plugs.....	25
Fuel System Maintenance	26
Changing the Fuel Filter	26
Draining the Fuel Tank	26
Electrical System Maintenance	27
Replacing the Battery	27
Servicing the Battery.....	28
Drive System Maintenance	29
Servicing the Traction Drive Chains	29
Hydraulic System Maintenance	31
Replacing the Hydraulic Filter	31
Changing the Hydraulic Fluid.....	31
Checking the Hydraulic Lines.....	32
Storage	32
Troubleshooting	34
Schematics	35

Safety

Improper use or maintenance by the operator or owner can result in injury. To reduce the potential for injury, comply with these safety instructions and always pay attention to the safety alert symbol , which means: *Caution, Warning, or Danger*—personal safety instruction. Failure to comply with the instruction may result in personal injury or death.

Safe Operating Practices

This product is capable of amputating hands and feet. Always follow all safety instructions to avoid serious injury or death.

WARNING

Engine exhaust contains carbon monoxide, an odorless, deadly poison that can kill you.

Do not run the engine indoors or in an enclosed area.

Training

- Read the *Operator's Manual* and other training material. If the operator(s) or mechanic(s) can not read English, it is the owner's responsibility to explain this material to them.
- Become familiar with the safe operation of the equipment, operator controls, and safety signs.
- All operators and mechanics should be trained. The owner is responsible for training the users.
- Never let children or untrained people operate or service the equipment. Local regulations may restrict the age of the operator.
- The owner/user can prevent and is responsible for accidents or injuries occurring to himself or herself, other people or property.

Preparation

- Evaluate the terrain to determine what accessories and attachments are needed to properly and safely perform the job. Only use accessories and attachments approved by the manufacturer.
- Wear appropriate clothing including hard hat, safety glasses, long pants, safety shoes, and hearing protection. Long hair, loose clothing or jewelry may get tangled in moving parts.
- Inspect the area where the equipment is to be used and remove all objects such as rocks, toys, and wire which can be thrown by the machine.
- Use extra care when handling gasoline and other fuels. They are flammable and vapors are explosive.
 - Use only an approved container
 - Never remove the gas cap or add fuel with the engine running. Allow the engine to cool before refueling. Do not smoke.

- Never refuel or drain the machine indoors.
- Check that the operator's presence controls, safety switches, and shields are attached and functioning properly. Do not operate unless they are functioning properly.

Operation

- Never run an engine in an enclosed area.
- Only operate in good light, keeping away from holes and hidden hazards.
- Be sure all drives are in neutral before starting the engine. Only start the engine from the operator's position.
- Slow down and use extra care on hillsides. Be sure to travel in the recommended direction on hillsides. Turf conditions can affect the machine's stability.
- Slow down and use caution when making turns and when changing directions on slopes.
- Never operate with the guards not securely in place. Be sure all interlocks are attached, adjusted properly, and functioning properly.
- Do not change the engine governor setting or overspeed the engine.
- Stop on level ground, lower implements, disengage the auxiliary hydraulics, and shut off the engine before leaving the operator's position for any reason.
- Keep hands and feet away from moving attachments.
- Look behind and down before backing up to be sure of a clear path.
- Never carry passengers and keep pets and bystanders away.
- Slow down and use caution when making turns and crossing roads and sidewalks.
- Do not operate the machine under the influence of alcohol or drugs.
- Use care when loading or unloading the machine into a trailer or truck.
- Use care when approaching blind corners, shrubs, trees, or other objects that may obscure vision.
- Read all attachment manuals.
- Ensure that the area is clear of other people before operating the traction unit. Stop the traction unit if anyone enters the area.
- Never leave a running traction unit unattended. Always lower the loader arms, stop the engine, and remove the key before leaving.
- Do not exceed the rated operating capacity, as the traction unit may become unstable which may result in loss of control.
- Do not carry a load with the arms raised. Always carry loads close to the ground.
- Do not over-load the attachment and always keep the load level when raising the loader arms. Logs, boards, and other items could roll down the loader arms, injuring you.

- Never jerk the controls; use a steady motion.
- Watch for traffic when operating near or crossing roadways.
- Do not touch parts which may be hot from operation. Allow them to cool before attempting to maintain, adjust, or service.
- Check for overhead clearances (i.e. branches, doorways, electrical wires) before driving under any objects and do not contact them.
- Ensure that you operate the traction unit in areas where there are no obstacles in close proximity to the operator. Failure to maintain adequate distance from trees, walls, and other barriers may result in injury as the traction unit backs up during operation if the operator is not attentive to the surroundings. Only operate the unit in areas where there is sufficient clearance for the operator to safely maneuver the product.
- Before digging, have the area marked for underground utilities, and do not dig in marked areas.
- Locate the pinch point areas marked on the traction unit and attachments and keep hands and feet away from these areas.
- Before operating the traction unit with an attachment, ensure that the attachment is properly installed.
- Do not place your feet under the platform.
- Lightning can cause severe injury or death. If lightning is seen or thunder is heard in the area, do not operate the machine; seek shelter.

Slope Operation

Slopes are a major factor related to loss-of-control and tip-over accidents, which can result in severe injury or death. All slopes require extra caution.

- Do not operate the traction unit on hillsides or slopes exceeding the angles recommended in Stability Data (page 14), and those in the attachment *Operator's Manual*. See also the Slope Indicator (page 6).
- **Operate up and down slopes with the heavy end of the traction unit uphill.** Weight distribution changes. An empty bucket will make the rear of the traction unit the heavy end, and a full bucket will make the front of the traction unit the heavy end. Most other attachments will make the front of traction unit the heavy end.
- Raising the loader arms on a slope will affect the stability of the machine. Whenever possible, keep the loader arms in the lowered position when on slopes.
- Removing an attachment on a slope will make the rear of the traction unit heavy. Refer to Stability Data (page 14), to determine whether the attachment can be safely removed on the slope.
- Remove obstacles such as rocks, tree limbs, etc. from the work area. Watch for holes, ruts, or bumps, as uneven terrain could overturn the traction unit. Tall grass can hide obstacles.

- Use only Toro-approved attachments. Attachments can change the stability and the operating characteristics of the traction unit. Warranty may be voided if used with unapproved attachments.
- Keep all movements on slopes slow and gradual. Do not make sudden changes in speed or direction.
- Avoid starting or stopping on a slope. If the traction unit loses traction, proceed slowly, straight down the slope.
- Avoid turning on slopes. If you must turn, turn slowly and keep the heavy end of the traction unit uphill.
- Do not operate near drop-offs, ditches, or embankments. The traction unit could suddenly turn over if a wheel goes over the edge of a cliff or ditch, or if an edge caves in.
- Do not operate on wet grass. Reduced traction could cause sliding.
- Do not park the traction unit on a hillside or slope without lowering the attachment to the ground and chocking the wheels.
- Do not try to stabilize the traction unit by putting your foot on the ground.
- Keep nuts and bolts tight. Keep equipment in good condition.
- Never tamper with safety devices.
- Keep the traction unit free of grass, leaves, or other debris build-up. Clean up oil or fuel spillage. Allow the traction unit to cool before storing.
- Use extra care when handling gasoline and other fuels. They are flammable and vapors are explosive.
 - Use only an approved container.
 - Never remove the gas cap or add fuel when the engine is running. Allow the engine to cool before refueling. Do not smoke.
 - Never refuel the traction unit indoors.
 - Never store the traction unit or fuel container inside where there is an open flame, such as near a water heater or furnace.
 - Never fill a container while it is inside a vehicle, trunk, pick-up bed, or any surface other than the ground.
 - Keep container nozzle in contact with the tank during filling.

Maintenance and Storage

- Disengage the auxiliary hydraulics, lower the attachment, stop the engine, and remove the key. Wait for all movement to stop before adjusting, cleaning, or repairing.
- Clean debris from attachments, drives, mufflers, and engine to help prevent fires. Clean up oil or fuel spillage.
- Let the engine cool before storing and do not store near flame.
- Do not store fuel near flames or drain indoors.
- Park the machine on level ground. Never allow untrained personnel to service the machine.
- Use jack stands to support components when required.
- Carefully release pressure from components with stored energy.
- Disconnect the battery or remove the spark plug wires before making any repairs. Disconnect the negative terminal first and the positive last. Reconnect positive first and negative last.
- Keep hands and feet away from moving parts. If possible, do not make adjustments with the engine running.
- Charge batteries in an open well ventilated area, away from spark and flames. Unplug the charger before connecting or disconnecting it from the battery. Wear protective clothing and use insulated tools.
- Keep all parts in good working condition and all hardware tightened. Replace all worn or damaged decals.
- If any maintenance or repair requires the loader arms to be in the raised position, secure the arms in the raised position with the hydraulic cylinder lock.
- Stop and inspect the equipment if you strike an object. Make any necessary repairs before restarting.
- Use only genuine Toro replacement parts to ensure that original standards are maintained.
- Battery acid is poisonous and can cause burns. Avoid contact with skin, eyes, and clothing. Protect your face, eyes, and clothing when working with a battery.
- Battery gases can explode. Keep cigarettes, sparks and flames away from the battery.
- Keep your body and hands away from pin hole leaks or nozzles that eject high pressure hydraulic fluid. Use cardboard or paper to find hydraulic leaks; never use your hands. Hydraulic fluid escaping under pressure can penetrate skin and cause injury requiring surgery within a few hours by a qualified surgeon or gangrene may result.

Slope Indicator

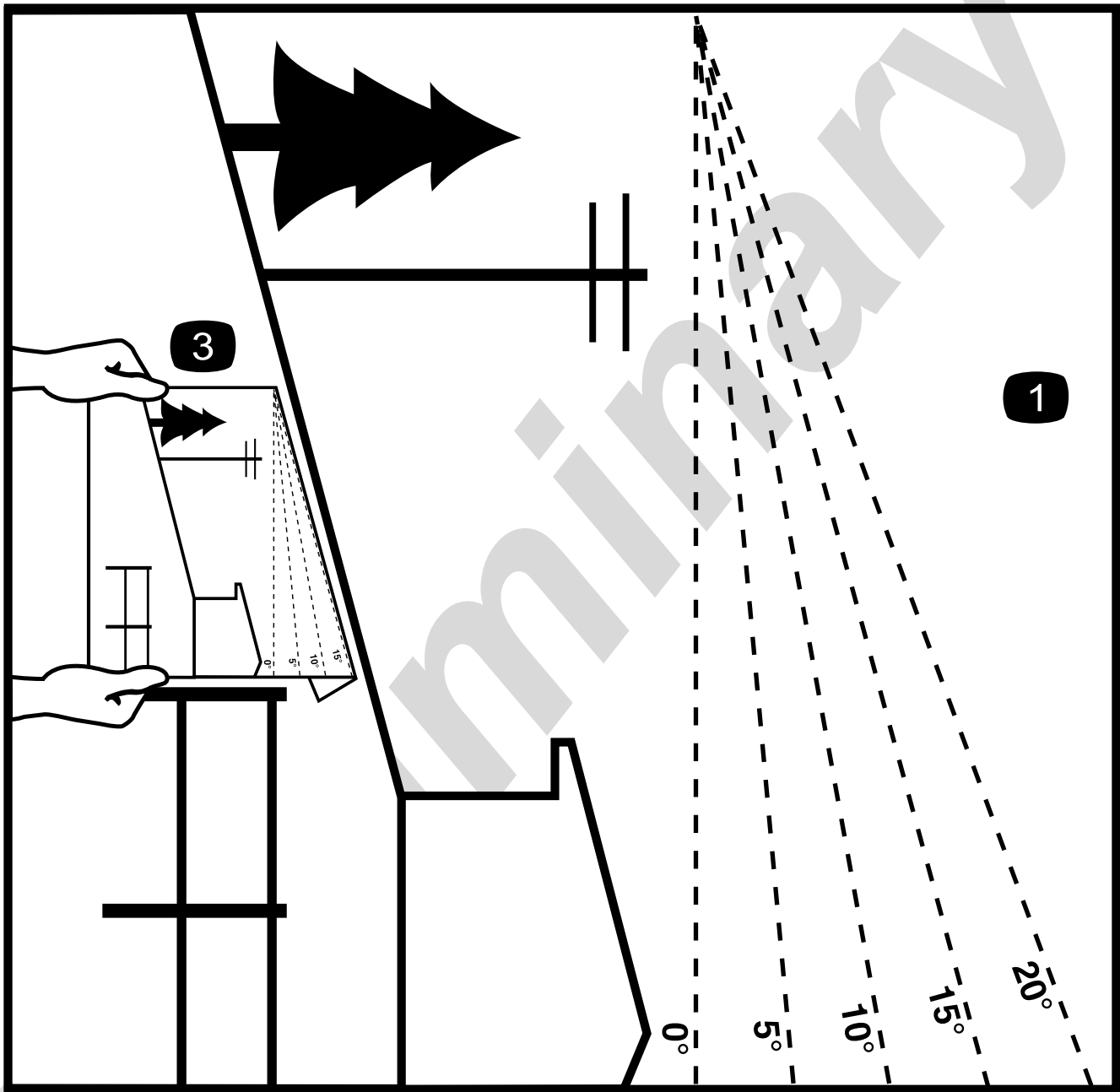

G011841

2

Figure 3

This page may be copied for personal use.

1. To determine the maximum slope you can safely operate the machine on, refer to the Stability Data section. Use the slope indicator to determine the degree of slope of hills before operating. **Do not operate this machine on a slope greater than that specified in the Stability Data section.** Fold along the appropriate line to match the recommended slope.
2. Align this edge with a vertical surface, a tree, building, fence pole, etc.
3. Example of how to compare slope with folded edge.

Safety and Instructional Decals



Safety decals and instructions are easily visible to the operator and are located near any area of potential danger. Replace any decal that is damaged or lost.

⚠ DANGER TO MINIMIZE THE RISK OF ACCIDENTS, INJURY, OR DEATH:

- OPERATOR MUST BE SKILLED AND TRAINED IN OPERATION.
- NEVER USE WHEN UNDER THE INFLUENCE OF ALCOHOL OR DRUGS.
- USE SAFELY, MACHINE IS NOT A TOY.
- STOP ENGINE AND REMOVE KEY BEFORE LEAVING MACHINE. WAIT FOR ALL MOVEMENT TO STOP BEFORE SERVICING.
- USE CYLINDER LOCKS IF SERVICING WHILE LIFT ARMS ARE RAISED.
- KEEP GUARDS, COVERS AND OTHER SAFETY DEVICES IN PLACE.
- WEAR CLOSE FITTING PROTECTIVE CLOTHING AND SHOES.
- KEEP HANDS, FEET AND CLOTHING AWAY FROM ALL MOVING PARTS.
- NEVER SMOKE WHILE FUELING. STOP ENGINE BEFORE FUELING.
- NEVER RUN ENGINE WITHOUT ADEQUATE VENTILATION.
- KEEP CHILDREN AND OTHER PEOPLE A SAFE DISTANCE AWAY.
- NEVER LET CHILDREN OPERATE THE MACHINE.
- NEVER CARRY CHILDREN OR OTHER PASSENGERS.
- LOOK DOWN AND BEHIND BEFORE AND WHILE BACKING UP.
- GO SLOW AND AVOID SHARP TURNS ON SLOPES.
- ALWAYS PLACE IMPLEMENT ON GROUND WHEN LEAVING MACHINE. USE WHEEL CHOCKS WHEN PARKING ON A SLOPE.
- FIRMLY HOLD THE GRAB HANDLES WHEN OPERATING. NEVER PLACE FEET UNDER THE PLATFORM.
- KNOW THE WORK AREA. CHECK FOR HOLES AND OVERHEAD CLEARANCES. AVOID OVERHEAD POWER LINES.
- KNOW LOCATION OF UNDERGROUND UTILITIES BEFORE YOU DIG.

98-9051

⚠ DANGER

TO MINIMIZE THE RISK OF ACCIDENTS:

- ALWAYS OPERATE WITH HEAVY END POINTED UP HILL.
- ALWAYS CARRY LOADS LOW.
- NEVER STEP OFF OPERATOR PLATFORM WITH LOAD RAISED.
- NEVER JERK THE CONTROL LEVERS. USE A STEADY, EVEN MOTION.
- NEVER OPERATE THE CONTROL LEVERS UNLESS YOU ARE STANDING WITH BOTH FEET ON THE PLATFORM AND FIRMLY HOLDING THE GRIP HANDLES.

READ OPERATOR'S MANUAL.
REPLACEMENT MANUAL AVAILABLE BY SENDING
COMPLETE MODEL NUMBER TO: THE FORD COMPANY,
8111 LYNDALE AVE. S., BLOOMINGTON, MN 55205-1198

108-9732



93-6686

HYDRAULIC OIL:
USE SAE 10W30 OR 15W40
DIESEL ENGINE OIL, API SERVICE
CH-4 OR HIGHER.

105-8432

1. Hydraulic oil
2. Read the Operator's Manual.

⚠ CAUTION

SECURE QUICK ATTACH BEFORE OPERATING MACHINE. RATED OPERATING CAPACITY: 515 LBS.

98-4682

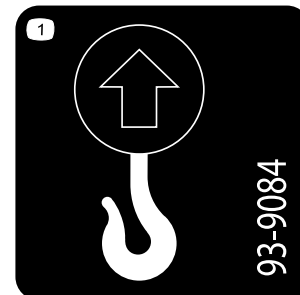

93-9084

1. Lift point

⚠ WARNING

PINCH AREA, KEEP CLEAR

100-6141

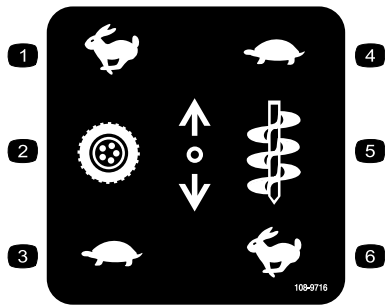

108-9716

- | | |
|-------------------|---------------------|
| 1. Fast | 4. Slow |
| 2. Traction drive | 5. Attachment speed |
| 3. Slow | 6. Fast |

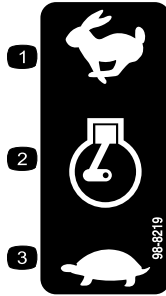

98-8219

- | | |
|-------------|---------|
| 1. Fast | 3. Slow |
| 2. Throttle | |



94-2551

- | | |
|----------|--------|
| 1. On | 3. Off |
| 2. Choke | |

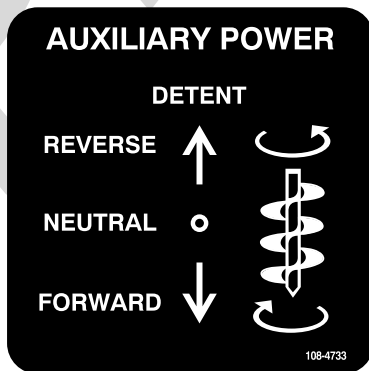

108-4733



Battery Symbols

Some or all of these symbols are on your battery

- | | |
|----------------------------------------|--------------------------------------------------------------------------------|
| 1. Explosion hazard | 6. Keep bystanders a safe distance from the battery. |
| 2. No fire, open flame, or smoking. | 7. Wear eye protection; explosive gases can cause blindness and other injuries |
| 3. Caustic liquid/chemical burn hazard | 8. Battery acid can cause blindness or severe burns. |
| 4. Wear eye protection | 9. Flush eyes immediately with water and get medical help fast. |
| 5. Read the <i>Operator's Manual</i> . | 10. Contains lead; do not discard. |

Setup

1

Installing the Valve Lever

Parts needed for this procedure:

1	Speed selector valve lever
---	----------------------------

Procedure

1. Remove and discard the nut securing the bolt and lock washer to the speed selector lever.
2. Secure the lever to the speed selector valve using the bolt and lock washer as illustrated in Figure 4.

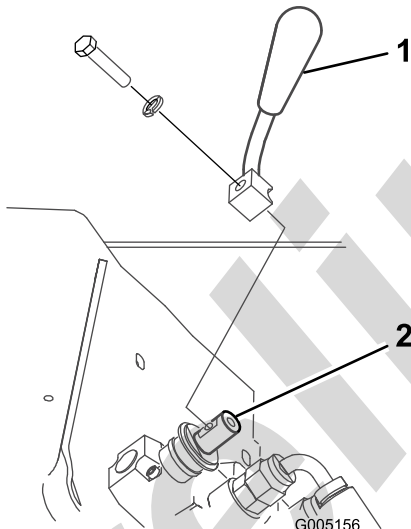

Figure 4

1. Speed selector valve lever 2. Speed selector valve

2

Checking Fluid Levels and Drive Chain Tension

No Parts Required

Procedure

Before starting the engine for the first time, check the engine oil and hydraulic fluid levels and the traction drive chain tension. Refer to the following sections for more information:

- Checking the Engine Oil Level (page 16)
- Checking the Hydraulic Fluid Level (page 16)
- Servicing the Traction Drive Chains (page 29)

3

Charging the Battery

No Parts Required

Procedure

WARNING

CALIFORNIA Proposition 65 Warning

Battery posts, terminals, and related accessories contain lead and lead compounds, chemicals known to the State of California to cause cancer and reproductive harm.
Wash hands after handling.

⚠ WARNING

Battery terminals or metal tools could short against metal components, causing sparks. Sparks can cause the battery gasses to explode, resulting in personal injury.

- When removing or installing the battery, do not allow the battery terminals to touch any metal parts of the traction unit.
 - Do not allow metal tools to short between the battery terminals and metal parts of the traction unit.
1. Park the traction unit on a level surface, raise the loader arms, and install the cylinder locks.
 2. Stop the engine and remove the key.
 3. Connect a charger to the battery (Figure 5) and charge it for a minimum of 1 hour at 6 to 10 amps. Do not overcharge the battery.

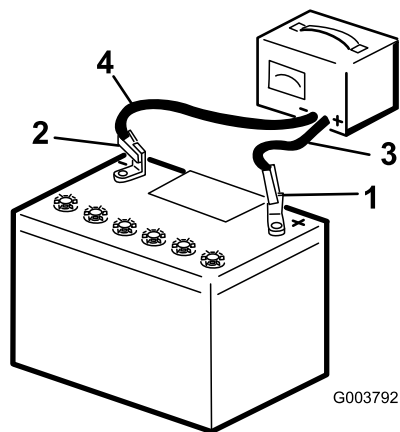

Figure 5

1. Positive post
2. Negative post
3. Charger red (+) wire
4. Charger black (—) wire

⚠ WARNING

Charging the battery produces gasses that can explode.

Never smoke near the battery and keep sparks and flames away from battery.

4. When the battery is fully charged, unplug the charger from the electrical outlet, then disconnect the charger leads from the battery posts (Figure 5).

Product Overview

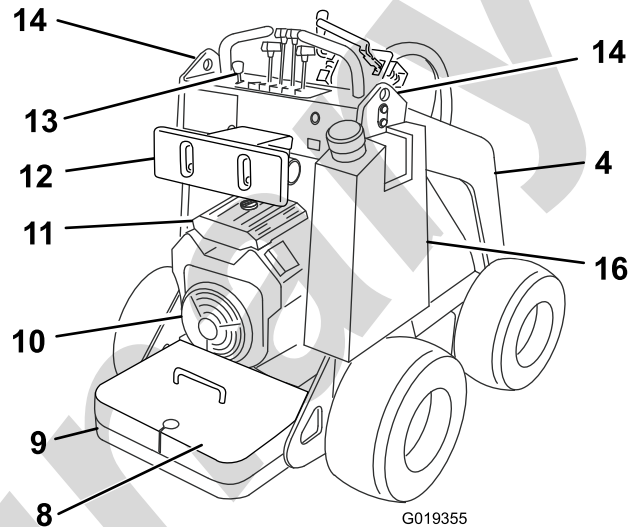
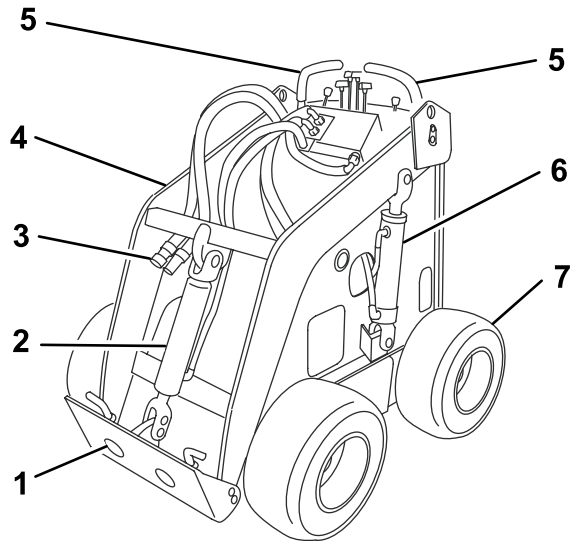

Figure 6

- | | | | |
|---------------------------------|------------------|----------------------|-------------------|
| 1. Mount plate | 5. Handles | 9. Operator platform | 13. Control panel |
| 2. Tilt cylinder | 6. Lift cylinder | 10. Engine | 14. Lift points |
| 3. Auxiliary hydraulic couplers | 7. Wheel | 11. Air cleaner | 15. Fuel tank |
| 4. Loader arms | 8. Counterweight | 12. Thigh support | |

Controls

Become familiar with all the controls (Figure 7) before you start the engine and operate the traction unit.

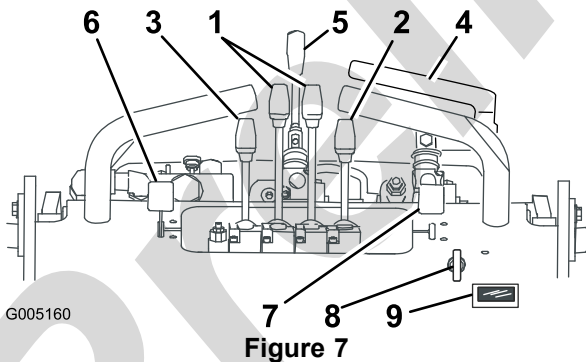

Figure 7

- | | |
|-------------------------------|-------------------|
| 1. Traction control levers | 6. Throttle lever |
| 2. Attachment tilt lever | 7. Choke lever |
| 3. Loader arm lever | 8. Key switch |
| 4. Auxiliary hydraulics lever | 9. Hour meter |
| 5. Speed selector lever | |

Key Switch

The key switch, used to start and stop the engine, has three positions: off, run, and start.

To start the engine, rotate the key to the start position. Release the key when engine starts and it will move automatically to the run position.

To stop the engine, rotate the key to the off position.

Throttle Lever

Move the control forward to increase the engine speed and rearward to decrease speed.

Choke Lever

Before starting a cold engine, move the choke lever forward. After the engine starts, regulate the choke to keep the engine running smoothly. As soon as possible, move the choke lever all the way rearward.

Note: A warm engine requires little or no choking.

Traction Control Levers

To move forward, move the traction control levers forward. To move rearward, move the traction control levers rearward.

To go straight, move both traction control levers equally.

To turn, move the lever located on the side you want to turn back toward the neutral position while keeping the other lever engaged.

The farther you move the traction control levers in either direction, the faster the traction unit will move in that direction.

To slow or stop, move the traction control levers to neutral.

Attachment Tilt Lever

To tilt the attachment forward, slowly push the attachment tilt lever forward.

To tilt the attachment rearward, slowly pull the attachment tilt lever rearward.

Loader Arm Lever

To lower the loader arms, slowly push the loader arm lever forward.

To raise the loader arms, slowly pull the loader arm lever rearward.

Auxiliary Hydraulics Lever

To operate a hydraulic attachment in forward direction, slowly pull the auxiliary hydraulics lever upward and then rearward.

To operate a hydraulic attachment in reverse direction, slowly pull the auxiliary hydraulics lever upward and then push it forward. This is also called the detent position because it does not require operator presence.

Speed Selector Lever

Move the speed selector lever to the forward position to set the traction drive, loader arms, and attachment tilt to high speed and the auxiliary hydraulics to low speed.

Move the speed selector lever to the rearward position to set the auxiliary hydraulics to high speed and the traction drive, loader arms, and attachment tilt to low speed.

▲ WARNING

If you move the speed selector lever while the traction unit is in motion, the traction unit will either stop suddenly or accelerate quickly. If you operate the traction unit with the speed selector lever in an intermediate position, the traction unit will operate erratically and may be damaged. You could lose control of the traction unit and injure bystanders or yourself.

- **Do not move the speed selector lever when the traction unit is in motion.**
- **Do not operate the traction unit when the speed selector is in any intermediate position (i.e., any position other than fully forward or fully rearward).**

Hour Meter

The hour meter displays the number of hours of operation that have been logged on the traction unit.

After 50 hours and then every 100 hours thereafter (that is at 150, 250, 350, etc.) the screen displays CHG OIL to remind

you to change the oil. After every 100 hours, the screen displays SVC to remind you to perform the other maintenance procedures based on a 100, 200, or 400 hour schedule. These reminders come on starting three hours prior to the service interval time and flash at regular intervals for six hours.

Specifications

Note: Specifications and design are subject to change without notice.

Width	40.5 inches (103 cm)
Length	60 inches (152 cm)
Height	49 inches (125 cm)
Weight (without attachment or counterweight)	1430 lb (649 Kg)
Weight of the counterweight	165 lb (75 Kg)
Operating capacity (with 200 lb operator, the standard bucket, and without the counterweight)	515 lb (234 Kg)
Tipping capacity (with 200 lb operator, the standard bucket, and without the counterweight)	1030 lb (467 Kg)
Wheelbase	28 inches (71 cm)
Dump height (with standard bucket)	47 inches (120 cm)
Reach—fully raised (with standard bucket)	26 inches (66 cm)
Height to hinge pin (narrow bucket in standard position)	66 inches (168 cm)

Attachments/Accessories



A selection of Toro approved attachments and accessories are available for use with the machine to enhance and expand its capabilities. Contact your Authorized Service Dealer or Distributor or go to www.Toro.com for a list of all approved attachments and accessories.

Important: Use only Toro approved attachments. Other attachments may create an unsafe operating environment or damage the traction unit.

Stability Data

The following tables list the maximum slope recommended for the traction unit in the positions listed in the tables. Slopes over the listed degree may cause the traction unit to become unstable. The data in the tables assume that the loader arms are fully lowered; raised arms may affect the stability.

In each attachment manual is a set of three stability ratings, one for each hill position. To determine the maximum slope you can traverse with the attachment installed, find the degree of slope that corresponds to the stability ratings of the attachment. Example: If the attachment has a Front Uphill rating of B, a Rear Uphill rating of D, and a Side Uphill rating of C, then you could drive forward up an 18° slope, rearward up a 10° slope, or sideways on a 14° slope, as listed in the following table.

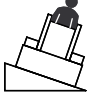
Configuration	Maximum Recommended Slope when Operating with:		
	Front Uphill 	Rear Uphill 	Side Uphill 
Traction unit without attachment	8°	20°	17°
Traction unit with counterweight, without attachment	5°	21°	17°
Traction unit with an attachment rated with one of the following stability ratings for each slope position:*			
A	25°	25°	20°
B	18°	19°	17°
C	15°	16°	14°
D	10°	10°	9°
E	5°	5°	5°

Operation

Note: Determine the left and right sides of the machine from the normal operating position.

Important: Before operating, check the fuel and oil level, remove debris from the traction unit, and check the tire pressure. Also, ensure that the area is clear of people and debris. You should also know and have marked the locations of all utility lines.

⚠ CAUTION

You could fall off of the platform and be seriously injured during operation.

Do not move the control levers unless you are standing with both feet on the platform and your hands are holding the handles.

Adding Fuel

- For best results, use only clean, fresh, unleaded gasoline with an octane rating of 87 or higher ((R+M)/2 rating method).
- Oxygenated fuel with up to 10% ethanol or 15% MTBE by volume is acceptable.
- **Do Not** use ethanol blends of gasoline (such as E15 or E85) with more than 10% ethanol by volume. Performance problems and/or engine damage may result which may not be covered under warranty.
- **Do Not** use gasoline containing methanol.
- **Do Not** store fuel either in the fuel tank or fuel containers over the winter unless a fuel stabilizer is used.
- **Do Not** add oil to gasoline.

⚠ DANGER

In certain conditions, gasoline is extremely flammable and highly explosive. A fire or explosion from gasoline can burn you and others and can damage property.

- Fill the fuel tank outdoors, in an open area, when the engine is cold. Wipe up any gasoline that spills.
- Never fill the fuel tank inside an enclosed trailer.
- Do not fill the fuel tank completely full. Add gasoline to the fuel tank until the level is 1/4 to 1/2 inch (6 to 13 mm) below the bottom of the filler neck. This empty space in the tank allows gasoline to expand.
- Never smoke when handling gasoline, and stay away from an open flame or where gasoline fumes may be ignited by a spark.
- Store gasoline in an approved container and keep it out of the reach of children. Never buy more than a 30-day supply of gasoline.
- Do not operate without entire exhaust system in place and in proper working condition.

⚠ DANGER

In certain conditions during fueling, static electricity can be released causing a spark which can ignite the gasoline vapors. A fire or explosion from gasoline can burn you and others and can damage property.

- Always place gasoline containers on the ground away from your vehicle before filling.
- Do not fill gasoline containers inside a vehicle or on a truck or trailer bed because interior carpets or plastic truck bed liners may insulate the container and slow the loss of any static charge.
- When practical, remove gas-powered equipment from the truck or trailer and refuel the equipment with its wheels on the ground.
- If this is not possible, then refuel such equipment on a truck or trailer from a portable container, rather than from a gasoline dispenser nozzle.
- If a gasoline dispenser nozzle must be used, keep the nozzle in contact with the rim of the fuel tank or container opening at all times until fueling is complete.

Using Stabilizer/Conditioner

Use a fuel stabilizer/conditioner in the traction unit to provide the following benefits:

- Keeps gasoline fresh during storage of 90 days or less. For longer storage it is recommended that the fuel tank be drained.
- Cleans the engine while it runs
- Eliminates gum-like varnish buildup in the fuel system, which causes hard starting

Important: Do not use fuel additives containing methanol or ethanol.

Add the correct amount of gas stabilizer/conditioner to the gas.

Note: A fuel stabilizer/conditioner is most effective when mixed with fresh gasoline. To minimize the chance of varnish deposits in the fuel system, use fuel stabilizer at all times.

Filling the Fuel Tank

1. Park the traction unit on a level surface, lower the loader arms, and stop the engine.
2. Remove the key and allow the engine to cool.
3. Clean around the fuel tank cap and remove it.

Note: The cap is tethered to the fuel tank.

4. Add unleaded gasoline to the fuel tank, until the level is 1/4 to 1/2 inch (6 to 13 mm) below the bottom of the filler neck.

Important: This space in the tank allows gasoline to expand. Do not fill the fuel tank completely full.

5. Install the fuel tank cap securely, turning it until it clicks.
6. Wipe up any gasoline that may have spilled.

Checking the Engine Oil Level

Service Interval: Before each use or daily

1. Park the traction unit on a level surface, lower the loader arms, and stop the engine.
2. Remove the key and allow the engine to cool.
3. Clean around the oil dipstick (Figure 8).

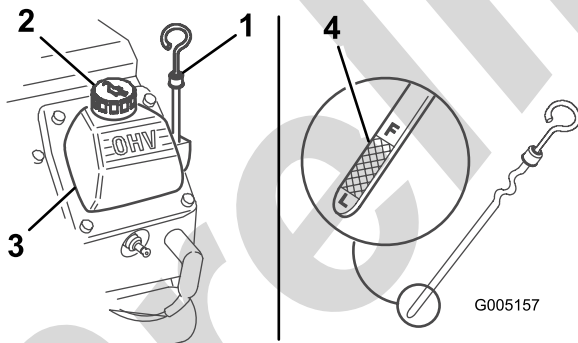

Figure 8

- | | |
|-----------------|----------------|
| 1. Oil dipstick | 3. Valve cover |
| 2. Filler cap | 4. Metal end |
-
4. Pull out the dipstick and wipe the metal end clean (Figure 8).
 5. Slide the dipstick fully into the dipstick tube (Figure 8).
 6. Pull the dipstick out and look at the metal end.
 7. If the oil level is low, clean around the oil filler cap and remove the cap (Figure 8).
 8. Slowly pour only enough oil into the valve cover to raise the level to the F (full) mark.

Important: Do not overfill the crankcase with oil because the engine may be damaged.

9. Replace the filler cap and dipstick.

Removing Debris from the Traction Unit

Service Interval: Before each use or daily

Important: Operating the engine with a blocked grass screen, dirty or plugged cooling fins, and/or cooling shrouds removed, will result in engine damage from overheating.

1. Park the traction unit on a level surface, raise the loader arms, and install the cylinder locks.
2. Stop the engine and remove the key.
3. Clean any debris from the grill before each use and/or during use, if required.
4. Wipe away debris from the air cleaner before each use and/or during use, if required.
5. Clean any debris build-up on the engine with a brush or blower before each use.

Important: It is preferable to blow dirt out, rather than washing it out. If water is used, keep it away from electrical items and hydraulic valves. Do not use a high-pressure washer. High-pressure washing can damage the electrical system and hydraulic valves or deplete grease.

6. Remove and store the cylinder locks and lower the loader arms.

Checking the Hydraulic Fluid Level

Service Interval: Every 25 hours

Check the hydraulic fluid level before the engine is first started and after every 25 operating hours.

Hydraulic Tank Capacity: 16.25 US gallons (62 l)

Refer to Changing the Hydraulic Fluid (page 31) for hydraulic fluid specifications.

Important: Always use the correct hydraulic fluid. Unspecified fluids will damage the hydraulic system.

1. Remove the attachment, if one is installed.
2. Park the traction unit on a level surface, raise the loader arms, and install the cylinder locks.
3. Stop the engine, remove the key, and allow the engine to cool.
4. Clean the area around the filler neck of the hydraulic tank (Figure 9).
5. Remove the cap from the filler neck and check the fluid level on the dipstick (Figure 9).

The fluid level should be between the marks on the dipstick.

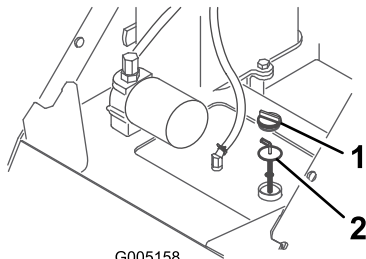

Figure 9

1. Filler neck cap
2. Dipstick

6. If the level is low, add enough fluid to raise it to the proper level.
7. Install the cap on the filler neck.
8. Remove and store the cylinder locks and lower the loader arms.

Checking the Tire Pressure

Service Interval: Before each use or daily

Maintain the air pressure in the tires as specified. Check the tires when they are cold to get the most accurate reading.

Pressure: 15-20 psi

Note: Use a lower tire pressure (15 psi) when operating in sandy soil conditions to provide better traction in the loose soil.

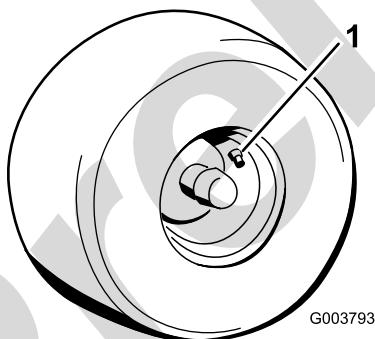

Figure 10

1. Valve stem

Starting and Stopping the Engine

Starting the Engine

1. Stand on the platform.
2. Ensure that the auxiliary hydraulics lever is in neutral.
3. Move the choke lever fully forward if you are starting a cold engine.

Note: A warm or hot engine may not require choking.

4. Move the throttle lever midway between slow (turtle) and fast (rabbit) positions.
5. Turn the ignition key to the start position. When the engine starts, release the key.

Important: Do not engage the starter for more than 10 seconds at a time. If the engine fails to start, allow a 30 second cool-down period between attempts. Failure to follow these instructions can burn out the starter motor.

6. After the engine starts, gradually move the choke rearward. If the engine stalls or hesitates, move the choke forward again until the engine warms up.
7. Move the throttle lever to desired setting.

Important: If you run the engine at high speeds when the hydraulic system is cold (i.e., when the ambient air temperature is near freezing or lower), hydraulic system damage could occur. When starting the engine in cold conditions, allow the engine to run in the middle throttle position for 2 to 5 minutes before moving the throttle to fast (rabbit).

Note: If outdoor temperature is below freezing, store the traction unit in a garage to keep it warmer and aid in starting.

Stopping the Engine

1. Move the throttle lever to 3/4 of the way to the Fast position.
2. Lower the loader arms to the ground.
3. Turn the ignition key off.

Note: If the engine has been working hard or is hot, let it run for a minute before turning the ignition key off. This helps cool the engine before it is stopped. In an emergency, the engine may be stopped immediately.

Driving the Traction Unit

The throttle control regulates the engine speed as measured in rpm (revolutions per minute). Place the throttle lever in the fast (rabbit) position for best performance.

Note: The throttle position can be utilized to operate at slower speeds.

To drive the traction unit, complete the following actions as necessary:

- To move forward, move the traction control levers forward.
- To move rearward, move the traction control levers rearward.
- To go straight, move both traction control levers equally.

- To turn, move the lever located on the side you want to turn toward the neutral position while keeping the other lever engaged.
- To slow or stop, move the traction control levers to neutral.

Note: The farther you move the traction control levers in either direction, the faster the traction unit will move in that direction.

Stopping the Traction Unit

To stop the traction unit, move the traction control levers to neutral, move the throttle lever to slow (turtle), lower loader arms to the ground, and stop the engine. **Remove the key.**

⚠ CAUTION

A child or untrained bystander could attempt to operate the traction unit and be injured.

Remove the key from the switch when leaving the traction unit, even if just for a few seconds.

Moving a Non-functioning Traction Unit

Important: Never tow or pull the traction unit. Rotating the wheels manually will cause damage to the hydraulic wheel motors.

1. Stop the engine.
2. Lift the traction unit off the ground, using the two lift points (Figure 11) and move it onto a trailer.

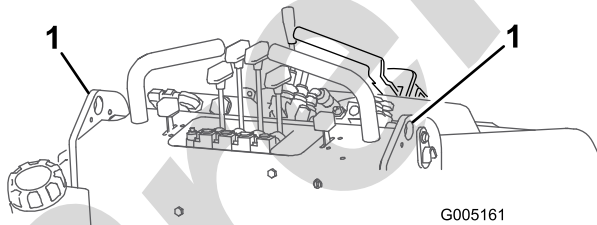

Figure 11

1. Lift points

Using the Cylinder Locks

⚠ WARNING

The loader arms may lower when in the raised position crushing anyone under them.

Install the cylinder locks before performing maintenance that requires raised loader arms.

Installing the Cylinder Locks

1. Start the engine.

2. Raise the loader arms to the fully raised position.
3. Stop the engine.
4. Position a loader arm cylinder lock over each lift cylinder rod (Figure 12).
5. Secure each loader arm cylinder lock with a clevis pin and cotter pin (Figure 12).

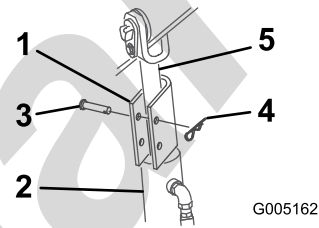

Figure 12

1. Cylinder lock
2. Lift cylinder
3. Hairpin cotter
4. Clevis pin
5. Lift cylinder rod

6. With the engine off, lower the loader arms.

Removing/Storing the Cylinder Lock

1. Start the engine.
2. Raise the loader arms to the fully raised position.
3. Stop the engine.
4. Remove the clevis pin and cotter pin securing each cylinder lock.
5. Remove the cylinder locks.
6. Lower the loader arms.
7. Install the cylinder locks over the hydraulic hoses and secure them with the clevis pins and cotter pins (Figure 13).

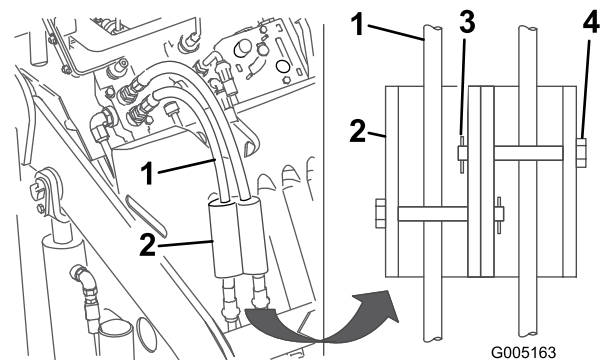

Figure 13

1. Hydraulic hoses
2. Cylinder locks
3. Hairpin cotter
4. Clevis pin

Using Attachments

Installing an Attachment

Important: Use only Toro-approved attachments. Attachments can change the stability and the operating characteristics of the traction unit. The warranty of the traction unit may be voided if used with unapproved attachments.

Important: Before installing the attachment, ensure that the mount plates are free of any dirt or debris and that the pins rotate freely. If the pins do not rotate freely, grease them.

1. Position the attachment on a level surface with enough space behind it to accommodate the traction unit.
2. Start the engine.
3. Tilt the attachment mount plate forward.
4. Position mount plate into the upper lip of the attachment receiver plate (Figure 14).

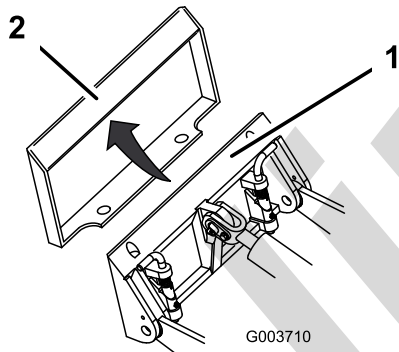

Figure 14

1. Mount plate
2. Receiver plate

5. Raise the loader arms while tilting back the mount plate at the same time.

Important: The attachment should be raised enough to clear the ground, and the mount plate should be tilted all the way back.

6. Stop the engine.
7. Engage the quick attach pins, ensuring that they are fully seated in the mount plate (Figure 15).

Important: If the pins do not rotate to the engaged position, the mount plate is not fully aligned with the holes in the attachment receiver plate. Check the receiver plate and clean it if necessary.

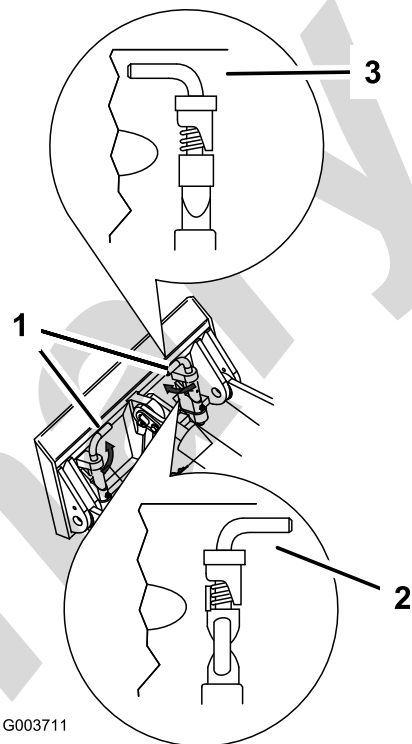

Figure 15

1. Quick attach pins (shown in engaged position)
2. Disengaged position
3. Engaged position

⚠ WARNING

If you do not fully seat the quick attach pins through the attachment mount plate, the attachment could fall off of the traction unit, crushing you or bystanders.

Ensure that your quick attach pins are fully seated in the attachment mount plate.

Connecting the Hydraulic Hoses

If the attachment requires hydraulics for operation, connect the hydraulic hoses as follows:

1. Stop the engine.
2. Move the auxiliary hydraulics lever forward, backward, and back to neutral to relieve pressure at the hydraulic couplers.
3. Move the auxiliary hydraulics lever forward into the detent position.
4. Remove the protective covers from the hydraulic couplers on the traction unit.
5. Ensure that all foreign matter is cleaned from the hydraulic connectors.
6. Push the attachment male connector into the female connector on the traction unit.

Note: When you connect the attachment male connector first, you will relieve any pressure built up in the attachment.

⚠ WARNING

Hydraulic fluid escaping under pressure can penetrate skin and cause injury. Fluid injected into the skin must be surgically removed within a few hours by a doctor familiar with this form of injury or gangrene may result.

- Keep your body and hands away from pin hole leaks or nozzles that eject high pressure hydraulic fluid.
- Use cardboard or paper to find hydraulic leaks, never use your hands.

⚠ CAUTION

Hydraulic couplers, hydraulic lines/valves, and hydraulic fluid may be hot. If you contact hot components you may be burned.

- Wear gloves when operating the hydraulic couplers.
 - Allow the traction unit to cool before touching hydraulic components.
 - Do not touch hydraulic fluid spills.
7. Push the attachment female connector into the male connector on the traction unit.
 8. Confirm that the connection is secure by pulling on the hoses.
 9. Move the auxiliary hydraulics lever to neutral.

Removing an Attachment

1. Lower the attachment to the ground.
2. Stop the engine.
3. Disengage the quick attach pins by turning them to the outside.
4. If the attachment uses hydraulics, move the auxiliary hydraulics lever forward, backward, and back to neutral to relieve pressure at the hydraulic couplers.
5. If the attachment uses hydraulics, slide the collar back on the hydraulic couplers and disconnect them.

Important: Connect the attachment hoses together to prevent hydraulic system contamination during storage.

6. Install the protective covers onto the hydraulic couplers on the traction unit.

7. Start the engine, tilt the mount plate forward, and back the traction unit away from the attachment.

Securing the Traction Unit for Transport

When transporting the traction unit on a trailer, always use the following procedure:

Important: Do not operate or drive the traction unit on roadways.

1. Lower the loader arms.
2. Stop the engine.
3. Secure the traction unit to the trailer with chains or straps using the tie-down/lift loops (Figure 6) to secure the rear of the traction unit and the loader arms/mount plate to secure the front of the traction unit.

Adjusting the Thigh Support

To adjust the thigh support (Figure 16), loosen the knobs and raise or lower the support pad to the desired height. You can also obtain additional adjustment by loosening the nut securing the pad to the adjustment plate, moving the plate up or down as needed. Tighten all fasteners securely when finished.

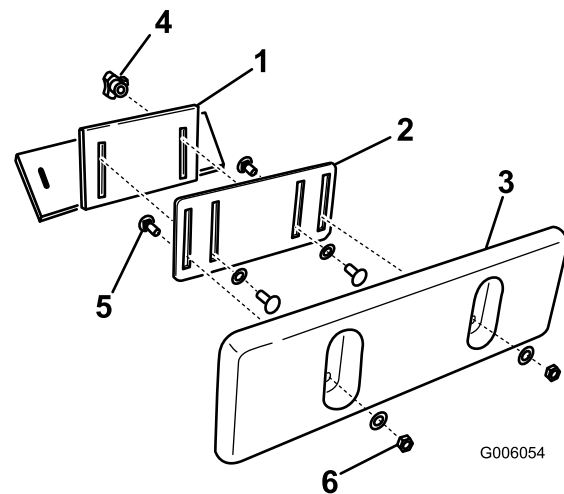

Figure 16

- | | |
|--------------------------|----------------------------|
| 1. Thigh support bracket | 4. Knob and flat washer |
| 2. Adjustment plate | 5. Carriage bolt |
| 3. Thigh support pad | 6. Locknut and flat washer |

Maintenance

Note: Determine the left and right sides of the machine from the normal operating position.

Important: If you will be tilting the machine more than 25 degrees, clamp off the vent hose on the top of the fuel tank to prevent fuel from fouling the carbon canister.

Recommended Maintenance Schedule(s)

Maintenance Service Interval	Maintenance Procedure
After the first 8 hours	<ul style="list-style-type: none">• Replace the hydraulic filter.• Torque the wheel lug nuts to 50 ft-lb (68 N·m).
After the first 50 hours	<ul style="list-style-type: none">• Change the engine oil and filter.
Before each use or daily	<ul style="list-style-type: none">• Check the engine oil level.• Remove debris from the traction unit.• Check the tire pressure.• Grease the traction unit.• Check for loose fasteners.
Every 25 hours	<ul style="list-style-type: none">• Check the hydraulic fluid level.• Clean the foam air filter and check the paper filter for dirt or damage.• Check the hydraulic lines for leaks, loose fittings, kinked lines, loose mounting supports, wear, weather, and chemical deterioration.
Every 50 hours	<ul style="list-style-type: none">• Lubricate the traction drive chains.• Check the drive chain tension.
Every 100 hours	<ul style="list-style-type: none">• Replace the paper air filter.• Change the engine oil and filter (more frequently when operating conditions are extremely dusty or sandy).• Check the battery electrolyte level (replacement battery only).• Check the battery cable connections.• Torque the wheel lug nuts to 50 ft-lb (68 N·m).
Every 200 hours	<ul style="list-style-type: none">• Replace the carbon canister air filter. (Service more frequently if conditions are extremely dusty or sandy.)• Replace the carbon canister purge-line filter. (Service more frequently when using the vibratory plow attachment.)• Check the spark plugs.
Every 400 hours	<ul style="list-style-type: none">• Replace the hydraulic filter.
Every 1,500 hours	<ul style="list-style-type: none">• Replace all moving hydraulic hoses.
Yearly	<ul style="list-style-type: none">• Change the fuel filter.• Change the hydraulic fluid.
Yearly or before storage	<ul style="list-style-type: none">• Touch up chipped paint

Important: Refer to your *Engine Operator's Manual* for additional maintenance procedures.

⚠ CAUTION

If you leave the key in the ignition switch, someone could accidentally start the engine and seriously injure you or other bystanders.

Remove the key from the ignition and disconnect the wires from the spark plugs before you do any maintenance. Set the wires aside so that they do not accidentally contact the spark plugs.

Lubrication

Greasing the Traction Unit

Service Interval: Before each use or daily

Grease all pivot joints every 8 operating hours and immediately after every washing.

Grease Type: General-purpose grease.

1. Lower the loader arms and stop the engine. Remove the key.
2. Clean the grease fittings with a rag.
3. Connect a grease gun to each fitting (Figure 17 and Figure 18).

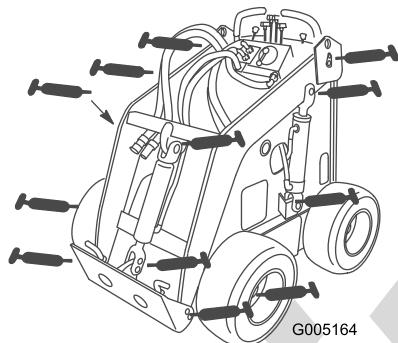

Figure 17

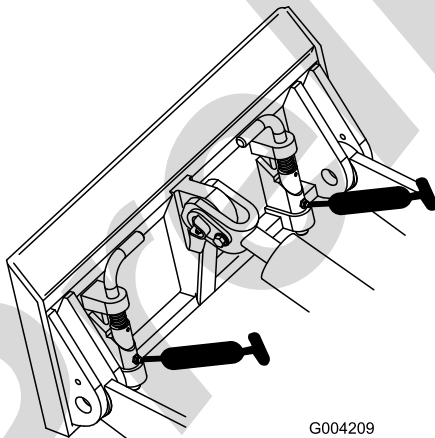

Figure 18

4. Pump grease into the fittings until grease begins to ooze out of the bearings (approximately 3 pumps).

Note: At the center of each front wheel hub is a grease fitting covered by a rubber cap. Fill these fittings with grease until the blue ring around the fitting moves all of the way out toward you, then replace the cap.

5. Wipe up any excess grease.

Engine Maintenance

Servicing the Air Cleaner

Foam Pre-filter: Clean every 25 operating hours.

Paper Filter: Check every 25 operating hours. Replace after every 100 operating hours.

Note: Service the air cleaner more frequently if operating conditions are extremely dusty or sandy.

Removing the Filters

1. Lower the loader arms, stop the engine, and remove the key.
2. Clean around the air cleaner to prevent dirt from getting into the engine and causing damage.
3. Unscrew the knob and remove the air cleaner cover (Figure 19).

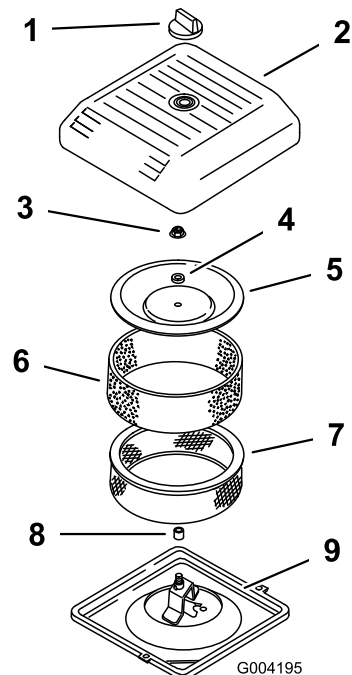

Figure 19

- | | |
|----------------------|---------------------|
| 1. Knob | 6. Foam pre-filter |
| 2. Air cleaner cover | 7. Paper filter |
| 3. Cover nut | 8. Rubber seal |
| 4. Spacer | 9. Air cleaner base |
| 5. Cover | |

4. Carefully slide the foam pre-filter off of the paper element (Figure 19).
5. Unscrew the cover nut and remove the cover, spacer and paper filter (Figure 19).

Cleaning/Replacing the Filters

Service Interval: Every 25 hours

Every 100 hours

Important: Replace the foam element if it is torn or worn.

1. Wash the foam pre-filter in liquid soap and warm water. When clean, rinse it thoroughly.
2. Dry the pre-filter by squeezing it in a clean cloth (do not wring).
3. Put one or two ounces of oil on the pre-filter (Figure 20).

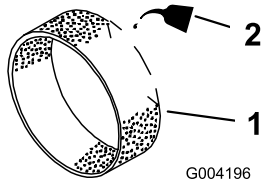

Figure 20

1. Foam element
2. Oil

4. Squeeze the pre-filter to distribute the oil.
5. Lightly tap the paper filter on a flat surface to remove dust and dirt (Figure 21).

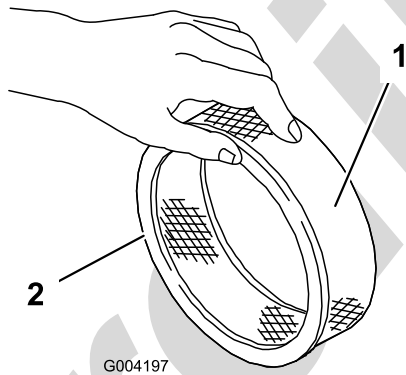

Figure 21

1. Paper element
2. Rubber seal

6. Inspect the paper filter for dirt, tears, an oily film, and damage to the rubber seal.

Important: Never clean the paper element. Replace the paper element if it is dirty or damaged.

Installing the Filters

Important: To prevent engine damage, always operate the engine with the complete foam and paper air cleaner assembly installed.

1. Carefully slide the foam pre-filter onto the paper filter (Figure 21).
2. Place the air cleaner assembly onto the air cleaner base (Figure 19).

3. Install the cover, spacer and secure it with the cover nut (Figure 19). Torque the nut to 95 inch-lb (11 N·m).
4. Install the air cleaner cover and secure it with the knob (Figure 19).

Servicing the Carbon Canister

Replacing the Carbon Canister Air Filter

Service Interval: Every 200 hours (Service more frequently if conditions are extremely dusty or sandy.)

1. Lower the loader arms, stop the engine, and remove the key.
2. Loosen the hose clamp above the carbon canister air filter (Figure 22).

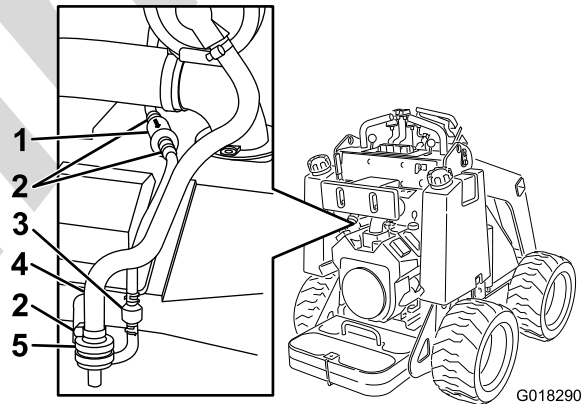

Figure 22

1. Purge-line filter
2. Hose clamp
3. Check valve
4. Hose to carbon canister
5. Air filter

3. Remove and discard the air filter (Figure 22).

Important: If a small tube section comes out of the larger hose on the barb of the filter, remove it from the filter and insert it back into the hose.

4. Install a new filter into the hose and secure it with the hose clamp (Figure 22).

Replacing the Carbon Canister Purge-line Filter

Service Interval: Every 200 hours (Service more frequently when using the vibratory plow attachment.)

Note: Check the purge-line filter occasionally for dirt. If the filter appears to be dirty, replace it.

1. Lower the loader arms, stop the engine, and remove the key.
2. Move the spring-type hose clamps on both sides of the carbon canister purge-line filter away from the filter (Figure 22).

3. Remove and discard the carbon filter (Figure 22).
4. Install a new filter into the hose with the arrow on the filter pointing towards the check valve and secure it with the hose clamps (Figure 22).

4. Place one end of a hose on the drain valve and the other end in a pan (Figure 24).

Servicing the Engine Oil

Change oil and filter after the first 50 operating hours and then every 100 operating hours thereafter.

Note: Change oil more frequently when operating conditions are extremely dusty or sandy.

Oil Type: Detergent oil (API service SG, SH, SJ, or higher)

Crankcase Capacity: w/filter, 67 oz (2 l)

Viscosity: See table below

USE THESE SAE VISCOSITY OILS

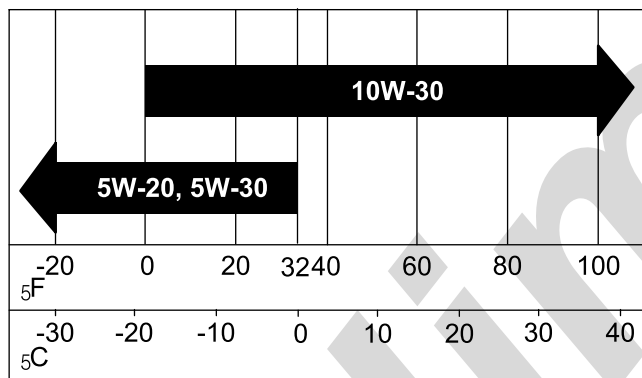

Figure 23

Changing the Oil and Filter

Service Interval: After the first 50 hours

Every 100 hours

1. Start the engine and let it run for five minutes. This warms the oil so it drains better.
2. Park the traction unit so that the drain side is slightly lower than the opposite side to ensure that the oil drains completely.
3. Lower the loader arms, chock the wheels, stop the engine, and remove the key.

CAUTION

Components will be hot if the traction unit has been running. If you touch hot components you may be burned.

Allow the traction unit to cool before performing maintenance or touching components under the hood.

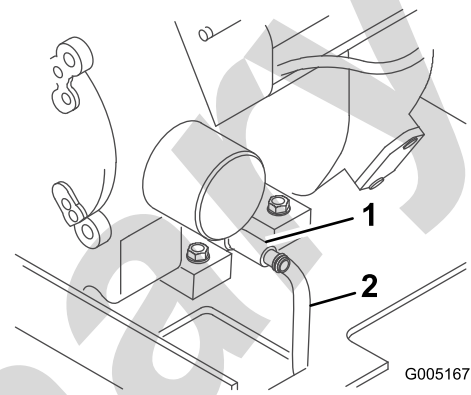

Figure 24

1. Oil drain valve

5. Open the drain valve by turning it counterclockwise, pulling out as you turn it (Figure 24).
6. When the oil has drained completely, close the drain valve and remove the hose.

Note: Dispose of the used oil at a certified recycling center.

7. Remove the old filter and wipe the filter adapter (Figure 25) gasket surface.

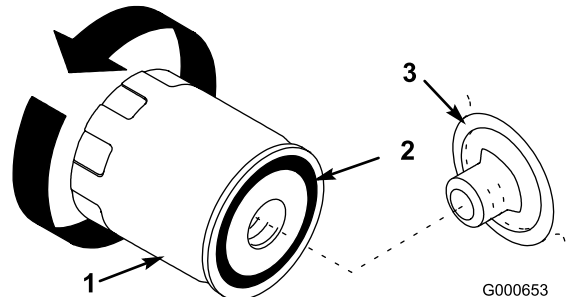

Figure 25

1. Oil filter
2. Gasket
3. Adapter

8. Pour new oil of the proper type in through the center hole of the filter. Stop pouring when the oil reaches the bottom of the threads.
9. Allow a minute or two for the oil to be absorbed by filter material, then pour off the excess oil.
10. Apply a thin coat of new oil to the rubber gasket on the replacement filter (Figure 25).
11. Install the replacement oil filter to the filter adapter. Turn the oil filter clockwise until the rubber gasket contacts the filter adapter, then tighten the filter an additional 1/2 turn (Figure 25).
12. Remove the oil fill cap and slowly pour approximately 80% of the specified amount of oil in through the valve cover.

13. Check the oil level; refer to Checking the Engine Oil Level (page 16).
14. Slowly add additional oil to bring the level to the F (full) mark on the dipstick.
15. Replace the fill cap.

Servicing the Spark Plugs

Check the spark plugs after every 200 operating hours. Ensure that the air gap between the center and side electrodes is correct before installing each spark plug. Use a spark plug wrench for removing and installing the spark plugs and a gapping tool/feeler gauge to check and adjust the air gap. Install new spark plugs if necessary.

Type: Champion Premium Gold 2071, RC12YC, or equivalent. Air Gap: 0.030 inch (0.76 mm)

Removing the Spark Plugs

1. Lower the loader arms, stop the engine, and remove the key.
2. Pull the wires off of the spark plugs (Figure 26).

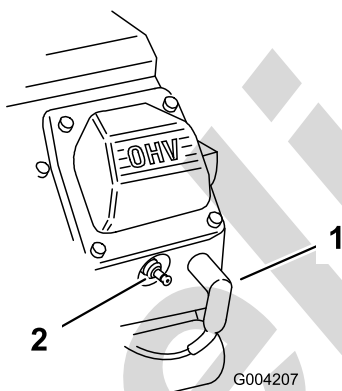

Figure 26

1. Spark plug wire
2. Spark plug

3. Clean around the spark plugs.
4. Remove both spark plugs and metal washers.

Checking the Spark Plugs

Service Interval: Every 200 hours

1. Look at the center of both spark plugs (Figure 27). If you see light brown or gray on the insulator, the engine is operating properly. A black coating on the insulator usually means the air cleaner is dirty.

Important: Never clean the spark plugs. Always replace the spark plugs when they have a black coating, worn electrodes, an oily film, or cracks.

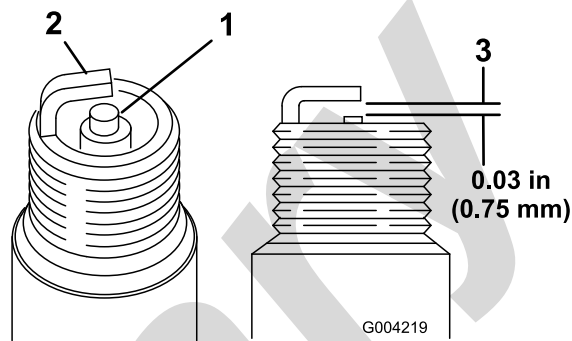

Figure 27

1. Center electrode insulator
2. Side electrode
3. Air gap (not to scale)

2. Check the gap between the center and side electrodes (Figure 27).
3. Bend the side electrode (Figure 27) if the gap is not correct.

Installing the Spark Plugs

1. Thread the spark plugs into the spark plug holes.
2. Tighten the spark plugs to 20 ft-lb (27 N·m).
3. Push the wires onto the spark plugs (Figure 26).

Fuel System Maintenance

Changing the Fuel Filter

Service Interval: Yearly

Replace the fuel filter yearly.

Important: Never install a dirty filter.

1. Lower the loader arms, stop the engine, and remove the key.
2. Shut off the fuel valve on the bottom of the fuel tank (Figure 29).
3. Clamp the fuel line between the fuel tank and the fuel filter to block the fuel flow.
4. Squeeze the ends of the hose clamps together and slide them away from the filter (Figure 28).

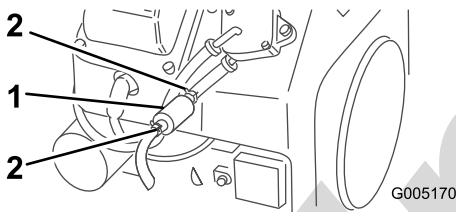

Figure 28

1. Filter
2. Hose clamp

5. Place a drain pan under the fuel lines to catch any leaks, then remove the filter from the fuel lines (Figure 28).
6. Install a new filter and move the hose clamps close to the filter.
7. Remove the clamp blocking fuel flow and open the fuel valve.

Draining the Fuel Tank

⚠ DANGER

In certain conditions, gasoline is extremely flammable and highly explosive. A fire or explosion from gasoline can burn you and others and can damage property.

- Drain gasoline from the fuel tank when the engine is cold. Do this outdoors in an open area. Wipe up any gasoline that spills.
- Never smoke when draining gasoline, and stay away from an open flame or where a spark may ignite the gasoline fumes.

1. Park the traction unit on a level surface, to ensure that the fuel tank drains completely.

2. Lower the loader arms, stop the engine, and remove the key.
3. Shut off the fuel valve in the hose near the bottom of the fuel tank (Figure 29).

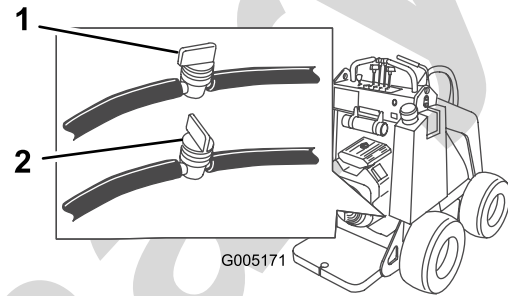

Figure 29

1. Fuel valve, open
2. Fuel valve, closed

4. Loosen the hose clamp at the fuel filter and slide it up the fuel line away from the filter.
5. Pull the fuel line off of the fuel filter, open the fuel valve, loosen the fuel tank cap, and allow the gasoline to drain into a gas can or drain pan.
6. Install the fuel line onto the fuel filter.
7. Slide the hose clamp close to the fuel filter to secure the fuel line.
8. Open the fuel valve in the hose near the bottom of the fuel tank as illustrated in Figure 29.

Note: Now is the best time to install a new fuel filter because the fuel tank is empty.

Electrical System Maintenance

WARNING

CALIFORNIA Proposition 65 Warning

Battery posts, terminals, and related accessories contain lead and lead compounds, chemicals known to the State of California to cause cancer and reproductive harm. Wash hands after handling.

Replacing the Battery

When the battery no longer holds a charge, replace it.

Important: Use only a genuine Toro replacement battery.

1. Park the traction unit on a level surface, raise the loader arms, and install the cylinder locks.
2. Stop the engine and remove the key.
3. Remove the wing nut and bolt securing the battery clamp and strip (under the clamp) and remove the clamp and strip (Figure 30).

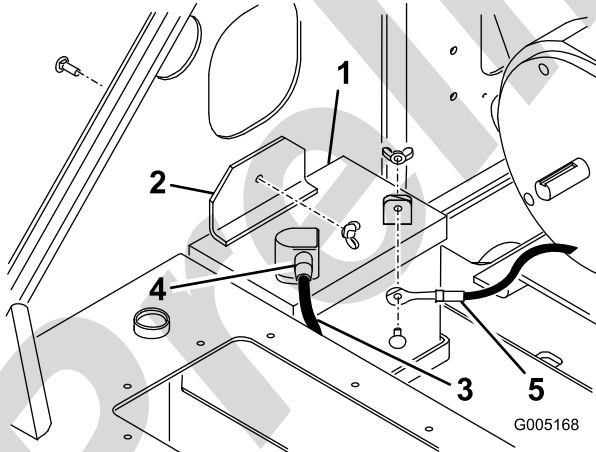

Figure 30

- | | |
|-------------------|-------------------|
| 1. Battery | 4. Rubber cover |
| 2. Battery clamp | 5. Negative cable |
| 3. Positive cable | |

⚠ WARNING

Battery terminals or metal tools could short against metal components, causing sparks. Sparks can cause the battery gasses to explode, resulting in personal injury.

- When removing or installing the battery, do not allow the battery terminals to touch any metal parts of the traction unit.
 - Do not allow metal tools to short between the battery terminals and metal parts of the traction unit.
4. Disconnect the negative (black) battery cable from the battery, saving the bolt and nut.
 5. Disconnect the positive (red) battery cable from the battery, saving the bolt and nut.
 6. Gently push the hydraulic hoses aside and lift the battery out of the chassis.
 7. Activate the new battery as directed on the battery labeling.
 8. Install the battery into the chassis (Figure 30).
 9. Secure the battery in the chassis (Figure 30).
 10. Using the bolt and wing nut supplied with the battery, connect the positive (red) cable to the positive (+) battery post (Figure 30). Slide the rubber cover over the battery post.

⚠ WARNING

Incorrect battery cable routing could damage the traction unit and cables, causing sparks. Sparks can cause the battery gasses to explode, resulting in personal injury.

- Always *disconnect* the negative (black) battery cable before disconnecting the positive (red) cable.
 - Always *connect* the positive (red) battery cable before connecting the negative (black) cable.
11. Using the bolt and wing nut supplied with the battery, connect the negative (black) cable to the negative (-) battery post (Figure 30).

Note: Ensure that the battery cables do not contact any sharp edges or each other.

Servicing the Battery

Important: The following procedures apply when servicing a (dry) battery that has replaced the original battery. The original (wet) battery does not require service.

Check the electrolyte level in the battery every 100 hours. Always keep the battery clean and fully charged. Use a paper towel to clean the battery case. If the battery terminals are corroded, clean them with a solution of four parts water and one part baking soda. Apply a light coating of grease to the battery terminals to reduce corrosion.

Voltage: 12 v, 450 Cold Cranking Amps

Checking the Electrolyte Level

Service Interval: Every 100 hours

Every 100 hours

1. Stop the engine and remove the key.
2. Remove the 4 bolts securing the battery cover and remove it from over the battery.
3. Look at the side of the battery. The electrolyte must be up to the Upper line (Figure 31). Do not allow the electrolyte to fall below the Lower line (Figure 31).

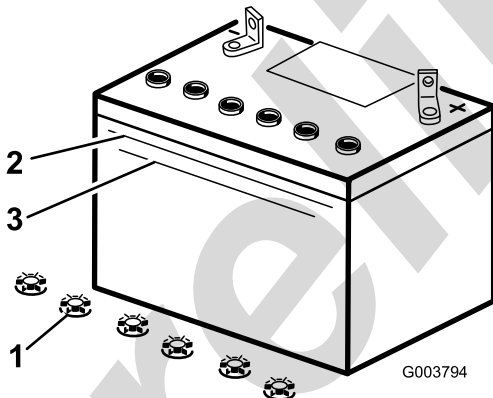

Figure 31

1. Filler caps
2. Upper line
3. Lower line

4. If the electrolyte is low, add the required amount of distilled water; refer to Adding Water to the Battery (page 28).

Adding Water to the Battery

The best time to add distilled water to the battery is just before you operate the traction unit. This lets the water mix thoroughly with the electrolyte solution.

⚠ DANGER

Battery electrolyte contains sulfuric acid which is a deadly poison and causes severe burns.

- Do not drink electrolyte and avoid contact with skin, eyes or clothing. Wear safety glasses to shield your eyes and rubber gloves to protect your hands.
- Fill the battery where clean water is always available for flushing the skin.

1. Remove the battery from the traction unit.

Important: Never fill the battery with distilled water while the battery is installed in the traction unit. Electrolyte could be spilled on other parts and cause corrosion.

2. Clean the top of the battery with a paper towel.
3. Remove the filler caps from the battery (Figure 31).
4. Slowly pour distilled water into each battery cell until the electrolyte level is up to the Upper line (Figure 31) on the battery case.

Important: Do not overfill the battery because electrolyte (sulfuric acid) can cause severe corrosion and damage to the chassis.

5. Wait five to ten minutes after filling the battery cells. Add distilled water, if necessary, until the electrolyte level is up to the Upper line (Figure 31) on the battery case.
6. Install the battery filler caps.

Charging the Battery

⚠ WARNING

Charging the battery produces gasses that can explode.

Never smoke near the battery and keep sparks and flames away from battery.

Important: Always keep the battery fully charged (1.265 specific gravity). This is especially important to prevent battery damage when the temperature is below 325F (05C).

1. Check the electrolyte level; refer to Checking the Electrolyte Level (page 28).
2. Make sure the filler caps are installed in the battery.
3. Charge the battery for 10 to 15 minutes at 25 to 30 amps or 30 minutes at 4 to 6 amps (Figure 32). Do not overcharge the battery.

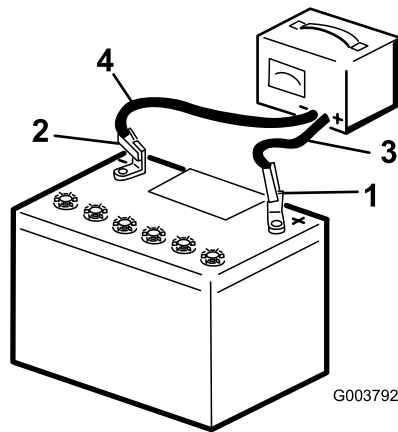

Figure 32

- | | |
|--------------------------|---------------------------|
| 1. Positive battery post | 3. Red (+) charger lead |
| 2. Negative battery post | 4. Black (-) charger lead |

4. When the battery is fully charged, unplug the charger from the electrical outlet, then disconnect the charger leads from the battery posts (Figure 32).
5. Replace the battery cover.

Drive System Maintenance

Servicing the Traction Drive Chains

Lubricating the Drive Chains

Service Interval: Every 50 hours

Lubricate the drive chain every 50 operating hours.

1. Lower the loader arms, stop the engine, and remove the key.
2. Apply a general purpose oil (10W30) onto upper and lower chain spans.
3. Start the traction unit and slowly move it forward to expose unlubed upper and lower chain spans.
4. Stop the engine and remove the key.
5. Apply oil to newly exposed unlubed chain spans.

Checking the Drive Chain Tension

Service Interval: Every 50 hours

Check the drive chain tension before using the traction unit for the first time and every 50 hours of use thereafter.

The drive chains should have about 1-1/2 to 2-1/2 inches (3.8 to 6.35 cm) of slack between the bottom of the chain guard and the bottom chain span when the top chain span is pulled tight. Use the following procedure to check the tension:

1. With the bucket installed, lower it into the ground until the front tires are off of the ground.
2. Stop the engine and remove the key.
3. Turn the front wheel forward on one side of the traction unit until the top span of the drive chain is tight.
4. Measure the distance between the bottom of the chain guard and the lower chain span (Figure 33). If the slack in the chain is not within 1-1/2 to 2-1/2 inches (3.8 to 6.35 cm), adjust the tension (refer to Adjusting the Drive Chain Tension (page 30)).

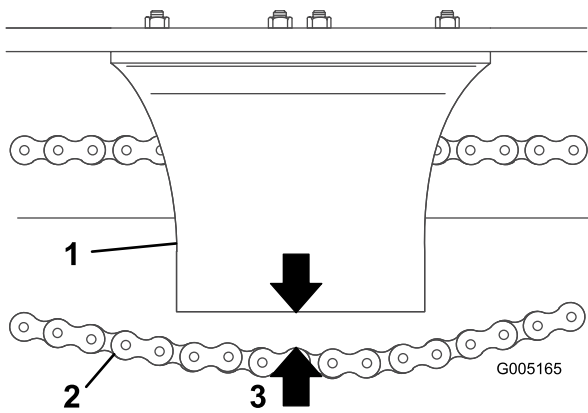

Figure 33

- | | |
|-----------------------------|--------------------------|
| 1. Chain guard | 3. 1-1/2 to 2-1/2 inches |
| 2. Bottom span of the chain | |

5. Repeat steps 3 and 4 for the other drive chain.
6. Start the engine and raise the bucket to return the front wheels to the ground.

Adjusting the Drive Chain Tension

1. With the bucket installed, lower it into the ground until the front tires are off of the ground.
2. Stop the engine and remove the key.
3. Loosen the nuts securing the axle retaining bracket (Figure 34).
4. Loosen the nut on the chain tensioning bolt and loosen the bolt (Figure 34).

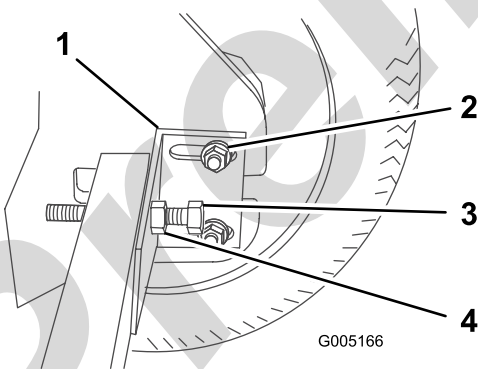

Figure 34

- | | |
|---------------------------|--------------------------|
| 1. Axle retaining bracket | 3. Chain tensioning bolt |
| 2. Nut | 4. Nut |

5. Turn the front wheel on one side of the traction unit until the upper span of the drive chain is tight.
6. Adjust the chain tensioning bolt until the distance between the bottom of the chain guard and the lower chain span is within 1-1/2 to 2-1/2 inches (3.8 to 6.35 cm) (Figure 33).
7. Position the axle retaining bracket tight against the axle and the frame, then tighten the nut on the bolt

to secure it in place (Figure 34) and torque the nut to 30 ft-lb (40.7 N·m).

8. Tighten the nuts securing the axle retaining bracket and torque them to 75 ft-lb (102 N·m).
9. Repeat steps 3 through 8 for the other drive chain.
10. Start the engine and raise the bucket to return the front wheels to the ground.

Hydraulic System Maintenance

Replacing the Hydraulic Filter

Service Interval: After the first 8 hours

Every 400 hours

Important: Do not substitute an automotive oil filter or severe hydraulic system damage may result.

Change the hydraulic filter after the first 8 operating hours and then every 400 operating hours thereafter.

1. Position traction unit on a level surface.
2. Raise the loader arms and install the cylinder locks, stop the engine, and remove the key.
3. Place a drain pan under the filter.
4. Remove the old filter (Figure 35) and wipe the surface of the filter adapter gasket clean.

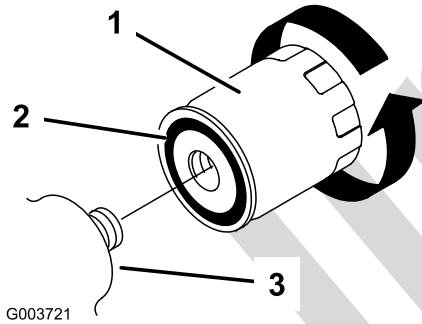

Figure 35

1. Hydraulic filter

5. Apply a thin coat hydraulic fluid to the rubber gasket on the replacement filter (Figure 35).
6. Install the replacement hydraulic filter onto the filter adapter (Figure 35). Tighten it clockwise until the rubber gasket contacts the filter adapter, then tighten the filter an additional 1/2 turn.
7. Clean up any spilled fluid.
8. Start the engine and let it run for about two minutes to purge air from the system.
9. Stop the engine and check for leaks.

⚠ WARNING

Hydraulic fluid escaping under pressure can penetrate skin and cause injury. Fluid injected into the skin must be surgically removed within a few hours by a doctor familiar with this form of injury or gangrene may result.

- Keep your body and hands away from pin hole leaks or nozzles that eject high pressure hydraulic fluid.
- Use cardboard or paper to find hydraulic leaks, never use your hands.

10. Check the fluid level in the hydraulic tank (refer to Checking the Hydraulic Fluid Level (page 16)) and add fluid to raise the level to mark on dipstick. Do not over fill the tank.
11. Remove and store the cylinder locks and lower the loader arms.

Changing the Hydraulic Fluid

Service Interval: Yearly

Hydraulic Fluid Specification:

Use only one of the following fluids in the hydraulic system:

- **Toro Premium Transmission/Hydraulic Tractor Fluid** (refer to your Authorized Toro Dealer for more information)
- **Toro Premium All Season Hydraulic Fluid** (refer to your Authorized Toro Dealer for more information)
- If neither of the above Toro fluids are available, you may use another **Universal Tractor Hydraulic Fluid (UTHF)**, but they must be only **conventional, petroleum-based** products. The specifications must fall within the listed range for all of the following material properties and the fluid should meet the listed industry standards. Check with your oil supplier to determine if the oil meets these specifications.

Note: Toro will not assume responsibility for damage caused by improper substitutions, so use only products from reputable manufacturers who will stand behind their recommendations.

Material Properties	
Viscosity, ASTM D445	cSt at 40 degrees C: 55 to 62
	cSt at 100 degrees C: 9.1 to 9.8
Viscosity index, ASTM D2270	140 to 152
Pour Point, ASTM D97	-35 to -46 degrees F (-37 to -43 degrees C)

Industry Standards

API GL-4, AGCO Powerfluid 821 XL, Ford New Holland FNHA-2-C-201.00, Kubota UDT, John Deere J20C, Vickers 35VQ25 and Volvo WB-101/BM.

Note: Many hydraulic fluids are almost colorless, making it difficult to spot leaks. A red dye additive for the hydraulic system oil is available in 2/3 oz (20 ml) bottles. One bottle is sufficient for 4-6 gal (15-22 l) of hydraulic oil. Order part no. 44-2500 from your Authorized Toro Dealer.

1. Position the traction unit on a level surface.
2. Raise the loader arms and install the cylinder locks.
3. Stop the engine and remove the key.
4. Place a large drain pan under the traction unit that can hold at least 17 US gallons (67 l).
5. Remove the drain plug from the bottom of the hydraulic tank and allow the fluid to completely drain out.
6. Install the drain plug.
7. Fill the hydraulic tank with approximately 15 US gallons (57 L) of hydraulic fluid as specified above; refer to Checking the Hydraulic Fluid Level (page 16).

Note: Dispose of used oil at a certified recycling center.

8. Remove and store the cylinder locks and lower the loader arms.

Checking the Hydraulic Lines

Service Interval: Every 25 hours

Every 1,500 hours

After every 25 operating hours, check the hydraulic lines and hoses for leaks, loose fittings, kinked lines, loose mounting supports, wear, weather, and chemical deterioration. Replace all moving hydraulic hoses every 1500 hours or 2 years, whichever comes first. Make necessary repairs before operating.

⚠ WARNING

Hydraulic fluid escaping under pressure can penetrate skin and cause injury. Fluid injected into the skin must be surgically removed within a few hours by a doctor familiar with this form of injury or gangrene may result.

- Keep your body and hands away from pin hole leaks or nozzles that eject high pressure hydraulic fluid.
- Use cardboard or paper to find hydraulic leaks, never use your hands.

Storage

1. Lower the loader arms, stop the engine, and remove the key.
2. Remove dirt and grime from the external parts of the entire traction unit, especially the engine. Clean dirt and chaff from the outside of the engine's cylinder head fins and blower housing.

Important: You can wash the traction unit with mild detergent and water. Do not pressure wash the traction unit. Avoid excessive use of water, especially near the control panel, engine, hydraulic pumps, and motors.

3. Service the air cleaner; refer to (page).
4. Grease the traction unit; refer to Greasing the Traction Unit (page 22).
5. Change the engine oil; refer to Changing the Oil and Filter (page 24).
6. Remove the spark plugs and check the condition of each; refer to Servicing the Spark Plugs (page 25).
7. With the spark plugs removed from the engine, pour two tablespoons of engine oil into each spark plug hole.
8. Place rags over the spark plug holes to catch any oil spray, then use the starter to crank the engine and distribute the oil inside the cylinder.
9. Install the spark plugs, but do not install the wires on the spark plugs.
10. Check the tire pressure; refer to Checking the Tire Pressure (page 17).
11. Charge the battery; refer to 3 Charging the Battery (page 9).
12. For storage over 30 days, prepare the traction unit as follows:
 - A. Add a petroleum based stabilizer/conditioner to fuel in the tank. Follow mixing instructions from stabilizer manufacturer (1 oz. per gallon). **Do not use an alcohol based stabilizer (ethanol or methanol).**
 - B. Run the engine to distribute conditioned fuel through the fuel system (5 minutes).
 - C. Stop the engine, allow it to cool, and drain the fuel tanks; refer to Draining the Fuel Tank.
 - D. Start the engine and run it until it stops.
 - E. Choke the engine.
 - F. Start and run the engine until it will not start again.

G. Dispose of fuel properly. Recycle as per local codes.

Important: Do not store stabilizer/conditioned gasoline over 90 days.

13. Check and tighten all bolts, nuts, and screws. Repair or replace any part that is damaged or defective.
14. Paint all scratched or bare metal surfaces. Paint is available from your Authorized Service Dealer.
15. Store the traction unit in a clean, dry garage or storage area. Remove the key from the ignition switch and keep it in a memorable place.
16. Cover the traction unit to protect it and keep it clean.

Important: When removing the traction unit from storage, charge the battery; refer to 3 Charging the Battery (page 9).

Troubleshooting

Problem	Possible Cause	Corrective Action
The starter does not crank	<ol style="list-style-type: none"> 1. The auxiliary hydraulics lever is not in the neutral position. 2. The battery is discharged. 3. The electrical connections are corroded or loose. 4. The relay or switch is damaged. 	<ol style="list-style-type: none"> 1. Move the lever to the neutral position. 2. Charge the battery or replace it. 3. Check the electrical connections for good contact. 4. Contact your Authorized Service Dealer.
The engine will not start, starts hard, or fails to keep running.	<ol style="list-style-type: none"> 1. The fuel tank is empty. 2. The choke is not on. 3. The air cleaner is dirty. 4. The spark plug wires are loose or disconnected. 5. The spark plugs are pitted, fouled, or the gap is incorrect. 6. There is dirt in the fuel filter. 7. Dirt, water, or stale fuel is in fuel system. 	<ol style="list-style-type: none"> 1. Fill the fuel tank with gasoline. 2. Move the choke lever fully forward. 3. Clean or replace the air cleaner elements. 4. Install the wires on the spark plugs. 5. Install new, correctly gapped spark plugs. 6. Replace the fuel filter. 7. Contact your Authorized Service Dealer.
The engine loses power.	<ol style="list-style-type: none"> 1. The engine load is excessive. 2. The air cleaner is dirty. 3. The oil level in crankcase is low. 4. The cooling fins and air passages under the engine blower housing are plugged. 5. The spark plugs are pitted, fouled, or the gap is incorrect. 6. There is dirt in the fuel filter. 7. Dirt, water, or stale fuel is in fuel system. 	<ol style="list-style-type: none"> 1. Reduce ground speed. 2. Clean or replace the air cleaner elements. 3. Check and add oil to the crankcase. 4. Remove any obstructions from the cooling fins and air passages. 5. Install new, correctly gapped spark plugs. 6. Replace the fuel filter. 7. Contact your Authorized Service Dealer.
The engine overheats.	<ol style="list-style-type: none"> 1. The engine load is excessive. 2. The oil level in the crankcase is low. 3. The cooling fins and air passages under the engine blower housing are plugged. 	<ol style="list-style-type: none"> 1. Reduce ground speed. 2. Check and add oil to the crankcase. 3. Remove any obstructions from the cooling fins and air passages.
Abnormal vibration.	<ol style="list-style-type: none"> 1. The engine mounting bolts are loose. 	<ol style="list-style-type: none"> 1. Tighten the engine mounting bolts.
The traction unit does not drive.	<ol style="list-style-type: none"> 1. The hydraulic fluid level low. 2. The hydraulic system is damaged. 	<ol style="list-style-type: none"> 1. Check and add hydraulic fluid. 2. Contact your Authorized Service Dealer.
When at rest, the loader arms creep downward more than 3 inches per hour (less than 3 inches an hour is normal for this traction unit).	<ol style="list-style-type: none"> 1. The valve spool is leaking 	<ol style="list-style-type: none"> 1. Contact your Authorized Service Dealer.
When at rest, loader arms settle downward 2 inches quickly and then stop.	<ol style="list-style-type: none"> 1. The cylinder seals are leaking 	<ol style="list-style-type: none"> 1. Replace the seals.

Schematics

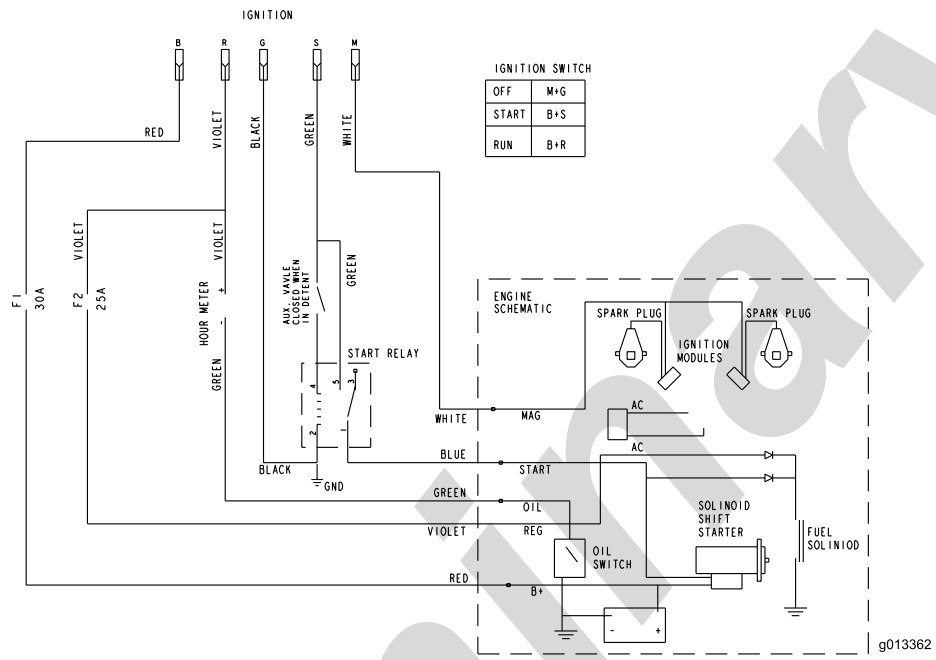

Electrical Schematic (Rev. A)

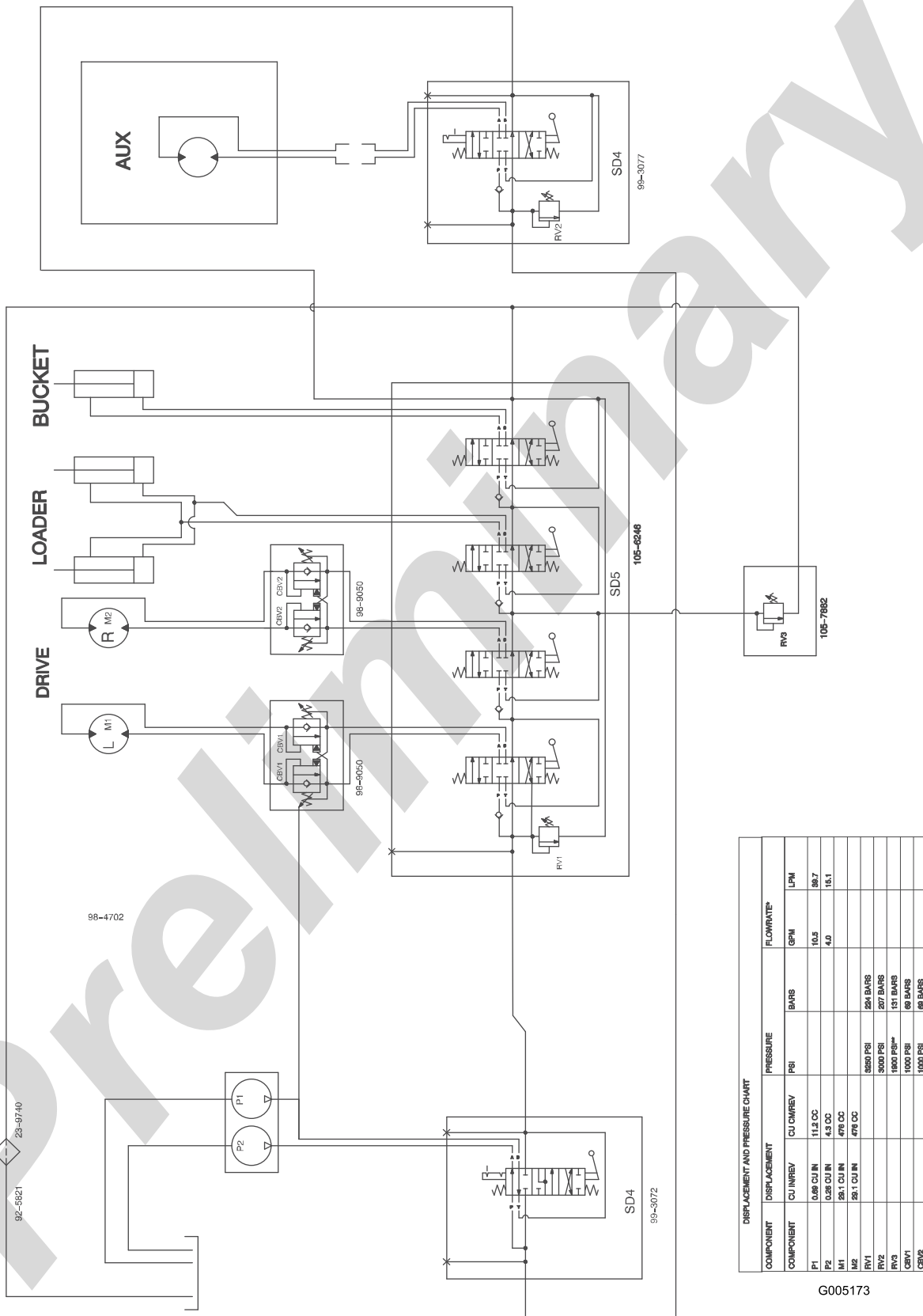

Hydraulic Schematic (Rev. A)

COMPONENT	DISPLACEMENT		PRESSURE		FLOWRATE*	
	CU IN/REV	CU OMPREV	PSI	BAR	GPM	LPM
P1	0.88 CU IN	11.2 CC			10.5	39.7
P2	0.28 CU IN	4.3 CC			4.0	15.1
M1	25.1 CU IN	476 CC				
M2	25.1 CU IN	476 CC				
RV1			3500 PSI	224 BAR		
RV2			3000 PSI	207 BAR		
RV3			1900 PSI**	131 BAR		
CBV1			1000 PSI	69 BAR		
CBV2			1000 PSI	69 BAR		

* FLOWRATE CALCULATED AT 3000 RPM AND 86% EFFICIENCY.
 ** CRACKING PRESSURE. FULL FLOW (-4 GPM) RELIEF PRESSURE APPROX. 2100 PSI

G005173

Notes:

Preliminary

Notes:

Preliminary

Notes:

Preliminary



Toro Compact Utility Equipment Warranty

A One-Year Limited Warranty

CUE Products

Conditions and Products Covered

The Toro® Company and its affiliate, Toro Warranty Company, pursuant to an agreement between them, jointly warrant your Toro Compact Utility Equipment ("Product") to be free from defects in materials or workmanship. The following time periods apply from the date of purchase:

Products	Warranty Period
Loaders, Trenchers, Stump Grinders, Chippers, Log Splitters and Attachments Kohler Engines	1 year or 1000 operating hours, whichever occurs first
Kohler Engines	3 years
All other Engines	2 years

Where a warrantable condition exists, we will repair the Product at no cost to you including diagnosis, labor, and parts.

Instructions for Obtaining Warranty Service

If you think that your Toro Product contains a defect in materials or workmanship, follow this procedure:

1. Contact any Authorized Toro Compact Utility Equipment (CUE) Service Dealer to arrange service at their dealership. To locate a dealer convenient to you, access our website at www.Toro.com. You may also call our Toro Customer Care Department toll free at 888-865-5676 (U.S. customers) or 888-865-5691 (Canadian customers).
2. Bring the product and your proof of purchase (sales receipt) to the Service Dealer.
3. If for any reason you are dissatisfied with the Service Dealer's analysis or with the assistance provided, contact us at:

LCB Customer Care Department
Toro Warranty Company
8111 Lyndale Avenue South
Bloomington, MN 55420-1196
Toll Free: 888-865-5676 (U.S. customers)
Toll Free: 888-865-5691 (Canada customers)

Owner Responsibilities

You must maintain your Toro Product by following the maintenance procedures described in the *Operator's Manual*. Such routine maintenance, whether performed by a dealer or by you, is at your expense. Parts scheduled for replacement as required maintenance ("Maintenance Parts"), are warranted for the period of time up to the scheduled replacement time for that part. Failure to perform required maintenance and adjustments can be grounds for disallowing a warranty claim.

Items and Conditions Not Covered

Not all product failures or malfunctions that occur during the warranty period are defects in materials or workmanship. This express warranty does not cover the following:

- Product failures which result from the use of non-Toro replacement parts, or from installation and use of add-on, modified, or unapproved accessories
- Product failures which result from failure to perform required maintenance and/or adjustments
- Product failures which result from operating the Product in an abusive, negligent or reckless manner
- Parts subject to consumption through use unless found to be defective. Examples of parts which are consumed, or used up, during normal Product operation include, but are not limited to, teeth, tines, blades, spark plugs, tires, tracks, filters, chains, etc.
- Failures caused by outside influence. Items considered to be outside influence include, but are not limited to, weather, storage practices, contamination, use of unapproved coolants, lubricants, additives, or chemicals, etc.
- Normal "wear and tear" items. Normal "wear and tear" includes, but is not limited to, worn painted surfaces, scratched decals or windows, etc.
- Any component covered by a separate manufacturer's warranty
- Pickup and delivery charges

General Conditions

Repair by an Authorized Toro Compact Utility Equipment (CUE) Service Dealer is your sole remedy under this warranty.

Neither The Toro® Company nor Toro Warranty Company is liable for indirect, incidental or consequential damages in connection with the use of the Toro Products covered by this warranty, including any cost or expense of providing substitute equipment or service during reasonable periods of malfunction or non-use pending completion of repairs under this warranty. All implied warranties of merchantability and fitness for use are limited to the duration of this express warranty. Some states do not allow exclusions of incidental or consequential damages, or limitations on how long an implied warranty lasts, so the above exclusions and limitations may not apply to you.

This warranty gives you specific legal rights, and you may also have other rights which vary from state to state.

Except for the engine warranty coverage and the Emissions warranty referenced below, if applicable, there is no other express warranty. The Emissions Control System on your Product may be covered by a separate warranty meeting requirements established by the U.S. Environmental Protection Agency (EPA) or the California Air Resources Board (CARB). The hour limitations set forth above do not apply to the Emissions Control System Warranty. Refer to the California Emission Control Warranty Statement supplied with your Product or contained in the engine manufacturer's documentation for details.

Countries Other than the United States or Canada

Customers who have purchased Toro products exported from the United States or Canada should contact their Toro Distributor (Dealer) to obtain guarantee policies for your country, province, or state. If for any reason you are dissatisfied with your Distributor's service or have difficulty obtaining guarantee information, contact the Toro importer. If all other remedies fail, you may contact us at Toro Warranty Company.