



TimeCutter® Riding Mowers

Model No. All models

Setup Instructions

Setup

Loose Parts

Use the chart below to verify that all parts have been shipped.

Procedure	Description	Qty.	Use
1	No parts required	–	Connect the battery.
2	No parts required	–	Set up the motion control levers.
3	No parts required	–	Connect the seat hold bar.
4	No parts required	–	Check the mower adjustment.
5	Ignition Key Hose coupling (not included in CE models) Operator's Manual Engine Operator's Manual Operator Training Material	1 1 1 1 1	Complete the Setup.

Note: Determine the left and right sides of the machine from the normal operating position.

1

Connecting the Battery

No Parts Required

Procedure

1. Locate the battery and negative battery cable. Remove the plastic cap from the negative battery post.
2. Remove the fasteners on the negative battery cable and use them to secure the negative battery cable to the negative battery post (Figure 1).

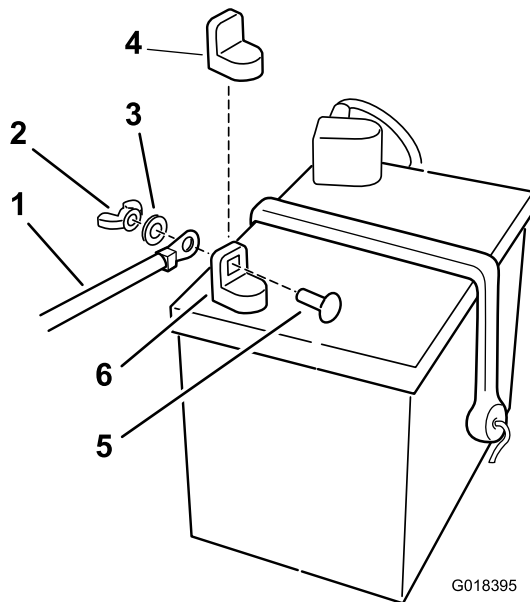

Figure 1

- | | |
|---------------------------|------------------------------|
| 1. Negative battery cable | 4. Negative battery post cap |
| 2. Wing nut | 5. Carriage bolt |
| 3. Washer | 6. Negative battery post |

2

Setting Up the Motion Control Levers

No Parts Required

Procedure

1. Locate the motion control levers attached but folded down on the machine.

2. Remove the upper bolt (3/8 x 1 inch) and washer; loosen the lower bolt (3/8 x 1 inch). Raise the motion control levers to the upright position.
3. Align the holes in the motion control lever with the holes in the control arm shaft and install the bolt and washer removed previously. Hand tighten all fasteners. Repeat this for both controls levers.
4. Move the motion control levers to the park position and raise the seat. Move the control levers back to the center position (neutral).
5. Verify the motion control levers are properly aligned. Adjust as necessary. Tighten all fasteners.

3

Connecting the Seat Hold Bar

No Parts Required

Procedure

1. Locate the seat hold bar on the frame of the machine. Remove the fasteners
2. Install the seat hold bar to the seat frame. Secure the bar with the washer and cotter pin removed previously (Figure 2).

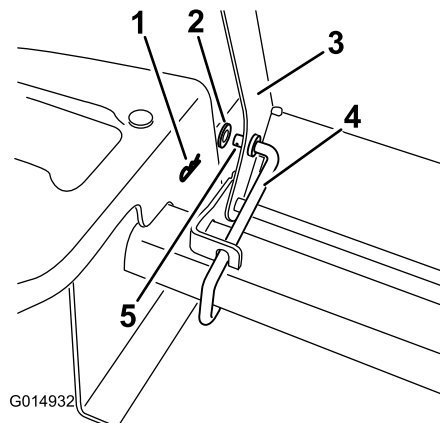

Figure 2

- | | |
|---------------|--------------------------------|
| 1. Cotter pin | 4. Seat hold bar |
| 2. Washer | 5. Hole for pin, seat hold bar |
| 3. Seat | |

4

Checking the Mower Adjustment

No Parts Required

Procedure

Adjust the side-to-side level and the front-to-rear blade slope. Use the relevant procedures in the *Operator's Manual* to verify the deck is level and make any adjustments as necessary. Refer to the *Operator's Manual* for more information.

5

Completing the Setup

Parts needed for this procedure:

1	Ignition Key
1	Hose coupling (not included in CE models)
1	<i>Operator's Manual</i>
1	<i>Engine Operator's Manual</i>
1	Operator Training Material

Procedure

Checking the Tire Pressure

Check the front and rear tires for proper inflation. Refer to Checking the Tire Pressure in the *Operator's Manual* for the recommended inflation pressure.

Checking the Side Discharge Chute

Remove the packing restraint holding the side discharge chute up and lower the chute into place.

Checking the Engine Oil Level

Before you start the engine and use the machine, check the oil level in the engine crankcase; refer to Checking the Oil Level in the *Operator's Manual*.

Keep all the following items with the machine:

- Ignition Key
- Hose coupling (not included in CE models)
- *Operator's Manual*
- *Engine Operator's Manual*
- View the Operator training material before operating the machine.



Count on it.