



GrandStand™ Mowers

Model No. All GrandStand Mowers

Setup Instructions

Loose Parts

Use the chart below to verify that all parts have been shipped.

Procedure	Description	Qty.	Use
1	No parts required	–	Check the tire pressure.
2	No parts required	–	Prepare the grass deflector.
3	No parts required	–	Check the engine oil level.
4	No parts required	–	Add fuel to the machine.
5	No parts required	–	Check the hydraulic oil level.
6	No parts required	–	Install the battery cables.
7	No parts required	–	Charge the battery.
8	No parts required	–	Check the machine before delivery to the customer.
9	Operator's Manual Engine Owner's Manual Registration Card Operator training material Key Oil drain hose	1 1 1 1 1 1	Delivering the machine to the customer.

1

Checking the Tire Pressure

No Parts Required

Procedure

Pressure: 12 to 14 psi (83 to 97 kPa)

Note: The front caster wheel is a semi-pneumatic tire and does not need to be checked.

Check the air pressure in the drive tires.

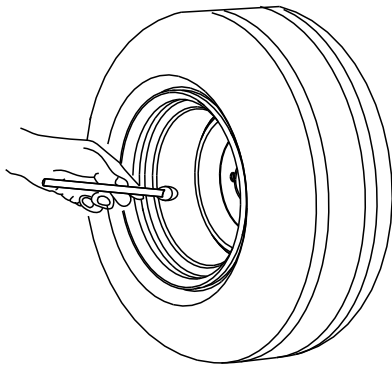

G001055

Figure 1

2

Preparing the Grass Deflector

No Parts Required

Procedure

Install the spring for the grass deflector; refer to Replacing the Grass Deflector in the *Operator's Manual*.

3

Checking the Engine Oil Level

No Parts Required

Procedure

Before you start the engine and use the machine, check the oil level in the engine crankcase; refer to Checking the Engine Oil Level in the *Operator's Manual*.

4

Adding Fuel to the Machine

No Parts Required

Procedure

Add gasoline to the machine before starting it. Refer to your *Operator's Manual* for the correct fuel and procedure. Ensure the fuel shut-off valve is open before attempting to start the engine.

5

Checking the Hydraulic Oil Level for Mowers with Hydro Drive

No Parts Required

Procedure

Before you start the engine and use the machine, check the hydraulic oil level in the tank; refer to Checking the Hydraulic Oil Level in the *Operator's Manual*.

6

Installing the Battery Cables

No Parts Required

Procedure

1. If not installed, install the positive (red) battery cable to the positive (+) battery terminal with a nut, washer and bolt. Slide the rubber cover over the post.
2. Then install the negative battery cable to the negative (-) battery terminal with a nut, washer and bolt.

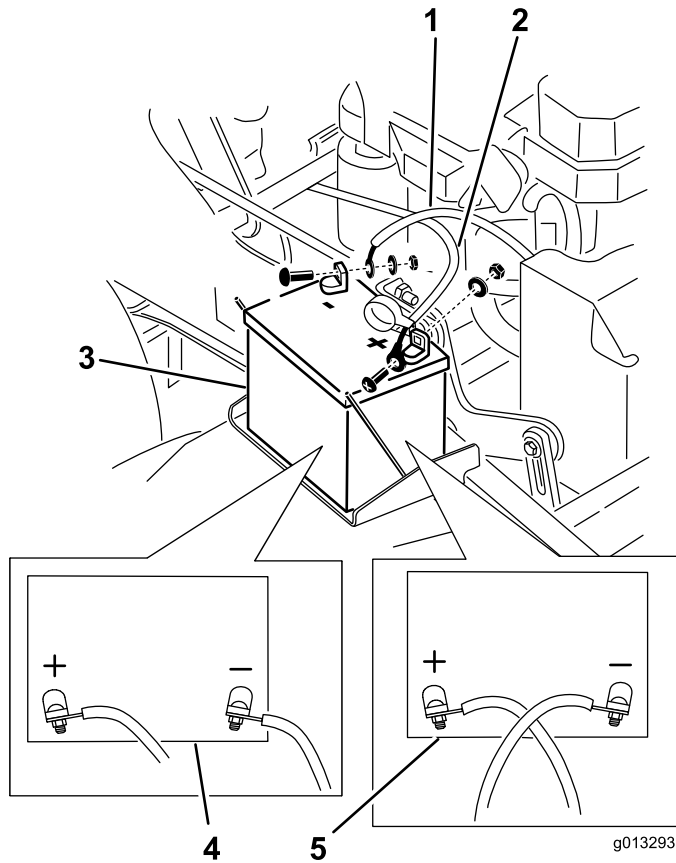

Figure 2

- | | |
|---------------------------|--|
| 1. Negative battery cable | 4. Install the battery cables like this for 48, 52 and 60 inch mowers |
| 2. Positive battery cable | 5. The battery cables cross when installed correctly for 36 and 40 inch Mowers |
| 3. Battery | |

7

Charging the Battery

No Parts Required

Procedure



Charging the battery produces gasses that can explode and cause serious injury.

- Keep cigarettes, sparks and flames away from the battery.
- Make sure the ignition switch is off.
- Ventilate when charging or using the battery in an enclosed space.

Important: Do not run the machine with the battery disconnected; electrical damage may occur to the engine.

Charge the battery. Refer to the *Operator's Manual* for instructions.

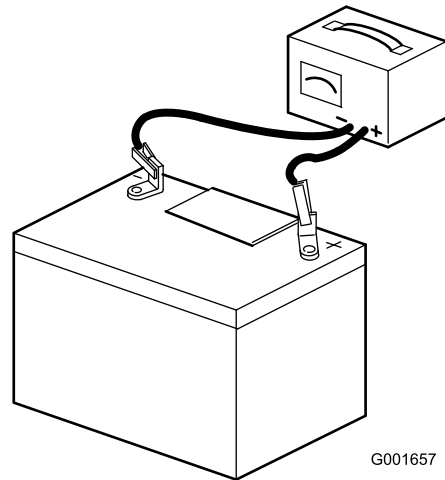

Figure 3

G001657

8

Checking the Machine Before Delivery to the Customer

No Parts Required

Procedure

Before delivering the machine to the customer, ensure that you perform or have performed the procedures listed in the following table and initial each when finished. Refer to the *Operator's Manual* for instructions on performing these procedures.

Initial	Check Procedure
	Check the tire pressure.
	Check the level of the mower.
	Check the engine oil level.
	For hydraulic driven mowers, check the hydraulic fluid level.
	Check the adjustment of the parking brake.
	Ensure that the machine tracks correctly; refer to the <i>Operator's Manual</i> for the adjustment procedure.
	Check the safety interlock system; refer to the <i>Operator's Manual</i> .
	Ensure that the PTO works.
	Check all fasteners you installed to ensure that they are tight.

When you finish setting up the machine, sign and date in the space provided below:

Signature: _____ Date: _____

9

Delivering the Machine to the Customer

Parts needed for this procedure:

1	<i>Operator's Manual</i>
1	<i>Engine Owner's Manual</i>
1	Registration Card
1	Operator training material
1	Key
1	Oil drain hose

Procedure

At delivery, Fill in the model and serial number and complete the items listed in the following table and initial each when finished.

Model No. _____ Serial No. _____

Dealer Initial	Customer Initial	Check Procedure
		Show the customer where the following features are located and how they function: <ul style="list-style-type: none"> • Fuel tank cap • Oil fill cap/Oil dipstick • Spark plug(s) • Engine oil filter • Engine oil drain • Fuel filter • Air filter • Hydraulic fluid reservoir (if applicable) • Hydraulic filter (if applicable) • Hydraulic bypass valves (if applicable) • Battery (if applicable) • Ignition switch • Throttle lever • Choke lever • Power take off switch (PTO) • Motion controls • Parking brake • Mower height-of-cut • Mower deck flow baffle
		Refer to the <i>Operator's Manual</i> to point out safety procedures, operation, and maintenance procedures.
		Review the warranty statement as shown in the <i>Operator's Manual</i> .
		Describe the post sale service procedures for your store.
		Assist the customer in filling out and mailing the registration card or register online at www.Toro.com
		Make sure that the customer receives the <i>Operator's Manual</i> , <i>Engine Owner's Manual</i> , <i>Set Up Instructions</i> , and operator training material.
		Make sure the customer knows the <i>Parts Catalog</i> is available at www.Toro.com .
		Assist the customer in loading the mower.

Note: When you, the dealer representative, have finished delivering the machine to the customer, sign and date in the space provide below and keep a copy of this page for dealer records.

Signature: _____ **Date:** _____

Signature: _____ **Date:** _____

Notes:

Notes:



Count on it.