



Excessive Play in the Steering

Product: Workman®

Jan 12, 2012

Affected Units:

Models:

Serial Numbers:

Workman® 2100	07253 & 07253TC	200000001 – 250999999
Workman® 1100	07252 & 07252TC	210000001 – 250999999
Workman® 2110	07277 & 07277TC	220000001 – 280999999
Workman® e2050	07280 & 07280TC	230000001 – 260999999
Workman® 1110	07264 & 07264TC	260000001 – 280999999
Workman® e2065	07288 & 07288TC	270000001 – 280999999
Workman® MDX	07273 & 07273TC	280000001 – 311999999
Workman® MDE	07299 & 07299TC	280000001 – 311999999
Workman® MD	07266 & 07266TC	280000001 – 310999999
Workman® MD	07279	280000001 – 311999999

Situation:

In extreme conditions (such as muddy and/or wet conditions), dirt and water can be thrown onto and enter the top of the steering box through the pitman arm shaft seal causing wear between the gears. Excessive gear wear will lead to looseness or play in the steering system.

Instructions:

When repairing or replacing the steering box, install the Cover Kit – Steering Box (120-5049) over the top of the pitman arm shaft to prevent future issues of dirt and water ingestion. Once the gearbox is installed, fill it with number 2 general purpose lithium base grease.

Each customer may install the Cover Kit – Steering Box (120-5049) at their own expense as a preventative step.

Contact your local Authorized Toro Distributor for further assistance with this or any other product issue you encounter.



Steering Box Cover Kit

Workman® MD Series Utility Vehicle

Model No. 120-5049

Form No. 3371-367 Rev A

Installation Instructions

Installing the Steering Box Cover

1. Stop the machine on a level surface, stop the engine, set the parking brake, and remove the key.
2. Open the hood.
3. Remove the passenger-side, front fender and save the fender and all fasteners.

Note: You do not need to take the outer and inner fenders apart.

4. Locate the steering box opening (Figure 1).
 - If the machine has been driven without a cover over the opening, and the area is wet or dirty, disassemble and clean the steering box thoroughly. Refer to the *Service Manual* or your Authorized Toro Distributor for assistance.
 - If the machine is new or has only been used in clean, dry conditions, clean the area around the opening (without getting water into the opening).

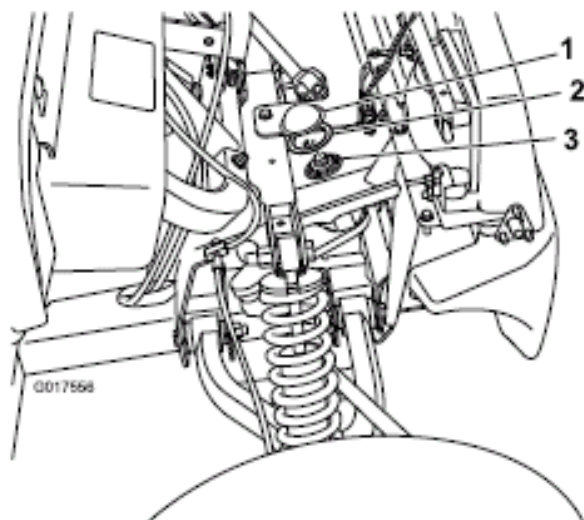

Figure 1

- | | |
|--------------------|-------------------------|
| 1. Cover | 3. Steering box opening |
| 2. Adhesive gasket | |

6. Remove the adhesive backing from the other side of the gasket and adhere the cover to the frame as shown in Figure 1.
7. Replace the fender using the fasteners you removed previously.
8. Close the hood.

5. Remove the adhesive backing from one side of the adhesive gasket and adhere the gasket to the flange on the underside of the cover (Figure 1).