



**Count on it.**

**Parts Catalog**

**60-inch Bagger Finishing Kit**

**TITAN ZX/MX Series Riding Mower**

**Model No. 121-5664**

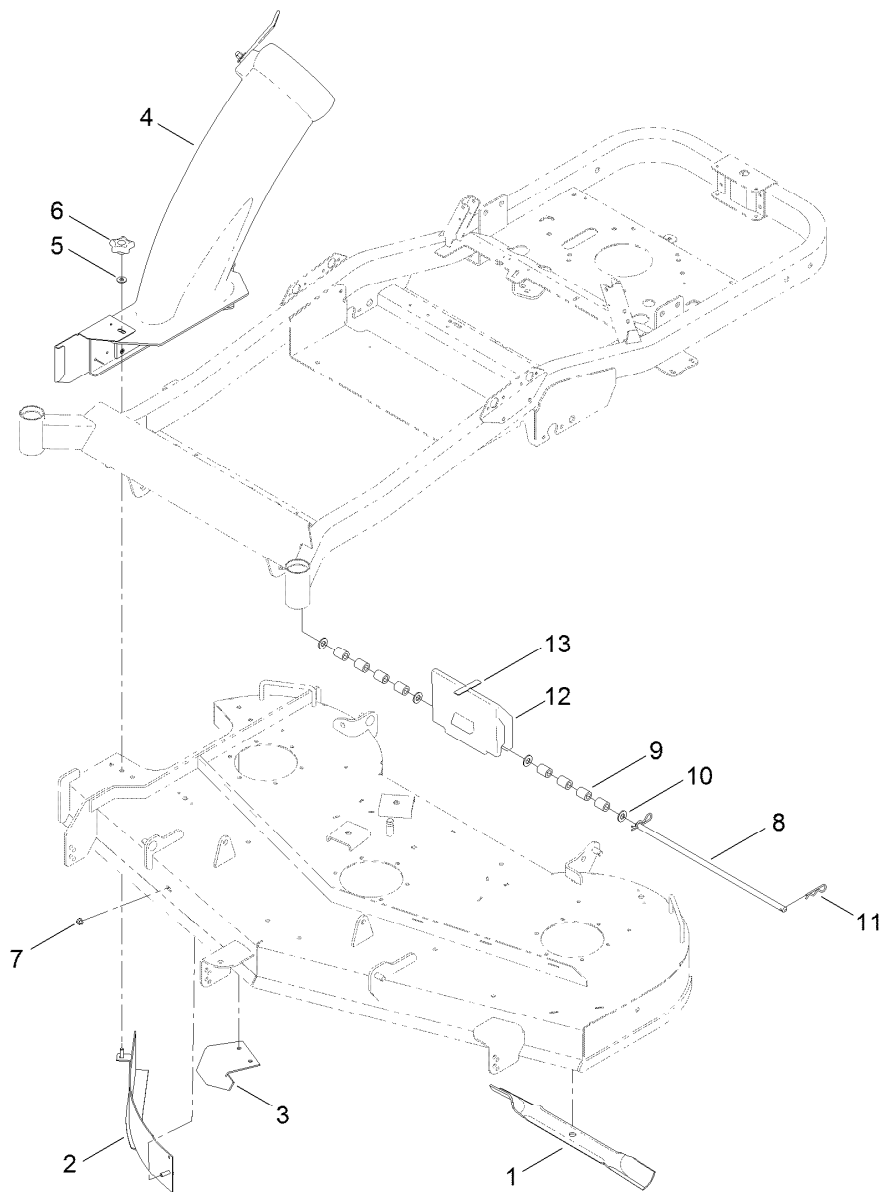

## 60 Inch Bagger Finishing Kit Assembly No. 121-5664

Ref.	Part Number	Qty.	Description
1	115-5001-03	3	Blade-20.50 Inch
2	119-3371-03	1	Baffle-Bagger
3	119-3479-03	1	Baffle-Cutoff
4	119-3457	1	Bagger Boot ASM
5	3256-3	1	Washer-Flat
6	108-8162	1	Knob-Locking
7	104-8300	1	Nut-Flange, NI
8	115-5030	1	Rod-Deck, Pivot
9	66-6501	8	Spacer-Wheel
10	3256-26	4	Washer-Flat
11	3290-355	2	Pin-Hair
12	115-9640-03	1	Weight-Bagger
13	112-4033	1	Bumper-Pad

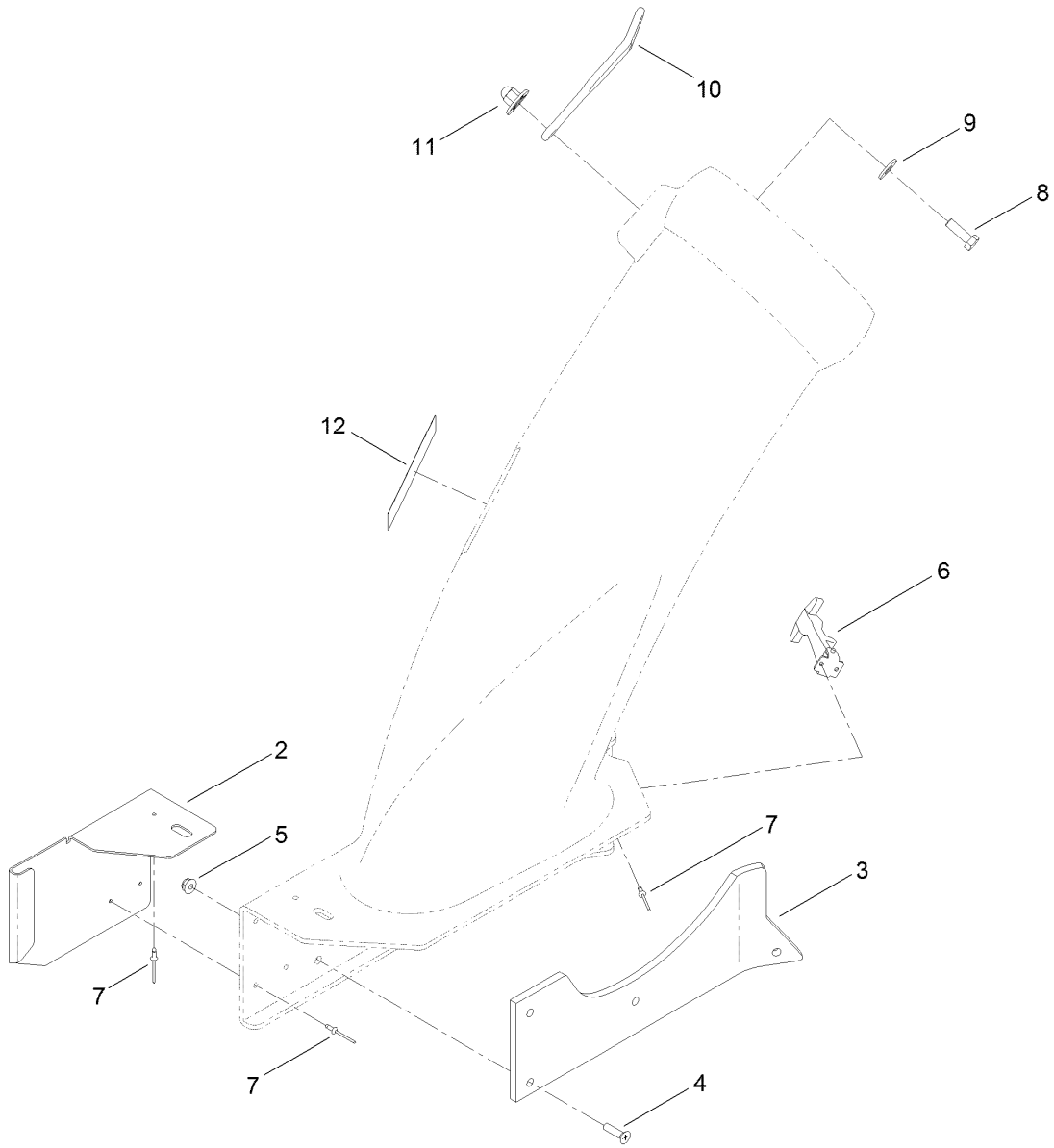

## Bagger Boot Assembly No. 119-3457

<i>Ref.</i>	<i>Part Number</i>	<i>Qty.</i>	<i>Description</i>
2	119-3374-03	1	Plate-Bagger
3	119-3478	1	Plate-Spacer
4	32108-5	4	Screw-FH
5	104-7201	4	Nut-HF
6	117344	1	Handle ASM
7	3269-31	7	Rivet-Pop
8	322-5	1	Screw-HH
9	3256-3	1	Washer-Flat
10	82-5690	1	Retainer-Duct
11	114-9015	1	Nut-Impeller
12	110-6691	1	Decal-Danger



**Count on it.**