



Count on it.

Parts Catalog

48-inch Bagger Finishing Kit

TITAN ZX/MX Series Riding Mower

Model No. 121-5662

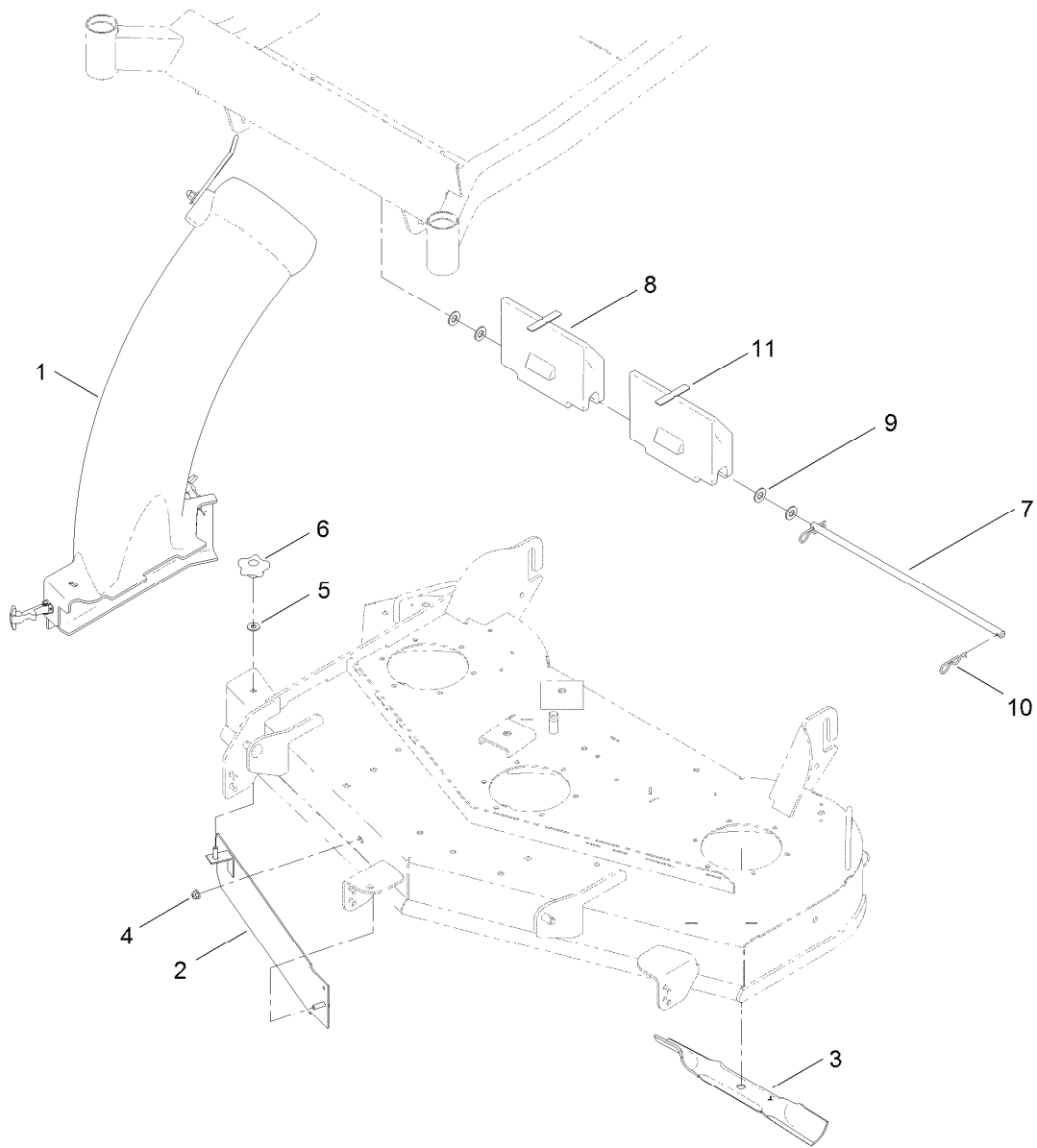

48 Inch Bagger Finishing Kit Assembly 121-5662

<i>Ref.</i>	<i>Part Number</i>	<i>Qty.</i>	<i>Description</i>
1	120-5525	1	Chute ASM
2	117-7419-03	1	Baffle ASM
3	117-7279-03	3	Blade-Hi Lift, 16.50 In
4	104-8300	1	Nut-Flange, NI
5	3256-3	1	Washer-Flat
6	108-8162	1	Knob-Locking
7	115-5030	1	Rod-Deck, Pivot
8	115-9640-03	2	Weight-Bagger
9	3256-26	4	Washer-Flat
10	3290-355	2	Pin-Hair
11	112-4033	2	Bumper-Pad

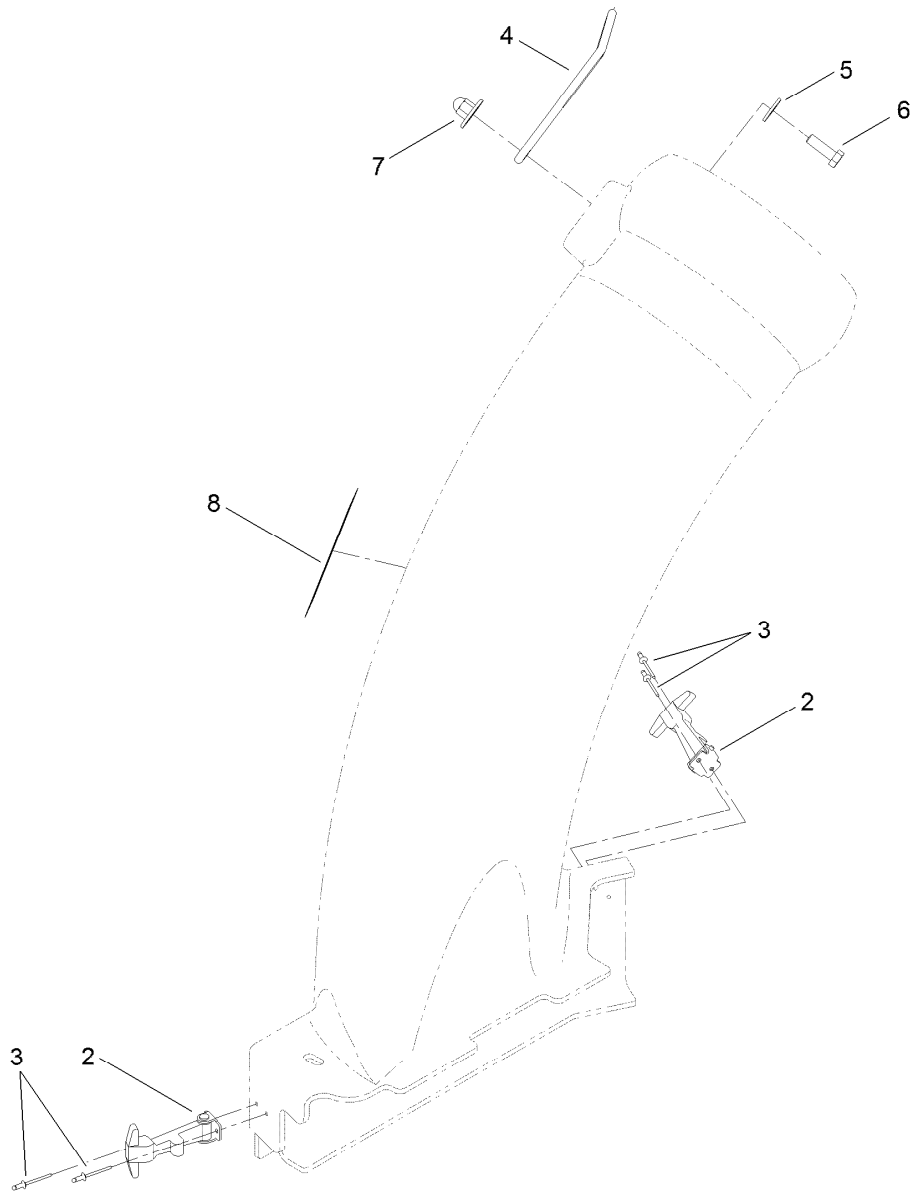

Chute Assembly No. 120-5525

<i>Ref.</i>	<i>Part Number</i>	<i>Qty.</i>	<i>Description</i>
2	117344	2	Handle ASM
3	3269-31	4	Rivet-Pop
4	82-5690	1	Retainer-Duct
5	3256-3	1	Washer-Flat
6	322-5	1	Screw-HH
7	114-9015	1	Nut-Impeller
8	110-6691	1	Decal-Danger



Count on it.