



**Count on it.**

**Operator's Manual**

**Greensmaster® 3320 TriFlex™  
Traction Unit**

Model No. 04530—Serial No. 31200001 and Up

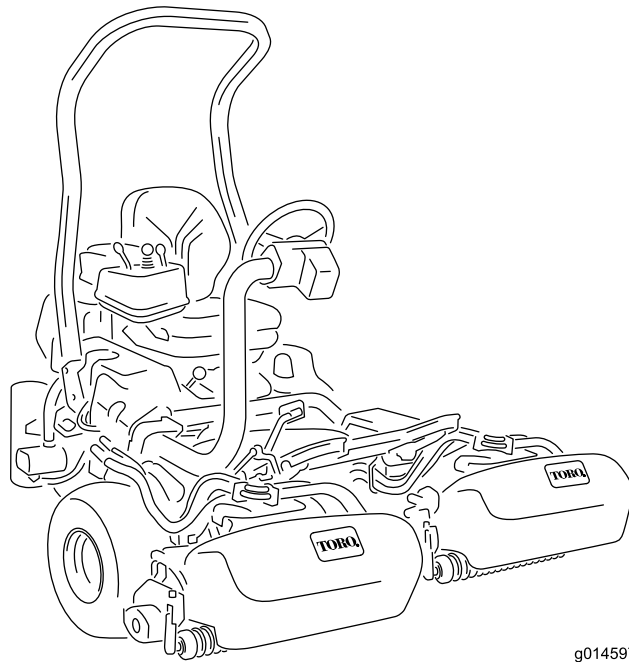

g014597

This product complies with all relevant European directives, for details please see the separate product specific Declaration of Conformity (DOC) sheet.

## WARNING

### CALIFORNIA Proposition 65 Warning

Diesel engine exhaust and some of its constituents are known to the State of California to cause cancer, birth defects, and other reproductive harm.

**Important:** This engine is not equipped with a spark arrester muffler. It is a violation of California Public Resource Code Section 4442 to use or operate the engine on any forest-covered, brush-covered, or grass-covered land. Other states or federal areas may have similar laws.

## Introduction

This machine is a ride-on, reel-blade lawnmower intended to be used by professional, hired operators in commercial applications. It is primarily designed for cutting grass on well-maintained lawns in parks, golf courses, sports fields, and on commercial grounds. It is not designed for cutting brush, mowing grass and other growth alongside highways, or for agricultural uses.

Read this information carefully to learn how to operate and maintain your product properly and to avoid injury and product damage. You are responsible for operating the product properly and safely.

You may contact Toro directly at [www.Toro.com](http://www.Toro.com) for product and accessory information, help finding a dealer, or to register your product.

Whenever you need service, genuine Toro parts, or additional information, contact an Authorized Service Dealer or Toro Customer Service and have the model and serial numbers of your product ready. Figure 1 identifies the location of the model and serial numbers on the product. Write the numbers in the space provided.

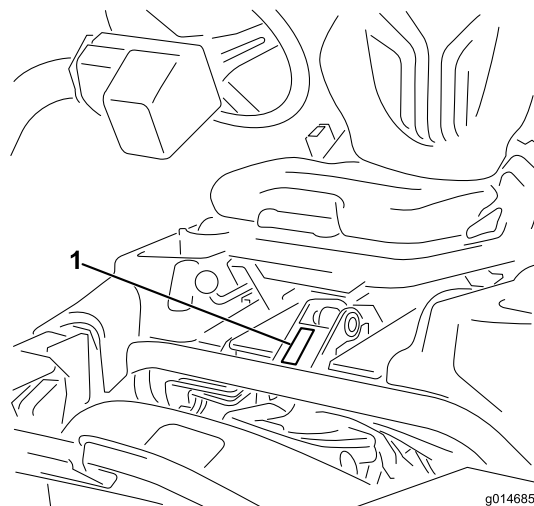

Figure 1

1. Model and serial number location

Model No. \_\_\_\_\_

Serial No. \_\_\_\_\_

This manual identifies potential hazards and has safety messages identified by the safety alert symbol (Figure 2), which signals a hazard that may cause serious injury or death if you do not follow the recommended precautions.



Figure 2

1. Safety alert symbol

This manual also uses 2 words to highlight information. **Important** calls attention to special mechanical information and **Note** emphasizes general information worthy of special attention.

# Contents

Introduction .....	2	Adjusting the Transmission for Neutral .....	38
Safety .....	4	Adjusting the Transport Speed .....	39
Safe Operating Practices .....	4	Adjusting the Mowing Speed.....	39
Toro Mower Safety .....	5	Brake Maintenance .....	40
Sound Power Level.....	6	Adjusting the Brakes .....	40
Sound Pressure Level.....	6	Hydraulic System Maintenance .....	40
Vibration Level .....	6	Changing the Hydraulic Oil and Filter.....	40
Safety and Instructional Decals .....	7	Checking the Hydraulic Lines and Hoses.....	41
Setup .....	11	Cutting Unit Maintenance .....	41
1 Installing the Roll Bar .....	12	Backlapping the Reels .....	41
2 Installing the Seat.....	12	Storage .....	42
3 Installing the Steering Wheel.....	13	Schematics .....	43
4 Activating and Charging the Battery.....	13		
5 Installing the Optional Oil Cooler.....	15		
6 Installing the Grass Basket Hooks .....	15		
7 Installing the Cutting Units .....	15		
8 Adding Rear Weight .....	17		
9 Installing EU Decals.....	17		
Product Overview .....	18		
Controls .....	18		
Specifications .....	24		
Attachments/Accessories.....	24		
Operation .....	25		
Think Safety First.....	25		
Checking the Engine Oil.....	25		
Filling the Fuel Tank .....	25		
Checking the Hydraulic Fluid Level.....	26		
Checking the Reel-to-Bedknife Contact .....	27		
Checking the Tire Pressure .....	27		
Checking the Torque of the Wheel Nuts.....	27		
Break-in Period .....	27		
Starting the Engine .....	28		
Checking the Safety Interlock System .....	28		
Installing and Removing the Cutting Units .....	29		
Training Period .....	31		
Before Mowing .....	31		
Mowing .....	31		
Transport Operation.....	32		
Inspection and Cleanup After Mowing .....	32		
Towing the Traction Unit.....	32		
Maintenance .....	33		
Recommended Maintenance Schedule(s) .....	33		
Daily Maintenance Checklist .....	34		
Lubrication .....	35		
Greasing the Machine .....	35		
Engine Maintenance .....	35		
Servicing the Air Cleaner .....	35		
Changing the Engine Oil and Filter .....	36		
Replacing the Spark Plugs .....	36		
Fuel System Maintenance .....	37		
Replacing the Fuel Filter.....	37		
Fuel Lines and Connections .....	37		
Electrical System Maintenance .....	37		
Servicing the Battery.....	37		
Servicing the Fuses .....	38		
Drive System Maintenance .....	38		

# Safety

This machine meets or exceeds CEN standard EN 836:1997, ISO standard 5395:1990, and ANSI B71.4-2004 specifications in effect at the time of production when 119 lb (54 kg) of weight is added to the rear wheel.

**Note:** The addition of attachments made by other manufacturers that do not meet American National Standards Institute certification will cause noncompliance of this machine.

**Improper use or maintenance by the operator or owner can result in injury. To reduce the potential for injury, comply with these safety instructions and always pay attention to the safety alert symbol (Figure 2), which means Caution, Warning, or Danger—personal safety instruction. Failure to comply with the instruction may result in personal injury or death.**

## Safe Operating Practices

The following instructions are from CEN standard EN 836:1997, ISO standard 5395:1990, and ANSI B71.4-2004.

### Training

- Read the *Operator's Manual* and other training material. If the operator(s) or mechanic(s) can not read the manual it is the owner's responsibility to explain this material to them.
- Become familiar with the safe operation of the equipment, operator controls, and safety signs.
- All operators and mechanics should be trained. The owner is responsible for training the users.
- Never let children or untrained people operate or service the equipment. Local regulations may restrict the age of the operator.
- The owner/user can prevent and is responsible for accidents or injuries occurring to himself or herself, other people or property.

### Preparation

- Evaluate the terrain to determine what accessories and attachments are needed to properly and safely perform the job. Only use accessories and attachments approved by the manufacturer.
- Wear appropriate clothing including substantial footwear, hard hat, safety glasses and ear protection. Long hair, loose clothing or jewelry may get tangled in moving parts.
- Inspect the area where the equipment is to be used and remove all objects such as rocks, toys and wire which can be thrown by the machine.
- Use extra care when handling gasoline and other fuels. They are flammable and vapors are explosive.
  - Use only an approved container.

- Never remove the gas cap or add fuel with engine running. Allow engine to cool before refueling.
- Never smoke when handling gasoline, and stay away from an open flame or where gasoline fumes may be ignited by a spark.
- Never refuel or drain the machine indoors.
- Check that operator's presence controls, safety switches and shields are attached and functioning properly. Do not operate unless they are functioning properly.

### Operation

- Never run an engine in an enclosed area.
- Only operate in good light, keeping away from holes and hidden hazards.
- Be sure all drives are in neutral and parking brake is engaged before starting engine. Only start engine from the operator's position. Always use seat belts with the ROPS.
- Slow down and use extra care on hillsides. Be sure to travel in the recommended direction on hillsides. Turf conditions can affect the machine's stability. Use caution while operating near drop-offs.
- Slow down and use caution when making turns and when changing directions on slopes.
- Never operate with guards not securely in place. Be sure all interlocks are attached, adjusted properly, and functioning properly.
- Do not change the engine governor setting or overspeed the engine.
- Stop on level ground, lower the cutting units, disengage drives, engage parking brake (if provided), shut off engine before leaving the operator's position for any reason including emptying the grass baskets.
- Stop equipment and inspect the machine after striking objects or if an abnormal vibration occurs. Make necessary repairs before resuming operations.
- Keep hands and feet away from the cutting units.
- Look behind and down before backing up to be sure of a clear path.
- Never carry passengers and keep pets and bystanders away.
- Slow down and use caution when making turns and crossing roads and sidewalks. Stop reels if not mowing.
- Do not operate the mower under the influence of alcohol or drugs
- Lightning can cause severe injury or death. If lightning is seen or thunder is heard in the area, do not operate the machine; seek shelter.
- Use care when loading or unloading the machine into a trailer or truck.
- Use care when approaching blind corners, shrubs, trees, or other objects that may obscure vision.

## Maintenance and Storage

- Disengage drives, lower the cutting units, set the parking brake, stop the engine, remove the key, and disconnect spark plug wire(s). Wait for all movement to stop before adjusting, cleaning, or repairing.
- Clean grass and debris from cutting units, drives, mufflers, and engine to help prevent fires. Clean up oil or fuel spillage.
- Let the engine cool before storing and do not store near flame.
- Shut off fuel while storing or transporting. Do not store fuel near flames or drain indoors.
- Park the machine on level ground.
- Never allow untrained personnel to service the machine.
- Use jack stands to support components when required.
- Carefully release pressure from components with stored energy.
- Disconnect the battery and remove the spark plug wire(s) before making any repairs. Disconnect the negative terminal first and the positive last. Reconnect positive first and negative last.
- Use care when checking the reels. Wear gloves and use caution when checking the reels.
- Keep hands and feet away from moving parts. If possible, do not make adjustments with the engine running.
- Charge batteries in an open, well ventilated area, away from spark and flames. Unplug the charger before connecting or disconnecting it from the battery. Wear protective clothing and use insulated tools.
- Keep all parts in good working condition and all hardware and hydraulic fittings tightened. Replace all worn or damaged decals.

## Toro Mower Safety

The following list contains safety information specific to Toro products or other safety information that you must know that is not included in the ANSI standards.

This product is capable of amputating hands and feet and throwing objects. Always follow all safety instructions to avoid serious injury or death.

Use of this product for purposes other than its intended use could prove dangerous to user and bystanders.

## Operation

- Know how to stop the engine quickly.
- Always wear substantial shoes. Do not operate the machine while wearing sandals, tennis shoes, or sneakers. Wearing safety shoes and long pants is advisable and required by some local ordinances and insurance regulations.
- Handle fuel carefully. Wipe up any spills.

- Check the safety interlock switches daily for proper operation. If a switch has failed, replace the switch before operating the machine.
- Before attempting to start the engine, sit on the seat, pull on the raise/lower mow control to ensure that the cutting units are disengaged, ensure that the traction pedal is in neutral, and engage the parking brake.
- Using the machine demands attention. To prevent loss of control:
  - Do not drive close to sand traps, ditches, creeks, or other hazards.
  - Reduce speed when making sharp turns. Avoid sudden stops and starts.
  - This machine is not designed or equipped for on-road use and is a “slow-moving vehicle.” If you must cross or travel on a public road, you should be aware of and comply with local regulations, such as required lights, slow moving vehicle signs, and reflectors.
  - Watch out for traffic when near or crossing roads. Always yield the right-of-way.
  - Apply the service brakes when going downhill to keep forward speed slow and to maintain control of the machine.
- Shut the engine off before emptying the baskets.
- Raise the cutting units when driving from one work area to another.
- Do not touch the engine, muffler, or exhaust pipe while the engine is running or soon after it has stopped because these areas could be hot enough to cause burns.
- Stay clear of the rotating screen at the side of the engine to prevent direct contact with your body or clothing.
- If a cutting unit strikes a solid object or vibrates abnormally, stop immediately, turn the engine off, wait for all motion to stop, and inspect the machine for damage. A damaged reel or bedknife must be repaired or replaced before operation is continued.
- Before getting off of the seat, move the functional control lever to neutral (N), raise the cutting units and wait for the reels to stop spinning. Set the parking brake. Stop the engine and remove the key from the ignition switch.
- Traverse slopes carefully. Do not start or stop suddenly when traveling uphill or downhill.
- The operator must be skilled and trained in how to drive on hillsides. Failure to use caution on slopes or hills may cause loss of control and cause the machine to tip or roll, possibly resulting in personal injury or death.
- If the engine stalls or loses headway and cannot make it to the top of a slope, do not turn the machine around. Always back slowly, straight down the slope.
- When a person or pet appears unexpectedly in or near the mowing area, **stop mowing**. Careless operation, combined with terrain angles, ricochets, or improperly positioned guards can lead to thrown object injuries. Do not resume mowing until the area is cleared.

- Whenever the machine is left unattended, make sure the cutting units are fully raised, the reels are not spinning, the key is removed from the ignition switch, and the parking brake is set.
- Always use the seat belt with the ROPS when operating the machine.
- Do not operate this machine on slopes exceeding 15 degrees.

## Maintenance and Storage

- Make sure all hydraulic line connectors are tight and all hydraulic hoses and lines are in good condition before applying pressure to the system.
- Keep your body and hands away from pin hole leaks or nozzles that eject hydraulic fluid under high pressure. Use paper or cardboard, not your hands, to search for leaks. Hydraulic fluid escaping under pressure can have sufficient force to penetrate the skin and cause serious injury.
- Before disconnecting or performing any work on the hydraulic system, all pressure in the system must be relieved by stopping the engine and lowering the cutting units and attachments to the ground.
- Check all fuel lines for tightness and wear on a regular basis. Tighten or repair them as needed.
- If the engine must be running to perform a maintenance adjustment, keep hands, feet, clothing, and any parts of the body away from the cutting units, attachments, and any moving parts, especially the screen at the side of the engine. Keep everyone away.
- Do not overspeed the engine by changing governor settings. To ensure safety and accuracy, have an Authorized Toro Distributor check the maximum engine speed with a tachometer..
- The engine must be shut off before checking the oil or adding oil to the crankcase.
- If major repairs are ever needed or if assistance is desired, contact an Authorized Toro Distributor.
- To assure optimum performance and continued safety certification of the machine, use only genuine Toro replacement parts and accessories. Replacement parts and accessories made by other manufacturers could be dangerous, and such use could void the product warranty.
- Disconnect the cutting units from the power supply, using the cutting unit power disconnect couplers, before performing any work on the cutting units.

## Sound Power Level

This unit has a guaranteed sound power level of 97 dBA, which includes an Uncertainty Value (K) of 1 dBA.

Sound power level was determined according to the procedures outlined in ISO 11094.

## Sound Pressure Level

This unit has a sound pressure level at the operator's ear of 81 dBA, which includes an Uncertainty Value (K) of 1 dBA.

Sound pressure level was determined according to the procedures outlined in EN 836.

## Vibration Level

### Hand-Arm

Measured vibration level for right hand = 0.31 m/s<sup>2</sup>

Measured vibration level for left hand = 0.20 m/s<sup>2</sup>

Uncertainty Value (K) = 0.15 m/s<sup>2</sup>

Measured values were determined according to the procedures outlined in EN 836.

### Whole Body

Measured vibration level = 0.14 m/s<sup>2</sup>

Uncertainty Value (K) = 0.07 m/s<sup>2</sup>

Measured values were determined according to the procedures outlined in EN 836.

# Safety and Instructional Decals



Safety decals and instructions are easily visible to the operator and are located near any area of potential danger. Replace any decal that is damaged or lost.

GREENSMATER 3XXX							
1	2		3		4		5
	3.8 MPH 6.1 Km/h	5.0 MPH 8.0 Km/h	3.8 MPH 6.1 Km/h	5.0 MPH 8.0 Km/h	3.8 MPH 6.1 Km/h	5.0 MPH 8.0 Km/h	3.8 MPH 6.1 Km/h
0.062" / 1.6mm	N/R	N/R	9	N/R	9	N/R	9
0.094" / 2.4mm	N/R	N/R	9	N/R	9	N/R	9
0.125" / 3.2mm	N/R	N/R	9	N/R	9	N/R	9
0.156" / 4.0mm	N/R	N/R	9	N/R	9	N/R	N/R
0.188" / 4.8mm	N/R	N/R	9	N/R	7	N/R	N/R
0.218" / 5.5mm	N/R	N/R	9	N/R	6	N/R	N/R
0.250" / 6.4mm	7	N/R	6	7	5	7	N/R
0.312" / 7.9mm	6	N/R	5	6	4	6	N/R
0.375" / 9.5mm	6	7	4	5	4	5	N/R
0.438" / 11.1mm	6	6	4	5	3	4	N/R
0.500" / 12.7mm	5	6	3	4	N/R	N/R	N/R
0.625" / 15.9mm	4	5	3	3	N/R	N/R	N/R
0.750" / 19.0mm	3	4	3	3	N/R	N/R	N/R
0.875" / 22.2mm	3	4	N/R	3	N/R	N/R	N/R
1.000" / 25.4mm	3	3	N/R	N/R	N/R	N/R	N/R

115-8156

- |                         |                          |                          |         |
|-------------------------|--------------------------|--------------------------|---------|
| 1. Reel height          | 3. 8 Blade cutting unit  | 5. 14 Blade cutting unit | 7. Fast |
| 2. 5 Blade cutting unit | 4. 11 Blade cutting unit | 6. Reel speed            | 8. Slow |

115-8200		1	
HYDRAULIC FAN KIT	LIFT REEL E-REEL ENABLE	15A	7.5A
	REEL ENGAGE LIFT/LOWER		7.5A
LIGHTS LEAK DETECTOR	START/RUN DIAG. LIGHT LEAK DETECTOR	15A	7.5A
RUN	ECM LOGIC POWER	10A	2A

115-8200

1. Read the *Operator's manual* for fuse information.

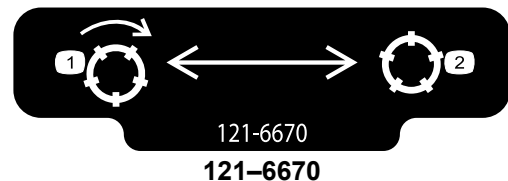

1. Engage the reels.      2. Disengage the reels.

**CALIFORNIA SPARK ARRESTER WARNING**  
 Operation of this equipment may create sparks that can start fires around dry vegetation. A spark arrester may be required. The operator should contact local fire agencies for laws or regulations relating to fire prevention requirements. 117-2718

117-2718  
 Model 74845 only

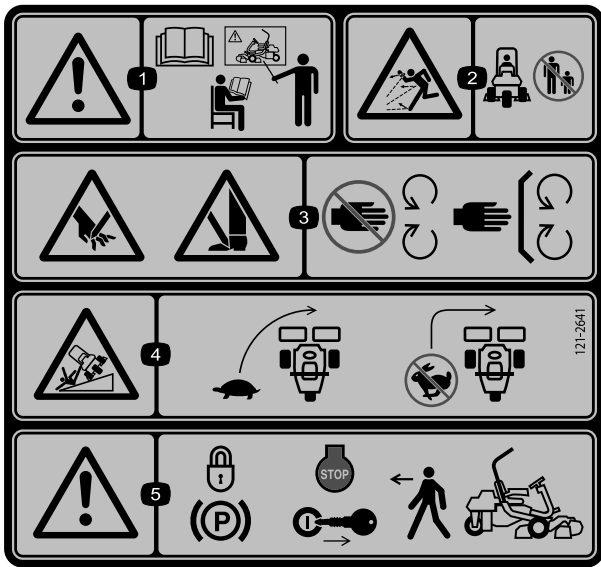

121-2641

1. Warning—read the *Operator's Manual*, do not operate this machine unless you are trained.
2. Thrown object hazard—keep bystanders a safe distance from the machine.
3. Cutting/dismemberment hazard of hand or foot, mower blade—stay away from moving parts; keep all guards and shields in place.
4. Tipping hazard—slow machine before turning, do not turn at high speeds.
5. Warning—lock the parking brake, stop the engine and remove the ignition key before leaving the machine.

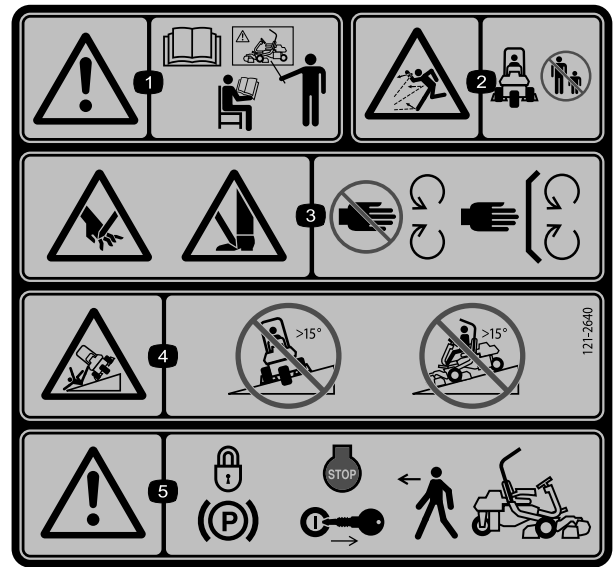

121-2640

1. Warning—read the *Operator's Manual*, do not operate this machine unless you are trained.
2. Thrown object hazard—keep bystanders a safe distance from the machine
3. Cutting/dismemberment hazard of hand or foot, mower blade—stay away from moving parts; keep all guards and shields in place.
4. Tipping hazard—do not drive across slopes greater than 15 degrees or down slopes greater than 15 degrees.
5. Warning—lock the parking brake, stop the engine and remove the ignition key before leaving the machine.



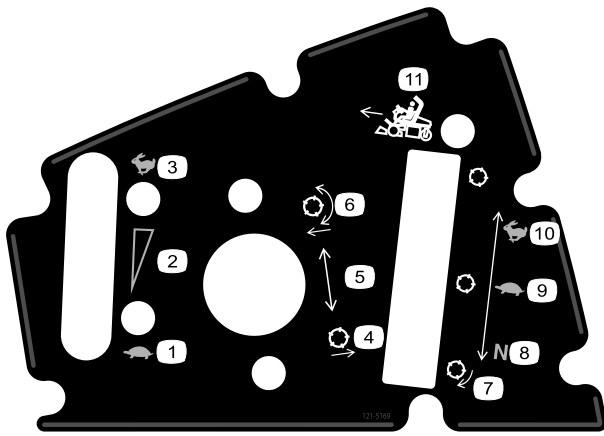

**121-5169**

- |                                |                               |  |
|--------------------------------|-------------------------------|--|
| 1. Slow                        | 4. Raise the reels            | 7. Reel—backlapping—use for transport                    |
| 2. Continuous variable setting | 5. Reel position setting      | 8. Neutral—used for backlapping Functional control lever |
| 3. Fast                        | 6. Lower and engage the reels | 9. Slow—use for mowing                                   |

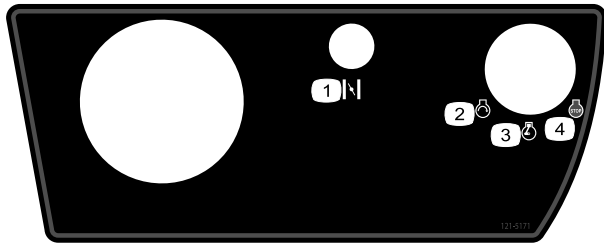

**121-5171**

- |                 |                |
|-----------------|----------------|
| 1. Choke        | 3. Throttle    |
| 2. Engine—start | 4. Engine—stop |

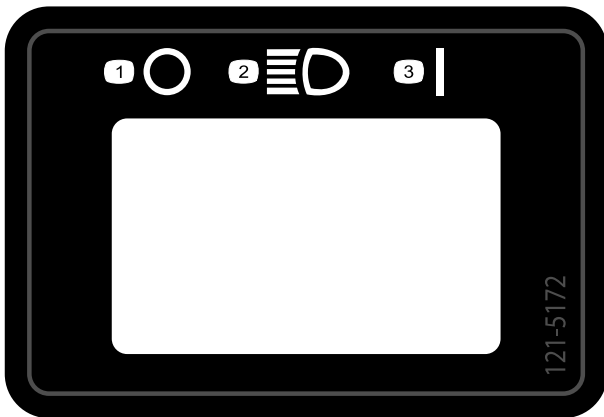

**121-5172**

- |               |       |
|---------------|-------|
| 1. Off        | 3. On |
| 2. Headlights |       |

# GREENMASTER 3300/3320 TriFlex

# QUICK REFERENCE AID



SEE OPERATOR'S  
MANUAL

### CHECK/SERVICE (daily)

1. OIL LEVEL, ENGINE
2. OIL LEVEL, HYDRAULIC TANK
3. BRAKE FUNCTION
4. INTERLOCK SYSTEM:
  - 4a. SEAT INTERLOCK
  - 4b. NEUTRAL SENSOR
  - 4c. MOW SENSOR
  - 4d. PARKING BRAKE INTERLOCK
5. LEAK DETECTOR ALARM
6. AIR FILTER / PRECLEANER
7. ENGINE COOLING FINS
8. TIRE PRESSURE (12 - 16 psi)
9. BATTERY
10. WHEEL NUT TORQUE (70-90 FT LBS)
11. FUEL - GAS
12. REEL SPEED / BACKLAP CONTROL

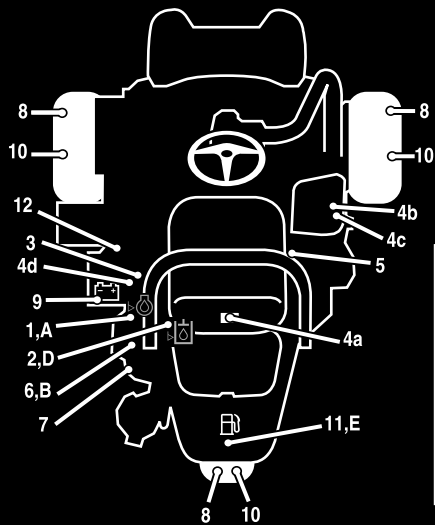

### FLUID SPECIFICATIONS / CHANGE INTERVALS

See operator's manual for initial change	FLUID TYPE	CAPACITY		CHANGE INTERVALS		FILTER PART NO.
		L	QTS.	FLUID	FILTER	
A. ENGINE OIL	SAE 10W-30 SJ	1.6*	1.75*	100 HRS.	100 HRS.	107-7817
B. AIR CLEANER	—	—	—	—	100 HRS.	692519
C. FUEL FILTER	—	—	—	—	1000 HRS.	94-2690
D. HYDRAULIC OIL (3300)	ISO VG 46	22.7*	24*	800 HRS.	800 HRS.	108-5194
D. HYDRAULIC OIL (3320)	ISO VG 46	18.9*	20*	800 HRS.	800 HRS.	108-5194
E. FUEL TANK	UNLEADED GAS	22.7	6 GAL.	—	—	—

\*Including filter

119-9345

119-9345

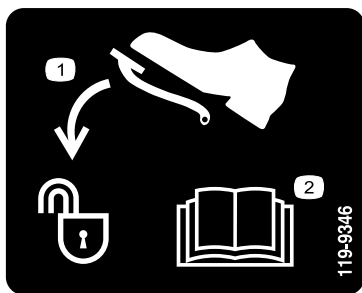

119-9346

1. Press pedal to unlock
2. Read the *Operator's Manual* for more information.



### Battery Symbols

Some or all of these symbols are on your battery

1. Explosion hazard
2. No fire, open flame, or smoking.
3. Caustic liquid/chemical burn hazard
4. Wear eye protection
5. Read the *Operator's Manual*.
6. Keep bystanders a safe distance from the battery.
7. Wear eye protection; explosive gases can cause blindness and other injuries
8. Battery acid can cause blindness or severe burns.
9. Flush eyes immediately with water and get medical help fast.
10. Contains lead; do not discard.

# Setup

## Loose Parts

Use the chart below to verify that all parts have been shipped.

Procedure	Description	Qty.	Use
<b>1</b>	Roll bar	1	Install the roll bar.
	Bolt (1/2 x 3-3/4 inches)	4	
	Flange-nut (1/2 inch)	4	
<b>2</b>	Seat	1	Install the seat to the base.
	Seat wire harness	1	
<b>3</b>	Steering wheel	1	Install the steering wheel.
	Locknut (1-1/2 inches)	1	
	Washer	1	
	Steering wheel cap	1	
<b>4</b>	No parts required	–	Activate and charge the battery.
<b>5</b>	No parts required	–	Install the optional oil cooler.
<b>6</b>	Grass basket hook	6	Install the grass basket hooks.
	Flange bolts	12	
<b>7</b>	Gauge bar	1	Install the cutting units
	Cutting unit (model 04613, 04614, or 04615)	3	
	Cutting unit upper weight	3	
	Hex head screws	6	
	Grass Basket	3	
<b>8</b>	Weight kit, 119-7129 (for two-wheel drive units)	1	Add rear weight.
	Weight kit, 120-5750 (for units with the 3-wheel drive kit installed)	1	
<b>9</b>	Warning decal 121–2640	1	Install EU decals, if required.

## Media and Additional Parts

Description	Qty.	Use
Operator's Manual (traction unit)	1	Read before operating the machine.
Engine Operator's Manual (engine)	1	
Parts Catalog	1	Save for future parts ordering.
Operator Training Materials	1	View before operating the machine.
Pre-delivery Inspection Sheet	1	Save to future reference.
Noise rating certificate	1	
Certificate of compliance	1	
Ignition keys	2	Start the engine.

# 1

## Installing the Roll Bar

### Parts needed for this procedure:

1	Roll bar
4	Bolt (1/2 x 3-3/4 inches)
4	Flange-nut (1/2 inch)

### Procedure

1. Remove the top crate support from the crate.
2. Remove the roll bar from the crate.
3. Install the roll bar into the pockets on each side of the machine, using 4 bolts (1/2 x 3-3/4 inches) and four flange-nuts (1/2 inch) (Figure 3)

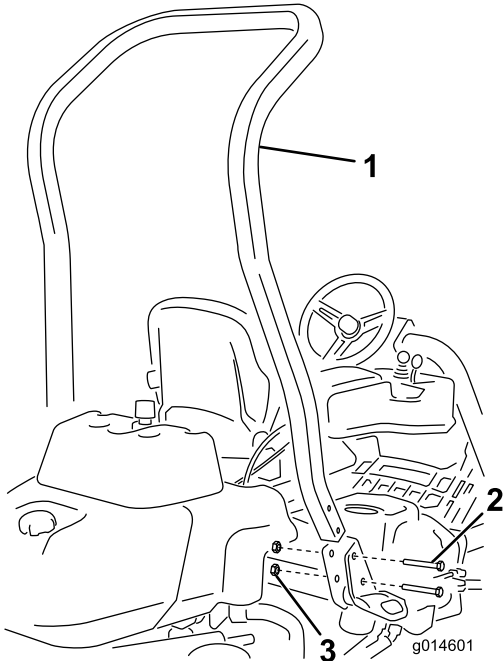

Figure 3

1. Roll bar
2. Bolt (1/2 x 3-3/4 inches)
3. Flange-nut (1/2 inch)

4. Torque the fasteners to 100 to 110 ft-lb (136 to 149 N-m).

# 2

## Installing the Seat

### Parts needed for this procedure:

1	Seat
1	Seat wire harness

### Procedure

**Note:** Mount the seat in the front set of mounting holes to gain an additional 3 inches (7.6 cm) in the forward adjustment, or in the rear mounting holes for an additional 3 inches (7.6 cm) in the rearward adjustment.

1. Remove and discard the lag bolts securing the seat slides and cut the shipping straps.
2. Remove the 4 bolts (5/16 x 3/4 inch) and washers from the shipping bracket and discard the bracket.
3. Secure the seat to the seat base with 4 bolts and washers removed previously (Figure 4).

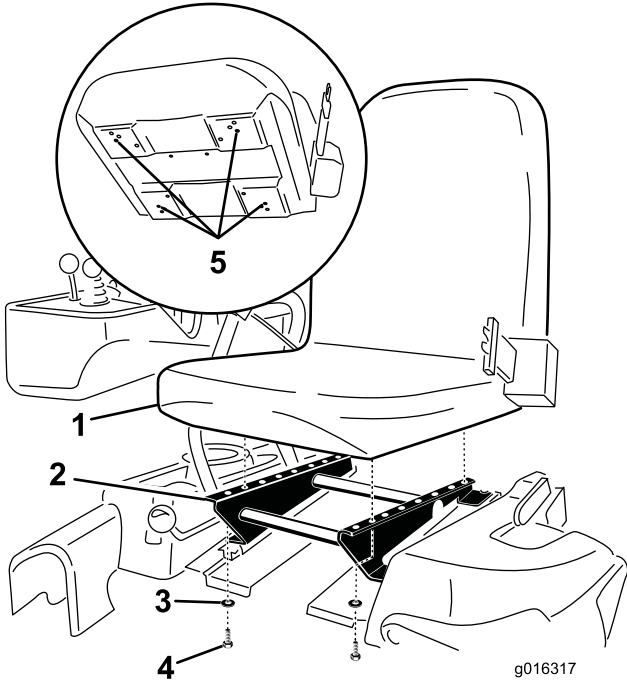

Figure 4

1. Seat
2. Seat base
3. Washer
4. Bolt (5/16 x 3/4 inch)
5. Install the seat using these holes.

4. Locate the open connector on the main wire harness to the right of the seat and connect it to the wire harness that came with the seat.
5. Route the seat wire harness around the seat slides, ensuring that it will not be pinched when the seat moves, and connect it to the port on the bottom of the seat.

# 4

## Activating and Charging the Battery

### No Parts Required

### Procedure

Use only electrolyte (1.265 Specific Gravity) to fill battery initially.

1. Remove the fasteners and battery clamp and lift out the battery.

**Important:** Do not add electrolyte while the battery is in the machine. You could spill it, causing corrosion.

2. Clean the top of the battery and remove the vent caps (Figure 6).

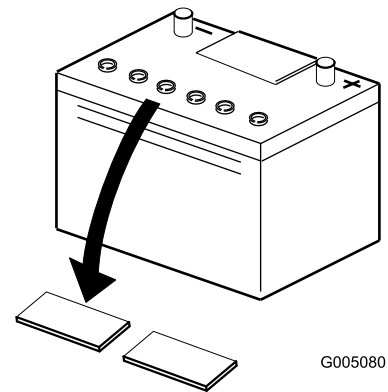

G005080

**Figure 6**

1. Vent caps

3. Carefully fill each cell with electrolyte until the plates are covered with about 1/4 inch (6 mm) of fluid (Figure 7).

# 3

## Installing the Steering Wheel

### Parts needed for this procedure:

1	Steering wheel
1	Locknut (1-1/2 inches)
1	Washer
1	Steering wheel cap

### Procedure

1. Slide the steering wheel onto the steering shaft (Figure 5).

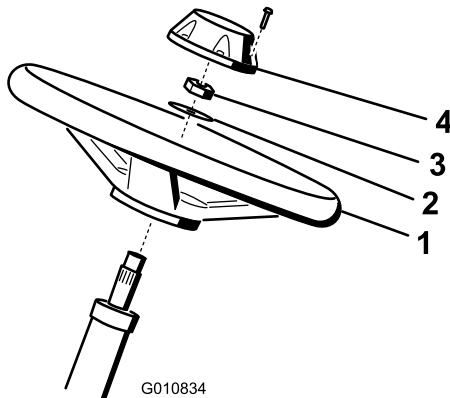

G010834

**Figure 5**

- |                   |            |
|-------------------|------------|
| 1. Steering wheel | 3. Jam nut |
| 2. Washer         | 4. Cap     |

2. Slide the washer onto the steering shaft (Figure 5).
3. Secure the steering wheel to the shaft with a jam nut and tighten it to 20 to 26 ft-lb (27 to 35 N-m) (Figure 5).
4. Install the cap to the steering wheel and secure it with a screw (Figure 5).

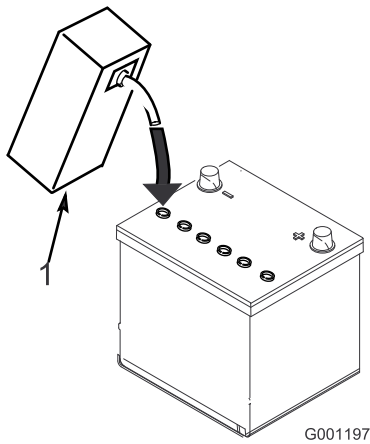

Figure 7

1. Electrolyte

4. Allow approximately 20 to 30 minutes for the electrolyte to soak into the plates. Fill as necessary to bring the electrolyte to within about 1/4 inch (6 mm) of the bottom of the fill well (Figure 7).

**⚠ WARNING**

Charging the battery produces gasses that can explode.

Never smoke near the battery and keep sparks and flames away from battery.

5. Connect a 2 to 4 amp battery charger to the battery posts. Charge the battery for 2 hours at 4 amps or for 4 hours at 2 amps until the specific gravity is 1.250 or higher and the temperature is at least 60°F (16°C) with all cells gassing freely.
6. When the battery is charged, disconnect the charger from the electrical outlet and battery posts.

**Note:** After the battery has been activated, add only distilled water to replace normal loss, although maintenance-free batteries should not require water under normal operating conditions.

**WARNING**

**CALIFORNIA  
Proposition 65 Warning**

Battery posts, terminals, and related accessories contain lead and lead compounds, chemicals known to the State of California to cause cancer and reproductive harm.  
Wash hands after handling.

**⚠ WARNING**

Battery terminals or metal tools could short against metal tractor components causing sparks. Sparks can cause the battery gasses to explode, resulting in personal injury.

- When removing or installing the battery, do not allow the battery terminals to touch any metal parts of the tractor.
- Do not allow metal tools to short between the battery terminals and metal parts of the tractor.

**⚠ WARNING**

Failure to correctly activate the battery may result in battery gassing and/or premature battery failure.

7. Place the battery on the battery tray and secure it with the battery clamp and fasteners removed previously (Figure 8).

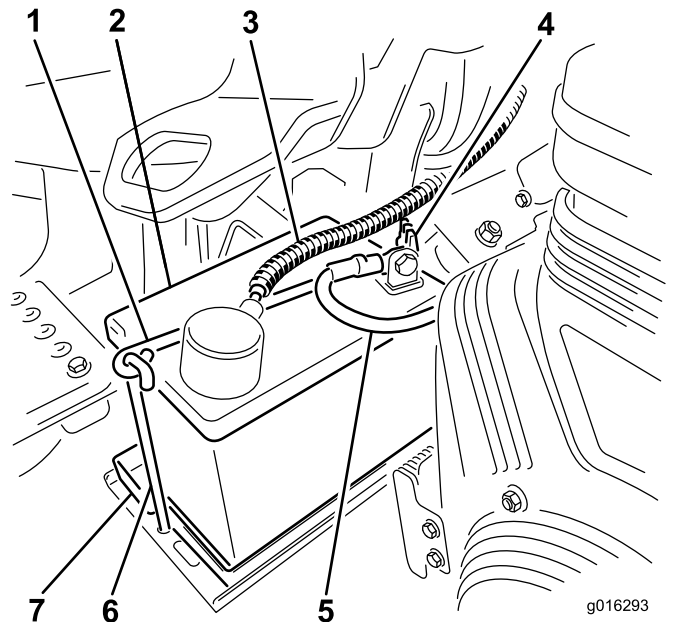

Figure 8

Gasoline model shown, your model may vary.

- |                               |                               |
|-------------------------------|-------------------------------|
| 1. Battery clamp              | 5. Negative (-) battery cable |
| 2. Battery                    | 6. Battery clamp hook         |
| 3. Positive (+) battery cable | 7. Battery tray               |
| 4. Battery clamp wing nut     |                               |

8. Install the positive cable (red) to the positive (+) terminal and then the negative cable (black) to the negative (-) terminal of the battery and secure them with the bolts and nuts (Figure 8). Slide the rubber boot over the positive terminal to prevent a possible short from occurring.

## ⚠ WARNING

Incorrect battery cable routing could damage the tractor and cables causing sparks. Sparks can cause the battery gasses to explode, resulting in personal injury.

- Always disconnect the negative (black) battery cable before disconnecting the positive (red) cable.
- Always connect the positive (red) battery cable before connecting the negative (black) cable.

# 5

## Installing the Optional Oil Cooler

### No Parts Required

### Procedure

If you are operating the machine in hot climates, where the ambient temperature is above 85 degrees F (29 degrees C), or using it for heavy-duty use (mowing other than greens, such as fairways or verticutting), install a Hydraulic Oil Cooler Kit, Part No. 119-1691, to the machine.

# 6

## Installing the Grass Basket Hooks

### Parts needed for this procedure:

6	Grass basket hook
12	Flange bolts

### Procedure

Install the 6 grass basket hooks onto the ends of the suspension arm bars using 12 flange bolts (Figure 9).

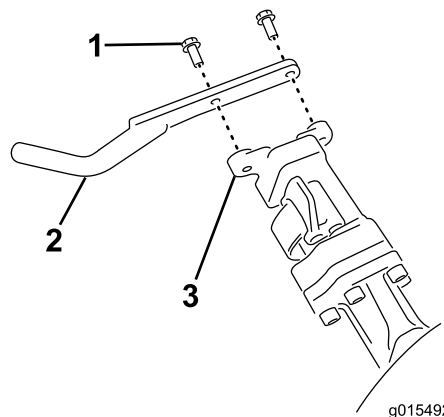

Figure 9

1. Flange bolt
2. Grass basket hook
3. Suspension arm bar

# 7

## Installing the Cutting Units

### Parts needed for this procedure:

1	Gauge bar
3	Cutting unit (model 04613, 04614, or 04615)
3	Cutting unit upper weight
6	Hex head screws
3	Grass Basket

### Procedure

**Note:** When sharpening, setting the height-of-cut, or performing other maintenance procedures on the cutting units, store the cutting unit reel motors in the storage location on the front of the suspension arms to prevent damage to them.

**Important:** Do not raise the suspension to the transport position when the reel motors are in the holders in the machine frame. Damage to the motors or hoses could result.

**Important:** Whenever the cutting unit has to be tipped to expose bedknife/reel, prop up rear of cutting unit to make sure nuts on back end of bedbar adjusting screws are not resting on work surface (Figure 10).

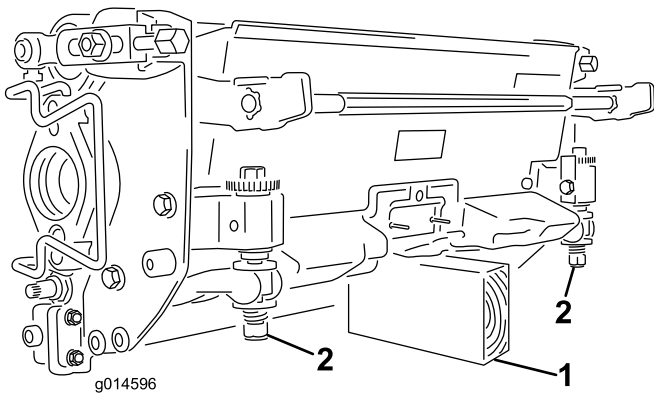

**Figure 10**

1. Prop (not provided)
2. Bedknife adjusting screw nut (2)

**Note:** All cutting units are shipped with the counter weight mounted to the right end and the motor mount and drive coupler mounted to the left end of the cutting unit.

1. Disconnect the cutting unit power disconnect couplers; refer to Cutting Unit Power Disconnect (page 24).

**⚠ CAUTION**

**If you do not disconnect the power to the cutting units, someone could accidentally start the cutting unit, causing serious injury to hands and feet.**

**Always separate the cutting unit power disconnect couplers before working on the cutting units.**

2. Apply grease to the inside diameter of the drive coupler.
3. The cutting unit is shipped without a front roller. Obtain a roller (Model No. 04625, 04626 or 04627) from your local Toro Distributor. Install the roller using the loose parts supplied with the cutting unit and installation instructions included with the roller.
4. Remove the 2 bolts securing the weight to the side of the cutting unit (Figure 11).

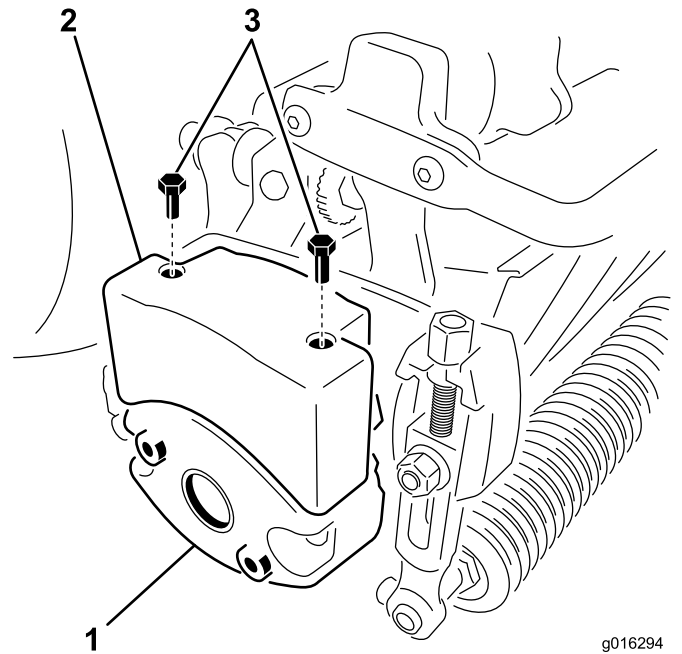

**Figure 11**

1. Cutting until weight (flip over)
2. Upper weight
3. Hex head screws

5. Rotate the weight 180 degrees so that the open screw holes that were on the underside of the weight are now on top. Install the weight to the cutting unit using the bolts removed previously.
6. Install an upper weight to the cutting unit weight using 2 hex head screws (Figure 11).
7. If installing the center cutting unit, lift up on the foot rest and swing it up, allowing access to the center cutting unit position (Figure 12).

**⚠ CAUTION**

**The foot rest can pinch fingers if it falls into the closed position.**

**Keep your fingers clear of the area where the foot rest seats while it is open.**

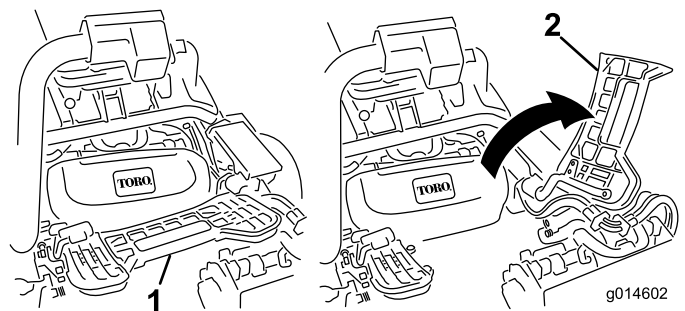

**Figure 12**

1. Footrest—closed
2. Footrest—open

8. Position the cutting unit under the suspension arm.



- With the latches on the suspension-arm bar pointing up (i.e., open) (Figure 13), push the suspension arm down so that the bar fits over the bar across the top of the cutting unit (Figure 14).

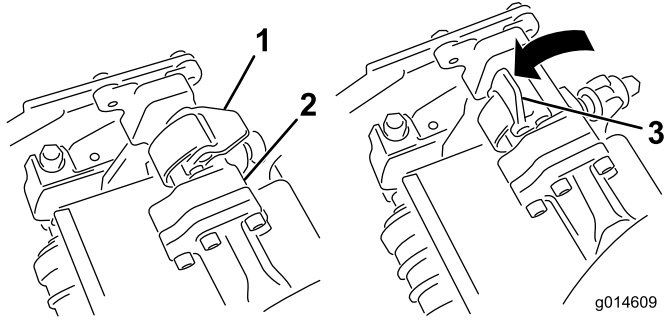

**Figure 13**

- Latch—closed position
- Suspension-arm bar
- Latch—open position

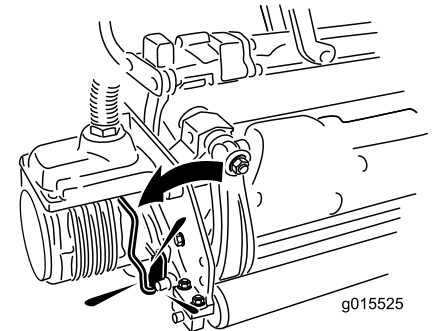
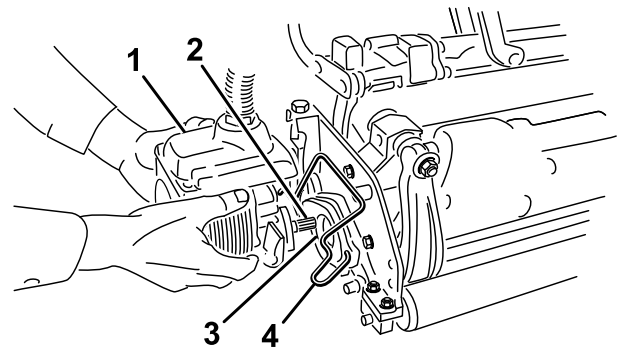

**Figure 15**

- Reel motor
- Spline shaft
- Cavity
- Motor retaining bar

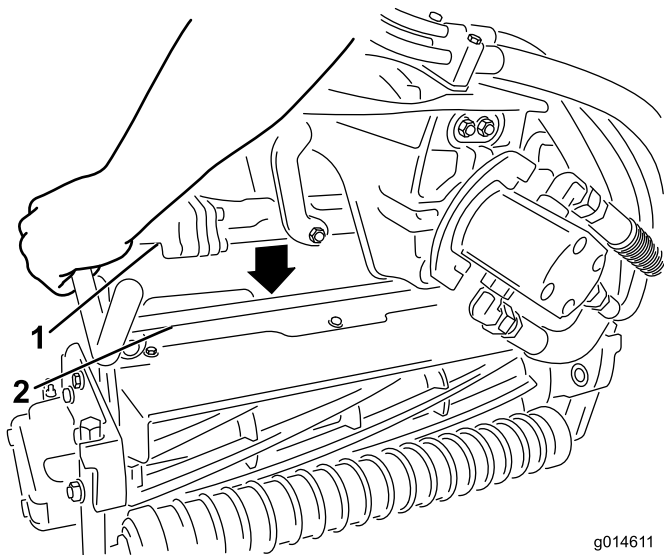

**Figure 14**

- Suspension-arm bar
- Cutting-unit bar

- Close the latches down and around the cutting-unit bar and lock them in place (Figure 13).

**Note:** A “click” can be heard and felt when the latches are properly locked in place.

- Coat the spline shaft of the cutting unit motor with clean grease (Figure 15).
- Insert the motor into the left side of the cutting unit (as viewed from the operator's position) and pull the motor retaining bar on the cutting unit toward the motor until you hear an audible “click” from both sides of the motor (Figure 15).

## 8

### Adding Rear Weight

#### Parts needed for this procedure:

1	Weight kit, 119-7129 (for two-wheel drive units)
1	Weight kit, 120-5750 (for units with the 3-wheel drive kit installed)

#### Procedure

This unit complies with the ANSI B71.4-2004 and EN 836 Standards when equipped with weight kit 119-7129 (2-wheel drive units) or 120-5750 (3-wheel drive units).

# 9

## Installing EU Decals

### Parts needed for this procedure:

1	Warning decal 121–2640
---	------------------------

### Procedure

If this machine will be used in the EU, affix the warning decal 121–2640 over warning decal 121–2641.

## Product Overview

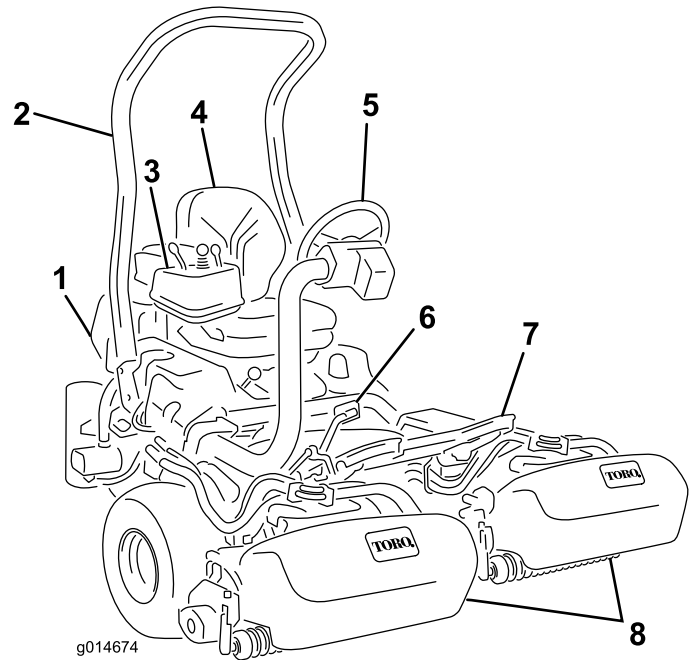

Figure 16

- |                  |                   |
|------------------|-------------------|
| 1. Engine        | 5. Steering wheel |
| 2. Roll bar      | 6. Traction pedal |
| 3. Control panel | 7. Foot rest      |
| 4. Seat          | 8. Cutting units  |

## Controls

### Traction Pedal

The traction pedal (Figure 17) has three functions: to make the machine move forward, to move it backward, and to stop the machine. Press the top of the pedal to move forward and the bottom of the pedal to move backward or to assist in stopping when moving forward. Also, allow the pedal to move to the neutral position to stop the machine. For operator comfort, do not rest the heel of your foot on reverse when operating forward (Figure 18).

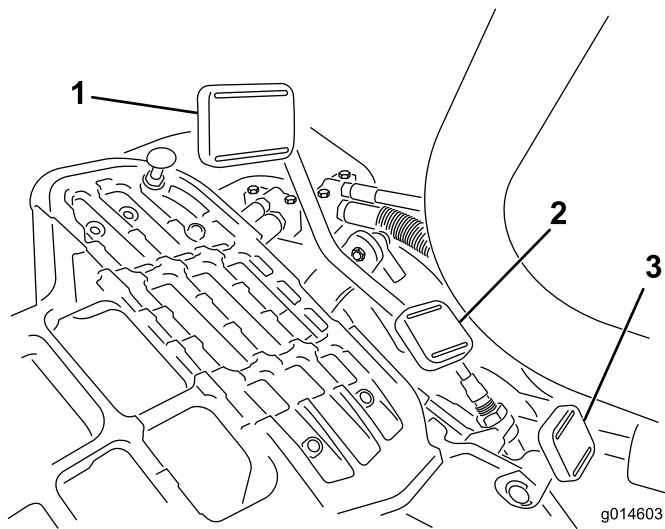

**Figure 17**

- |                           |                               |
|---------------------------|-------------------------------|
| 1. Traction pedal—forward | 3. Steering arm locking pedal |
| 2. Taction pedal—reverse  |                               |

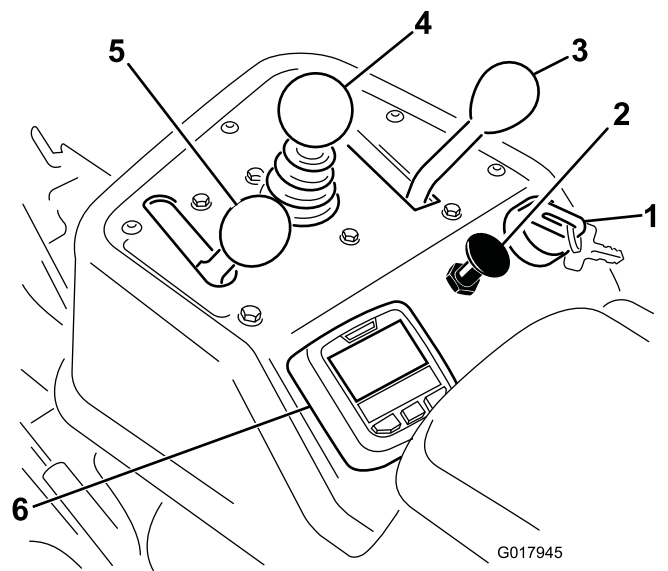

**Figure 19**

- |                             |                            |
|-----------------------------|----------------------------|
| 1. Ignition switch          | 4. Raise/Lower Mow Control |
| 2. Choke                    | 5. Throttle control        |
| 3. Functional control lever | 6. InfoCenter              |



**Figure 18**

## Steering Arm Locking Pedal

Press the pedal (Figure 17) and raise or lower the steering arm for operator comfort, then, release the pedal to lock the arm in place.

**Note:** Move the steering arm fully forward before lifting the seat.

## Throttle Control

The throttle control (Figure 19) gives the operator the ability to control the speed of the engine. Moving the throttle control toward the Fast position increases the engine RPM; moving the throttle control toward Slow will decrease the engine RPM. Ground speeds are as follows:

- 2 to 5 MPH (3.2 to 8 km/h) forward mowing speed
- 10 MPH (16 km/h) maximum transport speed
- 2.5 MPH (4.0 km/h) reverse speed

**Note:** The engine cannot be stopped by the use of the throttle control.

## Choke

To start a cold engine, close the carburetor choke by pulling the choke control (Figure 19) out to the Closed position. After the engine starts, regulate the choke to keep the engine running smoothly. As soon as possible, open the choke by pushing it in to the Open position. A warm engine requires little or no choking.

## Raise/Lower Mow Control

Moving the control (Figure 19) forward during operation lowers the cutting units and starts the reels. Pull back on the control to stop the reels and raise the cutting units. During operation the reels can be stopped by pulling back on the control momentarily and releasing it. This feature is known as Tap-off and is adjustable in the InfoCenter. Restart the reels by moving the control forward.

## Functional Control Lever

The functional control lever (Figure 19) provides two traction selections plus a Neutral position. It is permissible to shift from mow to transport or transport to mow (not to neutral) while the machine is in motion. No damage will result.

- Rear Position—neutral and backlapping
- Middle Position—used for mowing operation
- Front Position—used for transport operation

## Ignition Switch

Insert the key into the switch (Figure 19) and turn it clockwise as far as possible to the Start position to start the engine. Release the key as soon as the engine starts; the key will move to the On position. Turn the key counterclockwise to the Off position to stop the engine.

## Backlap Switch

The backlap switch is located under the plastic cover to the left of the seat. Use the backlap switch (Figure 20) in conjunction with the raise/lower mower control lever and the reel speed control for backlapping the reels.

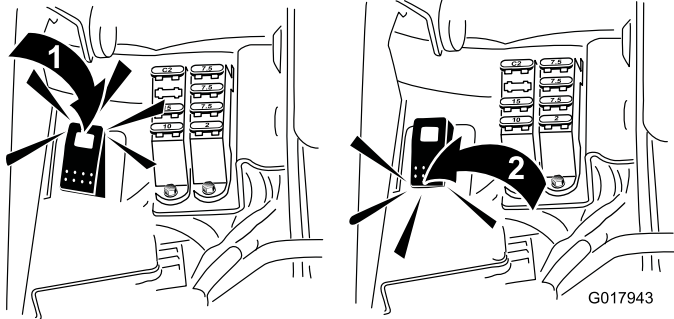
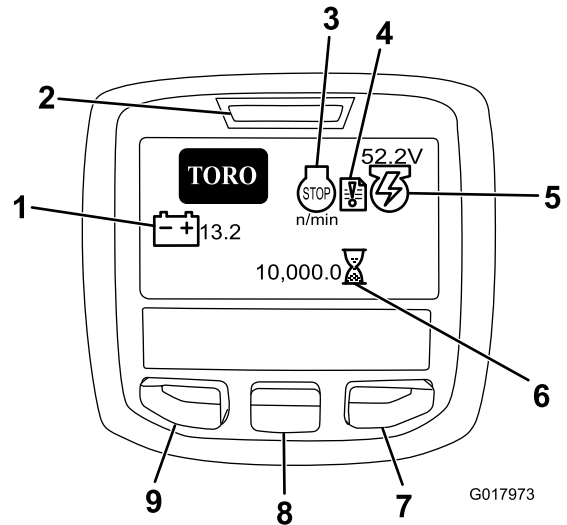

**Figure 20**

1. Backlap switch—backlap position
2. Backlap switch—mow position

## Using the InfoCenter LCD Display

The InfoCenter LCD display shows information about your machine such as the generator status, the speed, and various diagnostics and other information about the machine and the battery pack. Figure 21 and Figure 22 illustrate the splash screen and main information screen of the InfoCenter. You can switch between the splash screen and main information screen at any time by pressing any of the InfoCenter buttons and then selecting the appropriate directional arrow.



**Figure 21**

1. Battery voltage
2. Power light/fault indicator
3. Engine RPM/status
4. Fault log
5. Generator voltage/status
6. Hour meter
7. Right button
8. Down button
9. Menu access/back button

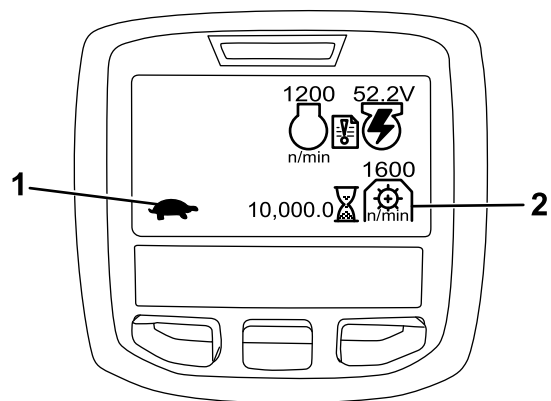

**Figure 22**

1. Functional control status
2. PTO speed

- Engine RPM/status—indicates the engine RPM.
- Fault log—indicates that there is a current fault log to review.
- Generator voltage/status—indicates the generator voltage.

- Hour meter—indicates the total hours the machine has operated. It starts to function whenever the key switch is rotated to On.
- PTO speed—indicates the PTO speed.
- Glow plug—indicates that the glow plug is active.
- Battery voltage—indicates the battery potential in Volts.
- Coolant temperature—indicates the engine coolant temperature in either °C or °F.
- Functional control status—transport mode is indicated by a rabbit and mow mode is indicated by a turtle.
- Engine oil pressure light—this icon appears if the engine oil pressure drops below a safe level.
- Menu access/back button—press this button to access the InfoCenter menus. You can use it to back out of any menu you are currently using.
- Down button—use this button to scroll down menus.
- Right button—use this button to open a menu where a right arrow indicates additional content.

**Note:** The purpose of each button may change depending on what is required at the time. Each button will be labeled with an icon displaying its current function.

## Using the Menus

To access the InfoCenter menu system, press the menu access button while at the main screen. This will bring you to the main menu. Refer to the following tables for a synopsis of the options available from the menus:

Main Menu	
Menu Item	Description
Faults	The Faults menu contains a list of the recent machine faults. Refer to the Service Manual or your Authorized Toro Distributor for more information on the Faults menu and the information contained there.
Service	The Service menu contains information on the machine such as hours of use and other similar numbers.
Diagnostics	The Diagnostics menu lists various states that the machine currently has. You can use this to troubleshoot certain issues as it will quickly tell you which machine controls are on and which are off.
Settings	The Settings menu allows you to customize and modify configuration variables on the InfoCenter display.
About	The About menu lists the model number, serial number, and software version of your machine.

Service	
Menu Item	Description
Hours	Lists the total number of hours that the machine, engine, reels, backlap, and fan have been on, as well as the number of hours the machine has been transported and overheated.
Counts	Lists the number of preheats and starts the machine has experienced.

Diagnostics	
Menu Item	Description
Engine Run	Indicates if the following items are active: Key start, key run, joystick lower, joystick raise, neutral, seat or parking brake, OK run, and RTR or ETR.
S1-S4	Controls the raising and lowering of the solenoids.
Reels Enable	Indicates if the eReel is enabled.

Settings	
Menu Item	Description
Units	Controls the units used on the InfoCenter. The menu choices are English or Metric.
Language	Controls the language used on the InfoCenter.
LCD Backlight	Controls the brightness of the LCD display.
LCD Contrast	Controls the contrast of the LCD display.
Protected Menu	Allows the distributor/engineer to access protected menus by inputting a passcode.
Protection Settings	Controls the protected menus.
Reset Defaults	Resets the InfoCenter to default settings.
Raise Delay	Controls the raise delay time for the center cutting unit.
Lower Delay	Controls the lower delay for the center cutting unit.
Tapoff Delay	Controls the tap-off delay.
Reel Speed	Controls the reel speed.
Backlap RPM	Controls the backlap RPM speed.

About	
Menu Item	Description
Model	Lists the model number of the machine.
SN	Lists the serial number of the machine.
TEC 5001	Lists the software revision of the master controller.
InfoCenter	Lists the software revision of the InfoCenter.
CU1	Lists the software revision of the first cutting unit.
CU2	Lists the software revision of the second cutting unit.
CU3	List the software revision of the third cutting unit.
Generator	Lists the serial number of the generator.
CAN Bus	Lists the machine communication bus status.

## Center Cutting Unit Raise/Lower Delay

The raise and lower delay time for the center cutting may be adjusted independently with the InfoCenter. Each setting may be adjusted from 1 to 9 according to the table below. The factory default setting is 6 (375 ms) and is optimized for a 3.8 MPH mow speed.

Increment Number	Delay Time (Seconds)
1	0.100
2	0.150
3	0.200
4	0.250
5	0.300
6	0.375
7	0.475
8	0.600
9	0.750
10	0.925

## Tap-off Delay

The tap-off delay feature allows the cutting units to turn off without raising, and may be adjusted with the InfoCenter. The delay setting represents the maximum time for the raise/lower joystick to remain in the raise position to activate this feature. The factory default setting is 1 which disables this feature.





Increment Number	Delay Time (Seconds)
1	Off
2	0.050
3	0.100
4	0.150
5	0.200
6	0.250
7	0.300
8	0.350
9	0.400
10	0.450

## Setting the Reel Speed

To achieve a consistent, high quality-of-cut and a uniform after cut appearance, it is important that the reel speed control be correctly set.

Adjust the reel speed control as follows:

1. Select the height-of-cut at which the cutting units are set.
2. Choose the desired ground speed best suited for conditions.
3. Using the appropriate graph (See Figure 23) for 5, 8, 11, or 14 blade cutting units, determine the proper reel speed setting.

							
	3.8 MPH 6.1 Km/h	5.0 MPH 8.0 Km/h	3.8 MPH 6.1 Km/h	5.0 MPH 8.0 Km/h	3.8 MPH 6.1 Km/h	5.0 MPH 8.0 Km/h	3.8 MPH 6.1 Km/h
0.062" / 1.6mm	N/R	N/R	9	N/R	9	N/R	9
0.094" / 2.4mm	N/R	N/R	9	N/R	9	N/R	9
0.125" / 3.2mm	N/R	N/R	9	N/R	9	N/R	9
0.156" / 4.0mm	N/R	N/R	9	N/R	9	N/R	N/R
0.188" / 4.8mm	N/R	N/R	9	N/R	7	N/R	N/R
0.218" / 5.5mm	N/R	N/R	9	N/R	6	N/R	N/R
0.250" / 6.4mm	7	N/R	6	7	5	7	N/R
0.312" / 7.9mm	6	N/R	5	6	4	6	N/R
0.375" / 9.5mm	6	7	4	5	4	5	N/R
0.438" / 11.1mm	6	6	4	5	3	4	N/R
0.500" / 12.7mm	5	6	3	4	N/R	N/R	N/R
0.625" / 15.9mm	4	5	3	3	N/R	N/R	N/R
0.750" / 19.0mm	3	4	3	3	N/R	N/R	N/R
0.875" / 22.2mm	3	4	N/R	3	N/R	N/R	N/R
1.000" / 25.4mm	3	3	N/R	N/R	N/R	N/R	N/R

g014736

Figure 23

4. To set the reel speed, on the InfoCenter open the Main Menu and scroll down to Settings.

- In the Settings menu scroll down to Reel Speed and use the  $\pm$  button to set the reel speed to the desired number.

## Machine Configuration Passcode

There are 5 operating configuration settings that are adjustable within the setting menu of the InfoCenter: Raise and lower delay, tap-off delay, reel speed, and backlap speed. These setting can be protected by a user defined passcode by opening the Main menu and scrolling down to the Settings menu. Find Protect Settings and select ON.

When protect setting “on” is selected the user is prompted to enter a four digit passcode. After the passcode is set, the keyswitch must be turned off and back on to enable and save this feature. After enabling the protect settings option, the configuration settings are hidden until the user defined passcode is entered.

**Note:** If the user defined passcode is forgotten, a temporary passcode can be obtained through your authorized Toro distributor.

## Diagnosing the Fault Log Indicator

The fault log indicator icon appears on the main screen in the event of a fault in the machine (Figure 21). When this icon is present there is a new log entry in the Faults menu that you or your distributor can use to identify the problem.

For a list of faults, refer to your Authorized Distributor or the *Service Manual*.

## Parking Brake Lever

Pull up on the brake lever (Figure 24) to set the parking brake. Disengage it by pushing it forward and down. Set the parking brake any time you leave the machine. An icon will appear on the InfoCenter screen when the parking brake is set.

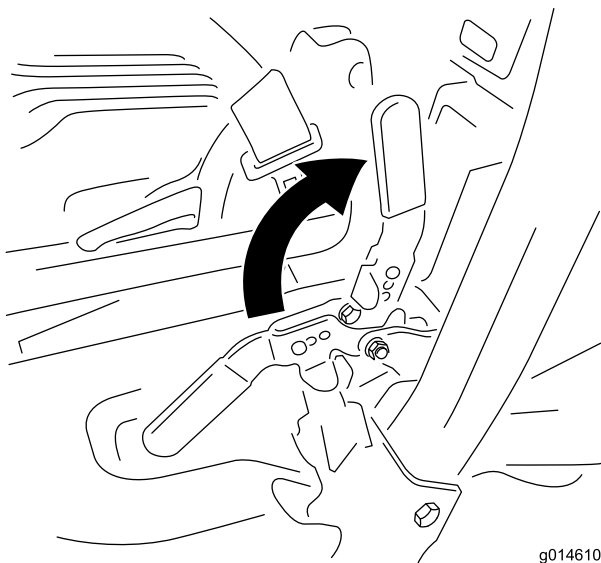

Figure 24

g014610

## Seat Adjusting Lever

The seat adjusting lever is located on the front, right corner of the seat (Figure 25), allowing you to adjust the seat fore and aft. Push the lever to the left (towards the center), to release the lock and slide the seat.

**Note:** If you need additional adjustment on the seat, you can remove the four bolts securing the seat to the base and move the seat to the second set of mounting holes provided.

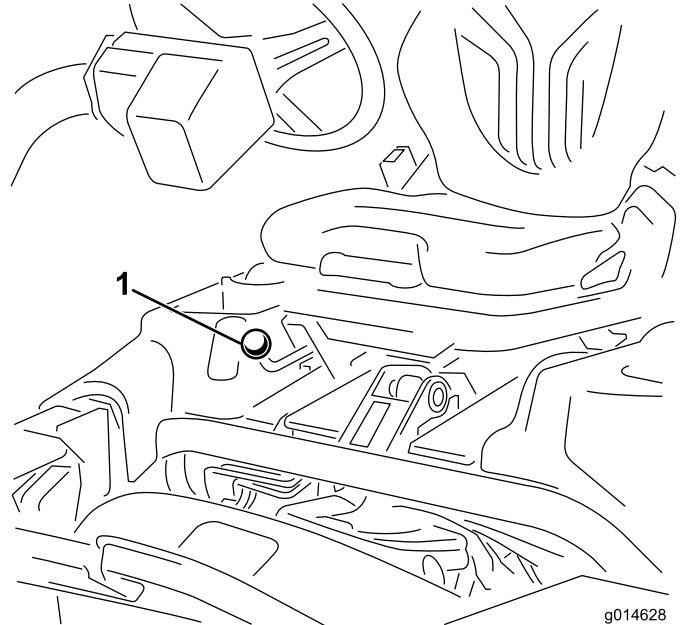

Figure 25

g014628

- Seat adjusting lever

**Note:** Before lifting the seat, slide it to the furthest back position and move the steering arm fully forward.

## Fuel Shut-Off Valve

Close the fuel shut-off valve (Figure 26), behind the seat and under the fuel tank, when storing or transporting the machine on a truck or trailer.

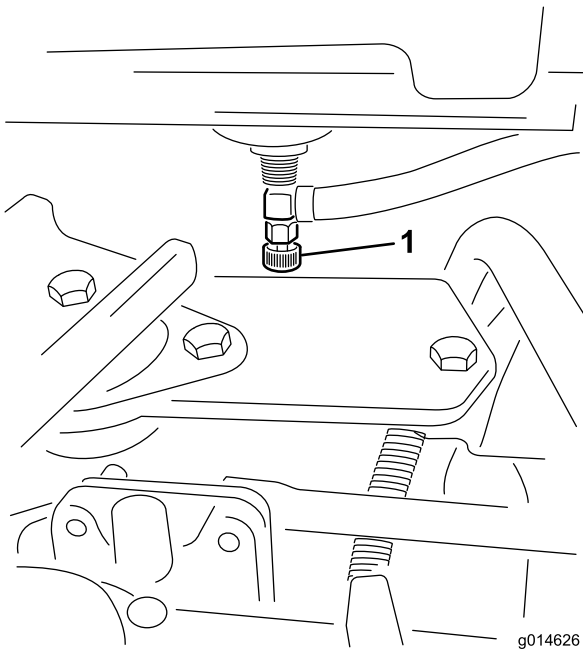
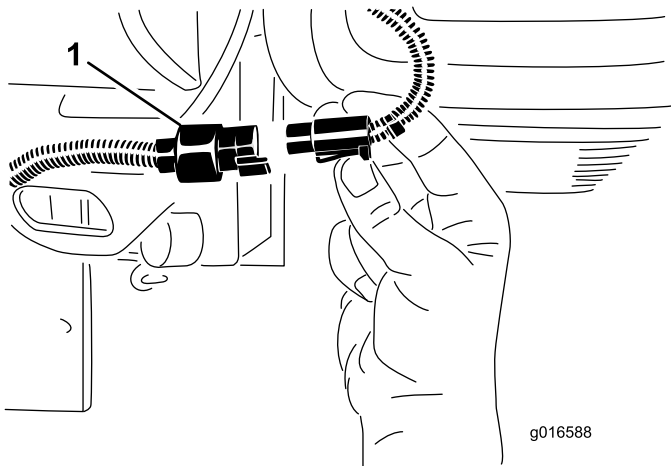

**Figure 26**

1. Fuel shut-off (under the fuel tank)

## Cutting Unit Power Disconnect

Before installing, removing, or working on the cutting units, disconnect the cutting units from the power supply by separating the cutting unit power disconnect connector (Figure 27), located at the base of the rollover bar on the left side of the traction unit. Plug the connectors together before operating the machine.



**Figure 27**

1. Cutting unit power disconnect connector

## ⚠ CAUTION

If you do not disconnect the power to the cutting units, someone could accidentally start the cutting unit, causing serious injury to hands and feet.

Always separate the cutting unit power disconnect connectors before working on the cutting units.

## Specifications

**Note:** Specifications and design are subject to change without notice.

Width of cut	59.5 inches (151 cm)
Wheel tread	50.5 inches (128 cm)
Wheel base	46.9 inches (119 cm)
Overall length (w/baskets)	98.0 inches (249 cm)
Overall width	70.62 inches (179 cm)
Overall height	80.83 inches (205 cm)
Weight	Refer to the traction unit serial tag (Figure 1).

## Attachments/Accessories

A selection of Toro approved attachments and accessories are available for use with the machine to enhance and expand its capabilities. Contact your Authorized Service Dealer or Distributor or go to [www.Toro.com](http://www.Toro.com) for a list of all approved attachments and accessories.



# Operation

**Note:** Determine the left and right sides of the machine from the normal operating position.

## Think Safety First

Please carefully read all of the safety instructions and symbols in the safety section. Knowing this information could help you or bystanders avoid injury.

The use of protective equipment, such as but not limited to, for eyes, ears, feet, and head is recommended.

## Checking the Engine Oil

The engine is shipped with 1-3/4 quarts (1.65 liters) (w/filter) of oil in the crankcase; however, the oil level must be checked before and after the engine is first started.

The engine uses any high-quality detergent oil having the American Petroleum Institute (API) service classification of SG, SH, or SJ or higher. The recommended viscosity (weight) is SAE 30.

1. Position the machine on a level surface.
2. Unscrew the dipstick and wipe it with a clean rag. Screw the dipstick into the tube and make sure it is seated fully (Figure 28).

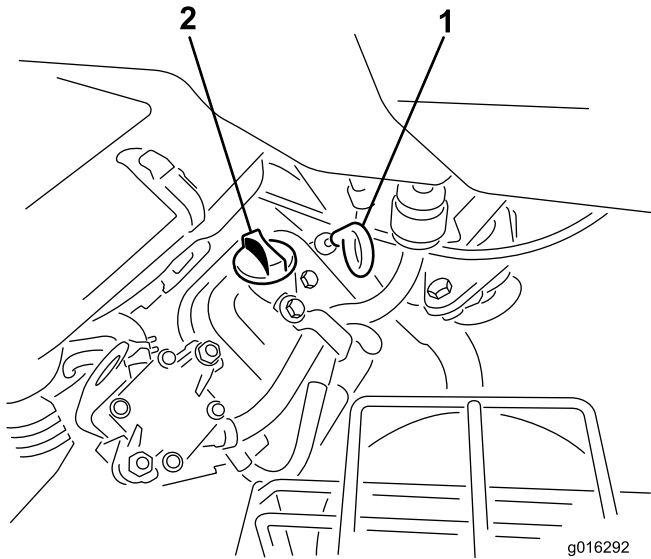

**Figure 28**

1. Dipstick
2. Filler cap

**Important:** Check the oil level every 8 operating hours or daily.

5. Install the filler cap and dipstick firmly in place.

## Filling the Fuel Tank

Use **unleaded** regular gasoline suitable for automotive use (87 pump octane minimum). Leaded regular gasoline may be used if unleaded regular is not available.

**Important:** Never use methanol, gasoline containing methanol, or gasohol containing more than 10% ethanol because the fuel system could be damaged. Do not mix oil with gasoline.

### **⚠ DANGER**

**In certain conditions, gasoline is extremely flammable and highly explosive. A fire or explosion from gasoline can burn you and others and can damage property.**

- Fill the fuel tank outdoors, in an open area, when the engine is cold. Wipe up any gasoline that spills.
- Never fill the fuel tank inside an enclosed trailer.
- Do not fill the fuel tank completely full. Add gasoline to the fuel tank until the level is 1 inch (25 mm) below the bottom of the filler neck. This empty space in the tank allows gasoline to expand.
- Never smoke when handling gasoline, and stay away from an open flame or where gasoline fumes may be ignited by a spark.
- Store gasoline in an approved container and keep it out of the reach of children. Never buy more than a 30-day supply of gasoline.
- Do not operate without entire exhaust system in place and in proper working condition.

3. Unscrew the dipstick out of the tube and check the oil level.
4. If the oil level is low, remove the filler cap from the valve cover and pour oil into the opening in the valve cover until the oil level is up to the Full mark on the dipstick. Add the oil slowly and check the level often during this process. **Do not overfill.**

## **▲ DANGER**

In certain conditions during fueling, static electricity can be released causing a spark which can ignite the gasoline vapors. A fire or explosion from gasoline can burn you and others and can damage property.

- Always place gasoline containers on the ground away from your vehicle before filling.
- Do not fill gasoline containers inside a vehicle or on a truck or trailer bed because interior carpets or plastic truck bed liners may insulate the container and slow the loss of any static charge.
- When practical, remove gas-powered equipment from the truck or trailer and refuel the equipment with its wheels on the ground.
- If this is not possible, then refuel such equipment on a truck or trailer from a portable container, rather than from a gasoline dispenser nozzle.
- If a gasoline dispenser nozzle must be used, keep the nozzle in contact with the rim of the fuel tank or container opening at all times until fueling is complete.

1. Clean around the fuel tank cap and remove it (Figure 29).

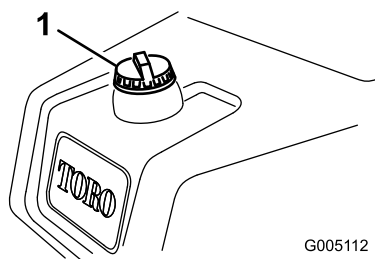

Figure 29

1. Fuel tank cap

2. Add unleaded regular gasoline to the fuel tank until the level is 1 inch (25 mm) below the bottom of the filler neck.

This space in the tank allows gasoline to expand. **Do not fill the fuel tank completely full.**

**Note:** The fuel tank capacity is 6 US gallons (22.7).

3. Install the fuel tank cap securely. Wipe up any gasoline that may have spilled.

## Checking the Hydraulic Fluid Level

The hydraulic fluid reservoir is filled at the factory with approximately 5 US gallons (18.9 l) of high quality hydraulic

fluid. Before operating the machine each day, check level of the hydraulic fluid in the white plastic window on the front of the hydraulic fluid reservoir (behind the seat on the left side). The fluid should be between the lines in the window; if not, add an appropriate fluid as described in the following sections:

## Recommended Hydraulic Fluid

The recommended replacement fluid is as follows:

**Toro Premium All Season Hydraulic Fluid** (Available in 5 gallon pails or 55 gallon drums. See parts catalog or Toro distributor for part numbers.)

Alternate fluids: If the Toro fluid is not available, other fluids may be used provided they meet all the following material properties and industry specifications. We do not recommend the use of synthetic fluid. Consult with your lubricant distributor to identify a satisfactory product

**Note:** Toro will not assume responsibility for damage caused by improper substitutions, so use only products from reputable manufacturers who will stand behind their recommendation.

### High Viscosity Index/Low Pour Point Anti-wear Hydraulic Fluid, ISO VG 46

Material Properties:

Viscosity, ASTM D445      cSt @ 40°C 44 to 48  
cSt @ 100°C 7.9 to 8.5

Viscosity Index ASTM      140 to 160  
D2270

Pour Point, ASTM D97      -34°F to -49°F

Industry Specifications:

Vickers I-286-S (Quality Level), Vickers M-2950-S (Quality Level), Denison HF-0, Vickers 35 VQ (Eaton ATS373-C)

**Important:** The ISO VG 46 Multigrade fluid has been found to offer optimal performance in a wide range of temperature conditions. For operation in consistently high ambient temperatures, 65° F (18° C) to 120° F (49° C), ISO VG 68 hydraulic fluid may offer improved performance.

**Premium Biodegradable Hydraulic Fluid-Mobil EAL EnviroSyn 46H**

**Important:** Mobil EAL EnviroSyn 46H is the only synthetic biodegradable fluid approved by Toro. This fluid is compatible with the elastomers used in Toro hydraulic systems and is suitable for a wide-range of temperature conditions. This fluid is compatible with conventional mineral oils, but for maximum biodegradability and performance the hydraulic system should be thoroughly flushed of conventional fluid. The oil is available in 5 gallon (19 l) containers or 55 gallon drums from your Mobil Distributor.

**Note:** Many hydraulic fluids are almost colorless, making it difficult to spot leaks. A red dye additive for the hydraulic system oil is available in 2/3 oz. (20 ml) bottles. One bottle is sufficient for 4-6 gal (15-22 l) of hydraulic oil. Order part no. 44-2500 from your authorized Toro distributor. **This**

red dye is not recommended for use with biodegradable fluids. Use food coloring.

**Important:** Regardless of the hydraulic fluid type used, any traction unit used for off green applications, verticutting or used during ambient temperatures above 85° F (29° C) should have Oil Cooler Kit installed; refer to 5 Installing the Optional Oil Cooler (page 15).

## Filling the Hydraulic Tank

1. Position the machine on a level surface. Make sure the machine has cooled down so the oil is cold.
2. Remove the cap from the reservoir (Figure 30).

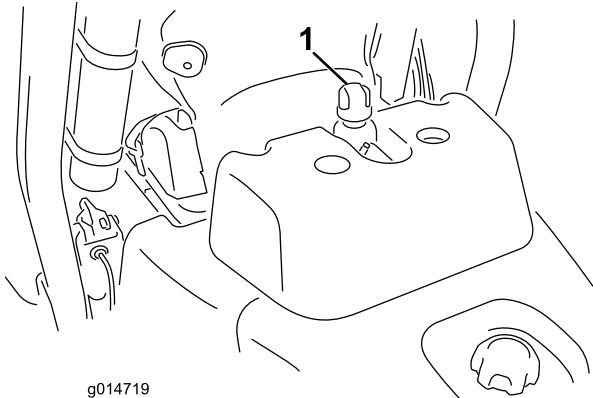

Figure 30

1. Hydraulic tank cap

3. Slowly fill the reservoir with the appropriate hydraulic fluid until the level is at or within 0.25 inch (6 mm) of the arrow in the symbol next to the white window in the front of the reservoir (Figure 31). Do not overfill.

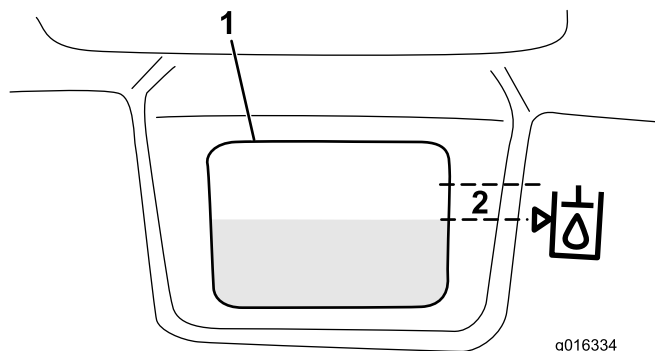

Figure 31

1. White window on the front of the hydraulic reservoir
2. Fill to within this area.

**Important:** To prevent system contamination, clean the top of the hydraulic fluid containers before puncturing. Ensure the pour spout and funnel are clean.

4. Install the reservoir cap. Wipe up any fluid that may have spilled.

**Important:** Check level of hydraulic fluid before engine is first started and daily thereafter.

## Checking the Reel-to-Bedknife Contact

Each day before operating the machine, check the reel-to-bedknife contact, regardless if the quality of cut had previously been acceptable. There must be light contact across the full length of the reel and bedknife; refer to Adjusting the Reel to Bedknife in the Cutting Unit Operator's Manual.

Before checking the reels, disconnect the cutting unit power disconnect couplers; refer to Cutting Unit Power Disconnect (page 24). Connect them when finished.

### ⚠ CAUTION

If you do not disconnect the power to the cutting units, someone could accidentally start the cutting unit, causing serious injury to hands and feet.

Always separate the cutting unit power disconnect couplers before working on the cutting units.

## Checking the Tire Pressure

The tires are over-inflated at the factory for shipping purposes. Reduce the pressure to the proper levels before starting the unit.

Vary the tire pressure for all 3 wheels, depending upon your turf conditions, from a minimum of 12 psi to a maximum of 16 psi (83 to 110 kPa).

## Checking the Torque of the Wheel Nuts

### ⚠ WARNING

Failure to maintain proper torque of the wheel nuts could result in personal injury.

Torque the wheel nuts to 70 to 90 ft-lb (95 to 122 N-m) after 1-4 hours of operation and again after 10 hours of operation. Torque every 200 hours thereafter.

## Break-in Period

Refer to the Engine Manual supplied with the machine for oil change and maintenance procedures recommended during the break-in period.

Only 8 hours of mowing operation is required for the break-in period.

Since the first hours of operation are critical to future dependability of the machine, monitor its functions and performance closely so that minor difficulties, which could lead to major problems, are noted and can be corrected. Inspect the machine frequently during break-in for signs of oil leakage, loose fasteners, or any other malfunction.

To ensure optimum performance of the brake system, burnish (break-in) the brakes before using the machine. To burnish the brakes, firmly apply the brakes and drive the machine at mowing speed until the brakes are hot, as indicated by their smell. An adjustment to the brakes may be required after break-in; refer to Adjusting the Brakes.

## Starting the Engine

**Note:** Inspect the area beneath the mowers to be certain they are clear of debris.

1. Sit on the seat, lock the parking brake, disengage the raise/lower mow control and move the functional control lever to Neutral.
2. Remove your foot from the traction pedal and make sure the pedal is in the Neutral position.
3. Move the choke lever to the closed position (only when starting a cold engine) and the throttle lever to the half throttle position.
4. Insert and rotate the ignition key clockwise until the engine starts. After the engine starts, regulate the choke to keep the engine running smoothly. As soon as possible, open the choke by pushing it in to the Off position. A warm engine requires little or no choking.
5. Check the machine out with the following procedures after the engine has started:
  - A. Move the functional control lever to the Mow position and release the parking brake. Move the throttle control to the Fast position and momentarily engage the reels by moving the raise/lower mow control lever forward. The cutting units should drop and all the reels should turn.
  - B. Move the raise/lower mow control lever rearward. The cutting reels should stop and the cutting units should raise to the full transport position.
  - C. Set the brake to keep the machine from moving, and operate the traction pedal through the forward and reverse positions.
  - D. Continue the above procedure for 1-2 minutes. Neutralize the functional control lever, lock the parking brake, and turn the engine off.
  - E. Check for oil leaks. If oil leaks appear, check the tightness of the hydraulic fittings. If oil leaks continue to appear, contact your local

Toro Distributor for assistance and, if necessary, replacement parts.

**Important:** A trace of oil on the motor or wheel seals is normal. Seals require a small amount of lubrication to perform properly.

**Note:** When the machine is new and the bearings and reels are tight, it is necessary to use the Fast throttle control position for this check. A fast throttle setting may not be required after the break-in period.

## Checking the Safety Interlock System

### ⚠ CAUTION

If the safety interlock switches are disconnected or damaged the machine could operate unexpectedly causing personal injury.

- Do not tamper with the interlock switches.
- Check the operation of the interlock switches daily and replace any damaged switches before operating the machine.

The purpose of the safety interlock system is to prevent operation of the machine where there is possible injury to the operator or the machine.

The safety interlock system prevents the engine from starting unless:

- The traction pedal is in neutral.
- The functional control lever is in neutral.

The safety interlock system prevents the machine from moving unless:

- The parking brake is off.
- The operator is seated.
- The functional control lever is in Mow or Transport.

The safety interlock system prevents the reels from operating unless the functional control lever is in the Mow position.

Perform the following system checks daily to be sure the interlock system is operating correctly:

1. Sit on the seat, move the traction pedal to Neutral, move the functional control lever to Neutral, and engage the parking brake. Try to depress the traction pedal. The pedal should not depress, which means that the interlock system is operating correctly. Correct the problem if it is not operating properly.
2. Sit on the seat, move the traction pedal to Neutral, move the functional control lever to Neutral, and engage the parking brake. Move the functional control

lever to mow or transport and try to start the engine. The engine should not crank, which means that the interlock system is operating correctly. Correct the problem if it is not operating properly.

3. Sit on the seat, move the traction pedal to Neutral, move the functional control lever to Neutral, and engage the parking brake. Start the engine and move the functional control lever to mow or transport. The engine should kill, which means that the interlock system is operating correctly. Correct the problem if it is not operating properly.
4. Sit on the seat, move the traction pedal to Neutral, move the functional control lever to Neutral, and engage the parking brake. Start the engine. Release the parking brake, move the functional control lever to mow, and rise from the seat. The engine should kill, which means that the interlock system is operating correctly. Correct the problem if it is not operating properly.
5. Sit on the seat, move the traction pedal to Neutral, move the functional control lever to Neutral, and engage the parking brake. Start the engine. Move the raise/lower mow control forward to lower the cutting units. The cutting units should not start rotating. If they do, the interlock system is not operating correctly. Correct the problem.

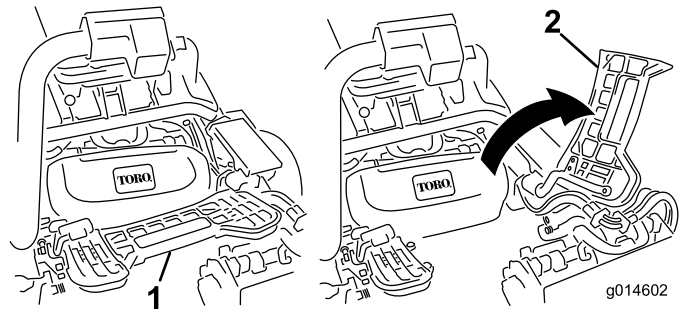

**Figure 32**

1. Footrest—closed
2. Footrest—open

3. Position the cutting unit under the center suspension arm.
4. With the latches on the suspension-arm bar pointing up (i.e., open) (Figure 33), push the suspension arm down so that the bar fits over the bar across the top of the cutting unit (Figure 34).

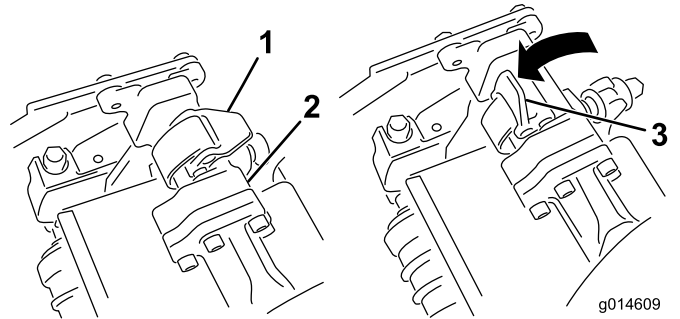

**Figure 33**

1. Latch—closed position
2. Suspension-arm bar
3. Latch—open position

## Installing and Removing the Cutting Units

### Installing the Cutting Units

1. Disconnect the cutting unit power disconnect couplers; refer to Cutting Unit Power Disconnect (page 24).

#### **CAUTION**

If you do not disconnect the power to the cutting units, someone could accidentally start the cutting unit, causing serious injury to hands and feet.

Always separate the cutting unit power disconnect couplers before working on the cutting units.

2. Lift up on the foot rest and swing it open, allowing access to the center cutting unit position (Figure 32).

#### **CAUTION**

The foot rest can pinch fingers if it falls into the closed position.

Keep your fingers clear of the area where the foot rest seats while it is open.

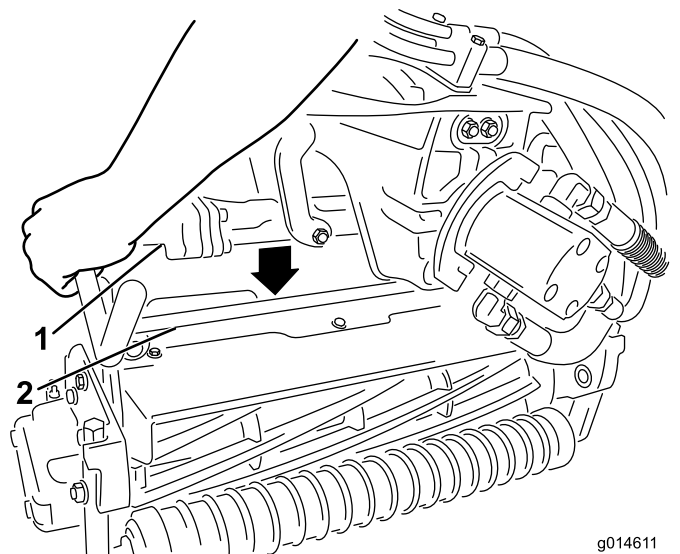

**Figure 34**

1. Suspension-arm bar
2. Cutting-unit bar

5. Close the latches down and around the cutting-unit bar and lock them in place (Figure 33).

**Note:** A “click” can be heard and felt when the latches are properly locked in place.

- Coat the spline shaft of the cutting unit motor with clean grease (Figure 35).
- Insert the motor into the left side of the cutting unit (as viewed from the operator's position) and pull the motor retaining bar on the cutting unit toward the motor until you hear an audible “click” from both sides of the motor (Figure 35).

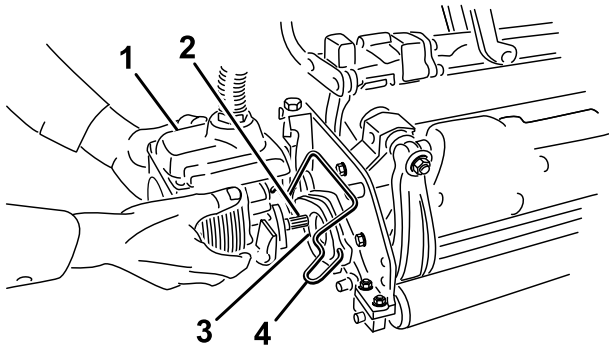

**Figure 35**

- |                 |                        |
|-----------------|------------------------|
| 1. Reel motor   | 3. Cavity              |
| 2. Spline shaft | 4. Motor retaining bar |

- Mount a grass basket onto the basket hooks on the suspension arm.
- Repeat this procedure for the other cutting units.
- Connect the cutting unit power disconnect couplers; refer to Cutting Unit Power Disconnect (page 24).

## Removing the Cutting Units

- Disconnect the cutting unit power disconnect couplers; refer to Cutting Unit Power Disconnect (page 24).

### **CAUTION**

If you do not disconnect the power to the cutting units, someone could accidentally start the cutting unit, causing serious injury to hands and feet.

Always separate the cutting unit power disconnect couplers before working on the cutting units.

- Park the machine on a clean level surface, lower the cutting units to the ground until the suspension hydraulics are fully extended, stop the engine, and set the parking brake.
- Push the motor retaining bar out of the slots on the motor towards the cutting unit and remove the motor from the cutting unit.

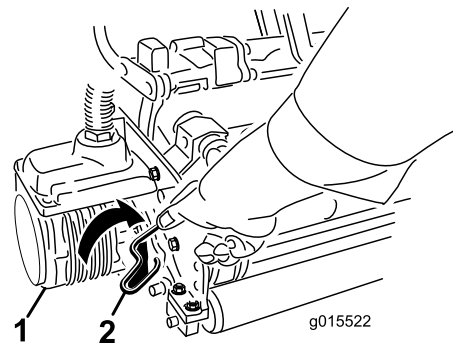

**Figure 36**

- |               |                        |
|---------------|------------------------|
| 1. Reel motor | 2. Motor retaining bar |
|---------------|------------------------|

- Move the motor to the storage location on the front of the suspension arm (Figure 37).

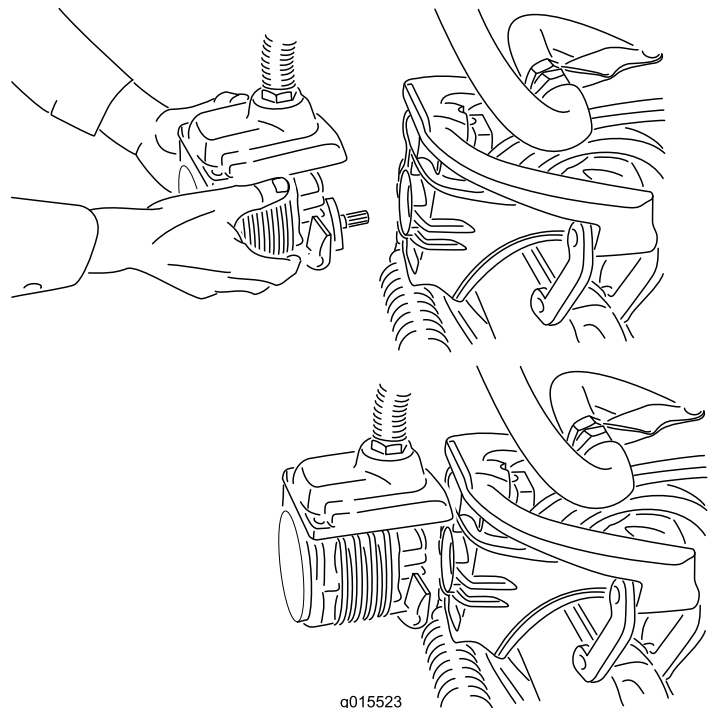

**Figure 37**

**Note:** When sharpening, setting the height-of-cut, or performing other maintenance procedures on the cutting units, store the cutting unit reel motors in the storage location on the front of the suspension arms to prevent damage to them.

**Important:** Do not raise the suspension to the transport position when the reel motors are in the holders in the machine frame. Damage to the

**motors or hoses could result. If you must move the traction unit without the cutting units installed, secure them to the suspension arms using cable ties.**

5. Open the latches on the suspension-arm bar of the cutting unit you are removing (Figure 33).
6. Disconnect the latches from the cutting-unit bar.
7. Roll the cutting unit out from under the suspension arm.
8. Repeat steps 3 through 7 for the other cutting units as required.
9. Connect the cutting unit power disconnect couplers; refer to Cutting Unit Power Disconnect (page 24).

## Training Period

Before mowing greens with the machine, it is recommended that you find a clear area and practice starting and stopping, raising and lowering the cutting units, turning, etc. This training period will be beneficial to the operator in gaining confidence in the performance of the machine.

## Before Mowing

Inspect the green for debris, remove the flag from the cup, and determine the best direction to mow. Base the direction to mow on the previous mowing direction. Always mow in an alternate pattern from the previous mowing so that the grass blades will be less apt to lay down and therefore be difficult to trap between the reel blades and bedknife.

## Mowing

1. Approach the green with the functional control lever in the Mow position and the throttle at full speed. Start on one edge of the green so the ribbon procedure of cutting may be used. This holds compaction to a minimum and leaves a neat, attractive pattern on the greens.
2. Actuate the raise/lower mow lever as the front edge of the grass baskets cross the outer edge of the green. This procedure drops the cutting units to the turf and starts the reels.

**Important:** Familiarize yourself with the fact that the No. 1 cutting unit reel is delayed and therefore, you should practice to try to gain the required timing necessary to minimize the cleanup mowing operation.

3. Overlap a minimal amount with the previous cut on return passes. To assist in maintaining a straight line across the green and keep the machine an equal distance from the edge of the previous cut, establish an imaginary sight line approximately 6 to 10 ft (1.8 to 3 m) ahead of the machine to the edge of the uncut portion of the green ( and Figure 38). Some find it useful to

include the outer edge of the steering wheel as part of the sight line; i.e. keep the steering wheel edge aligned with a point that is always kept the same distance away from the front of the machine ( and Figure 38).

4. As the front of the baskets cross the edge of the green, move the raise/lower mow lever rearward. This will stop the reels and lift the cutting units. Timing of this procedure is important, so the mowers do not cut into the fringe area. However, as much of the green as possible should be cut to minimize the amount of grass left to mow around the outer periphery.
5. Cut down on operating time and ease lineup for the next pass by momentarily turning the machine in the opposite direction, then turning in the direction of the uncut portion; i.e., if intending to turn right, first swing slightly left, then right. This will assist in getting the machine more quickly aligned for the next pass. Follow the same procedure for turning in the opposite direction. It is a good practice to try to make as short of a turn as possible. However, turn in a wider arc during warmer weather to minimize the possibility of bruising the turf.

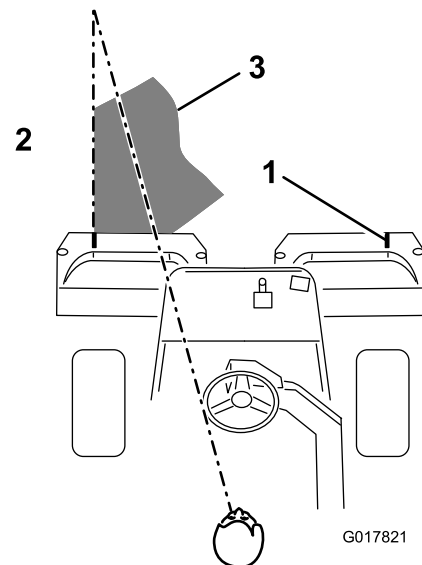

**Figure 38**

1. Alignment marker
2. Cut grass on left
3. Keep focal spot 6-10 ft (1.8-3 m) ahead of the machine.

**Note:** Due to the nature of the power steering system, the steering wheel will not return to its original position after a turn has been completed.

**Important:** The machine should never be stopped on a green with the cutting unit reels operating as damage to the turf may result. Stopping on a wet green with the machine may leave marks or indentations from the wheels.

6. If the leak detector alarm sounds while cutting on a green, immediately raise the cutting units, drive directly

off of the green and stop the machine in an area away from the green. Determine the cause of the alarm and correct the problem.

7. Finish cutting the green by mowing the outer periphery. Be sure to change the direction of cutting from the previous mowing. Always keep weather and turf conditions in mind and be sure to change the direction of mowing from the previous cutting. Replace the flag.
8. At the end of the periphery cut, momentarily pull back on the Raise/Lower Mow Control lever to shut the reels off without raising them. Continue moving forward until the reels stop rotating, then drive off the green and raise the reels. This will help prevent dribbling grass onto the green while raising the reels.
9. Empty the grass baskets of all clippings before transporting to the next green. Heavy wet clippings place an undue strain on the baskets and will add unnecessary weight to the machine, thereby increasing the load on the engine, hydraulic system, brakes, etc.

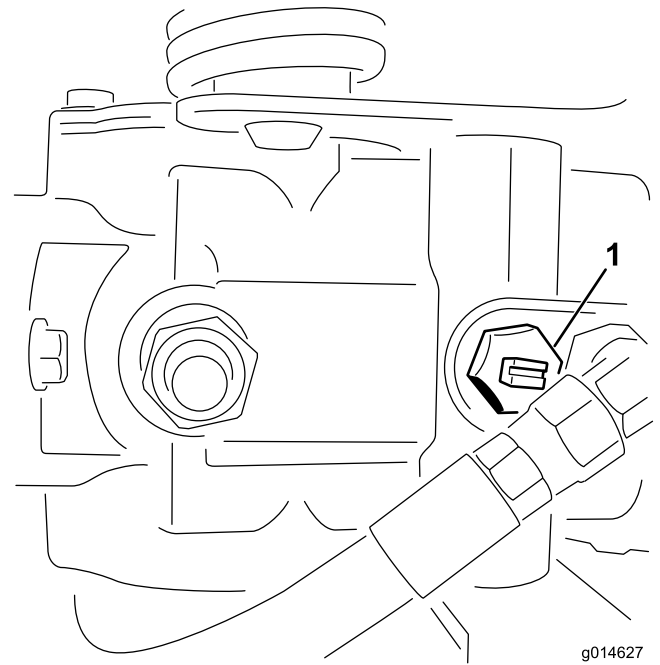

**Figure 39**

1. Bypass valve-slot shown in closed (horizontal) position

2. Before starting the engine, close the bypass valve by rotating it so that the slot is horizontal (Figure 39). Do not start the engine when the valve is open.

## Transport Operation

Make sure the cutting units are in the full up position. Move the functional control lever to the transport position. Use the traction pedal to slow the machine while going down steep hills to avoid loss of control. Always approach rough areas at a reduced speed and cross severe undulations carefully. Familiarize yourself with the width of the machine. Do not attempt to pass between objects that are close together so that costly damage and down time can be prevented.

## Inspection and Cleanup After Mowing

At the completion of the mowing operation, thoroughly wash the machine with a garden hose without a nozzle so excessive water pressure will not cause contamination and damage to the seals and bearings. After cleaning, inspect the machine for possible hydraulic fluid leaks, damage or wear to hydraulic and mechanical components, and the cutting units for sharpness. Also, lubricate the mow and lift pedal and brake shaft assembly with SAE 30 oil or spray lubricant to deter corrosion and help keep the machine performing satisfactorily during the next mowing operation.

## Towing the Traction Unit

In case of an emergency the machine can be towed for a short distance (less than 1/4 mile (0.4 km)). However, Toro does not recommend this as standard procedure.

**Important: Do not tow the machine faster than 2-3 MPH (3-5 km/h) because the drive system may be damaged. If the machine must be moved a considerable distance, transport it on a truck or trailer.**

1. Locate the bypass valve on the pump and rotate it so that the slot is vertical (Figure 39).



# Maintenance

**Note:** Determine the left and right sides of the machine from the normal operating position.

**Important:** Refer to your engine *Operator's Manual* for additional maintenance procedures.

## **▲ CAUTION**

If you leave the key in the ignition switch, someone could accidentally start the engine and seriously injure you or other bystanders.

Remove the key from the ignition and disconnect the wire from the spark plug before you do any maintenance. Set the wire aside so that it does not accidentally contact the spark plug.

## Recommended Maintenance Schedule(s)

Maintenance Service Interval	Maintenance Procedure
After the first hour	<ul style="list-style-type: none"><li>• Check the torque of the wheel nuts.</li></ul>
After the first 8 hours	<ul style="list-style-type: none"><li>• Check the torque of the wheel nuts.</li></ul>
After the first 25 hours	<ul style="list-style-type: none"><li>• Change the engine oil and filter.</li></ul>
After the first 50 hours	<ul style="list-style-type: none"><li>• Change the hydraulic oil filter.</li><li>• Check the engine RPM (at idle and full throttle).</li></ul>
Before each use or daily	<ul style="list-style-type: none"><li>• Check the engine oil.</li><li>• Check the hydraulic fluid level.</li><li>• Check the reel-to-bedknife contact.</li><li>• Check the safety interlock system.</li><li>• Inspect and cleanup after mowing.</li><li>• Check the hydraulic lines and hoses.</li></ul>
Every 50 hours	<ul style="list-style-type: none"><li>• Service the air cleaner foam pre-cleaner (more frequently when operating conditions are dusty or dirty).</li><li>• Check the battery electrolyte level.</li><li>• Check the battery cable connections.</li></ul>
Every 100 hours	<ul style="list-style-type: none"><li>• Service the air cleaner cartridge (more frequently when operating conditions are dusty or dirty).</li><li>• Change the engine oil and filter.</li></ul>
Every 200 hours	<ul style="list-style-type: none"><li>• Check the torque of the wheel nuts.</li></ul>
Every 400 hours	<ul style="list-style-type: none"><li>• Grease the machine.</li></ul>
Every 800 hours	<ul style="list-style-type: none"><li>• Replace the spark plugs.</li><li>• Replace the fuel filter. (Replace sooner if the fuel flow is restricted.)</li><li>• Change the hydraulic oil, filter, and tank breather.</li><li>• Check the engine RPM (at idle and full throttle).</li><li>• Check the valve clearance.</li></ul>
Every 2 years	<ul style="list-style-type: none"><li>• Check the fuel lines and connections.</li><li>• Replace moving hoses.</li></ul>

# Daily Maintenance Checklist

Duplicate this page for routine use.

Maintenance Check Item	For the week of:						
	Mon.	Tues.	Wed.	Thurs.	Fri.	Sat.	Sun.
Check the safety interlock operation.							
Check the instrument operation							
Check the leak detector alarm (if equipped).							
Check the brake operation.							
Check the fuel level.							
Check the hydraulic oil level.							
Check the engine oil level.							
Clean the engine air cooling fins.							
Inspect the air filter pre-cleaner.							
Check any unusual engine noises.							
Check the reel-to-bedknife adjustment.							
Check the hydraulic hoses for damage.							
Check for fluid leaks.							
Check the tire pressure.							
Check the height-of-cut adjustment.							
Touch-up damaged paint.							

Notation for Areas of Concern		
Inspection performed by:		
Item	Date	Information

# Lubrication

## Greasing the Machine

**Service Interval:** Every 400 hours

Lubricate the grease fitting with No. 2 General Purpose Lithium-Base Grease.

1. Wipe the grease fitting clean so foreign matter cannot be forced into the bearing or bushing (Figure 40).

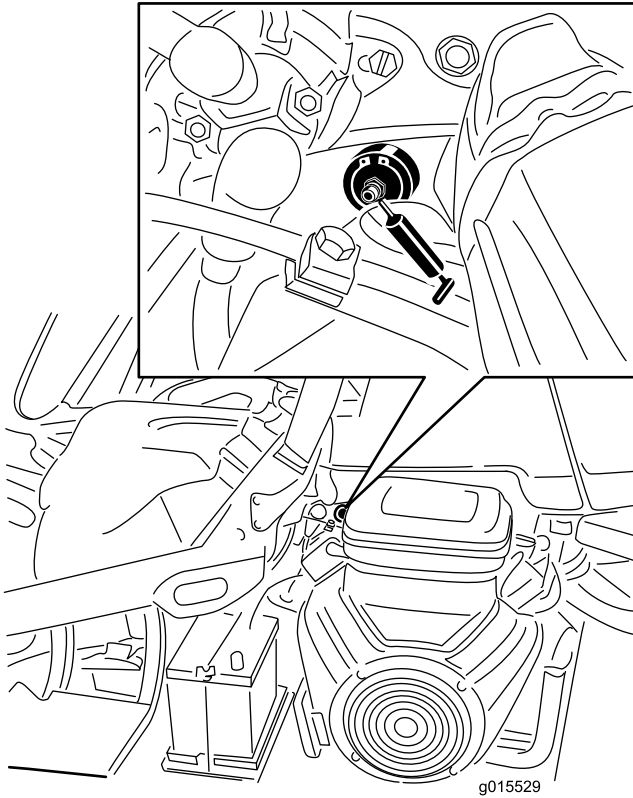

**Figure 40**

Left side of gasoline model shown; your model may vary

2. Pump grease into the bearing or bushing until the grease is visible. Wipe up excess grease.

# Engine Maintenance

## Servicing the Air Cleaner

**Service Interval:** Every 50 hours—Service the air cleaner foam pre-cleaner (more frequently when operating conditions are dusty or dirty).

Every 100 hours—Service the air cleaner cartridge (more frequently when operating conditions are dusty or dirty).

1. Release the locking clips and remove the air cleaner cover (Figure 41). Clean the cover thoroughly.

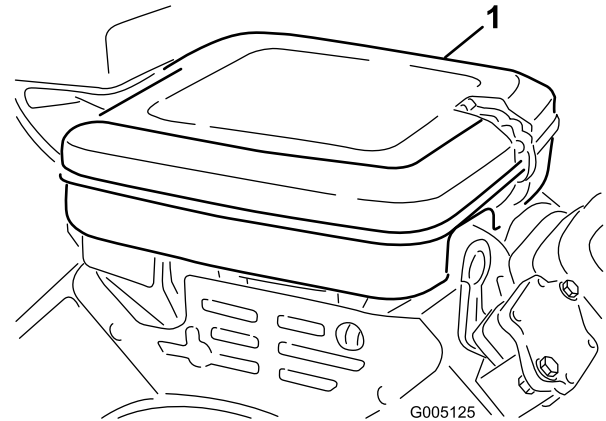

**Figure 41**

1. Air cleaner cover

2. Remove the wing nut securing the elements to the air cleaner body.
3. If the foam element is dirty, remove it from the paper element (Figure 42). Clean it thoroughly, as follows:
  - A. Wash the foam element in a solution of liquid soap and warm water. Squeeze it to remove dirt, but do not twist it because the foam may tear.
  - B. Dry it by wrapping it in a clean rag. Squeeze the rag and foam element dry.

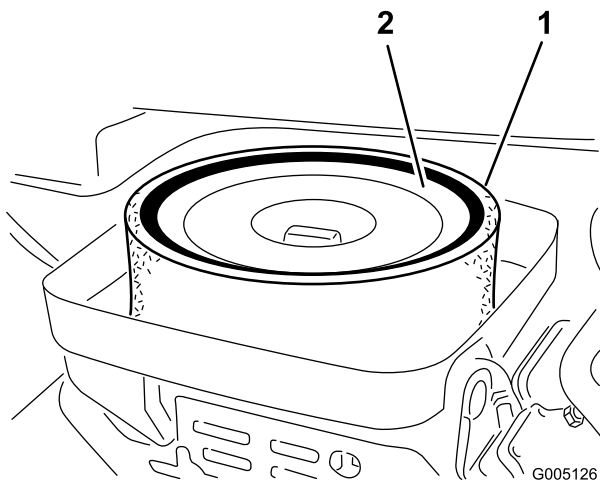

**Figure 42**

1. Foam element                      2. Paper element

4. When servicing the foam element, check the condition of the paper element. Clean it by gently tapping it on a flat surface or replace it if needed.
5. Install the foam element, paper element, and air cleaner cover.

**Important:** Do not operate the engine without the air cleaner element because extreme engine wear and damage will likely result.

## Changing the Engine Oil and Filter

**Service Interval:** After the first 25 hours  
Every 100 hours

1. Remove the drain plug (Figure 43) and let oil flow into a drain pan. When the oil stops, install the drain plug.

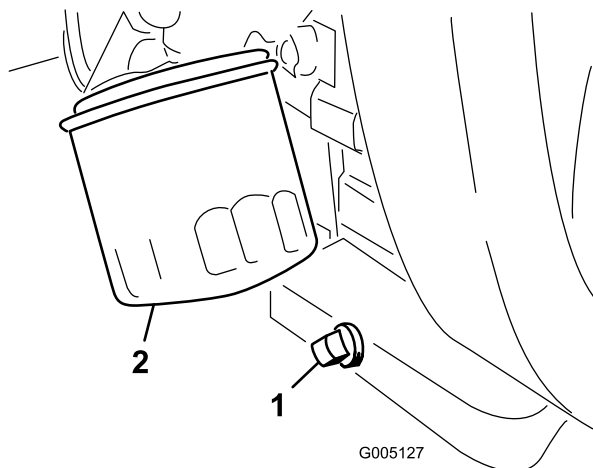

**Figure 43**

1. Drain plug                              2. Oil filter

2. Remove the oil filter (Figure 43). Apply a light coat of clean oil to the new filter gasket.

3. Screw the filter on by hand until the gasket contacts the filter adapter, then tighten 1/2 to 3/4 turn further. **Do not overtighten.**
4. Add oil to the crankcase; refer to Checking the Engine Oil (page 25).
5. Dispose of the used oil properly.

## Replacing the Spark Plugs

**Service Interval:** Every 800 hours

The recommended air gap is 0.030 inch (0.76 mm)

The correct spark plug to use is a Champion RC 14YC.

**Note:** The spark plug usually lasts a long time; however, the plug should be removed and checked whenever the engine malfunctions.

1. Clean the area around the spark plugs so foreign matter cannot fall into the cylinder when the spark plug is removed.
2. Pull the spark plug wires off of the spark plugs and remove the plugs from the cylinder head.
3. Check the condition of the side electrode, center electrode, and center electrode insulator to ensure that there is no damage.

**Important:** Replace a cracked, fouled, dirty, or otherwise malfunctioning spark plug. Do not sand blast, scrape, or clean electrodes by using a wire brush because grit may eventually release from the plug, fall into the cylinder, and damage the engine.

4. Set the air gap between the center and side of the electrodes at 0.030 inch (0.76 mm) (Figure 44).

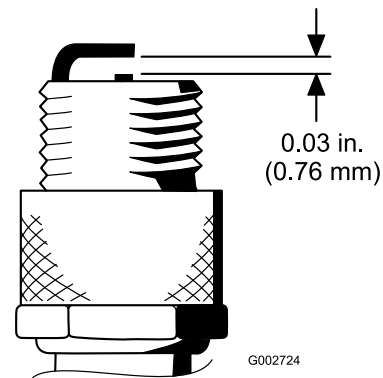

**Figure 44**

5. Install the correctly gapped spark plug with gasket seal, and tighten the plug to 200 in-lb (23 N-m). If a torque wrench is not used, tighten the plug firmly.

# Fuel System Maintenance

## Replacing the Fuel Filter

**Service Interval:** Every 800 hours (Replace sooner if the fuel flow is restricted.)

An in-line filter is incorporated into the fuel line between the fuel tank and carburetor (Figure 45). Be sure the arrow on the filter is pointing away from the fuel tank.

### ⚠ DANGER

In certain conditions, gasoline is extremely flammable and highly explosive. A fire or explosion from gasoline can burn you and others and can damage property.

- Drain gasoline from the fuel tank when the engine is cold. Do this outdoors in an open area. Wipe up any gasoline that spills.
  - Never smoke when draining gasoline, and stay away from an open flame or where a spark may ignite the gasoline fumes.
1. Close the fuel shut off valve, loosen the hose clamp on the carburetor side of filter, and remove the fuel line from the filter (Figure 45).

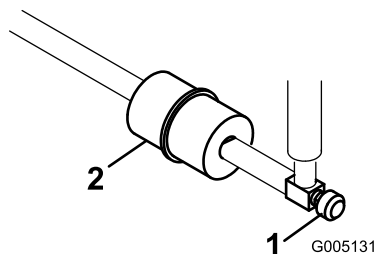

Figure 45

1. Fuel shut off valve
2. Fuel filter

2. Place a drain pan under the filter, loosen the remaining hose clamp and remove the filter (Figure 45).
3. Install the new filter with the arrow on the filter body pointing away from the fuel tank.

## Fuel Lines and Connections

**Service Interval:** Every 2 years

Inspect the fuel lines for deterioration, damage, or loose connections.

# Electrical System Maintenance

## Servicing the Battery

Properly maintain the battery electrolyte and keep the top of the battery clean. Store the machine in a cool place to prevent the battery from running down.

Check the electrolyte level every 50 operating hours or, if machine is in storage, every 30 days.

### ⚠ DANGER

Battery electrolyte contains sulfuric acid which is a deadly poison and causes severe burns.

- Do not drink electrolyte and avoid contact with skin, eyes or clothing. Wear safety glasses to shield your eyes and rubber gloves to protect your hands.
- Fill the battery where clean water is always available for flushing the skin.

Maintain the cell level with distilled or demineralized water. Do not fill the cells above the bottom of the split ring inside each cell.

Keep the top of the battery clean by washing it periodically with a brush dipped in ammonia or bicarbonate of soda solution. Flush the top surface with water after cleaning it. Do not remove the fill caps while cleaning the battery.

The battery cables must be tight on the terminals to provide good electrical contact.

### ⚠ WARNING

Incorrect battery cable routing could damage the tractor and cables causing sparks. Sparks can cause the battery gasses to explode, resulting in personal injury.

- Always disconnect the negative (black) battery cable before disconnecting the positive (red) cable.
- Always connect the positive (red) battery cable before connecting the negative (black) cable.

If corrosion occurs at the terminals, disconnect the cables, negative (-) cable first, and scrape the clamps and terminals separately. Reconnect the cables, positive (+) cable first, and coat the terminals with petroleum jelly.

## WARNING

### CALIFORNIA Proposition 65 Warning

Battery posts, terminals, and related accessories contain lead and lead compounds, chemicals known to the State of California to cause cancer and reproductive harm. Wash hands after handling.

## Servicing the Fuses

The fuses in the machine's electrical system are located under the seat (Figure 46).

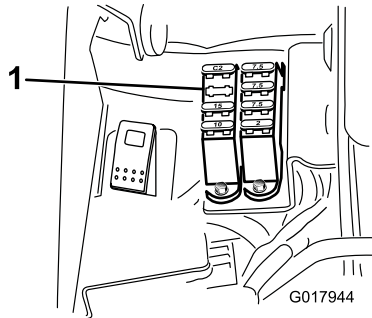

Figure 46

### 1. Fuses

Fuse Layout	
Hydraulic Fan Kit 15 A	Lift Reel E-Reel Enable  7.5 A
	Reel Engage Lift/Lower  7.5 A
Lights  Leak Detector 15 A	Start/Run Diag. Lights Leak Detector 7.5 A
Run  10 A	ECM Logic Power 2 A

## Drive System Maintenance

### Adjusting the Transmission for Neutral

If the machine creeps when the traction control pedal is in the neutral position, the neutral return mechanism must be adjusted.

1. Block up under the frame so that one of the front wheels is off of the floor.

**Note:** Note: If machine is equipped with a 3 wheel drive kit, also raise and block rear wheel.

2. Start the engine, move the throttle to Slow, and check the front wheel that is off of the floor; it must not be rotating.
3. If the wheel is rotating, stop the engine and proceed as follows:
  - A. Loosen the nut securing the eccentric to the top of the hydrostat (Figure 47).

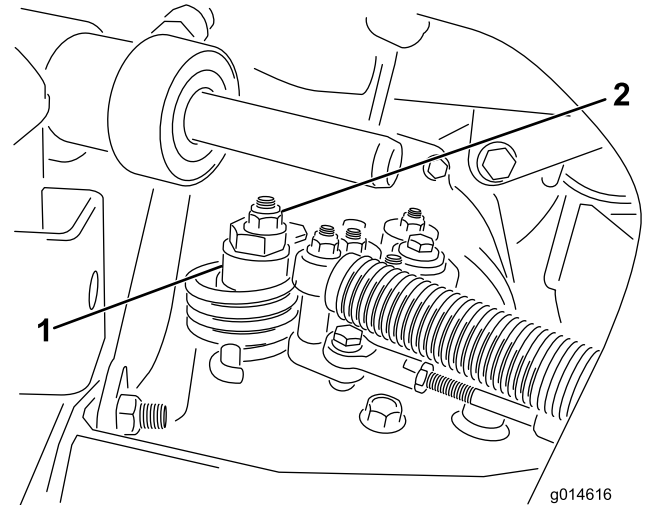

Figure 47

1. Eccentric
2. Locknut

- B. Move the functional control lever to Neutral and the throttle to Slow. Start the engine.
- C. Rotate the eccentric until creep does not occur in either direction. When the wheel stops rotating, tighten the nut locking the eccentric and the adjustment (Figure 47). Verify the adjustment with the throttle in the Slow and Fast position.

**Note:** If the wheel still turns when the eccentric is at the maximum adjustment, contact your Authorized Service Distributor or refer to the *Service Manual* for further adjustment.

# Adjusting the Transport Speed

## Obtaining Maximum Transport Speed

The traction pedal is adjusted for maximum transport speed at the factory, but an adjustment may be required if the pedal reaches full stroke before it contacts the pedal stop, or if a decrease in transport speed is desired.

To obtain maximum transport speed, put the functional control lever in the transport position and press down on the traction pedal. If the pedal contacts the stop (Figure 48) before tension is felt on the cable, an adjustment is required:

1. Put the functional control lever in the transport position and loosen the locknut securing the pedal stop to the floor plate (Figure 48).
2. Tighten the pedal stop until it does not contact the traction pedal.
3. Continue applying a light load on the transport pedal and adjust the pedal stop so it contacts the pedal rod and tighten the nuts.

**Important:** The tension on the cable must not be excessive or cable life will be reduced.

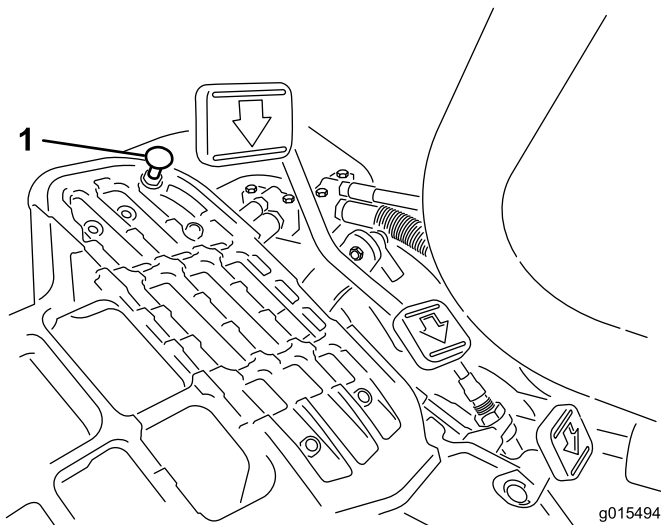

Figure 48

1. Pedal stop

1. Loosen the jam nut on the trunnion bolt (Figure 49).
2. Loosen the nut securing the lock and mow brackets on the pedal pivot.

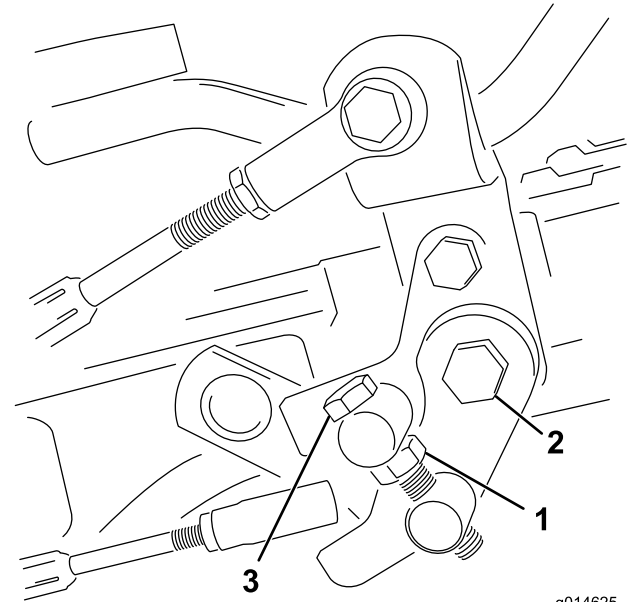

Figure 49

1. Jam nut
2. Nut
3. Trunnion bolt

3. Rotate the trunnion bolt clockwise to reduce the mowing speed and counterclockwise to increase the mowing speed.
4. Tighten the jam nut on the trunnion bolt and the nut on the pedal pivot to lock the adjustment (Figure 49). Check the adjustment and adjust as required.

## Reducing Transport Speed

1. Press down on the traction pedal and loosen the locknut securing the pedal stop to the floor plate.
2. Loosen the pedal stop until the desired transport speed is obtained.
3. Tighten the locknut securing the pedal stop.

## Adjusting the Mowing Speed

The machine is adjusted at the factory, but speed may be varied if desired.

# Brake Maintenance

## Adjusting the Brakes

If the brake fails to hold the machine while parked, you can adjust the brakes using the bulkhead fitting near the brake drum; contact your Authorized Service Distributor or refer to the *Service Manual* for more information.

# Hydraulic System Maintenance

## Changing the Hydraulic Oil and Filter

**Service Interval:** After the first 50 hours

Every 800 hours

If the oil becomes contaminated, contact your local Toro distributor because the system must be flushed. Contaminated oil looks milky or black when compared to clean oil.

1. Clean the area around the filter mounting area (Figure 50). Place a drain pan under the filter and remove the filter.

**Note:** If the oil is not going to be drained, disconnect and plug the hydraulic line going to the filter.

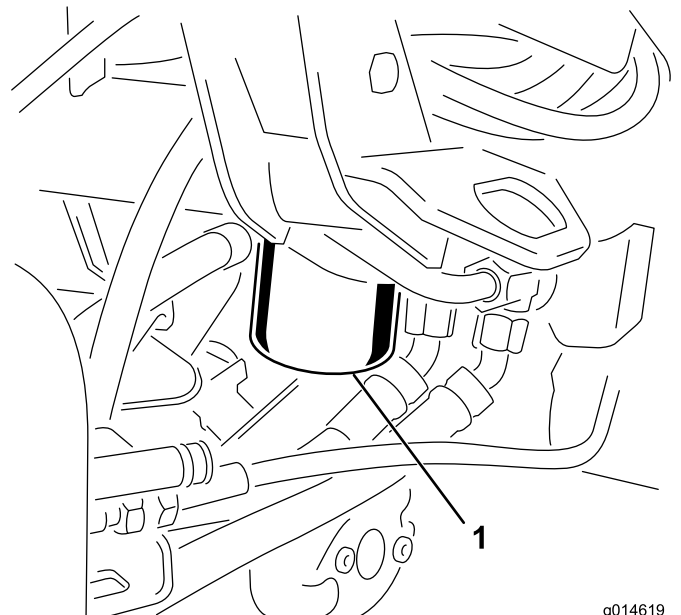

g014619

**Figure 50**

1. Hydraulic oil filter

2. Fill the replacement filter with the appropriate hydraulic fluid, lubricate the sealing gasket, and hand turn it until the gasket contacts the filter head. Then tighten 3/4 turn further. The filter should now be sealed.
3. Fill the hydraulic reservoir with hydraulic oil; refer to Checking the Hydraulic Fluid Level (page 26).
4. Start the machine and run it at idle for 3 to 5 minutes to circulate the fluid and remove any air trapped in the system.
5. Stop the machine, recheck the fluid level and replenish as required.
6. Dispose of the oil and filter properly.



## Checking the Hydraulic Lines and Hoses

### **⚠ WARNING**

Hydraulic fluid escaping under pressure can penetrate skin and cause injury.

- Make sure all hydraulic fluid hoses and lines are in good condition and all hydraulic connections and fittings are tight before applying pressure to the hydraulic system.
- Keep your body and hands away from pin hole leaks or nozzles that eject high pressure hydraulic fluid.
- Use cardboard or paper to find hydraulic leaks.
- Safely relieve all pressure in the hydraulic system before performing any work on the hydraulic system.
- Get immediate medical help if fluid is injected into skin.

Check the hydraulic lines and hoses daily for leaks, kinked lines, loose mounting supports, wear, loose fittings, weather deterioration, and chemical deterioration. Make all necessary repairs before operating.

## Cutting Unit Maintenance

### Backlapping the Reels

### **⚠ WARNING**

Contact with the reels or other moving parts can result in personal injury.

- Keep fingers, hands, and clothing away from the reels or other moving parts.
  - Never attempt to turn the reels by hand or foot while the engine is running.
1. Position the machine on a level surface, lower the cutting units, stop the engine, engage the parking brake.
  2. Remove the plastic cover to the left side of the seat.
  3. Make initial reel to bedknife adjustments appropriate for backlapping on all cutting units which are to be backlapped; refer to the *Cutting Unit Operator's Manual*.
  4. Start the engine and run at low idle speed. If the engine stalls, increase the engine speed.
  5. Switch the Backlap Switch to the reverse (R) position (Figure 51).

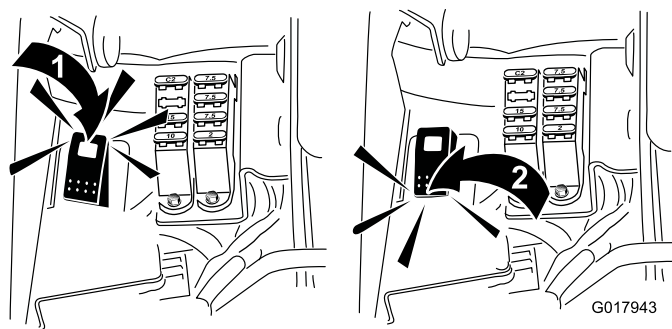

**Figure 51**

1. Backlap switch—backlap position
2. Backlap switch—mow position

6. On the InfoCenter pull up the Main Menu and scroll down to Settings.
7. In the Settings menu scroll down to Backlap RPM and use the  $\pm$  button to select the desired backlap speed.
8. With the functional control lever in the neutral position, move the Raise/Lower Mow control forward to start the backlapping operation on the designated reels.
9. Apply lapping compound with a long handle brush. Never use a short handled brush.
10. If the reels stall or become erratic while backlapping, select a higher reel speed setting until the speed stabilizes.
11. To make an adjustment to the cutting units while backlapping, turn the reels off by moving the Raise/Lower Mow control rearward and stop the

engine. After completing adjustments, repeat steps 4 through 9.

12. Repeat the procedure for all cutting units you want to backlap.
13. When finished, return the Backlap Switch to the forward (F) position, replace the cover, and wash all the lapping compound off of the cutting units. Adjust the cutting unit reel to bedknife as needed. Move the cutting unit reel speed control to the desired mowing position.

**Important:** If the backlap switch is not returned to the forward (F) position after backlapping, the cutting units will not raise or function properly.

## Storage

If you wish to store the machine for a long period of time, the following steps should be performed prior to storage:

1. Remove accumulations of dirt and old grass clippings. Sharpen the reels and bedknives, if necessary; refer to the *Cutting Unit Operator's Manual*. Use a rust preventive on bedknives and reel blades. Grease and oil all lubrication points; refer to Lubrication.
2. Block up the wheels to remove any weight on the tires.
3. Drain and replace the hydraulic fluid and filter and inspect the hydraulic lines and fittings. Replace, if necessary; refer to Changing the Hydraulic Oil and Filter and Checking the Hydraulic Lines and Hoses.
4. All fuel should be removed from the fuel tank. Run the engine until it stops from lack of fuel. Replace the fuel filter; refer to Replacing the Fuel Filter.
5. While the engine is still warm, drain the oil from the crankcase. Refill it with fresh oil; refer to Changing the Engine Oil and Filter.
6. Remove the spark plugs, pour one ounce of SAE 30 oil into the cylinders, and crank slowly to distribute the oil. Replace the spark plugs; refer to Replacing the Spark Plugs.
7. Clean dirt and chaff from the cylinder, cylinder head fins, and blower housing.
8. Remove the battery and charge it fully. Either store it on the shelf or on the machine. Leave the cables disconnected if it is stored on the machine. Store the battery in a cool atmosphere to avoid quick deterioration of the charge in the battery.
9. If possible, store the machine in a warm, dry location.

# Schematics

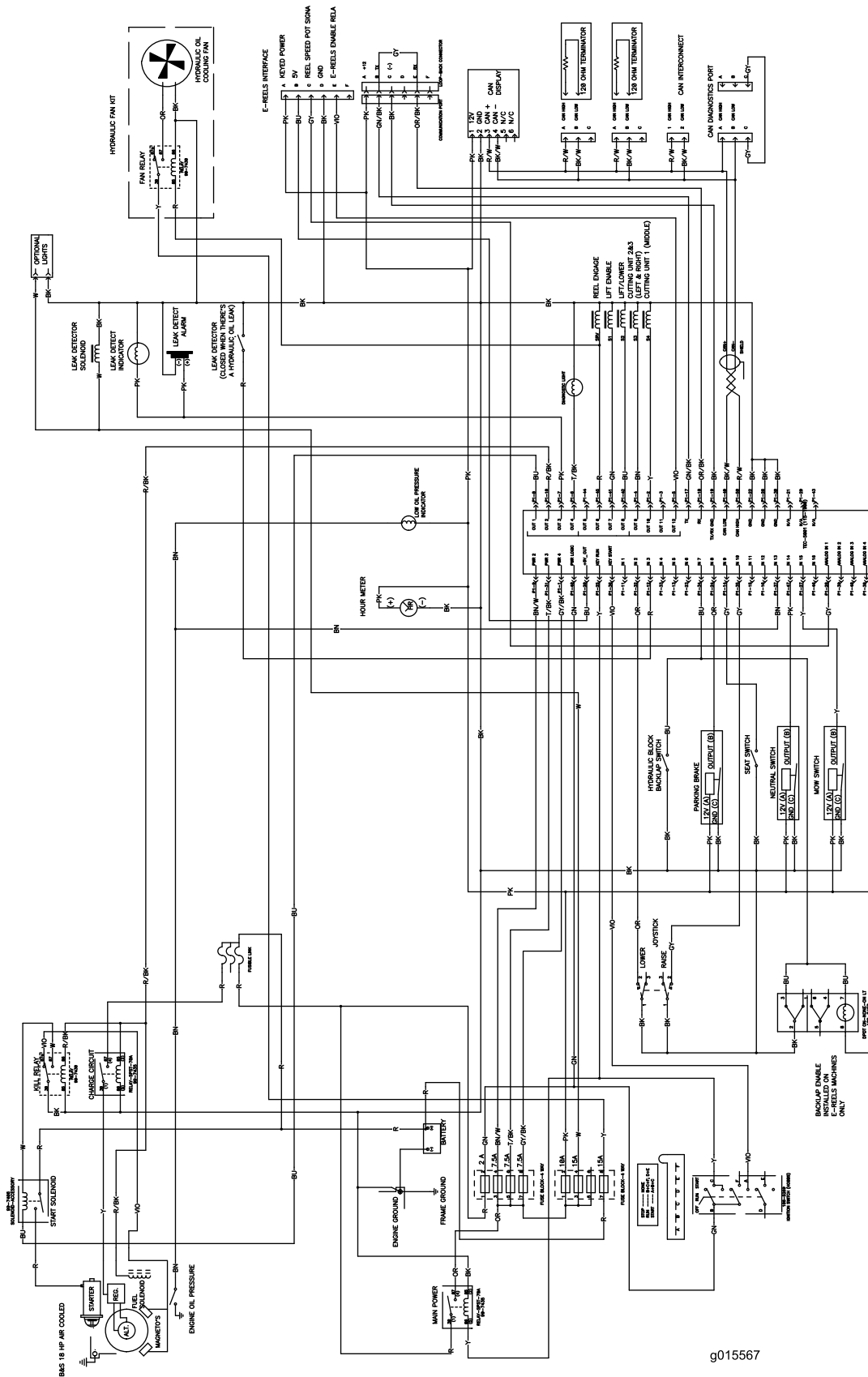

g015567

Electrical Schematic (Note: the optional Leak Detector Kit is included in this schematic) (Rev. A)

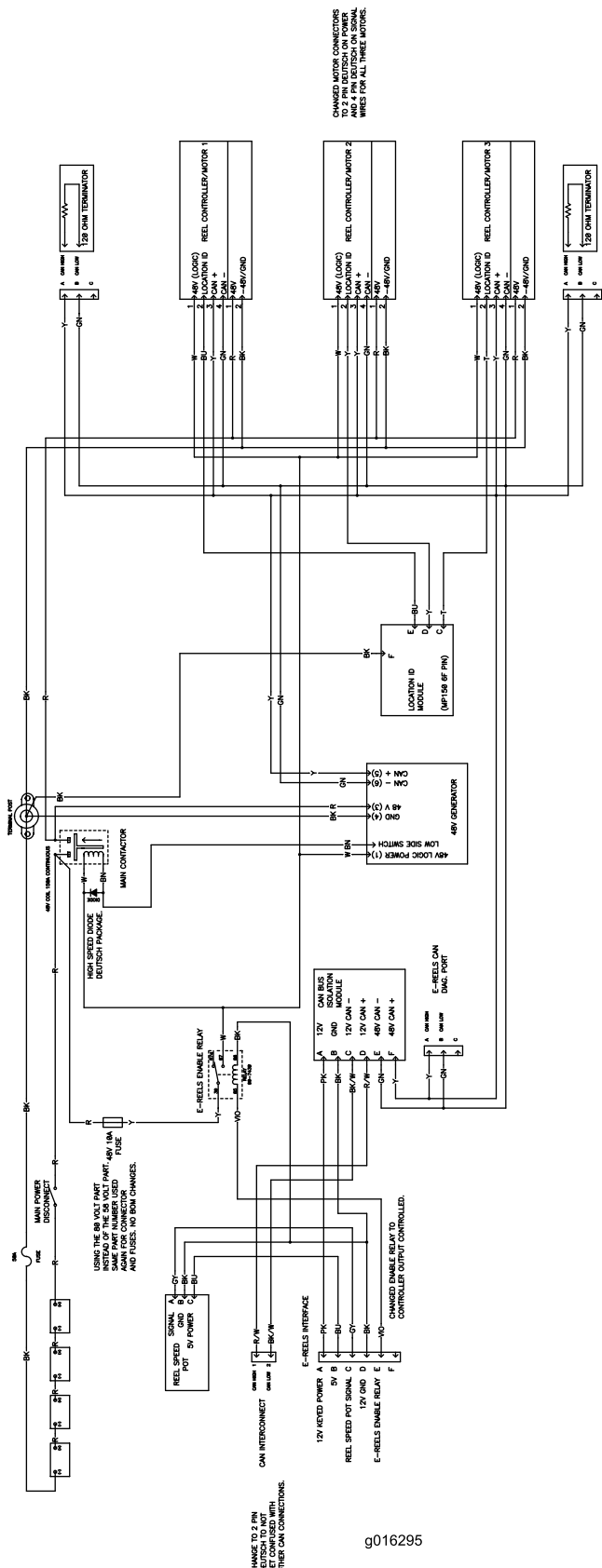

CHANGED WIRE CONNECTIONS TO 2 PIN DEUTSCH ON POWER AND 2 PIN DEUTSCH ON SIGNAL WIRE 2 PIN FULL THREE WIRE.

USING THE 50 VOLT PART INSTEAD OF THE 25 VOLT PART. 48V 15A FUSE. MAIN FUSE CHANGES USED AND FUSES. NO ION CHANGES.

CHANGE TO 2 PIN GET DOWNLOAD WITH OTHER CAN CONNECTIONS.

g016295

### Electrical Schematic—Cutting Units (Rev. A)

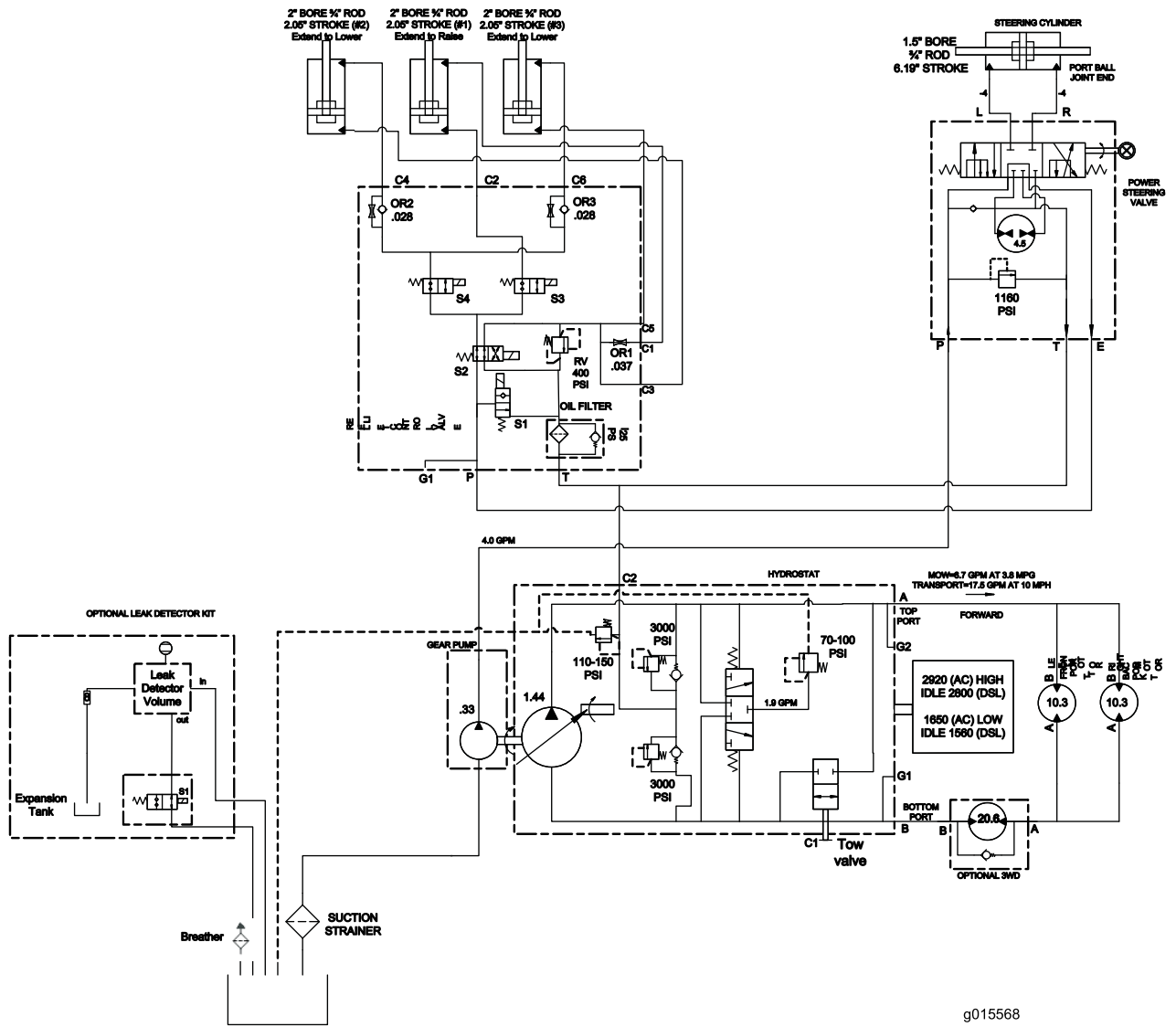

Hydraulic Schematic (Rev. A)

g015568

# Notes:

**Notes:**



# The Toro Total Coverage Guarantee

## A Limited Warranty

### Conditions and Products Covered

The Toro® Company and its affiliate, Toro Warranty Company, pursuant to an agreement between them, jointly warrant your Toro Commercial product ("Product") to be free from defects in materials or workmanship for two years or 1500 operational hours\*, whichever occurs first. This warranty is applicable to all products with the exception of Aerators (refer to separate warranty statements for these products). Where a warrantable condition exists, we will repair the Product at no cost to you including diagnostics, labor, parts, and transportation. This warranty begins on the date the Product is delivered to the original retail purchaser.

\* Product equipped with an hour meter.

### Instructions for Obtaining Warranty Service

You are responsible for notifying the Commercial Products Distributor or Authorized Commercial Products Dealer from whom you purchased the Product as soon as you believe a warrantable condition exists. If you need help locating a Commercial Products Distributor or Authorized Dealer, or if you have questions regarding your warranty rights or responsibilities, you may contact us at:

Commercial Products Service Department  
Toro Warranty Company  
8111 Lyndale Avenue South  
Bloomington, MN 55420-1196  
E-mail: commercial.warranty@toro.com

### Owner Responsibilities

As the Product owner, you are responsible for required maintenance and adjustments stated in your Operator's Manual. Failure to perform required maintenance and adjustments can be grounds for disallowing a warranty claim.

### Items and Conditions Not Covered

Not all product failures or malfunctions that occur during the warranty period are defects in materials or workmanship. This warranty does not cover the following:

- Product failures which result from the use of non-Toro replacement parts, or from installation and use of add-on, or modified non-Toro branded accessories and products. A separate warranty may be provided by the manufacturer of these items.
- Product failures which result from failure to perform recommended maintenance and/or adjustments. Failure to properly maintain your Toro product per the Recommended Maintenance listed in the *Operator's Manual* can result in claims for warranty being denied.
- Product failures which result from operating the Product in an abusive, negligent or reckless manner.
- Parts subject to consumption through use unless found to be defective. Examples of parts which are consumed, or used up, during normal Product operation include, but are not limited to, brakes pads and linings, clutch linings, blades, reels, bed knives, tines, spark plugs, castor wheels, tires, filters, belts, and certain sprayer components such as diaphragms, nozzles, and check valves, etc.
- Failures caused by outside influence. Items considered to be outside influence include, but are not limited to, weather, storage practices,

contamination, use of unapproved coolants, lubricants, additives, fertilizers, water, or chemicals, etc.

- Normal noise, vibration, wear and tear, and deterioration.
- Normal "wear and tear" includes, but is not limited to, damage to seats due to wear or abrasion, worn painted surfaces, scratched decals or windows, etc.

### Parts

Parts scheduled for replacement as required maintenance are warranted for the period of time up to the scheduled replacement time for that part. Parts replaced under this warranty are covered for the duration of the original product warranty and become the property of Toro. Toro will make the final decision whether to repair any existing part or assembly or replace it. Toro may use remanufactured parts for warranty repairs.

### Note Regarding Deep Cycle Battery Warranty:

Deep cycle batteries have a specified total number of kilowatt-hours they can deliver during their lifetime. Operating, recharging, and maintenance techniques can extend or reduce total battery life. As the batteries in this product are consumed, the amount of useful work between charging intervals will slowly decrease until the battery is completely worn out. Replacement of worn out batteries, due to normal consumption, is the responsibility of the product owner. Battery replacement may be required during the normal product warranty period at owner's expense.

### Maintenance is at Owner's Expense

Engine tune-up, lubrication cleaning and polishing, replacement of Items and Conditions Not Covered filters, coolant, and completing Recommended Maintenance are some of the normal services Toro products require that are at the owner's expense.

### General Conditions

Repair by an Authorized Toro Distributor or Dealer is your sole remedy under this warranty.

**Neither The Toro Company nor Toro Warranty Company is liable for indirect, incidental or consequential damages in connection with the use of the Toro Products covered by this warranty, including any cost or expense of providing substitute equipment or service during reasonable periods of malfunction or non-use pending completion of repairs under this warranty. Except for the Emissions warranty referenced below, if applicable, there is no other express warranty.**

All implied warranties of merchantability and fitness for use are limited to the duration of this express warranty. Some states do not allow exclusions of incidental or consequential damages, or limitations on how long an implied warranty lasts, so the above exclusions and limitations may not apply to you.

This warranty gives you specific legal rights, and you may also have other rights which vary from state to state.

### Countries Other than the United States or Canada

Customers should contact their Toro Distributor (Dealer) to obtain guarantee policies for your country, province, or state. If for any reason you are dissatisfied with your Distributor's service or have difficulty obtaining guarantee information, contact the Toro importer. If all other remedies fail, you may contact us at Toro Warranty Company.