



**Count on it.**

**Operator's Manual**

**TimeCutter® SS 3200 Riding Mower**

Model No. 74621—Serial No. 31200001 and Up

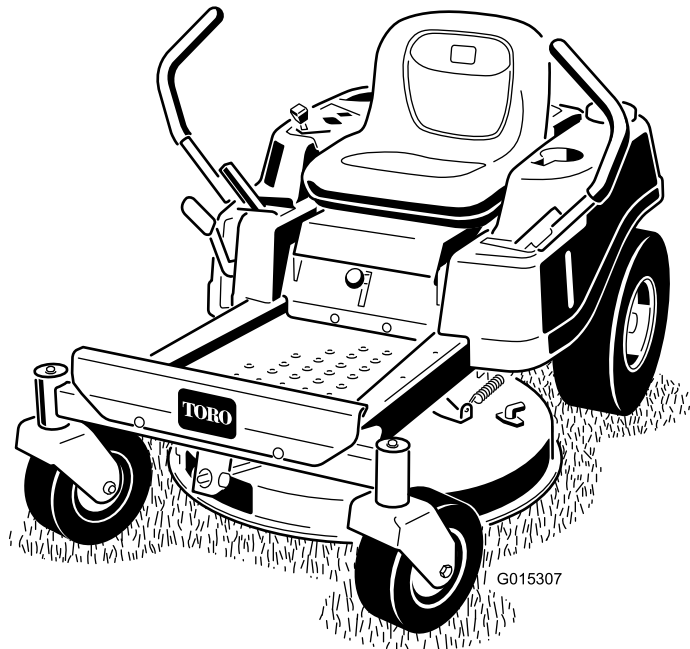

This machine is a ride-on, rotary-blade lawnmower intended to be used by homeowners in residential applications. It is primarily designed for cutting grass on well-maintained lawns. It is not designed for cutting brush, mowing grass and other growth alongside highways, or for agricultural uses.

## WARNING

### CALIFORNIA Proposition 65 Warning

The engine exhaust from this product contains chemicals known to the State of California to cause cancer, birth defects, or other reproductive harm.

**Important:** This engine is not equipped with a spark arrester muffler. It is a violation of California Public Resource Code Section 4442 to use or operate the engine on any forest-covered, brush-covered, or grass-covered land. Other states or federal areas may have similar laws.

This spark ignition system complies with Canadian ICES-002.

## ▲ WARNING

Removing standard original equipment parts and accessories may alter the warranty, traction, and safety of the machine. Failure to use original Toro parts could cause serious injury or death. Making unauthorized changes to the engine, fuel or venting system, may violate EPA and CARB regulations.

Replace all parts including, but not limited to, tires, belts, blades, and fuel system components with original Toro parts.

### Gross Horsepower

The gross or net horsepower of this engine was laboratory rated by the engine manufacturer in accordance with the Society of Automotive Engineers (SAE) J1940. As configured to meet safety, emission, and operating requirements, the actual engine torque on this class of mower will be significantly lower.

Go to [www.Toro.com](http://www.Toro.com) to view specifications on your mower model.

# Introduction

Read this information carefully to learn how to operate and maintain your product properly and to avoid injury and product damage. You are responsible for operating the product properly and safely.

You may contact Toro directly at [www.Toro.com](http://www.Toro.com) for product and accessory information, help finding a dealer, or to register your product.

Whenever you need service, genuine Toro parts, or additional information, contact an Authorized Service Dealer or Toro Customer Service and have the model and serial numbers of your product ready. Figure 1 identifies the location of the model and serial numbers on the product. Write the numbers in the space provided.

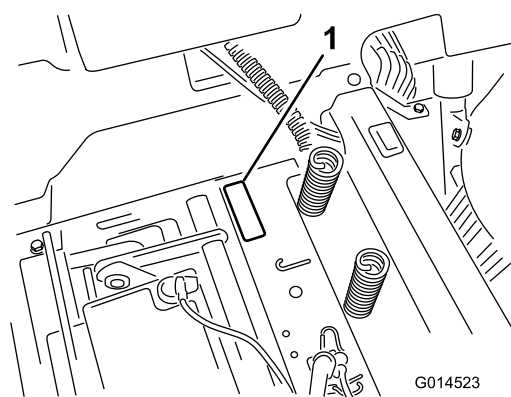

Figure 1  
Under the seat

1. Model and serial number plate

Write the product model and serial numbers in the space below:

Model No. _____
Serial No. _____

This manual identifies potential hazards and has safety messages identified by the safety alert symbol (Figure 2), which signals a hazard that may cause serious injury or death if you do not follow the recommended precautions.



Figure 2

1. Safety alert symbol.

This manual uses two other words to highlight information. **Important** calls attention to special mechanical information and **Note** emphasizes general information worthy of special attention.

# Contents

Introduction.....	2	Mower Maintenance.....	33
Safety.....	4	Servicing the Cutting Blades.....	33
Safe Operating Practices.....	4	Leveling the Mower Deck.....	36
Toro Riding Mower Safety.....	6	Removing the Mower.....	38
Slope Indicator.....	7	Mower Belt Maintenance.....	38
Safety and Instructional Decals.....	8	Installing the Mower.....	39
Product Overview.....	11	Replacing the Grass Deflector.....	39
Controls.....	11	Cleaning.....	40
Operation.....	13	Washing the Underside of the Mower.....	40
Think Safety First.....	13	Storage.....	41
Before Starting.....	14	Cleaning and Storage.....	41
Starting the Engine.....	15	Troubleshooting.....	43
Operating the Blades.....	16	Schematics.....	45
Testing the Safety Interlock System.....	17		
Stopping the Engine.....	17		
Driving.....	17		
Stopping the Machine.....	19		
Adjusting the Height of Cut.....	19		
Positioning the Seat.....	19		
Adjusting the Motion Control Levers.....	20		
Pushing the Machine by Hand.....	20		
Grass Deflector.....	21		
Operating Tips.....	21		
Maintenance.....	23		
Recommended Maintenance Schedule(s).....	23		
Premaintenance Procedures.....	23		
Raising the Seat.....	23		
Lubrication.....	24		
Greasing the Bearings.....	24		
Engine Maintenance.....	25		
Servicing the Air Cleaner.....	25		
Servicing the Engine Oil.....	26		
Servicing the Spark Plug.....	27		
Fuel System Maintenance.....	29		
Replacing the In-line Fuel Filter.....	29		
Electrical System Maintenance.....	30		
Charging the Battery.....	30		
Servicing the Fuses.....	31		
Drive System Maintenance.....	32		
Checking the Tire Pressure.....	32		
Releasing the Electric Brake.....	32		
Cooling System Maintenance.....	33		
Cleaning the Engine Screen.....	33		
Cleaning the Engine Cooling Fins and Shrouds.....	33		

# Safety

**This machine meets or exceeds the B71.1-2003 specifications of the American National Standards Institute, in effect at the time of production. However, improper use or maintenance by the operator or owner can result in injury. To reduce the potential for injury, comply with these safety instructions and always pay attention to the safety alert symbol, which means CAUTION, WARNING, or DANGER-"personal safety instruction." Failure to comply with the instruction may result in personal injury or death.**

## Safe Operating Practices

This product is capable of amputating hands and feet and throwing objects. Always follow all safety instructions to avoid serious injury or death.

The following instructions are from ANSI standard B71.1-2003. All the language within this ANSI standard applies to this machine; however, due to the application of the standard across many different types of products some statements can seem general or misleading. In these instances, Toro has refined the statement to convey the meaning of the standard while better matching the product this *Operator's Manual* pertains. Safety information in addition to the instructions found in the ANSI standard below can be found in Toro Riding Mower Safety at the end of this section.

## General Operation

- Read, understand, and follow all instructions in the operator's manual and on the machine before starting.
- Do not place hands or feet near rotating parts or under the machine. Keep clear of the discharge opening at all times.
- Allow only responsible adults who are familiar with the instructions to operate the machine.
- Clear the area of objects such as rocks, toys, wire, etc., which could be picked up and thrown by the blade.
- Be sure the area is clear of other people before mowing. Stop the machine if anyone enters the area.
- Never carry passengers.
- Do not mow in reverse unless absolutely necessary. Always look down and behind before and while backing up.
- Be aware of the mower discharge direction and do not point it at anyone. Avoid discharging material against a wall or obstruction. Material may ricochet

back toward the operator. Stop the blade(s) when crossing gravel surfaces.

- Do not operate the machine without deflector, discharge cover or entire grass collection system in place and working.
- Be alert, slow down and use caution when making turns. Look behind and to the side before changing directions.
- Never leave a running machine unattended. Always turn off blades, set parking brake, stop engine, and remove key before dismounting.
- Turn off blades when not mowing. Stop the engine, wait for all parts to come to a complete stop and remove the key before cleaning the machine, removing the grass catcher or unclogging the discharge chute.
- Operate the machine only in daylight or good artificial light.
- Do not operate the machine while under the influence of alcohol or drugs.
- Watch for traffic when operating near or crossing roadways.
- Use extra care when loading or unloading the machine into a trailer or truck.
- Always wear eye protection when operating the mower.
- Data indicates that operators, age 60 years and above, are involved in a large percentage of riding mower-related injuries. Operators should evaluate their ability to operate the riding mower safely enough to protect themselves and others from serious injury.
- Always follow the recommendations for any application of counterweights.
- Lightning can cause severe injury or death. If lightning is seen or thunder is heard in the area, do not operate the machine; seek shelter.

## Slope Operation

Slopes are a major factor related to loss of control and tip-over accidents, which can result in severe injury or death. Operation on all slopes requires extra caution. If you cannot back up the slope or if you feel uneasy on it, do not mow it.

- Do not mow slopes greater than 15 degrees.
- Watch for ditches, holes, rocks, dips, and rises that change the operating angle, as rough terrain could overturn the machine.

- Choose a low ground speed so you will not have to stop while operating on a slope.
- Do not mow slopes when grass is wet. Slippery conditions reduce traction and could cause sliding and loss of control.
- Always keep the drive wheels engaged when going down slopes.
- Reduce speed and use extreme caution on slopes.
- Do not make sudden turns or rapid speed changes.
- Remove or mark obstacles such as rocks, tree limbs, etc. from the mowing area. Tall grass can hide obstacles.
- Avoid sudden starts when mowing uphill because the mower may tip backwards.
- Be aware that loss of traction may occur going downhill. Weight transfer to the front wheels may cause drive wheels to slip and cause loss of braking and steering.
- Always avoid sudden starting or stopping on a slope. If tires lose traction, stop the machine, disengage the blades and proceed slowly off the slope.
- Use extreme care with grass catchers or other attachments. These can change the stability of the machine and cause loss of control.
- Do not try to stabilize the machine by putting your foot on the ground.
- Do not mow near drop-offs, ditches, steep banks or water. Wheels dropping over edges can cause rollovers, which may result in serious injury, death or drowning.
- Use a walk behind mower and/or a hand trimmer near drop-offs, ditches, steep banks or water.
- Children who have been given rides in the past may suddenly appear in the mowing area for another ride and be run over or backed over by the mower.
- Never allow children to operate the machine.
- Use extra care when approaching blind corners, shrubs, trees, the end of a fence or other objects that may obscure vision.

## Towing

A hitch kit is available for this machine and can be obtained by contacting an Authorized Toro Dealer. Do not tow without first installing this manufacturer approved hitch. The following guidelines apply when towing with the approved hitch kit installed.

- Tow only with a machine that has a hitch designed for towing. Do not attach towed equipment except at the hitch point.
- Follow the manufacturer's recommendation for weight limits for towed equipment and towing on slopes.
- Never allow children or others in or on towed equipment.
- On slopes, the weight of the towed equipment may cause loss of traction and loss of control.
- Travel slowly and allow extra distance to stop.

## Service

Safe Handling of Gasoline:

To avoid personal injury or property damage, use extra care when handling gasoline and other fuels. They are flammable and the vapors are explosive.

- Extinguish all cigarettes, cigars, pipes and other sources of ignition.
- Use only an approved container.
- Never remove the gas cap or add fuel when the engine is running. Allow the engine to cool before refueling.
- Never refuel the machine indoors.
- Never store the machine or fuel container inside where there is an open flame, such as near a water heater or furnace.
- Never fill containers inside a vehicle or on a truck or trailer with a plastic liner. Always place containers on the ground away from your vehicle before filling.
- Remove gas-powered equipment from the truck or trailer and refuel it on the ground. If this is not possible, then refuel such equipment with a portable

## Children

Tragic accidents can occur if the operator is not alert to the presence of children. Children are often attracted to the machine and the mowing activity. Never assume that children will remain where you last saw them.

- Keep children out of the mowing area and under the watchful care of another responsible adult, not the operator.
- Be alert and turn the machine off if children enter the area.
- Before and while backing or changing direction, look behind, down, and side-to-side for small children.
- Never carry children, even with the blades off. They may fall off and be seriously injured or interfere with safe machine operation.

container, rather than from a gasoline dispenser nozzle.

- Keep the nozzle in contact with the rim of the fuel tank or container opening at all times until the fueling is complete. Do not use a nozzle lock-open device.
- If fuel is spilled on clothing, change clothing immediately.
- Never overfill the fuel tank. Replace gas cap and tighten securely.

#### General Service:

- Never operate a machine inside a closed area. Engine exhaust contains carbon monoxide, which is an odorless, deadly poison that can kill you.
- Keep nuts and bolts tight, especially the blade attachment bolts. Keep equipment in good condition.
- Never tamper with safety devices. Check their proper operation regularly.
- Keep the machine free of grass, leaves, or other debris build-up. Clean up oil or fuel spillage fuel soaked debris. Allow the machine to cool before storing.
- Stop and inspect the equipment if you strike an object. Repair, if necessary, before restarting.
- Never make any adjustments or repairs with the engine running.
- Grass catcher components are subject to wear, damage and deterioration, which could expose moving parts or allow objects to be thrown. Frequently check components and replace with manufacturers' recommended parts, when necessary.
- Mower blades are sharp and can cut. Wrap the blade(s) or wear gloves, and use extra caution when servicing them.
- Check for proper brake operation frequently. Adjust and service as required.
- Maintain or replace safety and instruction decals as necessary.
- Use only genuine Toro replacement parts to ensure that original standards are maintained.

the blade control switch, remove the key and disconnect the spark plug wire(s) before performing any service, repairs, maintenance or adjustments.

- Keep hands, feet, hair, and loose clothing away from attachment discharge area, underside of mower and any moving parts while engine is running.
- Do not touch equipment or attachment parts which may be hot from operation. Allow to cool before attempting to maintain, adjust or service.
- Battery acid is poisonous and can cause burns. Avoid contact with skin, eyes, and clothing. Protect your face, eyes, and clothing when working with a battery.
- Battery gases can explode. Keep cigarettes, sparks and flames away from battery.
- Use only Toro approved attachments. Warranty may be voided if used with unapproved attachments.
- If loading the machine onto a trailer or truck, use a single, full-width ramp only. The ramp angle should not exceed 15 degrees.

## Toro Riding Mower Safety

The following list contains safety information specific to Toro products or other safety information that you must know that may not be included in the ANSI standards.

- Stop the engine, move the motion control levers to neutral and outward to the park position, disengage

# Slope Indicator



2

G011841

Figure 3

This page may be copied for personal use.

1. The maximum slope you can safely operate the machine on is **15 degrees**. Use the slope chart to determine the degree of slope of hills before operating. **Do not operate this machine on a slope greater than 15 degrees**. Fold along the appropriate line to match the recommended slope.
2. Align this edge with a vertical surface, a tree, building, fence pole, etc.
3. Example of how to compare slope with folded edge.

# Safety and Instructional Decals



Safety decals and instructions are easily visible to the operator and are located near any area of potential danger. Replace any decal that is damaged or lost.

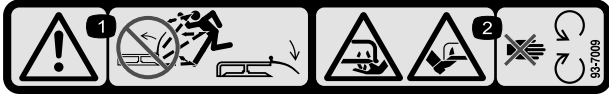

93-7009

1. Warning—don't operate the mower with the deflector up or removed; keep the deflector in place.
2. Cutting/dismemberment hazard of hand or foot, mower blade—stay away from moving parts.

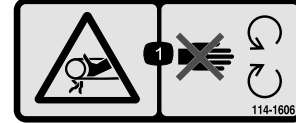

114-1606

1. Entanglement hazard, belt—keep all guards in place.

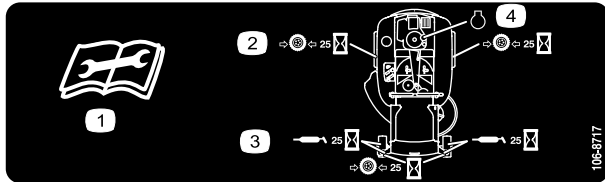

106-8717

1. Read the instructions before servicing or performing maintenance.
2. Check tire pressure every 25 operating hours.
3. Grease every 25 operating hours.
4. Engine



Manufacturer's Mark

1. Indicates the blade is identified as a part from the original machine manufacturer.

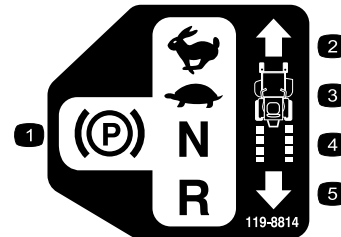

119-8814

- |                     |            |
|---------------------|------------|
| 1. Parking position | 4. Neutral |
| 2. Fast             | 5. Reverse |
| 3. Slow             |            |

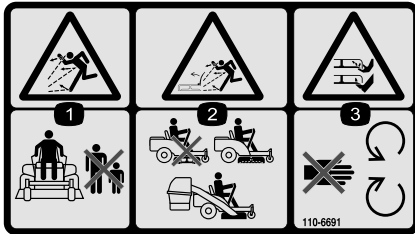

110-6691

1. Thrown object hazard—keep bystanders a safe distance from the machine.
2. Thrown object hazard, mower—do not operate without the deflector, discharge cover, or grass collection system in place.
3. Cutting/dismemberment of hand or foot—stay away from moving parts.

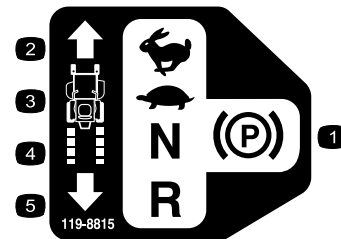

119-8815

- |                     |            |
|---------------------|------------|
| 1. Parking position | 4. Neutral |
| 2. Fast             | 5. Reverse |
| 3. Slow             |            |



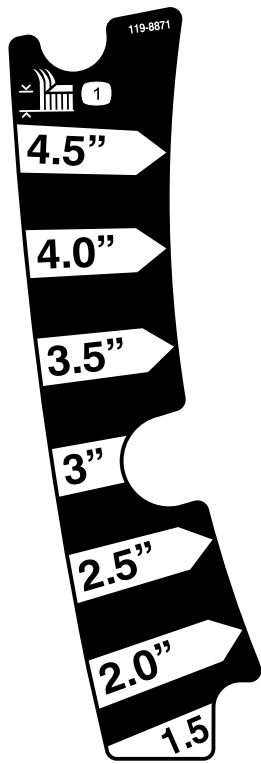

119-8871

1. Height-of-cut



**Battery Symbols**

Some or all of these symbols are on your battery

- |  |  |
|--|--|
| 1. Explosion hazard                    | 6. Keep bystanders a safe distance from the battery.                           |
| 2. No fire, open flame, or smoking.    | 7. Wear eye protection; explosive gases can cause blindness and other injuries |
| 3. Caustic liquid/chemical burn hazard | 8. Battery acid can cause blindness or severe burns.                           |
| 4. Wear eye protection                 | 9. Flush eyes immediately with water and get medical help fast.                |
| 5. Read the <i>Operator's Manual</i> . | 10. Contains lead; do not discard.   |



121-2989

- |  |  |
|--|--|
| 1. Bypass lever position for pushing the machine | 2. Bypass lever position for operating the machine |
|--|--|

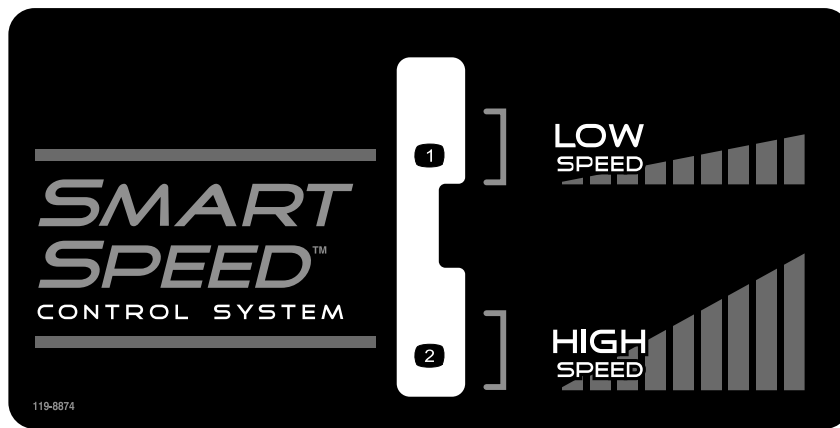

119-8874

1. Low speed

2. High speed

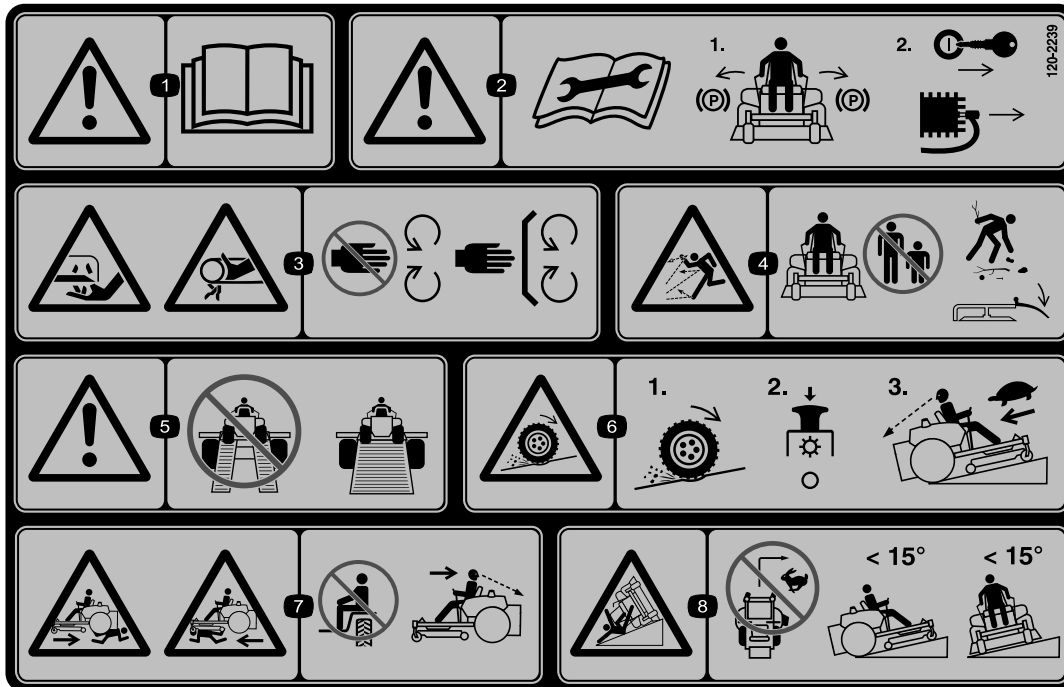

120-2239

1. Warning—read the *Operator's Manual*.
2. Warning—read the instructions before servicing or performing maintenance; move the motion control levers to the park (brake) position, remove the ignition key and disconnect the spark plug wire.
3. Cutting/dismemberment hazard, mower blade; entanglement hazard, belt—stay away from moving parts, keep all guards and shields in place.
4. Thrown object hazard—keep bystanders a safe distance from the machine, pick up debris before operating, keep deflector in place.
5. Warning—do not use split ramps, use a full ramps when transporting machine.
6. Loss of traction/control hazard, slopes—loss of traction/control on a slope, disengage the blade control switch (PTO), proceed off the slope slowly.
7. Crushing/dismemberment hazard of bystanders, reversing; crushing/dismemberment hazard of bystanders—do not carry passengers, look behind and down when reversing.
8. Tipping hazard—do not mow slopes greater than 15 degrees, avoid sudden and sharp turns while on slopes.

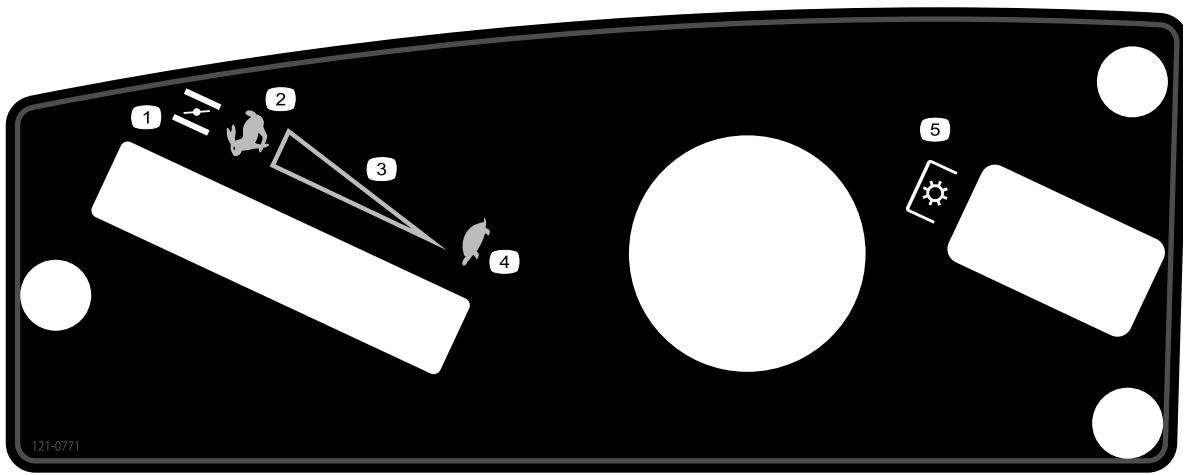

121-0771

- |                                |   |
|--------------------------------|---|
| 1. Choke                       | 4. Slow                                       |
| 2. Fast                        | 5. Power take-off (PTO), Blade control switch |
| 3. Continuous variable setting |   |

## Product Overview

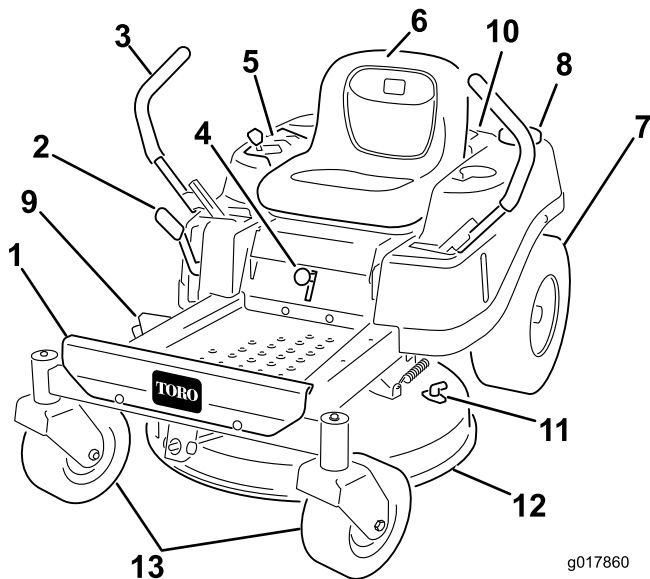
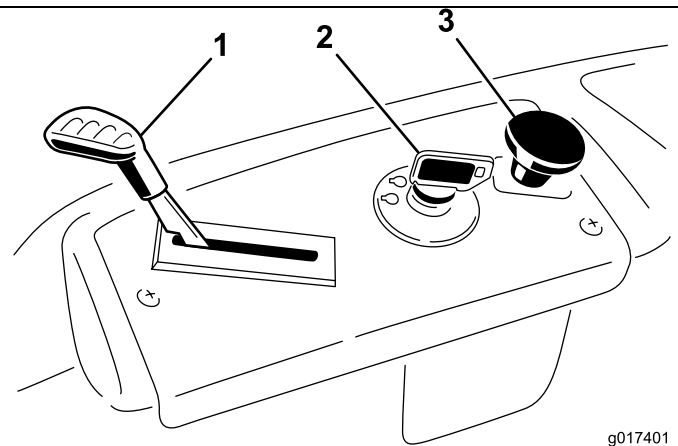

Figure 4

- |                          |                        |
|--------------------------|------------------------|
| 1. Footrest              | 8. Fuel tank cap       |
| 2. Height of cut lever   | 9. Deflector           |
| 3. Motion control levers | 10. Engine             |
| 4. Smart speed lever     | 11. Washout fitting    |
| 5. Control panel         | 12. Mower deck         |
| 6. Operator seat         | 13. Front caster wheel |
| 7. Rear drive wheel      |                        |

## Controls

Become familiar with all of the controls in Figure 4 and Figure 5 before you start the engine and operate the machine.



g017401

Figure 5  
Control Panel

- |                    |  |
|--------------------|--|
| 1. Throttle/Choke  | 3. Blade control switch (power take-off) |
| 2. Ignition switch |  |

## Ignition Switch

The ignition switch has three positions, Off, Run and Start. The key will turn to Start and move back to Run upon release. Turning the key to the Off position will stop the engine; however, always remove the key when leaving the machine to prevent someone from accidentally starting the engine (Figure 5).

## Throttle/Choke Control

The throttle and choke is combined into one control lever. The throttle controls the engine speed and it has a continuous variable setting from Slow to Fast. Engage the choke by moving the lever past the Fast setting until it stops (Figure 5).

## Blade Control Switch (Power Take-Off)

The blade control switch, represented by a power take-off (PTO) symbol, engages and disengages power to the mower blades (Figure 5).

## Motion Control Levers and Park Position

The motion control levers are speed sensitive controls of independent wheel motors. Moving a lever forward or backward turns the wheel on the same side forward or in reverse; wheel speed is proportional to the amount the lever is moved. Move the control levers outward from the center to the park position and exit the machine (Figure 16). Always position the motion control levers into the park position when you stop the machine or leave it unattended.

## Smart Speed™ Control System Lever

The Smart Speed™ Control System lever, located below the operating position, gives the operator a choice to drive the machine at two speed ranges, high and low (Figure 6).

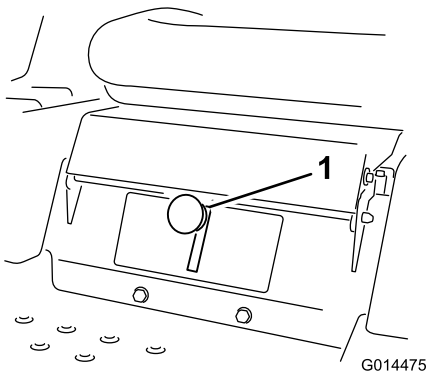
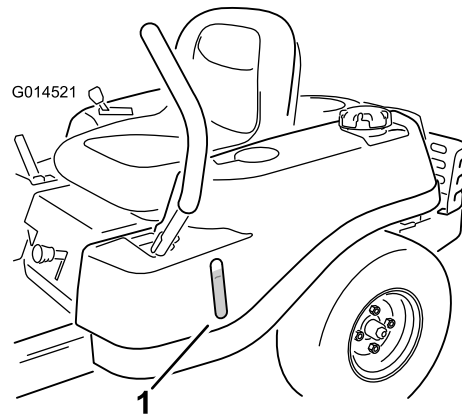

**Figure 6**

1. Smart speed lever

## Fuel Window

The fuel window located on the left hand side of the machine can be used to verify the presence of gasoline in the tank (Figure 7).



**Figure 7**

1. Fuel presence window

## Height-of-Cut Lever

The height of cut lever allows the operator to lower and raise the deck from the seated position. When the lever is moved up, toward the operator the deck is raised from the ground and when moved down, away from the operator it is lowered toward the ground. Only adjust the height of cut while machine is not moving (Figure 4).

# Operation

**Note:** Determine the left and right sides of the machine from the normal operating position.

## Think Safety First

### Operating Safety

Please carefully read all of the safety instructions and decals in the safety section. Knowing this information could help you, your family, pets or bystanders avoid injury.

#### **⚠ DANGER**

Mowing on wet grass or steep slopes can cause sliding and loss of control.

Wheels dropping over edges can cause rollovers, which may result in serious injury, death or drowning.

A loss of traction is a loss of steering control.

To avoid loss of control and possibility of rollover:

- Do not mow near drop-offs or near water.
- Do not mow slopes greater than 15 degrees.
- Reduce speed and use extreme caution on slopes.
- When mowing slopes, gradually work from lower to higher areas on the incline.
- Avoid sudden turns or rapid speed changes.
- Turn up, into an incline when changing directions on slopes. Turning down the slope reduces traction.
- Attachments change the handling characteristics of the machine. Use extra caution when using attachments with the machine.

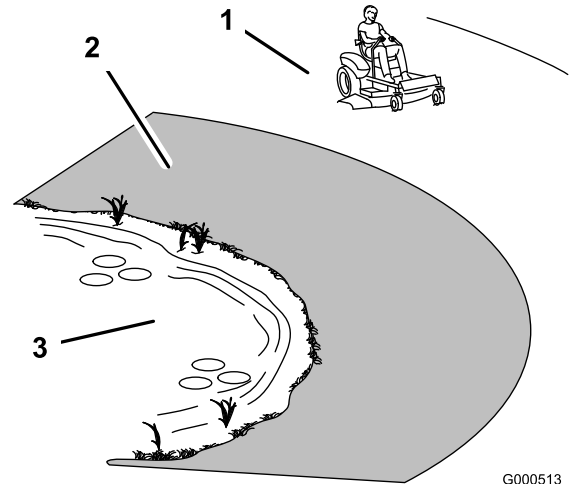

Figure 8

1. Safe Zone-use the TimeCutter here
2. Use walk behind mower and/or hand trimmer near drop-offs and water.
3. Water

### Fuel Safety

#### **⚠ DANGER**

In certain conditions, gasoline is extremely flammable and highly explosive. A fire or explosion from gasoline can burn you and others and can damage property.

- Fill the fuel tank outdoors, in an open area, when the engine is cold. Wipe up any gasoline that spills.
- Never fill the fuel tank inside an enclosed trailer.
- Do not fill the fuel tank completely full. Add gasoline to the fuel tank until the fuel reaches the base of the filler neck. This empty space in the tank allows gasoline to expand.
- Never smoke when handling gasoline, and stay away from an open flame or where gasoline fumes may be ignited by a spark.
- Store gasoline in an approved container and keep it out of the reach of children. Never buy more than a 30-day supply of gasoline.
- Do not operate without entire exhaust system in place and in proper working condition.

## **⚠ DANGER**

In certain conditions during fueling, static electricity can be released causing a spark which can ignite the gasoline vapors. A fire or explosion from gasoline can burn you and others and can damage property.

- Always place gasoline containers on the ground away from your vehicle before filling.
- Do not fill gasoline containers inside a vehicle or on a truck or trailer bed because interior carpets or plastic truck bed liners may insulate the container and slow the loss of any static charge.
- When practical, remove gas-powered equipment from the truck or trailer and refuel the equipment with its wheels on the ground.
- If this is not possible, then refuel such equipment on a truck or trailer from a portable container, rather than from a gasoline dispenser nozzle.
- If a gasoline dispenser nozzle must be used, keep the nozzle in contact with the rim of the fuel tank or container opening at all times until fueling is complete.

## **⚠ WARNING**

Gasoline is harmful or fatal if swallowed. Long-term exposure to vapors can cause serious injury and illness.

- Avoid prolonged breathing of vapors.
- Keep face away from nozzle and gas tank or conditioner opening.
- Keep gas away from eyes and skin.

## **Understanding the Safety Interlock System**

### **⚠ WARNING**

If safety interlock switches are disconnected or damaged the machine could operate unexpectedly causing personal injury.

- Do not tamper with the interlock switches.
- Check the operation of the interlock switches daily and replace any damaged switches before operating the machine.

The safety interlock system is designed to prevent the engine from starting unless:

- The blades are disengaged.
- The motion control levers are in the park position.

The safety interlock system also is designed to stop the engine whenever the control levers are out of the park position and you rise from the seat.

## **Before Starting**

### **Recommended Fuel**

- For best results, use only clean, fresh, unleaded gasoline with an octane rating of 87 or higher ((R+M)/2 rating method).
- Oxygenated fuel with up to 10% ethanol or 15% MTBE by volume is acceptable.
- **Do Not** use ethanol blends of gasoline (such as E15 or E85) with more than 10% ethanol by volume. Performance problems and/or engine damage may result which may not be covered under warranty.
- **Do Not** use gasoline containing methanol.
- **Do Not** store fuel either in the fuel tank or fuel containers over the winter unless a fuel stabilizer is used.
- **Do Not** add oil to gasoline.

### **Using Stabilizer/Conditioner**

Use a fuel stabilizer/conditioner in the machine to provide the following benefits:

- Keeps gasoline fresh during storage of 90 days or less. For longer storage it is recommended that the fuel tank be drained.
- Cleans the engine while it runs.
- Eliminates gum-like varnish buildup in the fuel system, which causes hard starting.

Add the correct amount of gas stabilizer/conditioner to the gas.

**Note:** A fuel stabilizer/conditioner is most effective when mixed with fresh gasoline. To minimize the chance of varnish deposits in the fuel system, use fuel stabilizer at all times.

## Filling the Fuel Tank

Make sure the engine is shut off and the motion controls are in the park position. Tank maximum capacity is 2.9 gallons.

**Important: Do Not overfill fuel tank. Fill the fuel tank to the bottom of the filler neck. The empty space in the tank allows the fuel to expand. Overfilling may result in fuel leakage or damage to the engine or emission system.**

1. Clean around the fuel tank cap and remove the cap.

**Note:** You can use the fuel window to verify the presence of gasoline before filling the tank (Figure 9).

2. **Slowly** add regular, unleaded gasoline until the fuel reaches the base of the filler neck (Figure 9).

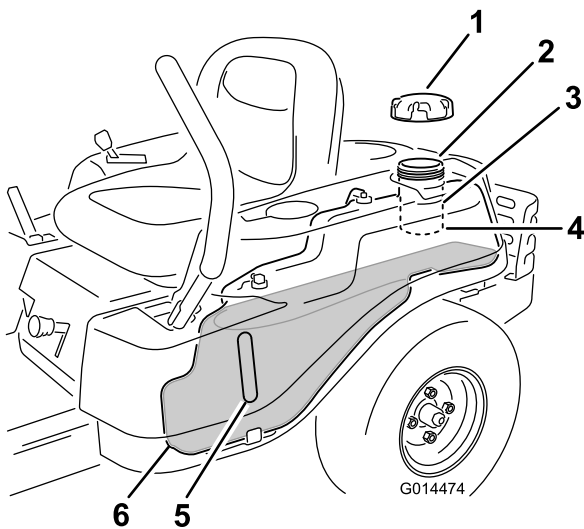

Figure 9

- |                  |  |
|------------------|--|
| 1. Fuel tank cap | 4. Base of filler neck, <b>DO NOT FILL PAST HERE</b> |
| 2. Fill opening  | 5. Fuel window                                       |
| 3. Filler neck   |  |

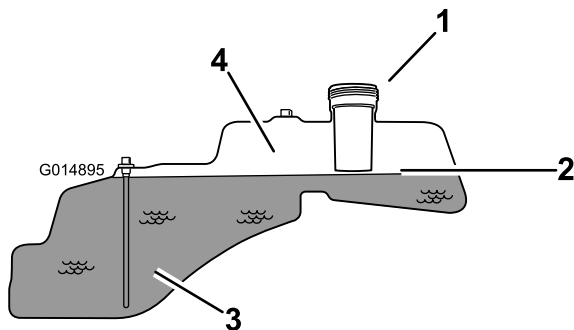

Figure 10

- |  |                                    |
|--|------------------------------------|
| 1. Fill opening                                      | 3. Fuel                            |
| 2. Base of filler neck, <b>DO NOT FILL PAST HERE</b> | 4. Empty space for fuel expansion. |

**Important: Do Not overfill fuel tank. Fill the fuel tank to the bottom of the filler neck. The empty space in the tank allows the fuel to expand. Overfilling may result in fuel leakage or damage to the engine or emission system.**

3. Install the fuel tank cap securely and tighten until it “clicks”. Wipe up any gasoline that may have spilled.

## Checking the Engine Oil Level

Before you start the engine and use the machine, check the oil level in the engine crankcase; refer to Checking the Oil Level in the Engine Maintenance section.

## Starting the Engine

1. Sit down on the seat and move the motion controls outward to the park position.
2. Disengage the blades by moving the blade control switch to Off (Figure 11).

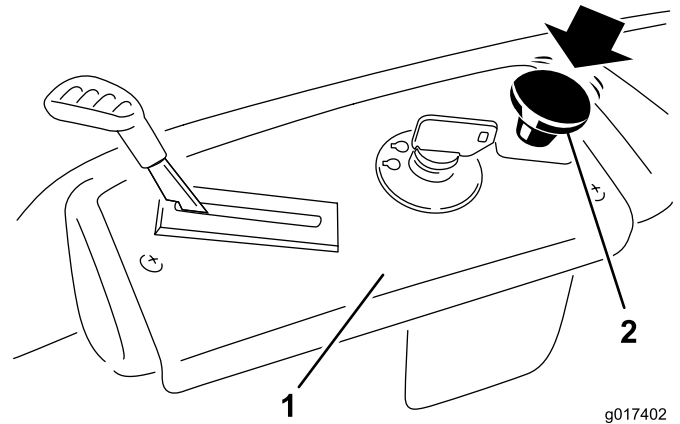

Figure 11

- |                  |                                      |
|------------------|--------------------------------------|
| 1. Control panel | 2. Blade control switch—Off position |
|------------------|--------------------------------------|

3. Move the throttle lever to Choke before starting a cold engine (Figure 12).

It may be necessary to hold the lever against the stop, in the choke position, while trying to start the engine.

**Note:** A warm or hot engine may not require choking.

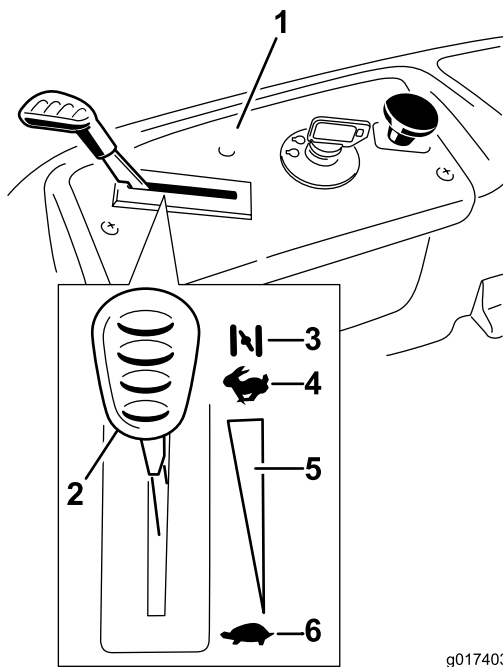

Figure 12

g017403

- |  |                                |
|--|--------------------------------|
| 1. Control panel                       | 4. Fast                        |
| 2. Throttle/choke lever—choke position | 5. Continuous variable setting |
| 3. Choke                               | 6. Slow                        |

- Turn the ignition key to Start to energize the starter. When the engine starts, release the key (Figure 13).

**Important:** Do not engage the starter for more than 10 seconds at a time. If the engine fails to start, allow a 60 second cool-down period between attempts. Failure to follow these instructions can damage the starter motor.

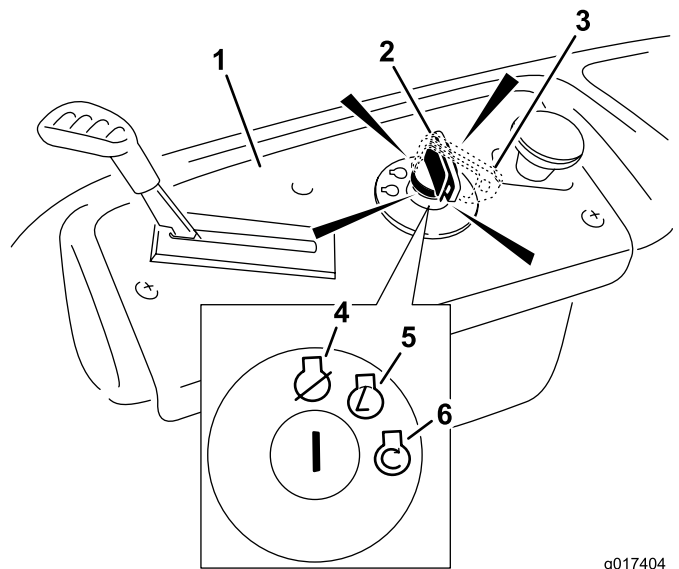

Figure 13

g017404

- |                                |          |
|--------------------------------|----------|
| 1. Control panel               | 4. Off   |
| 2. Ignition key—run position   | 5. Run   |
| 3. Ignition key—start position | 6. Start |

- After the engine starts, move the throttle lever to Fast (Figure 12). If the engine stalls or hesitates, move the throttle lever back to Choke for a few seconds. Repeat this as required.

## Operating the Blades

The blade control switch, represented by a power take-off (PTO) symbol, engages and disengages power to the mower blades. This switch controls power to any attachments that draw power from the engine, including the mower deck and cutting blades.

### Engaging the Blades

**Important:** Do not engage the blades when parked in tall grass. Belt or clutch damage can occur.

- Release pressure on the motion control levers and place the machine in neutral.
- Move the throttle to the Fast position.

**Note:** Always engage the blades with the throttle in the Fast position.

- Pull up on the blade control switch to move it to the On position and engage the blades (Figure 14).



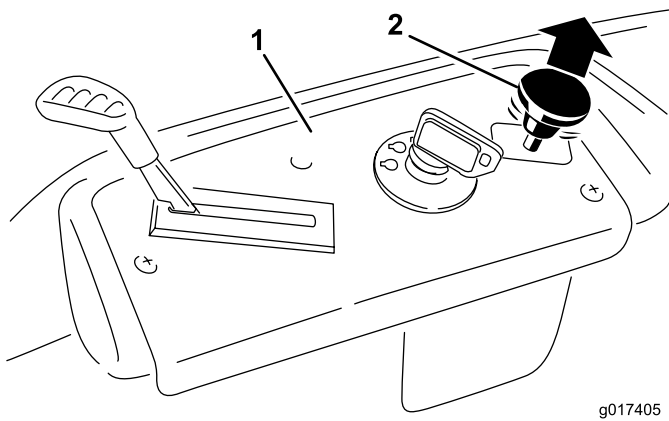

**Figure 14**

g017405

1. Control panel
2. Blade control switch—On position

## Disengaging the Blades

Push down on the blade control switch to move it to the Off position and disengage the blades (Figure 15).

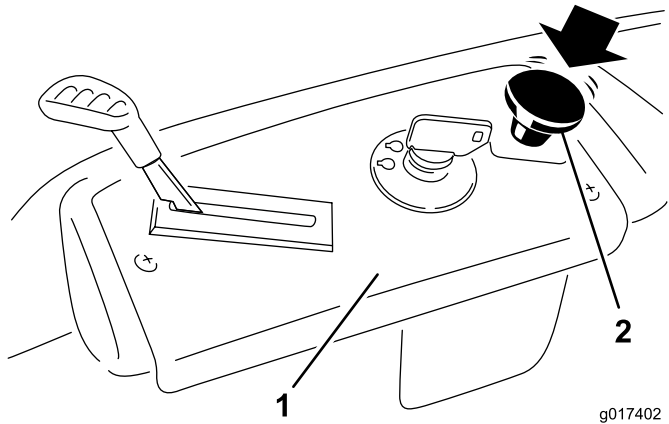

**Figure 15**

g017402

1. Control panel
2. Blade control switch—Off

## Testing the Safety Interlock System

Test the safety interlock system before you use the machine each time. If the safety system does not operate as described below, have an Authorized Service Dealer repair the safety system immediately.

1. While sitting on the seat, with the control levers in park position, and move the blade control switch to On. Try starting the engine; the engine should not crank.
2. While sitting on the seat, move the blade control switch to Off. Move either motion control lever to the center, unlocked position. Try starting the

engine; the engine should not crank. Repeat with the other motion control lever.

3. While sitting on the seat, move the blade control switch to Off, and lock the motion control levers in the park position. Start the engine. While the engine is running, engage the blade control switch, and rise slightly from the seat; the engine should stop.
4. While sitting on the seat, move the blade control switch to Off, and lock the motion control levers in the park position. Start the engine. While the engine is running, move the motion control levers to the center, unlocked position, engage the blade control switch, and rise slightly from the seat; the engine should stop.

## Stopping the Engine

1. Disengage the blades by moving the blade control switch to Off (Figure 15).
2. Move the throttle lever to Fast (Figure 13).
3. Turn the ignition key to Off (Figure 12) and remove the key.

## Driving

Driving the machine benefits from an understanding of what zero turn radius mower means. The drive wheels turn independently, powered by hydraulic motors on each axle; hence one side can turn in reverse while the other turns forward causing the machine to spin rather than turn. This vastly improves the machine maneuverability but may require some adjustment if the operator is unfamiliar.

### **⚠ WARNING**

**The machine can spin very rapidly. The operator may lose control of the machine and cause personal injury or damage to the machine.**

- Use caution when making turns.
- Slow the machine down before making sharp turns.

The throttle control regulates the engine speed as measured in rpm (revolutions per minute). Placing the throttle control in the Fast position can be best for performance. For most applications, operating in the full throttle position is desirable.

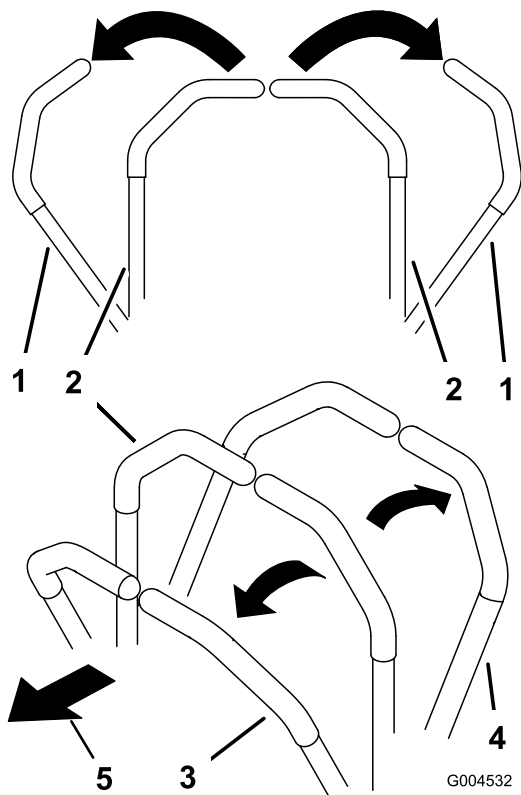
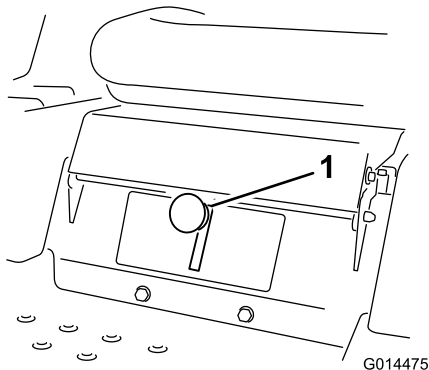

**Figure 16**

- |                           |                     |
|---------------------------|---------------------|
| 1. Park (brake) position  | 4. Backward         |
| 2. Center unlock position | 5. Front of machine |
| 3. Forward                |                     |

## Using the Smart Speed™ Control System

The Smart Speed™ Control System lever, located below the operating position (Figure 17), gives the operator a choice to drive the machine at two ground speed ranges, high and low.



**Figure 17**

1. Smart speed lever

To change speeds:

1. Move the motion control levers to neutral and outward to the park position; disengage the blade control switch.

### **⚠ WARNING**

Removing your hands from the motion control levers while the machine is in motion can result in a loss of control causing harm to you or bystanders.

Always stop the machine and move the motion control levers to the park position before adjusting the Smart Speed™ Control System.

2. Adjust the lever to the desired position.

## Forward

1. Move the levers to the center, unlocked position.
2. To go forward, slowly push the motion control levers forward (Figure 16).

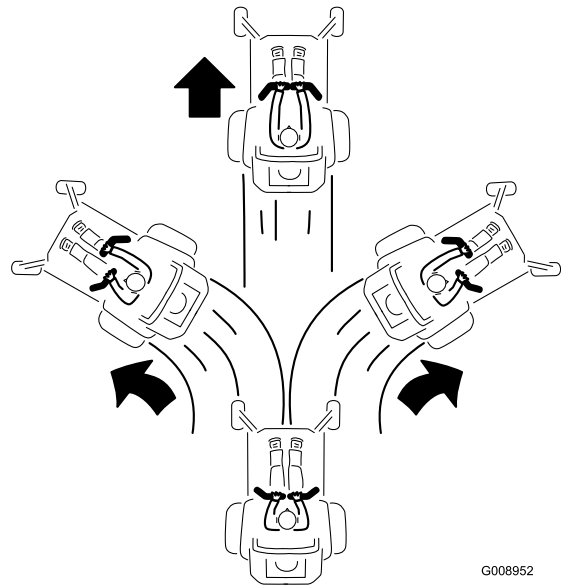

**Figure 18**

To go straight, apply equal pressure to both motion control levers (Figure 16).

To turn, release pressure on the motion control lever toward the direction you want to turn (Figure 16).

The farther you move the motion control levers in either direction, the faster the machine will move in that direction.

To stop, pull the motion control levers to neutral.

## Backward

1. Move the levers to the center, unlocked position.
2. To go backward, look behind you and down as you slowly pull the motion control levers rearward (Figure 19).

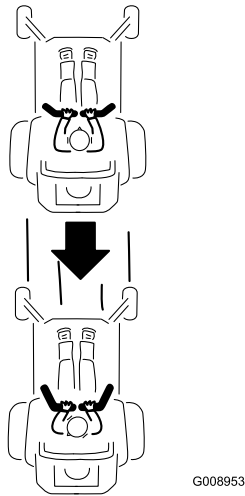

Figure 19

To go straight, apply equal pressure to both motion control levers (Figure 19).

To turn, release the pressure on the motion control lever toward the direction you want to turn.

To stop, push the motion control levers to neutral.

## Stopping the Machine

To stop the machine, move the motion control levers to neutral and outward to the park position, disengage the blade control switch, ensure the throttle is in the fast position, and turn the ignition key to off. Remember to remove the key from the ignition switch.

### **⚠ WARNING**

Children or bystanders may be injured if they move or attempt to operate the mower while it is unattended.

Always remove the ignition key and move the motion control levers outward to the park position when leaving the machine unattended, even if just for a few minutes.

## Adjusting the Height of Cut

Height-of-cut is controlled by the lever located to the right of the operating position (Figure 20).

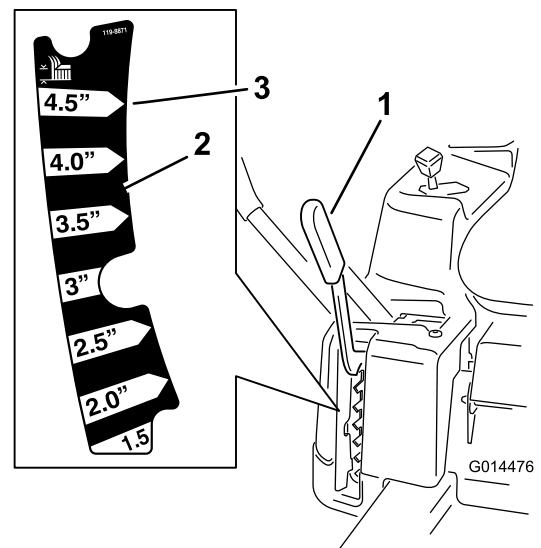

Figure 20

1. Height-of-cut lever
2. Height-of-cut positions
3. 4.5 inch (115 mm), Transport position

1. Pull up and inward on the lever to move it to the desired cutting position.
2. Once at the desired cutting position, slowly lower the lever until it engages the position.

The transport position is the highest height-of-cut position or cutting height 4.5 inch [115 mm] (Figure 20).

## Positioning the Seat

1. Raise the seat and loosen the adjustment bolts just enough that seat can move (Figure 21).

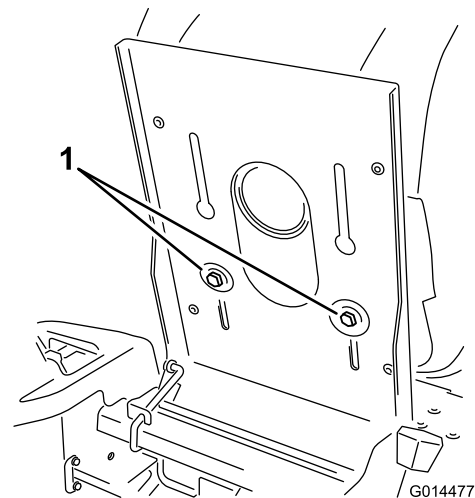

Figure 21

1. Adjustment bolt
2. Move the seat to the desired position and tighten the bolts.

# Adjusting the Motion Control Levers

## Adjusting the Height

The motion control levers can be adjusted higher or lower for maximum operator comfort.

1. Remove the 2 bolts holding the control lever to the control arm shaft (Figure 22).
2. Move the control lever to the next set of holes. Secure the lever with the 2 bolts (Figure 22).

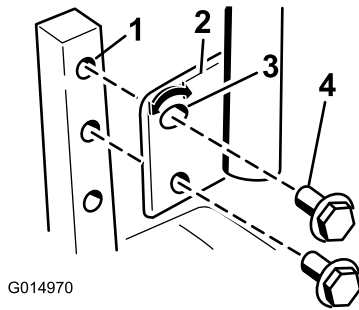

Figure 22

- |                      |                        |
|----------------------|------------------------|
| 1. Control arm shaft | 3. Slotted, upper hole |
| 2. Control lever     | 4. Bolt                |

3. Repeat the adjustment for the opposite control lever.

## Adjusting the Tilt

The motion control levers can be tilted fore or aft for maximum operator comfort.

1. Loosen the upper bolt holding the control lever to the control arm shaft.
2. Loosen the lower bolt just enough to pivot the control lever fore or aft (Figure 22). Tighten both bolts to secure the control in the new position.
3. Repeat the adjustment for the opposite control lever.

## Pushing the Machine by Hand

**Important:** Always push the machine by hand. Never tow the machine because damage may occur.

This machine has an electric brake mechanism and to push the machine the ignition key needs to be in the Run position. The battery needs to be charged and functioning for the electric brake to be disengage.

## To Push the Machine

1. Park the machine on a level surface and disengage the blade control switch.
2. Move the motion control levers outward to park position, stop the engine, and wait for all moving parts to stop before leaving the operating position.
3. Locate the bypass levers on the frame on both sides of the engine.
4. Move the bypass levers forward through the key hole and down to lock them in place as shown in Figure 23. Ensure this is done for each lever.
5. Move the motion control levers inward to the neutral position and turn the ignition key to the run position. Do not start the machine.

The machine is now able to be pushed by hand.

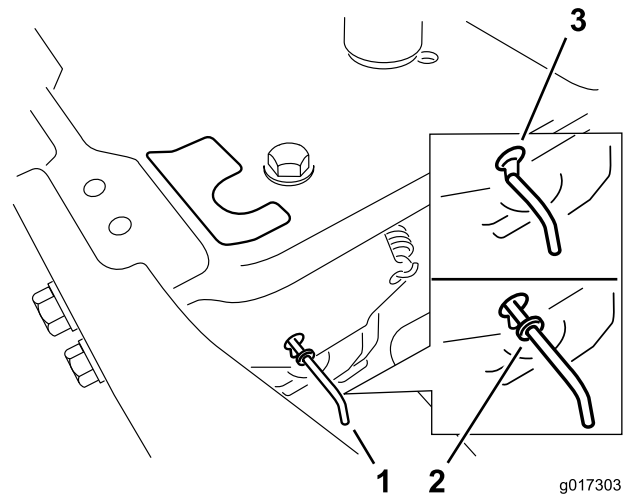

Figure 23

- |   |   |
|---|---|
| 1. Bypass lever locations                   | 3. Lever position for pushing the machine |
| 2. Lever position for operating the machine |   |

6. When finished, ensure the key has been returned to the Stop position to avoid draining the battery charge.

If the machine fails to move the electric brake may still be engaged. If necessary the electric brake can be released manually. Refer to the Releasing the Electric Brake (page 32) procedure in Drive Maintenance.

## To Operate the Machine

Move the bypass levers rearward through the key hole and down to lock them in place as shown (Figure 23). Ensure this is done for each lever.

## Grass Deflector

The mower has a hinged grass deflector that disperses clippings to the side and down toward the turf.

### **⚠ DANGER**

**Without the grass deflector, discharge cover, or complete grass catcher assembly mounted in place, you and others are exposed to blade contact and thrown debris. Contact with rotating mower blade(s) and thrown debris will cause injury or death.**

- Never remove the grass deflector from the mower because the grass deflector routes material down toward the turf. If the grass deflector is ever damaged, replace it immediately.
- Never put your hands or feet under the mower.
- Never try to clear discharge area or mower blades unless you move the blade control switch to Off and rotate the ignition key to Off. Also remove the key and pull the wire off the spark plug(s).

## Operating Tips

### Fast Throttle Setting

For best mowing and maximum air circulation, operate the engine at the Fast position. Air is required to thoroughly cut grass clippings, so do not set the height-of-cut so low as to totally surround the mower by uncut grass. Always try to have one side of the mower free from uncut grass, which allows air to be drawn into the mower.

### Using the Smart Speed™ Control System

The Smart Speed™ Control System lever, located below the operating position, gives the operator a choice to drive the machine at two speed ranges, high and low. An operator can benefit from the lower speed setting when maneuvering the machine in tight spaces or operating around delicate landscapes. The low setting can also be used to operate the machine at a high throttle setting and blade speed while still being able to reduce ground speed to increase quality of cut.

### Cutting a Lawn for the First Time

Cut grass slightly longer than normal to ensure that the cutting height of the mower does not scalp any uneven ground. However, the cutting height used in the past is

generally the best one to use. When cutting grass longer than six inches tall, you may want to cut the lawn twice to ensure an acceptable quality of cut.

### Cut 1/3 of the Grass Blade

It is best to cut only about 1/3 of the grass blade. Cutting more than that is not recommended unless grass is sparse, or it is late fall when grass grows more slowly.

### Mowing Direction

Alternate mowing direction to keep the grass standing straight. This also helps disperse clippings which enhances decomposition and fertilization.

### Mow at Correct Intervals

Normally, mow every four days. But remember, grass grows at different rates at different times. So to maintain the same cutting height, which is a good practice, mow more often in early spring. As the grass growth rate slows in mid summer, mow less frequently. If you cannot mow for an extended period, first mow at a high cutting height; then mow again two days later at a lower height setting.

### Avoid Cutting Too Low

If the cutting width of the mower is wider than the mower you previously used, raise the cutting height to ensure that uneven turf is not cut too short.

### Long Grass

If the grass is ever allowed to grow slightly longer than normal, or if it contains a high degree of moisture, raise the cutting height higher than usual and cut the grass at this setting. Then cut the grass again using the lower, normal setting.

### When Stopping

If the machine's forward motion must be stopped while mowing, a clump of grass clippings may drop onto your lawn. To avoid this, move onto a previously cut area with the blades engaged.

### Keep the Underside of the Mower Clean

Clean clippings and dirt from the underside of the mower after each use. If grass and dirt build up inside the mower, cutting quality will eventually become unsatisfactory.

## **Blade Maintenance**

Maintain a sharp blade throughout the cutting season because a sharp blade cuts cleanly without tearing or shredding the grass blades. Tearing and shredding turns grass brown at the edges, which slows growth and increases the chance of disease. Check the cutter blades daily for sharpness, and for any wear or damage. File down any nicks and sharpen the blades as necessary. If a blade is damaged or worn, replace it immediately with a genuine Toro replacement blade.

# Maintenance

**Note:** Determine the left and right sides of the machine from the normal operating position.

## ***Recommended Maintenance Schedule(s)***

Maintenance Service Interval	Maintenance Procedure
After the first 5 hours	<ul style="list-style-type: none"><li>• Change the engine oil.</li></ul>
Before each use or daily	<ul style="list-style-type: none"><li>• Check the safety interlock system.</li><li>• Clean and check the air cleaner foam element.</li><li>• Clean the engine air intake screen.</li><li>• Check the cutting blades.</li><li>• Inspect the grass deflector for damage</li><li>• Clean the mower housing.</li></ul>
Every 25 hours	<ul style="list-style-type: none"><li>• Grease all lubrication points.</li><li>• Check tire pressure.</li><li>• Check the belts for wear/cracks.</li></ul>
Every 50 hours	<ul style="list-style-type: none"><li>• Replace the air cleaner paper element.</li><li>• Check the spark plug.</li></ul>
Every 100 hours	<ul style="list-style-type: none"><li>• Change the engine oil.</li><li>• Change the oil filter.</li><li>• Replace the spark plug.</li><li>• Replace the in-line fuel filter</li><li>• Clean the engine cooling fins and shrouds.</li></ul>
Before storage	<ul style="list-style-type: none"><li>• Charge the battery and disconnect battery cables.</li><li>• Perform all maintenance procedures listed above before storage.</li><li>• Paint any chipped surfaces.</li></ul>

**Important:** Refer to your engine operator's manual for additional maintenance procedures.

### **⚠ CAUTION**

If you leave the key in the ignition switch, someone could accidentally start the engine and seriously injure you or other bystanders.

Remove the key from the ignition and disconnect the wire from the spark plug before you do any maintenance. Set the wire aside so that it does not accidentally contact the spark plug.

## ***Premaintenance Procedures***

- Fuel filter
- Battery and battery cables

## **Raising the Seat**

Make sure the motion control levers are locked in the park position. Lift the seat forward.

The following components can be accessed by raising the seat:

- Serial plate
- Service decal
- Seat adjustment bolts

# Lubrication

## Greasing the Bearings

**Service Interval:** Every 25 hours—Grease all lubrication points.

**Grease Type:** No. 2 General Purpose Lithium Base Grease

1. Park the machine on a level surface and disengage the blade control switch.
2. Move the motion control levers outward to the park position, stop the engine, remove the key, and wait for all moving parts to stop before leaving the operating position.
3. Clean the grease fittings (Figure 24 and Figure 25) with a rag. Make sure to scrape any paint off of the front of the fitting(s).

4. Connect a grease gun to each fitting (Figure 24 and Figure 25). Pump grease into the fittings until grease begins to ooze out of the bearings.
5. Wipe up any excess grease.

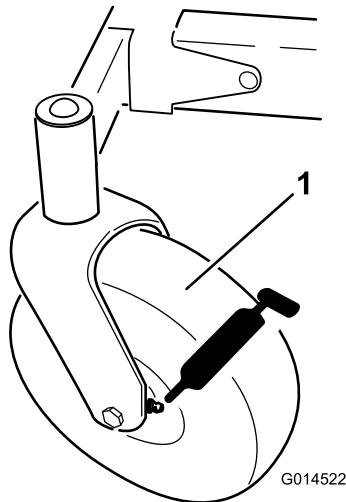

**Figure 24**

1. Front caster tire

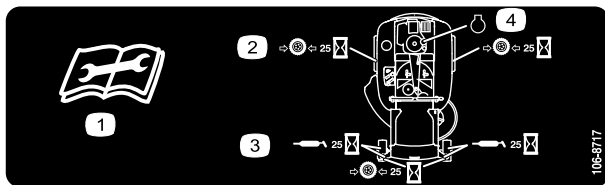

**Figure 25**

Located on the seat pan underside

1. Read the instructions before servicing or performing maintenance.
2. Check tire pressure every 25 operating hours.
3. Grease every 25 operating hours.
4. Engine



# Engine Maintenance

## Servicing the Air Cleaner

**Service Interval:** Before each use or daily—Clean and check the air cleaner foam element.

Every 50 hours—Replace the air cleaner paper element.

**Note:** Service the air cleaner more frequently if the operating conditions are extremely dusty or sandy.

## Removing the Foam and Paper Elements

1. Disengage the blade control (PTO).
2. Stop the engine, wait for all moving parts to stop, and remove the key before leaving the operating position.
3. Clean around the air cleaner to prevent dirt from getting into the engine and causing damage.
4. Remove the air cleaner cover by unscrewing the 2 knobs (Figure 26).

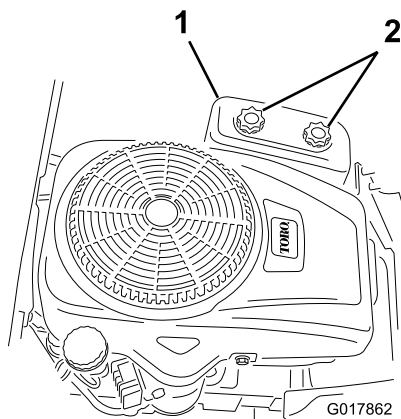

**Figure 26**

1. Air cleaner cover
2. Knobs

5. Carefully remove the foam and paper filter elements from the air cleaner housing (Figure 27).

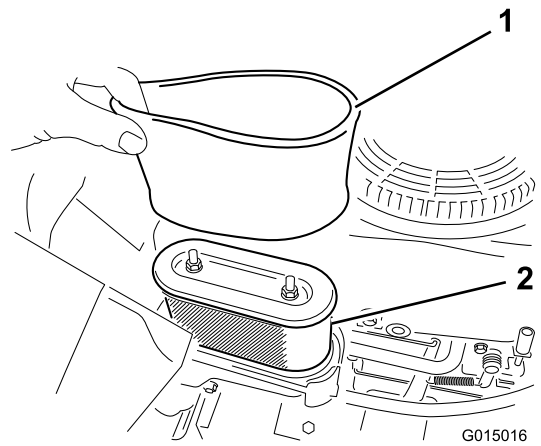

**Figure 27**

1. Foam element
2. Paper element

6. Separate the foam and paper elements.

## Cleaning the Foam and Paper Elements

Foam Element:

1. Wash the foam element in liquid soap and warm water. When the element is clean, rinse it thoroughly.
2. Dry the element by squeezing it in a clean cloth. **Do not oil the element.**

**Important:** Replace the foam element if it is torn or worn.

3. Install the foam element on a clean paper element.

Paper Element:

1. Tap the paper element on a solid flat surface and blow it out from the inside with compressed air to remove dust and dirt.
2. Inspect the element for tears, an oily film, and damage to the rubber seal.

**Important:** Do not clean the paper element with pressurized air or liquids, such as solvents, gasoline, or kerosene. Replace the paper element if it is damaged or cannot be cleaned thoroughly.

3. Clean the inside of the air cleaner cover of all dirt, dust, and debris.

## Installing the Foam and Paper Elements

**Important:** To prevent engine damage, always operate the engine with the complete foam and paper air cleaner assembly installed.

1. Install the foam filter onto the paper filter (Figure 27).

2. Install the foam and paper filter onto the air cleaner housing.
3. Install the air cleaner cover and tighten the two knobs (Figure 26).

## Servicing the Engine Oil

Oil Type: Detergent oil (API service SF, SG, SH, SJ, or higher)

Crankcase Capacity: 34 ounces (1.0 l) when you do not change the filter; 36 ounces (1.05 l) when you change the filter.

Viscosity: See the table below.

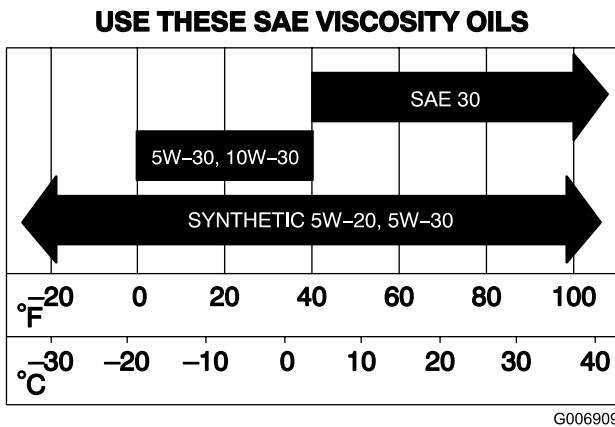

Figure 28

### Checking the Oil Level

1. Park the machine on a level surface.
2. Disengage the blade control (PTO).
3. Stop the engine, wait for all moving parts to stop, and remove the key before leaving the operating position.
4. Clean around the oil dipstick (Figure 29) so that dirt cannot fall into the fill hole and damage the engine.

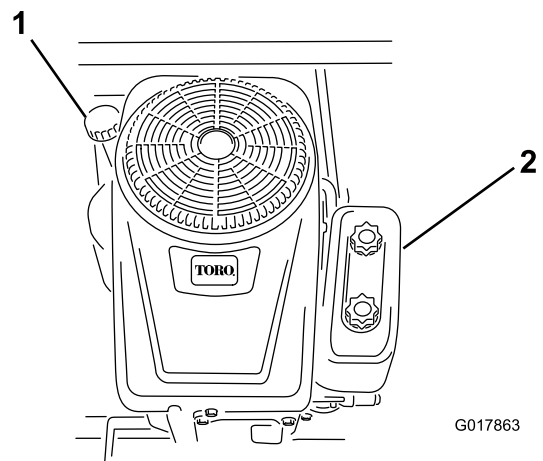

Figure 29

1. Oil dipstick/fill hole
2. Air cleaner

5. Unscrew the oil dipstick and wipe the end clean.
6. Screw the oil dipstick fully onto the fill hole.
7. Unscrew the dipstick again and look at the end. If the oil level is low, slowly pour only enough oil into the fill hole to raise the level to the Full mark on the dipstick.

**Important:** Do not overfill the crankcase with oil and run the engine; engine damage may result.

### Changing the Oil

**Service Interval:** After the first 5 hours

Every 100 hours

1. Park the machine so that the right side is slightly lower than the left side to ensure that the oil drains completely.
2. Disengage the blade control (PTO).
3. Stop the engine, wait for all moving parts to stop, and remove the key before leaving the operating position.
4. Clean the area around the drain valve and on the machine frame. Locate the oil drain hose and slide it over the drain valve (Figure 30).
5. Place the opposite end of the oil drain hose over the machine frame.
6. Place a pan underneath the machine directly below the drain hose as shown in (Figure 30).

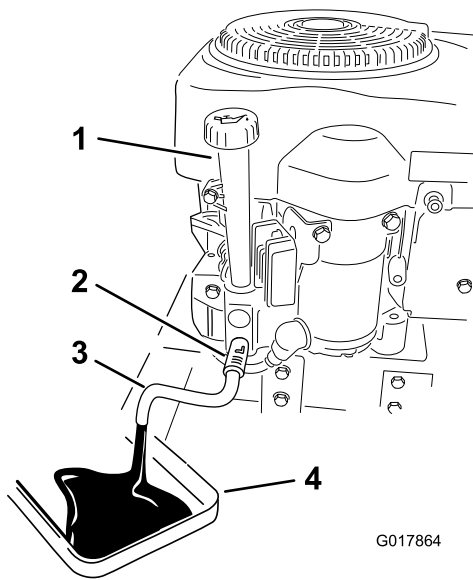

**Figure 30**

- |                  |                   |
|------------------|-------------------|
| 1. Oil fill hole | 3. Oil drain hose |
| 2. Drain valve   | 4. Pan            |

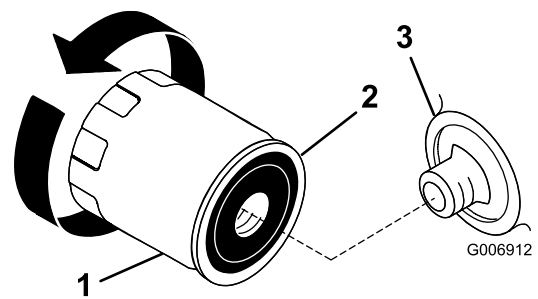

**Figure 31**

- |               |                   |
|---------------|-------------------|
| 1. Oil filter | 3. Filter adapter |
| 2. Gasket     |                   |

7. Turn the drain valve 1/4 counter clockwise to open and allow the oil to drain. Remove the oil fill cap/dipstick (Figure 30).
8. When oil has drained completely, close the oil drain valve. Remove the oil drain hose and wipe up any excess oil on the frame.
 

**Note:** Dispose of the used oil at a certified recycling center.
9. Change the oil filter; refer to Changing the Oil Filter.
10. Slowly pour approximately 80% of the specified amount of oil into the fill hole (Figure 30). Check the oil level; refer to Checking the Oil Level.
11. Install the oil fill cap/dipstick.

## Changing the Oil Filter

**Service Interval:** Every 100 hours

**Note:** Change the oil filter more frequently when the operating conditions are extremely dusty or sandy.

1. Drain the oil from the engine; refer to Changing the Oil.
2. Remove the old oil filter and wipe the filter adapter (Figure 31) gasket surface.

3. Apply a thin coat of new oil to the rubber gasket on the new oil filter (Figure 31).
4. Install the new oil filter to the filter adapter.
5. Turn the oil filter clockwise until the rubber gasket contacts the filter adapter, then tighten the oil filter an additional 1/2 to 3/4 turn (Figure 31).
6. Slowly pour about 80% of the specified amount of oil into the fill hole (Figure 29). Check the oil level; refer to the Checking the Oil Level procedure.

## Servicing the Spark Plug

**Service Interval:** Every 50 hours—Check the spark plug.

Every 100 hours—Replace the spark plug.

Ensure that the air gap between the center and side electrodes is correct before installing the spark plug. Use a spark plug wrench for removing and installing the spark plug and a gapping tool or feeler gauge to check and adjust the air gap. Install a new spark plug if necessary.

**Type:** Champion RC12YC, Autolite 3924, NGK BCPR6ES or equivalent

**Air Gap:** 0.030 inch (0.76 mm)

## Removing the Spark Plug

1. Disengage the blade control (PTO).
2. Stop the engine, wait for all moving parts to stop, and remove the key before leaving the operating position.
3. Disconnect the wire from the spark plug (Figure 32).

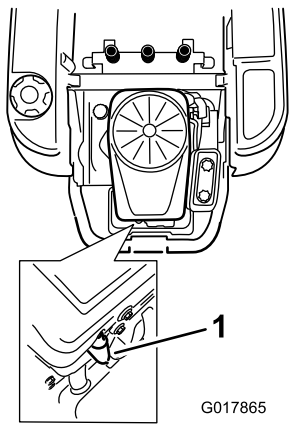

**Figure 32**

1. Spark-plug wire

**Note:** Ensure that the air gap is set correctly.

2. Tighten the spark plug to 15 ft-lb (20 N-m).
3. Connect the wire to the spark plug.

- 
4. Clean around the spark plug to prevent dirt from falling into the engine and potentially causing damage.
  5. Remove the spark plug and metal washer.

## Checking the Spark Plug

1. Inspect the spark plug (Figure 33).

**Note:** If you see light brown or gray on the insulator, the engine is operating properly. A black coating on the insulator usually means that the air cleaner is dirty.

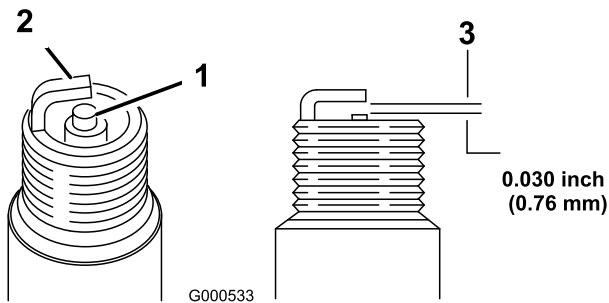

**Figure 33**

1. Center electrode insulator
2. Side electrode
3. Air gap (not to scale)

**Important:** Do not clean the spark plug. Always replace the spark plug when it has a black coating, worn electrodes, an oily film, or cracks.

2. Check the gap between the center and side electrodes (Figure 33). Bend the side electrode if the gap is not correct.

## Installing the Spark Plug

1. Install the spark plug and metal washer.

# Fuel System Maintenance

## **⚠ DANGER**

In certain conditions, gasoline is extremely flammable and highly explosive. A fire or explosion from gasoline can burn you and others and can damage property.

- Perform any fuel related maintenance when the engine is cold. Do this outdoors in an open area. Wipe up any gasoline that spills.
- Never smoke when draining gasoline, and stay away from an open flame or where a spark may ignite the gasoline fumes.

## Replacing the In-line Fuel Filter

**Service Interval:** Every 100 hours—Replace the in-line fuel filter

Never install a dirty filter if it is removed from the fuel line.

1. Park the machine on a level surface and disengage the blade control switch.
2. Move the motion control levers outward to the park position, stop the engine, remove the key, and wait for all moving parts to stop before leaving the operating position.
3. Raise the seat and locate the fuel filters as shown in Figure 34.

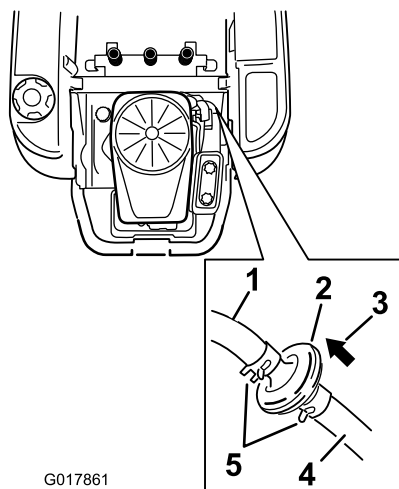

G017861

**Figure 34**

- |                        |                         |
|------------------------|-------------------------|
| 1. Fuel line to engine | 4. Flow direction arrow |
| 2. In-line Fuel filter | 5. Hose clamp           |
| 3. Fuel line from tank |                         |

4. Squeeze the ends of the hose clamps together and slide them away from the filter (Figure 34).
5. Remove the filter from the fuel lines.
6. Install a new filter with the flow direction arrow coming from the fuel tank and pointing to the engine. Move the hose clamps close to the filter (Figure 34) to secure it in place.

# Electrical System Maintenance

## WARNING

### CALIFORNIA Proposition 65 Warning

Battery posts, terminals, and related accessories contain lead and lead compounds, chemicals known to the State of California to cause cancer and reproductive harm.  
Wash hands after handling.

## Charging the Battery

### Removing the Battery

#### WARNING

Battery terminals or metal tools could short against metal machine components causing sparks. Sparks can cause the battery gasses to explode, resulting in personal injury.

- When removing or installing the battery, do not allow the battery terminals to touch any metal parts of the machine.
- Do not allow metal tools to short between the battery terminals and metal parts of the machine.

1. Park the machine on a level surface and disengage the blade control switch.
2. Move the motion control levers outward to the park position, stop the engine, remove the key, and wait for all moving parts to stop before leaving the operating position.
3. Raise the seat to access the battery.
4. Disconnect the negative (black) ground cable from the battery post (Figure 35). Retain all fasteners.

#### WARNING

Incorrect battery cable routing could damage the machine and cables causing sparks. Sparks can cause the battery gasses to explode, resulting in personal injury.

- Always disconnect the negative (black) battery cable before disconnecting the positive (red) cable.
  - Always connect the positive (red) battery cable before connecting the negative (black) cable.
5. Slide the rubber cover up the positive (red) cable. Disconnect the positive (red) cable from the battery post (Figure 35). Retain all fasteners.
  6. Remove the battery hold-down (Figure 35) and lift the battery from the battery tray.

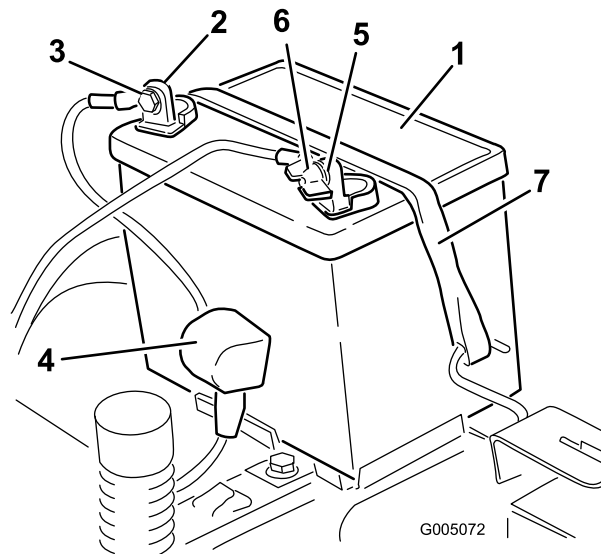

Figure 35

- |                          |                               |
|--------------------------|-------------------------------|
| 1. Battery               | 5. Negative battery post      |
| 2. Positive battery post | 6. Wing nut, washer, and bolt |
| 3. Bolt, washer, and nut | 7. Battery hold-down          |
| 4. Terminal boot         |                               |

## Charging the Battery

**Service Interval:** Before storage—Charge the battery and disconnect battery cables.

1. Remove the battery from the chassis; refer to Removing the Battery.
2. Charge the battery for a minimum of 1 hour at 6 to 10 amps. Do not overcharge the battery.
3. When the battery is fully charged, unplug the charger from the electrical outlet, then disconnect the charger leads from the battery posts (Figure 36).

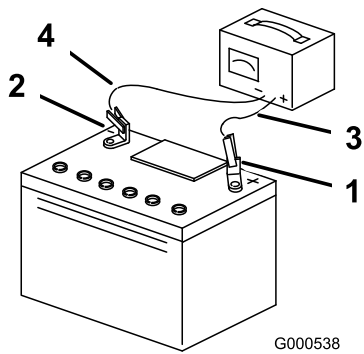

**Figure 36**

- |                          |                           |
|--------------------------|---------------------------|
| 1. Positive battery post | 3. Red (+) charger lead   |
| 2. Negative battery post | 4. Black (-) charger lead |

**Note:** Do not run the machine with the battery disconnected, electrical damage may occur.

## Installing the Battery

1. Position the battery in the tray (Figure 35).
2. Install the positive (red) battery cable to the positive (+) battery terminal using the fasteners removed previously.
3. Install the negative battery cable to the negative (-) battery terminal using the fasteners removed previously.
4. Slide the red terminal boot onto the positive (red) battery post.
5. Secure the battery with the hold-down (Figure 35).
6. Lower the seat.

## Servicing the Fuses

The electrical system is protected by fuses. It requires no maintenance; however, if a fuse blows, check the component/circuit for a malfunction or short.

Fuse:

- Main F1-30 amp, blade-type
  - Charge Circuit F2-25 amp, blade-type
1. Remove the screws securing the control panel to the machine. Retain all fasteners
  2. Lift the control pane up to access the main wiring harness and fuse block (Figure 37).
  3. To replace a fuse, pull out on the fuse to remove it (Figure 37).

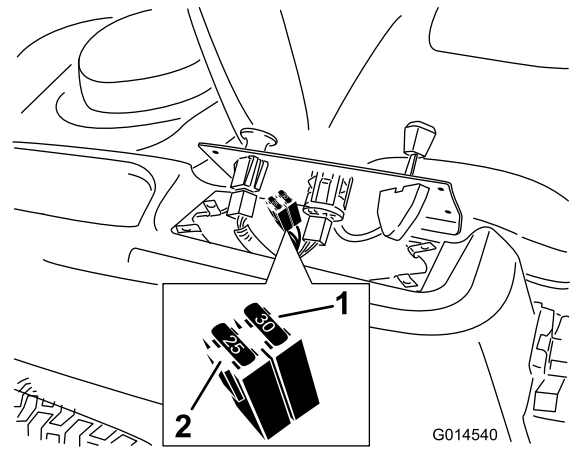

**Figure 37**

- |                |                          |
|----------------|--------------------------|
| 1. Main-30 amp | 2. Charge circuit-25 amp |
|----------------|--------------------------|

4. Return the control panel to its original position. Use the screws removed previously to secure the panel to the machine.

# Drive System Maintenance

1. Locate the shaft on the electric brake where the brake link arms are connected.
2. Rotate the shaft forward to release the brake.

## Checking the Tire Pressure

**Service Interval:** Every 25 hours—Check tire pressure.

Maintain the air pressure in the front and rear tires as specified. Uneven tire pressure can cause uneven cut. Check the pressure at the valve stem (Figure 38). Check the tires when they are cold to get the most accurate pressure reading.

Refer to the maximum pressure suggested by the tire manufacturer on the sidewall of the caster wheel tires.

Inflate the rear drive wheel tires to 12 psi.

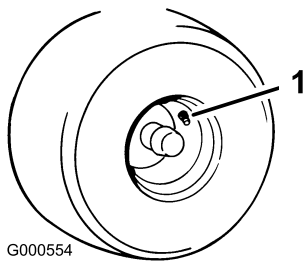

**Figure 38**

1. Valve stem

---

## Releasing the Electric Brake

The electric brake can be released by manually rotating the link arms forward. Once the electric brake is energized the brake will reset.

To release the brake:

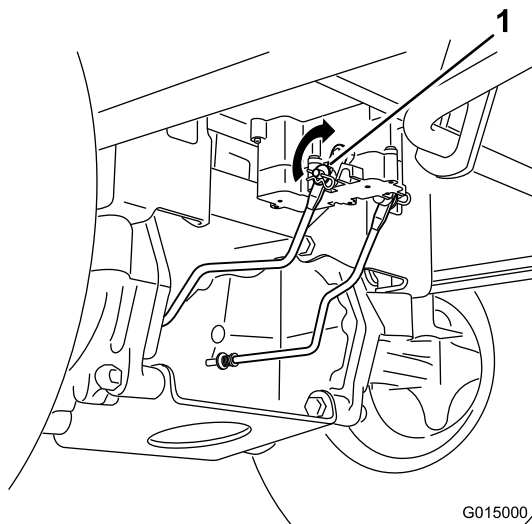

**Figure 39**

1. Brake link arm on the electric brake control module



# Cooling System Maintenance

## Cleaning the Engine Screen

**Service Interval:** Before each use or daily—Clean the engine air intake screen.

To ensure proper cooling, make sure the grass screen, cooling fins, and other external surfaces of the engine are kept clean at all times.

Use a dry brush to clean grass and accumulated debris from the air intake screen and around the engine.

**Important:** To prevent contaminating the fuel system, do not use water to clean the engine.

## Cleaning the Engine Cooling Fins and Shrouds

**Service Interval:** Every 100 hours—Clean the engine cooling fins and shrouds.

1. Disengage the blade control switch and move the control levers to the neutral locked position and apply the parking brake.
2. Stop the engine, remove the key, and wait for all moving parts to stop before leaving the operating position.
3. Remove the air intake screen and cooling shrouds.
4. Clean the debris and grass from the engine parts.
5. Install the air intake screen and cooling shrouds.

# Mower Maintenance

## Servicing the Cutting Blades

Maintain sharp blades throughout the cutting season because sharp blades cut cleanly without tearing or shredding the grass blades. Tearing and shredding turns grass brown at the edges, which slows growth and increases the chance of disease.

Check the cutter blades daily for sharpness, and for any wear or damage. File down any nicks and sharpen the blades as necessary. If a blade is damaged or worn, replace it immediately with a genuine Toro replacement blade. For convenient sharpening and replacement, you may want to keep extra blades on hand.

### **▲ WARNING**

A worn or damaged blade can break, and a piece of the blade could be thrown into the operator's or bystander's area, resulting in serious personal injury or death.

- Inspect the blade periodically for wear or damage.
- Replace a worn or damaged blade.

## Before Inspecting or Servicing the Blades

Park the machine on a level surface, disengage the blade control switch, and move the motion control levers outward to the park position. Stop the engine and remove the key.

## Inspecting the Blades

**Service Interval:** Before each use or daily—Check the cutting blades.

1. Inspect the cutting edges (Figure 40). If the edges are not sharp or have nicks, remove and sharpen the blades; refer to Sharpening the Blades.
2. Inspect the blades, especially the curved area (Figure 40). If you notice any damage, wear, or a slot forming in this area (item 3 in Figure 40), immediately install a new blade.

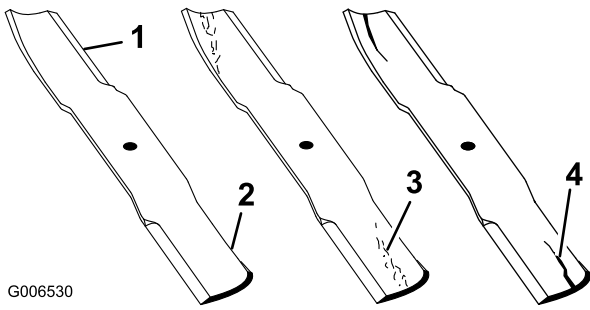

**Figure 40**

- |                 |                      |
|-----------------|----------------------|
| 1. Cutting edge | 3. Wear/slot forming |
| 2. Curved area  | 4. Damage            |

3. Measure from the tip of the blade to the flat surface here.

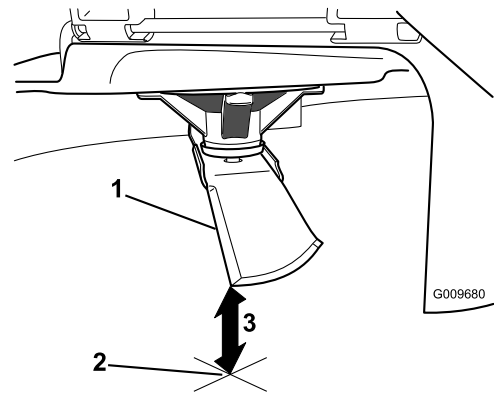

**Figure 42**

1. Blade, in position for measuring
2. Level surface
3. Measured distance between blade and surface (A)

## Checking for Bent Blades

**Note:** The machine must be on a level surface for the following procedure.

1. Raise the mower deck to the highest height-of-cut position; also considered the 'transport' position.
2. While wearing thickly padded gloves or other adequate hand protection slowly rotate blade to be measured into a position that allows effective measurement of the distance between the cutting edge and the level surface the machine is on.

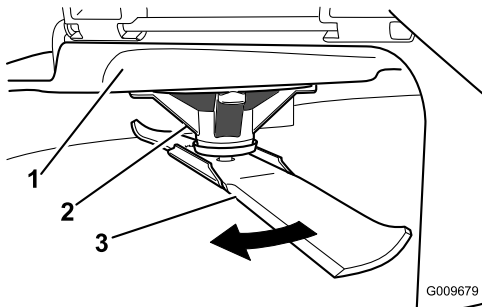

**Figure 41**

- |                    |          |
|--------------------|----------|
| 1. Deck            | 3. Blade |
| 2. Spindle housing |          |

4. Rotate the same blade 180 degrees so that the opposing cutting edge is now in the same position.

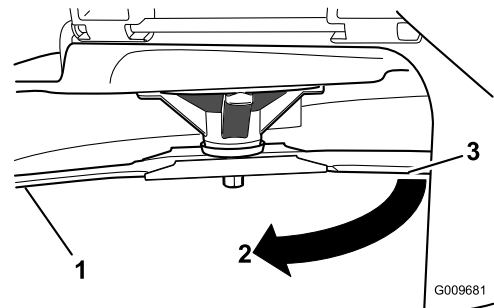

**Figure 43**

1. Blade, side previously measured
2. Measurement position used previously
3. Opposing side of blade being moved into measurement position

5. Measure from the tip of the blade to the flat surface here. The variance should be no more than 1/8 inch (3mm).

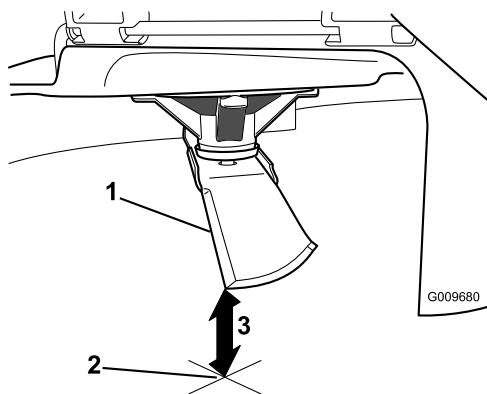

Figure 44

1. Opposing blade edge, in position for measuring
2. Level surface
3. Second measured distance between blade and surface (B)

### ⚠ WARNING

A blade that is bent or damaged could break apart and could seriously injure or kill you or bystanders.

- Always replace bent or damaged blade with a new blade.
- Never file or create sharp notches in the edges or surfaces of blade.

- A. If the difference between A and B is greater than 1/8 inch (3mm) replace the blade with a new blade. Refer to Removing the Blades and Installing the Blades.

**Note:** If a bent blade is replaced with a new one and the dimension obtained continues to exceed 1/8 inch (3mm), the blade spindle could be bent. Contact an Authorized Toro Dealer for service.

- B. If the variance is within constraints, move to the next blade..

Repeat this procedure on each blade.

## Removing the Blades

The blades must be replaced if a solid object is hit, if the blade is out of balance, or the blade is bent. To ensure optimum performance and continued safety conformance of the machine, use genuine Toro replacement blades. Replacement blades made by other manufacturers may result in non-conformance with safety standards.

Hold the blade end using a rag or thickly-padded glove. Remove the blade bolt, curved washer, blade stiffener, and blade from the spindle shaft (Figure 45).

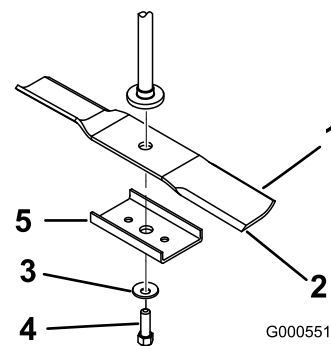

Figure 45

1. Sail area of blade
2. Blade
3. Curved washer
4. Blade bolt
5. Blade stiffener

## Sharpening the Blades

1. Use a file to sharpen the cutting edge at both ends of the blade (Figure 46). Maintain the original angle. The blade retains its balance if the same amount of material is removed from both cutting edges.

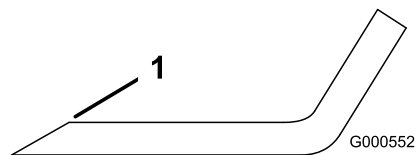

Figure 46

1. Sharpen at original angle

2. Check the balance of the blade by putting it on a blade balancer (Figure 47). If the blade stays in a horizontal position, the blade is balanced and can be used. If the blade is not balanced, file some metal off the end of the sail area only (Figure 46). Repeat this procedure until the blade is balanced.

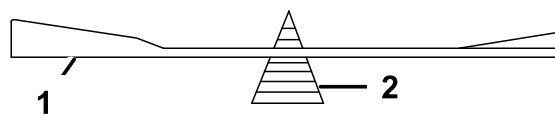

Figure 47

1. Blade
2. Balancer

## Installing the Blades

1. Install the blade onto the spindle shaft (Figure 45).

**Important:** The curved part of the blade must be pointing upward toward the inside of the mower to ensure proper cutting.

2. Install the blade stiffener, the curved washer (cupped side toward the blade) and the blade bolt (Figure 45).
3. Torque the blade bolt to 35-65 ft-lb (47-88 N-m).

# Leveling the Mower Deck

Check to ensure the mower deck is level any time you install the mower or when you see an uneven cut on your lawn.

The mower deck must be checked for bent blades prior to leveling; any bent blades must be removed and replaced. Refer to the Checking for Bent Blades procedure before continuing.

The mower deck must be leveled side-to-side first then the front to rear slope can be adjusted.

Requirements:

- The machine must be on a level surface.
- All four tires must be properly inflated. Refer to Checking the Tire Pressure in the Drive System Maintenance section.

## Side-to-Side Leveling

1. Park the machine on a level surface and disengage the blade control switch.
2. Move the motion control levers outward to the park position, stop the engine, remove the key, and wait for all moving parts to stop before leaving the operating position.
3. Set the height-of-cut lever to middle position.
4. Carefully rotate the blade(s) so that they are all side to side (Figure 48).

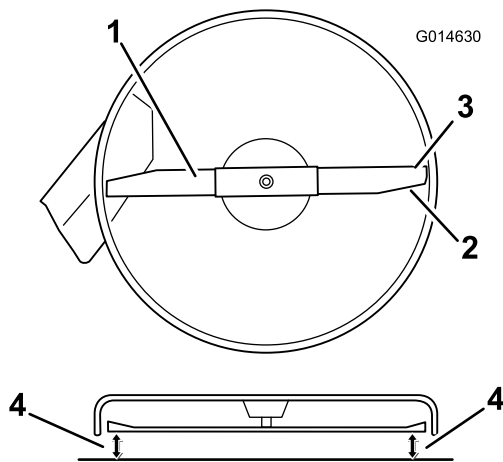

Figure 48

- |                       |   |
|-----------------------|---|
| 1. Blade side to side | 3. Outside cutting edges                                      |
| 2. Sail area of blade | 4. Measure from the tip of the blade to the flat surface here |

5. Measure between the outside cutting edges and the flat surface (Figure 48). If both measurements are not within 3/16 inch (5 mm), an adjustment is required; continue with this procedure.

6. Support the weight of mower deck by placing wood blocks under the edges of the deck.

**Note:** Avoid placing the supports under any anti-scalp rollers if present on the deck.

7. Move to the left side of the machine. Remove the side carriage bolt and locking nut from the fixed position and install it into the rear, slotted position (Figure 49). Leave the lock nut slightly loose.

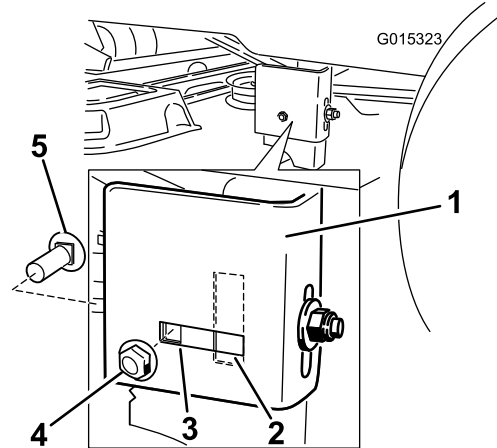

Figure 49

- |                                |                       |
|--------------------------------|-----------------------|
| 1. Hanger bracket              | 4. Side locking nut.  |
| 2. Slotted adjustment position | 5. Side carriage bolt |
| 3. Fixed position              |                       |

8. Loosen the rear locking nut on the hanger bracket just enough to allow the hanger to be adjusted (Figure 49).

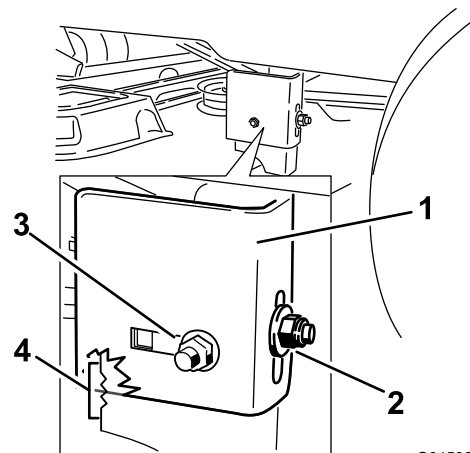
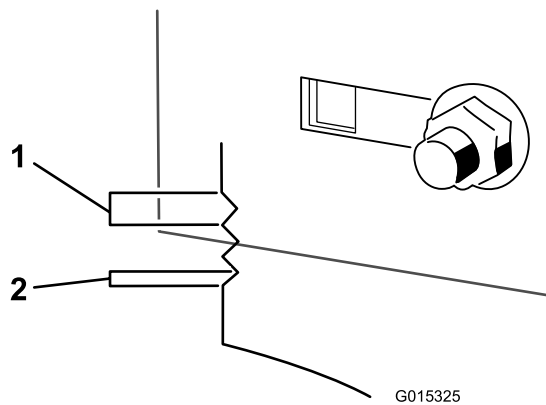

Figure 50

- |                     |  |
|---------------------|--|
| 1. Hanger bracket   | 3. Side locking nut, slotted position. |
| 2. Rear locking nut | 4. Adjustment notches                  |

9. Use the notches on the welded bracket to measure the amount of adjustment. Each notch surface is equivalent to 0.25 inch, while a single side is 0.125

inch (Figure 51). Adjust the height of the mower deck to the desired height.



**Figure 51**

1. 0.25 inch
2. 0.125 inch

10. Stop the deck at the adjusted position and tighten the rear locking nut on the hanger bracket to hold the new position (Figure 50). Tighten the side locking nut on the hanger bracket.
11. Continue leveling the deck by checking the front-to-rear blade slope; refer to Adjusting the Front-to-Rear Blade Slope.

## Adjusting the Front-to-Rear Blade Slope

Check the front-to-rear blade slope any time you install the mower. If the front of the mower is more than 5/16 inch (7.9 mm) lower than the rear of the mower, adjust the blade level using the following instructions:

1. Park the machine on a level surface and disengage the blade control switch.
2. Move the motion control levers outward to the park position, stop the engine, remove the key, and wait for all moving parts to stop before leaving the operating position.
3. Set the height-of-cut lever to middle position.

**Note:** Check and adjust the side-to-side blade level if you have not checked the setting; refer to Side-to-Side Leveling.

4. Carefully rotate the blades so they are facing front to rear (Figure 52).

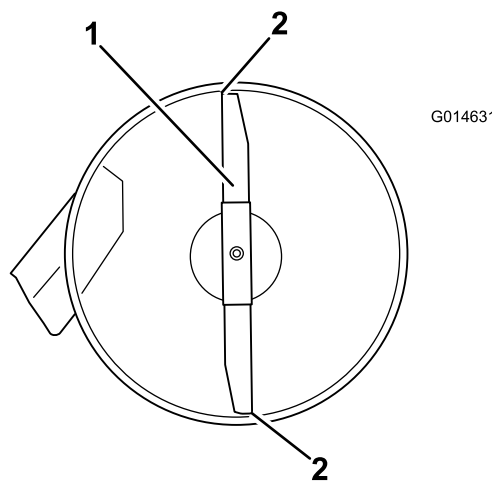

**Figure 52**

1. Blade front to rear
  2. Measure from the tip of the blade to the flat surface here
5. Measure from the tip of the front blade to the flat surface and the tip of the rear blade to the flat surface (Figure 52). If the front blade tip is not 1/16-5/16 inch (1.6-7.9 mm) lower than the rear blade tip, adjust the front locknut.
  6. To adjust the front-to-rear blade slope, rotate the adjustment nut in the front of the mower (Figure 53).

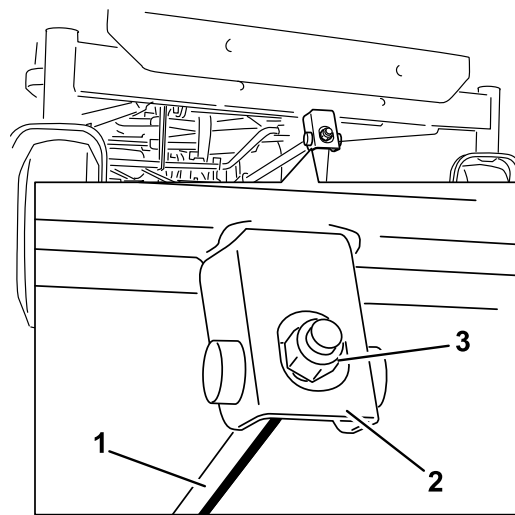

**Figure 53**

1. Adjusting rod
  2. Adjusting block
  3. Lock nut
7. To raise the front of the mower, tighten the adjustment nut. To lower the front of the mower, loosen the adjustment nut.
  8. After adjustment, check the front-to-rear slope again. Continue adjusting the nut until the front blade tip

is 1/16-5/16 inch (1.6-7.9 mm) lower than the rear blade tip (Figure 52).

9. When the front-to-rear blade slope is correct check the side-to-side level of the mower again; refer to Leveling the Mower from Side-to-Side.

## Removing the Mower

1. Park the machine on a level surface and disengage the blade control switch.
2. Move the motion control levers outward to the park position, stop the engine, remove the key, and wait for all moving parts to stop before leaving the operating position.
3. Lower the height-of-cut lever to the lowest position.
4. Remove the hairpin cotter from the front support rod and remove the rod from the deck bracket (Figure 54). Carefully lower the front of the mower deck to the ground.

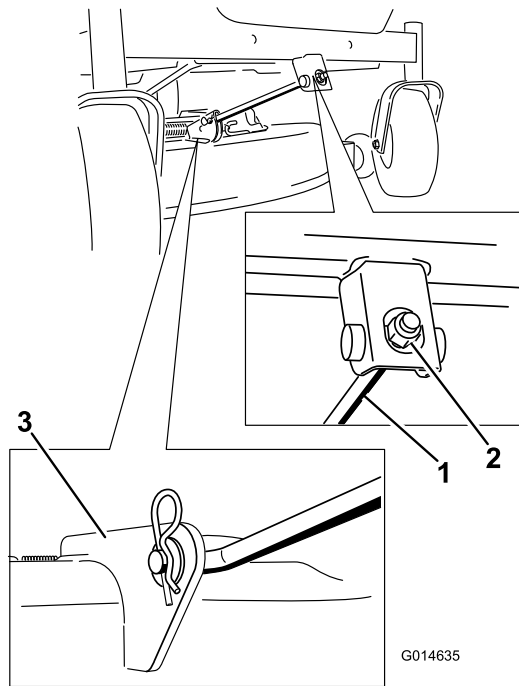

Figure 54

1. Front support rod
2. Locking nut
3. Deck bracket

5. Lift the mower deck and hanger brackets clear of the rear lift rod and lower the mower carefully to the ground (Figure 55).

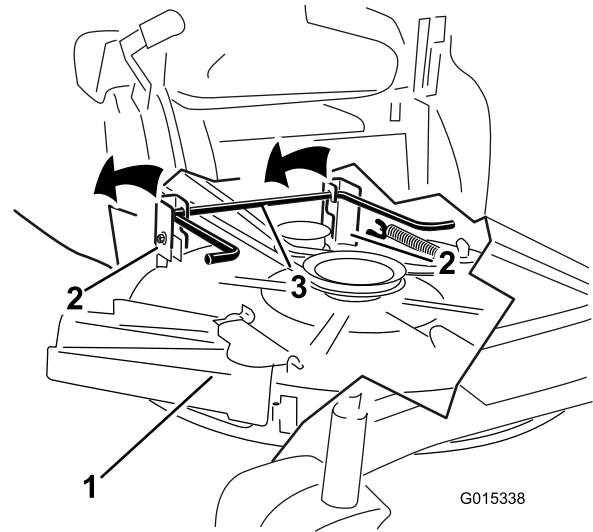

Figure 55

1. Mower deck
2. Hanger bracket
3. Rear lift rod

6. Slide the mower deck rearward to remove the mower belt from the engine pulley.
7. Slide the mower deck out from underneath the machine.

**Note:** Retain all parts for future installation.

## Mower Belt Maintenance

### Inspecting the Belts

**Service Interval:** Every 25 hours—Check the belts for wear/cracks.

Check the belts for cracks, frayed edges, burn marks, or any other damage. Replace damaged belts.

### Replacing the Mower Belt

Squealing when the belt is rotating, blades slipping when cutting grass, frayed belt edges, burn marks, and cracks are signs of a worn mower belt. Replace the mower belt if any of these conditions are evident.

1. Park the machine on a level surface and disengage the blade control switch.
2. Move the motion control levers outward to the park position, stop the engine, remove the key, and wait for all moving parts to stop before leaving the operating position.
3. Set the height-of-cut at the lowest cutting position [1-1/2 inch (38 mm)].
4. Using a spring removal tool, (Toro part no. 92-5771), remove the idler spring from the deck hook to

remove tension on the idler pulley and roll the belt off of the pulleys (Figure 56).

## ⚠ WARNING

The spring is under tension when installed and can cause personal injury.

Be careful when removing the belt.

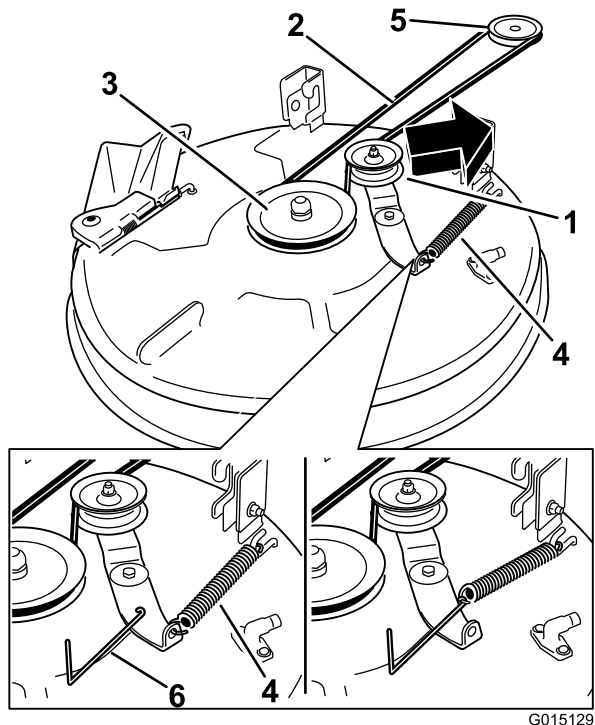

Figure 56

- |                   |                        |
|-------------------|------------------------|
| 1. Idler pulley   | 4. Spring              |
| 2. Mower belt     | 5. Engine pulley       |
| 3. Outside pulley | 6. Spring removal tool |

- Route the new belt around the engine pulley and mower pulleys (Figure 56).
- Using a spring removal tool, (Toro part no. 92-5771), install the idler spring over the deck hook and placing tension on the idler pulley and mower belt (Figure 56).

## Installing the Mower

- Park the machine on a level surface and disengage the blade control switch.
- Move the motion control levers outward to the park position, stop the engine, remove the key, and wait for all moving parts to stop before leaving the operating position.
- Slide the mower under the machine.
- Lower the height-of-cut lever to the lowest position.

- Lift the rear of the mower deck and guide the hanger brackets over the rear lift rod (Figure 55).
- Attach the front support rod to the mower deck with the clevis pin and hairpin cotter (Figure 54).
- Install the mower belt onto the engine pulley; refer to Replacing the Mower Belt.

## Replacing the Grass Deflector

**Service Interval:** Before each use or daily—Inspect the grass deflector for damage

## ⚠ WARNING

An uncovered discharge opening could allow the lawn mower to throw objects in the operator's or bystander's direction and result in serious injury. Also, contact with the blade could occur.

Never operate the machine without grass deflector, discharge cover or grass collection system in place.

- Locate items shown in Figure 57.

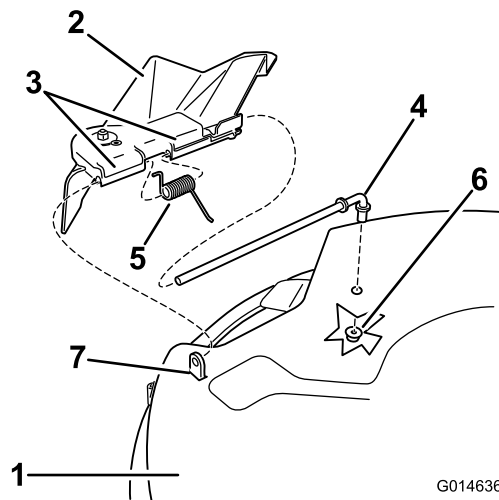

Figure 57

- |                            |                    |
|----------------------------|--------------------|
| 1. Mower deck              | 5. Spring          |
| 2. Grass deflector         | 6. Nut (3/8 inch)  |
| 3. Grass deflector bracket | 7. Short stand-off |
| 4. Rod                     |                    |

- Remove the nut (3/8 inch) from the rod under the mower (Figure 57).
- Slide the rod out of the short stand-off, spring, and grass deflector (Figure 57). Remove the damaged or worn grass deflector.
- Replace the grass deflector (Figure 57).
- Slide rod, straight end, through the rear grass deflector bracket.

6. Place the spring on the rod, with end wires down, and between the grass deflector brackets. Slide rod through second grass deflector bracket (Figure 57).
7. Insert rod at front of grass deflector into short stand-off on deck. Secure rear end of rod into the mower with a nut (3/8 inch) (Figure 57).

**Important:** The grass deflector must be spring loaded in the down position. Lift the deflector up to test that it snaps to the full down position.

## Cleaning

### Washing the Underside of the Mower

**Service Interval:** Before each use or daily—Clean the mower housing.

Wash the underside of the mower after each use to prevent grass buildup for improved mulch action and clipping dispersal.

1. Park the machine on a level surface and disengage the blade control switch.
2. Move the motion control levers outward to the park position, stop the engine, remove the key, and wait for all moving parts to stop before leaving the operating position.
3. Attach the hose coupling to the end of the mower washout fitting, and turn the water on high (Figure 58).

**Note:** Spread petroleum jelly on the washout fitting O-ring to make the coupling slide on easier and protect the O-ring.

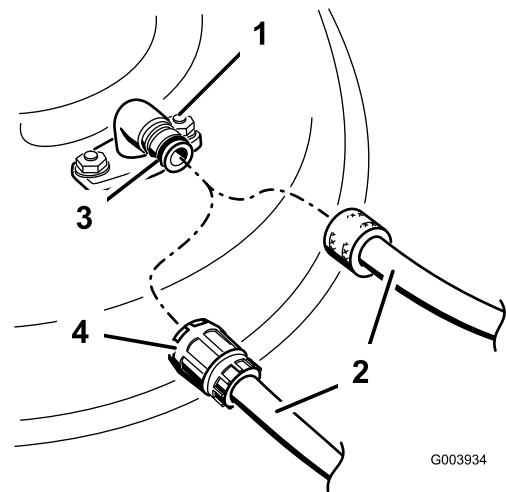

**Figure 58**

- |                    |             |
|--------------------|-------------|
| 1. Washout fitting | 3. O-ring   |
| 2. Hose            | 4. Coupling |

4. Lower the mower to the lowest height-of-cut.
5. Sit on the seat and start the engine. Engage the blade control switch and let the mower run for one to three minutes.
6. Disengage the blade control switch, stop the engine, and remove the ignition key. Wait for all moving parts to stop.
7. Turn the water off and remove the coupling from the washout fitting.



**Note:** If the mower is not clean after one washing, let it soak for 30 minutes. Then repeat the procedure of washing the underside of the mower.

8. Run the mower again for one to three minutes to remove excess water.

### **⚠ WARNING**

**A broken or missing washout fitting could expose you and others to thrown objects or blade contact. Contact with blade or thrown debris can cause injury or death.**

- Replace broken or missing washout fitting immediately, before using mower again.
- Never put your hands or feet under the mower or through openings in the mower.

# Storage

## Cleaning and Storage

1. Disengage the blade control switch, move the motion controls outward to the park position, stop the engine, and remove the key.
2. Remove grass clippings, dirt, and grime from the external parts of the entire machine, especially the engine. Clean dirt and chaff from the outside of the engine cylinder head fins and blower housing.  
**Important:** You can wash the machine with mild detergent and water. Do not pressure wash the machine. Avoid excessive use of water, especially near the control panel, engine, hydraulic pumps, and motors.
3. Service the air cleaner; refer to Servicing the Air Cleaner in the Engine Maintenance section.
4. Grease and oil the machine; refer to the Lubrication section.
5. Change the crankcase oil and filter; refer to Servicing the Engine Oil in the Engine Maintenance section.
6. Check the tire pressure; refer to Checking the Tire Pressure in the Drive System Maintenance section.
7. Charge the battery; refer to Servicing the Battery in the Electrical System Maintenance section.
8. Check the condition of the blades; refer to Servicing the Cutting Blades in the Mower Maintenance section.
9. Prepare the machine for storage when non-use occurs over 30 days. Prepare the machine for storage as follows.
10. Add a petroleum based stabilizer/conditioner to the fuel in the tank. Follow the mixing instructions from the stabilizer manufacturer. Do not use an alcohol based stabilizer (ethanol or methanol).

**Note:** A fuel stabilizer/conditioner is most effective when mixed with fresh gasoline and used at all times.

Run the engine to distribute the conditioned fuel through the fuel system (5 minutes).

Stop the engine, allow it to cool, and drain the fuel tank.

Restart the engine and run it until it stops.

Choke the engine. Start and run the engine until it will not start.

Dispose of fuel properly. Recycle pursuant to local codes.

**Important: Do not store stabilizer/conditioned gasoline over 30 days.**

11. Remove the spark plug(s) and check its condition; refer to Servicing the Spark Plug in the Engine Maintenance section. With the spark plug(s) removed from the engine, pour two tablespoons of engine oil into the spark plug hole. Use the starter to crank the engine and distribute the oil inside the cylinder. Install the spark plug(s). Do not install the wire on the spark plug(s).
12. Clean any dirt and chaff from the top of the mower.
13. Scrape any heavy buildup of grass and dirt from the underside of the mower, then wash the mower with a garden hose.
14. Check the condition of the drive and mower belts.
15. Check and tighten all bolts, nuts, and screws. Repair or replace any part that is worn or damaged.
16. Paint all scratched or bare metal surfaces. Paint is available from your Authorized Service Dealer.
17. Store the machine in a clean, dry garage or storage area. Remove the key from the ignition switch and keep it in a memorable place. Cover the machine to protect it and keep it clean.

# Troubleshooting

Problem	Possible Cause	Corrective Action
The engine overheats.	<ol style="list-style-type: none"> <li>1. The engine load is excessive.</li> <li>2. The oil level in the crankcase is low.</li> <li>3. The cooling fins and air passages under the engine blower housing are plugged.</li> <li>4. The air cleaner is dirty.</li> <li>5. Dirt, water, or stale fuel is in fuel system.</li> </ol>	<ol style="list-style-type: none"> <li>1. Reduce ground speed.</li> <li>2. Add oil to the crankcase.</li> <li>3. Remove the obstruction from the cooling fins and air passages.</li> <li>4. Clean or replace the air cleaner element.</li> <li>5. Contact an Authorized Service Dealer</li> </ol>
The starter does not crank	<ol style="list-style-type: none"> <li>1. The blade control switch is engaged.</li> <li>2. The motion control levers are not in the park position.</li> <li>3. The battery is dead.</li> <li>4. The electrical connections are corroded or loose.</li> <li>5. A fuse is blown.</li> <li>6. A relay or switch is damaged.</li> </ol>	<ol style="list-style-type: none"> <li>1. Move the blade control switch to Disengaged.</li> <li>2. Move the motion control levers outward to the park position.</li> <li>3. Charge the battery.</li> <li>4. Check the electrical connections for good contact.</li> <li>5. Replace the fuse.</li> <li>6. Contact an Authorized Service Dealer.</li> </ol>
The engine will not start, starts hard, or fails to keep running.	<ol style="list-style-type: none"> <li>1. The fuel tank is empty.</li> <li>2. The choke is not on.</li> <li>3. The air cleaner is dirty.</li> <li>4. The spark plug wire(s) is loose or disconnected.</li> <li>5. The spark plug(s) is pitted, fouled, or the gap is incorrect.</li> <li>6. There is dirt in fuel filter.</li> <li>7. Dirt, water, or stale fuel is in fuel system.</li> <li>8. There is incorrect fuel in the fuel tank.</li> <li>9. The oil level in the crankcase is low.</li> </ol>	<ol style="list-style-type: none"> <li>1. Fill the fuel tank.</li> <li>2. Move the choke lever to On.</li> <li>3. Clean or replace the air cleaner element.</li> <li>4. Install the wire(s) on the spark plug.</li> <li>5. Install a new, correctly gapped spark plug(s).</li> <li>6. Replace the fuel filter.</li> <li>7. Contact an Authorized Service Dealer.</li> <li>8. Drain the tank and replace the fuel with the proper type.</li> <li>9. Add oil to the crankcase.</li> </ol>
The engine loses power.	<ol style="list-style-type: none"> <li>1. The engine load is excessive.</li> <li>2. The air cleaner is dirty.</li> <li>3. The oil level in the crankcase is low.</li> <li>4. The cooling fins and air passages under the engine blower housing are plugged.</li> <li>5. The spark plug(s) is pitted, fouled, or the gap is incorrect.</li> <li>6. The fuel tank vent is blocked.</li> <li>7. There is dirt in the fuel filter.</li> <li>8. Dirt, water, or stale fuel is in the fuel system.</li> <li>9. There is incorrect fuel in the fuel tank.</li> </ol>	<ol style="list-style-type: none"> <li>1. Reduce ground speed.</li> <li>2. Clean the air cleaner element.</li> <li>3. Add oil to the crankcase.</li> <li>4. Remove the obstruction from the cooling fins and air passages.</li> <li>5. Install a new, correctly gapped spark plug(s).</li> <li>6. Contact an Authorized Service Dealer.</li> <li>7. Replace the fuel filter.</li> <li>8. Contact an Authorized Service Dealer.</li> <li>9. Drain the tank and replace the fuel with the proper type.</li> </ol>
The machine does not drive.	<ol style="list-style-type: none"> <li>1. The bypass valves are open</li> <li>2. The traction belts are worn, loose, or broken.</li> <li>3. The traction belts are off of the pulleys.</li> <li>4. The transmission has failed.</li> </ol>	<ol style="list-style-type: none"> <li>1. Close the tow valves.</li> <li>2. Contact an Authorized Service Dealer.</li> <li>3. Contact an Authorized Service Dealer.</li> <li>4. Contact an Authorized Service Dealer.</li> </ol>

Problem	Possible Cause	Corrective Action
There is abnormal vibration.	<ol style="list-style-type: none"> <li>1. The engine mounting bolts are loose.</li> <li>2. The engine pulley, idler pulley, or blade pulley is loose.</li> <li>3. The engine pulley is damaged.</li> <li>4. The cutting blade(s) is/are bent or unbalanced.</li> <li>5. A blade mounting bolt is loose.</li> <li>6. A blade spindle is bent.</li> </ol>	<ol style="list-style-type: none"> <li>1. Tighten the engine mounting bolts.</li> <li>2. Tighten the appropriate pulley.</li> <li>3. Contact an Authorized Service Dealer.</li> <li>4. Install a new cutting blade(s).</li> <li>5. Tighten the blade mounting bolt.</li> <li>6. Contact an Authorized Service Dealer.</li> </ol>
Uneven cutting height.	<ol style="list-style-type: none"> <li>1. The blade(s) is not sharp.</li> <li>2. A cutting blade(s) is/are bent.</li> <li>3. The mower is not level.</li> <li>4. An anti-scalp wheel is not set correctly.</li> <li>5. The underside of the mower is dirty.</li> <li>6. The tire pressure is incorrect.</li> <li>7. A blade spindle is bent.</li> </ol>	<ol style="list-style-type: none"> <li>1. Sharpen the blade(s).</li> <li>2. Install a new cutting blade(s).</li> <li>3. Level the mower from side-to-side and front-to-rear.</li> <li>4. Adjust the anti-scalp wheel height.</li> <li>5. Clean the underside of the mower.</li> <li>6. Adjust the tire pressure.</li> <li>7. Contact an Authorized Service Dealer.</li> </ol>
The blades do not rotate.	<ol style="list-style-type: none"> <li>1. The drive belt is worn, loose or broken.</li> <li>2. The drive belt is off of the pulley.</li> <li>3. The Power Take-Off (PTO) switch or PTO clutch is faulty.</li> <li>4. The mower belt is worn, loose, or broken.</li> </ol>	<ol style="list-style-type: none"> <li>1. Install a new drive belt.</li> <li>2. Install the drive belt and check the adjusting shafts and belt guides for the correct position.</li> <li>3. Contact an Authorized Service Dealer.</li> <li>4. Install a new mower belt.</li> </ol>

# Schematics

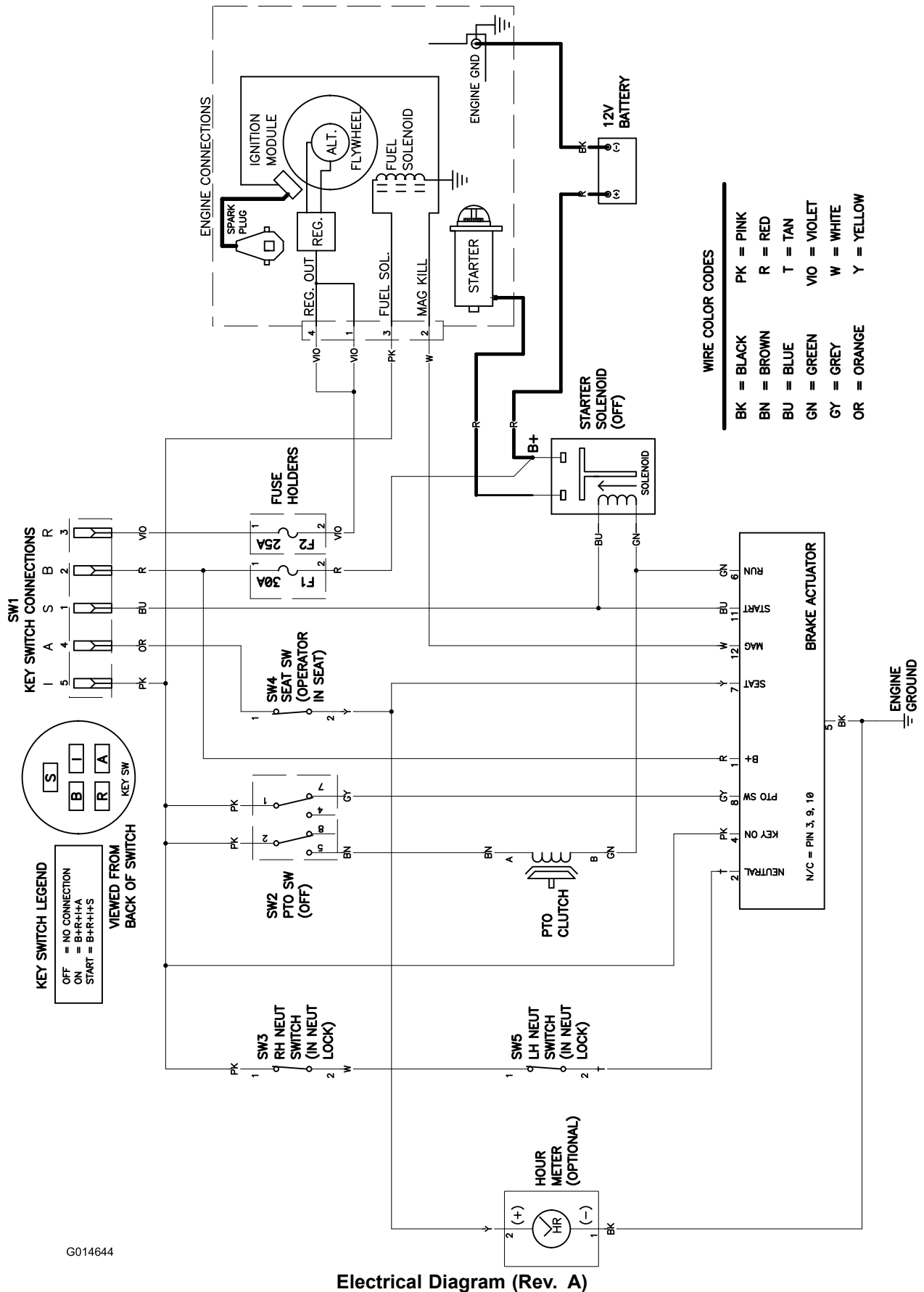

G014644

Electrical Diagram (Rev. A)



## California and Federal Exhaust and Evaporative Emission Control Warranty Statement

A Two-Year Limited Warranty

### Your Warranty Rights and Obligations

The California Air Resources Board (CARB), the U.S. Environmental Protection Agency (EPA), and The Toro Company, are pleased to explain the emission control system warranty on your 2012 small off-road engine. In California and the United States, new small off-road engines must be designed, built and equipped to meet the State's stringent anti-smog standards. The Toro Company warrants the emission control system on your small off-road engine for the period of time listed above, provided there has been no abuse, neglect, or improper maintenance of your small off-road engine.

Your emission control system may include parts such as the carburetor, fuel-injection system, the ignition system, catalytic converter, fuel tanks, fuel lines, fuel caps, valves, canisters, filters, vapor hoses, clamps, connectors, and other associated emission-related components.

Where a warrantable condition exists, The Toro Company will repair your small off-road engine at no cost to you including diagnosis, parts and labor.

### Manufacturer's Warranty Coverage

The Toro Company and its affiliate, Toro Warranty Company, pursuant to an agreement between them, jointly warrant the 2012 small off-road engine for two years from the date of delivery. If any evaporative emission-related part on your equipment is defective, the part will be repaired or replaced by The Toro Company.

### Owner Responsibilities

As the small off-road engine owner, you are responsible for the performance of the required maintenance listed in your *Operator's Manual*. We recommend that you retain all receipts covering maintenance on your small off-road engine, but we cannot deny warranty solely for the lack of receipts.

As the small off-road engine owner, you should however be aware that we may deny you warranty coverage if your small off-road engine or a part has failed due to abuse, neglect, improper maintenance or unapproved modifications.

You are responsible for presenting your small off-road engine to an Authorized Service Dealer as soon as a problem exists. The warranty repairs should be completed in a reasonable amount of time, not to exceed thirty (30) days.

If you have any questions regarding your warranty coverage, contact us at:

Customer Care Department, Consumer Division  
Toro Warranty Company  
8111 Lyndale Avenue South  
Bloomington, MN 55420-1196  
Toll free at 800-348-2424 (U.S. customers)  
Toll free at 800-544-5364 (Canadian customers)

### General Emissions Warranty Coverage

The Toro Company and its affiliate, Toro Warranty Company, jointly warrant to the initial owner and each subsequent purchaser that the small off-road engine is:

Designed built and equipped to as to conform with all applicable regulations; and

Free from defects in materials and workmanship that cause the failure of a warranted part to be identical in all material respect to that part as described in The Toro Company application for certification.

The warranty period begins on the date the small off-road engine is delivered to an ultimate purchaser. The warranted period is two years.

Subject to certain conditions and exclusions as stated below, the warranty on evaporative emissions-related parts is as follows:

1. Any warranted part that is not scheduled for replacement as required maintenance in the written instructions supplied, is warranted for the warranty period stated above. If the part fails during the period of warranty coverage, the part will be repaired or replaced by The Toro Company. Any such part repaired or replaced under warranty will be warranted for the remainder of the warranty period.
2. Any warranted part that is scheduled only for regular inspection in the written instructions supplied is warranted for the warranty period stated above. Any such part repaired or replaced under the warranty will be warranted for the remainder of the warranty period.
3. Any warranted part that is scheduled for replacement as required maintenance in the written instructions supplied is warranted for the period of time before the first scheduled replacement date for that part. If the part fails before the first scheduled replacement, the part will be repaired or replaced by The Toro Company. Any such part repaired or replaced under warranty will be warranted for the remainder of the period prior to the first scheduled replacement point for the part.
4. Repair or replacement of any warranted part under the warranty provisions herein must be performed at an Authorized Service Dealer at no charge to the owner.
5. Notwithstanding the provisions herein, warranty services or repairs will be provided at all Service Dealers authorized to service the subject engines or equipment.
6. The small off-road engine owner will not be charged for diagnostic labor that is directly associated with diagnosis of a defective, emission-related warranted part, provided that such diagnostic work is performed at an Authorized Service Dealer.
7. The Toro Company is liable for damages to other engine or equipment components proximately caused by a failure under warranty of any warranted part.
8. Throughout the small off-road engine warranty period stated above, The Toro Company will maintain a supply of warranted parts sufficient to meet the expected demand for such parts.
9. Manufacturer approved replacement parts may be used in the performance of any warranty maintenance or repairs and must be provided without charge to the owner. Such use will not reduce the warranty obligations of The Toro Company.
10. Add-on or modified parts that are not approved by The Toro Company may not be used. The use of a non-approved add-on or modified part by the purchaser will be grounds for disallowing a warranty claim. The Toro Company will not be liable to warrant failures of warranted parts caused by the use of a non-approved add-on or modified part.

### Warranted Parts

The repair or replacement of any warranted part otherwise eligible for warranty coverage may be excluded from such coverage warranty if The Toro Company demonstrates that the small off-road engine has been abused, neglected, or improperly maintained, and that such abuse, neglect, or improper maintenance was the direct cause of the need for repair or replacement of the part. That notwithstanding, any adjustment of a component that has a factory installed, and properly operation, adjustment limiting device is still eligible for warranty coverage. The following emission warranty parts list are covered:

Fuel Tank  
Fuel Cap

Pressure Relief Valves  
Control Valves

Control Cables  
Control Linkages

Carbon Canister  
Canister Mounting Brackets

Fuel Lines  
Fuel Line Fittings  
Clamps

Control Solenoids  
Electronic Controls  
Vacuum Control Diaphragms

Purge Valves  
Vapor Hoses  
Liquid/Vapor Separators

Carburetor purge Port Connector



## The Toro Total Coverage Warranty

Limited Warranty (see warranty periods below)

### Conditions and Products Covered

The Toro Company and its affiliate, Toro Warranty Company, pursuant to an agreement between them, jointly promise to the original purchaser to repair the Toro Products listed below if defective in materials or workmanship.

The following time periods apply from the date of purchase by the original owner:

<b>Products</b>	<b>Warranty Period</b>
TimeCutter and MX Mowers • Engines <sup>1</sup> — Residential use	Residential use <sup>2</sup> — 3 years Kawasaki — 3 years Kohler — 3 years Toro — 3 years
TimeCutter and MX Mowers • Engines <sup>1</sup> — Commercial use	Commercial use 30 days Kawasaki — 3 years Kohler — 90 days Toro — 90 days
TITAN Mowers — Residential or Commercial use • Engines <sup>1</sup> — Residential or Commercial use • Frame	3 years or 240 hours <sup>3</sup> Kawasaki — 3 years Kohler — 2 years Lifetime (original owner only) <sup>4</sup>
TITAN MX Mowers — Residential or Commercial use • Engines <sup>1</sup> — Residential or Commercial use • Frame	3 years or 400 hours <sup>3</sup> Kawasaki — 3 years Kohler — 2 years Lifetime (original owner only) <sup>4</sup>
<b>All Mowers</b>	
• Attachments	1 year
• Battery	90 days Parts and Labor 1 year Parts only
• Belts and Tires	90 days

<sup>1</sup>Some engines used on Toro Products are warranted by the engine manufacturer.

<sup>2</sup>Residential use means use of the product on the same lot as your home. Use at more than one location is considered commercial use and the commercial use warranty would apply.

<sup>3</sup>Whichever occurs first.

<sup>4</sup>Lifetime Frame Warranty - If the main frame, consisting of the parts welded together to form the tractor structure that other components such as the engine are secured to, cracks or breaks in normal use, it will be repaired or replaced, at Toro's option, under warranty at no cost for parts and labor. Frame failure due to misuse or abuse and failure or repair required due to rust or corrosion are not covered.

This warranty includes the cost of parts and labor, but you must pay transportation costs.

Warranty may be denied if the hour meter is disconnected, altered, or shows signs of being tampered with.

### Owner Responsibilities

You must maintain your Toro Product by following the maintenance procedures described in the *Operator's Manual*. Such routine maintenance, whether performed by a dealer or by you, is at your expense.

### Instructions for Obtaining Warranty Service

If you think that your Toro Product contains a defect in materials or workmanship, follow this procedure:

1. Contact any Authorized Toro Service Dealer to arrange service at their dealership. To locate a dealer convenient to you, refer to the *Yellow Pages* of your telephone directory (look under "Lawn Mowers") or access our web site at [www.Toro.com](http://www.Toro.com). You may also call the numbers listed in item #3 to use the 24-hour Toro Dealer locator system.
2. Bring the product and your proof of purchase (sales receipt) to the Service Dealer. The dealer will diagnose the problem and determine if it is covered under warranty.
3. If for any reason you are dissatisfied with the Service Dealer's analysis or with the assistance provided, contact us at:

Customer Care Department, RLC Division  
Toro Warranty Company  
8111 Lyndale Avenue South  
Bloomington, MN 55420-1196  
Toll free at 866-216-6029 (U.S. customers)  
Toll free at 866-216-6030 (Canadian customers)

### Items and Conditions Not Covered

There is no other express warranty except for special emission system coverage and engine warranty coverage on some products. This express warranty does not cover the following:

- Cost of regular maintenance service or parts, such as filters, fuel, lubricants, oil changes, spark plugs, air filters, blade sharpening/worn blade on mowers, cable/linkage adjustments, or brake and clutch adjustments
- Components failing due to normal wear
- Any product or part which has been altered or misused and requires replacement or repair due to accidents or lack of proper maintenance
- Repairs necessary due to improper battery care, failure to use fresh fuel (less than one month old), or failure to properly prepare the unit prior to any period of non-use over one month
- Pickup and delivery charges
- Operational misuse, neglect, or accidents
- Repairs or attempted repairs by anyone other than an Authorized Toro Service Dealer

### General Conditions

All repairs covered by these warranties must be performed by an Authorized Toro Service Dealer using Toro approved replacement parts.

**Neither The Toro Company nor Toro Warranty Company is liable for indirect, incidental or consequential damages in connection with the use of the Toro Products covered by this warranty, including any cost or expense of providing substitute equipment or service during reasonable periods of malfunction or non-use pending completion of repairs under this warranty.**

**All implied warranties of merchantability (that the product is fit for ordinary use) and fitness for use (that the product is fit for a particular purpose) are limited to the duration of the express warranty.**

**Some states do not allow exclusions of incidental or consequential damages, or limitations on how long an implied warranty lasts, so the above exclusions and limitations may not apply to you.**

This warranty gives you specific legal rights, and you may also have other rights which vary from state to state.

### Countries Other than the United States or Canada

Customers who have purchased Toro products outside the United States or Canada should contact their Toro Distributor (Dealer) to obtain guarantee policies for your country, province, or state. If for any reason you are dissatisfied with your Distributor's service or have difficulty obtaining guarantee information, contact the Toro importer. If all other remedies fail, you may contact us at Toro Warranty Company.