



Count on it.

Parts Catalog

**TimeCutter® ZS 3200 Riding
Mower**

Model No. 74385—Serial No. 31200001 and Up

Ordering Replacement Parts

To order replacement parts, please supply the part number, the quantity, and the description of each part desired.

Understanding Reference Numbers

Each identified part in an illustration has a reference number. The reference number for a part also appears in the parts list, along with other information about the part.

This catalog uses two special reference number formats, one to indicate parts in a service assembly and another to indicate the quantity of a given part in an illustration.

Service Assembly Reference Numbers

Parts in service assemblies have reference numbers in the form a:b. The a represents the reference number of the entire service assembly and the b represents a sequential number unique to each part within the service assembly.

For example, a wheel assembly might be identified by reference number 6, the tire by 6:1, the valve by 6:2, and the wheel by 6:3. When you order the assembly identified by reference number 6, you receive all parts identified by reference numbers 6:1, 6:2, and 6:3. However, you may also order any part individually. Reference numbers of this type appear in illustration and in parts lists.

Reference Numbers Indicating Quantity

In an illustration, if a reference number indicates more than one part, the reference number has the form nX y. The n represents the quantity of the part, the X is the multiplication symbol, and the y represents the reference number.

For example, in an illustration, the reference number 2X 37 means that two of the parts identified by reference number 37 are indicated.

List of Abbreviations

AR: as required

ASM: assembly

BBC: blade brake control

BHTF: button head thread forming

CARR: carriage

CCW: counter clockwise

CW: clockwise

DEG: degrees

DPA: Dual Point Adjustment

ECM: electronic control module

EXT: external

FH: flat head

GA: gauge

HD: heavy-duty

HF: hex flange

HH: hex head

HHF: hex head flange

HHFTF: hex head flange thread forming

HJ: hex jam

HLH: hex lag head

HOC: height-of-cut

HSBH: hex socket button head

HSFH: hex socket flat head

HSH: hex socket head

HWH: hex washer head

HWHTF: hex washer head thread forming

HYD: hydraulic

LH: left hand

LP: Liquid Propane

NI: nylon insert

NPTF: national pipe thread fine

PFH: phillips flat head

PPH: phillips pan head

PPHTF: phillips pan head thread forming

PRH: phillips round head

PTH: phillips truss head

PTO: power-take-off

RH: right hand

ROPS: roll-over protection system

RRB: rear roller brush

SFH: slotted fillister head

SHH: slotted hex head

SHWH: slotted hex washer head

SPH: slotted pan head

SQH: square head

SRH: slotted round head

STD: standard

TAP: self tapping

TTH: torx truss head

Contents

Main Frame and Caster Wheel Assembly	4
Caster Wheel Assembly No. 120-5515.....	5
Caster Wheel Assembly No. 110-6785.....	6
Seat Assembly	7
Motion Control Assembly	8
Belt and Idler Assembly.....	10
Hydro Transaxle Assembly.....	11
Right Hand Hydro Transaxle Assembly No. 119-3331	12
Left Hand Hydro Transaxle Assembly No. 119-3330	14
Clutch Assembly.....	16
Engine and Exhaust Assembly.....	17
Body Styling and Fuel Pod Assembly	18
Fuel Delivery Assembly.....	19
Electrical Assembly	20
Deck Lift Assembly.....	21
32 Inch Deck Assembly.....	22
32 Inch Deck Baffle Assembly	23
32 Inch Deck, Belt and Blade Assembly.....	24
Attachments and Accessories	25

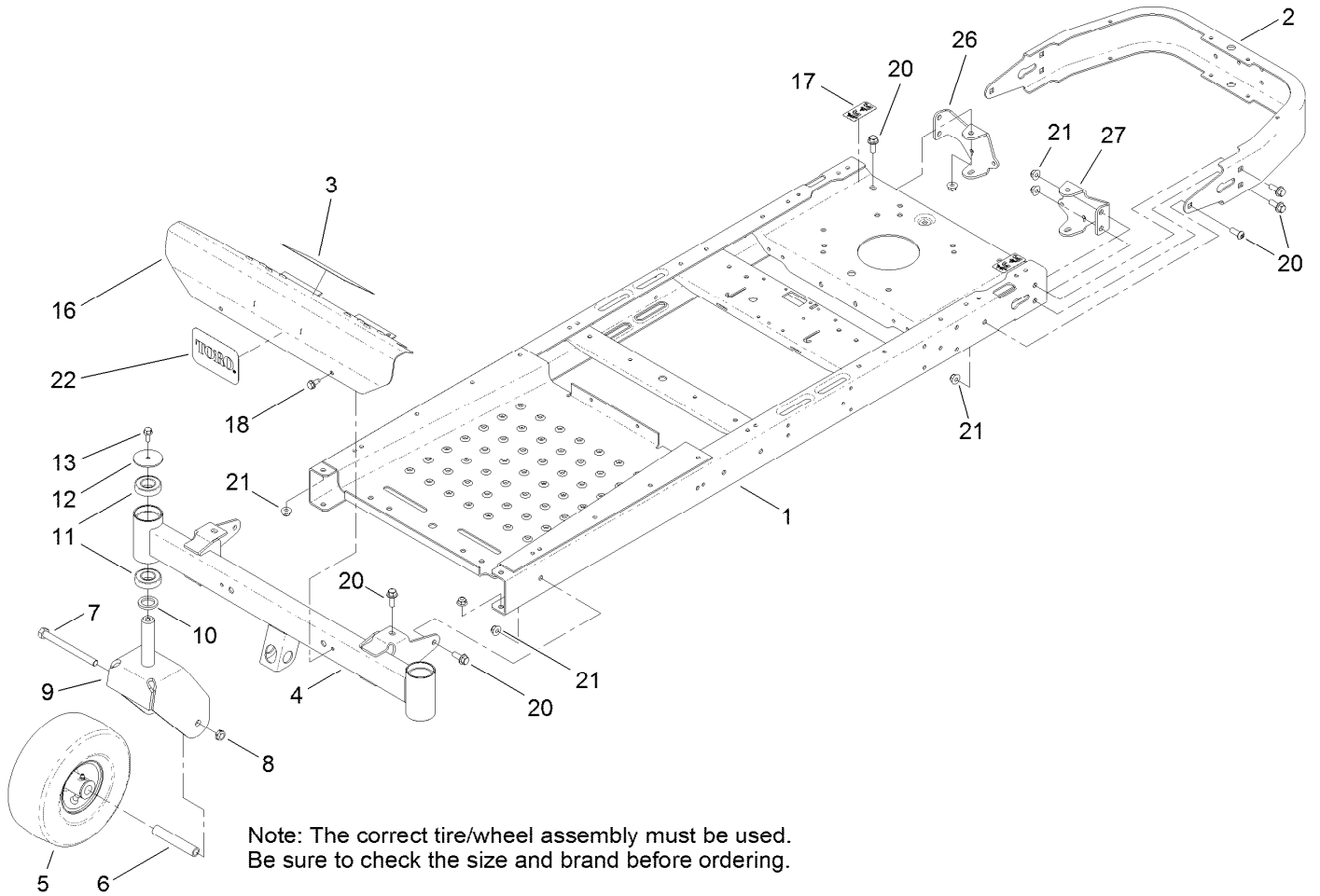

Main Frame and Caster Wheel Assembly

Ref.	Part Number	Qty.	Description	Ref.	Part Number	Qty.	Description
1	121-2972-01	1	Frame	12	119-8915	2	Washer
2	110-1920-01	1	Bumper-Rear	13	3234-47	2	Screw-HHF
3	120-2239	1	Decal-Danger	16	117-7332-03	1	Footrest
4	120-5516-01	1	Axle-Front	17	121-2989	2	Decal-Bypass
5	120-5515	2	Caster Wheel ASM (Cst)	18	32144-70	2	Screw-HWHTF
5	110-6785	2	Caster Wheel ASM (Kenda)	20	3234-42	12	Screw-HHF
6	104-3667	2	Spanner-Wheel	20	3274-94	2	Screw-HSBH
7	325-22	2	Screw-HH	21	104-8301	14	Nut-Flange, NI
8	3296-45	2	Nut-Lock, NI	22	105-8278	1	Decal
9	120-2266-01	2	Fork-Caster	26	121-0737-01	1	Mount-Hydro, Rear RH
10	117-7394	2	Washer-Thrust	27	121-0738-01	1	Mount-Hydro, Rear LH
11	109-3678	4	Bearing-Ball				

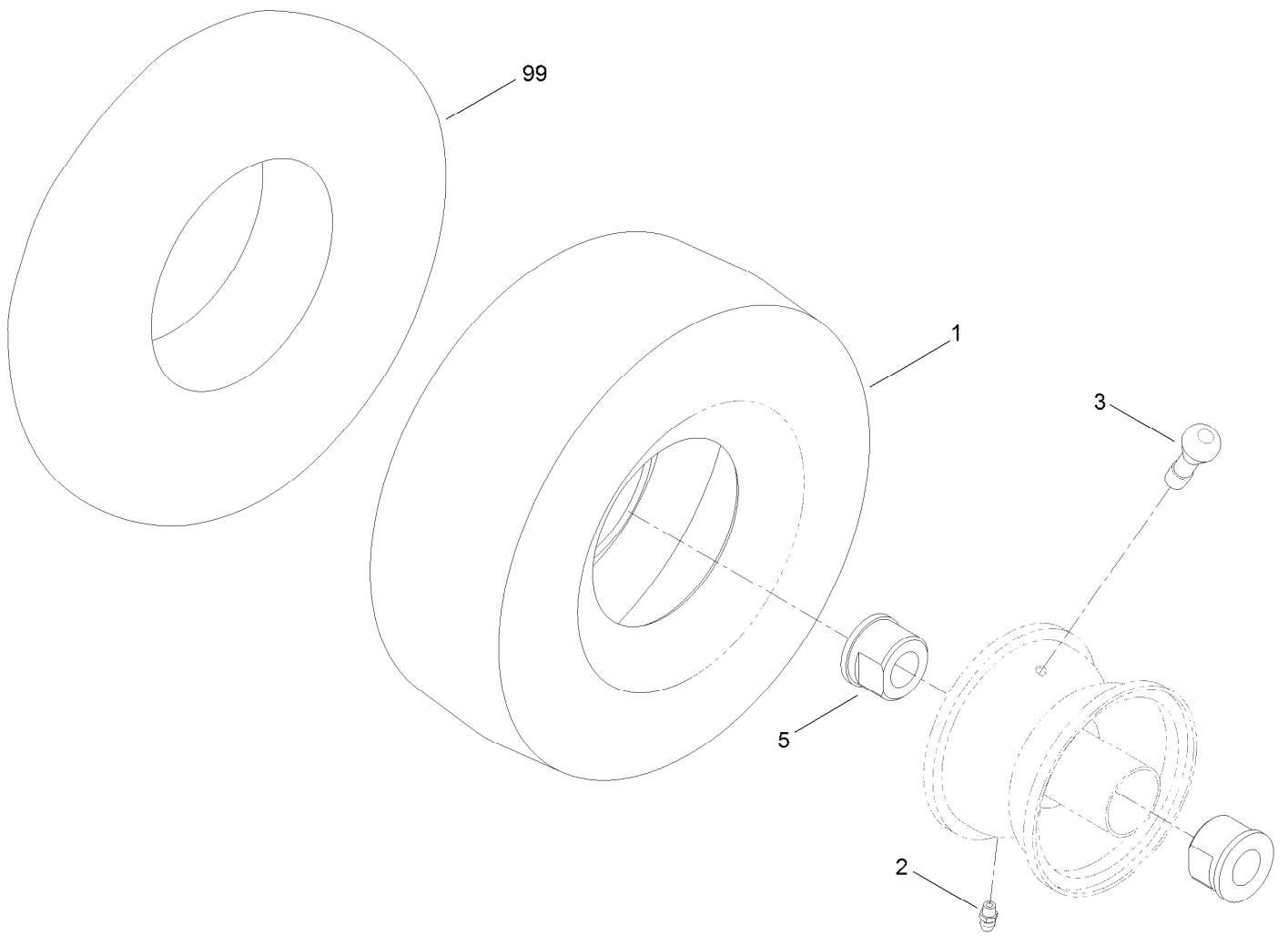

Caster Wheel Assembly No. 120-5515

<i>Ref.</i>	<i>Part Number</i>	<i>Qty.</i>	<i>Description</i>
1	120-5514	1	Tire-Smooth (Cst)
2	302-5	1	Fitting-Grease
3	232-27	1	Stem-Valve
5	114-1640	2	Bushing-Flange
99	93-4244	1	Tube-Inner (W/Valve)

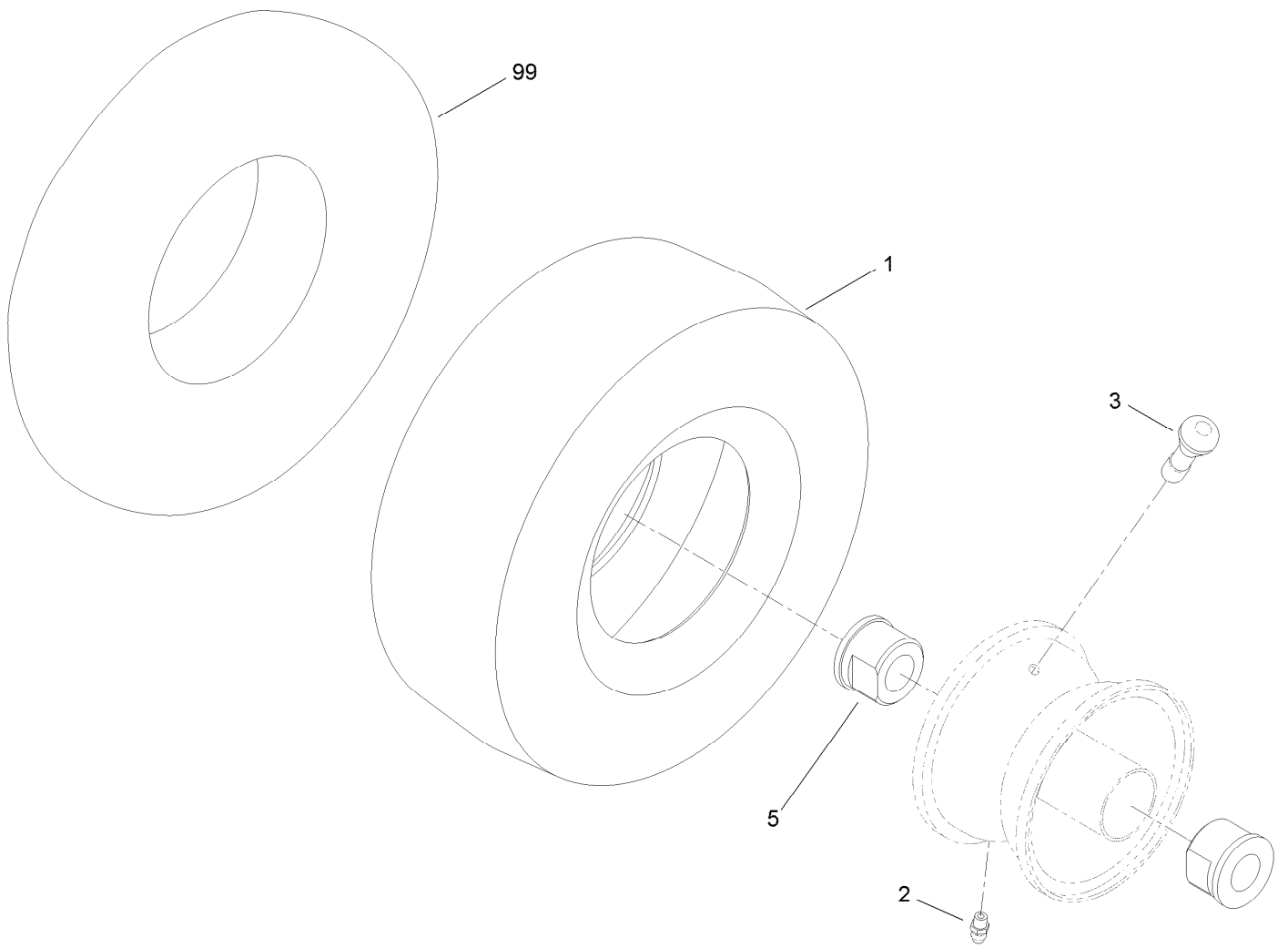

Caster Wheel Assembly No. 110-6785

<i>Ref.</i>	<i>Part Number</i>	<i>Qty.</i>	<i>Description</i>
1	110-6791	1	Tire-Smooth (Kenda)
2	302-5	1	Fitting-Grease
3	232-27	1	Stem-Valve
5	114-1640	2	Bushing-Flange
99	93-4244	1	Tube-Inner (W/Valve)

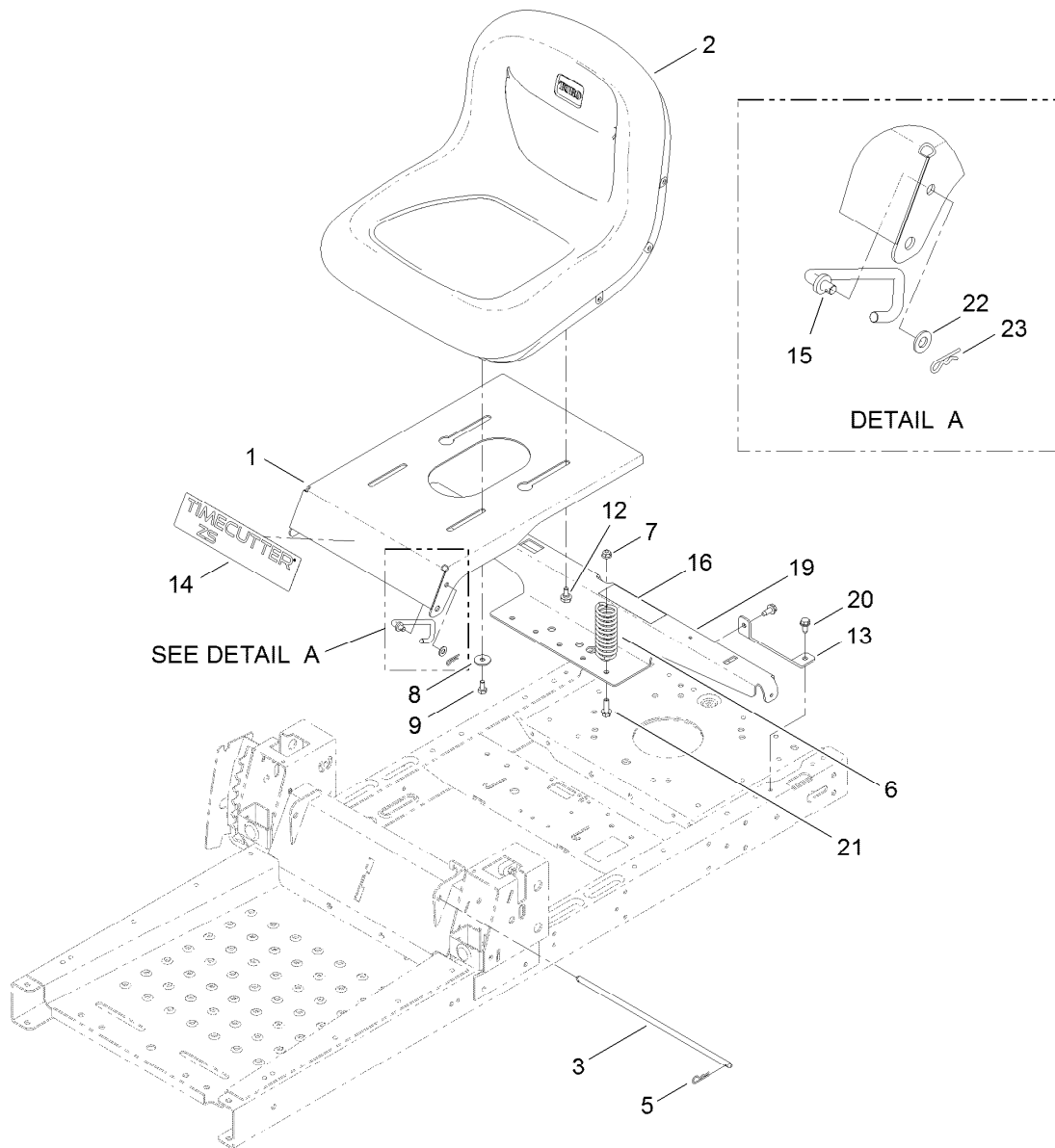

Seat Assembly

Ref.	Part Number	Qty.	Description	Ref.	Part Number	Qty.	Description
1	119-3391-01	1	Pan-Seat	13	119-3431-03	2	Support-Tank, Rear
2	119-8828	1	Seat-15 Inch	14	120-5450	1	Decal-Timecutter
3	119-3433	1	Rod-Pivot, Narrow	15	119-8972	1	Stop-Seat
5	3290-250	2	Pin-Hair	16	106-8717	1	Decal-Service
6	92-7054	3	Spring-Compression	19	121-0732-03	1	Support-Pod
7	104-8300	3	Nut-Flange, NI	20	32144-70	4	Screw-HWHTF
8	5-4460	2	Washer-Pivot	21	3234-29	3	Screw-HHF
9	322-2	2	Screw-HH	22	3256-23	1	Washer-Flat
12	37-8771	2	Bolt-Shoulder	23	3290-307	1	Pin-Hair

Motion Control Assembly

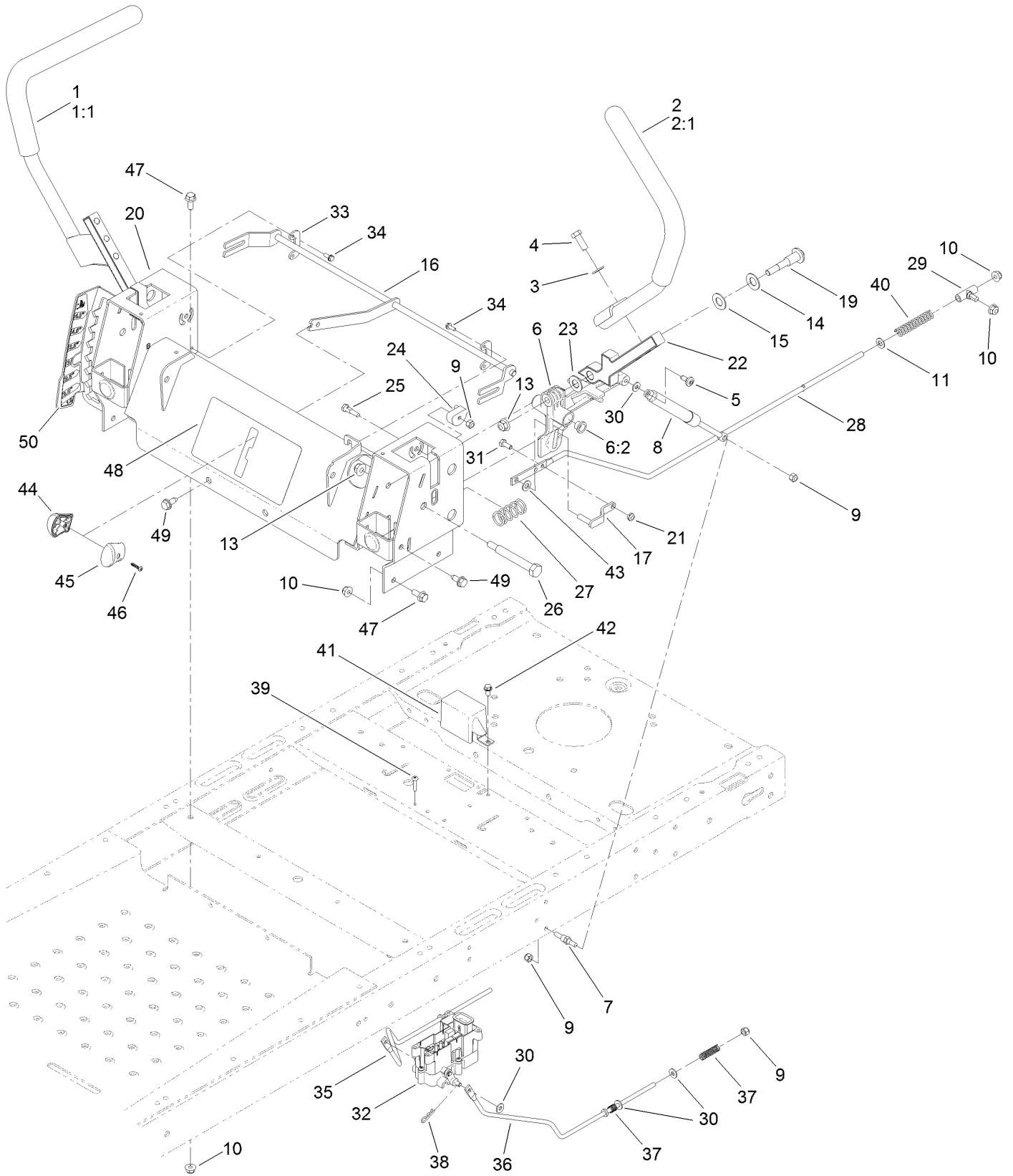

Motion Control Assembly (continued)

<i>Ref.</i>	<i>Part Number</i>	<i>Qty.</i>	<i>Description</i>	<i>Ref.</i>	<i>Part Number</i>	<i>Qty.</i>	<i>Description</i>
1	121-0731	1	Handle-Control, RH	26	115-5099	2	Bolt-Pivot
1:1	121-0726	1	Grip	27	119-8876	2	Spring-Return
2	121-0730	1	Handle-Control, LH	28	117-5388	2	Rod-Hydro
2:1	121-0726	1	Grip	29	119-8842	2	Mount-Rod, Hydro
3	3256-24	4	Washer-Flat	30	119-8952	8	Washer
4	323-6	4	Screw-HH	31	321-3	2	Screw-HH
5	120-7950	2	Screw-Shoulder	32	121-3017	1	Brake Control Module ASM
6	119-3470	2	Actuator Arm ASM	33	117-5385	2	Retainer
6:2	256-156	2	Bushing-Flange	34	32144-1	4	Screw-Taptite
7	110-6810	2	Stud-Damper	35	121-2974	1	Rod-Brake, RH
8	103-2913	2	Damper-Control, Motion	36	121-2975	1	Rod-Brake, LH
9	3296-42	8	Nut-Lock, NI	37	117-1169	4	Spring-Compression
10	104-8300	10	Nut-Flange, NI	38	3290-307	2	Pin-Hair
11	3256-23	2	Washer-Flat	39	32144-36	4	Screw-PPH
13	104-8301	4	Nut-Flange, NI	40	1-603807	2	Spring-Return, Neutral
14	119-8925	2	Washer-Belleville	41	119-8859	1	Cover-Brake
15	117-1240	2	Washer	42	32144-4	1	Screw-HWH
16	119-8832	1	Control-Speed	43	93-6079	2	Spacer-Nylon
17	119-3303	2	Pin-Rod, Hydro	44	119-8935	1	RH Knob ASM
19	117-1198	2	Bolt-Pivot	45	119-8936	1	LH Knob ASM
20	119-3386-03	1	Box-Control	46	94-4496	1	Screw-PPH
21	3296-56	2	Nut-Lock, NI	47	3234-47	6	Screw-HHF
22	115-5098-05	2	Lever-Control	48	120-5468	1	Decal-Speed Control
23	120-2273	2	Washer-Nylon	49	32144-70	4	Screw-HWHTF
24	115-9604	2	Eccentric	50	120-5469	1	Decal-HOC
25	119-3301	2	Bolt-Pivot, Eccentric				

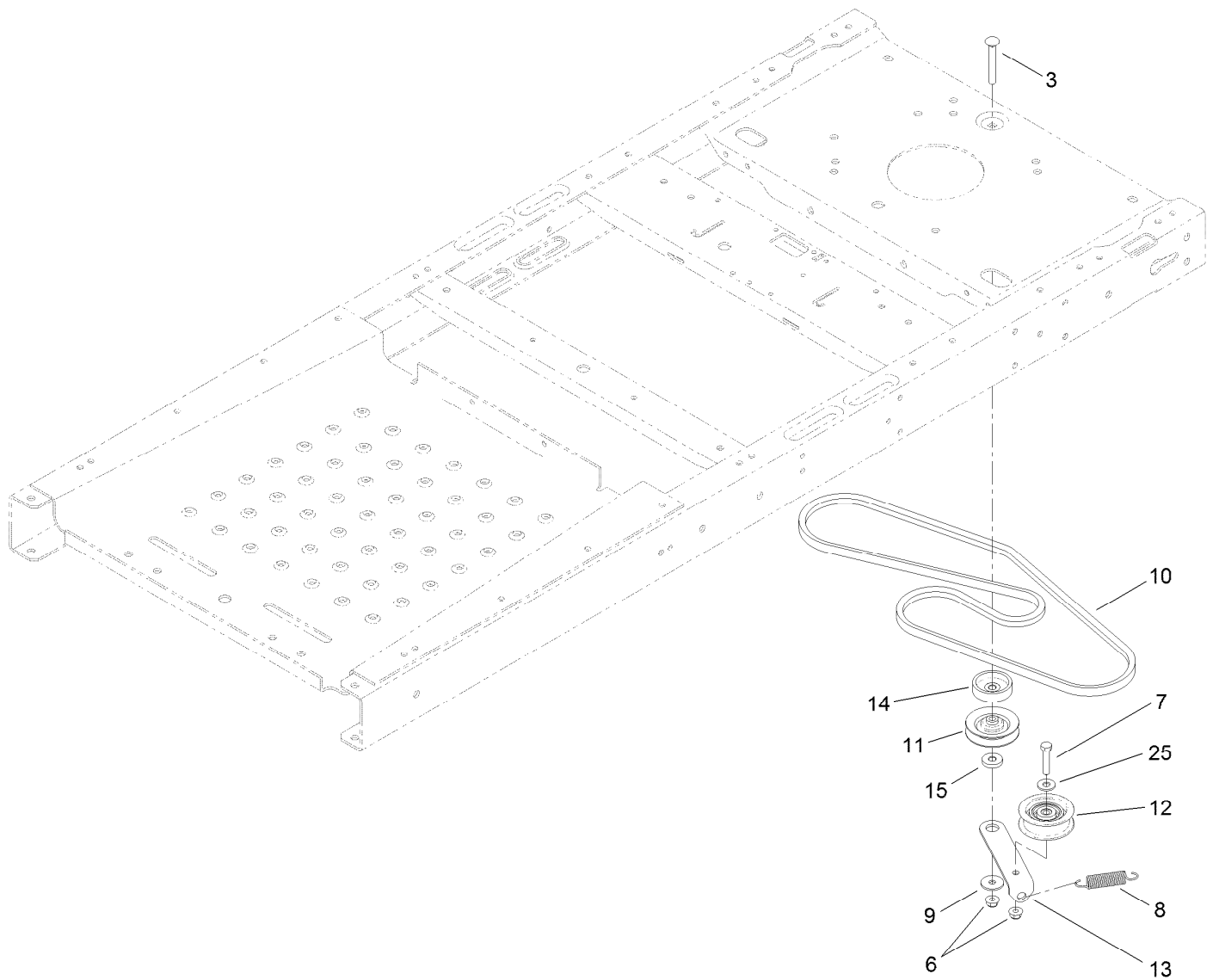

Belt and Idler Assembly

Ref.	Part Number	Qty.	Description
3	3230-8	1	Screw-CARR
6	104-8300	2	Nut-Flange, NI
7	322-7	1	Screw-HH
8	104-6415	1	Spring-Return, Pedal
9	5-4460	1	Washer-Pivot
10	119-3309	1	V-Belt
11	119-8822	1	Pulley-Idler
12	106-2176	1	Pulley-Idler
13	119-3326	1	Arm-Idler
14	119-3353	1	Spacer
15	119-3327	1	Spacer-Arm, Idler
25	3256-3	1	Washer-Flat

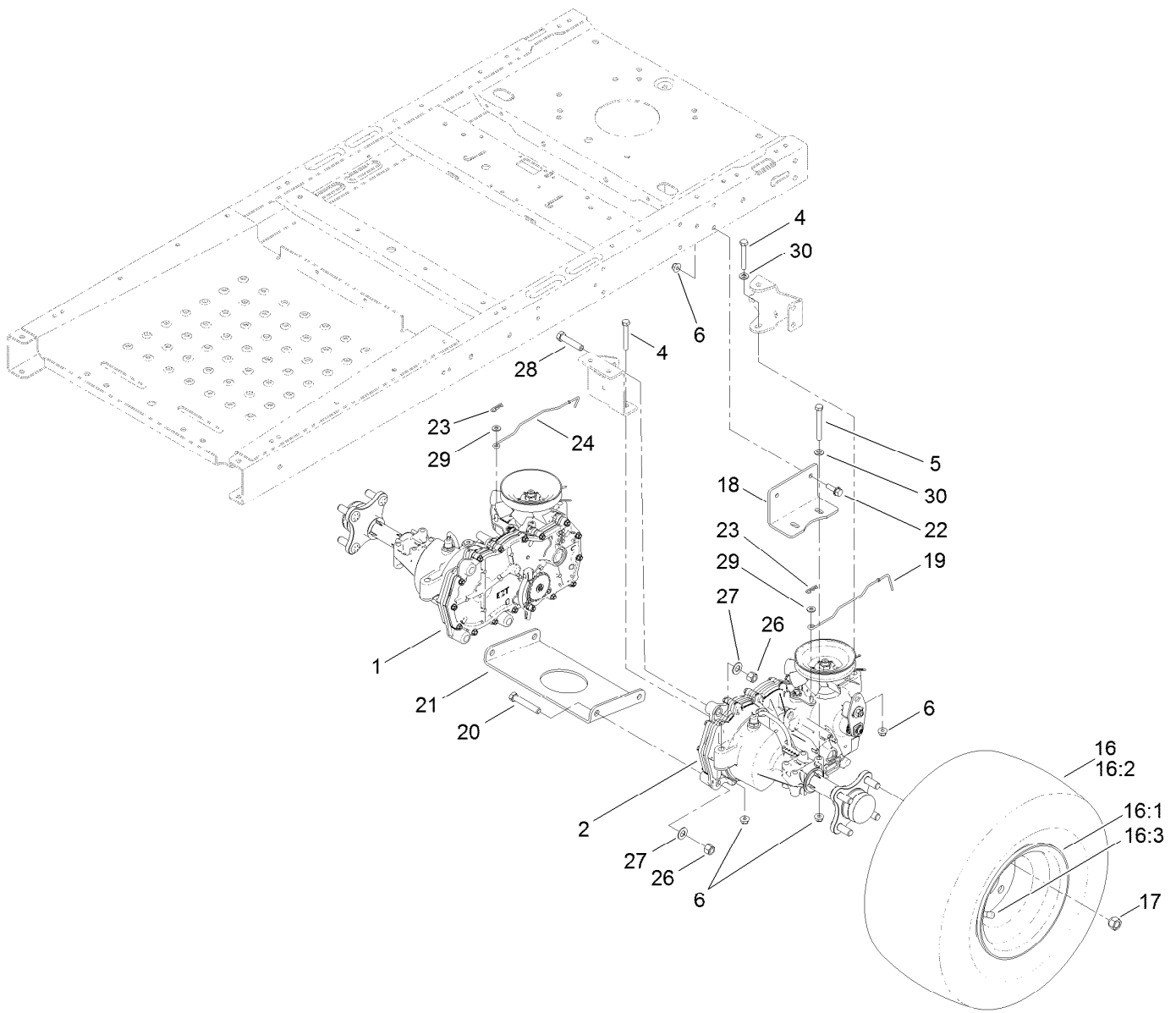

Hydro Transaxle Assembly

<i>Ref.</i>	<i>Part Number</i>	<i>Qty.</i>	<i>Description</i>	<i>Ref.</i>	<i>Part Number</i>	<i>Qty.</i>	<i>Description</i>
1	119-3331	1	Transaxle-Hydro, RH	19	121-2971	1	Rod-Bypass, LH
2	119-3330	1	Transaxle-Hydro, LH	20	324-10	4	Screw-HH
4	322-11	4	Screw-HH	21	119-3339-03	1	Plate-Cross, Hydro
5	322-13	4	Screw-HH	22	3234-29	4	Screw-HHF
6	104-8300	12	Nut-Flange, NI	23	3290-307	2	Pin-Hair
16	119-3422	2	Wheel And Tire ASM	24	121-0752	1	Rod-Bypass, RH
16:1	119-3423	1	Wheel	26	3296-48	6	Nut-Lock, NI
16:2	119-3421	1	Tire	27	3256-25	6	Washer-Flat
16:3	232-27	1	Stem-Valve	28	324-8	2	Screw-HH
17	242-50	8	Nut-Lug	29	3256-22	2	Washer-Flat
18	117-7264-03	2	Mount-Hydro	30	3256-23	6	Washer-Flat

Right Hand Hydro Transaxle Assembly No. 119-3331

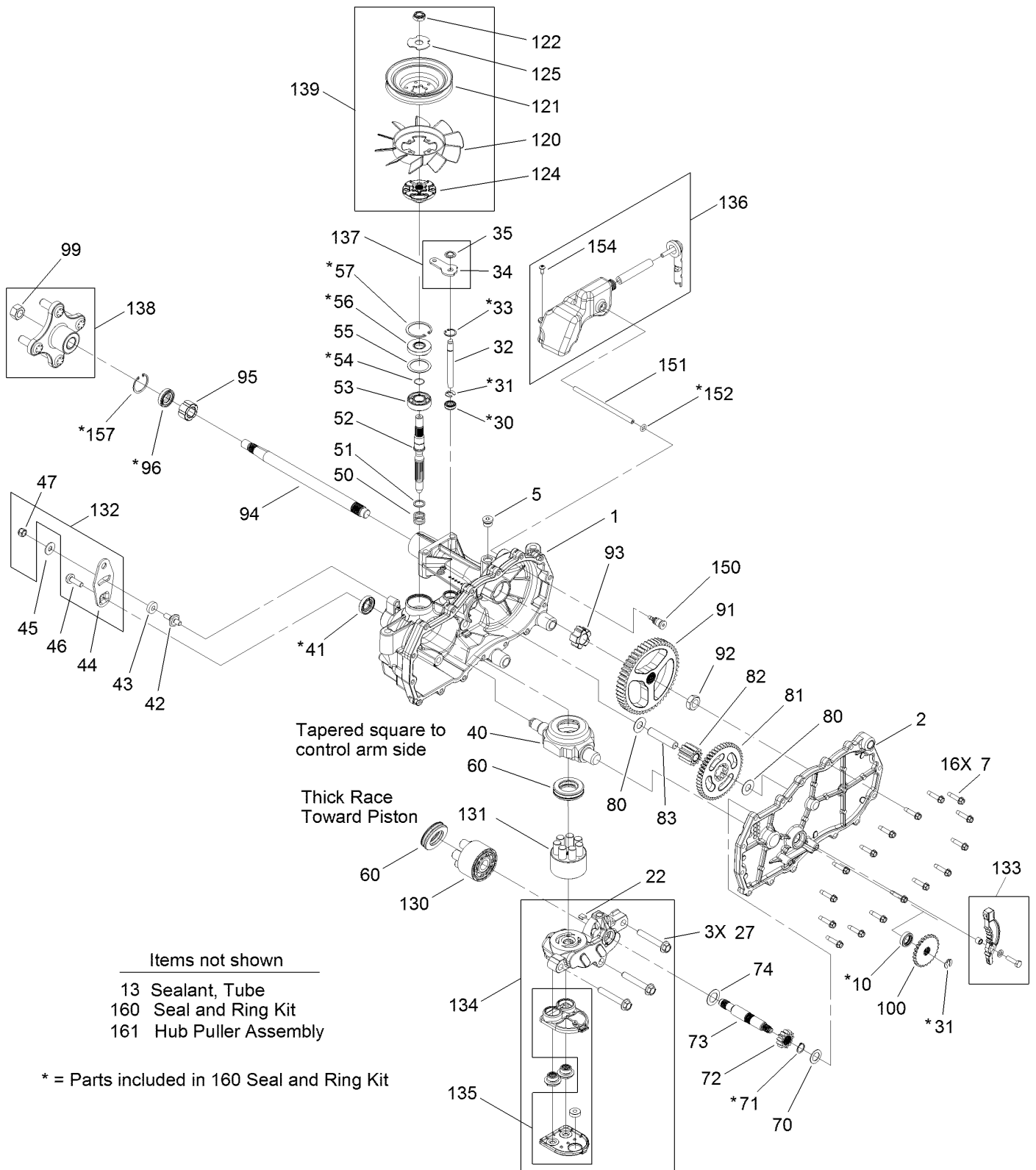

Items not shown

- 13 Sealant, Tube
- 160 Seal and Ring Kit
- 161 Hub Puller Assembly

* = Parts included in 160 Seal and Ring Kit

Right Hand Hydro Transaxle Assembly No. 119-3331 (continued)

<i>Ref.</i>	<i>Part Number</i>	<i>Qty.</i>	<i>Description</i>	<i>Ref.</i>	<i>Part Number</i>	<i>Qty.</i>	<i>Description</i>
1	120-5531	1	Main Housing ASM	74	104-5360	1	Washer-Shaft, Motor
2	120-5533	1	Housing Side Kit	80	119-5541	2	Washer
5	104-2189	1	Plug-Thread, Straight	81	104-5317	1	Gear
7	117-5359	16	Screw-Hfhcs	82	104-5318	1	Gear-Jackshaft, 10T
10	120-5535	1	Seal-Lip	83	104-5329	1	Pin-Jackshaft
13	104-2147	1	Sealant ●	91	120-5539	1	Gear-Bull
22	114-1680	1	Plate-Bypass	92	104-2142	1	Nut-HJ
27	120-5536	3	Bolt-Hex Flange	93	115-8314	1	Bushing-Inboard
30	106-8676	1	Seal-Lip	94	120-5540	1	Shaft-Axle
31	106-8677	1	Ring-Retaining, EXT	95	120-5541	1	Bearing-Sleeve
32	106-8678	2	Rod-Bypass	96	120-5542	1	Seal-Lip
33	106-8679	1	Ring-Retaining, Int	99	120-5543	1	Nut-Hex Lock
34	107-2490	1	Arm-Bypass	100	106-8694	1	Disc-Brake, Cog
35	106-8681	1	Ring-Retaining, EXT	120	120-5544	1	Fan-6 Inch
40	104-5304	1	Swashplate-Trunnion	121	120-5545	1	Pulley
41	104-5313	1	Seal-Lip	122	105-1875	1	Nut-Lock
42	104-2116	1	Stud	124	120-5546	1	Hub
43	112-9853	1	Puck-Friction	125	107-9122	1	Washer-Slotted
44	106-8747	1	Arm-Control	130	103-2666	1	Cylinder Block Kit
45	114-8491	1	Washer	131	110-8561	1	Pump Block ASM
46	107-2488	1	Screw	132	117-5362	1	Arm Control Kit
47	105-1872	1	Nut	133	106-8688	1	Brake Arm Kit
50	120-5537	1	Spring-Compression	134	112-9862	1	Center Section Filter Kit
51	120-5538	1	Washer	135	114-1634	1	Filter Kit
52	104-5306	1	Shaft-Input	136	120-5547	1	Expansion Tank Kit
53	104-5311	1	Bearing-Ball	137	107-2489	1	Bypass Arm Kit
54	104-5307	1	Ring-Retaining	138	120-7101	1	Hub Kit
55	104-5308	1	Spacer	139	105-1928	1	Fan Pulley Kit
56	104-5310	1	Seal-Lip	150	104-5349	1	Fitting-Sae
57	104-5309	1	Ring-Retaining	151	115-8302	1	Hose
60	94-6922	1	Bearing-Thrust	152	104-5361	1	O-Ring
70	104-5339	1	Washer-Flat	154	120-7100	1	Bolt-Self Tapping
71	104-5340	1	Ring-Retaining	157	120-7102	1	Ring-Retaining
72	104-5316	1	Gear-Pinnion, 13T	160	120-7103	1	Seal And Ring Kit ●
73	106-8683	1	Shaft-Motor	161	114-8467	1	Hub-Puller, 4 Bolt ●

● Not illustrated

Left Hand Hydro Transaxle Assembly No. 119-3330

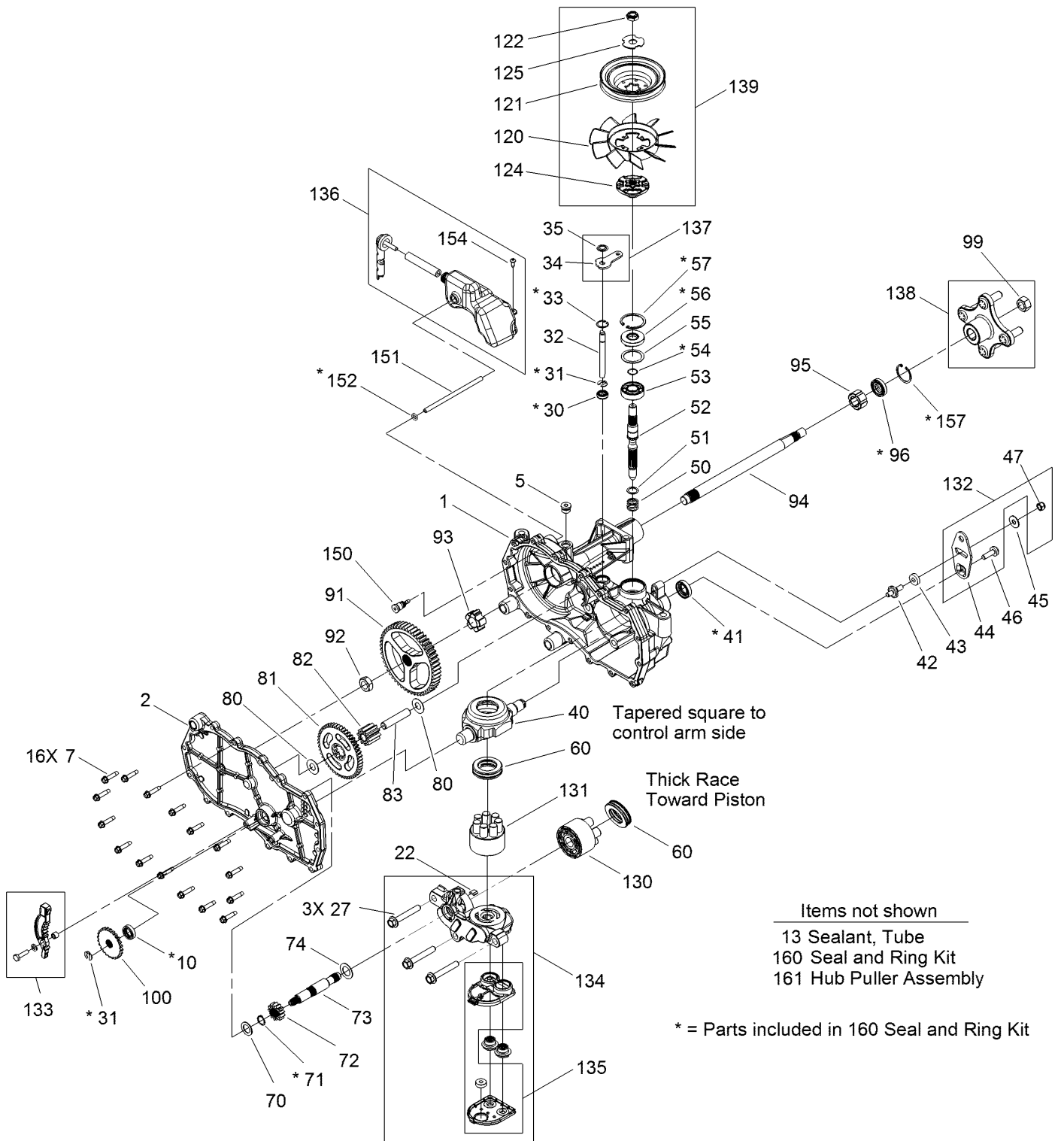

Left Hand Hydro Transaxle Assembly No. 119-3330 (continued)

<i>Ref.</i>	<i>Part Number</i>	<i>Qty.</i>	<i>Description</i>	<i>Ref.</i>	<i>Part Number</i>	<i>Qty.</i>	<i>Description</i>
1	120-5532	1	RH Main Housing ASM	74	104-5360	1	Washer-Shaft, Motor
2	120-5534	1	RH Housing Side Kit	80	119-5541	2	Washer
5	104-2189	1	Plug-Thread, Straight	81	104-5317	1	Gear
7	117-5359	16	Screw-Hfhcs	82	104-5318	1	Gear-Jackshaft, 10T
10	120-5535	1	Seal-Lip	83	104-5329	1	Pin-Jackshaft
13	104-2147	1	Sealant ●	91	120-5539	1	Gear-Bull
22	114-1680	1	Plate-Bypass	92	104-2142	1	Nut-HJ
27	120-5536	3	Bolt-Hex Flange	93	115-8314	1	Bushing-Inboard
30	106-8676	1	Seal-Lip	94	120-5540	1	Shaft-Axle
31	106-8677	1	Ring-Retaining, EXT	95	120-5541	1	Bearing-Sleeve
32	106-8678	2	Rod-Bypass	96	120-5542	1	Seal-Lip
33	106-8679	1	Ring-Retaining, Int	99	120-5543	1	Nut-Hex Lock
34	107-2490	1	Arm-Bypass	100	106-8694	1	Disc-Brake, Cog
35	106-8681	1	Ring-Retaining, EXT	120	120-5544	1	Fan-6 Inch
40	104-5304	1	Swashplate-Trunnion	121	120-5545	1	Pulley
41	104-5313	1	Seal-Lip	122	105-1875	1	Nut-Lock
42	104-2116	1	Stud	124	120-5546	1	Hub
43	112-9853	1	Puck-Friction	125	107-9122	1	Washer-Slotted
44	106-8747	1	Arm-Control	130	103-2666	1	Cylinder Block Kit
45	114-8491	1	Washer	131	110-8561	1	Pump Block ASM
46	107-2488	1	Screw	132	117-5362	1	Arm Control Kit
47	105-1872	1	Nut	133	106-8688	1	Brake Arm Kit
50	120-5537	1	Spring-Compression	134	112-9861	1	Center Section Filter Kit
51	120-5538	1	Washer	135	114-1634	1	Filter Kit
52	104-5306	1	Shaft-Input	136	120-5548	1	Expansion Tank Kit
53	104-5311	1	Bearing-Ball	137	107-2489	1	Bypass Arm Kit
54	104-5307	1	Ring-Retaining	138	120-7101	1	Hub Kit
55	104-5308	1	Spacer	139	105-1928	1	Fan Pulley Kit
56	104-5310	1	Seal-Lip	150	104-5349	1	Fitting-Sae
57	104-5309	1	Ring-Retaining	151	115-8302	1	Hose
60	94-6922	1	Bearing-Thrust	152	104-5361	1	O-Ring
70	104-5339	1	Washer-Flat	154	120-7100	1	Bolt-Self Tapping
71	104-5340	1	Ring-Retaining	157	120-7102	1	Ring-Retaining
72	104-5316	1	Gear-Pinnion, 13T	160	120-7103	1	Seal And Ring Kit ●
73	106-8683	1	Shaft-Motor	161	114-8467	1	Hub-Puller, 4 Bolt ●

● Not illustrated

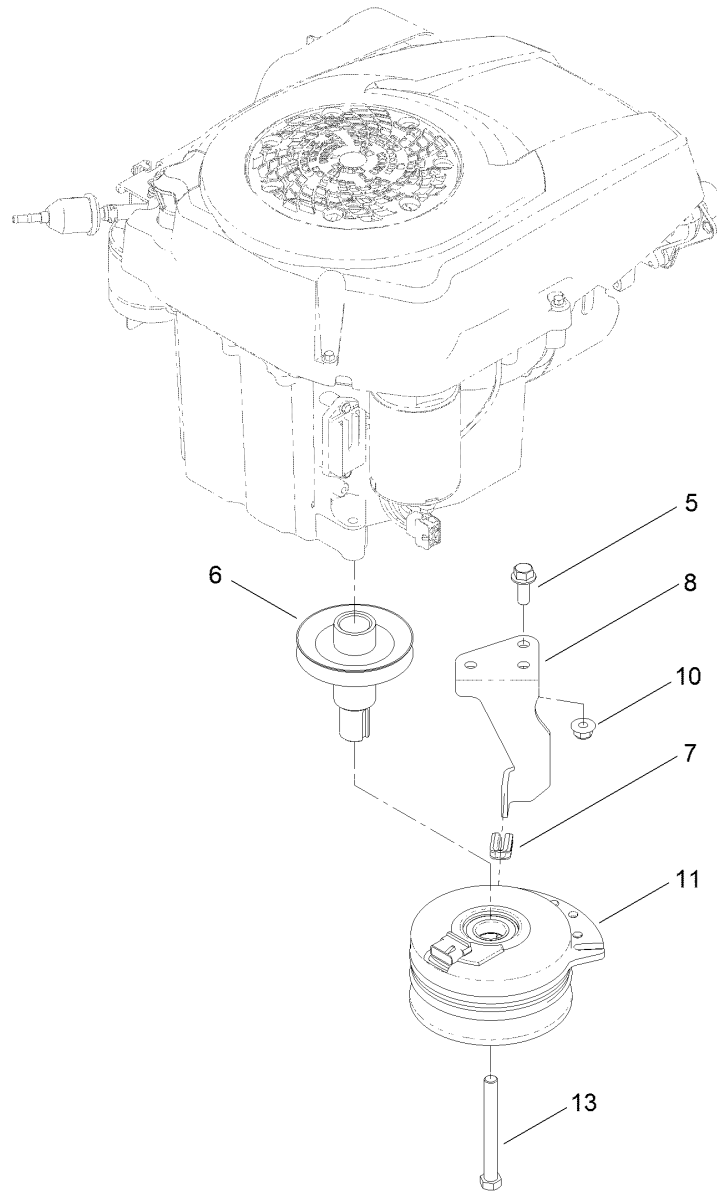

Clutch Assembly

<i>Ref.</i>	<i>Part Number</i>	<i>Qty.</i>	<i>Description</i>
5	3234-42	1	Screw-HHF
6	119-3318	1	Pulley-Engine
7	120-2217	1	Isolator-Clutch
8	119-8884	1	Stop-Clutch
10	104-8301	1	Nut-Flange, NI
11	117-7468	1	Clutch-Electric
13	3212-16	1	Screw-HH

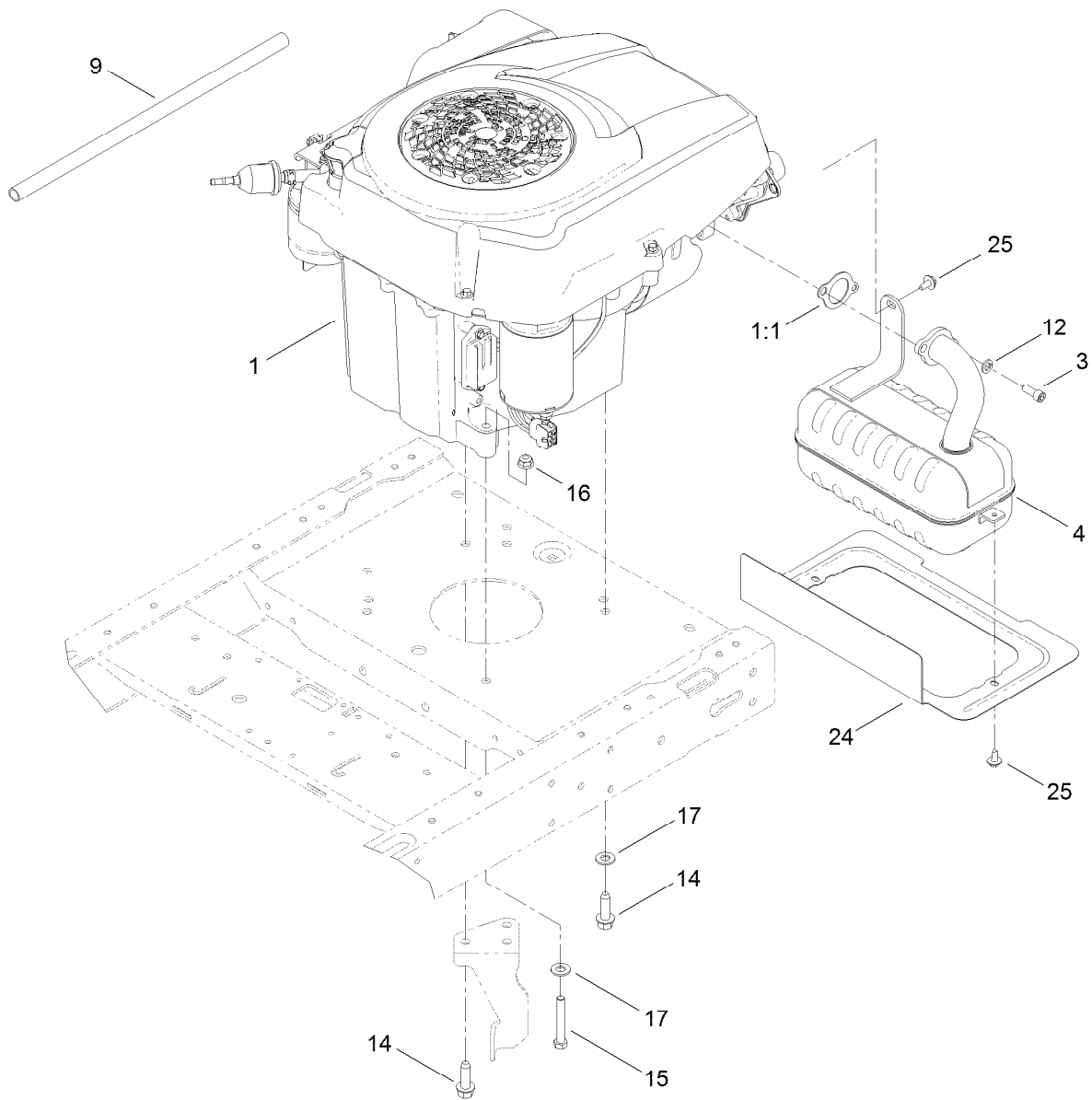

Engine and Exhaust Assembly

Ref.	Part Number	Qty.	Description
1		1	Engine-Kohler, Sv470-3222 ●■
1:1	110-6696	1	Gasket-Exhaust
3	3274-10	2	Screw-HSH
4	117-7312	1	Muffler-Kohler
9	106-7022	1	Tube-Drain, Oil
12	3253-4	2	Washer-Lock
14	32144-109	3	Screw
15	322-11	1	Screw-HH
16	104-8300	1	Nut-Flange, NI
17	3256-24	3	Washer-Flat
24	121-2973-03	1	Shield-Heat
25	46-8560	3	Screw-HHFTF

● Not serviced separately

■ Obtain parts from www.kohlerplus.com

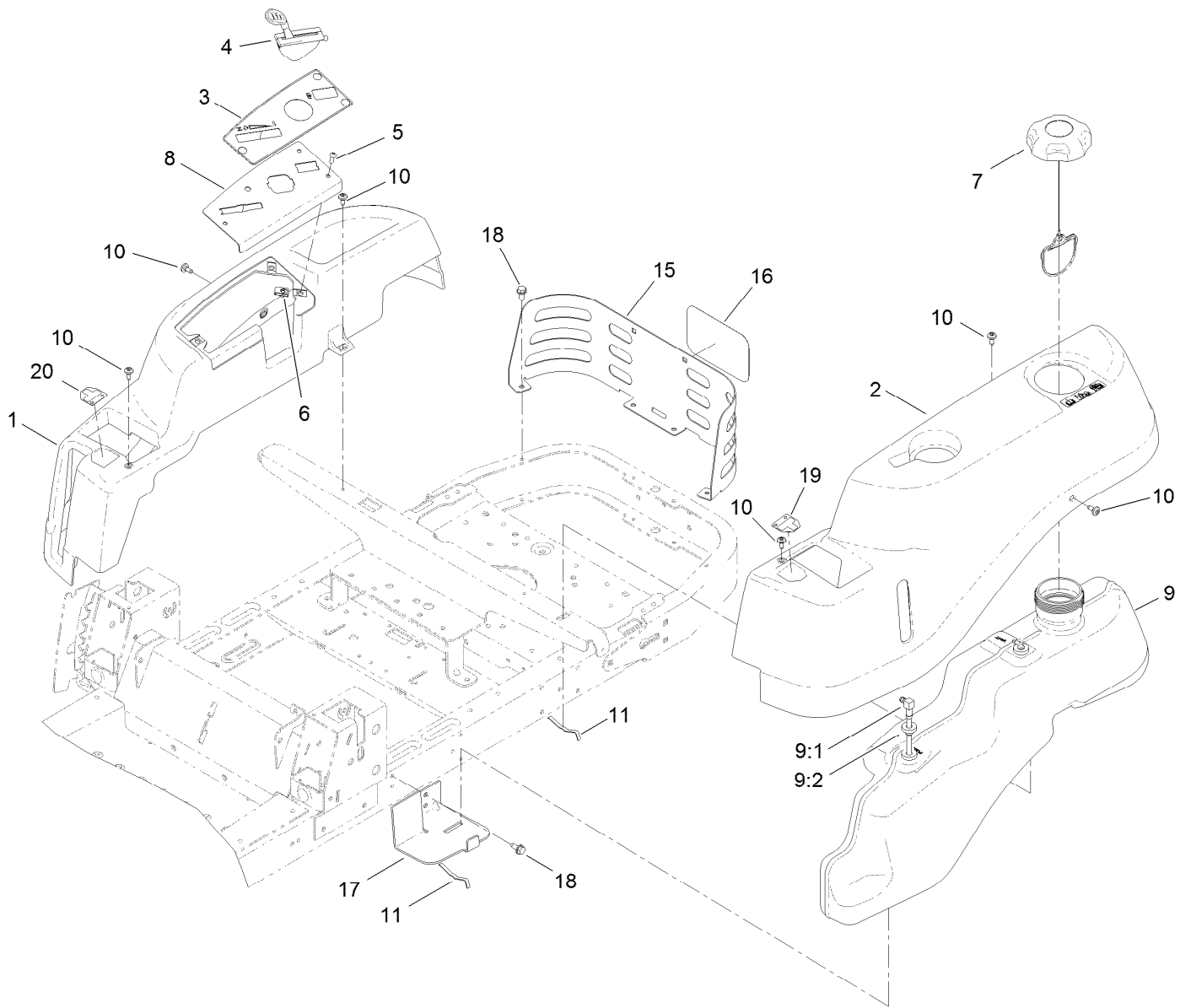

Body Styling and Fuel Pod Assembly

Ref.	Part Number	Qty.	Description
1	119-3335	1	Pod-RH
2	119-3334	1	Pod-LH
3	121-0771	1	Decal-Panel, Control
4	121-5673	1	Cable-Throttle And Choke
5	3258-166	3	Screw-PRH
6	107069	3	Clip
7	120-5461	1	Cap-Fuel, Ratcheting
8	119-3378-03	1	Plate-Control
9	119-3324	1	Fuel Tank ASM
9:1	121-0793	1	Connector-Elbow, 90 DEG

Ref.	Part Number	Qty.	Description
9:2	46-6560	2	Bushing
10	120-7950	6	Screw-Shoulder
11	609830	2	Spring
15	119-8855-03	1	Guard-Rear
16	105-8278	1	Decal
17	119-3476-03	1	Support-Tank, Front
18	32144-70	6	Screw-HWHTF
19	119-8814	1	Decal-Control Lever, LH
20	119-8815	1	Decal-Control Lever, RH

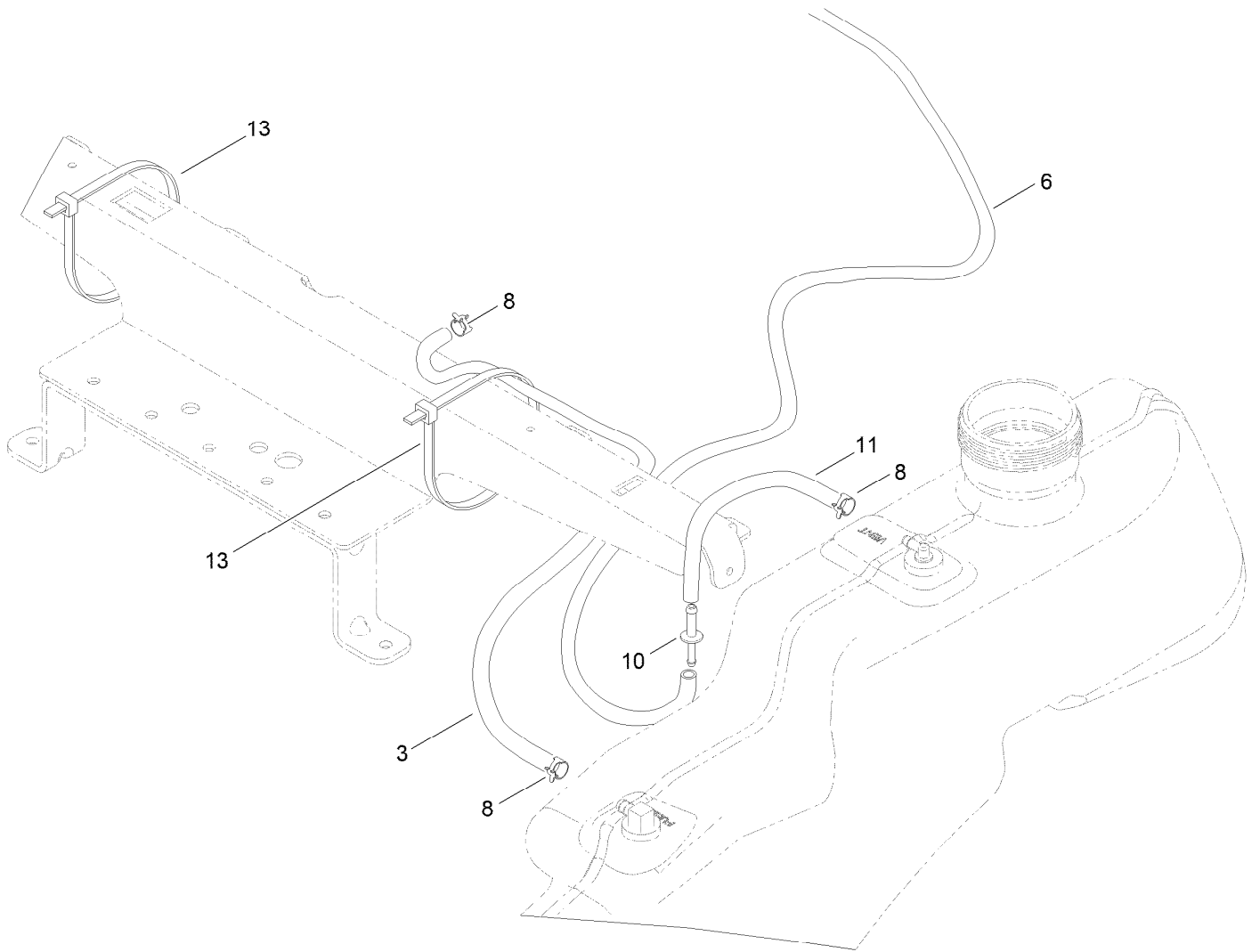

Fuel Delivery Assembly

<i>Ref.</i>	<i>Part Number</i>	<i>Qty.</i>	<i>Description</i>
3	110-5702	1	Hose-Fuel
6	121-0780	1	Hose-Fuel
8	2412-98	3	Clamp-Hose
10	117-5399	1	Adaptor-Orifice
11	110-1876	1	Hose-Fuel
13	3334-945	2	Tie-Cable

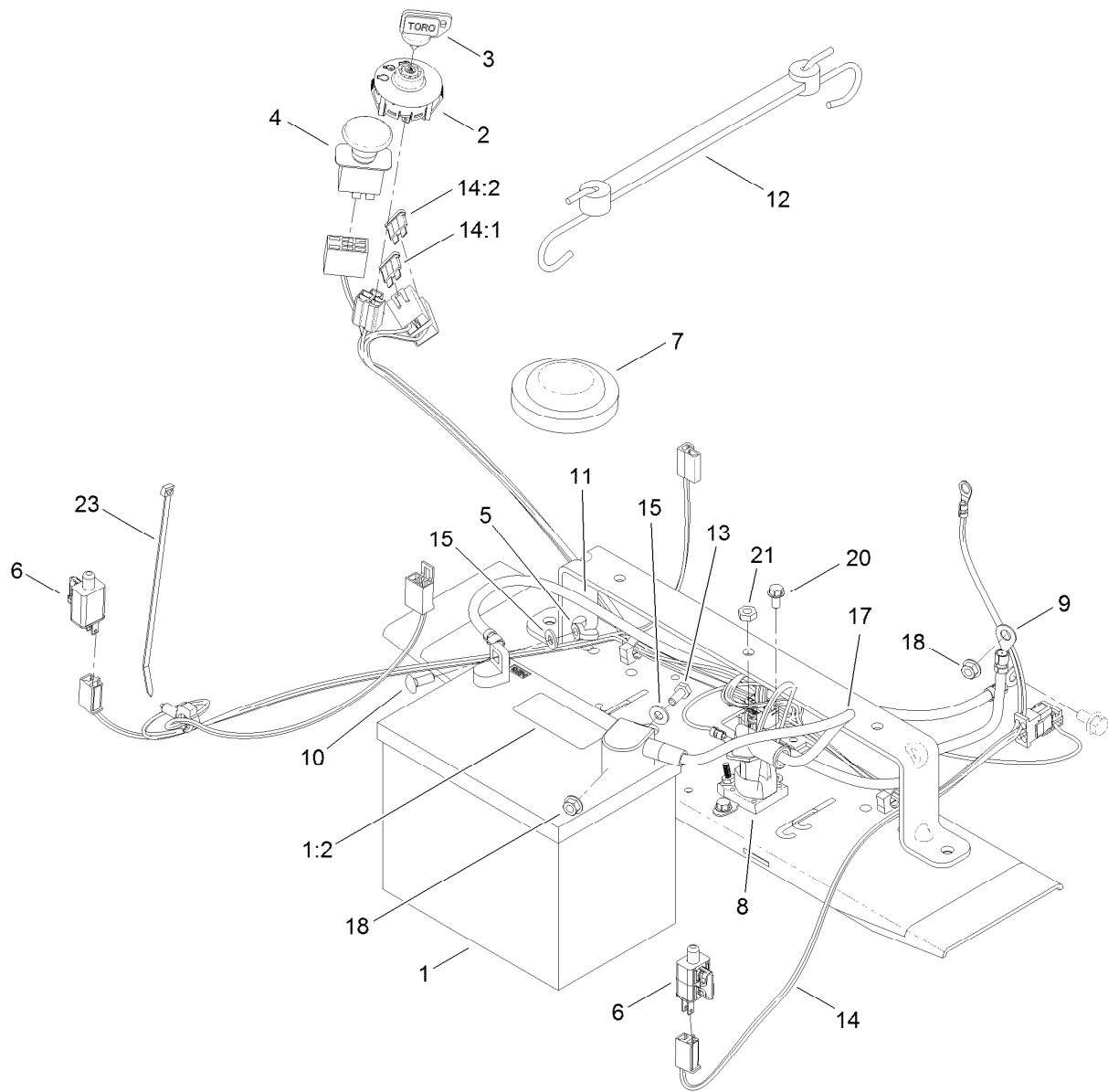

Electrical Assembly

<i>Ref.</i>	<i>Part Number</i>	<i>Qty.</i>	<i>Description</i>	<i>Ref.</i>	<i>Part Number</i>	<i>Qty.</i>	<i>Description</i>
1	105-1692	1	Battery	12	104-2466	1	Holddown-Battery
1:2	104-4164	1	Decal-Battery	13	321-3	1	Screw-HH
2	117-2221	1	Switch-Ignition	14	121-5652	1	Harness-Wire
3	63-8360	1	Key-Ignition	14:1	109103	1	Fuse-Blade, 30 Amp
4	103-5221	1	Switch-PTO	14:2	109102	1	Fuse-Blade, 25 Amp
5	32103-22	1	Nut-Wing	15	3256-22	2	Washer-Flat
6	110-6765	2	Switch-Single Pole No	17	119-8897	1	Cable-Battery, Red
7	100-3524	1	Switch-Seat	18	32128-33	2	Nut-HF
8	117-1197	1	Solenoid	20	32144-4	2	Screw-HWH
9	119-8898	1	Cable-Battery, Red	21	3220-2	2	Nut-Jam
10	3229-1	1	Screw-CARR	23	614249	1	Tie-Cable
11	119-8899	1	Cable-Battery, Black				

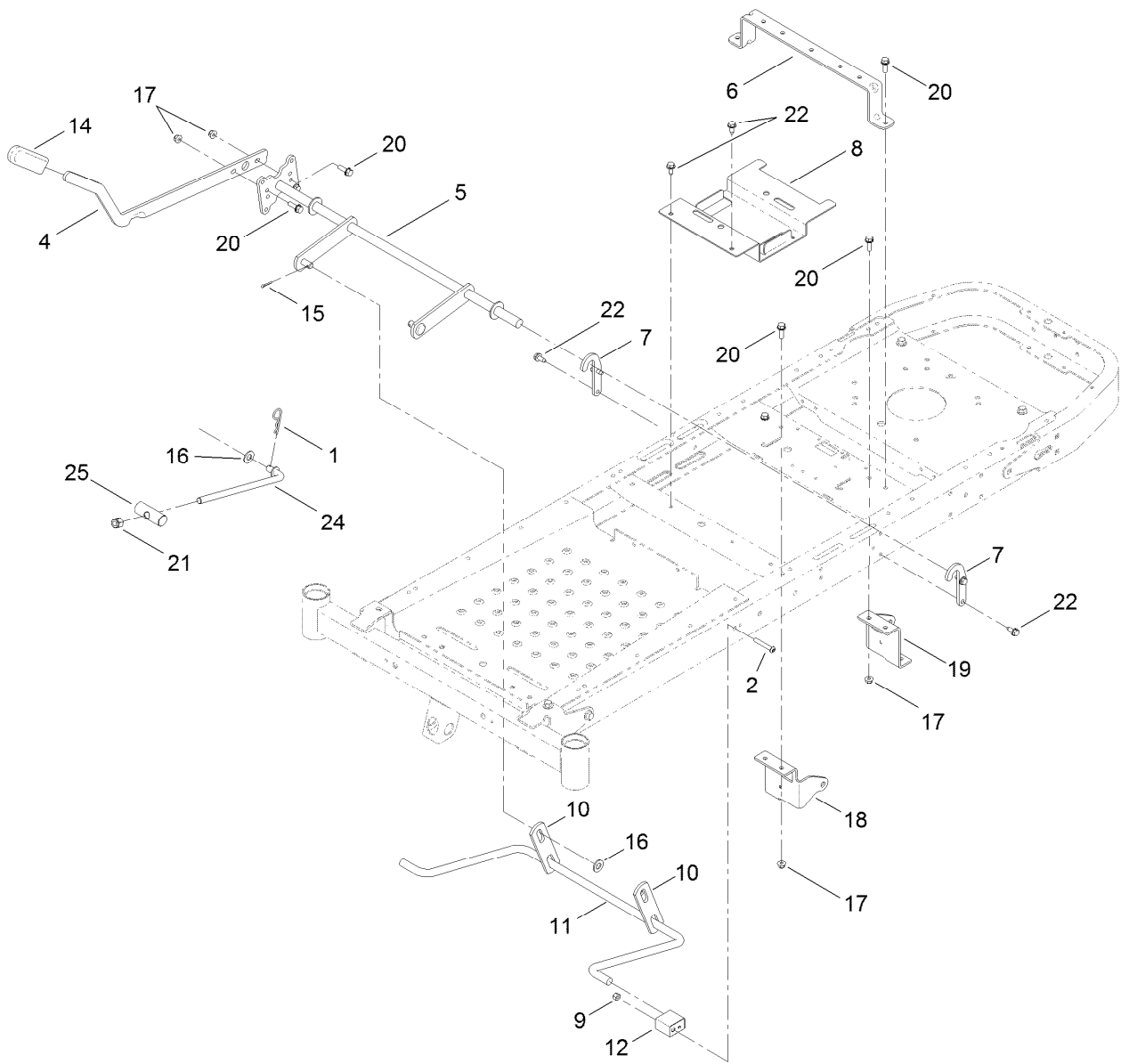

Deck Lift Assembly

<i>Ref.</i>	<i>Part Number</i>	<i>Qty.</i>	<i>Description</i>	<i>Ref.</i>	<i>Part Number</i>	<i>Qty.</i>	<i>Description</i>
1	1-806005	1	Pin-Hair	14	1-633268	1	Grip-Lever
2	120-5499	2	Screw-HSBH	15	3272-10	2	Pin-Cotter
4	119-3427-03	1	Lever-Lift	16	3256-26	3	Washer-Flat
5	117-7346-03	1	Deck Lift ASM	17	104-8300	6	Nut-Flange, NI
6	119-3435-03	1	Brace-Seat, Rear	18	119-8861-01	1	Mount-Hydro, Front RH
7	119-8875	2	Bracket-Lift	19	119-8862-01	1	Mount-Hydro, Front LH
8	119-3406-03	1	Bracket-Battery	20	3234-29	6	Screw-HHF
9	3296-29	2	Nut-Lock, NI	21	3296-19	1	Nut-Hex
10	108-7840	2	Link-Lift	22	32144-70	6	Screw-HWHTF
11	108-7839	1	Arm-Lift, Rear	24	104-8047	1	Rod-Trunion
12	108-7845	2	Block-Pivot	25	119-8810	1	Pin-Pivot

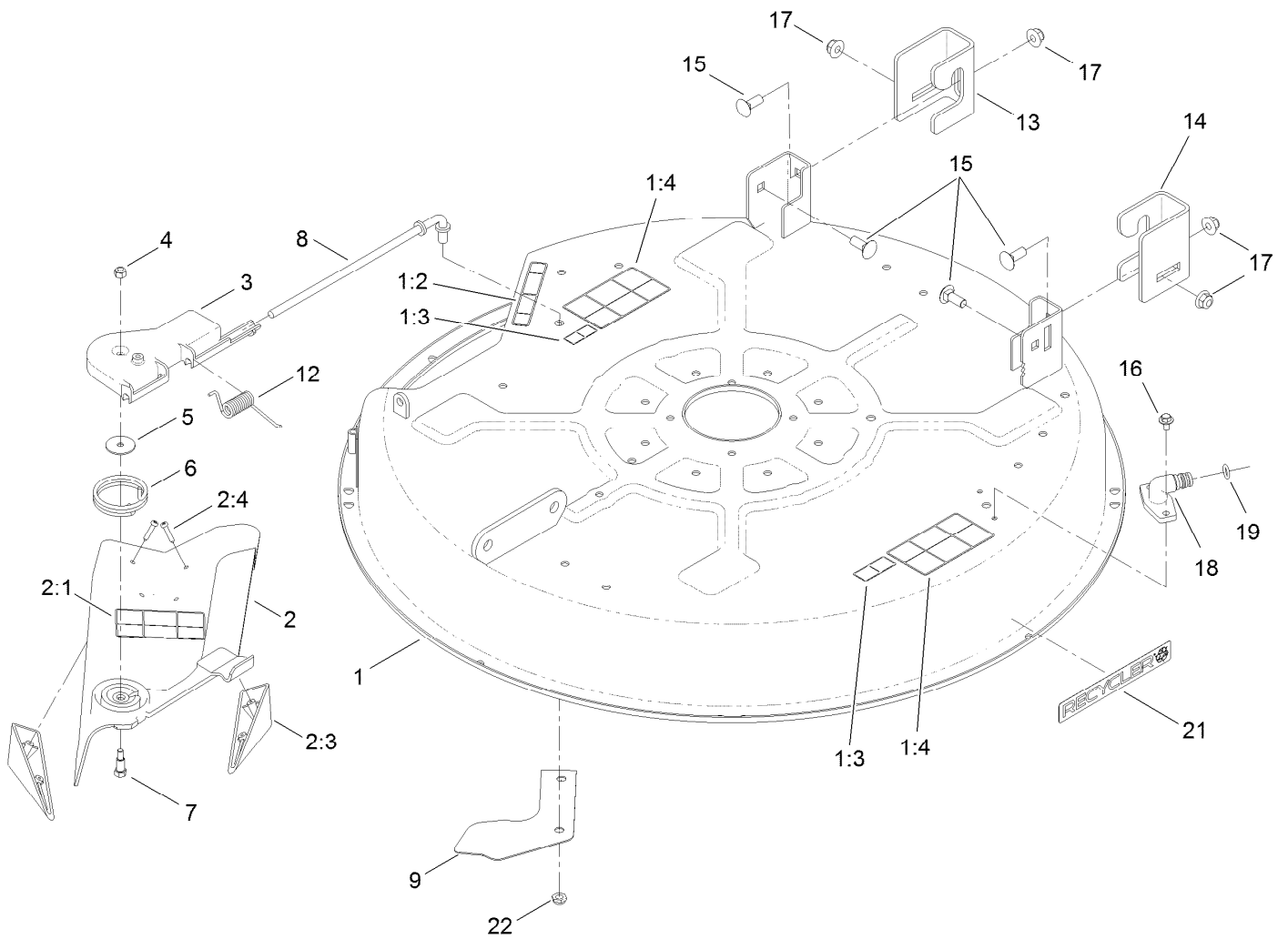

32 Inch Deck Assembly

Ref.	Part Number	Qty.	Description	Ref.	Part Number	Qty.	Description
1	119-8839	1	32 Inch Deck And Decal ASM	7	92-8916	1	Bolt-Shoulder
1:2	93-7009	1	Decal-Danger, Deflector	8	119-8858	1	Rod-Pivot
1:3	114-1606	2	Decal-Danger, Pulley	9	119-8877-03	1	Ramp-Deflector
1:4	110-6691	2	Decal-Danger	12	92-2493	1	Spring-Torsion
2	120-2298	1	32 Inch Deflector ASM	13	119-3494	1	Bracket-Hanger, RH
2:1	110-6691	1	Decal-Danger	14	119-3496	1	Bracket-Hanger, LH
2:3	93-7696	2	Kicker	15	3231-2	4	Screw-CARR
2:4	93-0231	4	Screw-PPH	16	46-8560	2	Screw-HHFTF
3	88-4540	1	Pivot-Hinge, Deflector	17	104-8301	4	Nut-Flange, NI
4	3296-42	1	Nut-Lock, NI	18	95-2747	1	Fitting-Washout
5	3256-58	1	Washer-Flat	19	46-6290	1	O-Ring, Seal
6	88-6160	1	Spring-Torsion	21	119-2368	1	Decal-Recycler
				22	3296-59	1	Nut-Lock, NI

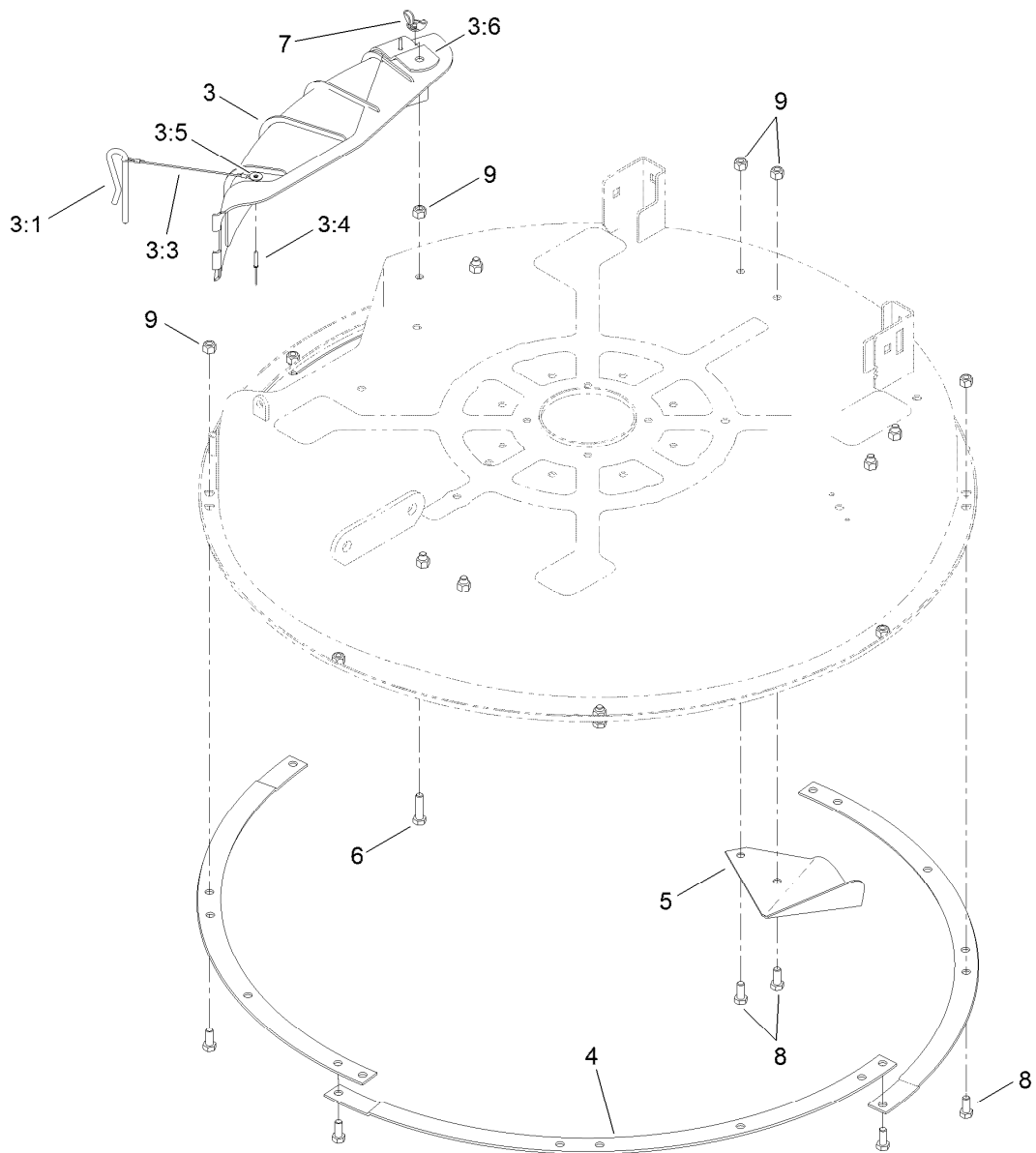

32 Inch Deck Baffle Assembly

Ref.	Part Number	Qty.	Description
3	82-6151	1	Discharge Cover ASM
3:1	28-8130	1	Pin-Locking, Chute
3:3	28-8070	1	Lanyard
3:4	3290-282	2	Rivet-Blind
3:5	3256-49	1	Washer-Flat
3:6	83-7010-03	1	Brace
4	80-4490-03	4	Ring-Deck
5	80-2630-03	4	Kicker
6	322-6	1	Screw-HH
7	32103-2	1	Nut-Wing
8	322-3	15	Screw-HH
9	3296-29	16	Nut-Lock, NI

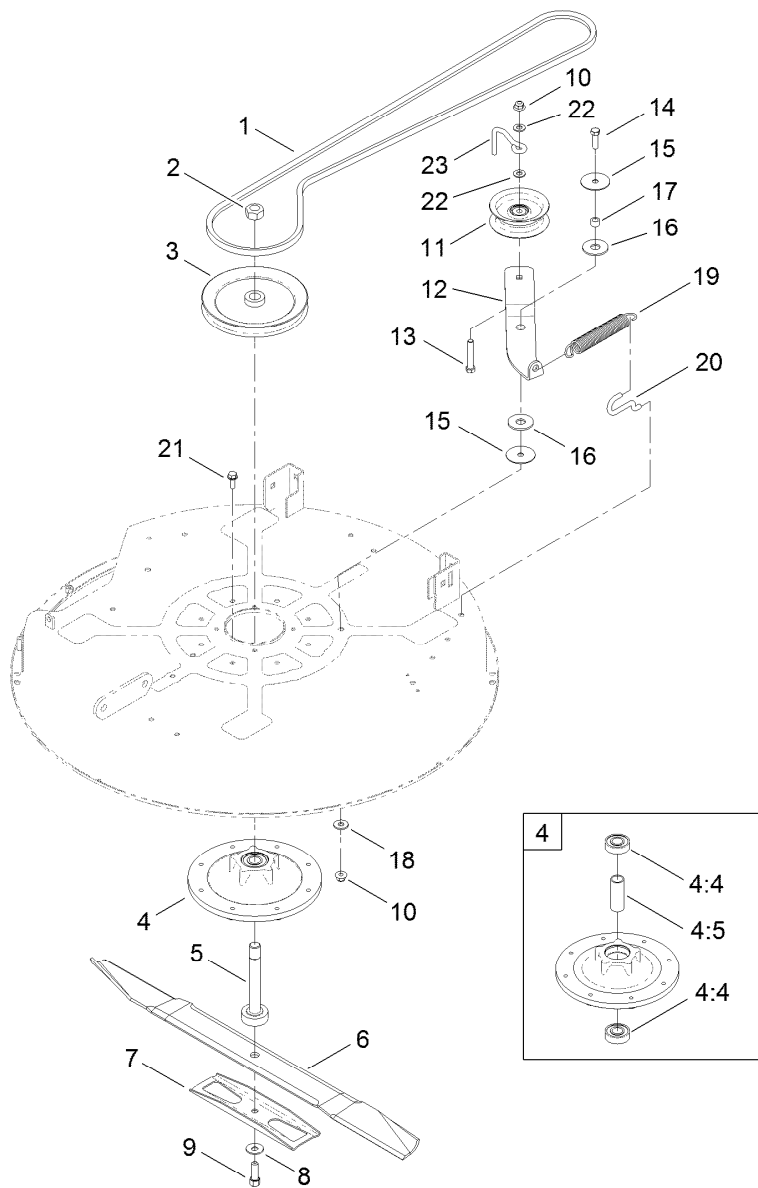

32 Inch Deck, Belt and Blade Assembly

<i>Ref.</i>	<i>Part Number</i>	<i>Qty.</i>	<i>Description</i>	<i>Ref.</i>	<i>Part Number</i>	<i>Qty.</i>	<i>Description</i>
1	119-8821	1	V-Belt, 81.8 Inch	12	119-8966	1	Arm-Idler
2	3219-7	1	Nut-Hex	13	323-11	1	Screw-HH
3	119-8804	1	Pulley-Deck	14	323-7	1	Screw-HH
4	119-0368	1	Spindle Housing ASM	15	120-2229	2	Washer-Idler Pivot
4:4	251-297	2	Bearing-Ball	16	114-0463	2	Washer-Friction, Composite
4:5	83-7020	1	Spacer-Bearing	17	115-4986	1	Spacer
5	119-8825	1	Shaft-Spindle	18	80-6990	1	Washer-Hardened
6	80-4430-03	1	Blade-Recycler, 31.35 Inch	19	106-2177	1	Spring-Extension
7	80-4570-03	1	Stiffener	20	88-5970	1	Hook-Return, Spring
8	3290-465	1	Washer-Belleville	21	32144-41	8	Screw-Taptite
9	26-0671	1	Screw-HH	22	3256-24	2	Washer-Flat
10	104-8301	2	Nut-Flange, NI	23	107-7307	1	Guide-Idler, Belt
11	106-2175	1	Pulley-Idler, Flat				

Attachments and Accessories

For 74385 TimeCutter ZS 3200 Riding Mower

Product Name	Model/Part
Hourmeter Kit, 2011 and After TimeCutter Riding Mower	120-5498
Belt Guard Kit	120-7770
Storage Cover (Waterproof, vented and abrasion/tear resistant)	490-7516
Foot Assist Deck Lift Kit, 2011 and After Zero-Turn-Radius Riding Mower	79010
Sunshade Kit, 2011 and After Zero-Turn-Radius Riding Mower	79011
Hitch Kit	79014
Floor Mat Kit, 2011 and After Zero-Turn-Radius Riding Mower w/ 32in or 42in Cutting Unit	79020
32in Bagger, 2011 and After TimeCutter 3000 Series Riding Mower	79333
10 cu. ft. Poly Dump Cart	79991

Notes:

Notes:



Count on it.