

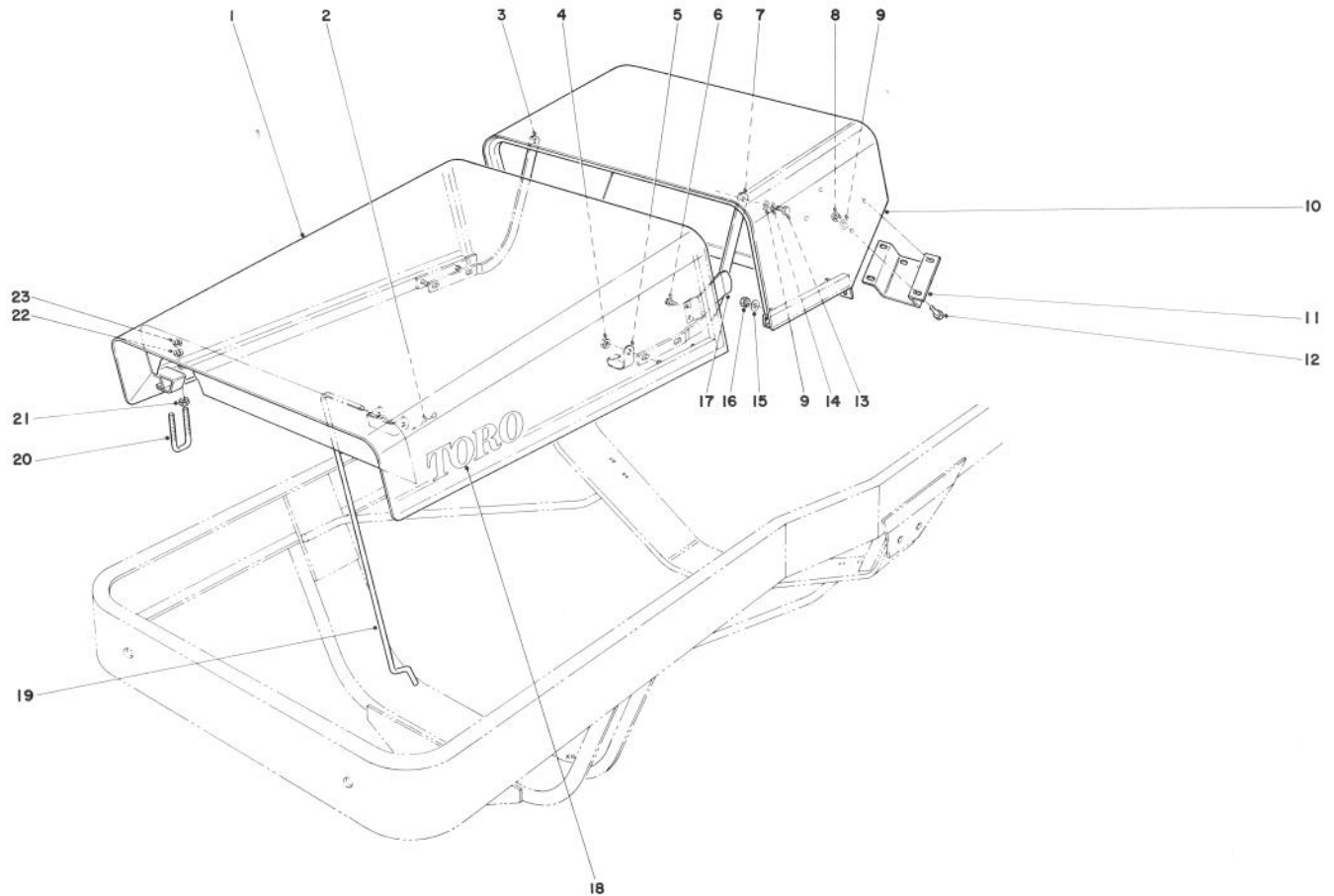

MODEL NO. 33787 — 80001 &amp; UP

**PARTS  
CATALOG**
**PARKMASTER 7 (Gasoline)**

**HOOD ASSEMBLY**

Ref. No.	Part No.	Description	No. Used
1	18-0630	Hood	1
2	3272-9	Cotter Pin	1
3	18-0760	Pivot Arm R.H.	1
4	32128-29	Lock Nut	4
5	18-1270	Hood Clip	1
6	32140-32	Screw	4
7	18-0750	Pivot Arm L.H.	1
8	32153-3	Lock Nut	4
9	3256-23	Flatwasher	6
10	18-0560	Cowl	1
11	18-0770	Steering Column Support	1
12	322-2	Capscrew	4

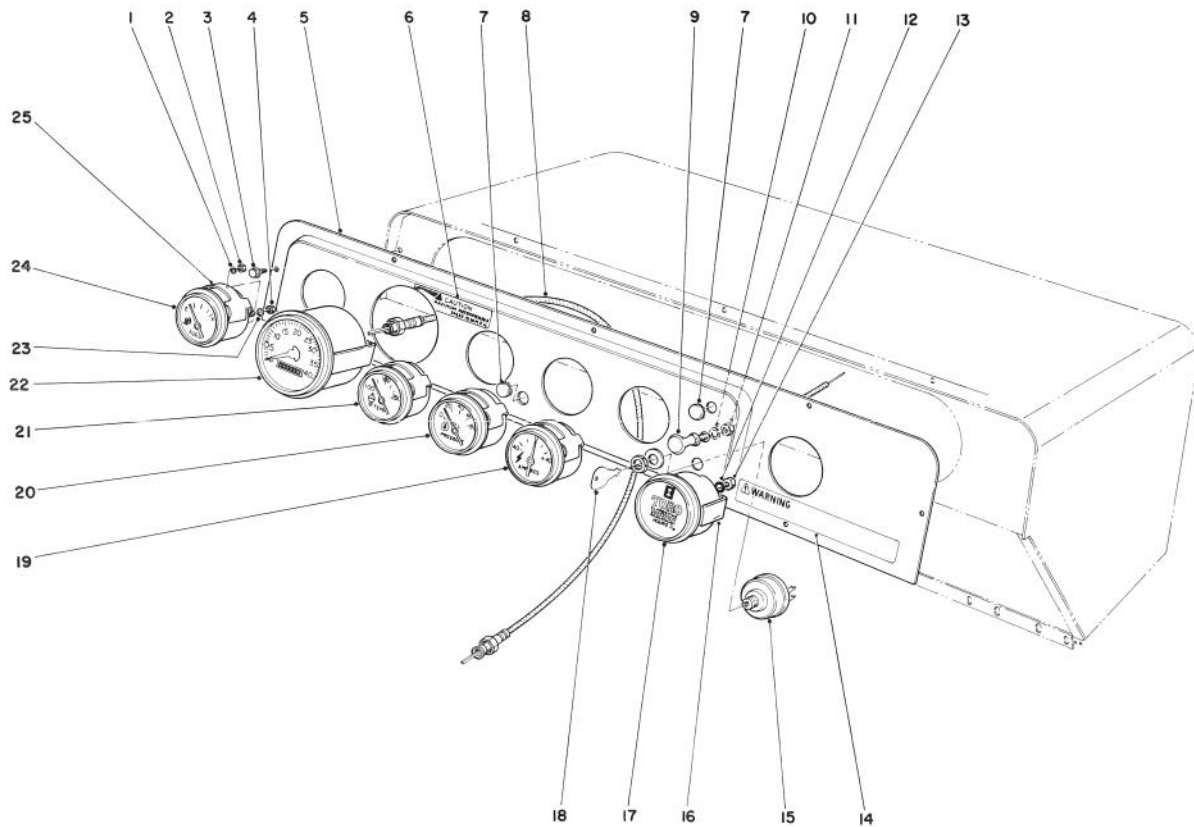
Ref. No.	Part No.	Description	No. Used
13	322-1	Capscrew	2
14	3253-4	Lockwasher	2
15	3256-24	Flatwasher	4
16	32153-2	Lock Nut	4
17	18-3230	Hood Support Spring	2
18	18-2180	Decal — Hood	2
19	18-1280	Hood Prop	1
20	18-1290	U-Bolt	2
21	3218-1	Jam Nut	4
22	3253-3	Lockwasher	4
23	3217-5	Nut	4



## DASH ASSEMBLY

Ref. No.	Part No.	Description	No. Used
1	3254-9	Lockwasher	8
2	3217-29	Nut	8
3	33104-76	Self-Tapping Screw	8
4	3219-14	Nut	8
5	18-1390	Instrument Panel	1
6	28-1030	Decal - Caution	1
7	2410-13	Plug Button	2
8	18-2670	Speedometer Cable	1
9	3-3196	Choke (Incl. Ref. #10 & 11)	1
10	3253-21	Lockwasher	1
11	3220-3	Jam Nut	1
12	3254-1	Washer - Lock	1
13	3217-26	Nut	1
14	39-3680	Decal - Warning	1

Ref. No.	Part No.	Description	No. Used
15	12-8140	Ignition Switch (Incl. Ref. #18)	1
16	218-515	Clamp - Hour Meter	1
17	12-9990	Hourmeter (Incl. Ref. #16)	1
18	218-412	Key (2)	1
19	38-1660	Ammeter (Incl. Ref. #25)	1
20	38-1630	Oil Pressure Gauge (Incl. Ref. #25)	1
21	38-1640	Temperature Gauge (Incl. Ref. #25)	1
22	18-2230	Speedometer	1
23	3253-17	Lockwasher	8
24	38-1650	Fuel Gauge (Incl. Ref. #25)	1
25		Mounting Bracket	4

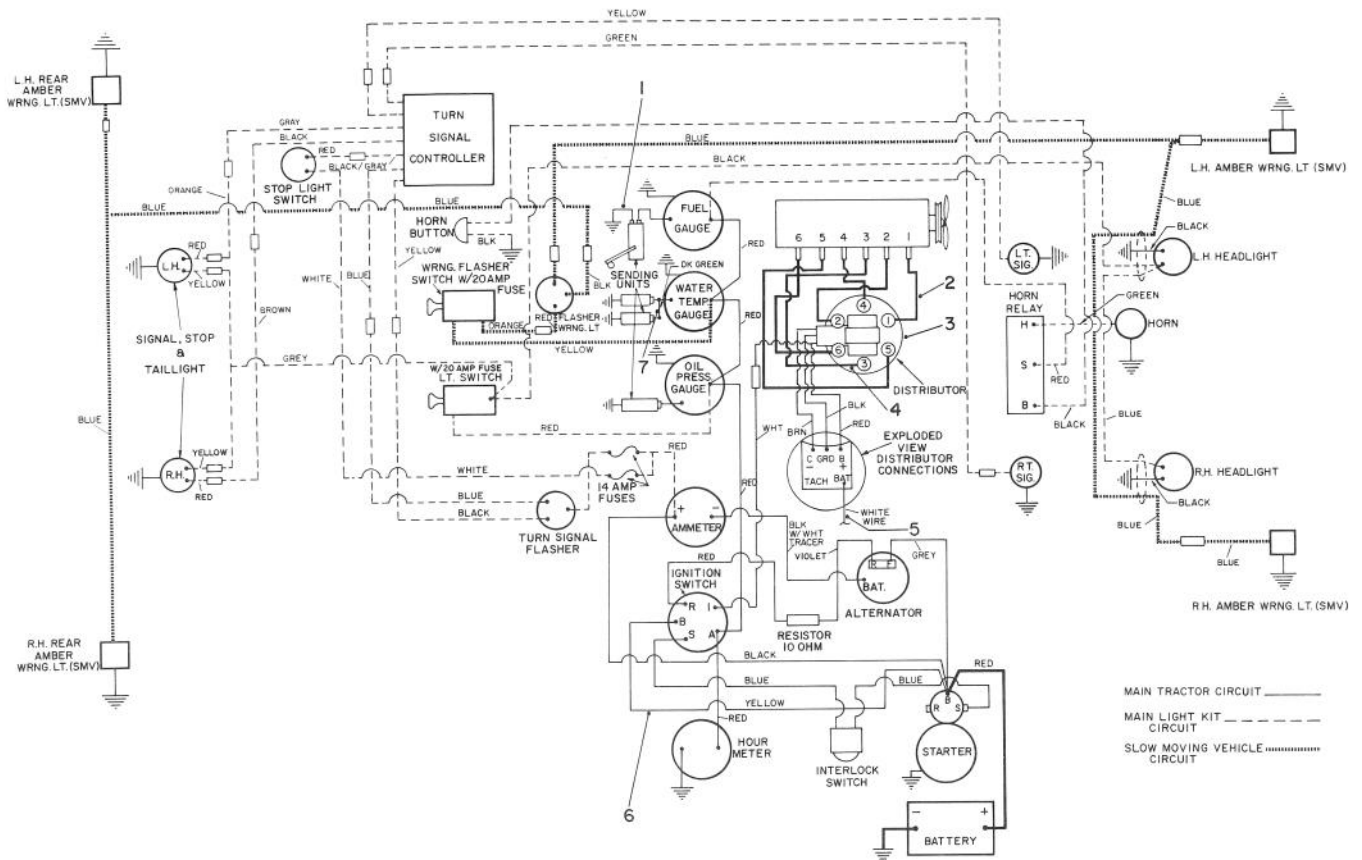

## WIRING HARNESS — 12 Volt Negative Ground

Ref. No.	Part No.	Description	No. Used
*1	3-3868	Ground Wire	1
*2	33-0670	Spark Plug Wire No. 1 & 2	2
**3	1103498	Distributor	1
*4	56-9600	Spark Plug Wire No. 3-6	1

Ref. No.	Part No.	Description	No. Used
*5	37-4530	Jumper Wire	1
*6	23-7990	Wiring Harness Complete	1
*7	39-7600	Jumper Wire (Temp. Sender to Thermo Switch)	1

\*Obtain from your Toro Distributor.

\*\*Obtain from your local GM, Chevrolet Dealer.

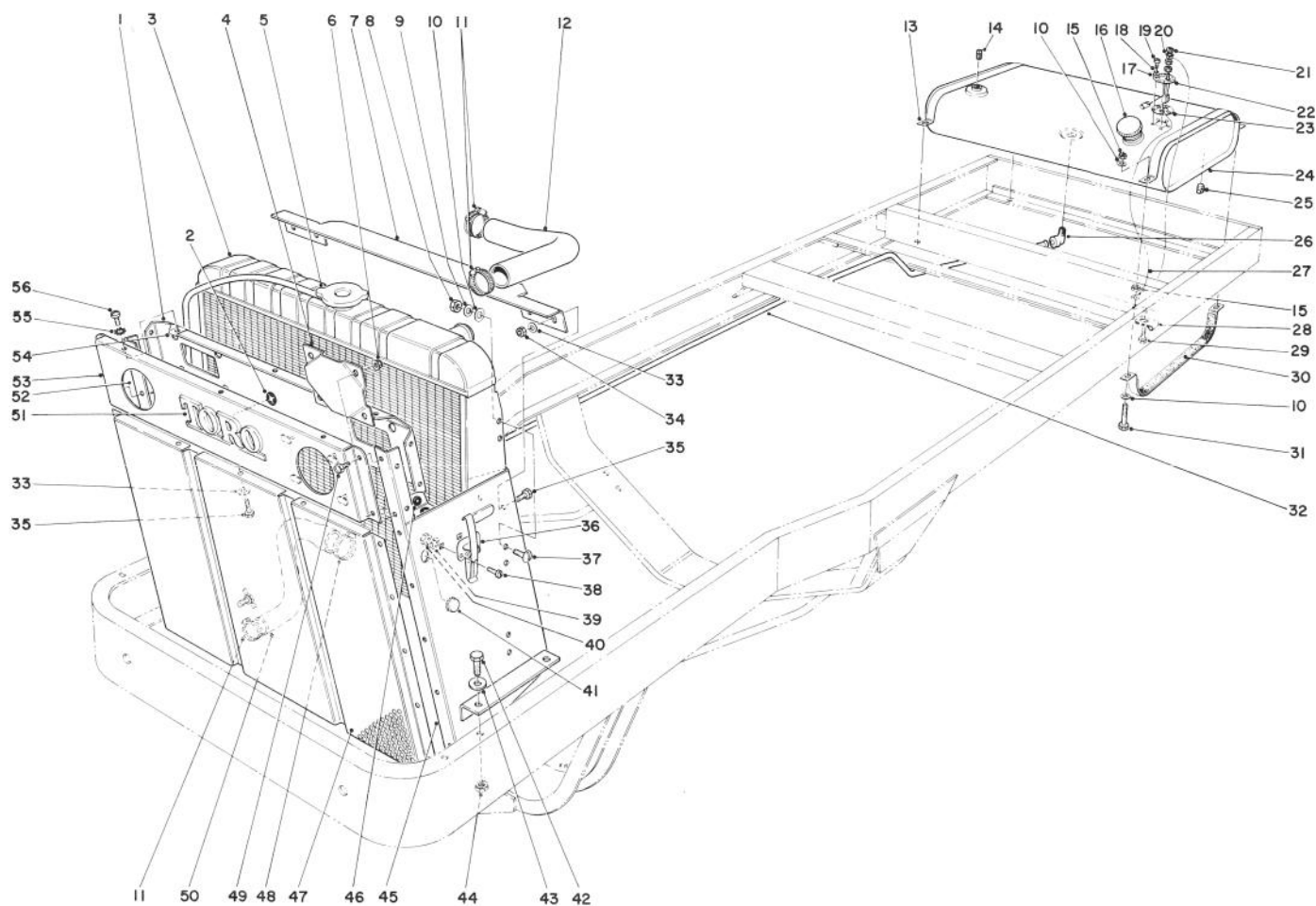

## RADIATOR AND FUEL TANK ASSEMBLY

Ref. No.	Part No.	Description	No. Used
1	18-1020	Cover — Headlights	1
2	3290-363	Tinnerman Clip	5
3	62-6970	Radiator	1
4	18-4350	Cover — Headlight Hole	2
5	18-2660	Radiator Cap	1
6	32128-17	Flange Nut	8
7	18-1030	Deflector — Fan	1
8	3217-6	Nut	8
9	3253-4	Lockwasher	8
10	3256-23	Washer — Plain	16
11	2412-3	Hose Clamp	3
12	18-1820	Radiator Hose Upper	1
13	36-8280	Strap — Fuel Tank	4
14	281-7	Pipe — Plug Square Head	1
15	32153-3	Nut — Lock	8
16	222-8	Filler Cap	1
17	237-49	Washer — Nylon	5
18	3254-1	Washer — Lock Internal Tooth	5
19	3252-16	Screw — Machine Fillister Hd.	5
20	3255-17	Washer — Lock	1
21	3219-14	Nut — Hex	1
22	18-2370	Sender — Fuel Level	1
23	18-2380	Gasket — Fuel Sending Unit	1
24	36-8290	Fuel Tank (Incl. Ref. #16)	1
25	281-5	Pipe Plug	1
26	353-420	Fitting	1
27	3-3868	Wire — Ground	1
28	18-2970	Clip — Fuel Line	1

Ref. No.	Part No.	Description	No. Used
29	32104-32	Screw — Tapping Hex Hd.	1
30	3-3824	Felt Strip — Fuel Tank	4
31	3290-319	Screw — Machine Hex Hd.	4
32	44-2630	Fuel Line	1
33	3256-22	Washer	7
34	32153-4	Nut — Lock	4
35	321-2	Capscrew	7
36	249-10	Hood Clamp	2
37	32122-14	Machine Screw	8
38	3252-2	Screw — Fillister Hd.	4
39	3253-17	Lockwasher	4
40	3217-26	Nut	4
41	2410-13	Plug Button	2
42	325-20	Screw — Cap Hex Hd.	4
43	3256-26	Washer — Plain	4
44	32153-5	Nut — Lock	4
45	18-0880	Front Side Panel L.H.	1
46	237-37	Rubber Bumper	4
47	18-0960	Grille	1
48	2412-42	Clamp Hose	1
49	32140-42	Screw — Self Tapping	14
50	18-1830	Radiator Hose — Lower	1
51	25-9650	Toro Emblem	1
52	18-0870	Front Side Panel R.H.	1
53	37-2230	Headlight Panel	1
54	3290-192	Tinnerman Clip	7
55	3255-7	Washer — Lock External Tooth	7
56	3290-145	Screw — Pan Hd.	7

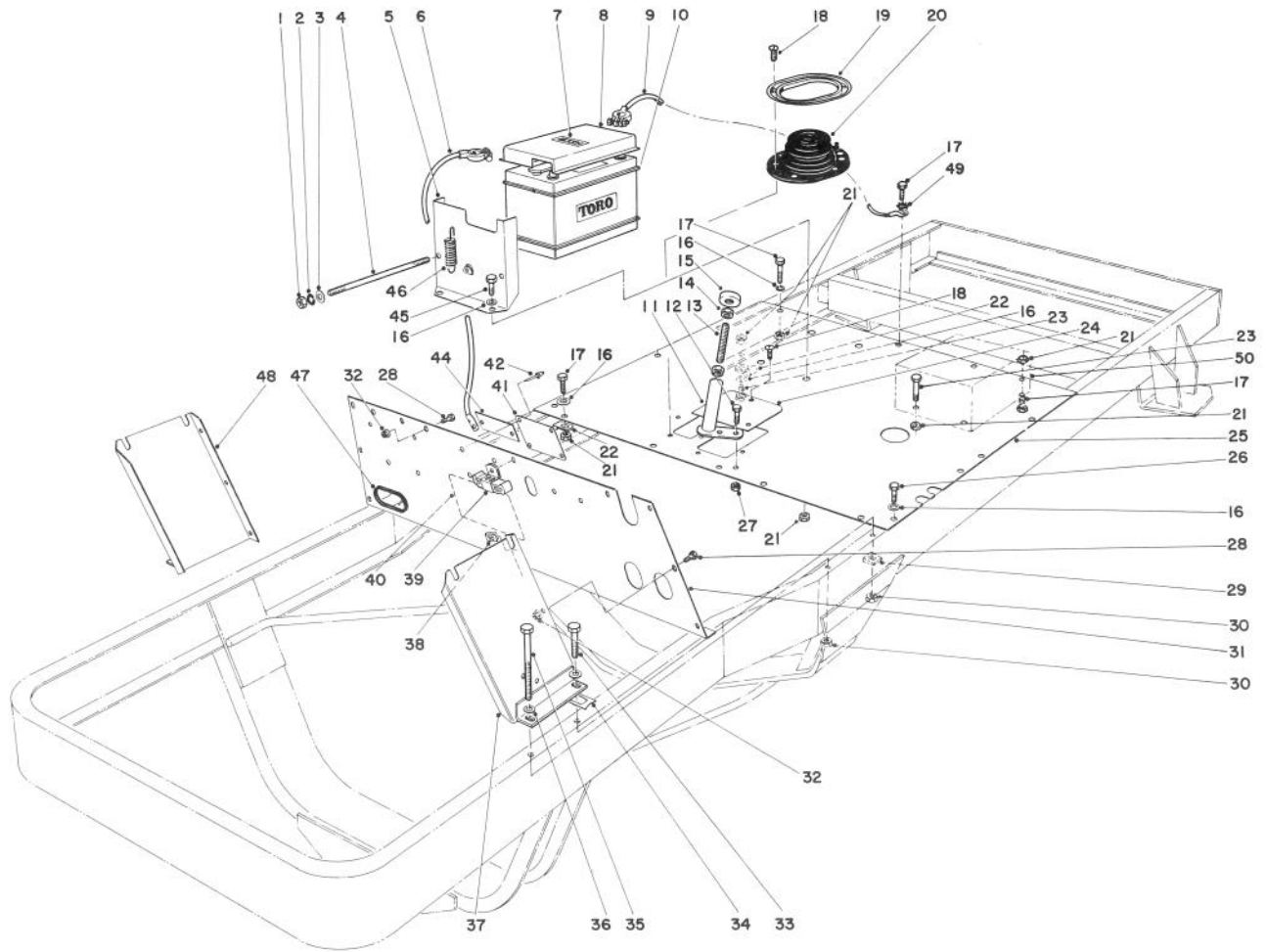

## TOE BOARD AND BATTERY ASSEMBLY

Ref. No.	Part No.	Description	No. Used
1	3217-5	Nut — Hex	4
2	3253-3	Washer — Lock Spring	4
3	3256-2	Washer — Plain	4
4	5-0678	Rod — Battery	2
5	3-5967	Support Battery	2
6	44-2150	Cable — Battery (Positive)	1
7	3-5582	Decal (No Step)	1
8	3-3175	Cover — Battery	1
9	218-208	Cable — Ground	1
10	55-7290	Battery	1
11	10-3150	Foot Rest	1
12	322-3	Capscrew	2
13	5-2973	Rod	1
14	3219-2	Nut — Hex Jam	2
15	5-2967	Button	1
16	3256-24	Washer Plain	18
17	323-5	Screw — Cap Hex. Hd.	8
18	32104-76	Screw—Self Tapping Acorn Hd.	9
19	36-9380	Retainer — Boot	1
20†	378340	Boot Transmission	1
21	32153-2	Nut — Lock	14
22	18-2970	Clamp	2
23	323-7	Capscrew	3
24	44-2080	Plate — Shift Closure	1
25	44-1120	Floor Plate	1

Ref. No.	Part No.	Description	No. Used
26	11-0590	Screw — Self Tapping Hex. Hd.	6
27	32153-3	Nut — Lock	2
28	3290-321	Capscrew	9
29	3290-216	Washer — Bevel	3
30	32153-5	Nut — Lock	4
31	18-0850	Toe Board	1
32	32128-17	Locknut — Flange	9
33	325-9	Screw — Cap Hex Hd.	3
34	20-5040	Shim	A/R
35	325-23	Screw — Cap Hex. Hd.	1
36	3256-26	Washer — Plain	4
37	18-0790	Rear Side Plate L.H.	1
38	218-214	Tinnerman Clip	1
39	18-2680	Resistor — 10 Ohm	1
40	38-1690	Starting Instructions	1
41	18-3200	Instruction Plate	1
42	3290-56	Pop — Rivet	6
44	18-2170	Name Plate	1
45	323-6	Screw — Cap Hex. Hd.	4
46	3-8135	Spring	2
47	18-2310	Grommet	1
48	18-0800	Rear Side Plate R.H.	1
49	3255-9	Lockwasher External Tooth	1
50‡		Seat Base	1

†Obtain from your local GM, Chevrolet Dealer.

‡See Page 42 for ordering parts.

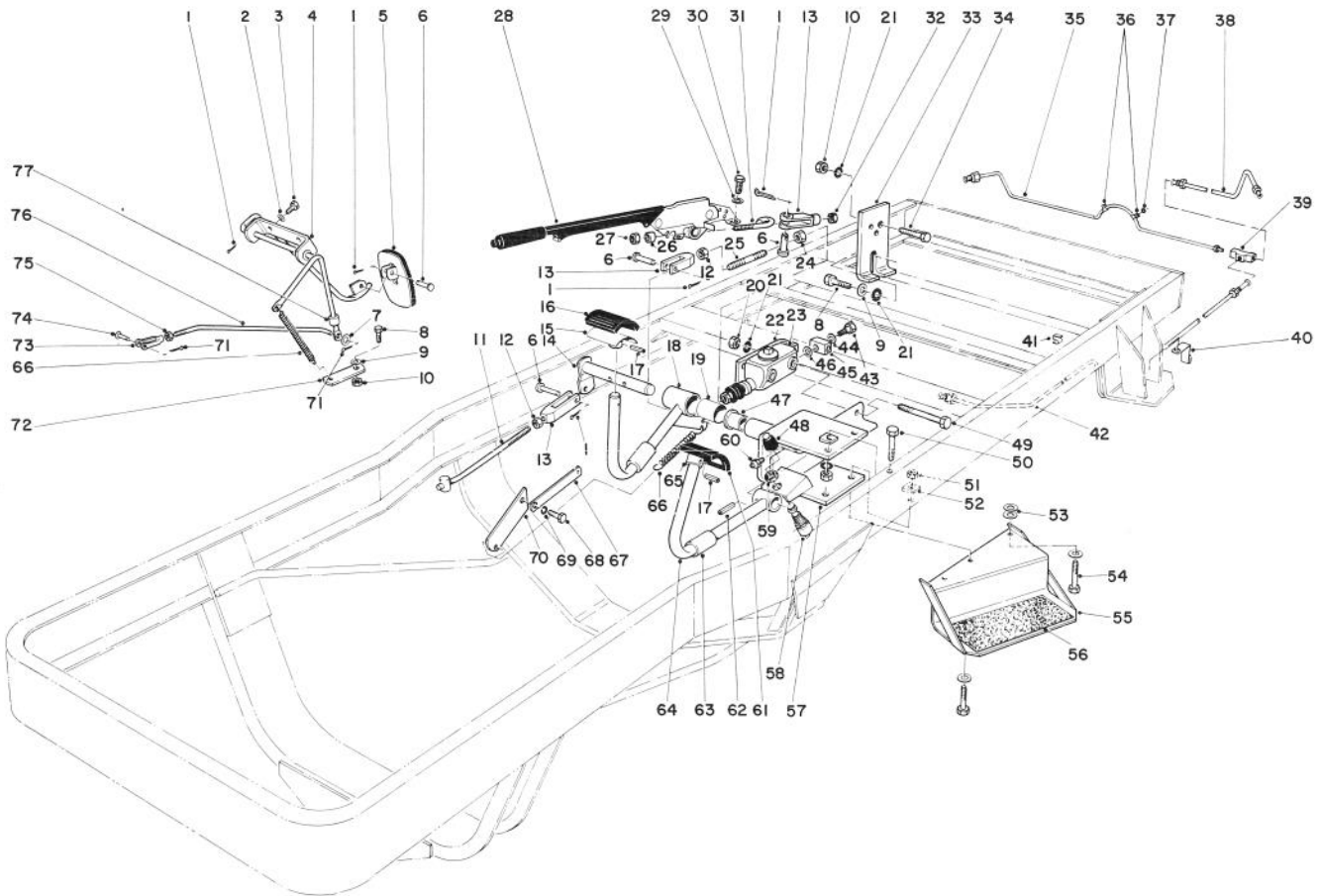

## BRAKE, CLUTCH, THROTTLE CONTROLS

Ref. No.	Part No.	Description	No. Used
1	3272-6	Cotter Pin	6
2	3253-4	Lockwasher	2
3	32104-32	Capscrew – Self Tapping	2
4	18-2510	Arm – Foot Throttle	1
5	10-2670	Accelerator Pedal	1
6	283-2	Pin	4
7	3256-22	Washer – Plain	1
8	323-5	Capscrew	2
9	3256-24	Washer	2
10	32153-2	Nut – Lock	2
11	18-1320	Clutch Link	1
12	3220-3	Nut – Jam	2
13	282-1	Clevis	3
14	18-1160	Pedal Shaft	1
15	10-0670	Brake Pedal	1
16	7-3900	Brake Pad	1
17	32121-34	Pin – Roll	2
18	3-8760	Brake Pedal (Incl. Ref. #19)	1
19	256-143	Bushing	1
20	3217-7	Nut – Hex	2
21	3253-21	Washer – Lock	4
22	42-3690	Shield Brake Fitting	1
23	37-4180	Master Cylinder	1

Ref. No.	Part No.	Description	No. Used
24	3218-3	Jam Nut	1
25	37-2060	Shaft – Brake Cylinder	1
26	29-4750	Spacer	1
27	3296-29	Nut – Lock	1
28	37-2740	Parking Brake Assembly	1
29	3256-23	Washer – Plain	2
30	322-5	Screw – Cap Hex. Hd.	2
31	44-2050	Rod – Parking Brake	1
32	3219-3	Nut – Hex	1
33	44-2040	Bracket Cable Support	1
34	323-7	Screw – Cap Hex. Hd.	1
35	37-3340	Brake Tube	1
36	3-3075	Clip	2
37	3254-6	Washer – Internal Tooth	2
38	37-3330	Brake Tube	1
39	304-2	Fitting Tee	1
40	46-6460	Support – Brake Line	2
41	212-93	Clip – Wire	3
42	42-3700	Brake Tube	1
43	42-3720	Connecting Bolt	1
44	42-3730	Inlet Connecting Gasket	1
45	42-3710	Fitting	1
46	353-689	Sealing Washer	1

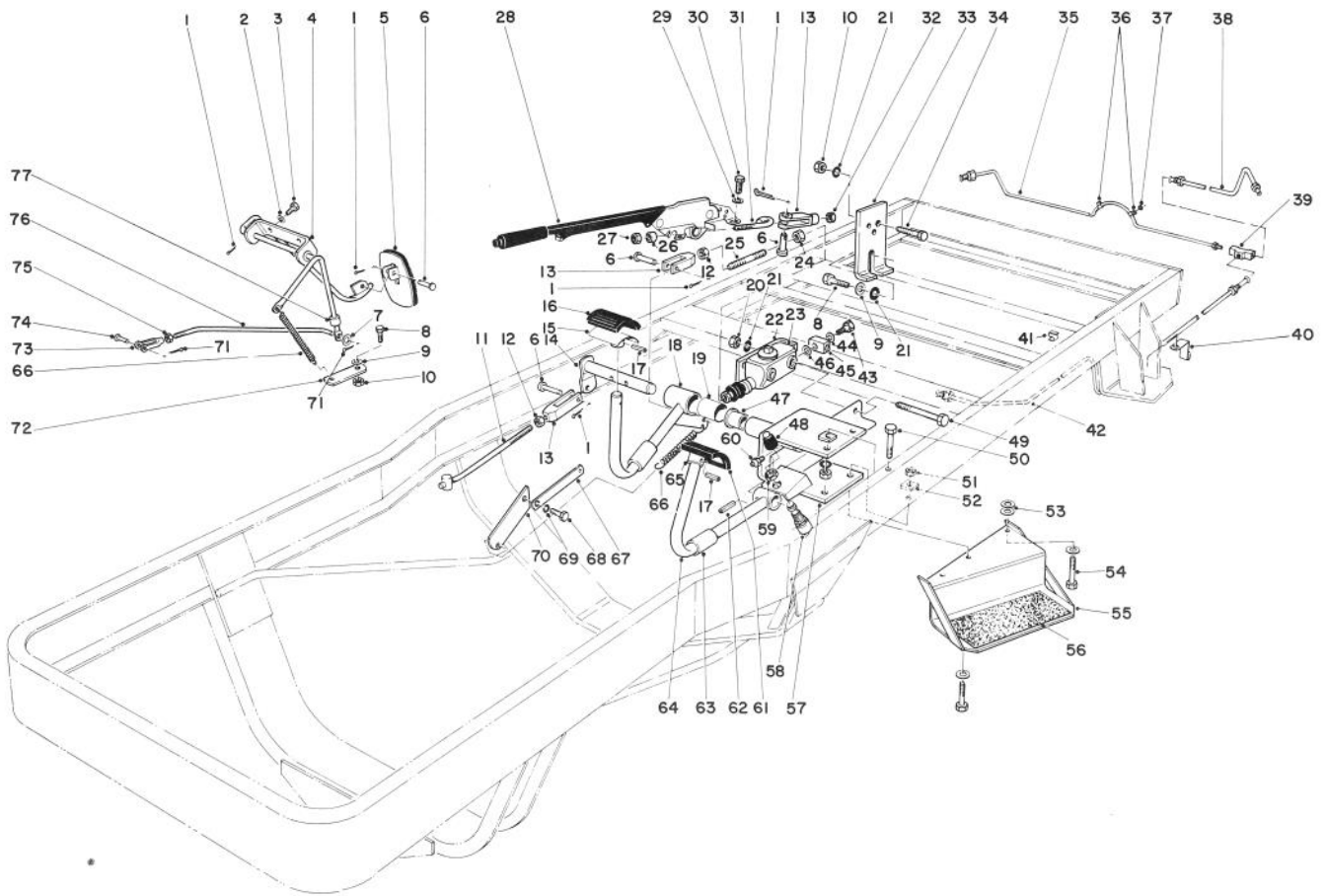

## BRAKE, CLUTCH, THROTTLE CONTROLS (Continued)

Ref. No.	Part No.	Description	No. Used
47	256-10	Bushing	2
48	39-0770	Rubber Boot	1
49	323-20	Capscrew – Hex Hd.	2
50	325-6	Capscrew	2
51	32153-5	Nut – Lock	5
52	3290-216	Washer – Bevel	5
53	3256-26	Washer – Plain	5
54	325-7	Screw – Cap Hex Hd.	3
55	33-2190	Foot Step	1
56	33-2230	Pad – Step	1
57	37-3120	Pedal Shaft Bracket (Incl. Ref. #47)	1
58	23-8010	Interlock Switch (Incl. Ref. #48 & 59)	1
59	218-461	Nut	2
60	302-5	Grease Fitting	1
61	7-3901	Clutch Pad	1

Ref. No.	Part No.	Description	No. Used
62	32121-15	Roll Pin	1
63	3-3107	Bumper – Clutch Pedal	2
64	3-3750	Clutch Pedal	1
65	10-0680	Clutch Pedal	1
66	5-1706	Spring – Extension	2
67	18-1050	Bracket Brake Return Spring	1
68	325-3	Screw – Cap Hex Hd.	1
69	3253-7	Washer – Lock	1
70	18-1060	Bracket – Clutch Return Spring	1
71	3272-5	Cotter Pin	2
72	38-2090	Strap – Throttle Spring	1
73	282-17	Yoke	1
74	283-3	Pin Clevis	1
75	3220-1	Nut – Jam	1
76	18-2610	Link – Foot Throttle	1
77	18-2860	Rubber Bumper, Foot Throttle	1

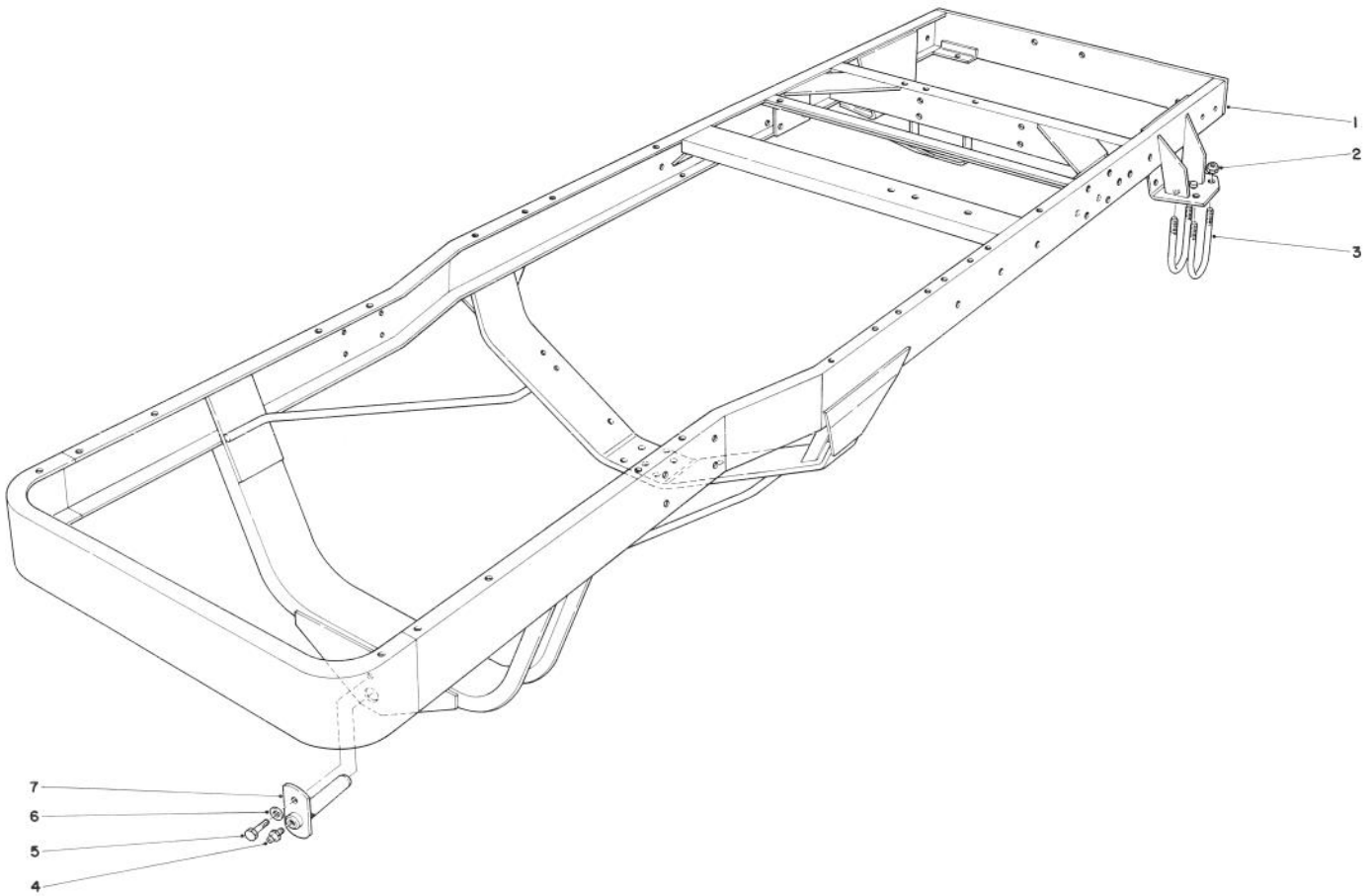

## FRAME ASSEMBLY

Ref. No.	Part No.	Description	No. Used
1	44-1230	Frame	1
2	3296-51	Locknut	8
3	46-6450	U-Bolt	4
4	302-2	Grease Fitting	1

Ref. No.	Part No.	Description	No. Used
5	32104-6	Screw	1
6	3256-24	Flat Washer	1
7	3-3760	Pivot Pin	1



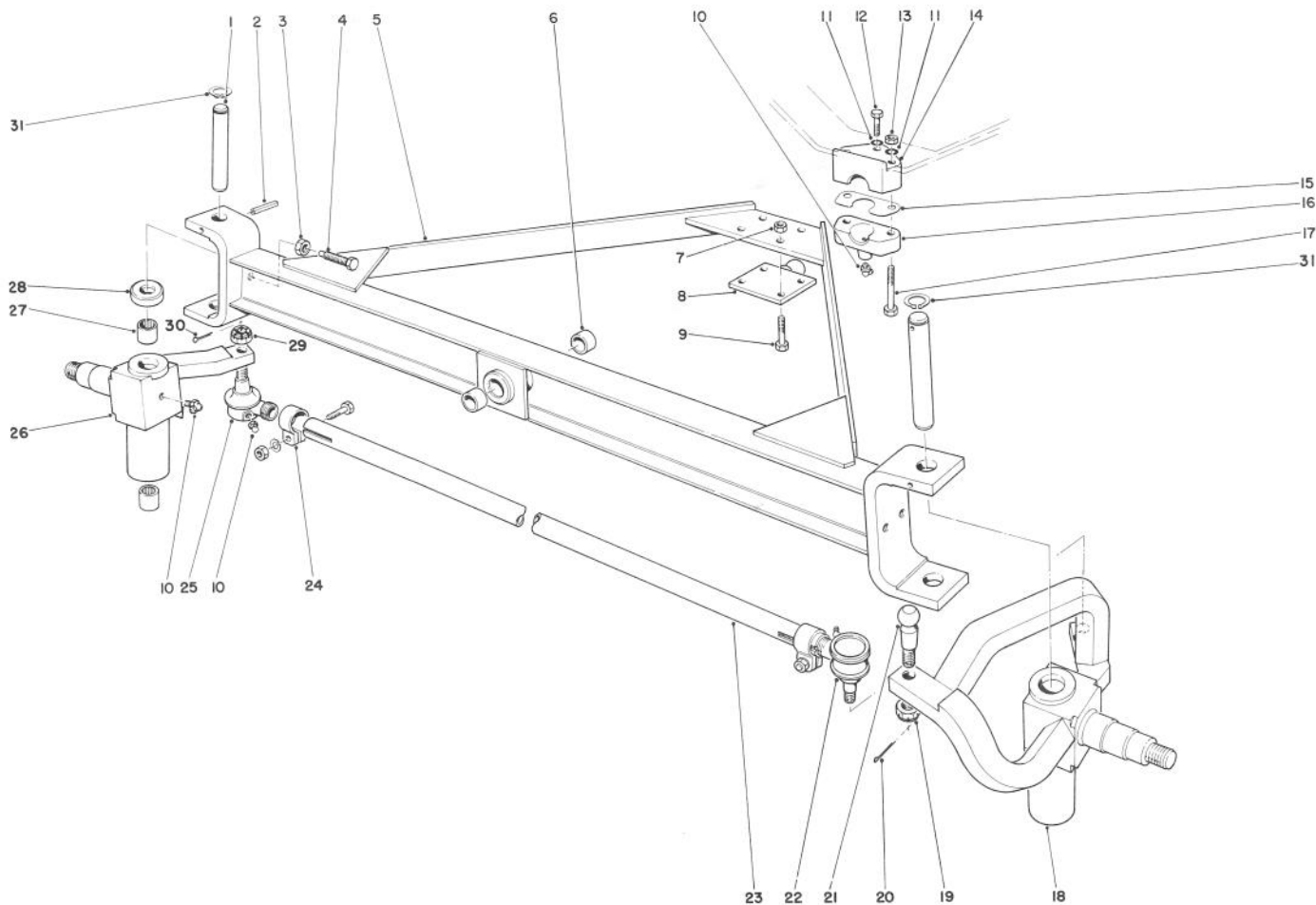

## FRONT AXLE ASSEMBLY

Ref. No.	Part No.	Description	No. Used
1	24-6900	Spindle Pin	2
2	32121-34	Roll Pin	4
3	3218-5	Jam Nut	3
4	32102-14	Set Screw	3
5	26-2320	Front Axle (Incl. Ref. #6)	1
6	256-126	Bushing	2
7	32153-5	Locknut	4
8	12-0360	Pivot Block	1
9	325-7	Capscrew	4
10	302-33	Grease Fitting	5
11	3253-8	Lockwasher	3
12	327-4	Capscrew	1
13	3219-6	Nut	2
14	3-2968	Lower Ball Socket	1
15	3-3825	Shim	A/R
16	3-2967	Upper Ball Socket	1

Ref. No.	Part No.	Description	No. Used
17	3214-13	Capscrew	2
18	23-5300	Spindle L.H.	1
19	32136-3	Slotted Nut	1
20	3272-7	Cotter Pin	1
21	5-2966	Ball Stud	1
22	2116-3	Ball Joint L.H.	1
23	3-3710	Tie Rod Assembly (Incl. Ref. #10, 22, 24, 25 & 29)	1
24	2412-7	End Clamp	2
25	2116-4	Ball Joint R.H.	1
26	20-9900	Spindle R.H.	1
27	252-52	Needle Bearing	4
28	251-32	Thrust Bearing	2
29	32136-2	Slotted Nut	2
30	3272-17	Cotter Pin	2
31	32151-36	Retaining Ring	2

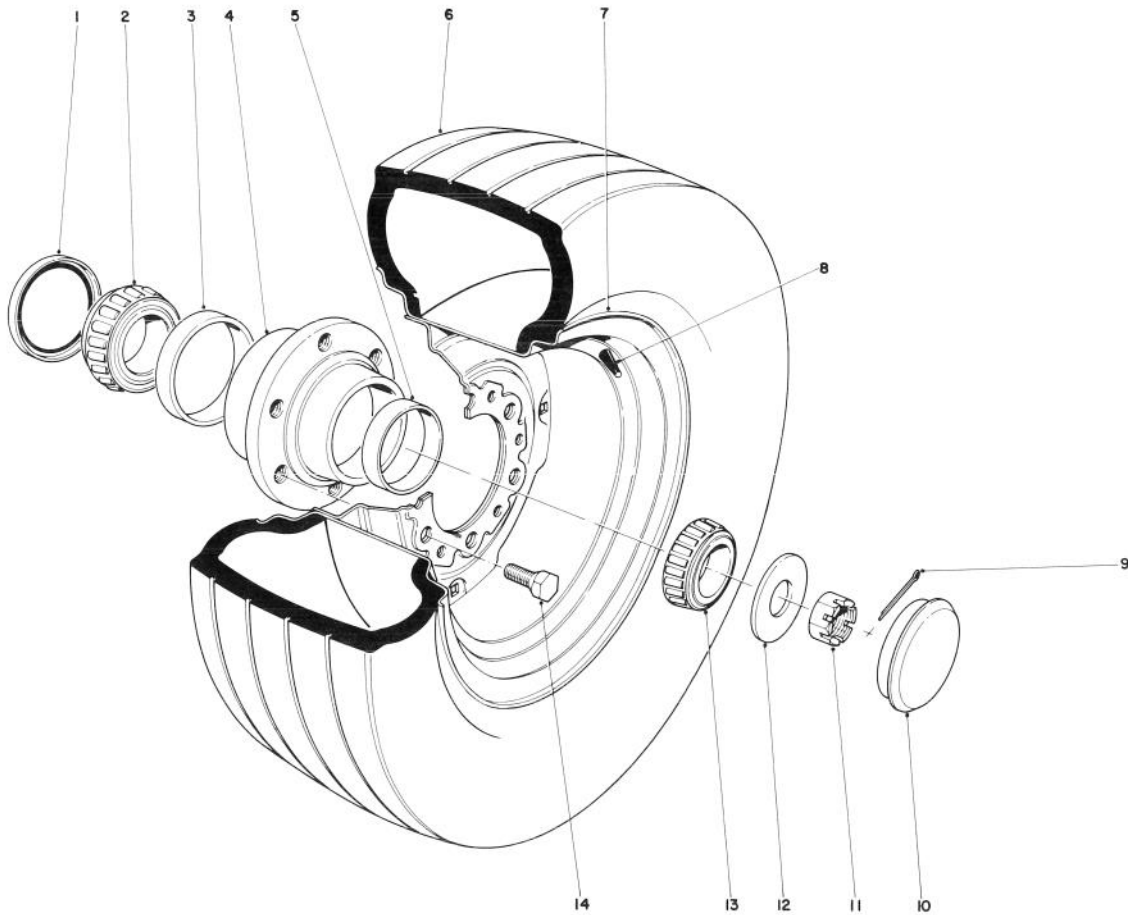

## FRONT WHEEL HUB AND WHEEL — For 9.5 L-14 Tire

Ref. No.	Part No.	Description	No. Used
1	253-100	Grease Seal	2
2	254-75	Inner Bearing Cone	2
3	254-76	Inner Bearing Cup	2
4	217-26	Wheel Hub (Incl. Ref. #3 & 5)	2
5	254-20	Outer Bearing Cup	2
6	56-7950	Tire — Tubeless (9.5L-14)	2
7	10-0720	Wheel (14")	2

Ref. No.	Part No.	Description	No. Used
8	232-27	Valve Stem	2
9	3272-23	Cotter Pin	2
10	217-33	Hub Cap	2
11	32136-1	Slotted Hex Nut	2
12	3256-9	Washer	2
13	254-42	Outer Bearing Cone	2
14	217-34	Wheel Bolt	12

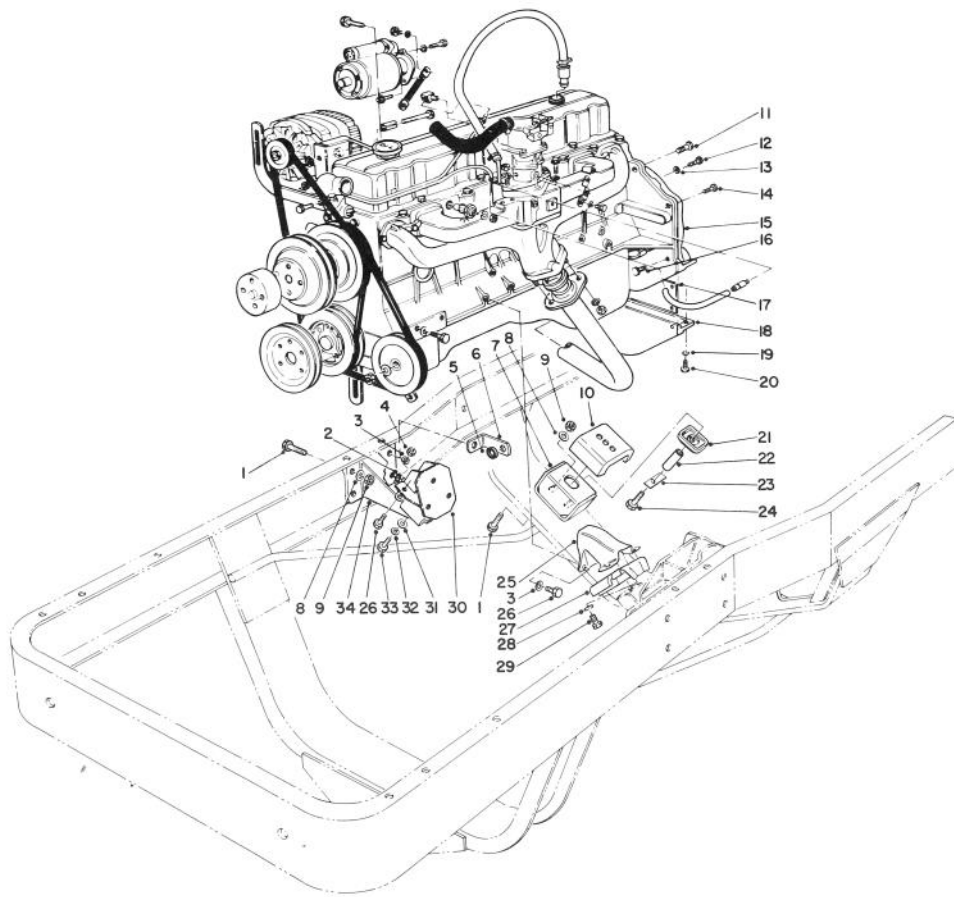

## ENGINE MOUNTING COMPONENTS

Ref. No.	Part No.	Description	No. Used
1	325-6	Capscrew	8
2	3255-2	Lockwasher — External Tooth	1
3	3253-21	Lockwasher	12
4	3217-7	Nut	4
5	237-73	Grommet	1
6	18-2730	Support Fuel Filter	1
7	18-1240	Engine Mount	2
8	3256-26	Flatwasher	8
9	32153-5	Locknut	8
10†	377362	Upper Mount	2
11†	3828782	Capscrew	4
12†	9419054	Capscrew	1
13	18-0180	Lockwasher	1
14	43-2530	Capscrew	2
15†	3925507	Housing Assembly — Clutch	1
16	18-0170	Capscrew	2
17	43-2370	Extension — Clutch Housing	1
18	43-2360	Pan — Clutch Housing	1

Ref. No.	Part No.	Description	No. Used
19	325-3	Lockwasher	5
20	321-2	Capscrew	5
21†	14009321	Lower Mount	2
22†	14009322	Spacer	2
23	46-7480	Lock — Tab	2
24	325-14	Capscrew	2
25†	2043984	Bracket L.H.	1
26	323-4	Capscrew	12
27†	3990332	Front Engine Mount	2
28	21-0370	Lockwasher	1
29	39-7540	Capscrew Mid x 20	1
30	62-7040	Bracket R.H.	1
31	3256-25	Washer	2
32	3253-6	Lockwasher	2
33	324-5	Capscrew	2
34	18-1040	Engine Mount R.H.	1
*	43-2410	Engine 250CC-L6-Chev.	1

†Obtain from your local GM, Chevrolet Dealer.

\*Not Illustrated.

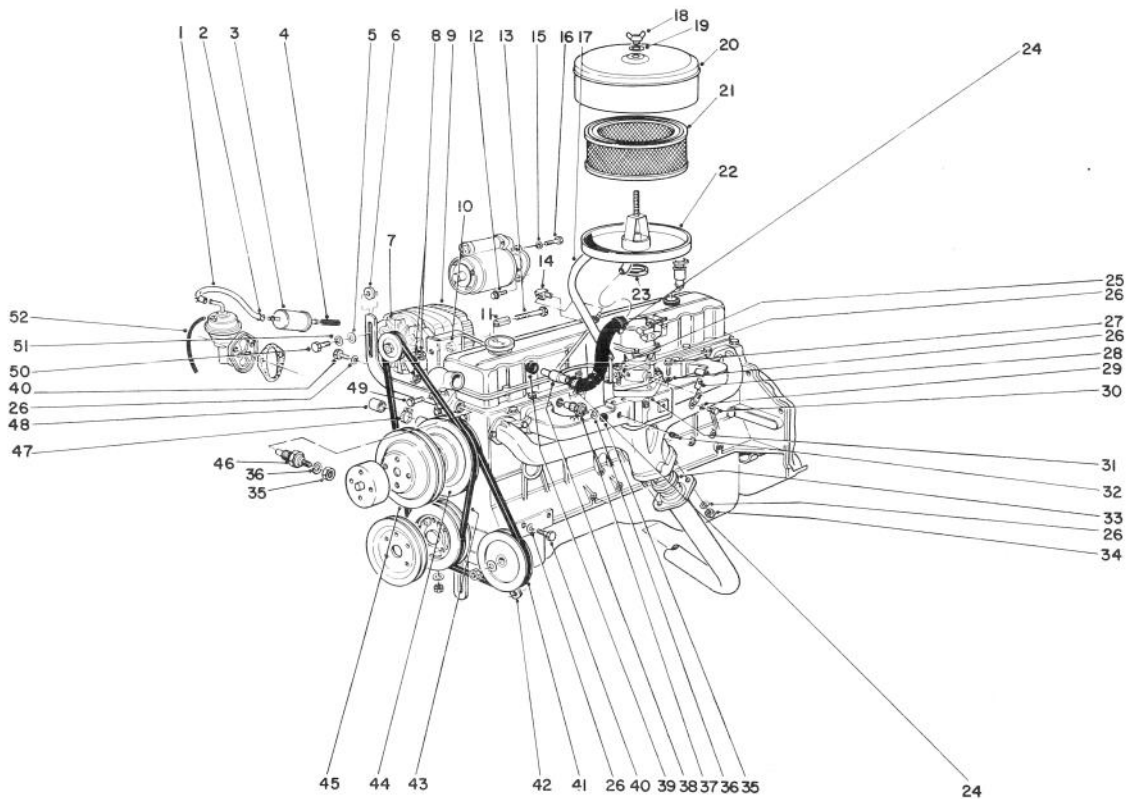

## ENGINE ASSEMBLY

Ref. No.	Part No.	Description	No. Used
1	18-1530	Hose Filter to Pump	1
2	2412-6	Hose Clamp	4
3	18-1520	Fuel Filter (AC5650718)	1
4	18-2400	Fuel Line	1
5	3256-23	Washer — Plain	1
6	5-4460	Washer	1
7	18-1600	Fan Alternator	1
8	32153-2	Locknut	2
9	60-9660	Alternator	1
10	3-8774	Spacer	1
11†	3825451	Alternator Spacer	1
12†	3781994	Capscrew Assembly	2
13	323-16	Capscrew	1
14	353-420	Inverted Flare Fitting	1
15†	138489	Lockwasher	1
16†	9419054	Capscrew	1
17	18-0150	Hose Crankcase	1
18	47-2470	Wing Nut	1
19	47-2460	Washer	1
20	47-2450	Cover	1
21	47-5930	Element	1
22	49-3100	Base	1
23	49-3110	Gasket	1
24	2412-34	Hose Clamp	2
25	3219-3	Nut	2
26	3253-21	Lockwasher	10
27	323-37	Ferry Screw	2

Ref. No.	Part No.	Description	No. Used
28	18-8610	Carburetor Arm Connector	1
29	3253-17	Lockwasher	1
30	3290-237	Capscrew	1
31	18-1510	Carburetor Adapter	1
32	281-2	Pipe Plug Manifold Vac Outlet	1
33†	6271611	Exhaust Pipe Packing	1
34	3217-7	Nut	2
35	3219-14	Nut	2
36	3255-17	Lockwasher	2
37	39-7590	Thermo Switch Assembly	1
38†	6262895	Arrestor	1
39†	3989347	Grommet	1
40	323-4	Capscrew	4
41	18-2020	V-Belt	1
42	38-1860	Strap Pump Adjustment	1
43	18-2030	V-Belt Alternator	1
44†	3995646	Pulley Assembly	1
45†	329671	Pulley (3 Groove)	1
46	38-1680	Water Temp Sending Unit	1
47	2412-34	Hose Clamp	1
48†	1191141	Inlet Cap	1
49	323-6	Capscrew	1
50	21-0350	Capscrew	1
51	3253-4	Lockwasher	1
52	33-0310	Hose Vacuum Advance	1

†Obtain from your local GM, Chevrolet Dealer.

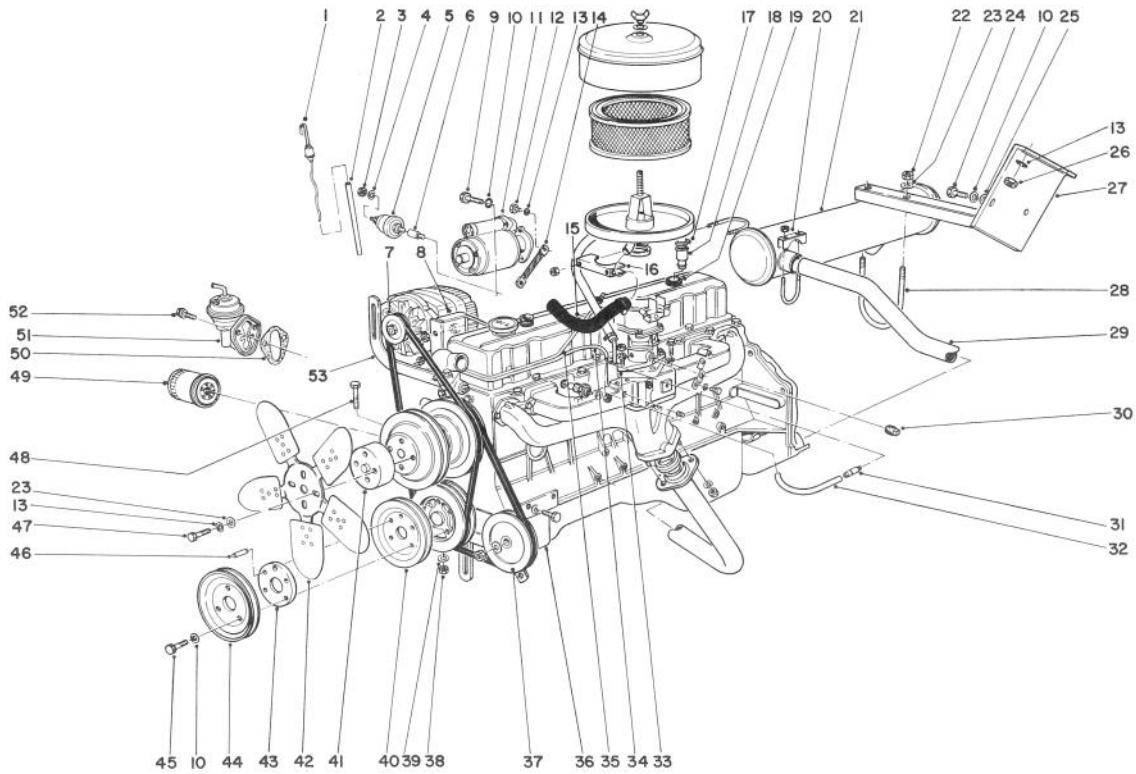

## ENGINE ASSEMBLY

Ref. No.	Part No.	Description	No. Used
1†	3886082	Gauge Assembly Oil Level	1
2†	3886081	Tube — Oil Level Gauge	1
3	3219-14	Nut — Hex	1
4	3255-17	Washer — Lock External Tooth	1
5	18-1760	Sending Unit Oil Pressure	1
6	18-2650	Adapter	1
7	18-1610	Pulley	1
8	18-1080	Mount — Alternator	1
9	323-9	Capscrew	1
10	3253-21	Lockwasher	6
11	55-7470	Starter Motor (Delco Remy No. 1998275)	1
12	322-1	Screw — Cap Hex. Hd.	1
13	3253-4	Washer — Lock	7
14	18-2770	Cable — Ground	1
15	18-1500	Hose — Valve Cover to A/CL	1
16	49-2580	Muffler Clamp	1
17	2412-36	Clamp Hose	2
18	18-1490	Valve Assy. PCV	1
19†	3989344	Grommet	1
20	20-4840	Muffler Clamp	1
21	19-8860	Muffler	1
*	37-4260	Spark Arrestor Muffler (Optional)	1
22	32152-1	Nut — Lock	2
23	3256-23	Washer — Plain	6
24	323-5	Screw — Cap Hex. Hd.	2
25	3256-24	Washer Plain	1
26	32153-3	Nut — Hex	7

Ref. No.	Part No.	Description	No. Used
27	44-2100	Plate — Brake Lever, Muffler	1
28	19-7440	U-Bolt	1
29	19-8850	Exhaust Pipe	1
30	281-1	Plug — Square Hd.	1
31	18-2840	Vacuum Tube	1
32	18-1570	Hose — Vacuum Advance	1
33†	3953732	Carburetor Gasket	2
34	18-1560	Pipe — Vacuum Advance	1
35	18-1580	Gas Pipe Carburetor	1
36	18-1920	Pump Mount	1
37	38-1830	Pulley — Power Steering Pump	1
38	32153-5	Nut — Lock	1
39	3256-26	Washer — Plain	1
40	18-8430	Pulley Crankshaft	1
41	62-6960	Spacer — Fan Blade	1
42	38-6450	Fan — 5 Blade	1
43	18-8420	Adapter Plate — Pulley	1
44†	14025186	Pulley — 4th Groove	1
45	3211-5	Screw — Hex Hd.	3
46	32121-11	Pin — Roll Slotted	2
47	3210-11	Screw — Hex Hd.	4
48	325-9	Screw — Hex Hd.	1
49‡	PF-25	Oil Filter	1
50	18-1550	Gasket — Fuel Pump	1
51	18-1540	Fuel Pump Assembly	1
52†	9440227	Capscrew	2
53	18-1120	Bracket — Alternator Adj.	1

\*Not Illustrated

†Obtain from your local GM, Chevrolet Dealer.

‡Obtain locally

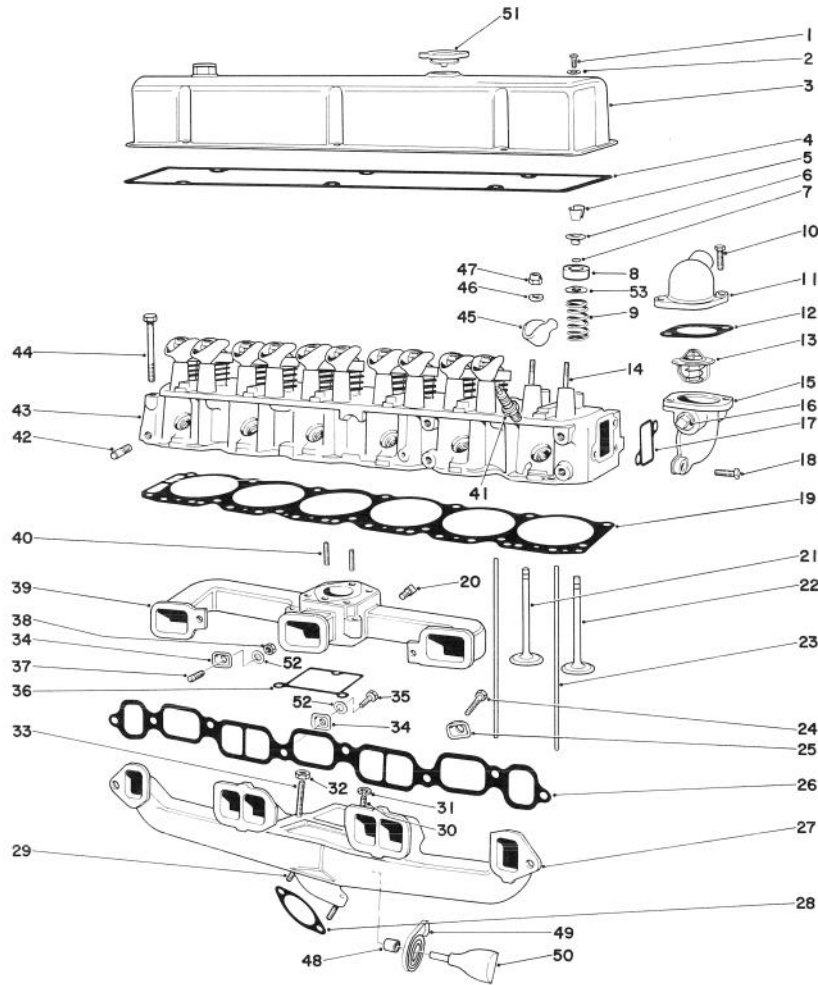

## ENGINE

Ref. No.	Part No.	Description	No. Used
1	180016	Bolt - Valve Rocker Cover	7
2	3877670	Washer Reinforcement	7
3	6259798	Cover Assembly - Valve Rocker	1
4	3930912	Gasket - Valve Rocker Cover	1
5	3947770	Key Valve Stem	24
6	10038209	Cap - Valve Spring	12
7	3835333	Seal - Valve Stem	12
8	10007818	Shield Valve Spring	12
9	3735381	Spring & Damper - Valve	12
10	454905	Bolt - Water Outlet	2
11	3836209	Outlet - Water	1
12	14088907	Gasket - Water Outlet	1
13	3041388	Thermostat Assembly	1
14	3814692	Stud - Rocker Arm (.003 O.S.)	A/R
*	3815892	Stud - Rocker Arm (.013 O.S.)	A/R
15	6270014	Housing Thermostat	1
16	444746	Plug Thermostat Housing	3
17	14079588	Gasket - Thermostat Housing	1
18	454905	Bolt Thermostat Housing	2
19	465893	Gasket Cylinder Head	1
20	3825876	Plug - Inlet Manifold Vacuum Outlet Hole	1

Ref. No.	Part No.	Description	No. Used
21	6263774	Valve - Exhaust (Std.)	6
*	6263775	Valve - Exhaust (.003 O.S.)	A/R
*	6263776	Valve - Exhaust (.015 O.S.)	A/R
*	6263778	Valve - Exhaust (.030 O.S.)	A/R
22	3989088	Valve - Intake (Std.)	6
*	3997749	Valve - Intake (.003 O.S.)	A/R
*	3997750	Valve - Intake (.015 O.S.)	A/R
*	3997751	Valve - Intake (.030 O.S.)	A/R
23	3788495	Rod - Push	12
24	9440954	Bolt - Inlet & Exhaust Manifold Clamp	2
25	3823035	Clamp - Inlet & Exhaust Manifold (at end Exhaust Ports)	2
26	14092392	Gasket - Inlet & Exhaust Manifold	1
27	328599	Manifold Exhaust, Less Studs	1
28	6271611	Exhaust Pipe Packing	1
29	483543	Stud - Exhaust Manifold to Exhaust Pipe	2
30	181648	Bolt Intake to Exhaust Manifold	1
31	120382	Washer - Intake to Exhaust Manifold Bolt	1

\*Not Illustrated

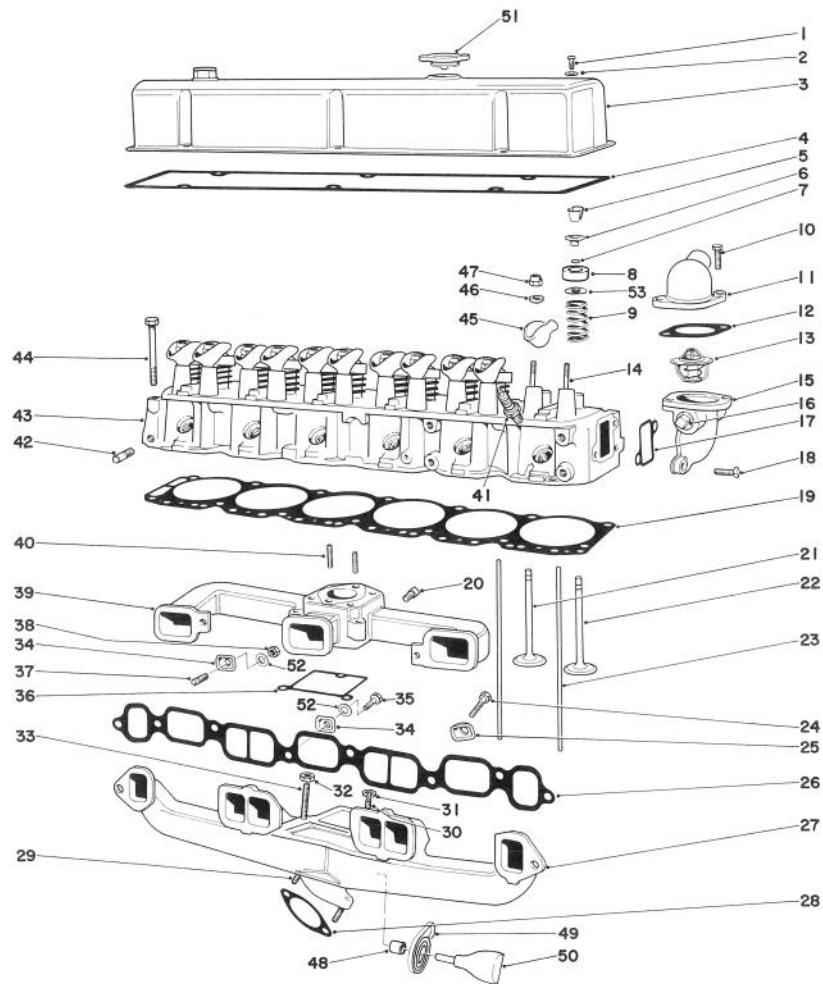

## ENGINE (Continued)

Ref. No.	Part No.	Description	No. Used
32	3866766	Nut - Intake to Exhaust Manifold Stud	2
33	9784982	Stud - Intake to Exhaust Manifold	2
34	3792519	Clamp - Inlet & Exhaust Manifold	4
35	9419059	Bolt - Inlet & Exhaust Manifold Clamp (at end Exhaust Ports)	2
36	343386	Gasket - Exhaust to Intake Manifold	1
37	374183	Stud - Inlet & Exhaust Manifold Clamp	2
38	3866766	Nut - Inlet & Exhaust Manifold Clamp	2
39	14002049	Manifold - Intake	1
40	3973169	Stud - Carburetor	2
41	5613326	Spark Plug Assembly	6
42	3835487	Stud - Manifold Locating	2

Ref. No.	Part No.	Description	No. Used
43	10074167	Head Cylinder	1
44	14079539	Bolt Cylinder Head	14
45	5723551	Arm - Valve Rocker Incl. Ref. #46-47)	12
46	3992294	Ball - Valve Rocker Arm	12
47	465934	Nut - Valve Rocker Arm Adj.	12
48	3848282	Bushing - Exhaust Manifold Valve	2
49	3895015	Spring - Exhaust Manifold Valve Stop	1
50	3881831	Thermostat Exhaust Manifold Valve	1
*	3943670	Connector - Crankcase Vent Hose (Intake Manifold)	1
51	14094764	Cap Oil Fill	1
52	382105	Washer - Incl. Exhaust Manifold	4
53	14042575	Rotator - Exhaust Valve	6

\*Not Illustrated

Note: Obtained from your local GM, Chevrolet Dealer.

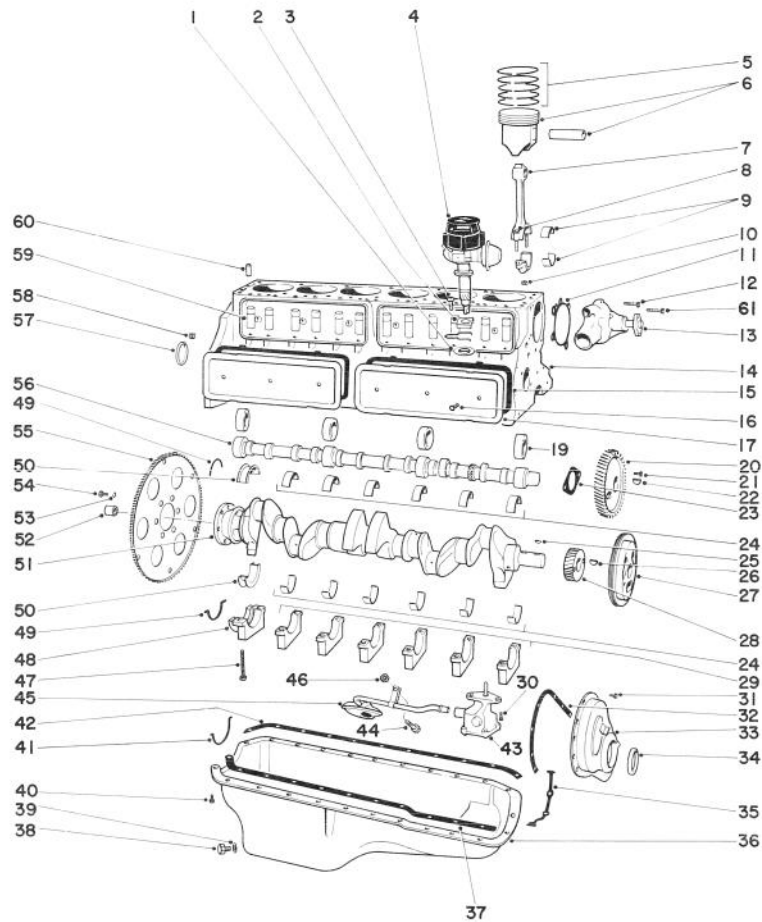

## ENGINE

Ref. No.	Part No.	Description	No. Used
1	6256636	Gasket-Ignition Timer-Distrib.	1
2	355780	Clamp-Ignition Timer-Distrib.	1
3	454905	Bolt-Ignition Timer-Distrib.	1
*	3792285	Washer Distributor Gear Thrust	1
4	1103498	Distributor Assembly	1
*	3792286	Bearing-Distributor Shaft Pilot	1
5	326400	Ring — Piston (1 Per Cylinder) Std.	6
*	328503	Ring — Piston (.030 O.S.) (1 Per Cylinder)	A/R
6	6270033	Piston & Piston Pin Assembly (Std.)	6
*	6270034	Piston & Piston Pin Assembly (.001 O.S.)	A/R
*	6270036	Piston & Piston Pin Assembly (.030 O.S.)	A/R
7	14050551	Rod — Connecting	6
8	14050533	Bolt Connecting Rod	12
9	463259	Bearing—Connecting Rod (Std.)	12
*	463319	Bearing — Connecting Rod (.001 U.S.)	A/R
*	463320	Bearing — Connecting Rod (.002 U.S.)	A/R
*	3715044	Bearing — Connecting Rod (.010 U.S.)	A/R
*	3715047	Bearing — Connecting Rod (.020 U.S.)	A/R
10	527599	Nut Connecting Rod	12

Ref. No.	Part No.	Description	No. Used
11	3788478	Gasket — Water Pump	1
12	443899	Bolt Water Pump Upper & Lower L.H. Side	2
13	14096300	Pump Assembly Water	1
14	14079356	Cylinder & Case	1
15	3920938	Gasket — Push Rod Cover	2
16	3814350	Bolt & Seal Assembly Push Rod Cover	6
17	3788496	Cover — Push Rod	2
19	14002525	Bearing — Camshaft	4
20	3882893	Gear Camshaft	1
21	121753	Screw & Lockwasher — Camshaft Gear	2
22	106751	Key — Camshaft Gear	1
23	10000568	Bearing Unit—Camshaft Thrust	1
24	3829061	Bearing Unit — Crankshaft (Exc. R. R. Std.)	12
*	3829062	Bearing Unit — Crankshaft (Exc. R. R.) .001 U.S.	A/R
*	3829063	Bearing Unit — Crankshaft (Exc. R. R.) .002 U.S.	A/R
*	3829064	Bearing Unit — Crankshaft (Exc. R. R.) .010 U.S.	A/R
*	3829065	Bearing Unit — Crankshaft (Exc. R. R.) .020 U.S.	A/R
*	3829066	Bearing Unit — Crankshaft (Exc. R. R.) .030 U.S.	A/R
25	106751	Key — Crankshaft Gear	1
26	106751	Key — Torsional Damper	1

\*Not Illustrated

16 Note: Obtain from your local GM, Chevrolet dealer.



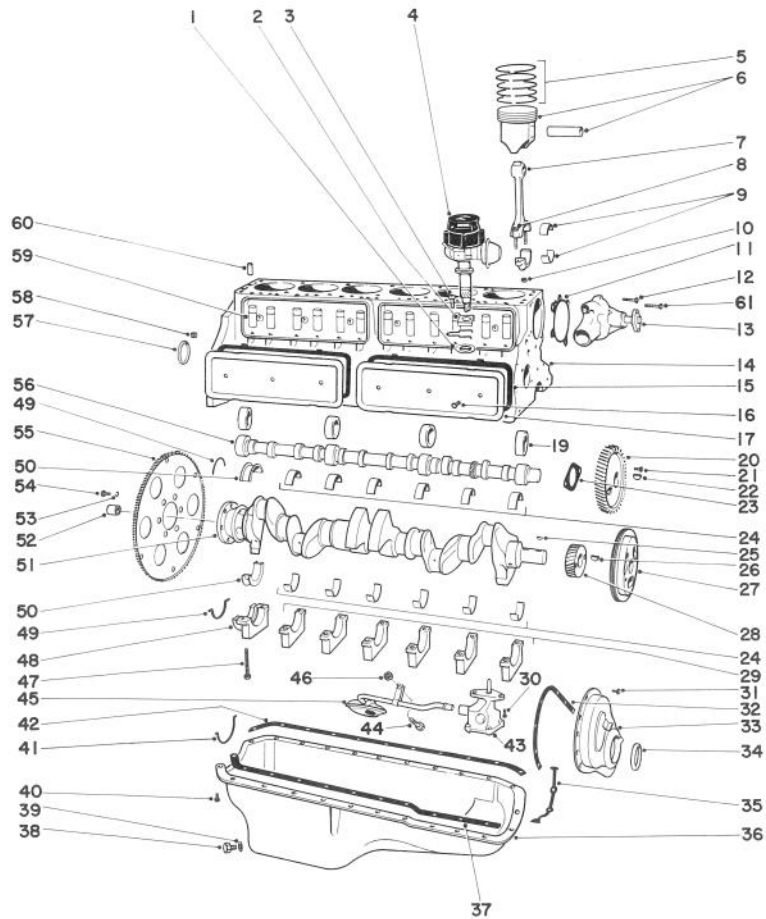

## ENGINE (Continued)

Ref. No.	Part No.	Description	No. Used	Ref. No.	Part No.	Description	No. Used
27	3896590	Damper—Assembly—Torsional	1	*	3930824	Plug — Oil Pressure Regulator Hole	1
28	3882892	Gear — Crankshaft	1	*	3792507	Cover Oil Pump	1
29	3970194	Cap—Crankshaft Main Bearing (Exc. R. R.)	6	*	3789970	Gasket Oil Pump Cover	1
30	9424877	Bolt — Oil Pump & Screen	2	*	133043	Screw Oil Pump Cover	4
31	180016	Screw—Crankcase Front Cover	8	*	9421423	Lockwasher Oil Pump Cover	4
32	14096156	Gasket — Front Cover	1	44	2436161	Bolt—Oil Pump & Screen Support (To Oil Pump Sec. Pipe)	1
33	3996616	Cover — Crankcase Front End	1	45	3859941	Pipe & Screen Assembly Oil Support — Pipe & Screen	1
34	10036286	Seal — Crankcase Front	1	*	3920913	Nut Oil Pump & Screen (To R.H. Stud #6 Crank Bearing Cap)	1
35	3923440	Seal — Oil Pan Front	1	47	3872781	Bolt—Crank Main Bearing Cap	13
36	352156	Pan Oil	1	*	3852870	Stud #6 Bearing R.H. Side	1
37	14091381	Gasket — Oil Pan R.H.	1	*	444782	Bolt — Crank Main Bearing Cap	1
38	3923420	Plug — Oil Drain	1	48	3928975	Cap — Crankshaft Main Bearing (R. R.)	1
39	14090908	Washer Oil Drain Plug	1	49	473424	Seal Assembly — Crankshaft Rear Oil	2
40	180016	Screw — Oil Pan	18	50	3829067	Bearing Unit — Crankshaft R. R. Std.	2
*	180075	Screw — Oil Pan to Case	4	*	3829068	Bearing Unit — Crankshaft R. R. .001 U.S.	A/R
*	180075	Screw—Oil Pan to Front Cover	2	*	3829069	Bearing Unit — Crankshaft R. R. .002 U.S.	A/R
41	3921973	Seal — Oil Pan Rear	1				
42	14091381	Gasket — Oil Pan L.H.	1				
43	3832449	Pump Assembly Oil	1				
*	3829433	Valve Oil Pressure Regulator	1				
*	3814903	Spring — Oil Pressure Regulator Valve	1				
*	103677	Pin Oil Pressure Regulator Valve Retainer	1				
*	3792286	Bearing, Oil Pump Shaft Pilot	1				

\*Not Illustrated

Note: Obtain from your local GM, Chevrolet dealer.

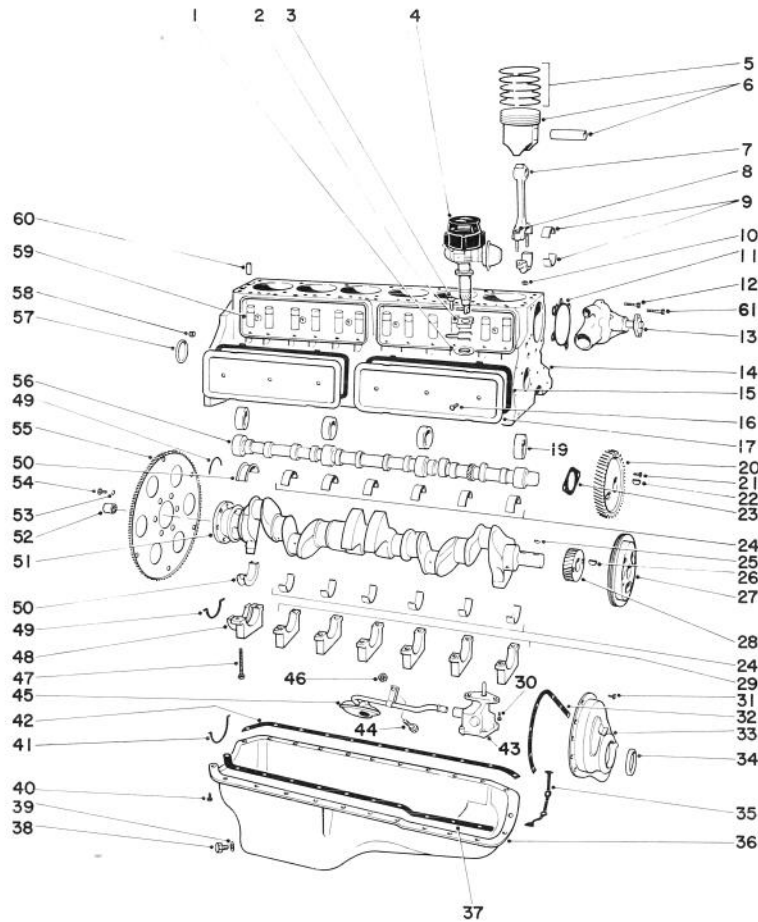

## ENGINE (Continued)

Ref. No.	Part No.	Description	No. Used
*	3829070	Bearing Unit - Crankshaft R. R. .010 U.S.	A/R
*	3829071	Bearing Unit - Crankshaft R. R. .020 U.S.	A/R
*	3829072	Bearing Unit - Crankshaft R. R. .030 U.S.	A/R
51	93400694	Crankshaft Assembly	1
52	3752487	Bearing Clutch Pilot	1
*	3925507	Housing Assembly Clutch	1
*	3828782	Bolt - Clutch Housing	4
*	179848	Bolt - Clutch Housing	2
*	3734908	Extension Clutch Housing Under Pan	1
*	1453658	Pin - Clutch Housing Line Up	2
*	3817006	Screw-Under Pan Extension	5
*	3714477	Under Pan Clutch Housing	1
*	3828848	Plate Assembly Clutch Driven	1
*	3959502	Cover & Plate Assembly Clutch Pressure	1
*	838653	Bolt - Clutch Cover & Pressure Plate	6
†	3253-21	Lockwasher - Clutch Cover & Pressure Plate	6
*	3765372	Fork Assembly - Clutch	1

Ref. No.	Part No.	Description	No. Used
*	3725240	Stud - Clutch Fork Ball	1
*	3765360	Boot - Clutch Fork	1
†53	3255-16	Lockwasher - Flywheel	6
54	839756	Bolt - Flywheel	6
55	3988759	Flywheel Assembly	1
56	3864497	Camshaft Assembly	1
57	3789860	Plug - Water Jacket R.R.	1
*	838538	Plug - Water Jacket Side	3
*	455883	Plug - Cylinder & Case Water Drain Hole	1
58	3994255	Plug - Camshaft R.R. Bearing	1
59	5232810	Lifter Ass'y. Hydraulic Valve	12
60	585927	Pin - Cylinder Head Dowel	2
*	5575416	Valve Assembly Oil Filter By Pass	1
*	3835577	Plug - Cylinder & Case Main Oil Gallery Front Hole	1
*	444782	Plug - Cylinder & Case Main Oil Gallery R.R. Hole	1
*	10000462	Plug - Water Jacket	3
61	180083	Bolt, Water Pump Upper & Lower R.H. Side	2
*	3853870	Connector - Oil Filter	1

\*Not Illustrated

†Obtain from your local Toro Dealer.

**18** Note: Obtain from your local GM, Chevrolet Dealer.

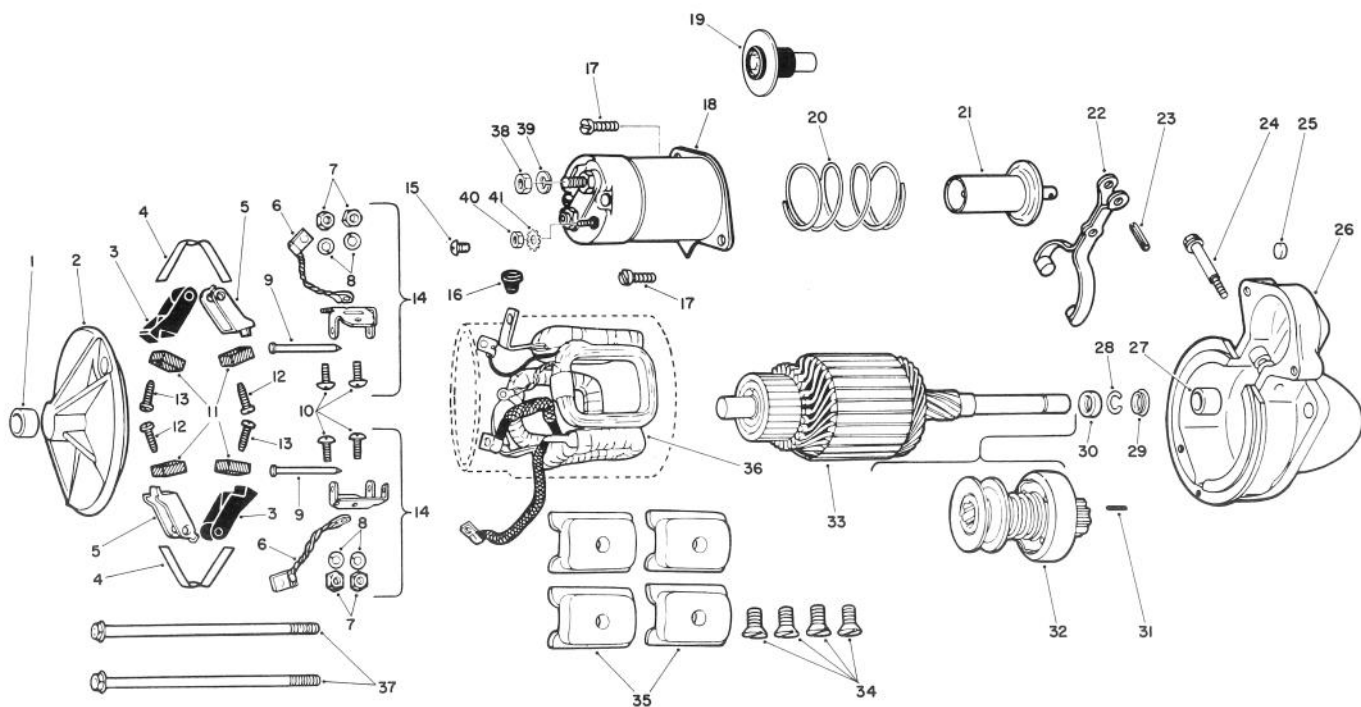

## STARTER MOTOR ASSEMBLY NO. 55-7470

Ref. No.	Part No.	Description	No. Used	Ref. No.	Part No.	Description	No. Used
1	1891927	Bushing C.E.	1	23	1894321	Pin - Lever	1
2	1974157	Frame (Incl. Ref. #1)	1	24	1932197	Stud Lever	1
3	1926618	Holder (Insulated)	2	25	9419572	Plug - Expansion D.E.	
4	1926622	Springs (Brush)	2	26	1970259	Housing Drive (Incl. Ref. #25 & 27)	1
5	1940477	Holder (Ground)	2	27	1984268	Bushing D.E.	1
6	1960864	Lead (Ground)	2	28	1927848	Ring - Retainer	1
7	120361	Nut - Brush Holder	4	29	1927850	Collar Thrust	1
8	453435	Washer - Lock (Brush Holder)	4	30	1927849	Collar Stop	1
9	1966923	Pin - Brush Holder	2	31	809593	Pin Dowl	1
10	274738	Screw - Brush Holder	4	32	1875687	Drive Assembly	1
11	1906945	Brushes	4	33	1971568	Armature	1
12	443527	Screw - Brush (Ground)	2	34	1968396	Screw - Pole Shoe	4
13	1967747	Screw - Brush (Insld)	2	35	1931129	Shoe - Pole	4
14	1928015	Support (Package)	2	36	1974183	Field Coil Assembly	1
15	9439738	Screw Field Lead	1	37	1939970	Bolt	2
16	1893370	Grommet	1	†38	21-0360	Jam Nut	1
17	9413260	Screw - Switch Attaching	2	†39	3255-9	Washer	1
18	1114531	Switch	1	†40	43-5970	Nut	1
19	1978337	Contact Assembly Switch	1	†41	3255-20	Washer	1
20	1978281	Spring (Plunger)	1	†	55-7470	Starter Motor Complete	1
21	1978297	Plunger	1				
22	1951567	Lever Shift	1				

†Obtain part from Toro Distributor.

Obtain other parts from local GM, Chevrolet Dealer, or Delco-Remy Dealer.

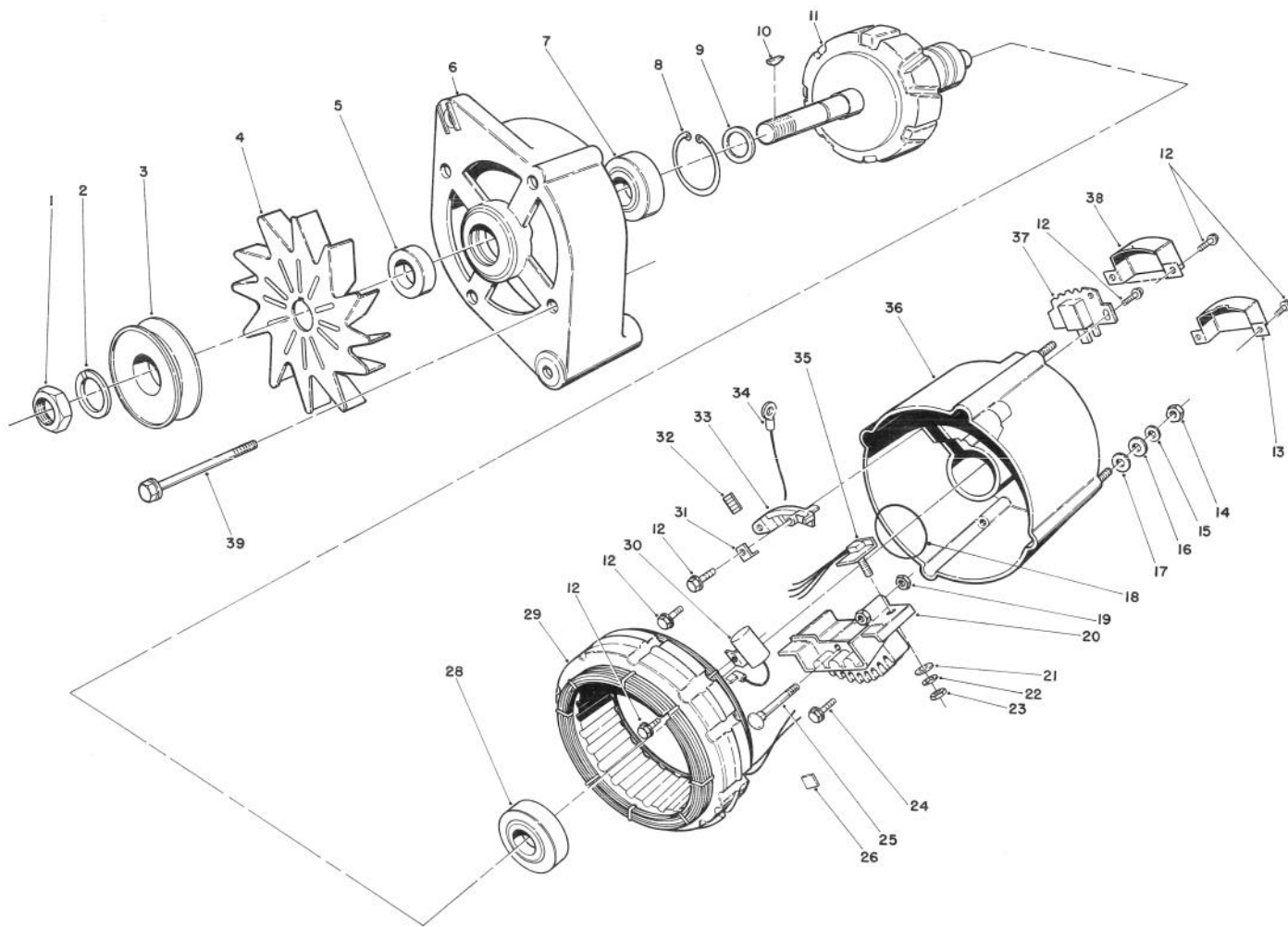

## 62 AMP. ALTERNATOR ASSEMBLY NO. 60-9660

Ref. No.	Part No.	Description	No. Used
1	20-136	Nut, Hex 5/8-18	1
2	20-137	Lockwasher 5/8	1
3		Pulley	1
4		Fan	1
5	20-237	Spacer, Fan	1
6	14-218	Housing, Front	1
7	11-21	Bearing, Front	1
8	11-3	Bearing Retainer	1
9	20-244	Spacer, Rotor	1
10		Key, Woodruff	1
11	12-36	Rotor Assembly	1
12	20-102	Screw, Self Tapping	10
13		Cover Assembly	1
14	20-268	Nut, M 6 x 10	1
15	20-261	Washer	1
16	15-54	Washer	1
17	15-67	Washer Insulator	2
18	11-25	Bearing Retainer	1
19	15-52	Insulator, Bridge Mounting	1

Ref. No.	Part No.	Description	No. Used
20	1-200	Rectifier/Diode Bridge	1
21	15-4	Washer	1
22	20-111	Lockwasher	1
23	20-34	Nut 10-24	1
24	20-245	Screw, Self Tapping	2
25	20-318	Bolt, Carriage M 6 x 10	1
26		Insulator	1
28	11-23	Bearing Rear	1
29	13-43	Stator Assembly	1
30	2-44	Capacitor	1
31	20-247	Clamp	1
32	15-65	Terminal, AC	1
33	15-44	Terminal	1
34	16-109	Cable	1
35	1-129	Diode	1
36	14-219	Housing, Rear	1
37	3-35	Brush Assembly	1
38	5-742	Voltage Regulator	1
39	20-248	Bolt 10-32 x 3	1

Note: Order parts from Motorola Center, 1299 East Algonquin Road, Schaumburg, Illinois 60196.

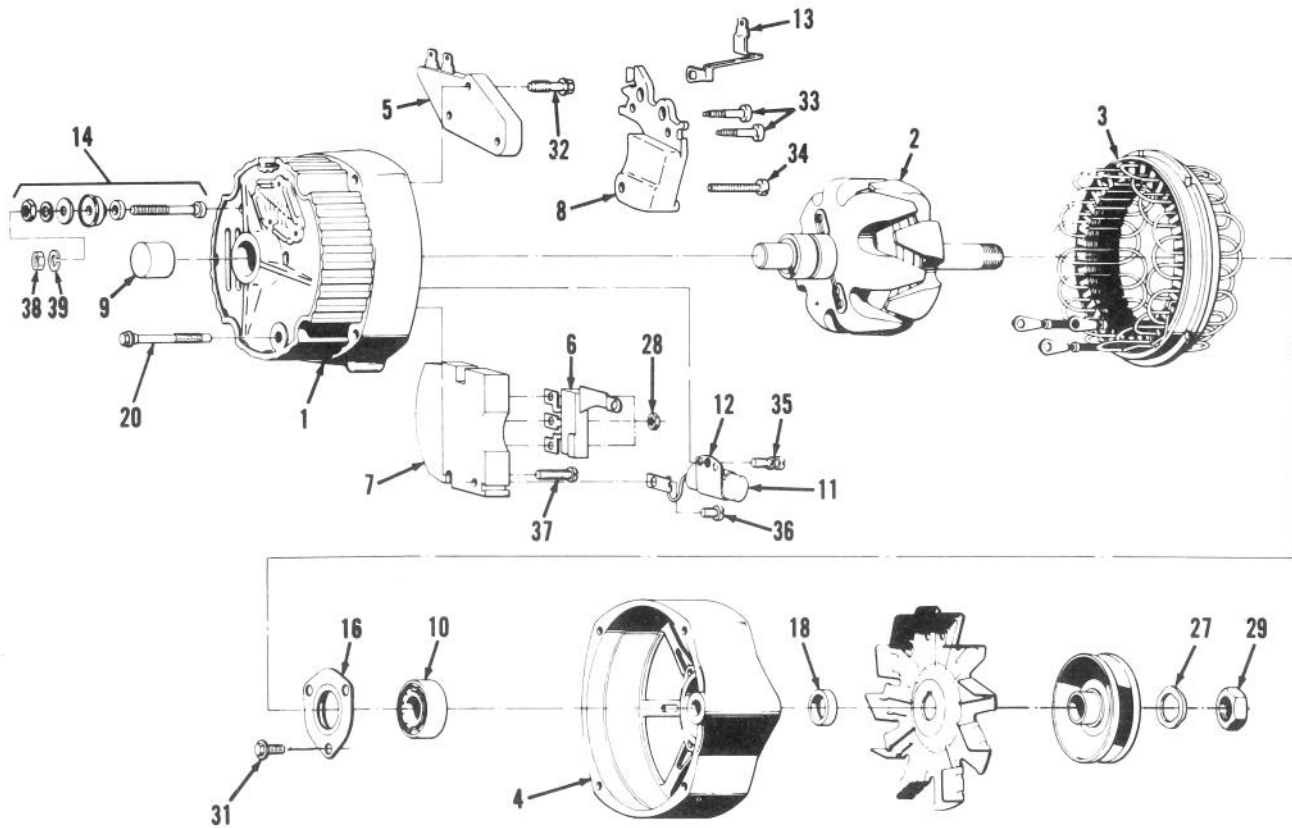

## 42 AMP. ALTERNATOR ASSEMBLY NO. 39-7370

Ref. No.	Part No.	Description	No. Used	Ref. No.	Part No.	Description	No. Used
1	1975718	S.R.E. Frame (Incl. Ref. #9-14)	1	27	1941978	Lockwasher Shaft Nut D.E.	1
2	1876163	Rotor Assembly	1	28	120622	Nut-Rectifier Bridge	3
3	1894594	Stator Assembly	1	29	1915172	Nut-Shaft D.E.	1
4	1976808	Frame D.E.	1	31	1965104	Screw-Bearing Retainer	3
5	1116392	Regulator	1	32	1894586	Screw & Washer - Brush Holder Attaching (Ground)	1
6	1971528	Diode Trio	1	33	1876681	Screw Assy. - Brush Holder Attaching (Insulated)	2
7	1891055	Rectifier Bridge	1	34	1974020	Screw - Brush Holder Attaching Pivot	1
8	1894559	Brush Holder & Brush Ass'y.	1	35	1851612	Screw Capacitor Bracket	1
9	1974862	Roller Bearing - S.R.E.	1	36	1851612	Screw - Capacitor Lead Attaching	1
10	1974861	Ball Bearing D.E.	1	37	1876668	Screw & Washer - Rectifier Bridge Attaching	1
11	1971411	Capacitor	1	‡38	39-7530	Nut	1
12	1869573	Bracket - Capacitor	1	‡39	3254-8	Lockwasher	1
13	1894568	Terminal - Relay	1	‡	39-7370	42 AMP. Alternator Complete	1
14	1975471	Terminal Package	1				
16	1971933	Plate - Ball Bearing Retainer - D.E.	1				
18	1976138	Collar - Shaft Outside - D.E.	1				
20	1956975	Bolt Thru	4				

‡Obtain from local Toro Distributor.

Obtain all other parts from your local GM, Chevrolet Dealer, or Delco-Remy Dealer.

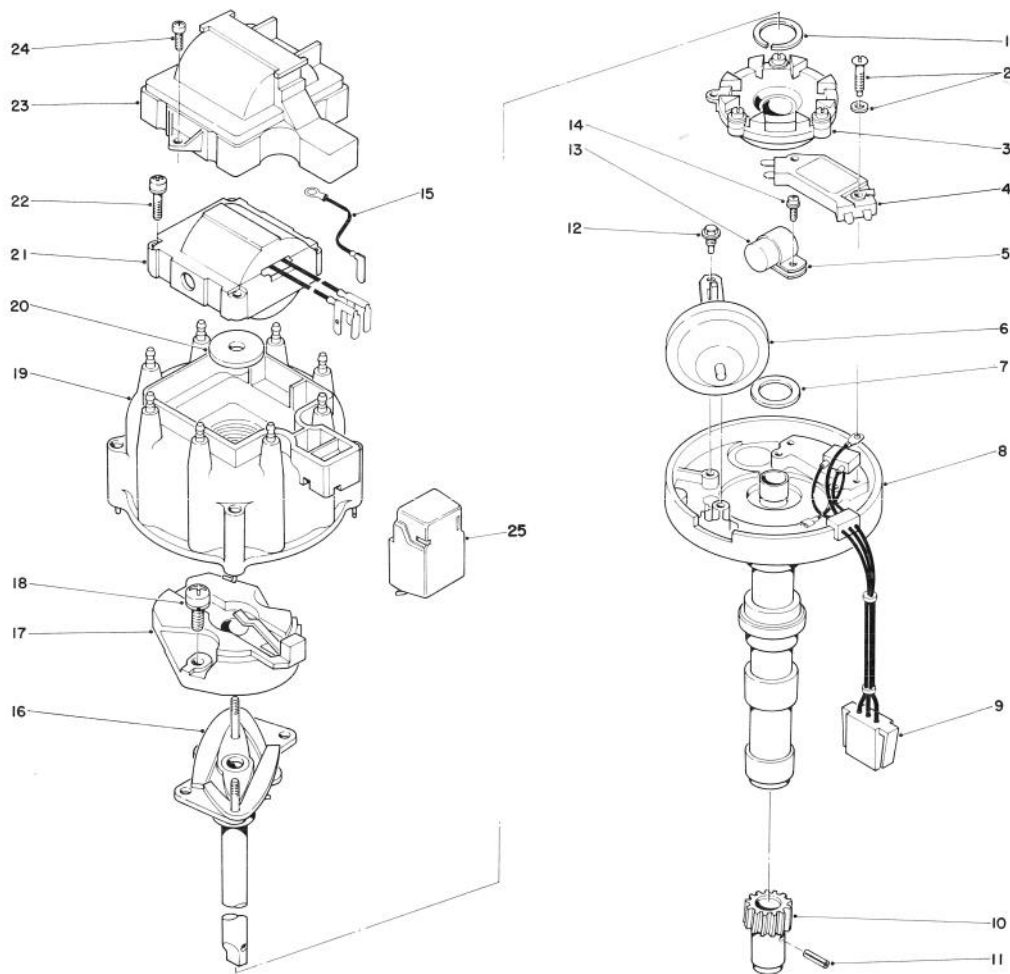

## DISTRIBUTOR ASSEMBLY

Ref. No.	Part No.	Description	No. Used
1	830446	Retainer—Pole PC & Plate (Ring)	1
2	1891234	Screw & Lockwasher — Module Attaching	1
3	1880040	Pole PC & Plate	1
4	1875990	Module	1
5	1869573	Capacitor Bracket	1
†6	1973681	Control Vacuum	1
7	1950569	Seal — Dist. Housing	1
8	1893923	Housing (Incl. Ref. #7)	1
9	1974005	Harness (Incl. Ref. #5 & 13)	1
10	1862052	Gear	1
11	9439551	Pin Gear Attaching	1
12	1891239	Screw Vac Control Attaching	1
13	1876154	Capacitor	1
14	1876639	Screw & Lockwasher — Capacitor Bracket Attaching	1
15	1894868	Lead Ground	1
16	1979879	Shaft & Assembly (Incl. Ref. #17 & 18)	1

Ref. No.	Part No.	Description	No. Used
17	1977026	Rotor (Incl. Ref. #18)	1
18	1875948	Screw & Lockwasher — Rotor Attaching	1
19	1894979	Cap	1
20	1875962	Seal — Under Ign. Coil	1
21	1985473	Coil Assembly	1
22	1985477	Screw & Lockwasher — Ign. Coil Attaching	1
23	1894209	Cover Cap	1
24	1876153	Screw — Dist. Cap Cover Attaching	1
25	465952	Shield — Dist. Splash	1
*	1875967	Brush — Resistor in Cap	1
*	2733648	Pin-Spring — Lower Shaft Extension	1
*	1893524	Shaft — Lower Extension	1
**	1103498	Distributor Assembly	1

\*Not Illustrated.

†Service by complete replacement. Obtain from local GM, Chevrolet, or Delco-Remy Dealer.

\*\*Obtain from local GM, Chevrolet or Delco-Remy Dealer.

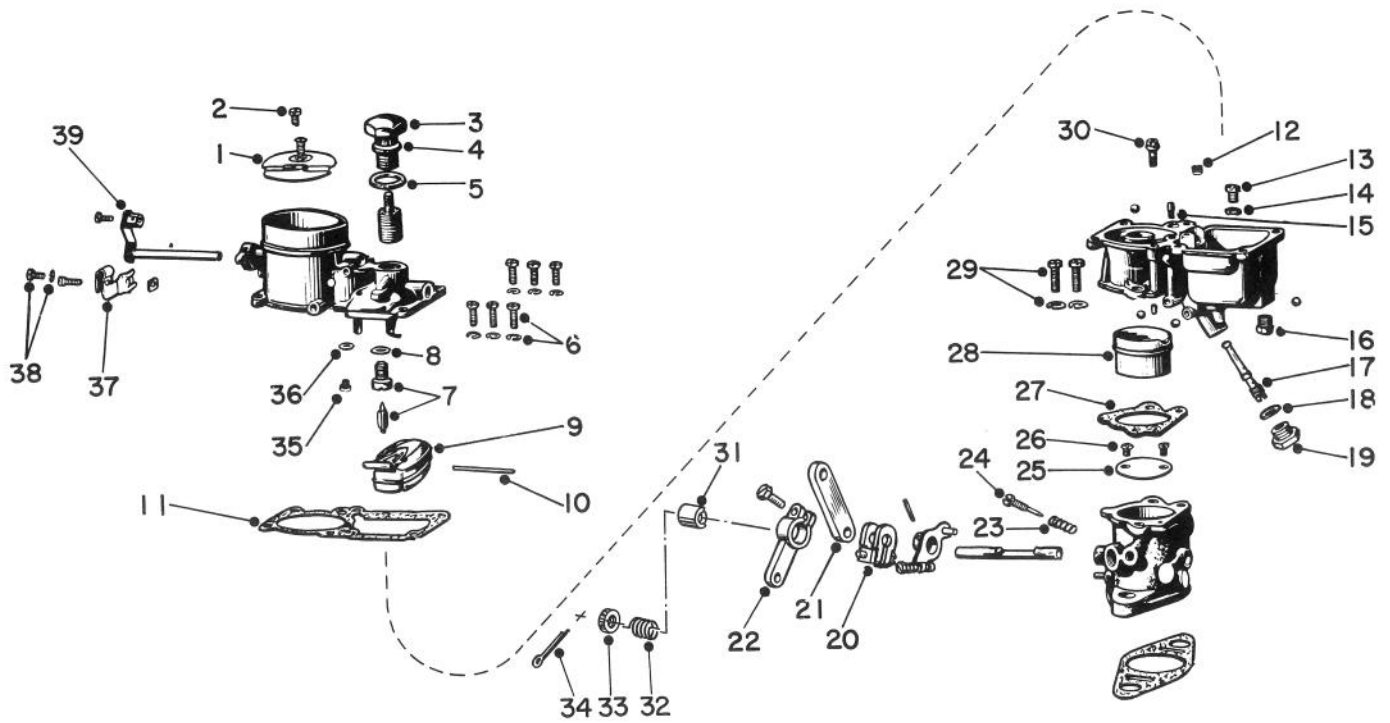

## CARBURETOR ASSEMBLY 18-0740

Ref. No.	Part No.	Description	No. Used
1	18-4770	Plate Assy. (Incl. Ref. #2)	1
		Plate	1
		Air Shutter	1
		Valve Stem	1
		Spring	1
		Spring Return	1
		2	18-4780
3	18-4790	Filter Head Assembly (Incl. Ref. #4, 5, 35 & 36)	1
		Stud & Bottom Washer Assy.	1
		Element Stud	1
		Bottom Washer	1
		Element Disc	150
		Head Washer	1
4	18-4800	Filter Head	1
5	18-4810	Washer	1
6	18-4870	Screw & Lockwasher	6
7	18-5100	Fuel Valve & Seat Assy. (Incl. Ref. #8)	1
		Fuel Valve	1
		Fuel Valve Seat	1
8	18-4900	Washer	1
9	18-4840	Float Assembly (Incl. Ref. #10, 11 & 6)	1
10		Float Axle	1
11	18-4860	Intake Gasket	1
12	18-5230	Plug - Power Jet Valve	1

Ref. No.	Part No.	Description	No. Used
13	18-5060	Main Jet	1
14	18-5070	Washer	1
15	18-5090	Well Vent	1
16	18-4880	Pipe Plug	1
17	18-5220	Discharge Jet	1
18	18-4900	Fibre Washer	1
19	18-4890	Lower Plug	1
20	18-4970	Floating Lever Stop Assembly	1
		Floating Lever Stop	1
		Screw #10-32	1
		Washer	1
		Nut #10-32	1
21	18-4980	Floating Lever	1
22	18-4930	Clamp Lever Assembly	1
		Clamp Lever	1
		Screw #10-32	1
23	18-5040	Spring	1
24	18-5030	Idle Adjustment Needle	1
25	18-4940	Plate	1
26	18-4950	Retaining Screw	2
27	18-4910	Bowl Gasket	1
28	18-5050	Venturi	1
29	18-4920	Screw & Lockwasher	2
30	18-5080	Idle Jet	1
31	18-4990	Driver Bushing	1
32	18-5000	Return Spring	1
33	18-5010	Spring Retainer	1

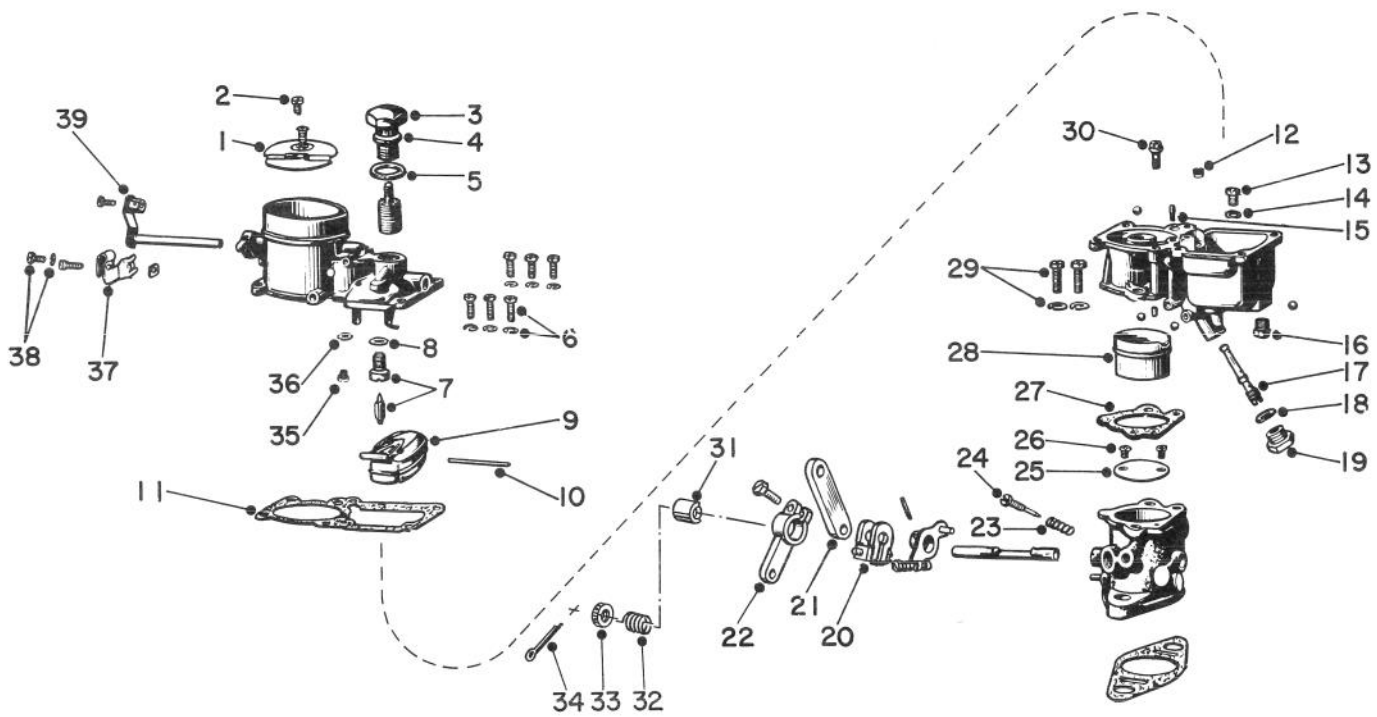

## CARBURETOR ASSEMBLY 18-0740 (Continued)

Ref. No.	Part No.	Description	No. Used
34	18-5020	Cotter Pin	1
35	18-4820	Plug - 1/4-24 (Vac Piston)	1
36	18-4830	Washer	1
37	18-4750	Bracket Assy. (Incl. Ref. #38)	1
		Bracket	1
		Screw #6-32	1
		Nut #6-32	1
38	18-4760	Screw & Lockwasher #8-36	1
39	18-4740	Shaft & Lever Assembly	1
		Shaft	1
		Lever & Swivel Assembly	1
		Lever	1
		Swivel	1
		Screw #8-36	1
*	18-0740	Carburetor (Complete)	1
*	18-5110	Throttle Shaft & Lever Assy.	A/R
		Shaft	1
		Shaft Pin	1
		Stop Lever Assembly	1
		Stop Lever	1
		Lever Bushing	1
		Screw #8-36	1
		Retaining Pin	1
*	18-5120	Gasket Set	A/R
	18-4810	Washer	1
	18-4830	Washer	1
	18-4860	Intake Gasket	1
	18-4900	Fibre Washer	2

Ref. No.	Part No.	Description	No. Used
	18-4910	Bowl Gasket	1
	18-5070	Washer	1
*	38-9540	Carburetor Kit (Incl. Ref. #10)	A/R
	18-4780	Screw #6-32	1
	18-4810	Washer	1
	18-4830	Washer	1
	18-4860	Intake Gasket	1
	18-4900	Fibre Washer	1
	18-4910	Bowl Gasket	1
	18-4950	Retaining Screw	2
	18-5030	Idle Adjustment Needle	1
	18-5070	Washer	1
		F.V. Seat Assembly	1
		Valve Assembly	2
		Steel Ball	1
		Screw	2
		Clip	1
		Gasket	1
		Pump	1
		Cylinder Assembly	1
		Washer	1
		Washer	1
		Gasket	1
		Gasket	1
		Gasket	1
		Washer	1
†	24-5640	Adj. High Speed Jet Assembly	1

\*Not Illustrated

†Optional Equipment



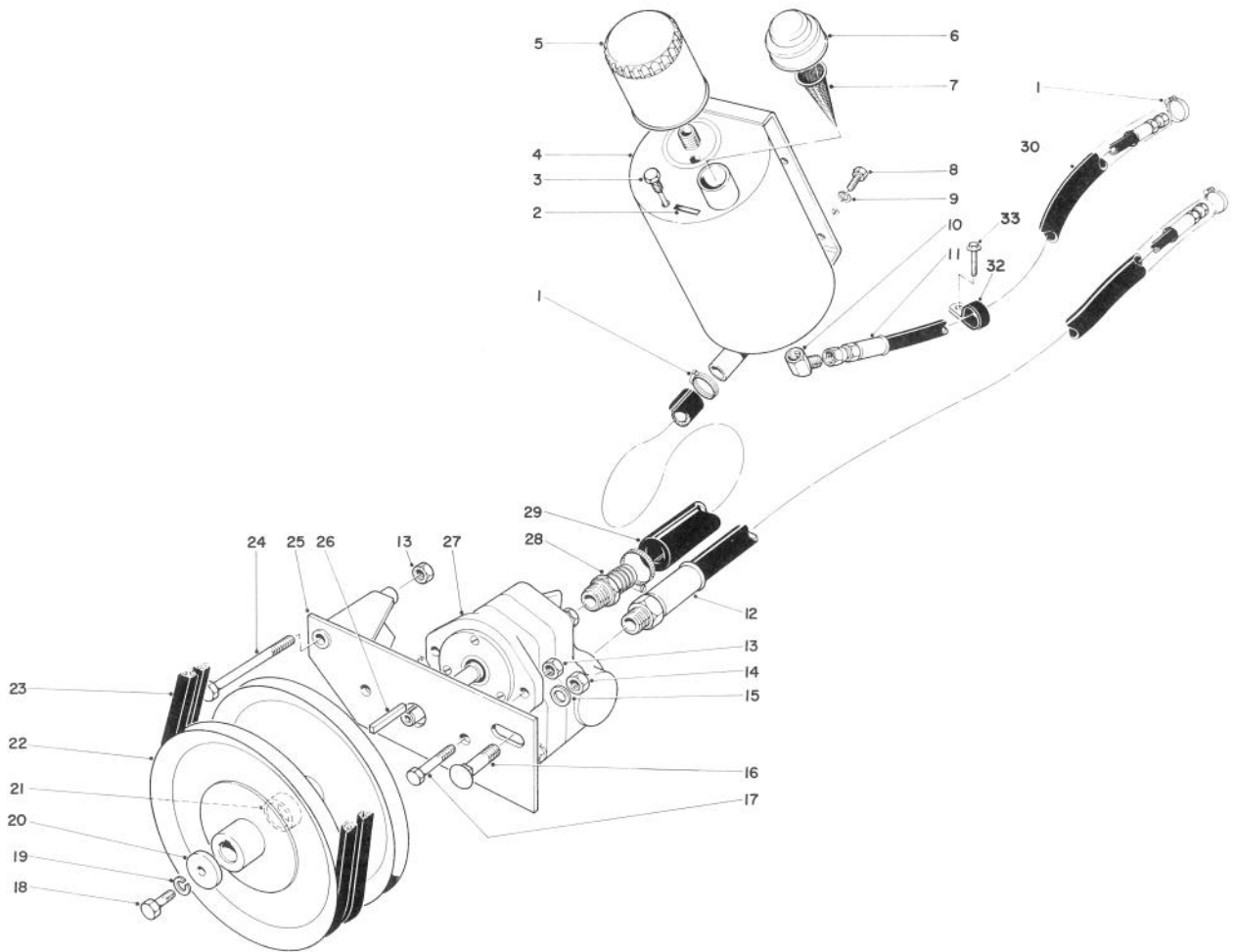

## HYDRAULIC PUMP AND RESERVOIR

Ref. No.	Part No.	Description	No. Used
1	2412-3	Hose Clamp	4
2	3-1553	Decal	1
3	18-2980	Dipstick	1
4	18-2250	Hydraulic Reservoir	1
5	18-4360	Oil Filter (AC #PF-28)	1
6	353-119	Filler Cap	1
7	3-2197	Filler Screen	1
8	32104-6	Self-Tapping Screw	4
9	3253-21	Lockwasher	4
10	353-434	Fitting	1
11	28-9010	Return Hose (77" Lg.)	1
12	36-2480	Pressure Hose (102" Lg.)	1
13	32153-2	Locknut	3
14	32153-5	Locknut	1
15	3256-26	Flatwasher	1
16	3233-1	Carriage Bolt	1

Ref. No.	Part No.	Description	No. Used
17	323-8	Capscrew	2
18	3210-4	Capscrew	1
19	3253-4	Lockwasher	1
20	3-8158	Spacer	1
21	18-8550	Spacer	1
22	18-1990	Pulley	2
23	18-8450	V-Belt (Matched Set)	1
24	323-16	Capscrew	1
25	18-2550	Pump Mount	1
26	6-8590	Square Key	1
27	18-8440	Hydraulic Pump	1
28	3-7195	Coupling	1
29	18-2350	Suction Hose	1
30	28-9020	Sleeve Hose Protection	2
32	2412-64	Clamp Hose	2
33	11-0590	Screw	1

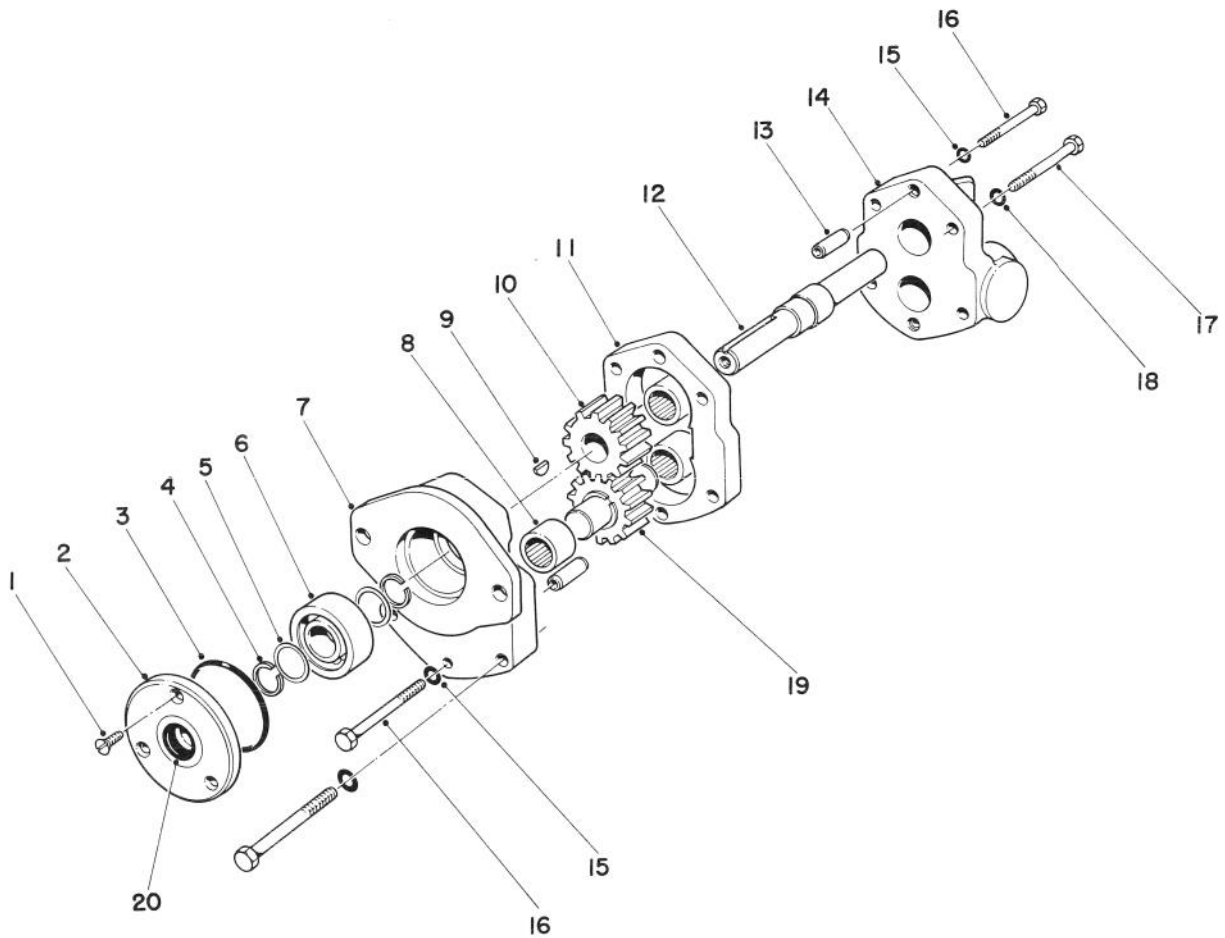

## HYDRAULIC PUMP NO. 18-8440

Ref. No.	Part No.	Description	No. Used
1	18-8460	Screw	3
2	18-8500	Pilot Plate	1
3	24-7260	"O" Ring	1
4	24-7280	Retaining Ring	2
5	24-7270	Washer	2
6	24-7070	Ball Bearing	1
7		Body (Incl. Ref. #8)	1
8	24-7100	Needle Bearing	3
9	24-7120	Woodruff Key	1
10	24-7110	Drive Gear	1
11	24-7200	Gear Plate	1

Ref. No.	Part No.	Description	No. Used
12	18-8490	Drive Shaft	1
13	24-7190	Dowel Pin	2
14		Pump Cover (Incl. Ref. #8)	1
15	3253-3	Lockwasher	2
16	24-7160	Capscrew	2
17	322-10	Capscrew	6
18	3253-4	Lockwasher	6
19	24-7210	Idler Gear	1
20	24-7300	Oil Seal	1
*	18-8440	Hydraulic Pump Complete	1

\*Not Illustrated

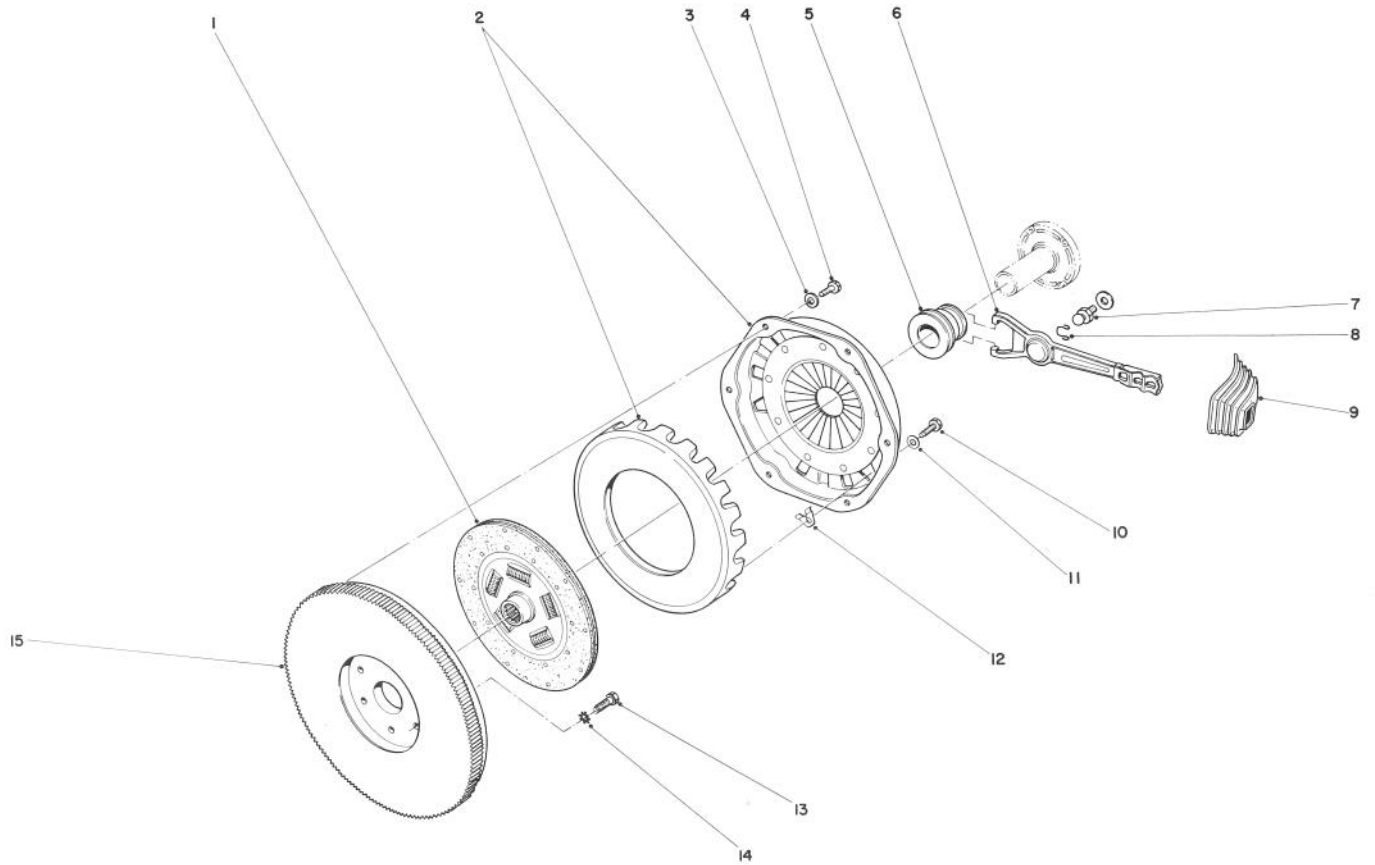

## CLUTCH ASSEMBLY

Ref. No.	Part No.	Description	No. Used
1	3828848	Clutch Plate	1
2	3959502	Cover & Plate Assembly (Incl. Ref. #10-12)	1
*3	3253-21	Lockwasher	6
4	838653	Screw	6
*5	39-3810	Clutch Release Bearing	1
6	3765372	Fork Ass'y. (Incl. Ref. #8)	1
7	3725240	Stud	1

Ref. No.	Part No.	Description	No. Used
8	838987	Ball Retainer Spring	1
9	3765360	Boot	1
10	3702403	Capscrew	3
11	11500191	Lockwasher	3
12	3788605	Retaining Clip	3
13	839756	Capscrew Special	6
14	3255-16	Lockwasher Ext. Tooth	6
15	3988759	Flywheel Assembly	1

\*Obtain from Toro Distributor. Obtain all other parts from GM Chevrolet Dealer.

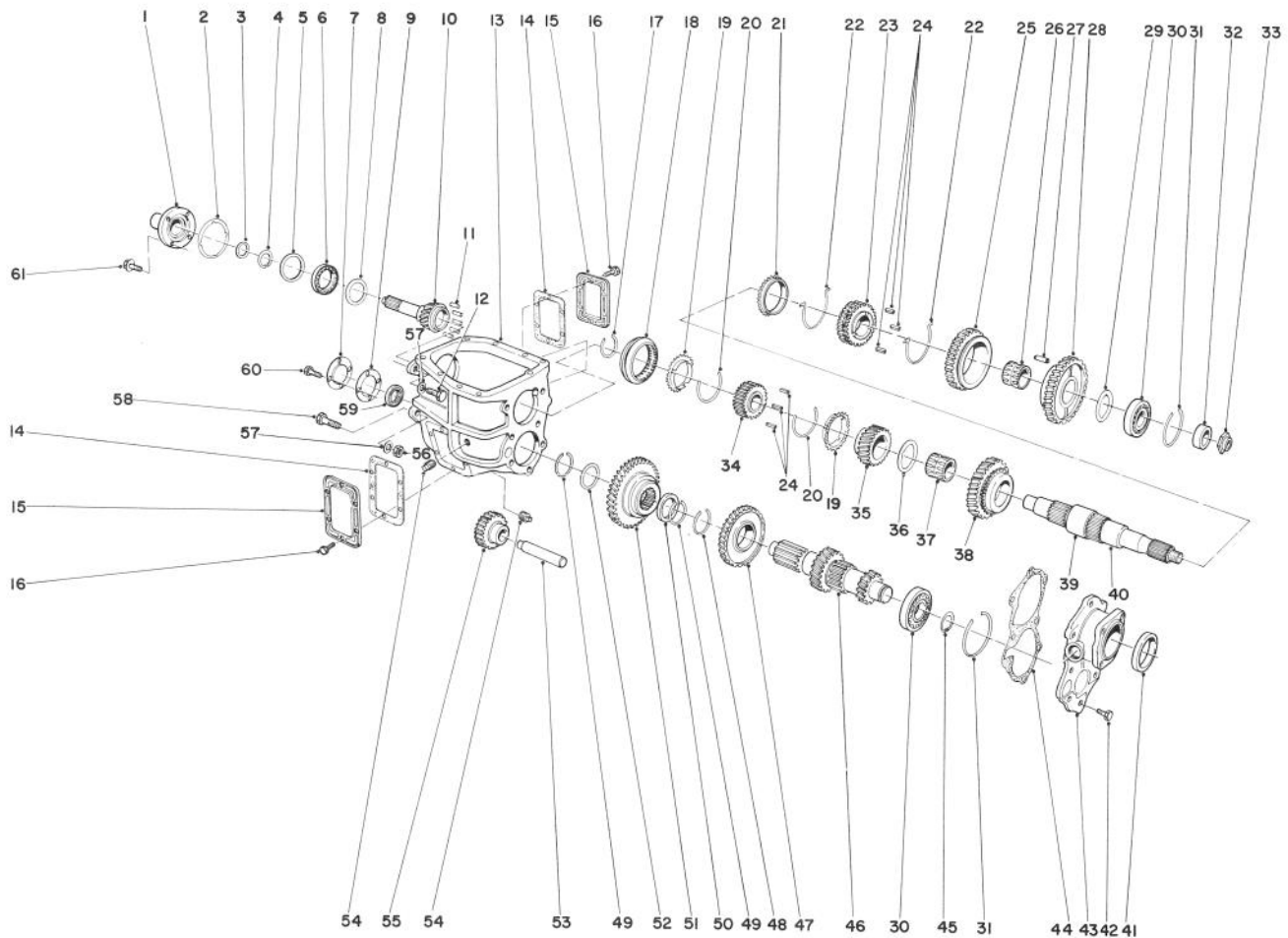

## TRANSMISSION ASSEMBLY NO. 44-1160

Ref. No.	Part No.	Description	No. Used
1	3901178	Retainer Assembly	1
2	3930800	Gasket	1
3	3987937	Seal	1
4	3901152	Ring — Retaining	1
5	3866655	Ring	1
6	907993	Bearing	1
7	3866347	Cap	1
8	3901177	Slinger	1
9	3866348	Gasket	1
10	15588219	Gear — Clutch	1
11	9422666	Bearing — Roller	17
12†	325-6	Capscrew	2
13	465453	Case and Plug Assembly	1
14	6273214	Gasket — Power Take Off	2
15	6273213	Cover — Power Take Off	2
16	15595893	Bolt — Power Take Off Cover	12
17	3901166	Ring	1
18	3901165	Clutch	1
19	3993036	Cone — Gear	2
20	3866359	Spring	2
21	3950367	Cone	1
22	3866646	Spring	2
23	3946776	Hub	1

Ref. No.	Part No.	Description	No. Used
24	3866358	Key	6
25	3901170	Gear — Reverse	1
26	465455	Bushing	1
27	456587	Pin	2
28	476766	Gear	1
29	465450	Thrust Washer	1
30	907474	Bearing	2
31	3830051	Ring	2
32	3866742	Gear	1
33	3830575	Nut Assembly	1
34	3901164	Hub	1
35	3901161	Gear 3rd Speed	1
36	3932267	Washer	1
37	3932274	Bushing	1
38	3901158	Gear 2nd Speed	1
39	3932253	Bushing	1
40	3932265	Shaft	1
41	15595878	Seal	1
42	3911926	Bolt	8
43	15592354	Retainer Assembly	1
44	3930800	Gasket	1
45	3830051	Ring	2
46	14053671	Gear — Counter	1

†Obtain from your local Toro Dealer. Obtain all other parts from your local GM, Chevrolet Dealer.

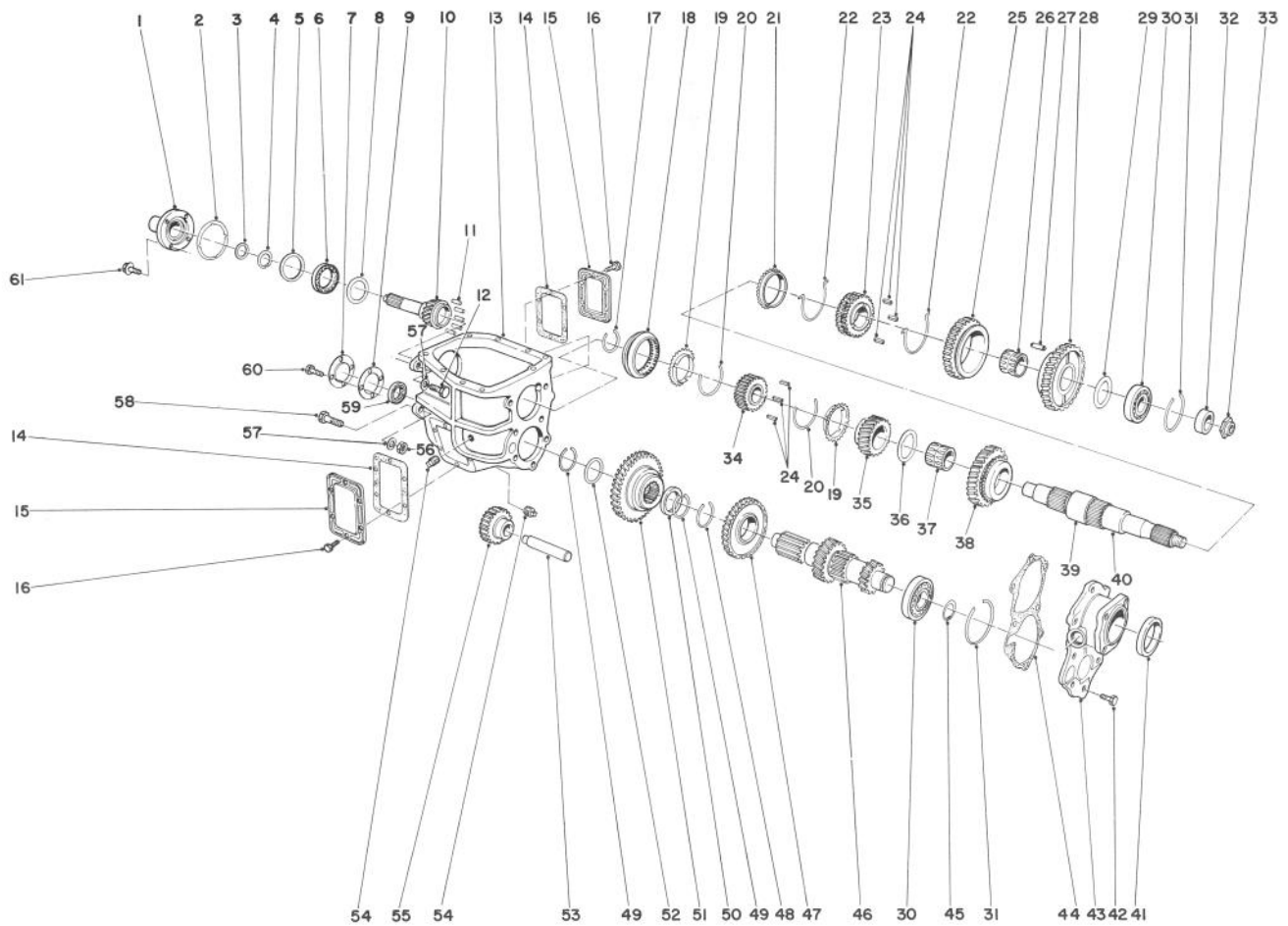

## TRANSMISSION ASSEMBLY NO. 44-1160 (Continued)

Ref. No.	Part No.	Description	No. Used
47	3968038	Gear 3rd	1
48	3866346	Ring	1
49	3920703	Ring	2
50	14020811	Spacer	1
51	3955570	Gear	1
52	3901153	Thrust Washer	1
53	3901144	Shaft – Reverse Idler	1
54	444746	Plug	2
*	444744	Plug (Optional For Item #54)	2

Ref. No.	Part No.	Description	No. Used
55	3901141	Gear Assembly – Reverse Idler	1
56†	3217-9	Nut	2
57†	3253-7	Lockwasher	4
58†	325-7	Screw – Cap, Hex. Hd.	2
59	7451785	Bearing	1
60	435141	Screw	4
61	3920784	Screw & Washer	4

\*Not Illustrated

†Obtain from your local Toro Dealer. Obtain all other parts from your local GM, Chevrolet Dealer.

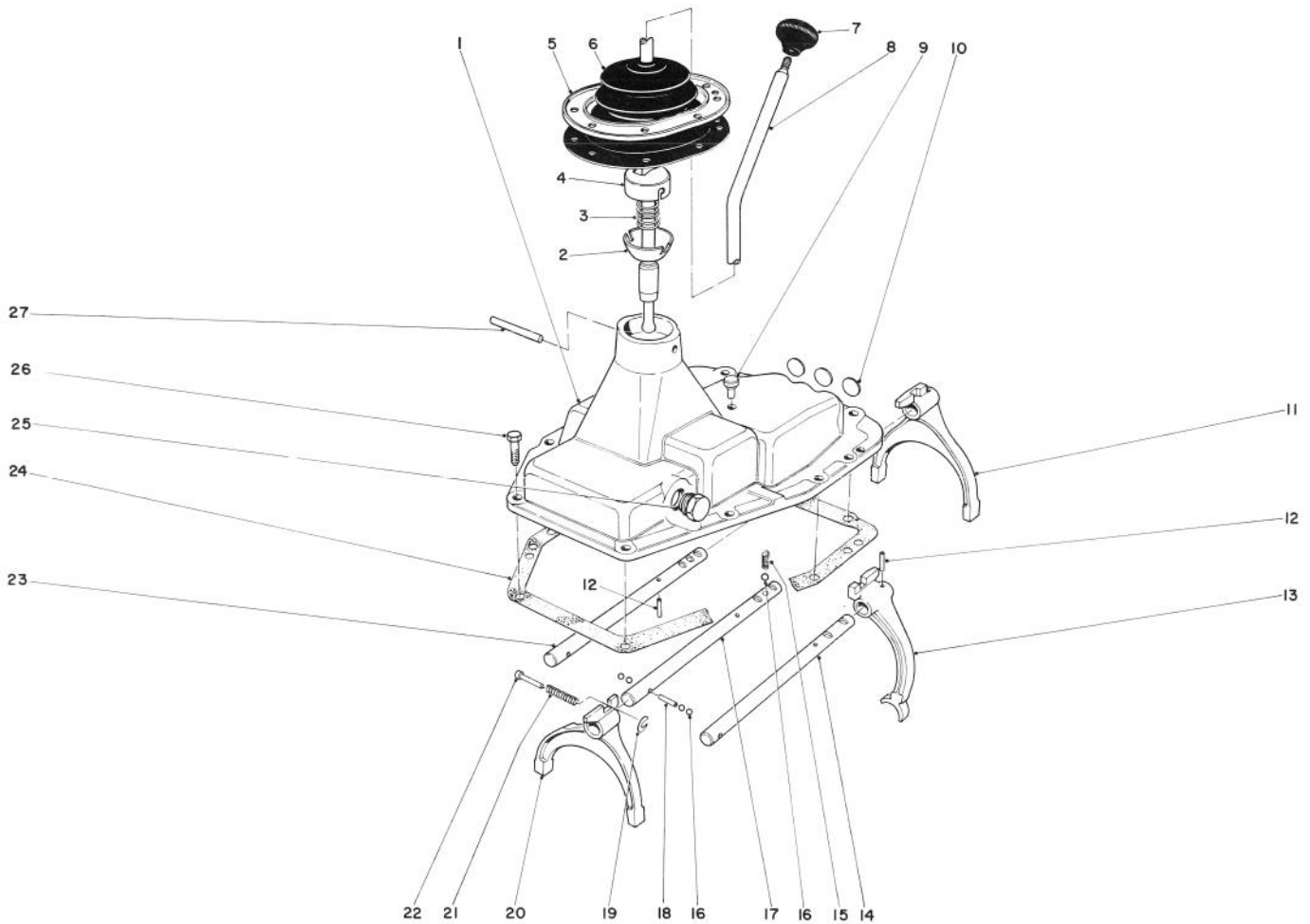

## TRANSMISSION COVER

Ref. No.	Part No.	Description	No. Used
1	3952668	Cover	1
2†	36-9340	Cup Transmission Control	1
3†	36-9330	Spring Transmission Control	1
4†	36-9350	Cap Transmission Control	1
5	378351	Retainer – Transmission	1
6	378340	Boot Transmission	1
7†	233-10	Knob Gear Shift Lever	1
8†	36-9710	Lever Transmission Control	1
9	8640496	Ventilator Assembly	1
10	103894	Plug	3
11	3901137	Fork 1st & 2nd	1
12	273503	Pin	3
13	3978730	Fork Rev.	1
14	15592254	Shaft Rev.	1

Ref. No.	Part No.	Description	No. Used
15	551946	Spring	3
16	453593	Ball	7
17	15592256	Shaft 3rd & 4th	1
18	3901139	Pin	1
19	3727182	Retainer – Rev. Shaft	1
20	3901138	Fork 3rd & 4th	1
21	3978731	Spring	1
22	3864968	Plunger	1
23	15592255	Shaft 1st & 2nd	1
24	15594369	Gasket Transmission Cover	1
25†	36-9430	Plug – Transmission	1
26	3911926	Screw	8
27	456587	Pin	2

†Order from Toro. Obtain all other parts from your local GM, Chevrolet Dealer.

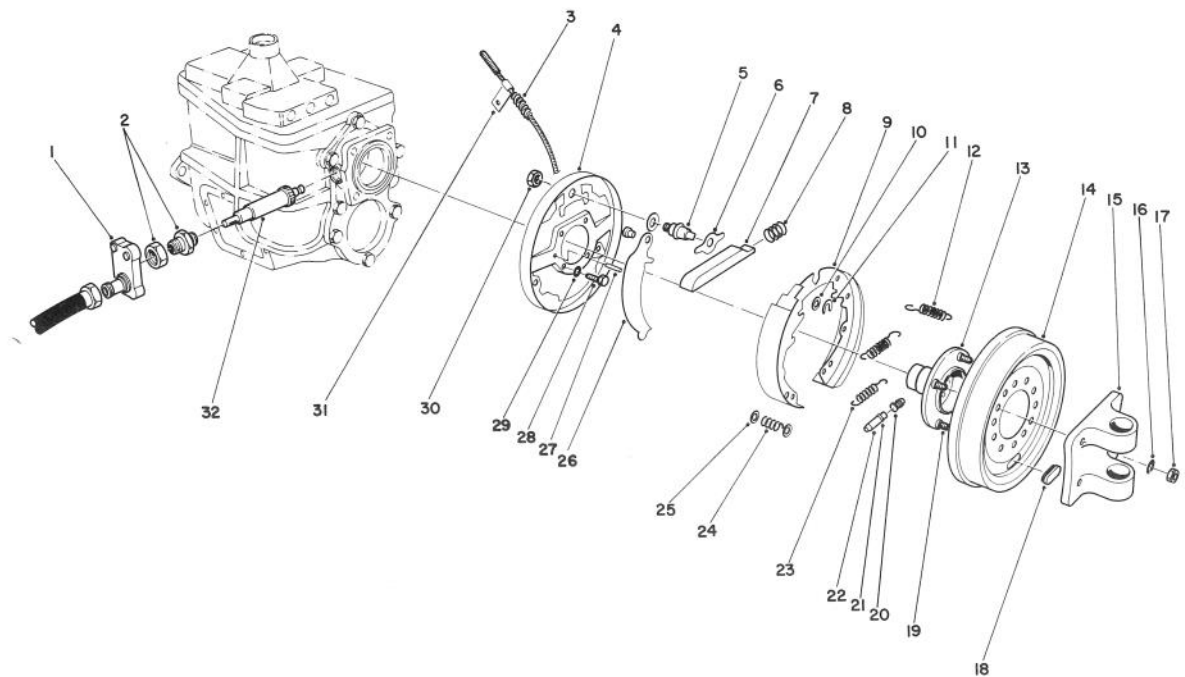

## PARKING BRAKE ASSEMBLY

Ref. No.	Part No.	Description	No. Used
†1	36-9290	Adapter – Gear Reducer Assembly	1
†2	40-9330	Sleeve Assembly	1
3	14067109	Cable Assembly – Transmission Parking Brake	1
4	364690	Backing Plate	1
5	14009982	Pin – Anchor	1
6	18002428	Plate Transmission	1
7	364694	Strut	1
8	1312281	Spring Strut	1
9	1155270	Shoe & Lining	2
10	5454797	Washer – Shoe Lever	1
11	9413523	Clip Lever	1
12	3694822	Spring Shoe Pull Back	2
13	3866674	Flange Assembly	1
14	368009	Drum Assembly	1
†15	44-1150	Flange Yoke	1
†16	3253-21	Lockwasher	4
†17	32152-8	Nut – Lock	4
18	475516	Cover – Brake Shoe Adjustment Hole	1

Ref. No.	Part No.	Description	No. Used
19	3866676	Bolt	4
20	357888	Socket – Shoe Adjustment	1
21	357897	Nut – Shoe Adjustment Pivot	1
22	364692	Screw & Nut Assembly – Shoe Adjustment (Incl. Ref. #20-21)	1
23	3707417	Spring – Shoe Adjustment Screw	1
24	18002399	Spring, Shoe Hold Pin Primary	2
25	5461146	Washer, Shoe Hold Pin Primary	2
26	3866669	Lever	1
27	443770	Pin	1
28	336973	Bolt	4
29	120382	Lockwasher	4
30	3760300	Nut – Transmission	1
31	3866754	Clamp	1
32	3866917	Speedometer Driven Gear	1

†Obtain from your local Toro Dealer. Obtain all other parts from your local GM, Chevrolet Dealer.

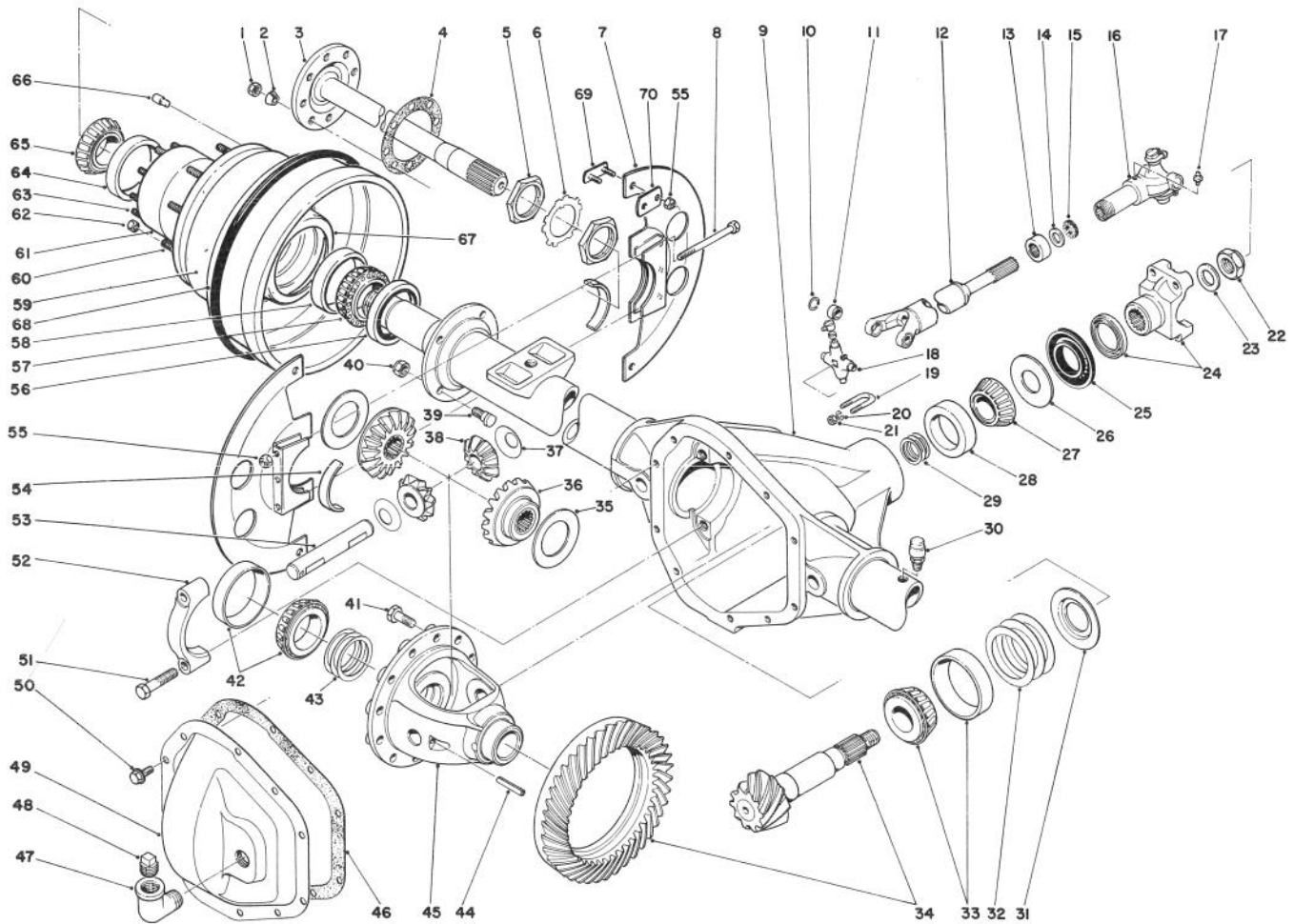

## REAR AXLE (36-9830) AND DRIVE LINE (44-1130)

Ref. No.	Part No.	Description	No. Used
1	3296-7	Locknut	16
2	19-6810	Stud Adapter	16
3	37-8640	Shaft Axle	2
4	24-8660	Gasket Drive Flange	2
5	19-6820	Nut Spindle	4
6	19-6840	Lock — Spindle Nut	2
7	57-6060	Grass Shield	4
8	321-36	Capscrew	4
9		Case Differential Assembly	1
10	18-4650	Retaining Ring	6
11		Bearing Assembly	8
12	44-1140	Shaft Assembly	1
13	18-4730	Retainer Cap	1
14	18-4710	Washer	1
15	18-4700	Felt Dust Seal	1
16	18-4680	Slip Yoke	1
17	18-4690	Grease Fitting	1
18	18-8700	Cross Journal	
		(Incl. Ref. #10 & 11)	2
19	214-229	U-Bolt	2
20	3253-21	Lockwasher	4
21	32152-8	Nut	4
22	18-9360	Nut Pinion	1

Ref. No.	Part No.	Description	No. Used
23	18-9370	Washer Pinion Nut	1
24	19-6700	End Yoke Assembly	1
25	18-9390	Seal Pinion	1
26		Slinger — Pinion Bearing	1
27	18-9410	Bearing Cone	1
28	18-9420	Bearing Cup	1
29	37-8560	Pinion Bearing Shim Kit	1
30	37-7570	Vent	1
31		Baffle — Pinion Bearing	1
32	37-8550	Drive Pinion Adj. Shim Kit	1
33	37-8540	Inner Pinion Bearing Kit	1
34	37-8530	Gear, Pinion & Nut Assembly	
		Hypoid Drive	1
35		Thrust Washer Gear	2
36		Gear Differential	2
37		Thrust Washer Pinion	2
38		Pinion Gear	2
39	19-6830	Brake Flange Bolt	8
40	3296-19	Locknut	8
41	18-9340	Bolt — Drive Gear	12
42	37-8610	Differential Bearing Kit	2
43	37-8590	Differential Bearing Shim Kit	2
44	19-6630	Lock — Differential	1



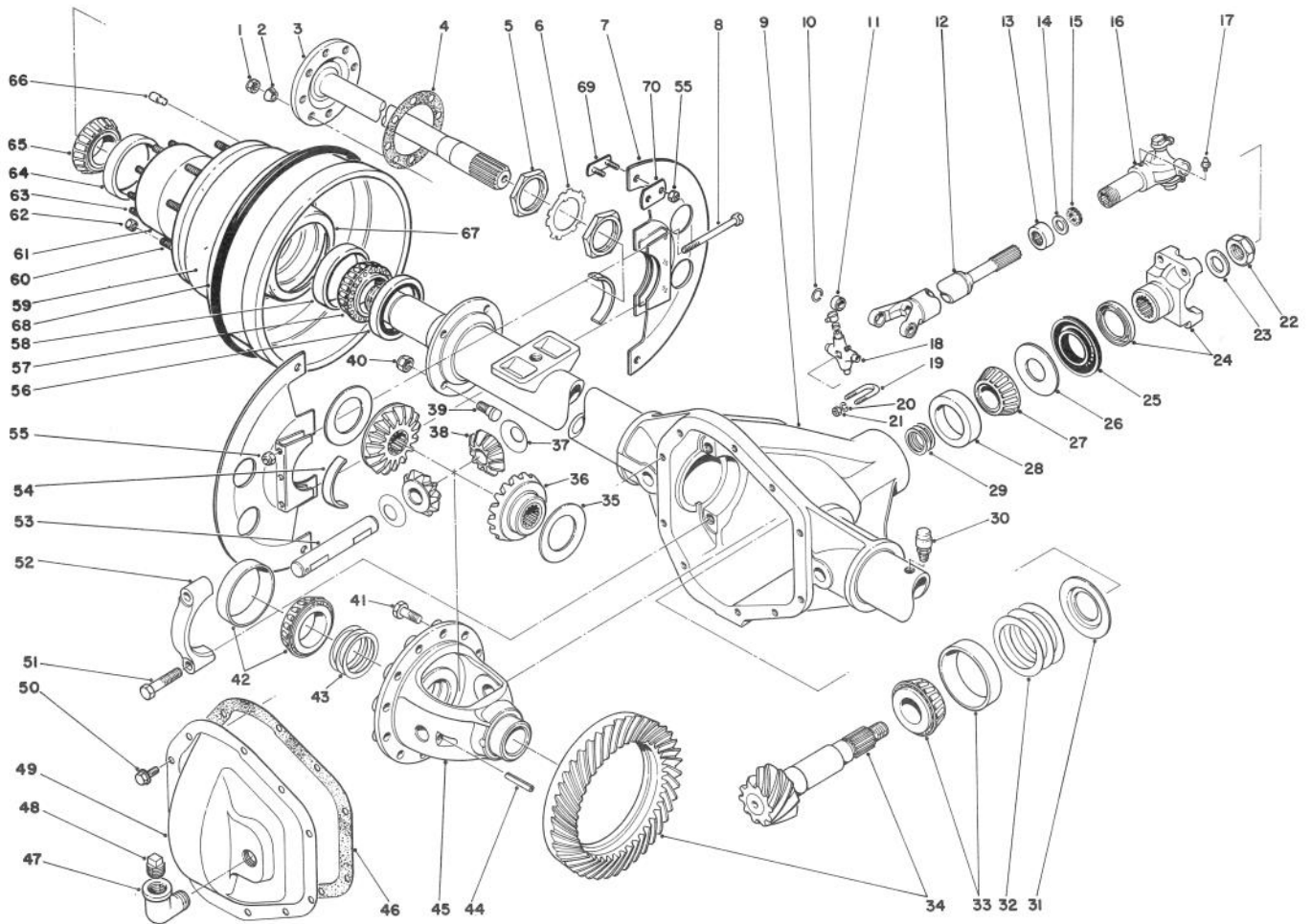

## REAR AXLE (36-9830) AND DRIVE LINE (44-1130) (Continued)

Ref. No.	Part No.	Description	No. Used
		Case Differential	1
45	37-8580	Gasket Carrier Cover	1
47	2811-8	Street Elbow	1
48	19-7090	Pipe Plug	1
49		Gear Carrier Cover	1
50	18-9200	Bolt Carrier Cover	10
51	325-9	Differential Bearing Cup Bolt	4
52		Cup Differential Bearing	2
53		Shaft Differential	1
54	38-2100	Shim	A/R
55	32153-4	Locknut	12
56	253-128	Oil Seal	2
57	254-98	Bearing Cone	2
58	254-100	Bearing Cup	2
59	37-8490	Wheel Drum (Incl. Ref. #58, 63, 64 & 66)	2
60	242-67	Wheel Bolt	16
61	37-8500	Wheel Hub	2
62	242-69	Wheel Nut	16
63	242-68	Flange Stud	16
64	254-99	Bearing Cup	2

Ref. No.	Part No.	Description	No. Used
65	254-101	Bearing Cone	2
66	44-1490	Pin Locating	2
67	54-7670	Slinger	2
68	57-6110	Seal V-Ring	2
69	57-6100	U-Clamp	4
70	57-6070	Strap, U-Clamp	4
*	37-8520	Gear & Pinion Drive Assy. Kit (Incl. Ref. #22-23, 25-29, 31-34, 41, 43 & 46)	1
*	37-8600	Differential Case Assy. Kit (Incl. Ref. #35-38, 41-42, 44-46 & 53)	1
*	37-8620	Differential Parts Kit (Incl. Ref. #35-38, 41, 44, 46 & 53)	1
*	37-8630	Carrier Cover Assembly (Incl. Ref. #46 & 48-50)	1
*	36-9830	Rear Axle (Incl. Ref. #9, 22-38 & 41-53)	1
*	44-1130	Drive Line (Incl. Ref. #10-21)	1
*	505-92	Glue	1
*	505-91	Undercoat	1

\*Not Illustrated

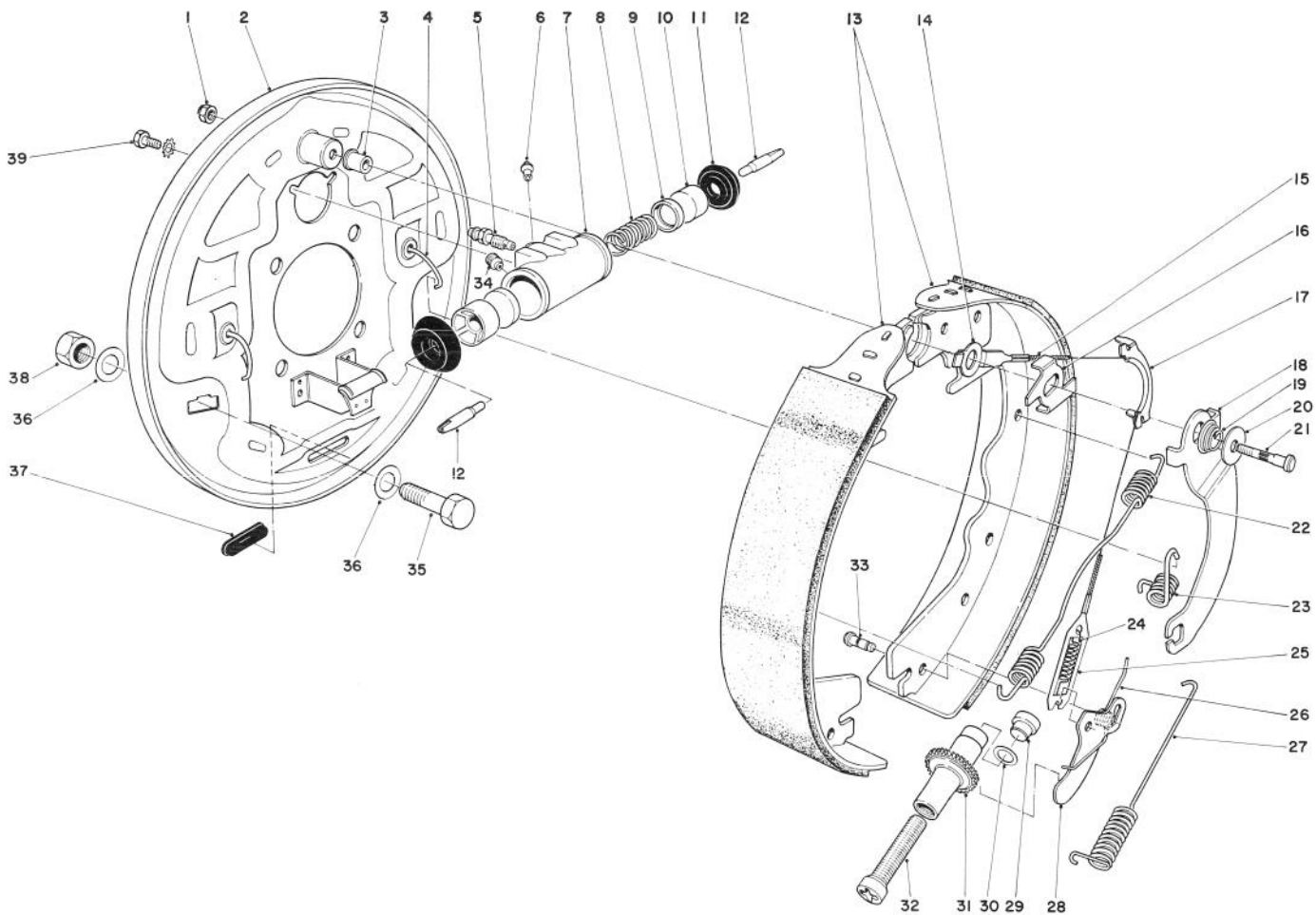

## REAR BRAKE ASSEMBLY (37-1010 R.H. & 37-1020 L.H.)

Ref. No.	Part No.	Description	No. Used
1	37-3770	Locknut	2
2	37-3840	Back Plate & Guide L.H.	1
*	37-3850	Back Plate & Guide R.H.	1
3	37-3710	Bushing Anchor Post	2
4	37-3970	Pin Shoe Hold Down Spring	4
5	19-6460	Bleeder Screw	2
6	19-6450	Tube Seat Inlet	2
7	37-4040	Wheel Cylinder L.H. (Incl. Ref. #5, 6, 8-11 & 34)	1
*	37-4050	Wheel Cylinder R.H. (Incl. Ref. #5, 6, 8-11 & 34)	1
8		Spring	2
9		Cup	4
10		Piston	4
11		Boot	4
12	37-4010	Connecting Link Wheel Cylinder	4
13	40-9250	Shoe & Lining Set Front & Rear	1
14		Fitting Anchor End	2
15		Cable	2
16	37-3690	Cam Plate — Preg. Br. Lever L.H.	1
*	37-3700	Cam Plate — Preg. Br. Lever R.H.	1

Ref. No.	Part No.	Description	No. Used
17	37-3780	Cable Guide	2
18	37-3630	Lever Parking Brake L.H.	1
*	37-3640	Lever Parking Brake R.H.	1
19	37-3620	Spring Anti Rattle Cam & Lever	2
20	37-3600	Washer, Parking Lever Retainer	2
21	37-3610	Anchor Bolt	2
22	37-3990	Spring — Shoe to Shoe	2
23	37-3790	Spring Shoe Hold Down	4
24		Spring Over Travel	2
25		Fitting Lever End	2
26	37-3800	Spring Auto Adjusting L.H.	1
*	37-3810	Spring Auto Adjusting R.H.	1
27	37-4000	Spring Shoe to Shoe	2
28	37-3830	Lever Auto Adjuster	2
29	37-3940	Socket Pivot	2
30	37-3950	Washer Adjusting Nut	2
31	37-3900	Adjusting Nut L.H.	1
*	37-3910	Adjusting Nut R.H.	1
32	37-3920	Pivot Screw L.H.	1
*	37-3930	Pivot Screw R.H.	1
33	37-3820	Pin Auto Adjuster Lever	2

\*Not Illustrated

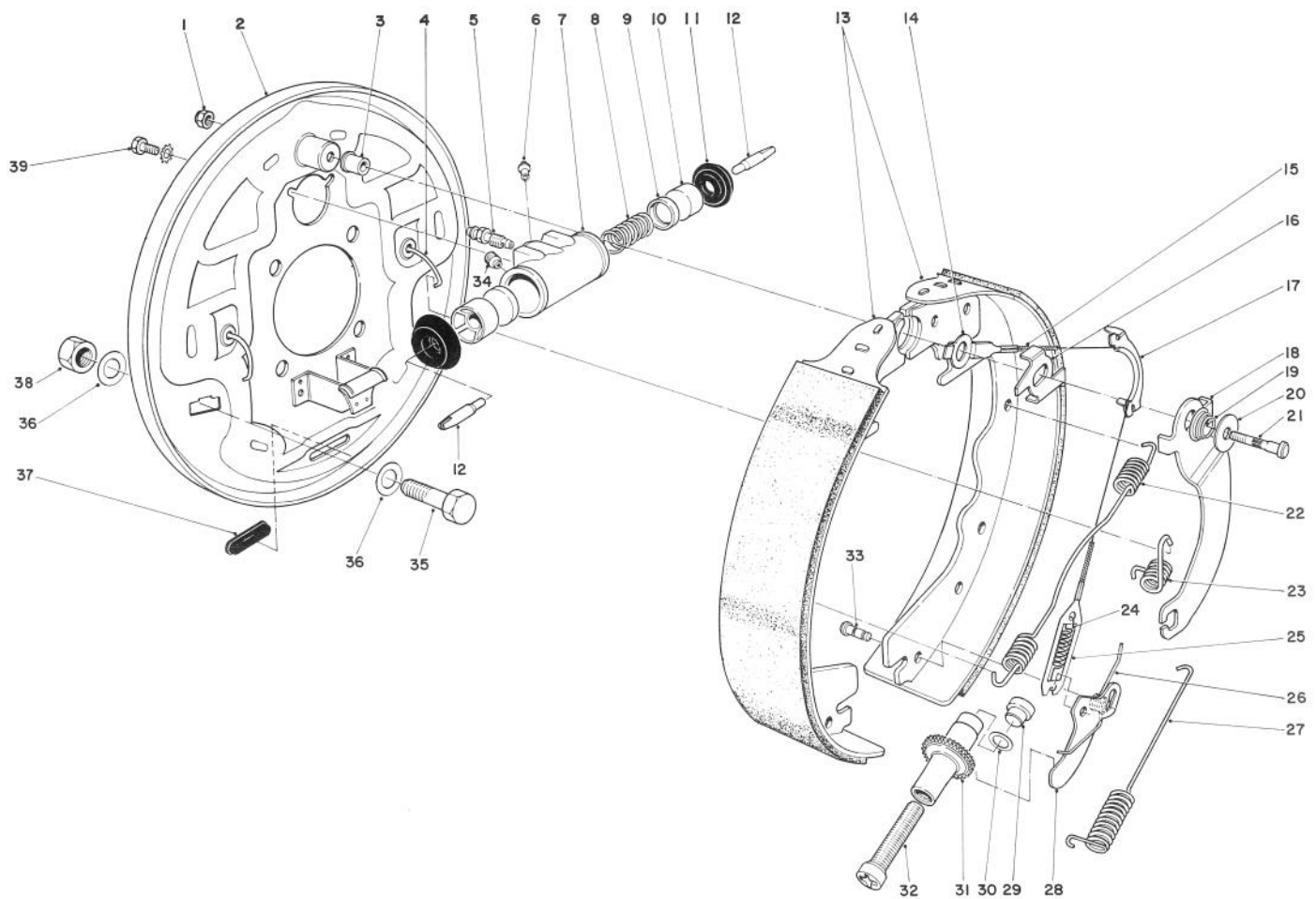

## REAR BRAKE ASSEMBLY (37-1010 R.H. & 37-1020 L.H.) (Continued)

Ref. No.	Part No.	Description	No. Used
34		Body Screw	2
35	325-3	Capscrew	2
36	3256-26	Washer	4
37	37-3960	Cover Adjusting Hole	2
38	32153-5	Locknut	2
39	37-3980	Screw & Lockwasher	1
*	37-3580	Lever Cable Cam Bolt Assy. L.H. (Incl. Ref. #3, 14-16, 18-21 & 24-25)	1

Ref. No.	Part No.	Description	No. Used
*	37-3590	Lever Cable Cam Bolt Assy. R.H. (Incl. Ref. #3, 14-16, 18-21 & 24-25)	1
*	37-3720	Cable & Fitting Assembly (Incl. Ref. #14-15 & 24-25)	2
*	37-1010	Brake Assembly R.H. (Complete)	1
*	37-1020	Brake Assembly L.H. (Complete)	1

\* Not Illustrated

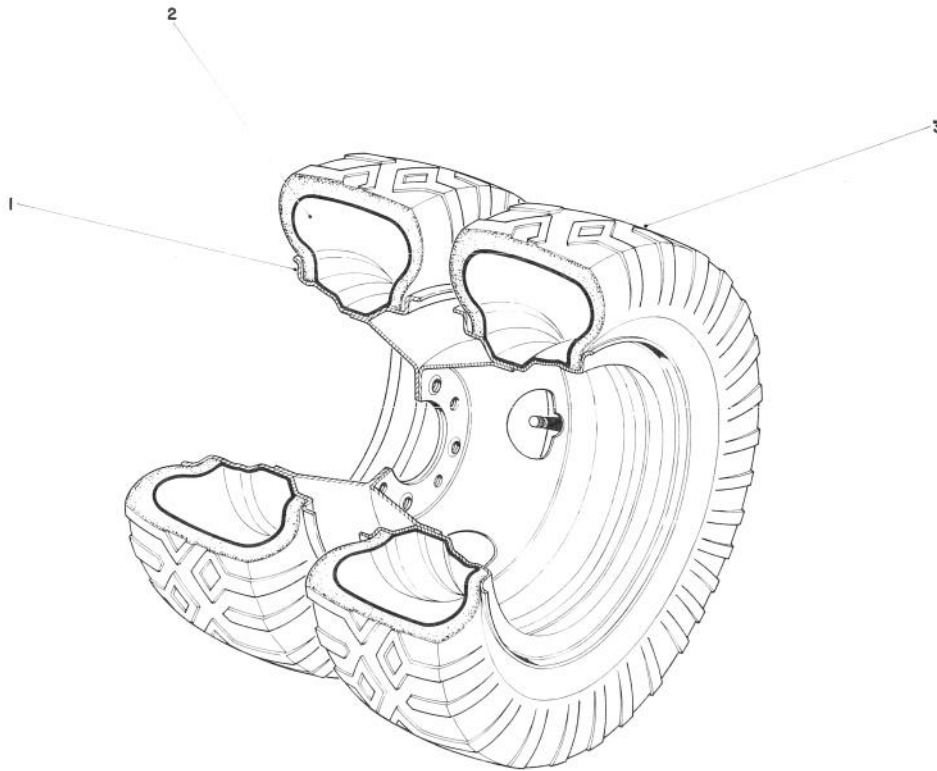

**REAR TIRES AND RIMS 7.50 X 16 FIELD INSTALLED KIT NO. 70230**

Ref. No.	Part No.	Description	No. Used
1	37-4320	Wheel Assembly	4
2	28-9650	Inner Tube	4

Ref. No.	Part No.	Description	No. Used
3	231-5	Tire	4

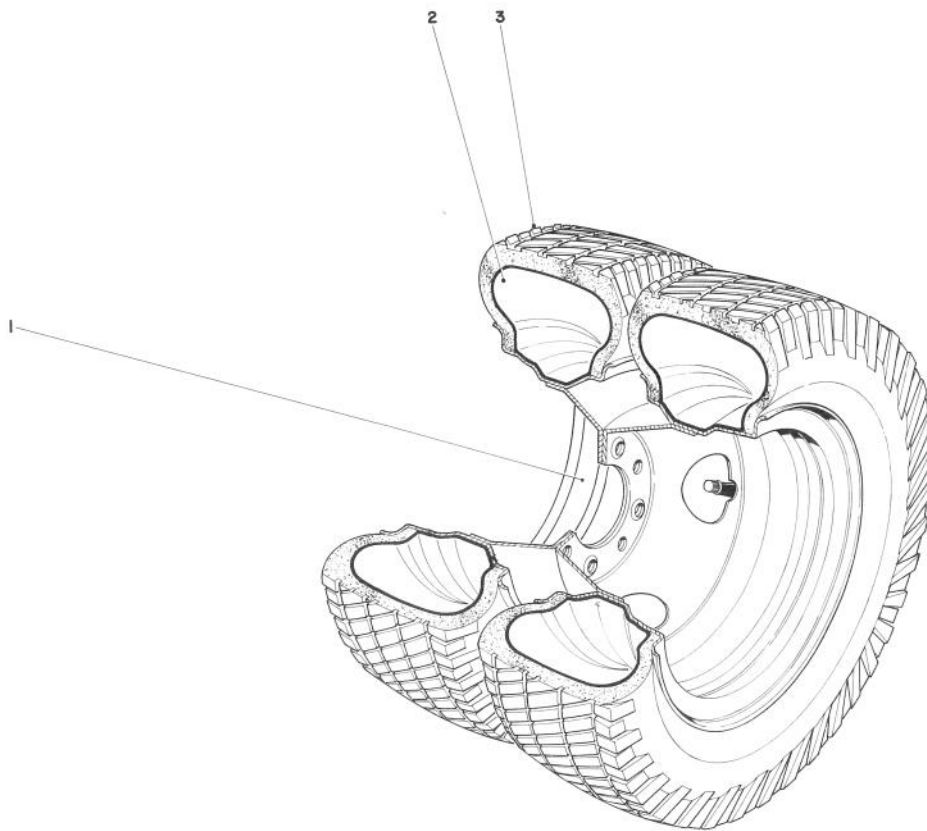

### REAR TIRES AND RIMS 8.00 X 16 FIELD INSTALLED KIT NO. 70200

Ref. No.	Part No.	Description	No. Used
1	37-4320	Wheel Assembly	4
2	28-9650	Inner Tube	4

Ref. No.	Part No.	Description	No. Used
3	28-9640	Tire Traction	4
*†	231-58	Rear Tire 9.50 x 16	4

\*Not Illustrated  
†Optional

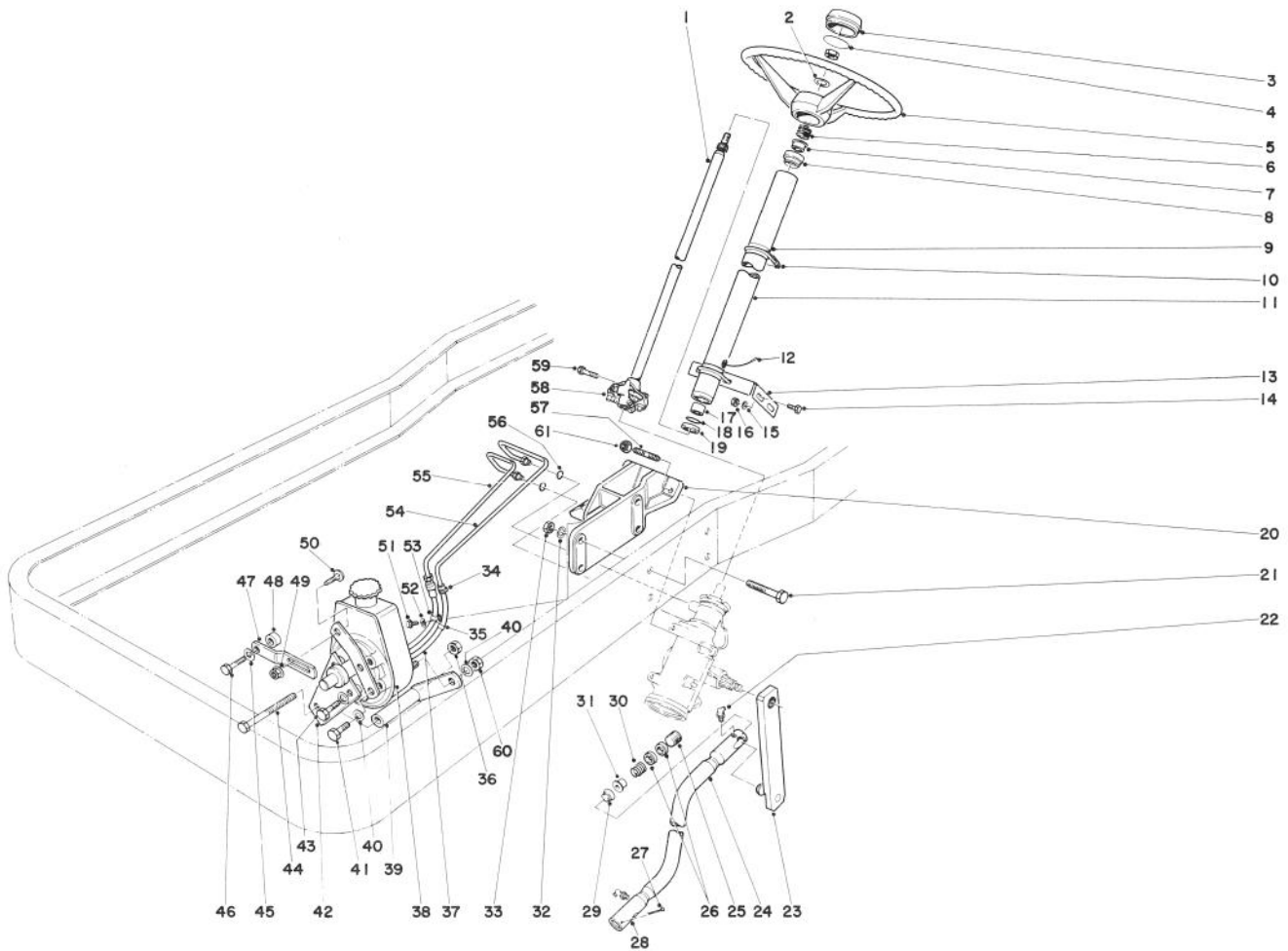

## STEERING ASSEMBLY

Ref. No.	Part No.	Description	No. Used
1	18-3090	Steering Shaft Assembly	1
2	18-3130	Washer	1
3	18-2140	Steering Wheel Cap	1
4	18-3170	Decal	1
5	18-2110	Steering Wheel	1
6	18-3120	Spring	1
7	18-3110	Spring Seat	1
8	18-3030	Bearing Assembly	1
9	18-1310	Saddle	4
10	18-2130	Clamp	2
11	18-3050	Steering Jacket Assembly	1
12	18-3040	Horn Cable Assembly	1
13	18-0830	Steering Column Support	1
14	322-2	Capscrew	2
15	3256-23	Flat Washer	2
16	32153-3	Locknut	2
17	18-3060	Bushing	1
18	18-3080	Seal	1
19	18-3070	Bearing Seal Retainer	1
20	57-5780	Engine & Power Steering Mount	1
21	327-10	Capscrew	4
22	302-33	Grease Fitting	2
23	18-2070	Pitman Arm	1
24	18-0330	Drag Link Tube	1
25	2116-5	End Plug	2
26	2116-6	Spherical Seat	4
27	3272-15	Cotter Pin	2
28	18-0320	Drag Link (Incl. Ref. #22, 24-26 & 29-31)	1
29	2116-8	Inner Plug	2
30	2116-7	Spring	2
31	2116-11	Spring Seat	2

Ref. No.	Part No.	Description	No. Used
32	3253-8	Lockwasher	4
33	3217-11	Nut	4
34	2412-36	Hose Clamp	2
35	2412-41	Clamp	1
36	32153-2	Locknut	1
37	18-2080	Return Hose	1
38	44-7800	Power Steering Pump	1
39	38-1770	Rear Support Power Steering Pump	1
40	21-0370	Lockwasher	7
41	39-7540	Capscrew	2
42	38-1800	Mtg. Plate—Power Steering Pump	1
43	39-7550	Capscrew	2
44	323-23	Capscrew	2
45	3253-6	Lockwasher	1
46	324-6	Capscrew	1
47	18-1380	Adjustment Bracket — Power Steering Pump	1
48	38-1850	Spacer — Adjustment Bracket	1
49	32128-19	Flange Nut	1
50	3231-2	Carriage Bolt	1
51	32104-6	Self-Tapping Screw	1
52	3256-24	Washer	1
53	2412-4	Clamp	1
54	39-7350	Return Tube	1
55	39-7340	Pressure Tube & Hose Assy	1
56	39-7310	O-Ring Seal	3
57	57-5760	Stud Steering Gear	3
58	18-3010	Flange Assembly	1
59	18-3100	Bolt	1
60	21-0360	Nut	1
61	3296-7	Locknut	3

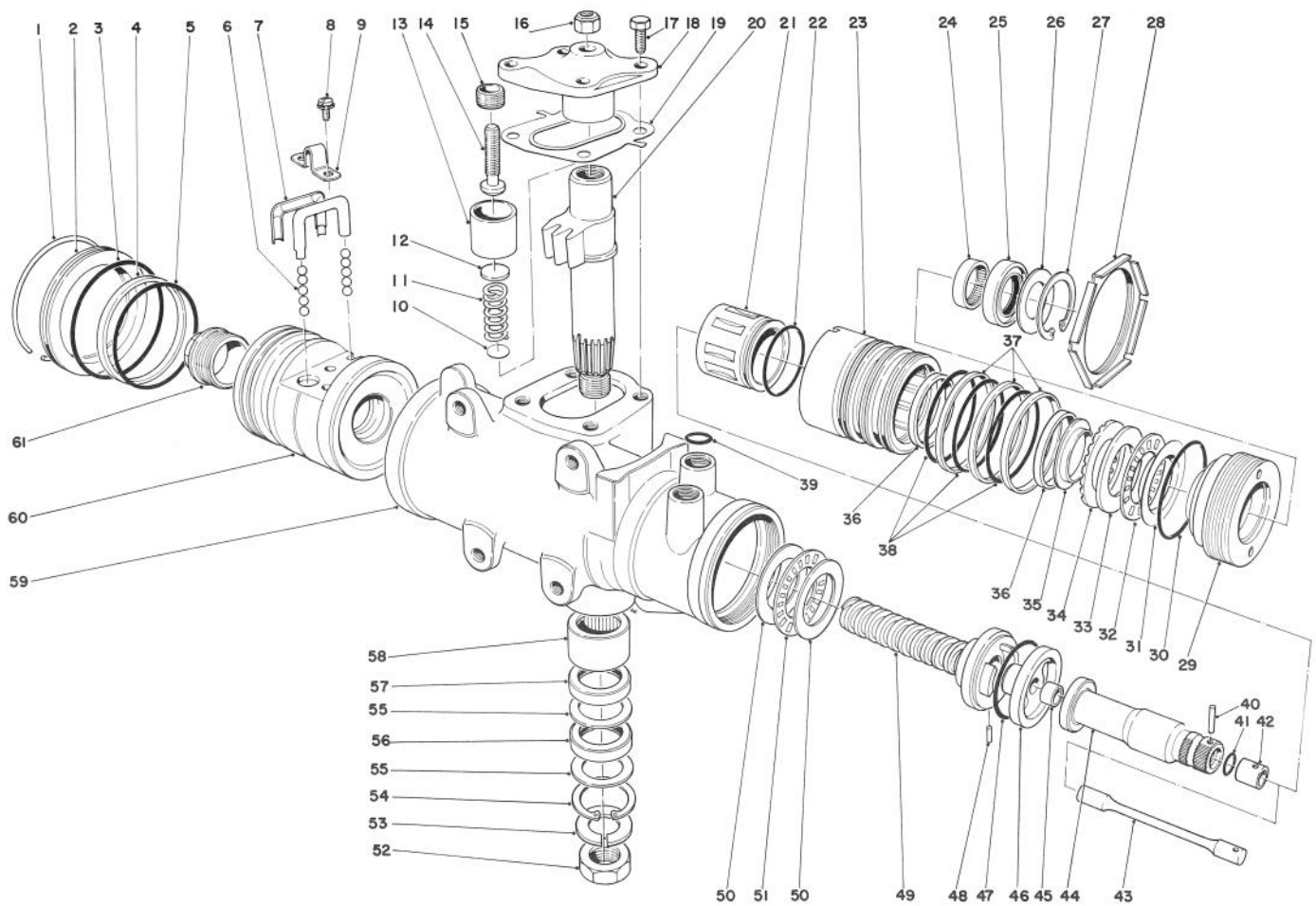

## STEERING GEAR 39-7330

Ref. No.	Part No.	Description	No. Used
1		Ring, Retaining	1
2	18-4330	Plug, Housing End	1
3		Seal, Housing End Plug	1
4		Ring, Rack Piston	1
5		Seal, O-Ring, Rack Piston	1
6		Ball, Chrome Alloy (.2812 Dia.)	11
*		Ball, (.2806 Dia.)	11
7	18-4280	Guide Ball Return	2
8	18-4260	Screw & Lockwasher Assembly	2
9	18-4270	Clamp, Ball Return Guide	1
10		Washer, Lash Adjuster Wear	1
11		Spring, Adjuster	1
12		Washer, Lash Adjuster	1
13		Bushing, Side Cover	1
14		Adjuster, Lash	1
15		Retainer, Lash Adjuster	1
16	28-8220	Nut, Lash Adjuster	1
17	28-8210	Bolt, Flange Hex Hd.	4
18		Cover, Housing Side (Incl. Ref. #13)	1
19	18-4180	Self - Assembly Gasket	1
20		Gear Pitman Shaft	1
21		Spool Valve	1
22	39-7430	Seal, O-Ring, Spool Valve	1
23		Valve Body	1
24	18-4240	Bearing Assembly, Needle	1
25		Seal, Stub Shaft	1

Ref. No.	Part No.	Description	No. Used
26		Seal, Stub Shaft Dust	1
27		Ring Retaining	1
28	18-4320	Nut, Adjuster Plug Lock	1
29		Plug Adjuster	1
30	28-8200	Seal, O-Ring	1
31		Race, Upper Thrust Bearing	1
32		Bearing Assembly Roller Thrust	1
33		Race, Thrust Bearing	1
34		Spacer, Thrust Bearing	1
35		Retainer, Bearing	1
36		Sleeve, Valve Body	2
37		Ring, Valve Body	3
38		Seal O-Ring	3
39	39-7310	O-Ring Seal	3
40		Pin, Torsion Bar	1
41		Seal O-Ring	1
42		Sleeve, Torsion Bar	1
43		Torsion Bar	1
44		Shaft, Stub	1
45		Bushing Torsion Bar	1
46		Cap Valve Body	1
47		Seal O-Ring	1
48		Pin Dowel	1
49		Worm, Steering	1
50		Race Thrust Bearing	2
51		Bearing Assembly, Roller Thrust	1
52	39-7440	Nut, Pitman, Arm	1

\*Not Illustrated

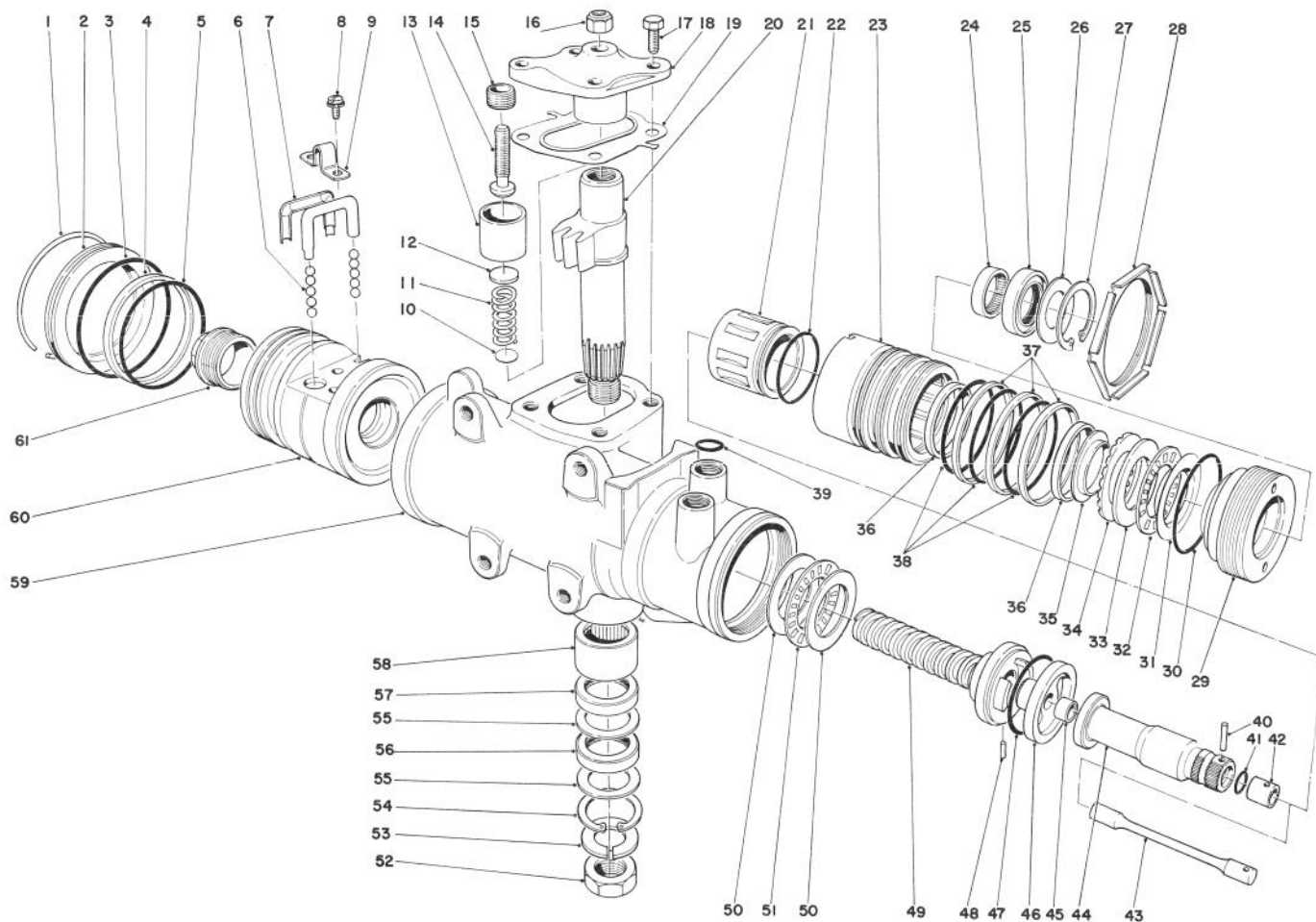

## STEERING GEAR 39-7330 (Continued)

Ref. No.	Part No.	Description	No. Used
53	39-7420	Lockwasher	1
54		Ring, Retaining	1
55		Washer, Seal Back Up	2
56		Seal, Pitman Shaft	1
57		Seal, Pitman Shaft	1
58	18-4200	Bearing, Pitman Shaft	1
59		Housing, Steering Gear	1
60		Nut, Rack Piston	1
61	18-4340	Plug, Rack Piston End	1
*	28-8230	Bearing Service Kit - Upper Thrust (Incl. Items 31-35)	1
*	18-5150	Seal Service Kit - Adjustment Plug (Incl. Items 25-27 & 30)	1
*	18-5160	Seal Service Kit - Pitman Shaft (Incl. Items 17, 54-57)	1
*	18-5170	Seal Service Kit - Valve Ring (Incl. Items 22, 37-38 & 47)	1
*	18-5180	Bearing Service Kit - Lower Thrust (Incl. Items 50-51)	1
*	18-5190	Ball Service Kit, Recirculating (Incl. Item #6)	1

Ref. No.	Part No.	Description	No. Used
*	43-7660	Cover Service Assy., Housing Side (Incl. Ref. #16-19)	1
*	28-8270	Seal Service Kit, End Plug (Incl. 1 & 3)	1
*	39-7410	Steering Gear Housing Assembly (Incl. Items 54-59)	1
*	18-4230	Plug Service Assembly Adjuster (Incl. Items 24-27 & 29-35)	1
*	28-8290	Seal Service Kit (Rack-Piston) (Incl. Items 4 & 5)	1
*	28-8250	Pitman Shaft, Gear Service Assembly (Incl. 12, 14-15 & 20)	1
*	39-7330	Steering Gear Complete	1
*	18-4310	Valve Assy. Hyd. Gear (Incl. Ref. #21-23, 36-38 & 40-48)	1
*	18-4250	Rack/Piston/Nut Assy. Worm & Pin (Incl. Ref. #4-9, 48, 49 & 60)	1

\*Not illustrated



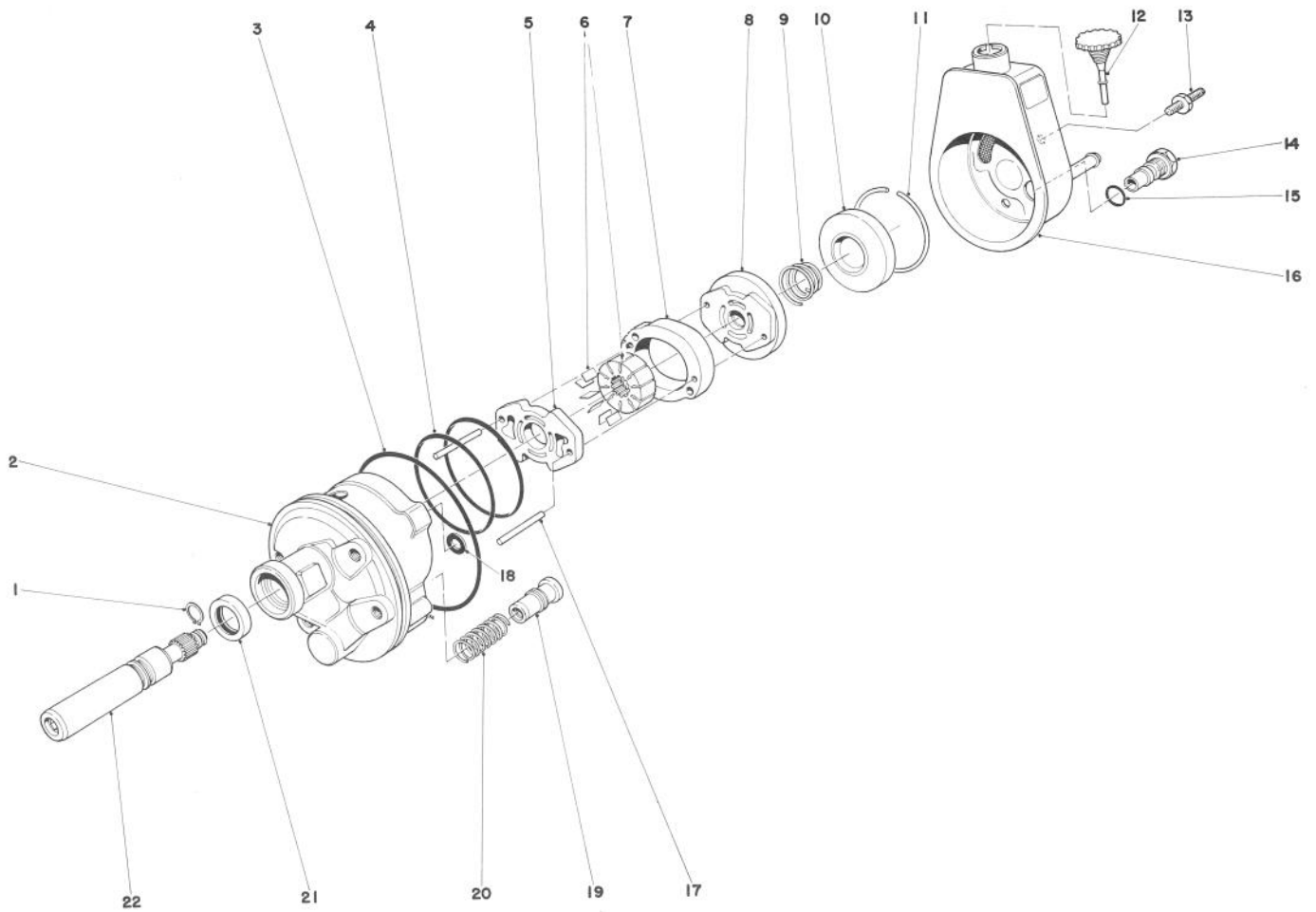

## PUMP POWER STEERING NO. 44-7800

Ref. No.	Part No.	Description	No. Used
1	44-7850	Ring, Shaft Retaining	1
2†		Housing Hydraulic Pump	1
3	37-8360	Seal O-Ring	1
4		Seal O-Ring	2
5	44-7840	Thrust Plate	1
6	44-7810	Ring Service Kit Rotor Vane (Incl. Ref. #1 & 7)	1
7	37-8350	Pump Ring	1
8	44-7830	Pressure Plate	1
9	44-7820	Spring Pressure Plate	1
10	37-8380	End Plate	1
11	37-8440	Ring Retaining	1
12	37-8420	Cap Assembly Reservoir	1
13	39-8700	Stud Pump Mounting	2
14	39-8680	Fitting Assy. (Incl. Ref. #15)	1

Ref. No.	Part No.	Description	No. Used
15	39-8710	Seal O-Ring	1
13	37-8400	Reservoir Service Kit Hyd. Pump (Incl. Ref. #3 & 18)	1
17	37-8300	Pin Pump Ring Dowel	2
18		Seal	1
19	37-8410	Valve Assembly Control	1
20	37-8450	Spring Flow Control	1
21	37-8340	Seal, Drive Shaft	1
22	44-2680	Shaft Service Ret. & Dr. (Incl. Ref. #1)	1
*	37-8460	Seal Service Kit (Incl. Ref. #3, 4, 15, 18 & 21)	1
*	44-7800	Power Steering Pump Complete	1
*	44-7860	Retaining Ring Service Kit (Incl. Ref. #1)	1

\*Not Illustrated

†Part only available by ordering 44-7800 Power Steering Pump

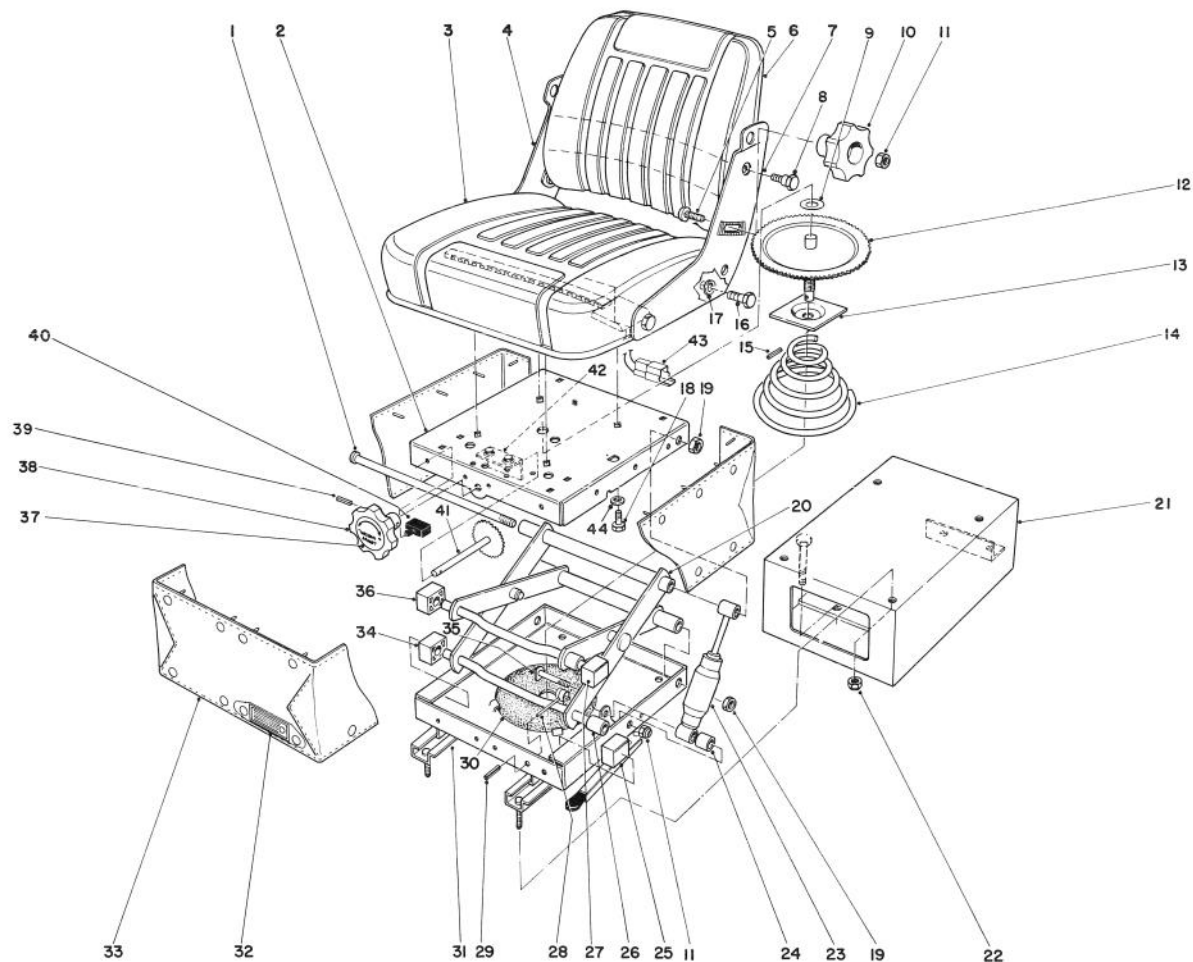

## SEAT ASSEMBLY (60-9070) AND SUSPENSION ASSEMBLY (46-3430)

Ref. No.	Part No.	Description	No. Used
1	44-8470	Shaft Bearing	2
2	37-0690	Upper Housing Assembly	1
3	37-0600	Seat Cushion Assembly	1
4	60-9080	Bracket, R.H. Side	1
5	46-3410	Bolt — Carriage	2
6	44-8440	Backrest Cushion	1
7	60-9090	Bracket, L.H. Side	1
8	60-9180	Bolt, Shoulder	2
9	37-0740	Thrust Washer	1
10	44-8450	Knob — Tilt Adjustment	2
11	32153-2	Nut — Lock	6
12	37-0840	Gear Assembly	1
13	37-0830	Washer Assembly	1
14	37-0820	Spring	1
15	32121-45	Pin — Roll	1
16		Bolt 1/2-13 UNC x 1.50	4
17	60-9170	Spacer	4
18	323-4	Capscrew	4
19	3296-45	Nut Lock	2
20	46-3420	Suspension Arm Assembly	1
21	36-9630	Seat Base	1
22	32153-3	Nut — Lock	4
23	37-0660	Shock Absorber	1

Ref. No.	Part No.	Description	No. Used
24	37-0670	Bearing	2
25	37-0650	Slides Block — Lower L.H.	1
26	37-0880	Bearing	4
27	37-0640	Slides Block — Upper L.H.	1
28	37-0780	Ride Indicator	1
29	32121-24	Roll — Pin	1
30	37-0810	Pad	1
31	46-3400	Suspension Base Assembly	1
32	37-0770	Decal — Ride Instructions	1
33	37-0760	Boot Assembly	1
34	37-0630	Slides Block — Lower R.H.	1
35	37-0680	Bolt — Shoulder	1
36	37-0620	Slides Block — Upper R.H.	1
37	37-0750	Decal, Weight	1
38	37-0730	Knob — Weight Adjustment	1
39		Pir. — Spiral	1
40	37-0700	Bumper	2
41	37-0850	Gear & Shaft Assembly	1
42	37-0860	Bracket, Seat	1
43	33-0730	Switch, Seat	1
		Used on HTM 175 Only	
44	3256-24	Washer	4
		Not Used on HTM 175	

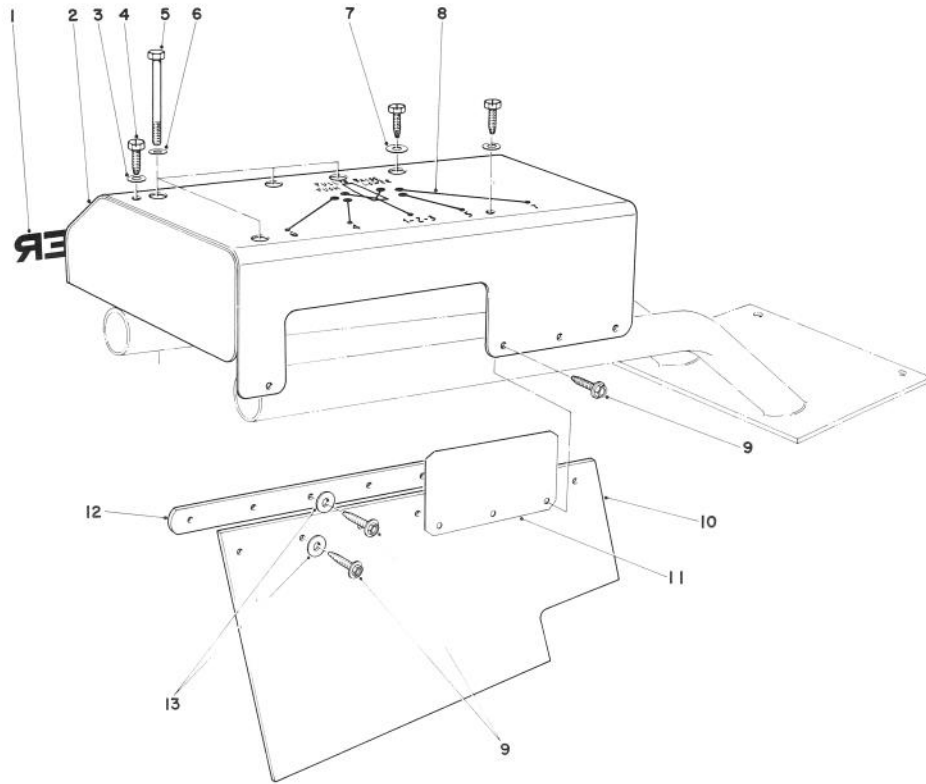

## VALVE COVER AND SHIELD ASSEMBLY

Ref. No.	Part No.	Description	No. Used
1	19-2270	Decal	1
2	28-8960	Valve Cover	1
3	3256-24	Washer	2
4	32104-6	Screw Self Tapping	3
5	322-38	Capscrew	3
6	3256-23	Washer	3
7	3256-4	Washer	1

Ref. No.	Part No.	Description	No. Used
8	5-8080	Decal	1
9	12-3270	Screw Special	7
10	28-8980	Flap	1
11	28-9000	Closure Cover	1
12	28-8990	Strap Support	1
13	3256-22	Washer	2

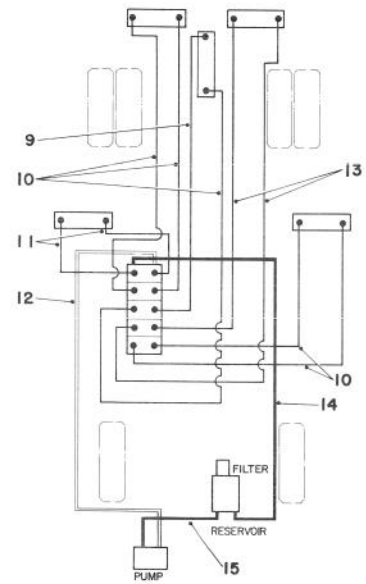
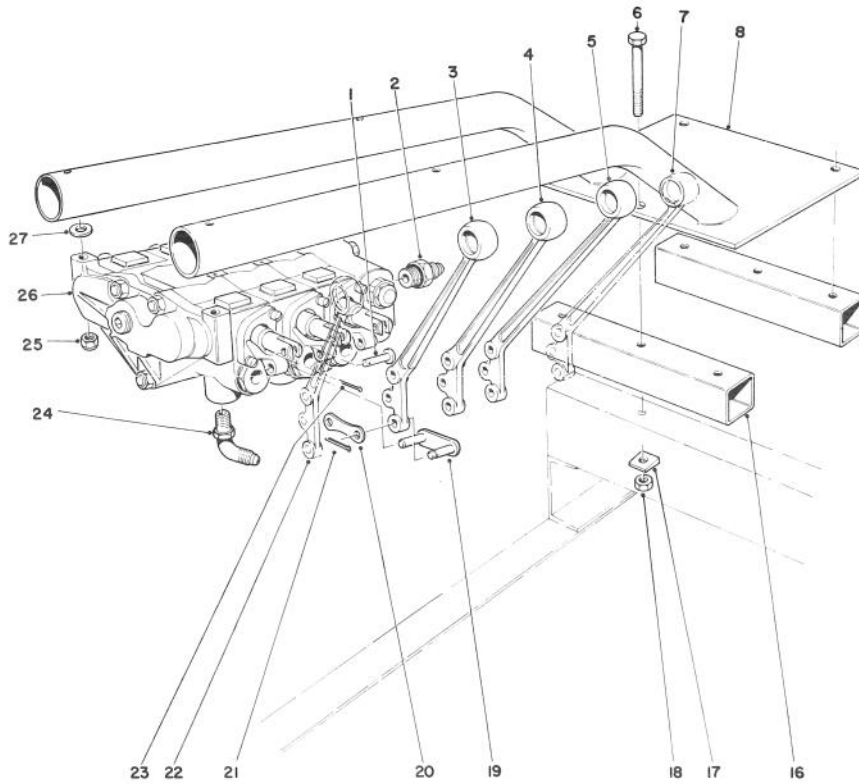

## VALVE BANK & HOSES

Ref. No.	Part No.	Description	No. Used
1	353-322	Pin	5
2	353-433	Straight Swivel — Female	2
3	5-7840	Modified Lever	1
4	353-323	Lever	1
5	5-7830	Modified Lever	1
6	325-13	Capscrew	3
7	5-7860	Modified Lever	1
8	28-9030	Valve Stand	1
9	26-8520	Hydraulic Hose	1
10	5-0200	Hydraulic Hose (77")	5
11	5-0220	Hydraulic Hose (46")	2
12	36-2480	High Pressure Hose (94")	1
13	5-0230	Hydraulic Hose (102")	2
14	28-9010	Hose Return (62")	1
15	18-2350	Suction Hose	1

Ref. No.	Part No.	Description	No. Used
16	3-0166	Spacer Tube	2
17	3290-216	Bevel Washer	3
18	32153-5	Locknut	3
19		Handle — Link	5
20		Plate — Link	5
21		Pin — Cotter	10
22	5-7850	Modified Lever	1
23	353-321	Cotter Pin	5
24	353-212	Male Elbow	10
25	3296-29	Locknut	3
26	44-7701	Hydraulic Control Valve Complete	1
27	3256-23	Washer	3
*	63-8760	Link Pin Kit (Incl. Ref. #19-21)	1

\*Not Illustrated

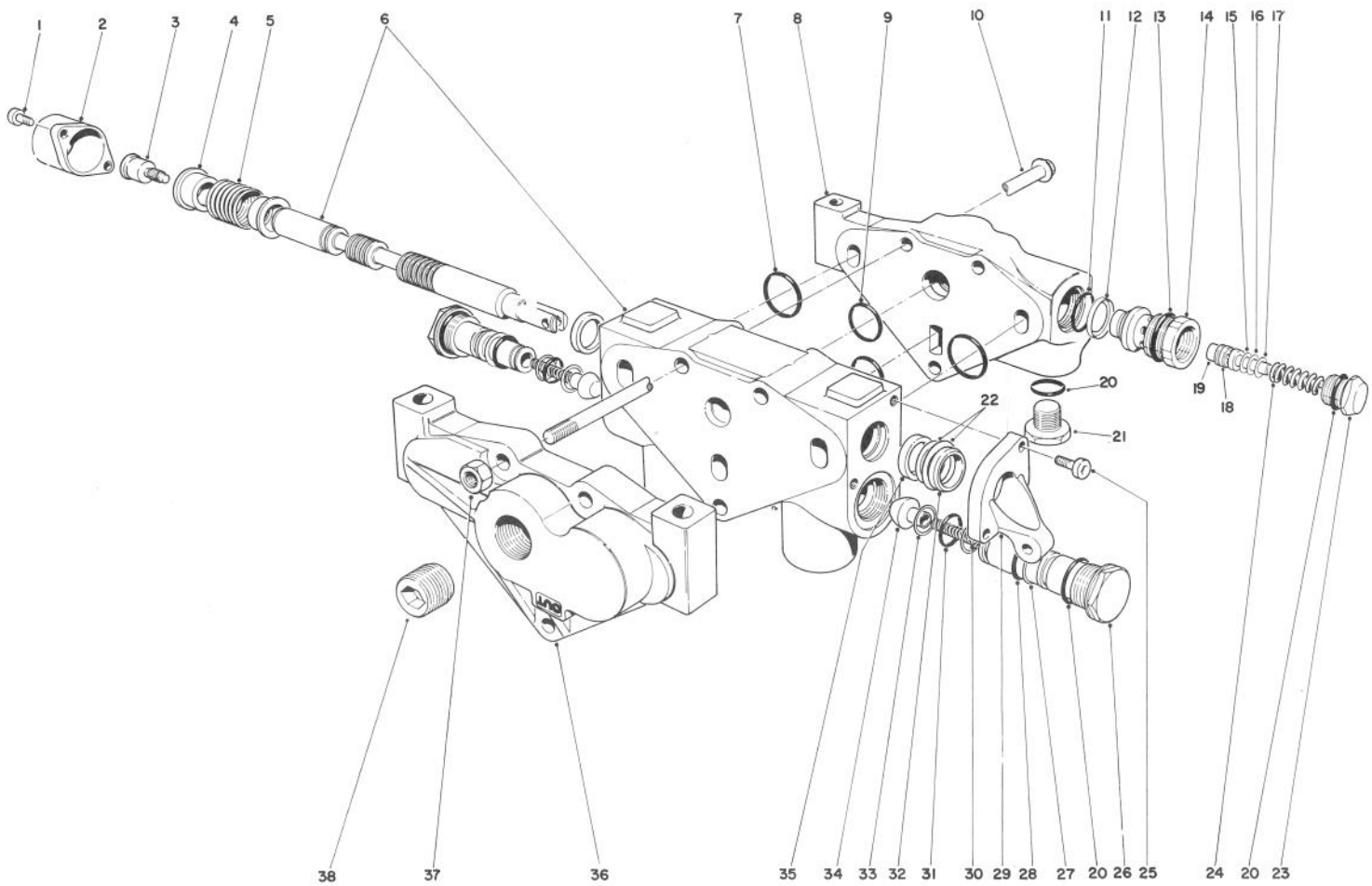

## HYDRAULIC VALVE ASSEMBLY NO. 44-7701

Ref. No.	Part No.	Description	No. Used
1	52-5890	Screw – Hex Socket Hd.	10
2	52-5870	Bonnet	5
3	52-5860	Spool Collar	5
4	353-417	Stop Collar	10
5	44-7650	Spring	5
6		Housing & Spool Assy.	5
7		Section Seal, Return	12
8	44-7621	End Cover	1
9		Sect. Seal, Pressure	12
10	44-7612	Bolt Hex Washer Hd.	3
11	353-758	O-Ring	1
12	353-759	Seal, Back Up	1
13	353-331	O-Ring Seal	1
14	353-760	Rel. Body	1
15	353-328	Shim (.040)	1
16	353-329	Shim (.020)	1
17	353-330	Shim (.010)	1
18	353-392	Seal Relief Poppet	1
19	353-531	Poppet Relief Assembly	1
20	237-80	O-Ring Seal	12
21	353-721	Plug	2
22	353-515	Seal Kit (Incl. Ref. #33)	10

Ref. No.	Part No.	Description	No. Used
23	353-334	Cap, Relief Valve	1
24	46-2370	Spring	1
25	52-5900	Screw – Hex Socket Hd.	10
26	44-7660	Lift Check Plug	10
27	353-306	Back-Up Washer Cover	10
28	353-305	O-Ring Check	10
29	353-324	Handle Bracket	5
30	353-304	Lift Check Spring	10
31	353-302	O-Ring, Check Plug Seal (Inner)	10
32	353-318	Secondary Spool Wiper Seal	5
33	353-303	Back-Up Washer (Inner)	20
34	353-301	Lift Check Poppet	10
35	353-570	Spool Seal	10
36	353-554	End Cover	1
37	3219-3	Locknut	3
38	353-325	Plug	1
*	44-7680	Valve Section Complete (Incl. Ref. #1-6 & 26-35)	5
*	353-481	Plug Load Check (Incl. Ref. #26-28, 31 & 33)	10
*	353-743	Seal Kit (Incl. Ref. #28, 31 & 33)	1
*	353-835	Seals — Section Set (Incl. Ref. #7 & 9)	1

\*Not Illustrated

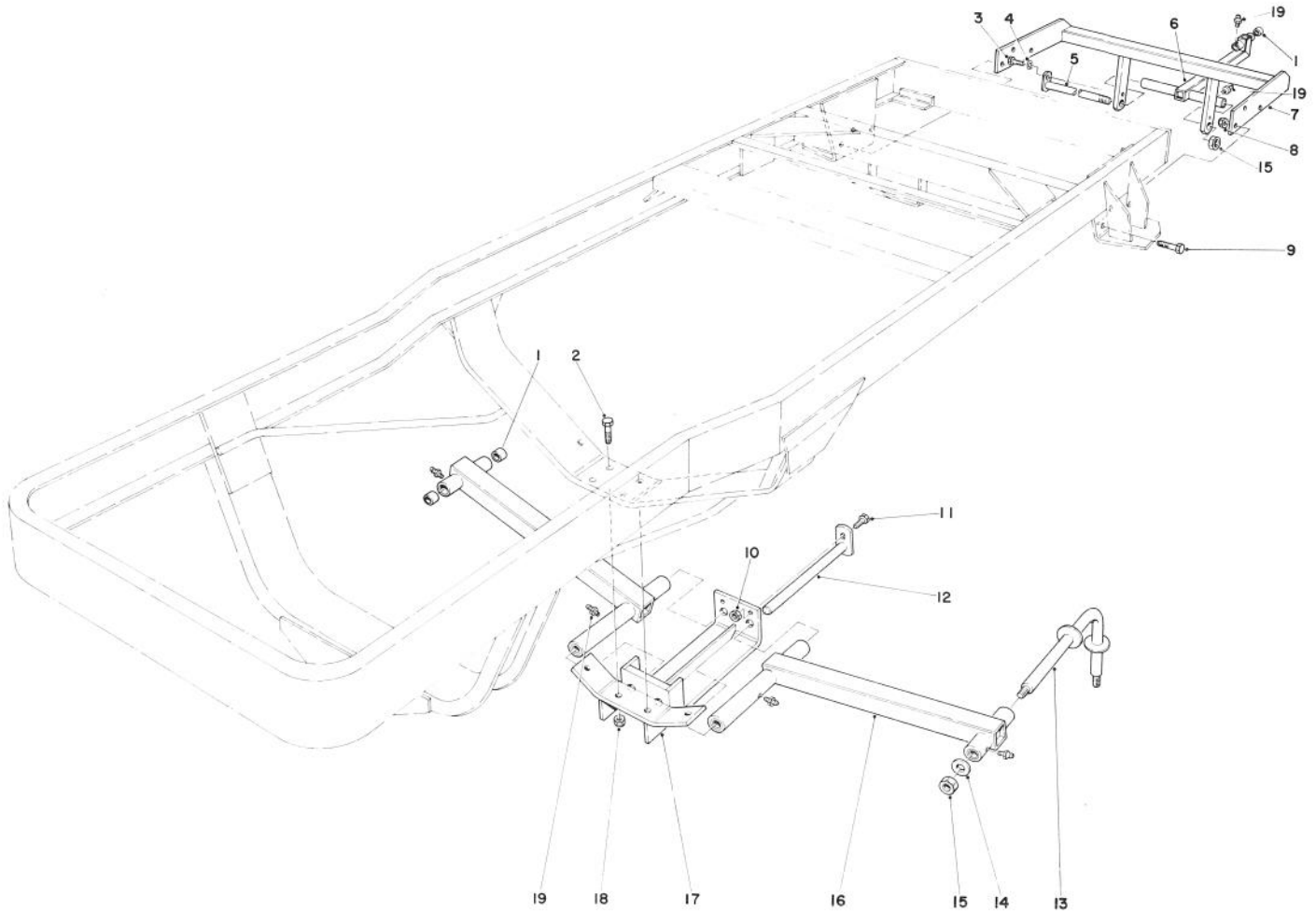

### DRAWBAR ASSEMBLY NO. 1,2 AND 3 POSITION

Ref. No.	Part No.	Description	No. Used
1	3-0348	Bushing	18
2	327-22	Capscrew	4
3	322-3	Capscrew	1
4	3253-4	Lockwasher	1
5	37-2760	Pin – Bail Lift	1
6	26-8390	Lift Arm	1
7	26-8270	Pivot Support	1
8	3296-51	Locknut	6
9	328-24	Capscrew	6
10	32153-3	Locknut	2

Ref. No.	Part No.	Description	No. Used
11	322-6	Capscrew	2
12	26-8250	Lift Arm Pin	2
13	26-8310	Lift Bail Pin	3
14	3-8448	Washer	3
15	32153-10	Locknut	4
16	26-8340	Lift Arm	2
17	26-8160	Lift Arm Support	1
18	3296-24	Locknut	4
19	302-5	Grease Fitting	6

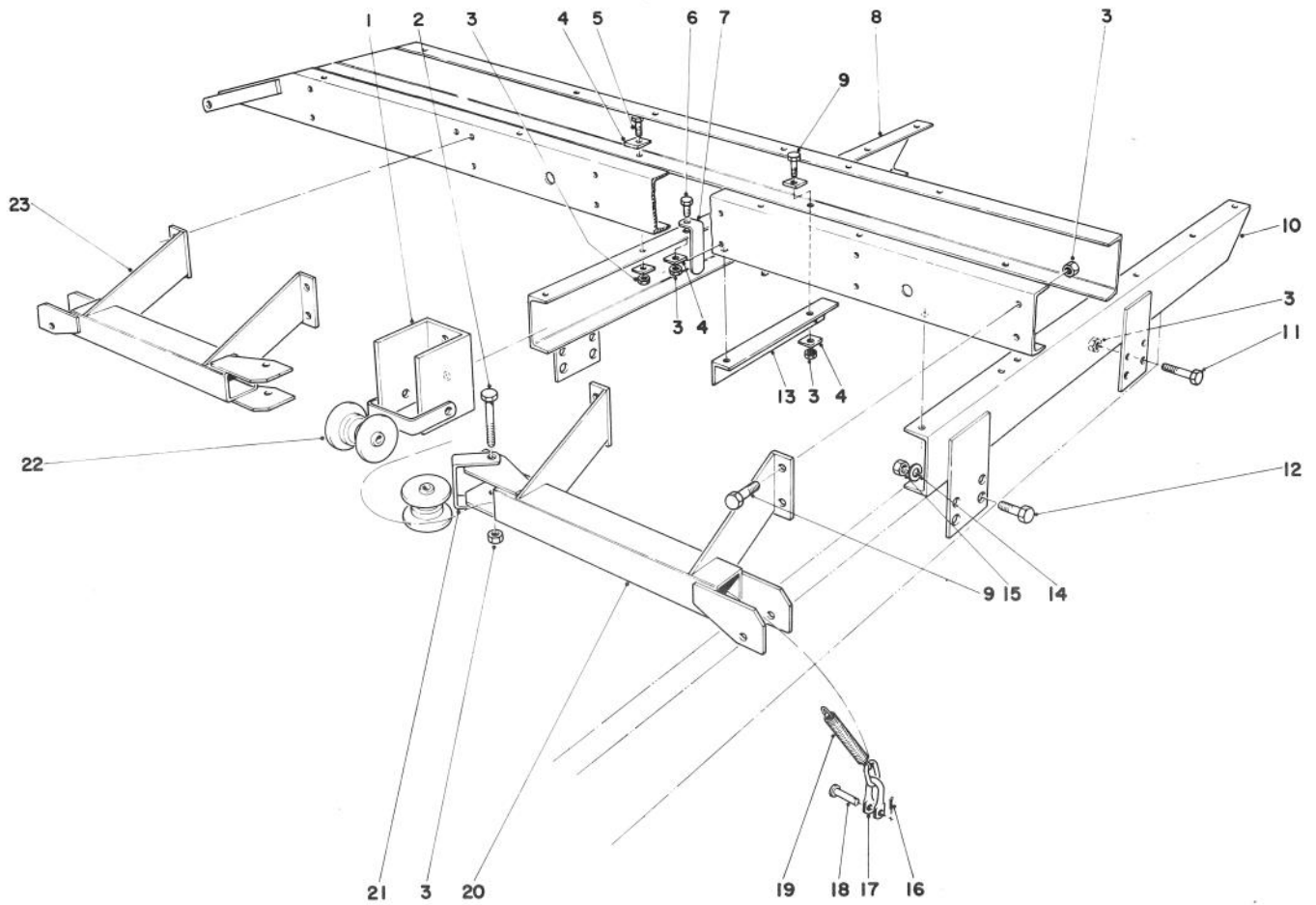

## MAIN FRAME ASSEMBLY – Front

Ref. No.	Part No.	Description	No. Used
1	3-0112	Sheave Bracket	1
2	325-18	Capscrew	5
3	32153-5	Locknut	25
4	3290-216	Washer	10
5	325-8	Capscrew	4
6	325-5	Capscrew	2
7	3-0236	Hose Clip	2
8	3-4608	Side Channel Right	1
9	325-6	Capscrew	10
10	3-4606	Side Channel Left	1
11	325-7	Capscrew	2
12	327-4	Capscrew	6

Ref. No.	Part No.	Description	No. Used
13	26-8580	Chain Support	1
14	3253-8	Lockwasher	6
15	3217-11	Nut	6
16	3272-10	Cotter Pin	2
17	5-2942	Shackle	2
18	283-10	Pin	2
19	5-1706	Spring	2
20	3-6690	Side Mower Tube L.H.	1
21	3-0136	Chain Keeper	5
22	3-2196	Sheave	5
23	3-6680	Side Mower Tube R.H.	1

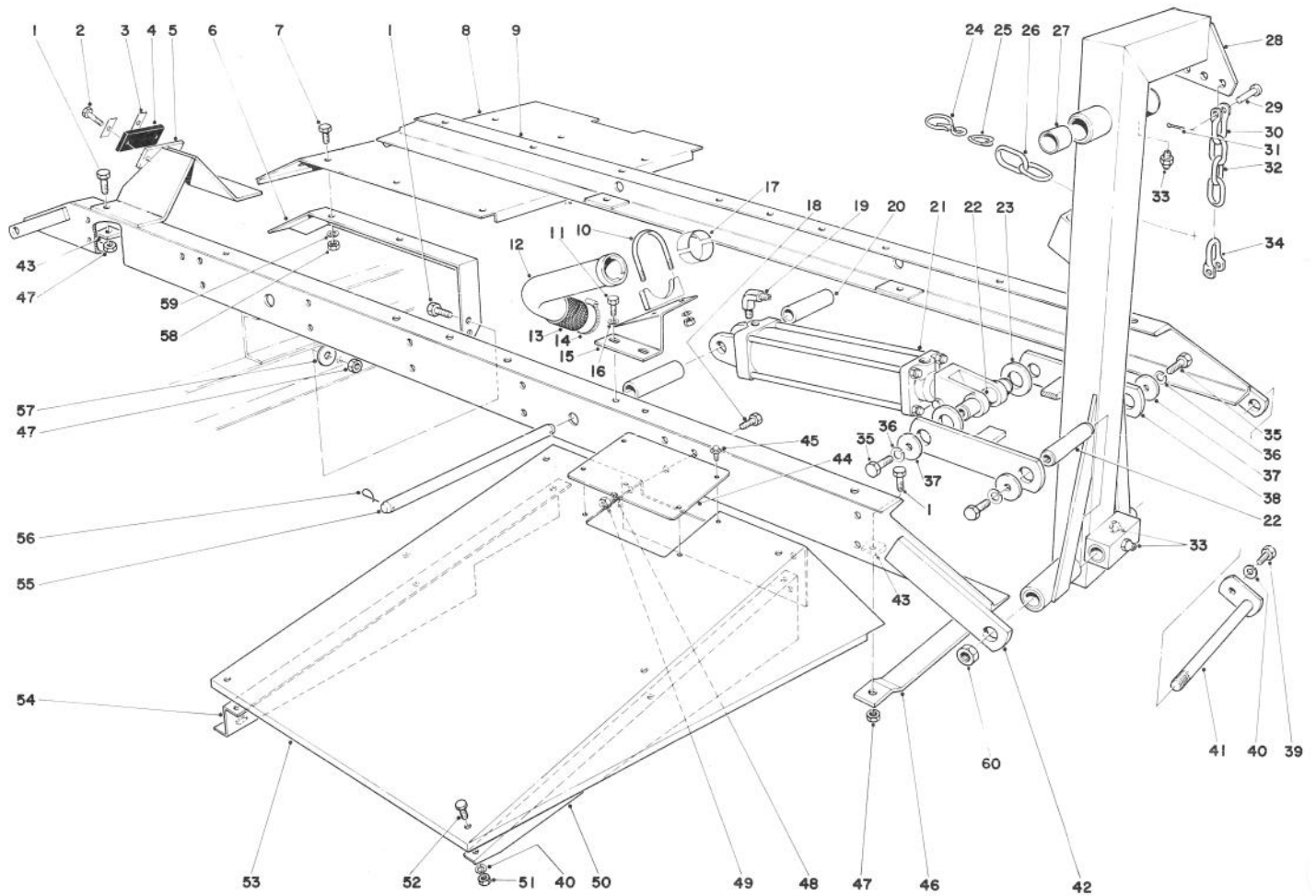

## MAIN FRAME ASSEMBLY — Front Center

Ref. No.	Part No.	Description	No. Used
1	325-6	Capscrew	10
2	3290-319	Machine Screw	4
3	11-5270	Washer Bumper	4
4	11-4590	Bumper Pad	2
5	11-5630	Stop Arm	2
6	3-6520	Bracket	4
7	325-3	Capscrew	16
8	3-4596	Mudguard R.H.	1
*	3-4597	Mudguard L.H.	1
9	37-2840	Front Cross Channel Rear	1
10	18-8590	Clamp	1
11	32104-6	Self-Tapping Screw	2
12	18-2410	Fill Tube	1
13	18-2790	Extension Hose	1
14	2412-42	Hose Clamp	2
15	18-2420	Fill Tube Bracket	1
16	3256-24	Washer	2
17	18-8600	Saddle	2
18	323-6	Capscrew	6
19	5-6560	Elbow (78)	4
20	20-4390	Tube Spacer	4
21	22-7530	Cylinder 12"	2
22	3-0128	Shaft	4

Ref. No.	Part No.	Description	No. Used
23	3256-62	Washer	4
24	286-3	Snap Hook	4
25	287-2	Cold Shut	4
26	3-1365	Safety Chain (15 Links)	2
27	3-0348	Bushing	16
28	37-2800	Lift Arm L.H. No. 6 (Incl. Ref. #27)	1
*	37-2810	Lift Arm R.H. No. 7 (Incl. Ref. #27)	1
29	283-10	Pin	4
30	5-2942	Shackle	2
31	3272-10	Cotter Pin	4
32	3-4636	Lift Chain (7 Links)	2
33	302-5	Grease Fitting	6
34	8-0280	Shackle	2
35	3211-4	Screw	8
36	3253-5	Lockwasher	8
37	5-1720	Washer	8
38	23-2610	Link	2
39	322-3	Capscrew	2
40	3253-4	Lockwasher	14
41	37-2760	Bail Lift Pin	2
42	37-2860	Front Cross Channel Front	1

\*Not Illustrated



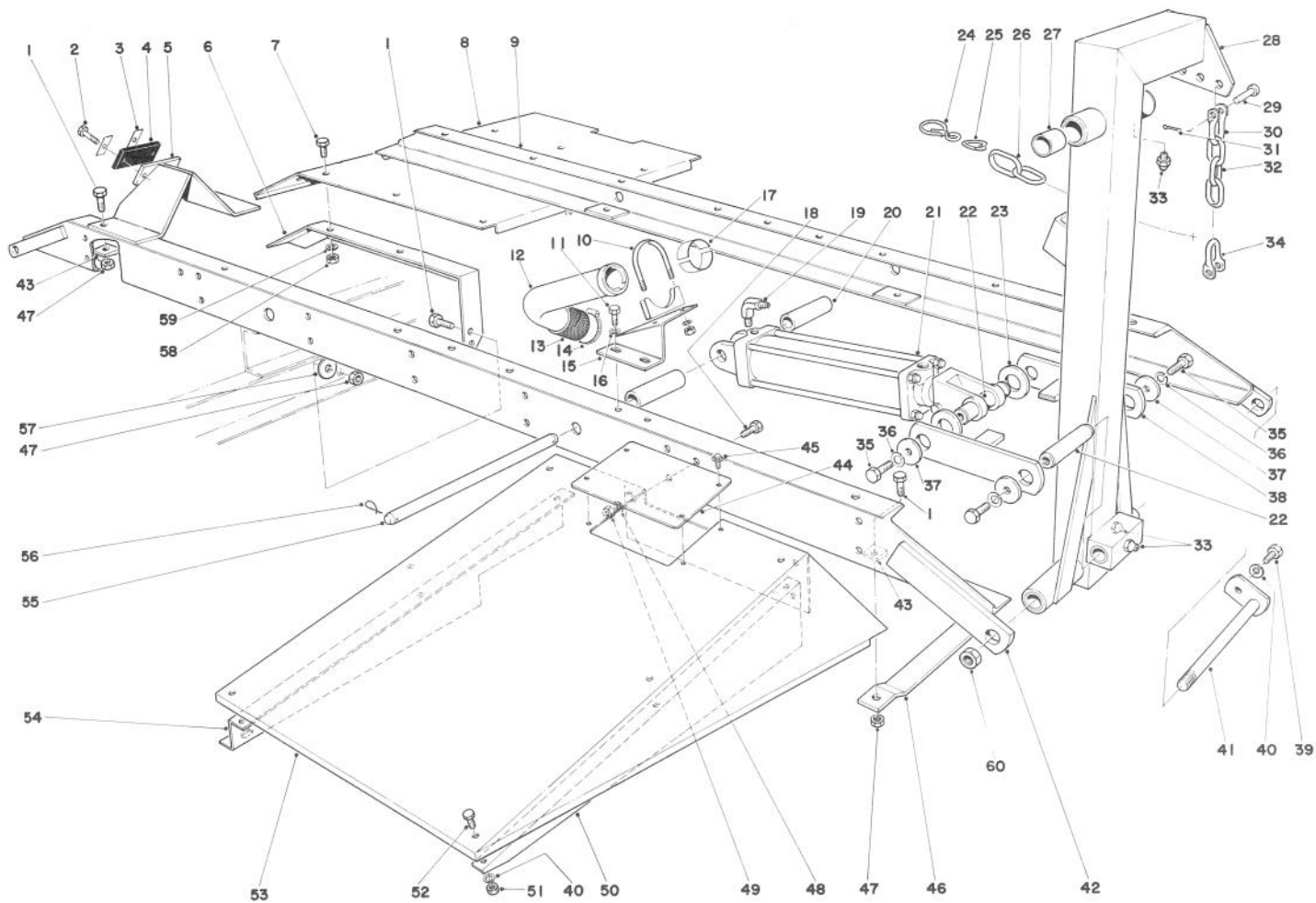

## MAIN FRAME ASSEMBLY — Front Center (Continued)

Ref. No.	Part No.	Description	No. Used
43	3290-216	Bevel Washer	8
44	21-5610	Cover	2
45	32104-76	Self-Tapping Screw	8
46	37-2910	Cylinder Rest	2
47	32153-5	Locknut	10
48	3253-21	Lockwasher	6
49	3217-7	Nut	6
50	5-2262	Fender Brace	2
51	3217-6	Nut	12
52	322-2	Capscrew	12

Ref. No.	Part No.	Description	No. Used
53	21-5480	Fender L.H.	1
*	21-5490	Fender R.H.	1
54	5-2263	Fender Mount L.H.	1
*	5-2264	Fender Mount R.H.	1
55	3-0144	Shaft	2
56	5-3126	Spring Pin	4
57	3-1615	Spacer	2
58	3217-9	Nut	16
59	3253-7	Lockwasher	16
60	32153-10	Locknut	2

\*Not Illustrated

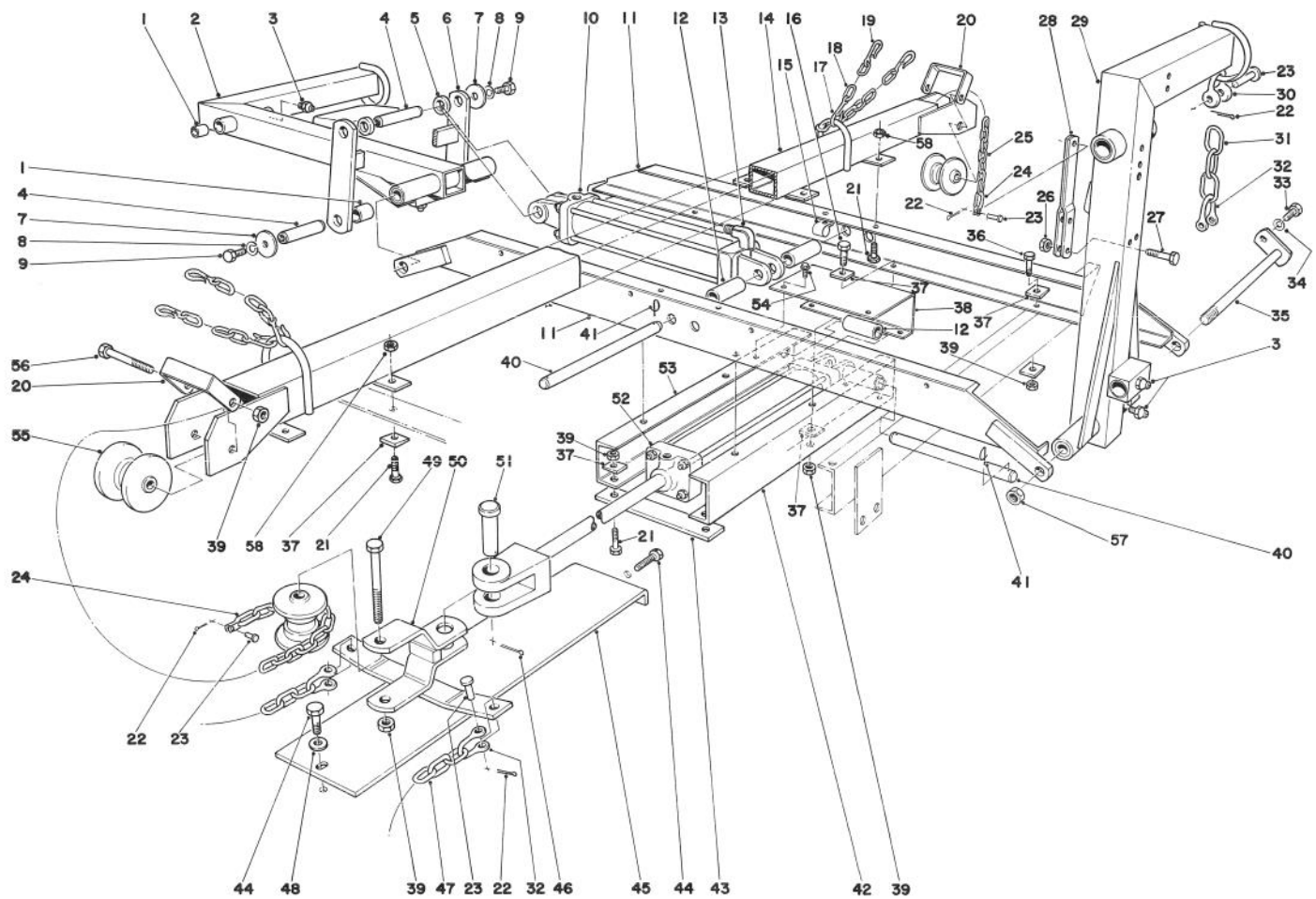

## MAIN FRAME ASSEMBLY — Rear

Ref. No.	Part No.	Description	No. Used
1	3-0348	Bushing	16
2	37-2890	Arm Short	1
3	302-5	Grease Fitting	6
4	3-0128	Shaft	4
5	3256-30	Washer	4
6	23-2610	Link	2
7	5-1720	Washer	8
8	3253-5	Lockwasher	8
9	3211-4	Capscrew	8
10	22-7520	Hydraulic Cylinder 10"	2
11	8-1280	Rear Cross Channel	2
12	20-4390	Tube Spacer	6
13	5-6560	Elbow	6
14	26-8460	Channel Brace	1
15	304-61	Hose Clamp	1
16	325-7	Capscrew	4
17	286-3	Safety Hook	4
18	287-2	Repair Link — Chain	4
19	3-1365	Chain	2
20	3-0136	Chain Keeper	2
21	325-6	Capscrew	10
22	3272-10	Cotter Pin	8
23	283-10	Pin	8

Ref. No.	Part No.	Description	No. Used
24	5-2942	Shackle	2
25	26-8540	Lift Chain	1
26	32153-2	Locknut	1
27	323-8	Capscrew	1
28	26-8370	Lift	1
29	37-2880	Arm Short	1
30	8-0280	Chain Shackle	2
31	3-4636	Chain Lift Bail	2
32	8-0280	Shackle	4
33	322-3	Capscrew	2
34	3253-4	Lockwasher	2
35	37-2760	Pin Bail Lift	2
36	325-8	Capscrew	4
37	3290-216	Washer	18
38	42-3550	Cover Cylinder Mount	1
39	32153-5	Locknut	10
40	3-0144	Shaft	3
41	5-3126	Pin Spring	6
42	26-8490	Channel L.H.	1
43	26-9690	Cylinder Rest	1
44	32104-6	Screw Self Tapping	2
45	18-2620	Plate	1
46	3272-13	Cotter Pin	1

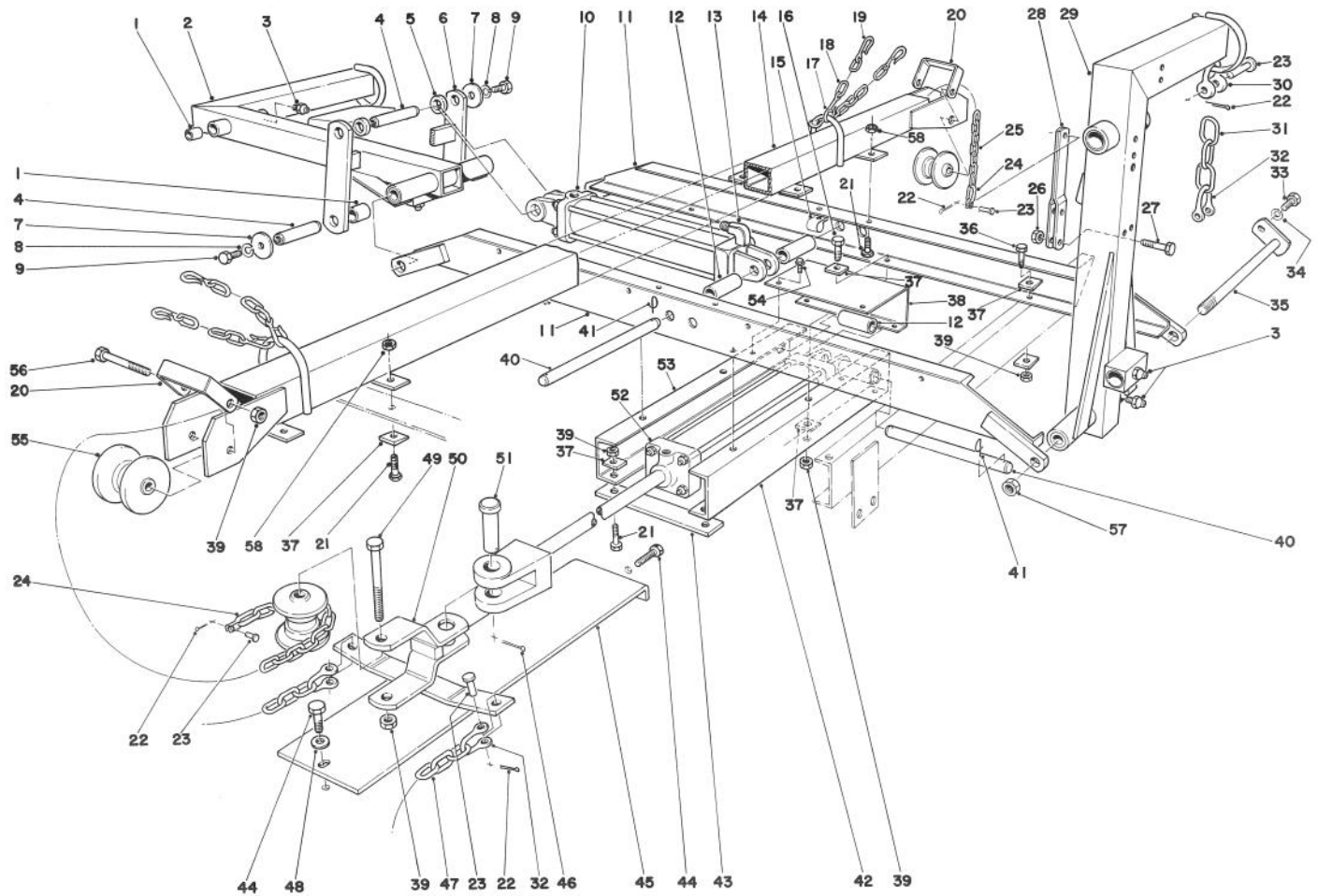

## MAIN FRAME ASSEMBLY — Rear (Continued)

Ref. No.	Part No.	Description	No. Used
47	26-8530	Lift Chain	2
48	3256-24	Flat Washer	1
49	325-14	Capscrew	1
50	26-8210	Pulley Support	1
51	26-8590	Pin Cylinder	1
52	22-7530	Cylinder 12"	1

Ref. No.	Part No.	Description	No. Used
53	37-2790	Channel R.H.	1
54	32104-17	Hex Hd. Self-Tapping Screw	4
55	3-2196	Sheave	3
56	325-18	Capscrew	2
57	32153-10	Locknut	2
58	32128-8	Nut	8

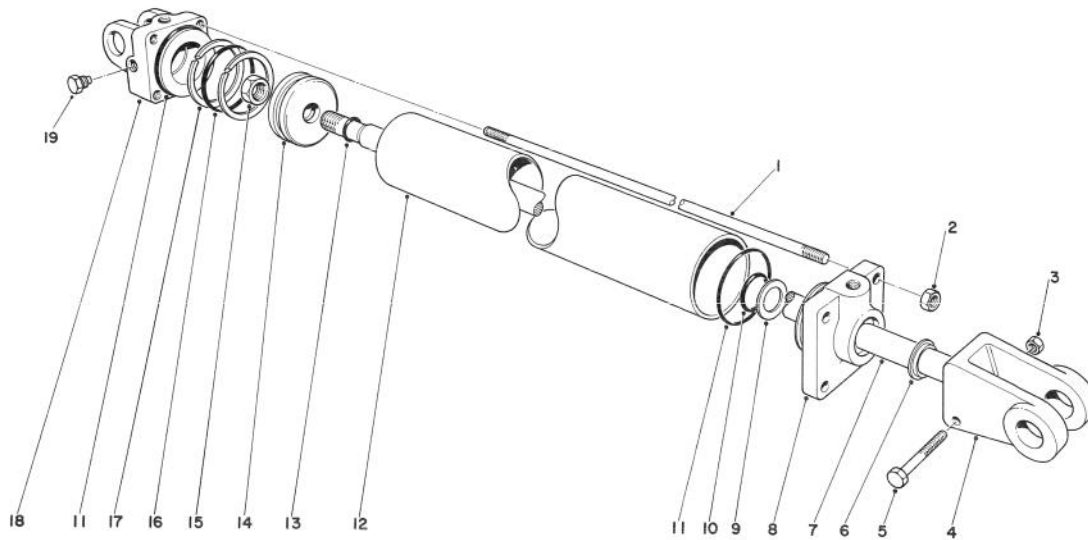

## 10" (22-7520) AND 12" (22-7530) CYLINDERS

Ref. No.	Part No.	Description	No. Used
1	22-8670	Tie Rod 10"	4
*	22-8710	Tie Rod 12"	4
2	3217-9	Nut	4
3	32153-3	Locknut	1
4	22-8680	Clevis Assembly	1
5	322-11	Capscrew	1
6	22-8660	Wiper Ring Seal	1
7	22-8610	Piston Rod 10"	1
*	22-8690	Piston Rod 12"	1
8	32153-3	Head	1
9	22-8650	Back-Up Washer	1
10	22-8640	"O" Ring Seal	1

Ref. No.	Part No.	Description	No. Used
11	22-8550	"O" Ring Seal	2
12	22-8620	Barrel 10"	1
*	22-8700	Barrel 12"	1
13	22-8600	"O" Ring Seal	1
14	22-8590	Piston	1
15	22-8560	Locknut	1
16	22-8570	"O" Ring Seal	1
17	22-8580	Back Up Washer	2
18	22-8540	Butt-End Cap	1
19	281-2	Plug — Pipe	1
*	22-8720	Seal Kit (Incl. Ref. #6, 9-11, 13 & 16-17)	1

\*Not Illustrated

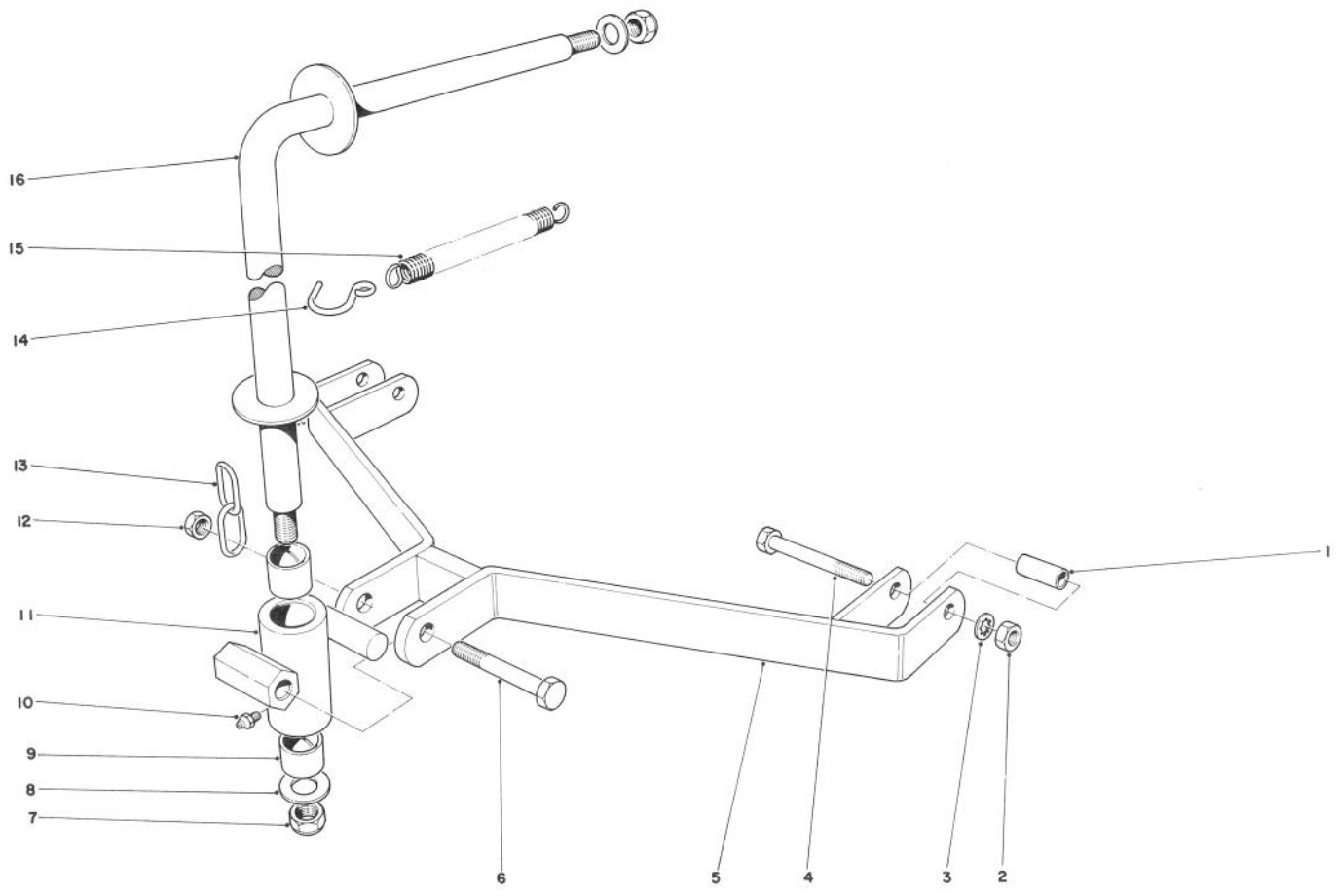

### DRAWBAR ASSEMBLY

Ref. No.	Part No.	Description	No. Used
1	5-1091	Spacer	14
2	3217-9	Nut	14
3	3254-4	Lockwasher	14
4	325-14	Capscrew	14
5	3-9280	Drawbar	7
6	325-17	Capscrew	7
7	32153-10	Locknut	14
8	3-8448	Washer	14
9	3-0348	Bushing	14

Ref. No.	Part No.	Description	No. Used
10	302-5	Grease Fitting	7
11	1-6559	Housing (Incl. Ref. #9-10)	7
12	32153-5	Locknut	7
13	3-0293	Chain	4
14	3-2198	S-Hook	5
15	5-1706	Spring	7
16	28-8720	Bail, Lift	4
*	26-8310	Bail, Lift 1, 2 & 3 Position	3

\*Not Illustrated

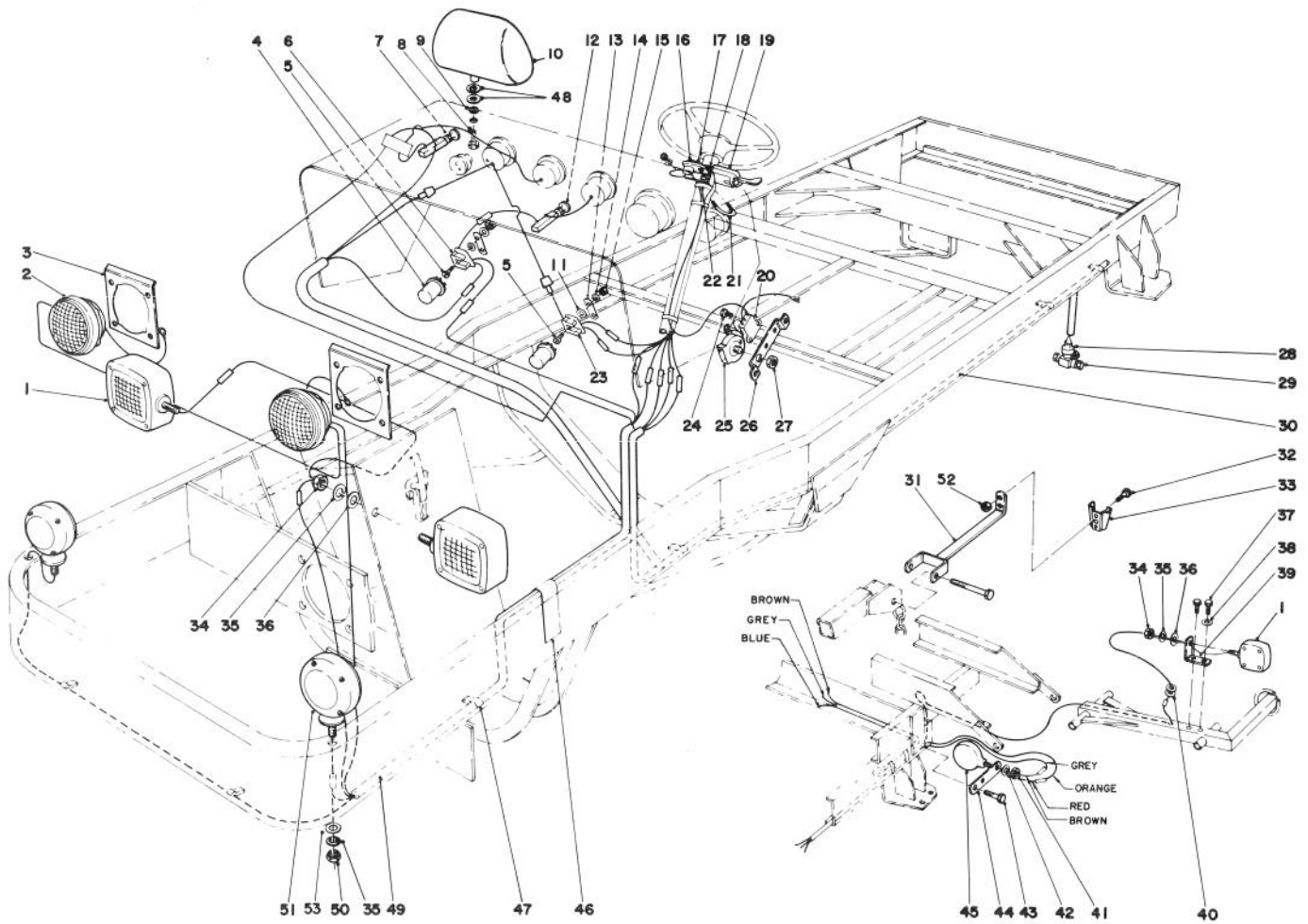

## LIGHT & ROAD KIT NO. 38-6310 (Optional)

Ref. No.	Part No.	Description	No. Used
1	38-6190	Signal Lamp (SMV) (Incl. Ref. #34-37)	4
2	7-1646	Headlight	2
3	18-1010	Headlight Holder	2
4	218-456	Flasher	2
5	3252-2	Screw	2
6	38-2110	Connector Assembly	1
7	218-213	Light Switch	1
8	321-3	Capscrew	1
9	3253-3	Washer — Lock	1
10	60-9430	Mirror	1
11	19-2430	Plastic Washer	2
12	38-2130	Switch Flasher	1
13	18-4370	Flasher Connector Bracket	2
14	3253-12	Lockwasher	2
15	3217-26	Nut	2
16	18-2830	Horn Button	1
17	18-2480	Throttle Lever Support	1
18	2412-3	Hose Clamp	1
19	60-9390	Signal Controller	1
20	218-212	Horn Relay	1
21	18-2130	Clamp	1
22	18-1310	Saddle	2
23	11-6440	Flasher Connector	1
24	32104-77	Self-Tapping Screw	2
25	19-6050	Horn	1
26	18-2820	Horn Mount	1
27	32112-2	Nut	1
28	218-242	Stoplight Switch	1

Ref. No.	Part No.	Description	No. Used
29	218-243	Brake Line Tee	1
30	38-2150	Wire Harness	1
31	38-6170	Support—Slow Moving Vehicle	1
32	322-3	Capscrew	2
33	38-6200	Socket—Slow Moving Vehicle Emblem	1
34	3219-5	Nut	4
35	3253-7	Lockwasher	6
36	3256-6	Washer	4
37	32144-11	Screw Self Tapping	4
38	3256-3	Washer	2
39	18-8860	Bracket Rear	2
40	237-73	Grommet	2
41	3217-11	Nut	2
42	3253-8	Lockwasher	2
43	327-4	Capscrew	2
44	3-3402	Bracket	4
45	60-9380	Tail, Stop & Turn Light	2
46	18-8570	Wire Harness Clip	1
47	212-93	Wire Clip	13
48	3256-55	Washer	2
49	38-2140	Wire Harness	1
50	3219-5	Nut	2
51	11-6250	Front Signal Light (Incl. Ref. #35, 50 & 53)	2
52	32146-5	Nut — Lock	2
53	3256-5	Washer	2
*	62-4510	Anchor, Wire Harness	6

\*Not Illustrated

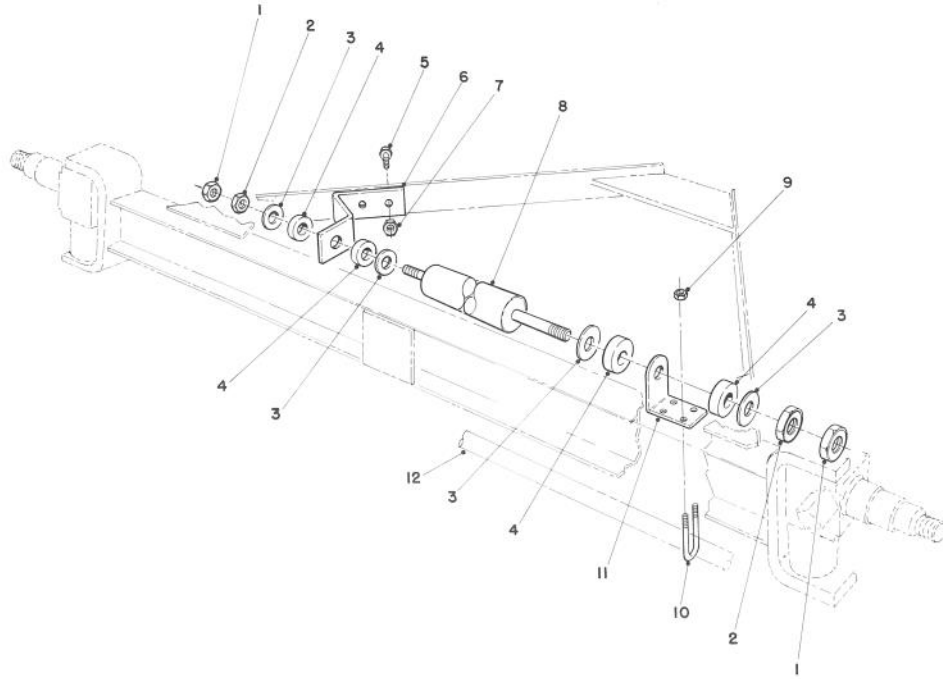

### LIGHT & ROAD KIT NO. 38-6310 (Optional) (Continued)

Ref. No.	Part No.	Description	No. Used
1	3290-385	Locknut	2
2	3219-3	Nut	2
3	60-9460	Washer	4
4	60-9450	Bushing, Rubber	4
5	323-7	Cap screw	2
6	60-9340	Bracket, Stabilizer Mounting	1
7	32128-21	Locknut	2

Ref. No.	Part No.	Description	No. Used
8	60-9360	Stabilizer, Steering	1
9	32128-13	Locknut	4
10	60-9350	U-Bolt, Stabilizer	2
11	60-9370	Bracket	1
12		Tie Rod	1
*	60-9440	Mounting Kit, Stabilizer Hardware	1

\*Not Illustrated

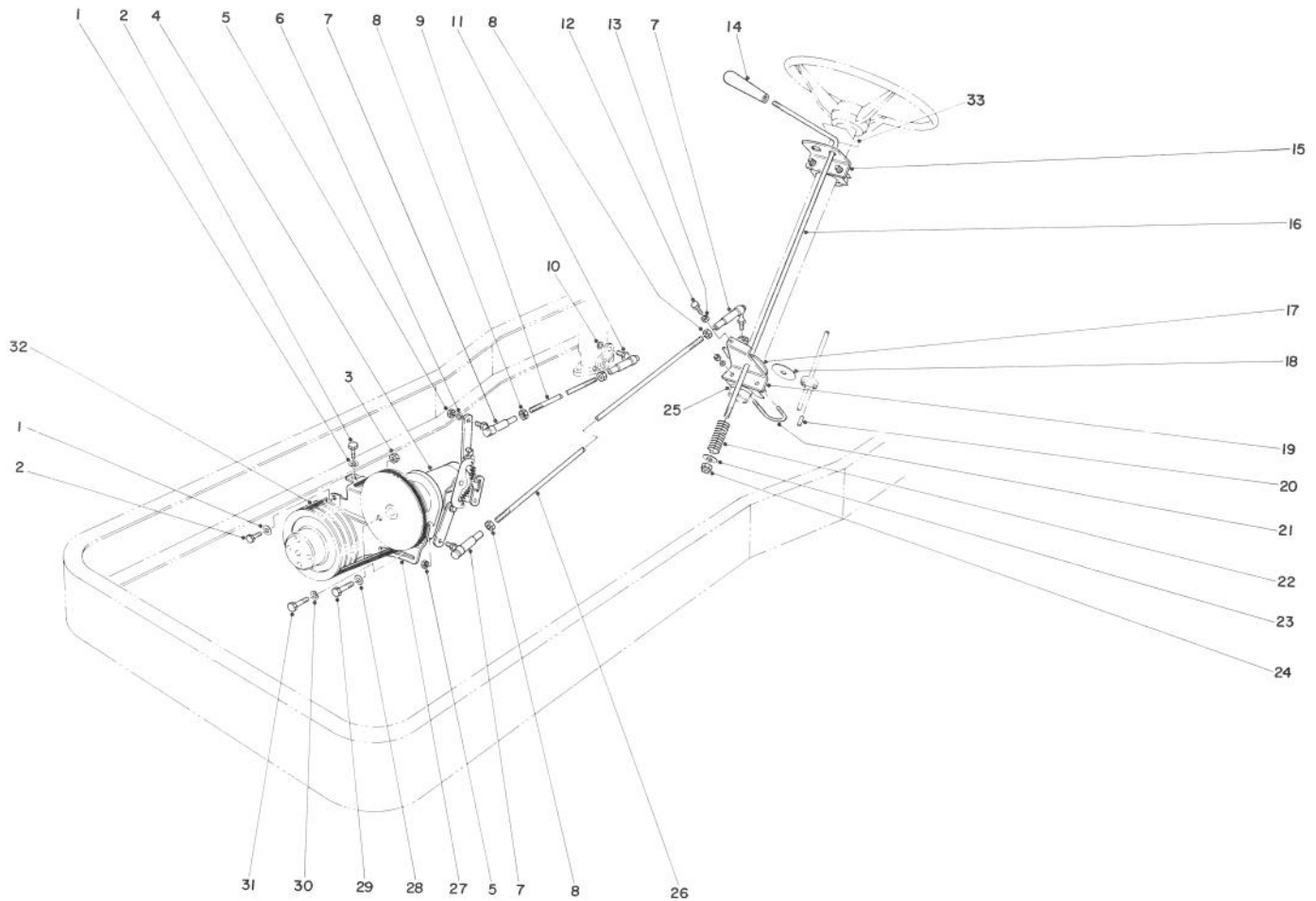

## GOVERNOR KIT NO. 38-2030 (Optional)

Ref. No.	Part No.	Description	No. Used
1	3253-21	Lockwasher	2
2	323-4	Capscrew	2
3	32153-2	Locknut	2
4	18-1700	Governor	1
5	3219-1	Nut	3
6	3253-3	Lockwasher	3
7	18-1720	Ball Joint	3
8	3220-1	Jam Nut	4
9	18-1730	Control Rod	1
10	3253-17	Lockwasher	1
11	18-1710	Ball Joint	1
12	322-5	Capscrew	1
13	3218-2	Jam Nut	1
14	18-2640	Handle	1
15	18-2480	Throttle Lever Support	1
16	18-2710	Lever	1
17	38-1760	Friction Plate	1

Ref. No.	Part No.	Description	No. Used
18	3-2858	Friction Disk	1
19	38-1740	Friction Plate Bracket	1
20	32121-2	Roll Pin	2
21	18-2130	Clamp	2
22	3-8596	Compression Spring	1
23	3256-25	Flat Washer	1
24	3296-7	Nut	1
25	18-1310	Saddle	4
26	18-2500	Control Rod	1
27	18-1400	Governor Bracket	1
28	3256-24	Flatwasher	2
29	323-8	Capscrew	2
30	3253-4	Lockwasher	1
31	322-6	Capscrew	1
32	18-2010	V-Belt	1
33	26-5260	Decal – Throttle Control	1



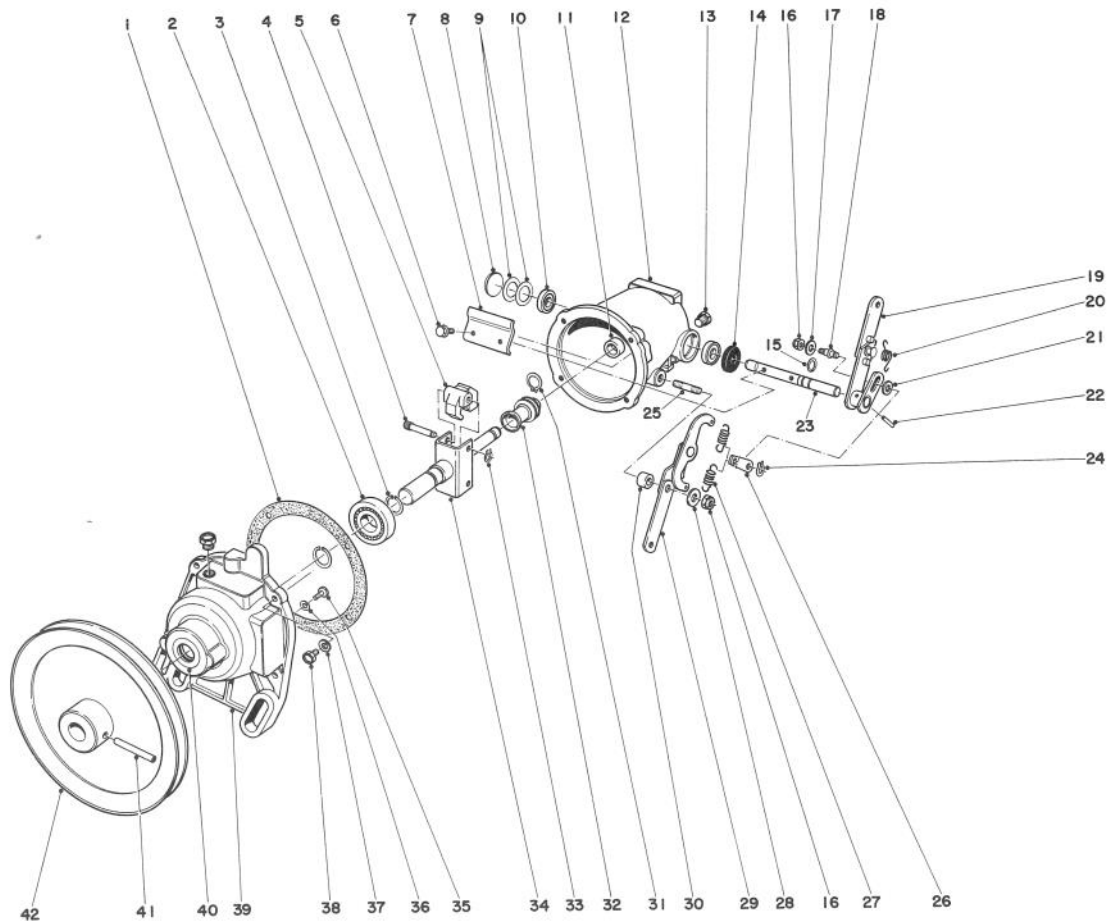

## GOVERNOR ASSEMBLY NO. 18-1700 (Optional)

Ref. No.	Part No.	Description	No. Used
1	18-5790	Gasket	1
2	18-5570	Front Main Bearing	1
3	18-5640	Bearing Retainer	2
4	18-5660	Pivot Pin	2
5	18-5650	Flyweight	2
6	18-5530	Screw	2
7	18-5520	Rocker Lever	1
8	18-5430	Expansion Plug	1
9	18-5440	Spacer	2
10	18-5450	Bearing	2
11	18-5500	Main Bearing (Rear)	1
†12		Body	1
13	18-5510	Oil Plug	2
14	18-5480	Oil Seal	1
15	18-5470	Bearing Retainer	2
16	18-5760	Nut	2
17	18-5740	Washer	1
18	18-5730	Adjusting Pin	1
19	18-5420	Throttle Lever	1
20	18-5410	Torsion Spring	1
21	18-5720	Spacer	1
22	18-5750	Pin	1

Ref. No.	Part No.	Description	No. Used
23	18-5460	Rocker Shaft	1
24	18-5710	Retainer	1
25	18-5700	Stud	1
26	18-5400	Link	1
27	18-5390	Governor Spring	2
28	3256-16	Washer	1
29	18-5380	Variable Speed Lever	1
30	18-5690	Bushing	1
31	18-5540	Retainer	2
32	18-5550	Thrust, Sleeve & Bearing Ass'y.	1
33	18-5670	Retainer	2
34	18-5560	Main Shaft & Carrier Ass'y.	1
35	18-5780	Screw	2
36	18-5770	Lockwasher	2
37	18-5630	Lockwasher	4
38	18-5620	Screw	4
39	18-5590	Cover	1
40	18-5580	Oil Seal	1
41	18-5600	Pin	1
42	18-5610	Pulley	1
*	18-1700	Governor Assembly Complete	1

\*Not Illustrated

†Part only available by ordering 18-1700 Governor Assembly

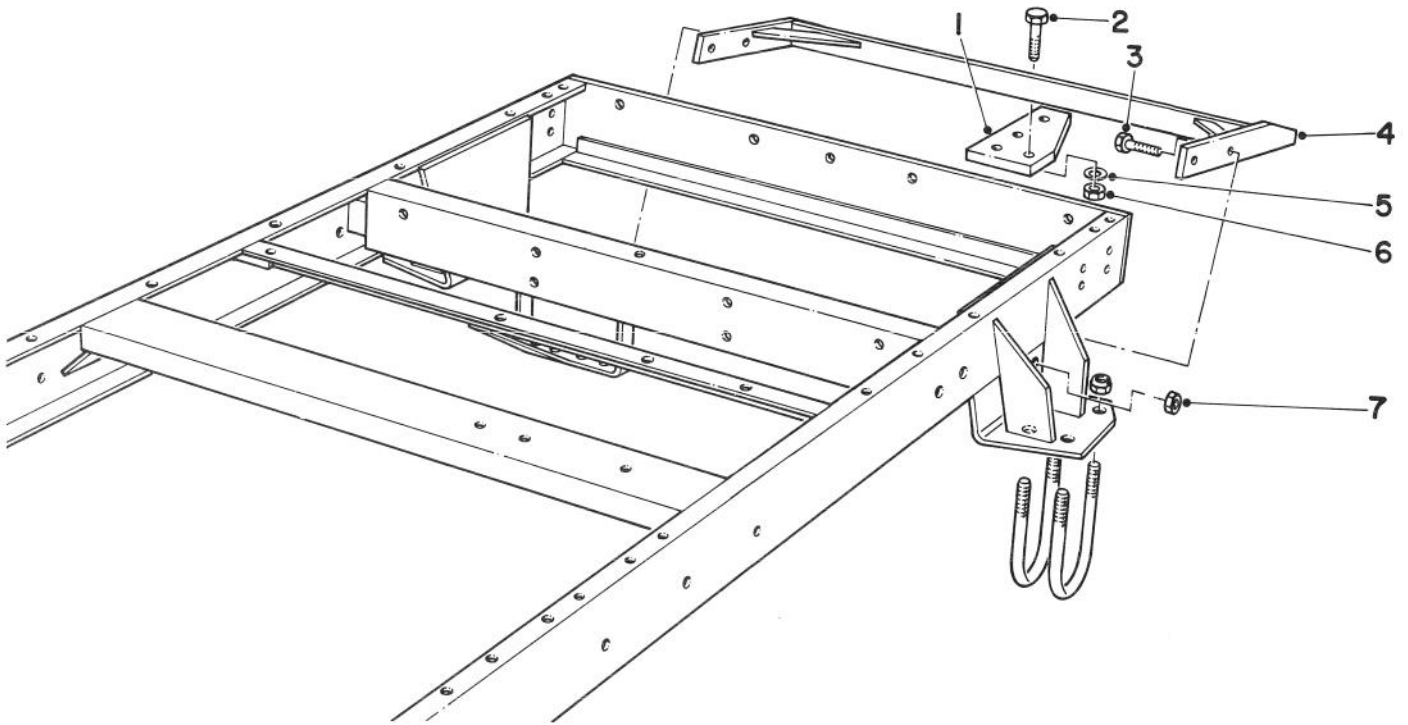

### DRAWBAR KIT (Optional)

Ref. No.	Part No.	Description	No. Used
1	3-3218	Hitch	1
2	328-2	Cap screw	2
3	328-24	Cap screw	4
4	26-9250	Drawbar	1

Ref. No.	Part No.	Description	No. Used
5	3253-9	Lockwasher	2
6	3217-12	Nut	2
7	3296-51	Nut	4

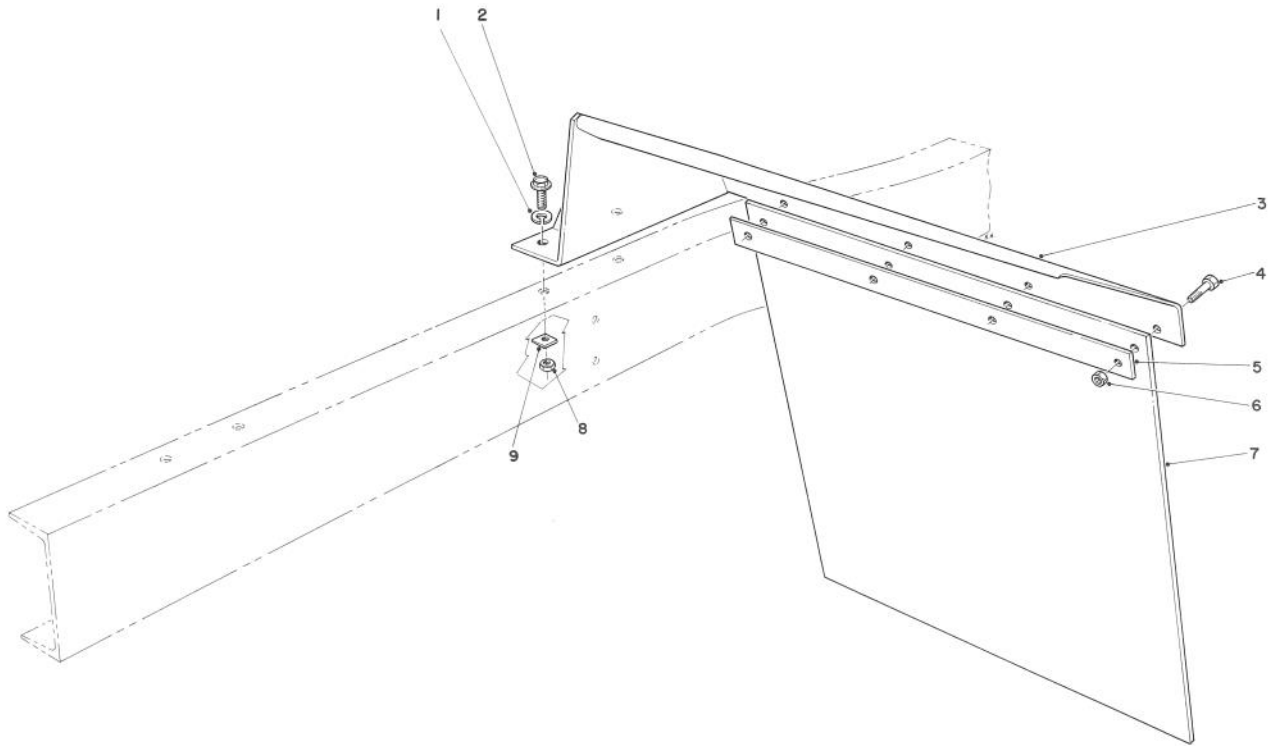

## FRONT FENDER KIT NO. 70196 (Optional)

Ref. No.	Part No.	Description	No. Used
1‡	3253-7	Washer — Lock	2
2	325-5	Screw — Cap Hex. Hd.	4
3	10-2780	Fender — Left	1
*	10-2770	Fender — Right	1
4	323-6	Capscrew	8

Ref. No.	Part No.	Description	No. Used
5	10-2820	Backing — Flap	2
6	32153-2	Nut	8
7	10-2810	Flap	2
8†	32153-5	Nut — Lock	2
9†	3290-216	Washer — Bevel	2

\*Not Illustrated

†Right Hand Fender Only

‡Left Hand Fender Only

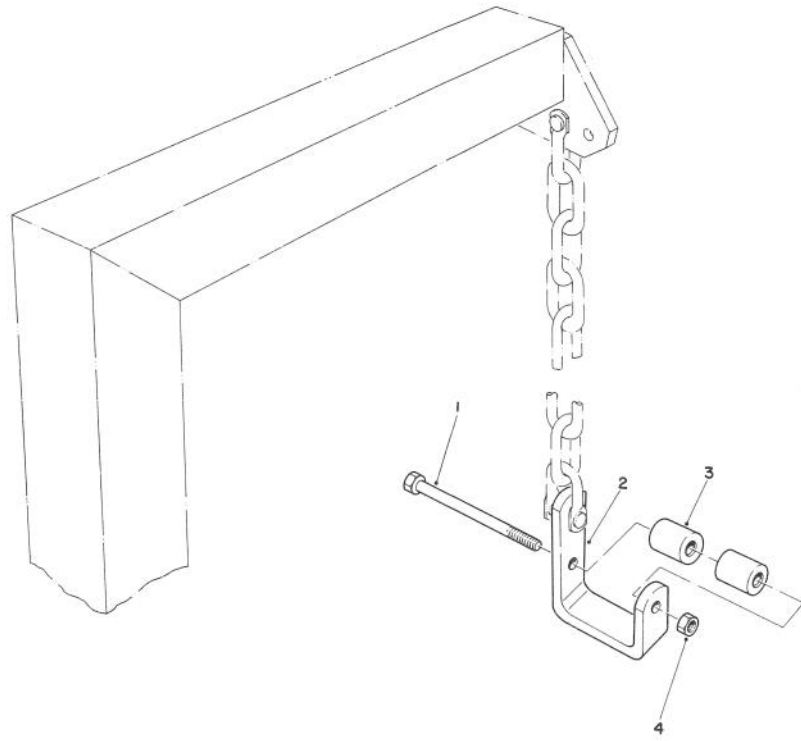

**18" WHEEL, REELMASTER & SPARTAN MOWER  
CONVERSION KIT NO. 51-3080 (Optional)  
(For Cutting Units #6 & #7 Only)**

Ref. No.	Part No.	Description	No. Used
1	323-16	Screw — Cap Hex. Hd.	2
2	51-3180	Bracket — Lift	2

Ref. No.	Part No.	Description	No. Used
3	51-3170	Spacer	4
4	3296-44	Nut - Lock	2

## PRODUCT CHANGES

In an effort to make improvements available to TORO owners as quickly as possible, minor changes are incorporated into Toro's products from time to time that do not become immediately shown in the Parts Catalog. If such a change apparently has been made in your unit, which is not reflected in your manual, see your TORO Distributor for information and part numbers.

## IDENTIFICATION AND ORDERING

### Model and Serial Numbers

The Tractor has two identification numbers: a model number and a serial number. The two numbers are stamped on a plate which is located on right side of toe board. In any correspondence concerning the Tractor, supply model and serial numbers to assure that correct information and replacement parts are obtained.

To order replacement parts from an Authorized TORO Distributor, supply the following information:

1. Model and serial numbers of the Tractor.
2. Part number, description, and quantity of part(s) desired.

**NOTE:** Do not order by reference number if a parts catalog is being used; use the **PART NUMBER**.

## INDEX

Description	Page	Description	Page
Hood Assembly .....	1	Rear Tires and Rims 7.50x16 Field Installed Kit No. 70230 .....	36
Dash Assembly .....	2	Rear Tires and Rims 8.00x16 Field Installed Kit No. 70200 .....	37
Wiring Harness — 12 Volt Negative Ground .....	3	Steering Assembly .....	38
Radiator & Fuel Tank Assembly .....	4	Steering Gear 39-7330 .....	39-40
Toe Board and Battery Assembly .....	5	Pump Power Steering No. 44-7800 .....	41
Brake, Clutch, Throttle Controls .....	6-7	Seat Assembly (60-9070) and Suspension Assembly (46-3430) .....	42
Frame .....	8	Valve Cover and Shield Assembly .....	43
Front Axle Assembly .....	9	Valve Bank & Hoses .....	44
Front Wheel Hub and Wheel — For 9.5 L-14 Tire .....	10	Hydraulic Valve Assembly No. 44-7701 .....	45
Engine Mounting Components .....	11	Drawbar Assembly No. 1, 2 and 3 Position .....	46
Engine Assembly .....	12-13	Main Frame Assembly Front .....	47
Engine .....	14-18	Main Frame Assembly Front Center .....	48-49
Starter Motor Assembly No. 55-7470 .....	19	Main Frame Assembly Rear .....	50-51
62 Amp. Alternator Assembly No. 60-9660 .....	22	10" (22-7520) and 12" (22-7530) Cylinders .....	52
42 Amp. Alternator Assembly No. 39-7370 .....	21	Drawbar Assembly .....	53
Distributor Assembly .....	22	Light & Road Kit No. 38-6310 (Optional) .....	54-55
Carburetor Assembly 18-0740 .....	24	Governor Kit No. 38-2030 (Optional) .....	56
Hydraulic Pump and Reservoir .....	25	Governor Assembly No. 18-1700 (Optional) .....	57
Hydraulic Pump No. 18-8440 .....	26	Drawbar Kit (Optional) .....	58
Clutch Assembly .....	27	Front Fender Kit No. 70196 (Optional) .....	59
Transmission Assembly No. 44-1160 .....	28-29	18" Wheel Reelmaster & Spartan Mower Conversion Kit No. 51-3080 (Optional) (For Cutting Units #6 & #7 Only) .....	60
Transmission Cover .....	30		
Parking Brake Assembly .....	31		
Rear Axle (36-9830) and Drive Line (44-1130) .....	32-33		
Rear Brake Assembly (37-1010 R.H. & 37-1020 L.H.) .....	34-35		





