



**Count on it.**

**Operator's Manual**

**Groundsmaster® 7200 and 7210  
Mower**

Model No. 30360—Serial No. 310000001 and Up

Model No. 30363—Serial No. 310000001 and Up

Model No. 30363TC—Serial No. 310000001 and Up

Model No. 30363TE—Serial No. 310000001 and Up

Model No. 30461—Serial No. 310000001 and Up

Model No. 30462—Serial No. 310000001 and Up

Model No. 30464—Serial No. 310000001 and Up

Model No. 30465—Serial No. 310000001 and Up

Model No. 30464TC—Serial No. 310000001 and Up

Model No. 30467—Serial No. 310000001 and Up

Model No. 30468—Serial No. 310000001 and Up

This product complies with all relevant European directives, for details please see the separate product specific Declaration of Conformity (DOC) sheet.

## WARNING

### CALIFORNIA Proposition 65 Warning

**Diesel engine exhaust and some of its constituents are known to the State of California to cause cancer, birth defects, and other reproductive harm.**

Because in some areas there are local, state, or federal regulations requiring that a spark arrester be used on the engine of this machine, a spark arrester is available as an option. If you require a spark arrester, contact your Authorized Toro Service Dealer.

Genuine Toro spark arresters are approved by the USDA Forestry Service.

**Important:** It is a violation of California Public Resource Code Section 4442 to use or operate the engine on any forest-covered, brush-covered, or grass-covered land without a spark arrester muffler maintained in working order, or the engine constricted, equipped, and maintained for the prevention of fire. Other states or federal areas may have similar laws.

## Introduction

This machine is a ride-on, rotary-blade lawnmower intended to be used by professional, hired operators in commercial applications. It is primarily designed for cutting grass on well-maintained lawns in parks, sports fields, and on commercial grounds. It is not designed for cutting brush, mowing grass and other growth alongside highways, or for agricultural uses.

Read this information carefully to learn how to operate and maintain your product properly and to avoid injury and product damage. You are responsible for operating the product properly and safely.

You may contact Toro directly at [www.Toro.com](http://www.Toro.com) for product and accessory information, help finding a dealer, or to register your product.

Whenever you need service, genuine Toro parts, or additional information, contact an Authorized Service Dealer or Toro Customer Service and have the model and serial numbers of your product ready. Figure 1

identifies the location of the model and serial numbers on the product. Write the numbers in the space provided.

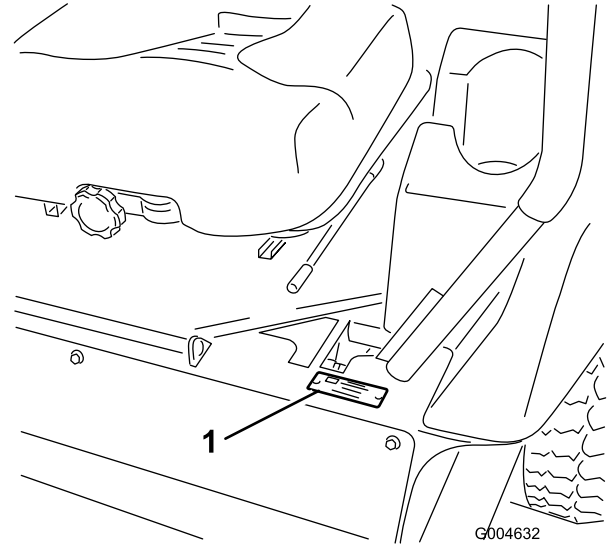


Figure 1

1. Model and serial number location

Model No. _____
Serial No. _____

This manual identifies potential hazards and has safety messages identified by the safety alert symbol (Figure 2), which signals a hazard that may cause serious injury or death if you do not follow the recommended precautions.



Figure 2

1. Safety alert symbol

This manual also uses 2 words to highlight information. **Important** calls attention to special mechanical information and **Note** emphasizes general information worthy of special attention.

# Contents

Introduction.....	2	Daily Maintenance Checklist.....	39
Safety .....	4	Premaintenance Procedures.....	40
Safe Operating Practices .....	4	Lubrication.....	40
Toro Riding Mower Safety .....	6	Greasing the Bearings and Bushings.....	40
Sound Power Level.....	7	Servicing the Mower Deck Gear Box	
Sound Pressure Level .....	7	Lubricant .....	42
Vibration Level .....	7	Engine Maintenance.....	44
Slope Indicator.....	8	Air Cleaner Maintenance .....	44
Safety and Instructional Decals .....	9	Servicing the Engine Oil.....	44
Setup.....	15	Fuel System Maintenance .....	46
1 Installing the Left Rear Tire (Model 30464TC		Servicing the Water Separator .....	46
and 30363TC Only) .....	15	Cleaning the Fuel Tank .....	46
2 Activating and Charging the Battery (Model		Fuel Lines and Connections.....	46
30464TC and 30363TC Only) .....	15	Bleeding the Fuel System .....	46
3 Adjusting the ROPS.....	17	Bleeding Air From the Injectors .....	47
4 Checking the Tire Pressure.....	17	Electrical System Maintenance.....	48
5 Installing Weights (For CE Compliance) .....	18	Servicing the Battery.....	48
6 Checking Fluid Levels .....	18	Storing the Battery.....	48
7 Reading the Manuals and Viewing the		Checking the Fuses.....	48
Training Materials.....	18	Drive System Maintenance .....	49
Product Overview .....	19	Checking the Tire Pressure .....	49
Controls .....	19	Replacing the Castor Wheels and	
Specifications .....	21	Bearings .....	49
Attachments/Accessories.....	21	Cooling System Maintenance.....	50
Operation.....	22	Checking the Cooling System .....	50
Adding Fuel .....	22	Cleaning the Radiator .....	51
Filling the Fuel Tank.....	23	Brake Maintenance.....	52
Checking the Engine Oil Level.....	23	Adjusting the Parking Brake Interlock	
Checking the Cooling System.....	23	Switch .....	52
Checking the Hydraulic System.....	23	Belt Maintenance.....	53
Using the Rollover Protection System		Checking the Alternator Belt .....	53
(ROPS) .....	23	Replacing the Blade Drive Belts .....	53
Think Safety First.....	24	Controls System Maintenance.....	54
Operating the Parking Brake .....	25	Adjusting the Control Lever Neutral Interlock	
Starting and Stopping the Engine .....	26	Switch .....	54
Driving the Machine.....	27	Adjusting the Control Lever Neutral	
Stopping the Machine.....	27	Return.....	54
Operating the Mower .....	28	Adjusting the Traction Drive for Neutral .....	55
Adjusting the Height-of-Cut.....	29	Adjusting the Maximum Ground Speed .....	56
Adjusting the Skid(s).....	29	Adjusting the Tracking.....	57
Adjusting the Rear Anti-Scalp Rollers .....	30	Hydraulic System Maintenance .....	58
Adjusting the Rollers .....	30	Checking the Hydraulic System.....	58
The Safety Interlock System.....	32	Changing the Hydraulic Oil And Filter .....	59
Positioning the Seat .....	33	Mower Deck Maintenance.....	60
Unlatching the Seat.....	34	Servicing the Cutting Blades .....	60
Pushing the Machine by Hand.....	34	Correcting Mower Deck Mismatch .....	62
Loading Machines .....	35	Adjusting the Mower Deck Pitch.....	63
Transporting Machines.....	36	Replacing the Grass Deflector.....	63
Operating Tips .....	36	Cleaning.....	64
Maintenance.....	38	Cleaning Under the Mower .....	64
Recommended Maintenance Schedule(s) .....	38	Waste Disposal.....	64
		Storage.....	65
		Machine .....	65
		Engine .....	65

# Safety

Machines with model numbers 30461, 30462, 30363TC, 30363TE, 30464, 30465, or 30464TC meet or exceed CEN standard EN 836:1997 and ANSI B71.4-2004 specifications in effect at the time of production. Machines with model numbers 30360, 30363, 30467 and 30468 meet or exceed ANSI B71.4-2004 specifications in effect at the time of production.

Improper use or maintenance by the operator or owner can result in injury. To reduce the potential for injury, comply with these safety instructions and always pay attention to the safety alert symbol, which means **Caution, Warning, or Danger**—personal safety instruction. Failure to comply with the instruction may result in personal injury or death.

## Safe Operating Practices

The following instructions are from the CEN standard EN 836:1997 and ANSI B71.4-2004.

This product is capable of amputating hands and feet and throwing objects. Always follow all safety instructions to avoid serious injury or death.

## Training

- Read the *Operator's Manual* and other training material carefully. Be familiar with the controls, safety signs, and the proper use of the equipment.
- Never allow children or people unfamiliar with these instructions to use the lawn mower. Local regulations can restrict the age of the operator.
- Never mow while people, especially children, or pets are nearby.
- Keep in mind that the operator or user is responsible for accidents or hazards occurring to other people or their property.
- Do not carry passengers.
- All drivers should seek and obtain professional and practical instruction. Such instruction should emphasize:
  - the need for care and concentration when working with ride-on machines;
  - control of a ride-on machine sliding on a slope will not be regained by the application of the control levers. The main reasons for loss of control are:
    - ◇ insufficient wheel grip, especially on wet grass;
    - ◇ being driven too fast;

- ◇ inadequate braking;
- ◇ the type of machine is unsuitable for its task;
- ◇ lack of awareness of the effect of ground conditions, especially slopes;
- ◇ incorrect load distribution.

## Preparation

- While mowing, always wear substantial footwear and long trousers. Do not operate the equipment when barefoot or wearing open sandals.
- Thoroughly inspect the area where the equipment is to be used and remove all objects which may be thrown by the machine.
- **Warning**—fuel is highly flammable.
  - Store fuel in containers specifically designed for this purpose.
  - Refuel outdoors only and do not smoke while refueling.
  - Add fuel before starting the engine. Never remove the cap of the fuel tank or add fuel while the engine is running or when the engine is hot.
  - If fuel is spilled, do not attempt to start the engine but move the machine away from the area of spillage and avoid creating any source of ignition until fuel vapors have dissipated.
  - Replace all fuel tank and container caps securely.
- Replace faulty silencers/mufflers.
- Before using, always visually inspect to see that the blades, blade bolts and cutter assembly are not worn or damaged. Replace worn or damaged blades and bolts in sets to preserve balance.

## Operation

- Be alert, slow down and use caution when making turns. Look behind and to the side before changing directions.
- Do not operate the engine in a confined space where dangerous carbon monoxide fumes can collect.
- Mow only in daylight or in good artificial light.
- Before attempting to start the engine, disengage all blade attachment clutches and shift into neutral.
- Remember there is no such thing as a safe slope. Travel on grass slopes requires particular care. To guard against overturning:
  - do not stop or start suddenly when on a slope;
  - use slow speeds on slopes and during tight turns;
  - stay alert for humps and hollows and other hidden hazards;

- Watch out for traffic when crossing or near roadways.
- Stop the blades from rotating before crossing surfaces other than grass.
- When using any attachments, never direct discharge of material toward bystanders nor allow anyone near the machine while in operation.
- Never operate the machine with damaged guards, shields, or without safety protective devices in place.
- Do not change the engine governor settings or overspeed the engine. Operating the engine at excessive speed may increase the hazard of personal injury.
- Before leaving the operator's position:
  - disengage the power take-off and lower the attachments;
  - change into neutral and set the parking brake;
  - stop the engine and remove the key.
- Disengage drive to attachments, stop the engine, and remove the ignition key:
  - before clearing blockages or unclogging chute;
  - before checking, cleaning or working on the lawn mower;
  - after striking a foreign object. Inspect the lawn mower for damage and make repairs before restarting and operating the equipment;
  - if the machine starts to vibrate abnormally (check immediately).
- Do not operate the mower under the influence of alcohol or drugs.
- Lightning can cause severe injury or death. If lightning is seen or thunder is heard in the area, do not operate the machine; seek shelter.
- Disengage drive to attachments when transporting or not in use.
- Stop the engine and disengage drive to attachment before refuelling.

## Maintenance and Storage

- Keep all nuts, bolts and screws tight to be sure the equipment is in safe working condition.
- Never store the equipment with fuel in the tank inside a building where fumes may reach an open flame or spark.
- Allow the engine to cool before storing in any enclosure.
- To reduce the fire hazard, keep the engine, silencer/muffler, battery compartment and fuel storage area free of grass, leaves, or excessive grease.

- Replace worn or damaged parts for safety.
- If the fuel tank has to be drained, do this outdoors.
- On multi-bladed mowers, take care as manually rotating one blade can cause other blades to rotate.
- When machine is to be parked, stored or left unattended, lower the mower deck.
- Reduce speed and use extreme caution on slopes.
- Remove or mark obstacles such as rocks, tree limbs, etc. from the mowing area. Tall grass can hide obstacles.
- Watch for ditches, holes, rocks, dips, and rises that change the operating angle, as rough terrain could overturn the machine.

## Toro Riding Mower Safety

The following list contains safety information specific to Toro products or other safety information that you must know that is not included in the CEN standard.

- Engine exhaust contains carbon monoxide, which is an odorless, deadly poison that can kill you. Do not run engine indoors or in an enclosed area.
- Keep hands, feet, hair and loose clothing away from attachment discharge area, underside of mower and any moving parts while engine is running.
- Do not touch equipment or attachment parts which may be hot from operation. Allow to cool before attempting to maintain, adjust, or service.
- Battery acid is poisonous and can cause burns. Avoid contact with skin, eyes and clothing. Protect your face, eyes, and clothing when working with a battery.
- This machine is not designed or equipped for on-road use and is a “slow-moving vehicle.” If you must cross or travel on a public road, you should be aware of and comply with local regulations, such as required lights, slow moving vehicle signs, and reflectors.
- Battery gases can explode. Keep cigarettes, sparks and flames away from battery.
- Use only genuine Toro replacement parts to ensure that original standards are maintained.
- Use only Toro approved attachments. Warranty may be voided if used with unapproved attachments.

## Slope Operation

- Do not mow near drop-offs, ditches, steep banks or water. Wheels dropping over edges can cause rollovers, which may result in serious injury, death, or drowning.
- Do not mow slopes when grass is wet. Slippery conditions reduce traction and could cause sliding and loss of control.
- Do not make sudden turns or rapid speed changes.
- Use a walk behind mower and/or a hand trimmer near drop-offs, ditches, steep banks or water.

- Avoid sudden starts when mowing uphill because the mower may tip backwards.
- Be aware that loss of traction may occur going downhill. Weight transfer to the front wheels may cause drive wheels to slip and cause loss of braking and steering.
- Always avoid sudden starting or stopping on a slope. If tires lose traction, disengage the blades and proceed slowly off the slope.
- Follow the manufacturer’s recommendations for wheel weights or counterweights to improve stability.
- Use extreme care with attachments. These can change the stability of the machine and cause loss of control.

## Using the Rollover Protection System (ROPS)

- Keep the roll bar in the raised and locked position and use the seat belt when operating the machine.
- Be certain that the seat belt can be released quickly in the event of an emergency.
- Be aware there is no rollover protection when the roll bar is down.
- Check the area to be mowed and never fold the ROPS in areas where there are slopes, drop offs or water.
- Lower the rollbar only when absolutely necessary. **Do not wear the seat belt with the roll bar folded down.**
- Check carefully for overhead clearances (i.e. branches, doorways, electrical wires) before driving under any objects and do not contact them.

## Sound Power Level

**Note:** The data contained in this section only pertains to units marked with the CE logo.

### Model 30363 TC and 30363 TE

This unit has a guaranteed sound power level of 103 dBA, which includes an Uncertainty Value (K) of 1 dBA.

Sound power level was determined according to the procedures outlined in ISO 11094.

### Model 30461

This unit has a guaranteed sound power level of 101 dBA, which includes an Uncertainty Value (K) of 1 dBA.

Sound power level was determined according to the procedures outlined in ISO 11094.

### Model 30462

This unit has a guaranteed sound power level of 102 dBA, which includes an Uncertainty Value (K) of 1 dBA.

Sound power level was determined according to the procedures outlined in ISO 11094.

### Model 30464 and 30464 TC

This unit has a guaranteed sound power level of 102 dBA, which includes an Uncertainty Value (K) of 1 dBA.

Sound power level was determined according to the procedures outlined in ISO 11094.

### Model 30465 TC

This unit has a guaranteed sound power level of 102 dBA, which includes an Uncertainty Value (K) of 1 dBA.

Sound power level was determined according to the procedures outlined in ISO 11094.

## Sound Pressure Level

**Note:** The data contained in this section only pertains to units marked with the CE logo.

### Model 30363 TC and 30363 TE

This unit has a sound pressure level at the operator's ear of 90 dBA, which includes an Uncertainty Value (K) of 1 dBA.

Sound pressure level was determined according to the procedures outlined in EN 836.

### Model 30461

This unit has a sound pressure level at the operator's ear of 87 dBA, which includes an Uncertainty Value (K) of 1 dBA.

Sound pressure level was determined according to the procedures outlined in EN 836.

### Model 30462

This unit has a sound pressure level at the operator's ear of 89 dBA, which includes an Uncertainty Value (K) of 1 dBA.

Sound pressure level was determined according to the procedures outlined in EN 836.

### Model 30464 and 30464 TC

This unit has a sound pressure level at the operator's ear of 88 dBA, which includes an Uncertainty Value (K) of 1 dBA.

Sound pressure level was determined according to the procedures outlined in EN 836.

### Model 30465 TC

This unit has a sound pressure level at the operator's ear of 87 dBA, which includes an Uncertainty Value (K) of 1 dBA.

Sound pressure level was determined according to the procedures outlined in EN 836.

## Vibration Level

**Note:** The data contained in this section only pertains to units marked with the CE logo.

### Hand-Arm

Measured vibration level for right hand = 1.22 m/s<sup>2</sup>

Measured vibration level for left hand = 0.6 m/s<sup>2</sup>

Uncertainty Value (K) = 0.5 m/s<sup>2</sup>

Measured values were determined according to the procedures outlined in EN 836.

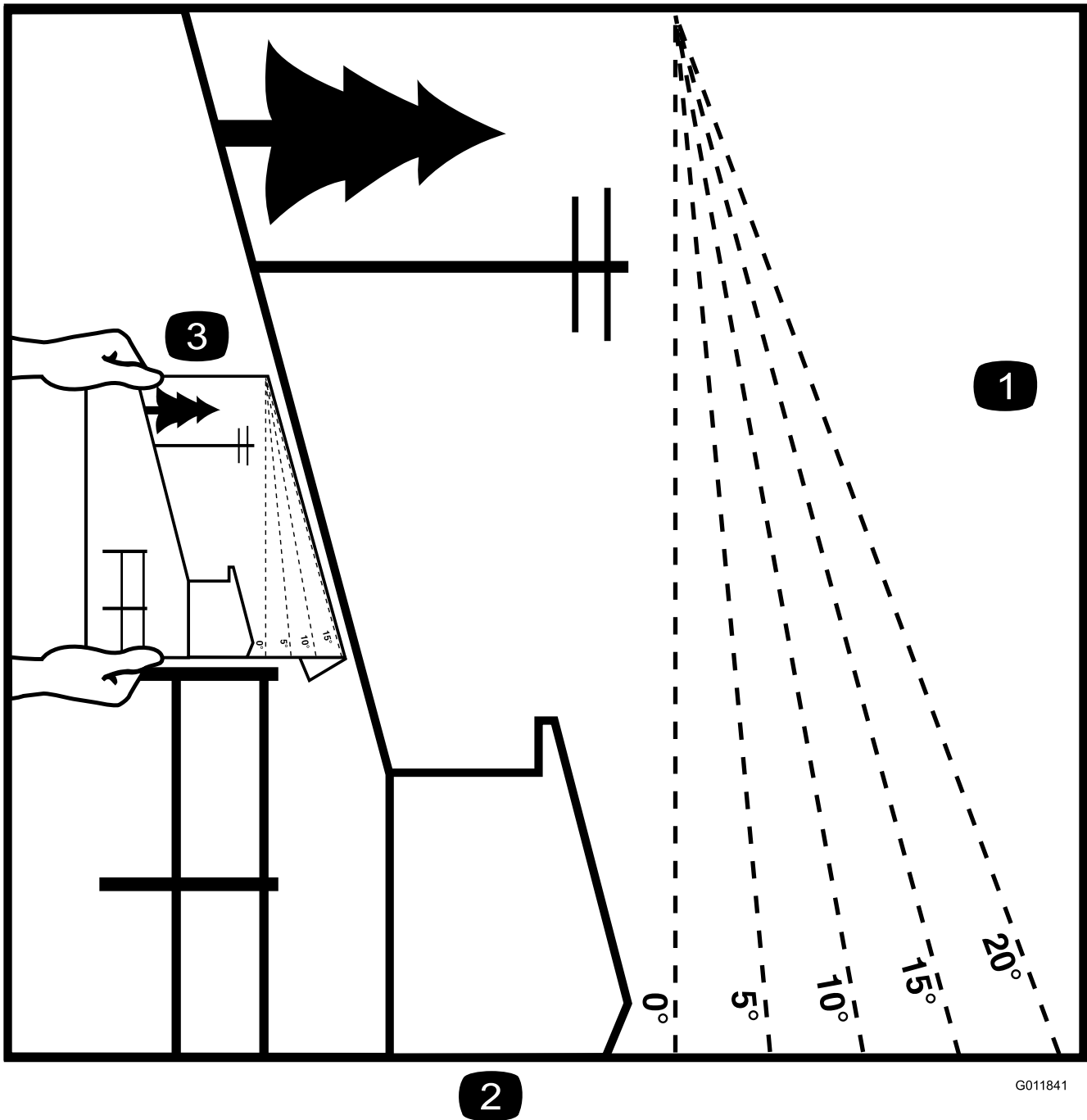
### Whole Body

Measured vibration level = 0.48 m/s<sup>2</sup>

Uncertainty Value (K) = 0.5 m/s<sup>2</sup>

Measured values were determined according to the procedures outlined in EN 836.

# Slope Indicator



2

G011841

Figure 3

This page may be copied for personal use.

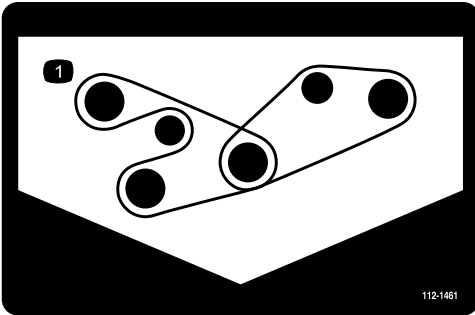
1. The maximum slope you can safely operate the machine on is **15 degrees**. Use the slope chart to determine the degree of slope of hills before operating. **Do not operate this machine on a slope greater than 15 degrees**. Fold along the appropriate line to match the recommended slope.
2. Align this edge with a vertical surface, a tree, building, fence pole, etc.
3. Example of how to compare slope with folded edge.



# Safety and Instructional Decals

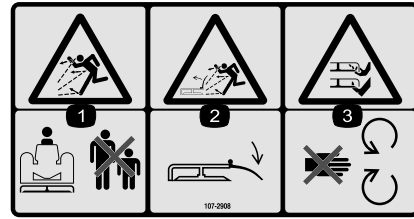


Safety decals and instructions are easily visible to the operator and are located near any area of potential danger. Replace any decal that is damaged or lost.



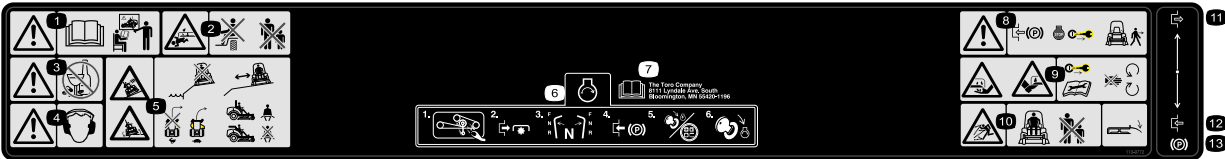
112-1461

1. Belt routing



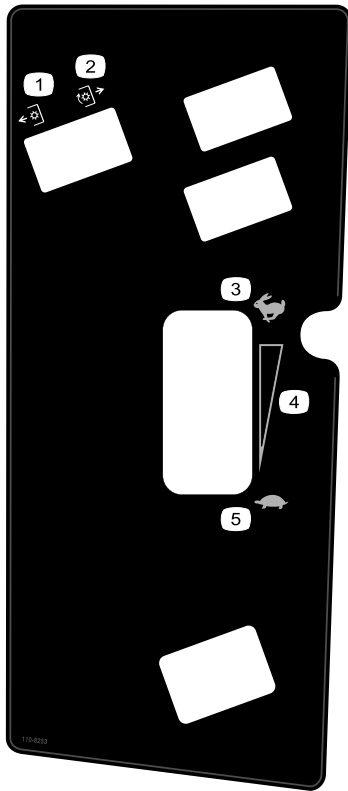
107-2908

1. Thrown object hazard—keep bystanders a safe distance from the machine.
2. Thrown object hazard—do not operate the mower with the deflector up or removed, keep the deflector in place.
3. Cutting/dismemberment hazard of hand or foot, mower blade—stay away from moving parts.



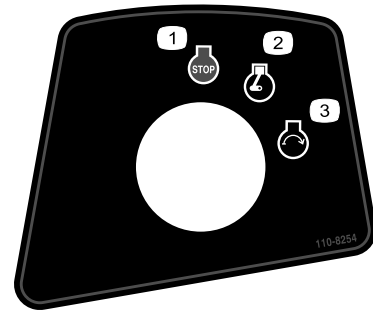
110-9772

1. Warning—read the *Operator's Manual* before operating and do not operate this machine unless you are trained.
2. Crushing/dismemberment hazard of bystanders—do not carry passengers, keep bystanders a safe distance from the machine.
3. Warning—do not use drugs or alcohol.
4. Warning—wear hearing protection.
5. Tipping, drop off hazard—do not operate near water drop-offs, stay a safe distance from drop-offs, slow machine before turning, do not turn at high speeds, wear a seat belt when a ROPS is in place, do not wear a seat belt when ROPS is lowered.
6. To start the engine: clear any debris from the attachment, disengage the PTO, move the motion control levers to the neutral position, engage the parking brake, turn the ignition to Run and wait for the glow plug light to turn off, turn the ignition key to Start.
7. Read the *Operator's Manual*.
8. Warning—engage the parking brake, stop the engine and remove the ignition key before leaving the machine.
9. Cutting hazard of hand or foot—remove the ignition key and read the instructions before servicing or performing maintenance, keep away from moving parts.
10. Thrown object hazard—keep bystanders a safe distance from the machine; keep all deflectors and shields in place.
11. Disengage
12. Engage
13. Parking brake



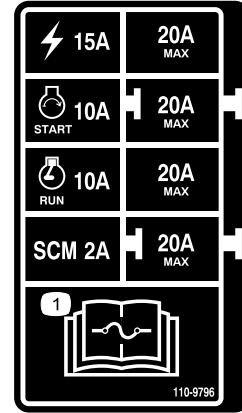
110-8253

- 1. PTO—Off
- 2. PTO—On
- 3. Fast
- 4. Continuous variable setting
- 5. Slow



110-8254

- 1. Engine—Stop
- 2. Engine—Run
- 3. Engine—Start



110-9796

- 1. Read the *Operator's Manual* for information on fuses.

### GROUNDMASTER 7200 / 7210 QUICK REFERENCE AID

**CHECK/SERVICE (daily)**

- 1. OIL LEVEL, ENGINE
- 2. OIL LEVEL, HYDRAULIC TANK
- 3. COOLANT LEVEL, RADIATOR
- 4. FUEL / WATER SEPARATOR
- 5. PRECLEANER - AIR CLEANER
- 6. RADIATOR SCREEN
- 7. BRAKE FUNCTION
- 8. TIRE PRESSURE
- 9. BATTERY
- 10. BELTS - DECK, FAN, ALTERNATOR
- 11. GEARBOX

GREASING - SEE OPERATOR'S MANUAL

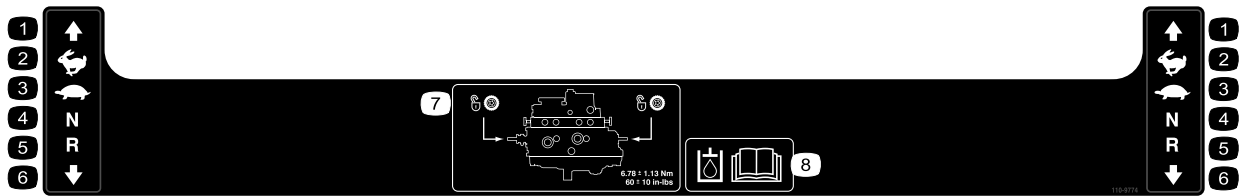
**FLUID SPECIFICATIONS/CHANGE INTERVALS**

SEE OPERATOR'S MANUAL FOR INITIAL CHANGES.	FLUID TYPE	CAPACITY	CHANGE INTERVAL*		FILTER PART NO.
			FLUID	FILTER	
A. ENGINE OIL	*SAE 15W-40	3.9 QTS. WITH FILTER (3.7 LITERS)	150 HRS.	150 HRS.	108-3841
B. HYD. CIRCUIT OIL	MOBIL 424	18.9 QTS. (10.3 LITERS)	800 HRS.	800 HRS.	108-5194
C. AIR CLEANER			SEE INDICATOR		108-3810
D. WATER SEPARATOR			400 HRS.		110-9049
E. FUEL TANK	NO. 2-Diesel	11 GALS. (41 LITERS)	Drain and flush, 2 yrs.		
F. COOLANT	50/50 Ethylene glycol/water	6 QTS. (5.7 LITERS)	Drain and flush, 2 yrs.		
G. GEARBOX	SAE EP90W	12 oz. (355 mL)	400 HRS.		

\*SEE OPERATOR'S MANUAL FOR INITIAL CHANGES / WINTER USE.

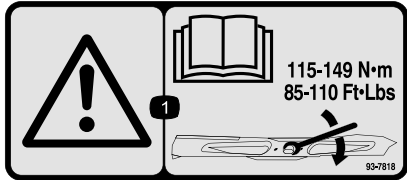
110-8252

- 1. Read the *Operator's Manual*.
- 2. Parking brake
- 3. Hydraulic oil
- 4. Fuel
- 5. Engine coolant
- 6. Engine oil



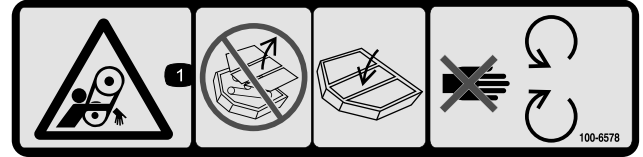
**110-9774**

- |            |            |             |  |
|------------|------------|-------------|--|
| 1. Forward | 3. Slow    | 5. Reverse  | 7. Tow valve location; torque the tow valves to $6.78 \pm 1.13 \text{ N}\cdot\text{m}$ ( $60 \pm 10 \text{ in}\cdot\text{lb}$ ). |
| 2. Fast    | 4. Neutral | 6. Backward | 8. Read the <i>Operator's Manual</i> for more information on the hydraulic oil.  |



**93-7818**

- Warning—read the *Operator's Manual* for instructions on torquing the blade bolt/nut to 115-149 N-m (85-110 ft-lb).



**100-6578**

- Entanglement hazard, belt—do not operate the machine with the shields or guards removed; always keep the shields and guards in place; stay away from moving parts.



**93-6696**

- Stored energy hazard—read the *Operator's Manual*.



**93-6687**

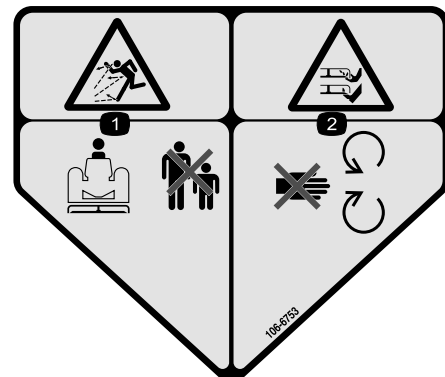
- Do not step here.



**93-6697**

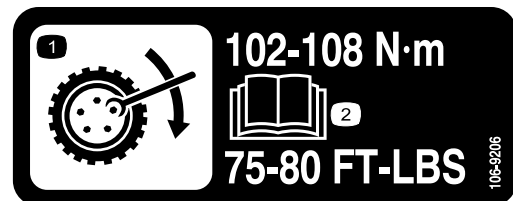
(Model 30631)

- Read the *Operator's Manual*.
- Add SAE 80w-90 (API GL-5) oil every 50 hours.



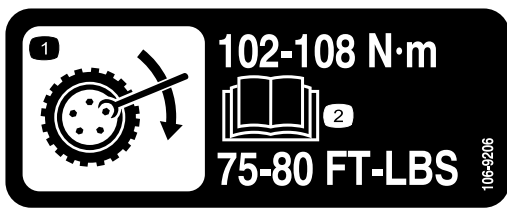
**106-6753**

- Thrown object hazard—keep bystanders a safe distance from the machine.
- Cutting/dismemberment hazard of hand or foot, mower blade—stay away from moving parts.



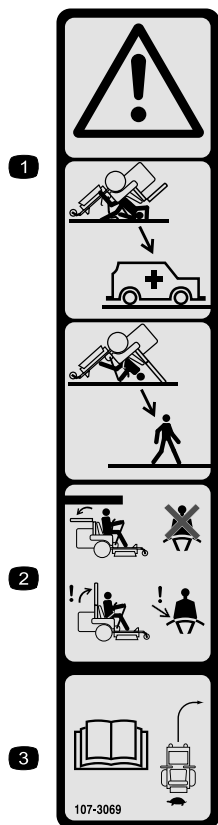
**106-6755**

- Engine coolant under pressure.
- Explosion hazard—read the *Operator's Manual*.
- Warning—do not touch the hot surface.
- Warning—read the *Operator's Manual*.



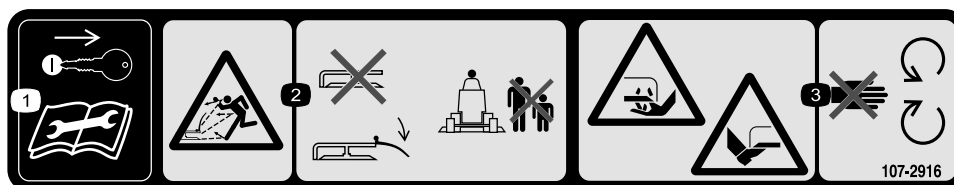
106-9206

1. Wheel torque specifications
2. Read the *Operator's Manual*.



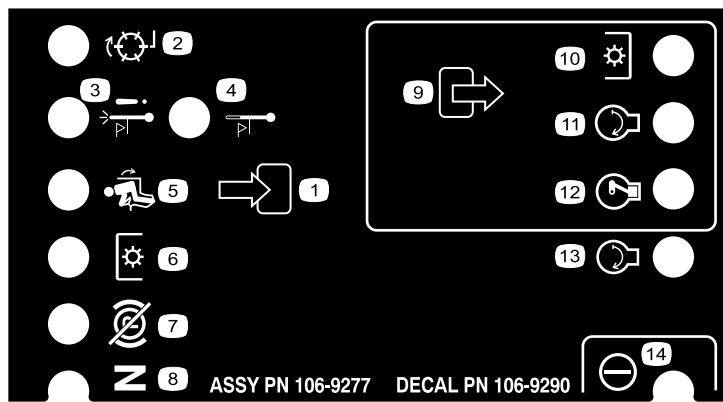
107-3069

1. Warning—there is no rollover protection when the roll bar is down.
2. To avoid injury or death from a rollover accident, keep the roll bar in the raised and locked position and wear the seat belt. Lower the roll bar only when absolutely necessary; do not wear the the seat belt when the roll bar is down.
3. Read the *Operator's Manual*; drive slowly and carefully.



107-2916

1. Remove the ignition key and read the *Operator's Manual* before servicing or performing maintenance.
2. Thrown object hazard—do not operate the mower with the deflector up or removed, keep the deflector in place; keep bystanders a safe distance from the machine.
3. Cutting/dismemberment hazard of hand or foot, mower blade—stay away from moving parts.



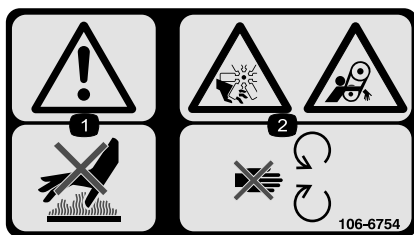
**106-9290**

- |                              |                         |                           |           |
|------------------------------|-------------------------|---------------------------|-----------|
| 1. Inputs                    | 5. In seat              | 9. Outputs                | 13. Start |
| 2. Not active                | 6. Power Take-off (PTO) | 10. Power Take Off (PTO)  | 14. Power |
| 3. High temperature shutdown | 7. Parking brake Off    | 11. Start                 |           |
| 4. High temperature warning  | 8. Neutral              | 12. Energize to Run (ETR) |           |



**110-9781**

- Warning—read the *Operator's Manual*.
- Poison and caustic liquid/chemical burn hazard—keep children a safe distance from the battery.
- Warning—do not touch the hot surface.
- Cutting/dismemberment hazard, fan and entanglement hazard, belt—stay away from moving parts.
- Hydraulic oil in system under pressure, escaping hydraulic oil penetrating skin hazard, broken hydraulic lines hazard—wear protective hand protection when handling hydraulic system components.



**106-6754**

- Warning—do not touch the hot surface.
- Cutting/dismemberment hazard, fan and entanglement hazard, belt—stay away from moving parts.

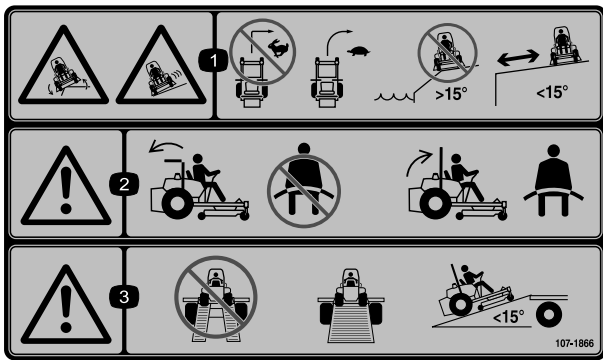


**112-1689**

**CE Marked Models Only (With the CE Kit Installed)**

\* This safety decal includes a slope warning required on the machine for compliance to the European Lawn Mower Safety Standard EN836:1997. The conservative maximum slope angles indicated for operation of this machine are prescribed by and required by this standard.

- Tipping hazard—do not operate on slopes greater than 14 degrees.



107-1866

1. Tipping hazard and sliding or loss of control hazard, drop-offs—do not turn sharply while traveling fast, instead, slow down and turn gradually, do not operate the machine near drop-offs, slopes greater than 15 degrees, or water; keep a safe distance from drop-offs.
2. Warning—if the roll bar is lowered, do not wear the seat belt, if the roll bar is raised, wear the seat belt.
3. Warning—do not use split ramps, use a full ramps when transporting machine, only use ramps with inclines less than 15 degrees.



### Manufacturer's Mark

1. Indicates the blade is identified as a part from the original machine manufacturer.



### Battery Symbols

Some or all of these symbols are on your battery

- |  |  |
|--|--|
| 1. Explosion hazard                    | 6. Keep bystanders a safe distance from the battery.                           |
| 2. No fire, open flame, or smoking.    | 7. Wear eye protection; explosive gases can cause blindness and other injuries |
| 3. Caustic liquid/chemical burn hazard | 8. Battery acid can cause blindness or severe burns.                           |
| 4. Wear eye protection                 | 9. Flush eyes immediately with water and get medical help fast.                |
| 5. Read the <i>Operator's Manual</i> . | 10. Contains lead; do not discard.   |

# Setup

## Loose Parts

Use the chart below to verify that all parts have been shipped.

Procedure	Description	Qty.	Use
<b>1</b>	Tire	1	Install the left rear tire (model 30464TC and 30363TC only).
<b>2</b>	No parts required	–	Activate and charge the battery (model 30464TC and 30363TC only).
<b>3</b>	No parts required	–	Adjust the ROPS.
<b>4</b>	No parts required	–	Check the tire pressure.
<b>5</b>	No parts required	–	Install weights.
<b>6</b>	No parts required	–	Check the hydraulic fluid, engine oil, and coolant levels.
<b>7</b>	Operator's Manual Engine Operator's Manual Parts Catalog Operator Training Material Pre-delivery Inspection Sheet Engine warranty CE certificate	1 1 1 1 1 1 1	Read the manuals and view the training materials before operating the machine. Use the remaining parts for the installation of attachments.

# 1

## Installing the Left Rear Tire (Model 30464TC and 30363TC Only)

### Parts needed for this procedure:

1	Tire
---	------

### Procedure

1. Support the left rear of the machine with jack stands.
2. Remove the lug nuts from the tire mounting studs.
3. Pull the crate and bracket off of the wheel hub.
4. Install the rear tire onto the hub and secure it using the lug nuts previously removed.
5. Torque the lug nuts to 75 to 80 ft-lb (102 to 108 N·m).

# 2

## Activating and Charging the Battery (Model 30464TC and 30363TC Only)

### No Parts Required

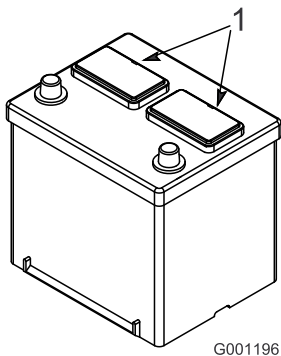
### Procedure

Use only electrolyte (1.265 Specific Gravity) to fill battery initially.

1. Remove the battery from the machine.

**Important: Do not add electrolyte while the battery is in the machine. You could spill it, causing corrosion.**

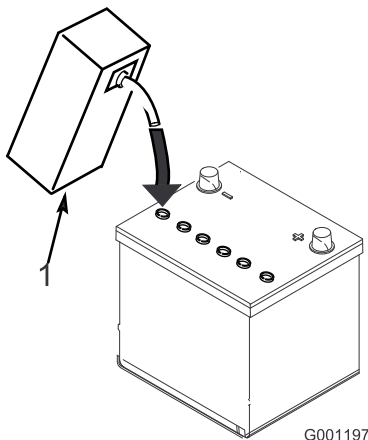
2. Clean the top of the battery and remove the vent caps (Figure 4).



**Figure 4**

1. Vent caps

3. Carefully fill each cell with electrolyte until the plates are covered with about 1/4 inch (6 mm) of fluid (Figure 5).



**Figure 5**

1. Electrolyte

4. Allow approximately 20 to 30 minutes for the electrolyte to soak into the plates. Refill as necessary to bring the electrolyte to within about 1/4 inch (6 mm) of the bottom of the fill well (Figure 5).

**⚠ WARNING**

Charging the battery produces gasses that can explode.

Never smoke near the battery and keep sparks and flames away from battery.

5. Connect a 3 to 4 amp battery charger to the battery posts. Charge the battery at a rate of 3 to 4 amps until the specific gravity is 1.250 or higher and the temperature is at least 60°F. (16°C) with all cells gasing freely.
6. When the battery is charged, disconnect the charger from the electrical outlet and battery posts.

**Note:** After the battery has been activated, add only distilled water to replace normal loss, although maintenance-free batteries should not require water under normal operating conditions.

**WARNING**

**CALIFORNIA  
Proposition 65 Warning**

Battery posts, terminals, and related accessories contain lead and lead compounds, chemicals known to the State of California to cause cancer and reproductive harm.  
Wash hands after handling.

**⚠ WARNING**

Battery terminals or metal tools could short against metal tractor components causing sparks. Sparks can cause the battery gasses to explode, resulting in personal injury.

- When removing or installing the battery, do not allow the battery terminals to touch any metal parts of the tractor.
- Do not allow metal tools to short between the battery terminals and metal parts of the tractor.

7. Install the battery into the machine and secure it.

**Important:** The battery must not be able to move or wiggle when pushed.

8. First, install the positive cable (red) to the positive (+) terminal and then the negative cable (black) to the negative (-) terminal of the battery. Slide the rubber boot over the positive terminal to prevent a possible short from occurring.

**⚠ WARNING**

Incorrect battery cable routing could damage the machine and cables causing sparks. Sparks can cause the battery gasses to explode, resulting in personal injury.

- Always disconnect the negative (black) battery cable before disconnecting the positive (red) cable.
- Always connect the positive (red) battery cable before connecting the negative (black) cable.



## **⚠ WARNING**

Connecting cables to the wrong post could damage the electrical system and result in personal injury.

**Note:** Ensure that the battery cables are routed away from any sharp edges or moving parts.

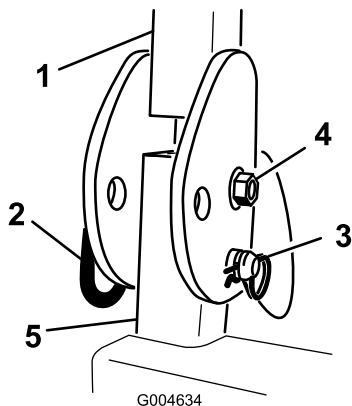
# 3

## Adjusting the ROPS

### No Parts Required

### Procedure

1. Remove the hairpin cotter pins and remove the two pins from the roll bar (Figure 6).



**Figure 6**

Right Side Shown

1. Roll bar
2. Pin
3. Hairpin cotter pin

2. Raise the roll bar to the upright position and install the two pins and secure them with the hairpin cotter pins (Figure 6).

**Note:** If you must lower the roll bar, push the bar forward to relieve pressure on the pins, remove the pins, lower the bar slowly, and secure it with the pins so that it does not damage the hood.

# 4

## Checking the Tire Pressure

### No Parts Required

### Procedure

The tires are over inflated for shipping. Therefore, release some of the air to reduce the pressure. The correct air pressure is 15 psi (103 kPa) in the rear tires and 25 psi (172 kPa) in the caster wheels.

# 5

## Installing Weights (For CE Compliance)

### No Parts Required

### Procedure

Machines with 72 inch decks installed and no other attachments, do not need added weight to meet CE standards. However, you may need to purchase and install additional weight depending on mower deck size/type and the attachments you install on the machine. The following table lists the various attachment configurations and the additional front weight needed for each model:

Attachment Configuration	Weight Required with a 62 inch (157.5 cm) Guardian Mower	Weight Required with a 72 inch (183 cm) Guardian Mower	Weight Required with a 72 inch (183 cm) Side-discharge Mower
Groundsmaster 7200/7210 Traction Unit with no Added Attachments	22 lb (10 kg)	0 lb (0 kg)	0 lb (0 kg)
Groundsmaster 7200/7210 Traction Unit and Hard Canopy	75 lb (34 kg)	21 lb (9.5 kg)	33 lb (15 kg)
Groundsmaster 7200/7210 Traction Unit, Hard Canopy, and Road Light Kit	71 lb (32.2 kg)	63 lb (28.5 kg)	22 lb (10 kg)
Groundsmaster 7200/7210 Traction Unit, Hard Canopy, Road Light Kit, and Jack Stand	40 lb (18 kg)	37 lb (17 kg)	22 lb (10 kg)
Groundsmaster 7200/7210 Traction Unit, Hard Canopy, and Jack Stand	31 lb (14 kg)	22 lb (10 kg)	22 lb (10 kg)
Groundsmaster 7200/7210 Traction Unit, Road Light Kit, and Jack Stand	0 lb (0 kg)	0 lb (0 kg)	0 lb (0 kg)
Groundsmaster 7200/7210 Traction Unit and Road Light Kit	25 lb (11.3 kg)	0 lb (0 kg)	0 lb (0 kg)
Groundsmaster 7200/7210 Traction Unit and Jack Stand	0 lb (0 kg)	0 lb (0 kg)	0 lb (0 kg)

Contact your Authorized Toro Distributor to obtain the appropriate kits and weights for your machine.

# 6

## Checking Fluid Levels

### No Parts Required

### Procedure

1. Check the hydraulic fluid level before starting the engine, refer to Checking the Hydraulic Fluid Level.

2. Check the engine oil level before and after starting the engine, refer to Checking the Engine Oil Level.
3. Check the cooling system before starting the engine; refer to Checking the Cooling System.

# 7

## Reading the Manuals and Viewing the Training Materials

### Parts needed for this procedure:

1	Operator's Manual
1	Engine Operator's Manual
1	Parts Catalog
1	Operator Training Material
1	Pre-delivery Inspection Sheet
1	Engine warranty
1	CE certificate

### Procedure

1. Read the manuals.
2. View the operator training materials.

## Product Overview

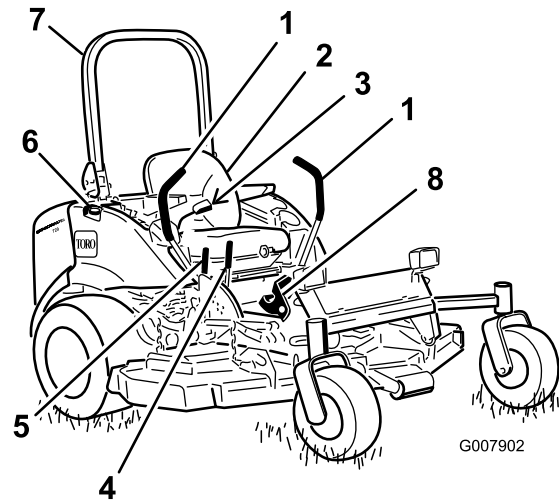


Figure 7

- |                         |                                   |
|-------------------------|-----------------------------------|
| 1. Motion control lever | 5. Mower deck lift lever          |
| 2. Seat                 | 6. Fuel cap (both sides)          |
| 3. Seat belt            | 7. Roll bar                       |
| 4. Parking brake lever  | 8. Foot operated mower lift pedal |

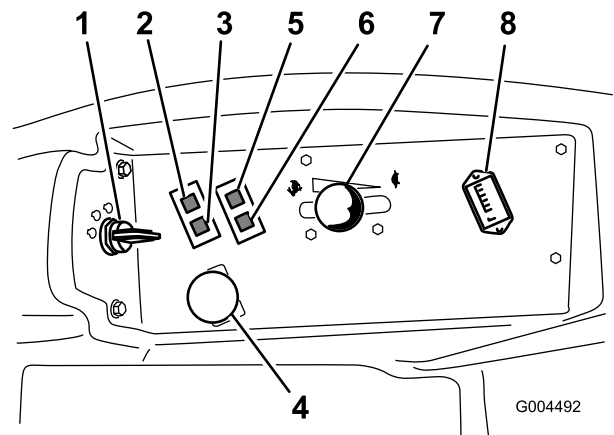


Figure 8

- |   |                               |
|---|-------------------------------|
| 1. Ignition switch                          | 5. Oil pressure warning light |
| 2. Engine coolant temperature warning light | 6. Charge indicator light     |
| 3. Glow plug light                          | 7. Throttle lever             |
| 4. Power take off (PTO) Switch              | 8. Hour meter                 |

## Controls

Become familiar with all the controls before you start the engine and operate the machine (Figure 7 and Figure 8).

### Motion Control Levers

The motion control levers control the forward and rearward motions as well as the turning of the machine. Refer to Driving Forward or Backward.

## Parking Brake Lever

Whenever the engine is shut off, engage the parking brake to prevent accidental movement of the machine. To engage the parking brake, pull the parking brake lever rearward and up (Figure 9). To release the parking brake, push the parking brake lever forward and down.

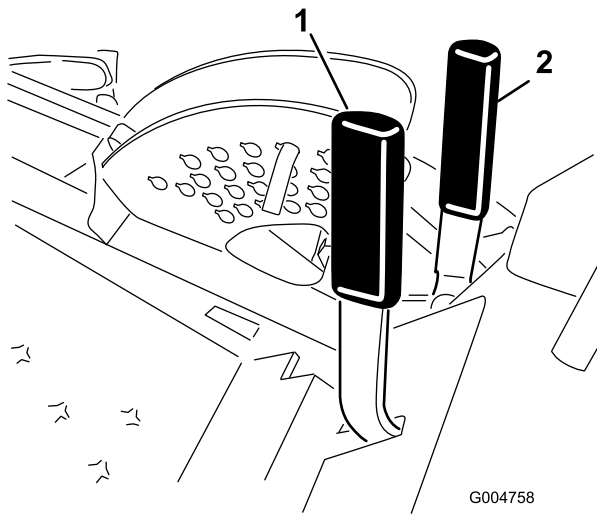


Figure 9

1. Parking brake lever
2. Mower deck lift lever

### **CAUTION**

Do not park the traction unit on a slope.

## Hand Operated Deck Lift Lever

The deck lift lever (Figure 9) activates the hydraulic circuit that raises and lowers the mower deck. Pull back on the lever to raise the mower deck and push forward on it to lower it.

## Foot Operated Deck Lift Pedal

The deck lift pedal (Figure 10) raises and lowers the mower deck. The engine must be running for you to use this pedal. Press down on the top of the lift pedal to raise the mower deck and on the bottom of the lift pedal to lower the mower deck.

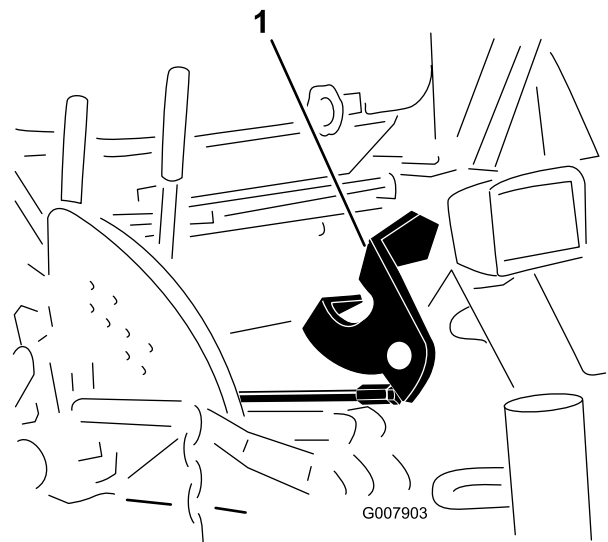


Figure 10

1. Foot operated deck lift lever

## Ignition Switch

The ignition switch has three positions: Off, On/Preheat, and Start.

## Throttle Lever

The throttle lever controls the speed of the engine. Moving the throttle lever forward toward the Fast position increases the engine speed. Moving it rearward toward the Slow position decreases the engine speed. The throttle controls the speed of the blades and, in conjunction with motion control levers, controls ground speed of the machine. Always run the machine with the throttle in the Fast position when cutting grass.

## Power Take Off (PTO) Switch

The power take off (PTO) switch starts and stops the mower blades.

## Hour Meter

The hour meter records the number of hours the engine has operated. It operates when the key switch is in the Run position. Use these times for scheduling regular maintenance.

## Glow Plug Light (Orange Light)

The glow plug indicator light turns on when the ignition switch is turned to the On position. It remains lit for 6 seconds. When the light turns off, the engine is ready to be started.

## Engine Coolant Temperature Warning Light

This light glows and the cutting blades stop if the engine coolant temperature is high. If the machine is not stopped and the coolant temperature rises another 20° F, the engine will stop.

**Important:** If the mower deck shuts down and the temperature warning light is on, push PTO knob down, drive to a safe flat area, move the throttle lever to the Slow position, move the motion control levers into the neutral locked position, and engage the parking brake. Allow the engine to idle for several minutes while it cools to a safe level. Stop the engine and check the cooling system; refer to Checking the Cooling System.

## Charge Indicator

Illuminates when the system charging circuit malfunctions.

## Oil Pressure Warning Light

The oil pressure warning light glows when the oil pressure in engine drops below a safe level. If low oil pressure ever occurs, stop the engine and determine the cause. Repair the damage before starting the engine again.

## Fuel Gauge

The fuel gauge (Figure 11) indicates the quantity of fuel remaining in the fuel tanks.

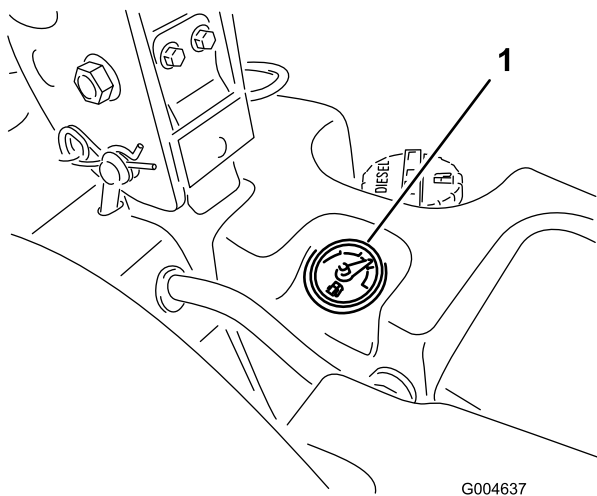


Figure 11

G004637

1. Fuel gauge

## Specifications

**Note:** Specifications and design are subject to change without notice.

Length	97 inches (246.4 cm)
Width (Rear Wheels)	57 inches (144.8 cm)
Height (Roll Bar Up)	72 inches (182.9 cm)
Height (Roll Bar Down)	48 inches (121.9 cm)
Weight, Model 30360, 30360TE, 30363, 30363TE, 30363TC	2230 lb (1011 kg)
Weight, Model 30461 and 30464	2206 lb (1000 kg)
Weight, Model 30462 and 30465	2151 lb (975 kg)
Weight, Model 30467 and 30468	2140 lb (971 kg)

## Attachments/Accessories

A selection of Toro approved attachments and accessories are available for use with the machine to enhance and expand its capabilities. Contact your Authorized Service Dealer or Distributor or go to [www.Toro.com](http://www.Toro.com) for a list of all approved attachments and accessories.

# Operation

**Note:** Determine the left and right sides of the machine from the normal operating position.

## ⚠ CAUTION

**This machine produces sound levels in excess of 85 dBA at the operators ear and can cause hearing loss through extended periods of exposure.**

**Wear hearing protection when operating this machine.**

## Adding Fuel

Use only clean, fresh diesel fuel or biodiesel fuels with low (<500 ppm) or ultra low (<15 ppm) sulfur content. The minimum cetane rating should be 40. Purchase fuel in quantities that can be used within 180 days to ensure fuel freshness.

**Fuel tank capacity:** 11.5 US gallons (43.5 l)

Use summer grade diesel fuel (No. 2-D) at temperatures above 20° F (-7° C) and winter grade (No. 1-D or No. 1-D/2-D blend) below that temperature. Use of winter grade fuel at lower temperatures provides lower flash point and cold flow characteristics which will ease starting and reduce fuel filter plugging.

Use of summer grade fuel above 20° F (-7° C) will contribute toward longer fuel pump life and increased power compared to winter grade fuel.

**Important:** Do not use kerosene or gasoline instead of diesel fuel. Failure to observe this caution will damage the engine.

## ⚠ WARNING

**Fuel is harmful or fatal if swallowed. Long-term exposure to vapors can cause serious injury and illness.**

- Avoid prolonged breathing of vapors.
- Keep face away from nozzle and gas tank or conditioner opening.
- Keep fuel away from eyes and skin.

## Biodiesel Ready

This machine can also use a biodiesel blended fuel of up to B20 (20% biodiesel, 80% petrodiesel). The petrodiesel portion should be low or ultra low sulfur. Observe the following precautions:

- The biodiesel portion of the fuel must meet specification ASTM D6751 or EN14214.

- The blended fuel composition should meet ASTM D975 or EN590.
- Painted surfaces may be damaged by biodiesel blends.
- Use B5 (biodiesel content of 5%) or lesser blends in cold weather.
- Monitor seals, hoses, gaskets in contact with fuel as they may be degraded over time.
- Fuel filter plugging may be expected for a time after converting to biodiesel blended.
- Contact your distributor if you wish for more information on biodiesel.

## ⚠ DANGER

**In certain conditions, fuel is extremely flammable and highly explosive. A fire or explosion from fuel can burn you and others and can damage property.**

- **Fill the fuel tank outdoors, in an open area, when the engine is cold. Wipe up any fuel that spills.**
- **Never fill the fuel tank inside an enclosed trailer.**
- **Never smoke when handling fuel, and stay away from an open flame or where fuel fumes may be ignited by a spark.**
- **Store fuel in an approved container and keep it out of the reach of children. Never buy more than a 30-day supply of fuel.**
- **Do not operate without entire exhaust system in place and in proper working condition.**

## **⚠ DANGER**

In certain conditions during fueling, static electricity can be released causing a spark which can ignite the fuel vapors. A fire or explosion from fuel can burn you and others and can damage property.

- Always place fuel containers on the ground away from your vehicle before filling.
- Do not fill fuel containers inside a vehicle or on a truck or trailer bed because interior carpets or plastic truck bed liners may insulate the container and slow the loss of any static charge.
- When practical, remove equipment from the truck or trailer and refuel the equipment with its wheels on the ground.
- If this is not possible, then refuel such equipment on a truck or trailer from a portable container, rather than from a fuel dispenser nozzle.
- If a fuel dispenser nozzle must be used, keep the nozzle in contact with the rim of the fuel tank or container opening at all times until fueling is complete.

## Filling the Fuel Tank

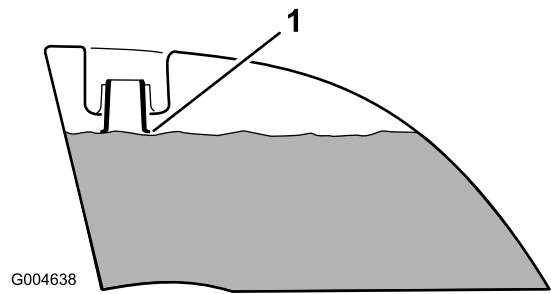
1. Park the machine on a level surface.

**Important:** The fuel tanks are connected, but the fuel does not transfer quickly from one tank to the other. It is important when filling that you park on a level surface. If you park on a hill, you may inadvertently overfill the tanks.

2. Shut the engine off and set the parking brake.
3. Clean around each fuel tank cap and remove the cap.

**Important:** Do not open the fuel tanks when parked on a hill. The fuel could spill out.

4. Add fuel to both fuel tanks, until the level is even with the bottom of the filler neck (Figure 12). Do not over fill the fuel tanks.



**Figure 12**

1. Bottom of the filler neck

5. Install the fuel tank caps securely. Wipe up any fuel that may have spilled.

**Note:** If possible, fill the fuel tanks after each use. This will minimize possible buildup of condensation inside the fuel tank.

## Checking the Engine Oil Level

Before you start the engine and use the machine, check the oil level in the engine crankcase; refer to Checking Oil Level.

## Checking the Cooling System

Before you start the engine and use the machine, check the cooling system; refer to Checking the Cooling System.

## Checking the Hydraulic System

Before you start the engine and use the machine, check the hydraulic system; refer to Checking the Hydraulic System.

## Using the Rollover Protection System (ROPS)

### **⚠ WARNING**

To avoid injury or death from rollover: keep the roll bar in the raised locked position and use the seat belt.

Ensure that the rear part of the seat is secured with the seat latch.

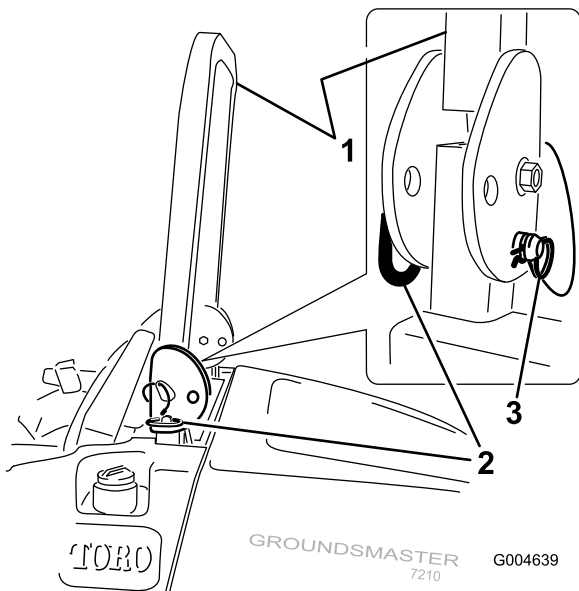
## ⚠ WARNING

There is no rollover protection when the roll bar is in the down position.

- Lower the roll bar only when absolutely necessary.
- Do not wear the seat belt when the roll bar is in the down position.
- Drive slowly and carefully.
- Raise the roll bar as soon as clearance permits.
- Check carefully for overhead clearances (i.e. branches, doorways, electrical wires) before driving under any objects and do not contact them.

**Important:** Lower the roll bar only when absolutely necessary.

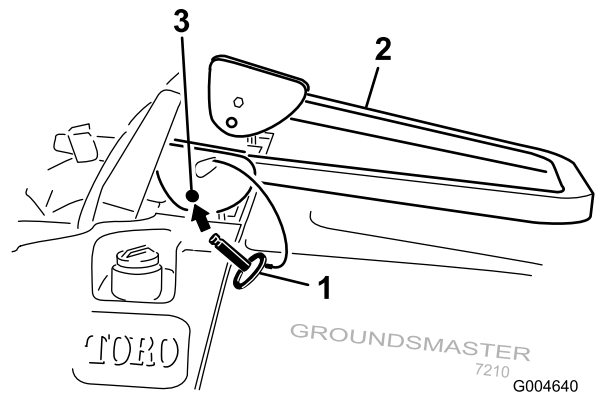
1. To lower the roll bar, remove the hairpin cotters, push the roll bar forward against the springs, and remove the two pins (Figure 13).



**Figure 13**

1. Roll bar
2. Pin
3. Hairpin cotter

2. Lower the roll bar to the down position (Figure 14).



**Figure 14**

1. Pin
2. Roll bar
3. Mounting hole

3. Install the two pins and secure them with the hairpin cotter pins (Figure 13).

**Important:** Ensure that the rear part of the seat is secured with the seat latch.

4. To raise the roll bar, remove the hairpin cotter pins and remove the two pins (Figure 13).
5. Raise the roll bar to the upright position and install the two pins and secure them with the hairpin cotter pins (Figure 13).

**Important:** Always use the seat belt when the roll bar is in the raised and locked position. Do not use the seat belt when the roll bar is in the lowered position.

## Think Safety First

Please read all safety instructions and symbols in the safety section. Knowing this information could help you or bystanders avoid injury.



## **⚠ DANGER**

Operating on wet grass or steep slopes can cause sliding and loss of control.

Wheels dropping over edges can cause rollovers, which may result in serious injury, death or drowning.

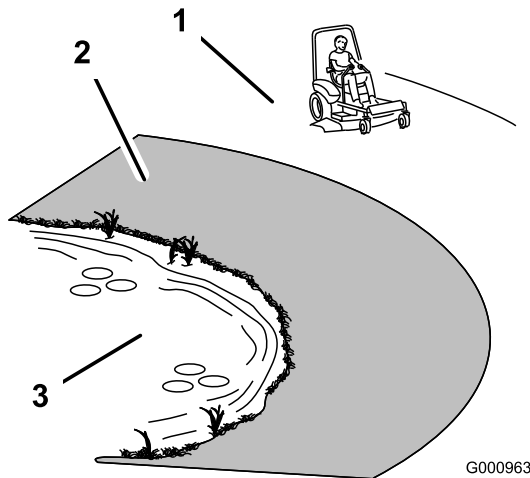
There is no rollover protection when the roll bar is down.

Always keep the roll bar in the raised and locked position and use the seat belt.

Read and follow the rollover protection instructions and warnings.

To avoid loss of control and possibility of rollover:

- Do not operate near drop-offs or near water.
- Reduce speed and use extreme caution on slopes.
- Avoid sudden turns or rapid speed changes.



**Figure 15**

1. Safe Zone
2. Use walk behind mower and/or hand trimmer near drop-offs and water.
3. Water

## **⚠ CAUTION**

This machine produces sound levels in excess of 85 dBA at the operators ear and can cause hearing loss through extended periods of exposure.

Wear hearing protection when operating this machine.

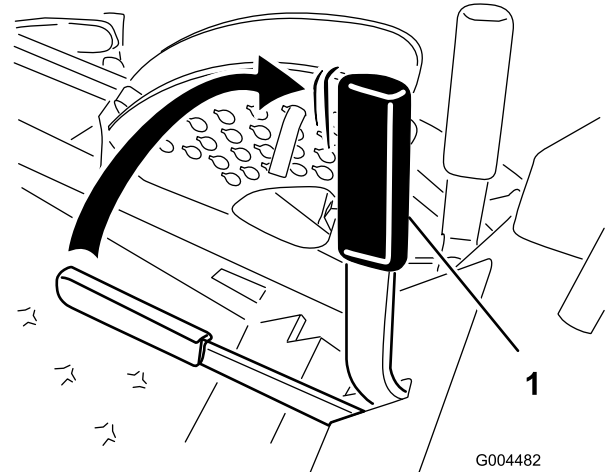
The use of protective equipment for eyes, ears, feet and head is recommended.

## **Operating the Parking Brake**

Always set the parking brake when you stop the machine or leave it unattended.

### **Setting the Parking Brake**

1. Move the motion control levers (Figure 20) out to the neutral locked position.
2. Pull up and back on the parking brake lever to set the parking brake (Figure 16). The parking brake lever should stay firmly in the engaged position.



**Figure 16**

1. Parking brake lever

## **⚠ WARNING**

The parking brake may not hold the machine parked on a slope and could cause personal injury or property damage.

Do not park on slopes unless the wheels are chocked or blocked

### **Releasing the Parking Brake**

Push forward and down on the parking brake lever to release the parking brake (Figure 16).

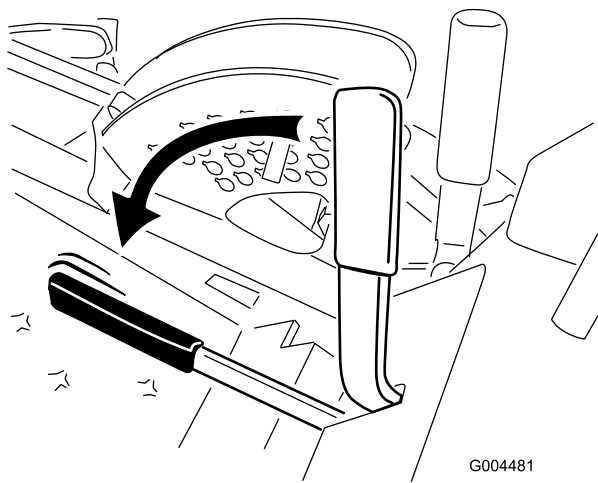


Figure 17

G004481

## Starting and Stopping the Engine

### Starting the Engine

1. Raise the roll bar up and lock it into place, sit on the seat, and fasten the seat belt.
2. Ensure that the motion controls are in the neutral locked position.
3. Set the parking brake; refer to Setting the Parking Brake.
4. Move the PTO (power take off) switch to the off position (Figure 18).

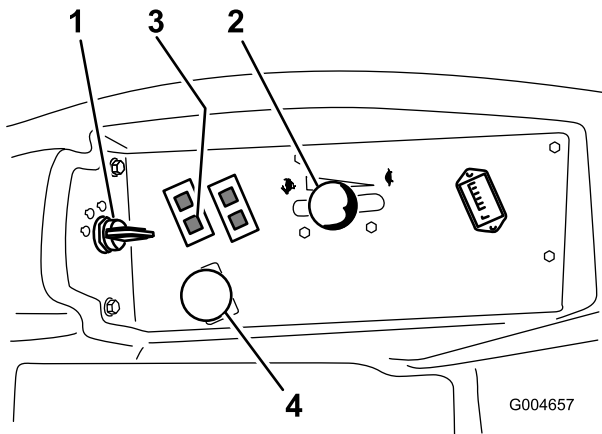


Figure 18

G004657

- |                     |                                |
|---------------------|--------------------------------|
| 1. Ignition switch  | 3. Glow plug light             |
| 2. Throttle control | 4. Power take off switch (PTO) |

5. Move the throttle lever midway between the Fast and Slow positions (Figure 18).
6. Turn the ignition key clockwise to the Run position (Figure 19).

The glow plug light will turn on for 6 seconds.

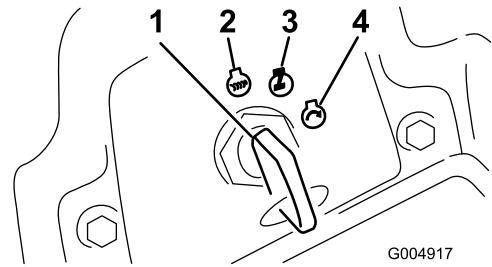


Figure 19

G004917

- |                    |                  |
|--------------------|------------------|
| 1. Ignition switch | 3. Run/glow plug |
| 2. Off             | 4. Start         |

7. After the glow plug indicator light goes out, turn the key to the Start position. When the engine starts release the key.

**Important:** Use starting cycles of no more than 15 seconds per minute to avoid overheating the starter motor.

**Note:** Additional starting cycles may be required when starting the engine for the first time after the fuel system has been completely drained.

8. Leave the throttle midway between the Slow and Fast positions until the engine and hydraulic system warm up.

**Important:** When engine is started for the first time, or after an engine oil change, or an overhaul of the engine, transmission, or wheel motor, operate the machine with the throttle lever in the Slow position in both the forward and reverse directions for one to two minutes. Also operate the lift lever and PTO lever to ensure proper operation of all parts. Then shut the engine off and check fluid levels, check for oil leaks, loose parts, and any other noticeable malfunctions.

### ⚠ CAUTION

Shut the engine off and wait for all moving parts to stop before checking for oil leaks, loose parts, or other malfunctions.

### Stopping the Engine

1. Disengage the PTO, move the motion control levers to the neutral locked position, set the parking brake, and move the throttle lever to the Slow position.
2. Let the engine idle for 60 seconds.

- Turn the ignition key to the Off position (Figure 19). Wait for all moving parts to stop before leaving the operating position.
- Remove the key before transporting or storing machine.

**Important:** Make sure to remove the key as the fuel pump or accessories may run and cause the battery to lose charge.

### ⚠ CAUTION

Children or bystanders may be injured if they move or attempt to operate the tractor while it is unattended.

Always remove the ignition key and set the parking brake when leaving the machine unattended, even if just for a few minutes.

## Driving the Machine

The throttle control regulates the engine speed as measured in rpm (revolutions per minute). Place the throttle control in the Fast position for best performance. Always operate in the Fast throttle position when mowing.

### ⚠ CAUTION

The machine can turn very rapidly. You may lose control of it and cause personal injury or damage to machine.

- Use caution when making turns.
  - Slow the machine down before making sharp turns.
- Release the parking brake; refer to Releasing the Parking Brake.
 

**Note:** The engine will kill if the traction control levers are moved with the parking brake engaged.
  - Move the levers to the center, unlocked position.
  - Drive the machine as follows:
    - To go straight forward, slowly push the motion control levers forward (Figure 20).
    - To go Straight backward, slowly pull the motion control levers rearward (Figure 20).
    - To turn, slow the machine by pulling back on both levers and then push forward on the lever on the opposite side from which you want to turn (Figure 20).
    - To stop, pull the motion control levers to the neutral position.

**Note:** The farther you move the traction control levers in either direction, the faster the machine will move in that direction.

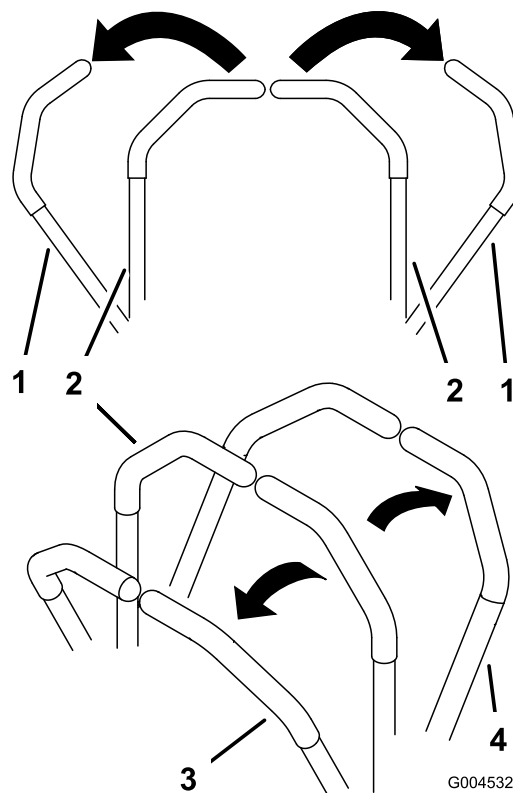


Figure 20

- |   |             |
|---|-------------|
| 1. Motion control lever-neutral locked position | 3. Forward  |
| 2. Center unlock position                       | 4. Backward |

## Stopping the Machine

To stop the machine, move the traction control levers to neutral and to the locked position, disengage the power take off (PTO), move the throttle to the Slow position, and stop the engine.

Set the parking brake when you leave the machine; refer to Setting the Parking Brake. Remember to remove the key from the ignition switch.

### ⚠ CAUTION

Children or bystanders may be injured if they attempt to move or operate the tractor while it is unattended.

Always remove the ignition key and set the parking brake when leaving the machine unattended, even if just for a few minutes.

# Operating the Mower

## Raising and Lowering the Mower with the Deck Lift Lever

The deck lift lever raises and lowers the mower deck (Figure 21). The engine must be running for you to use this lever.

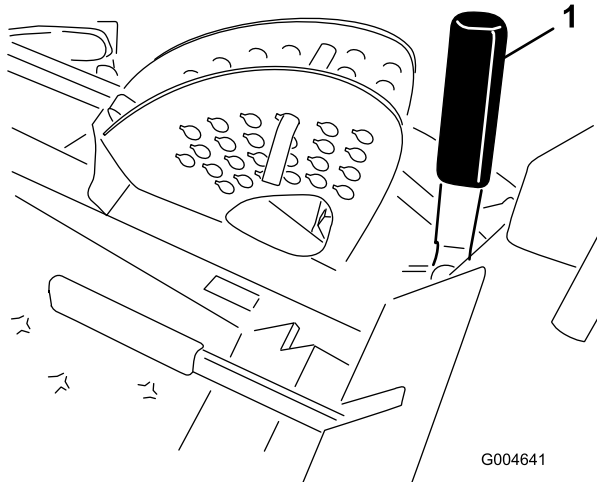


Figure 21

1. Deck lift lever

- To lower the mower deck, push the lever forward.
- To raise the mower deck, pull the lever rearward.

**Important:** Do not continue to hold the lever back or forward after the mower has fully raised or lowered. Doing so will damage the hydraulic system.

**Note:** To lock the mower deck in a raised position, raise the deck past the 6 inch (15 cm) position, remove the height of cut stop pin (refer to Adjusting the Height-of-Cut), and place the pin in the 6 inch (15 cm) height-of-cut position (Figure 24).

## Raising and Lowering the Mower with the Deck Lift Pedal

The foot operated lift pedal raises and lowers the mower deck (Figure 22). The engine must be running for you to use this pedal.

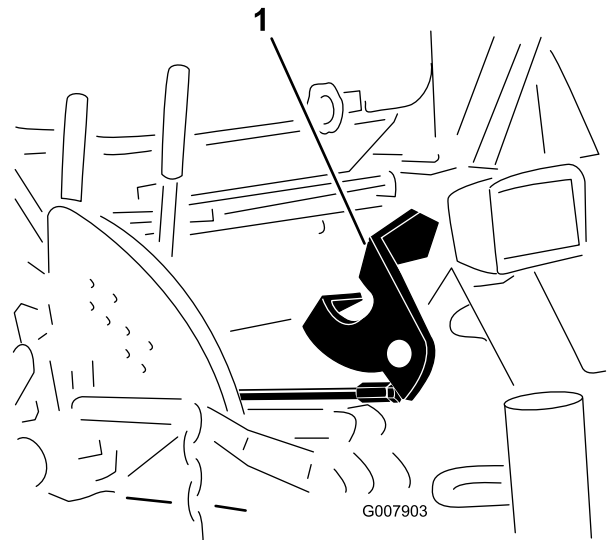


Figure 22

1. Foot operated deck lift pedal

- Press down on the top of lift pedal to raise the mower deck.
- Press down on the bottom of lift pedal to lower the mower deck.

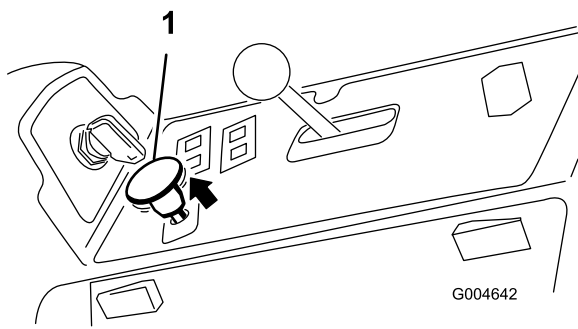
**Important:** Do not continue to hold the pedal down after the mower deck has been fully raised or lowered. Doing so will damage the hydraulic system.

**Note:** To lock the mower deck in a raised position, raise the deck past the 6 inch (15 cm) position, remove the height of cut stop pin (refer to Adjusting the Height-of-Cut), and place the pin in the 6 inch (15 cm) height-of-cut position (Figure 24).

## Engaging the Power Take Off (PTO)

The power take off (PTO) switch starts and stops the mower blades and some powered attachments.

1. If the engine is cold, allow the engine to warm up 5 to 10 minutes before engaging the PTO.
2. While seated in the seat, release the pressure on the traction control levers and place them in neutral.
3. Pull up on the PTO switch to engage it (Figure 23).



**Figure 23**

1. PTO switch

## Disengaging the PTO

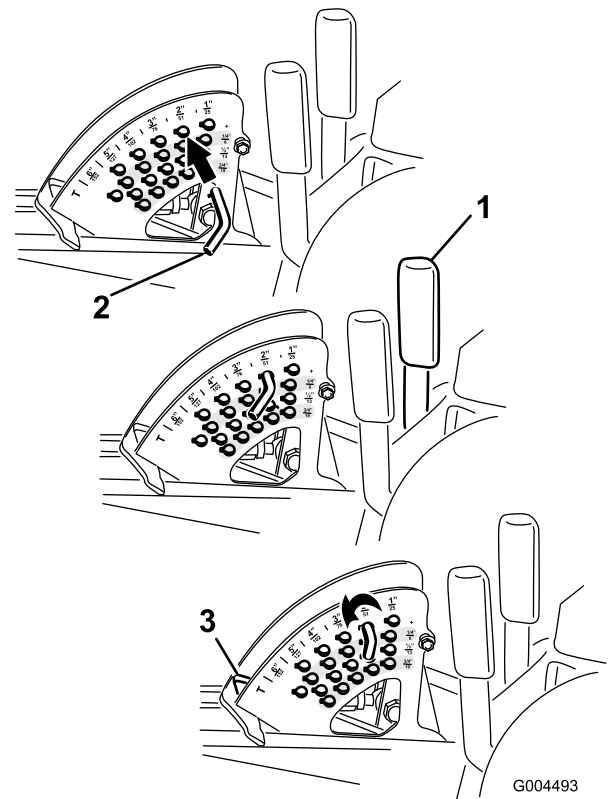
To disengage, push the PTO switch to the off position.

## Adjusting the Height-of-Cut

The height-of-cut is adjusted from 1 to 6 inches (2.5 to 15.8 cm) in 1/4 inch (6 mm) increments by relocating the stop pin into different hole locations.

1. With the engine running, pull back on the deck lift lever until the mower deck is fully raised and **release the lever immediately** (Figure 24).
2. To adjust, rotate the stop pin until the roll pin in it lines up with the slots in the holes in the height-of-cut bracket and remove it (Figure 24).
3. Select a hole in the height-of-cut bracket corresponding to the height-of-cut desired, insert the pin, and rotate it down to lock it in place (Figure 24).

**Note:** There are four rows of hole positions (Figure 24). The top row gives you the height of cut listed above the pin. The second row down gives you the height listed plus 1/4 inch (6 mm). The third row down gives you the height listed plus 1/2 inch (12 mm). The bottom row gives you the height listed plus 3/4 inch (18 mm). For the 6 inch (15.8 cm) position there is only one hole, located in the second row. This does not add 1/4 inch (6 mm) to the 6 inch (15.8 cm) position.



**Figure 24**

1. Deck lift lever
2. Stop pin
3. Height of cut stop

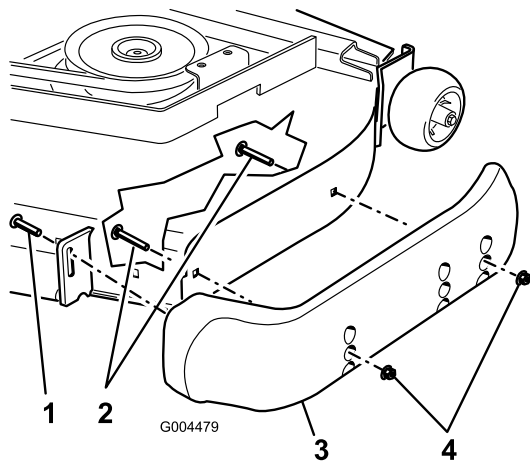
4. Adjust the anti-scalp rollers and skids as required.

## Adjusting the Skid(s)

Mount the skids in the lower position when operating in height of cuts higher than 2-1/2 inches (64 mm) and in the higher position when operating in height of cuts lower than 2-1/2 inches (64 mm).

**Note:** On Guardian® mowers, when the skids become worn, you can switch the skid to the opposite sides of the mower, flipping them over. This will allow you to use the skids longer before replacing them.

1. Disengage the PTO, move the motion control levers to the neutral locked position, and set the parking brake.
2. Move the throttle lever to the Slow position, stop the engine, remove the key, and wait for all moving parts to stop before leaving the operating position.
3. Loosen the screw at the front of each skid (2 skids on Guardian decks and 1 skid on side-discharge decks).



**Figure 25**

- |                     |         |
|---------------------|---------|
| 1. Screw            | 3. Skid |
| 2. Flange-head bolt | 4. Nut  |

- Remove the flange-head bolts and nuts from each skid.
- Move each skid to the desired position and secure them with the flange-head bolts and nuts.

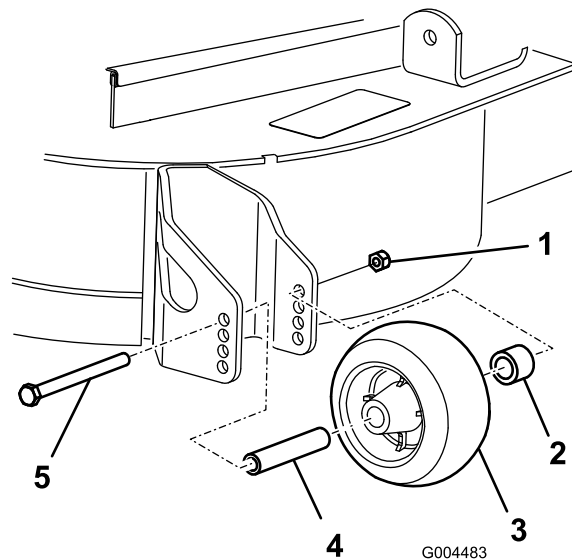
**Note:** Only use the top or center sets of holes to adjust the skids. The bottom holes are used when switching sides on a Guardian mower deck, at which time they become the top holes on the other side of the mower.

- Torque the screw at the front of each skid to 80 to 100 in-lb (9 to 11 N·m).

## Adjusting the Rear Anti-Scalp Rollers

Whenever you change the height-of-cut, adjust the height of the rear anti-scalp rollers.

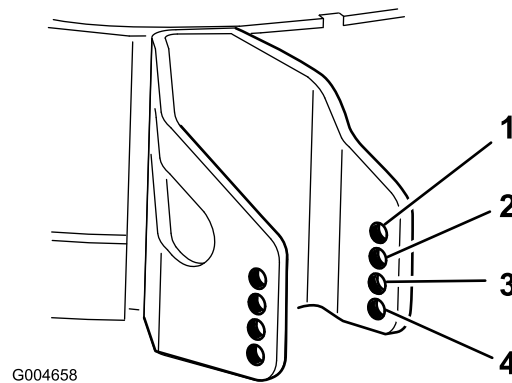
- Disengage the PTO, move the motion control levers to the neutral locked position, and set the parking brake.
- Move the throttle lever to the Slow position, stop the engine, remove the key, and wait for all moving parts to stop before leaving the operating position.
- After adjusting the height-of-cut, adjust the rollers by removing the flange nut, bushing, spacer, and bolt (Figure 26).



**Figure 26**

- |                      |           |
|----------------------|-----------|
| 1. Flange nut        | 4. Spacer |
| 2. Bushing           | 5. Bolt   |
| 3. Anti-scalp roller |           |

- Select a hole so the anti-scalp roller is positioned to the nearest corresponding height-of-cut desired (Figure 27).



**Figure 27**

- |                         |                                |
|-------------------------|--------------------------------|
| 1. 1-1/2 inches (38 mm) | 3. 2-1/2 inches (63 mm)        |
| 2. 2 inches (51 mm)     | 4. 3 inches (76 mm) and higher |

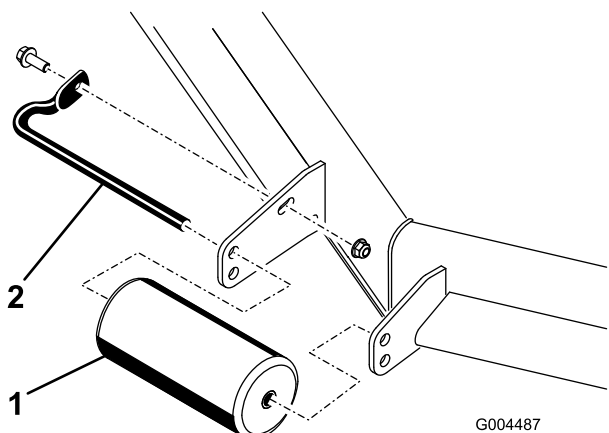
- Install the flange nut, bushing, spacer, and bolt. Torque to 40-45 ft-lb (54-61 N·m) (Figure 26).

## Adjusting the Rollers

Mount the rollers in the lower position when operating in height of cuts higher than 2-1/2 inches (64 mm) and in the higher position when operating in height of cuts lower than 2-1/2 inches (64 mm).

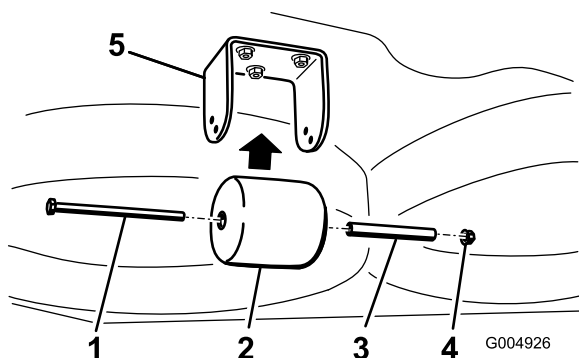
- Disengage the PTO, move the motion control levers to the neutral locked position and set the parking brake.

2. Move the throttle lever to the Slow position, stop the engine, remove the key, and wait for all moving parts to stop before leaving the operating position.
3. Raise the front of the machine and support it on jack stands.
4. Remove the fasteners securing each roller on your mower deck and move the rollers up or down as desired; refer to Figure 28 through Figure 32 as applicable for your mower.



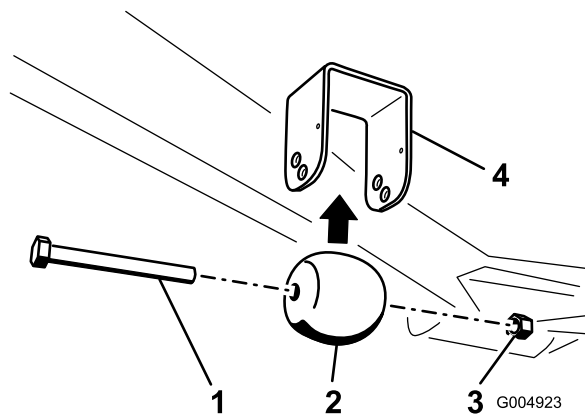
**Figure 28**  
All Mower Decks

1. Front roller
2. Roller shaft



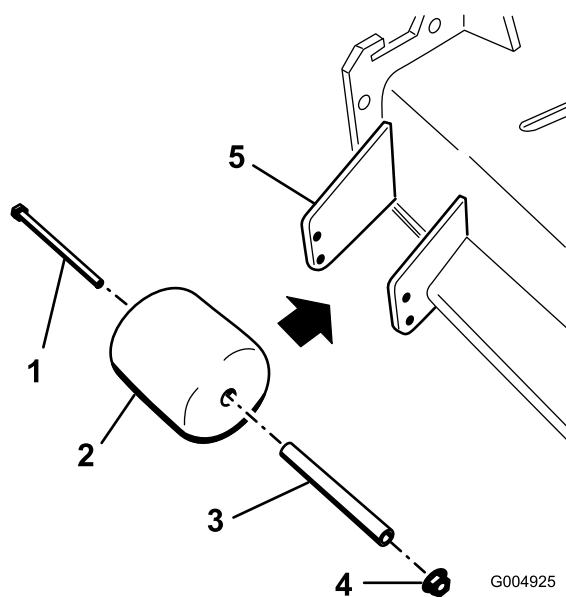
**Figure 29**  
Guardian Mower Decks Only

1. Bolt
2. Rear under-deck roller
3. Spacer
4. Nut
5. Bracket



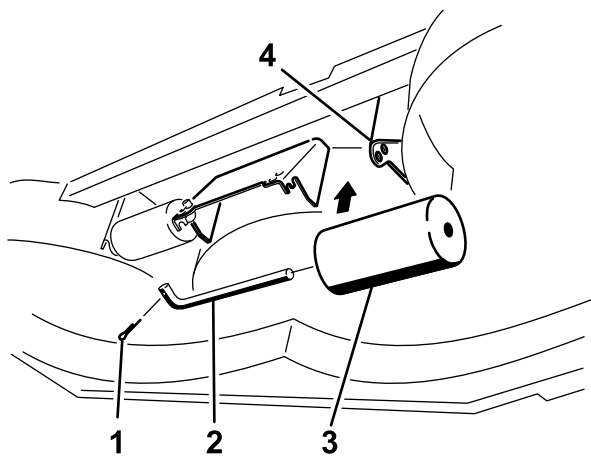
**Figure 30**  
Guardian Mower Decks Only

1. Bolt
2. Front under-deck roller
3. Nut
4. Bracket



**Figure 31**  
Side-discharge Mower Decks Only

1. Bolt
2. Chute-side roller
3. Spacer
4. Nut
5. Bracket



G004924

**Figure 32**

Side-discharge Mower Decks Only

- |                 |                          |
|-----------------|--------------------------|
| 1. Bolt         | 3. Under-deck roller (2) |
| 2. Roller shaft | 4. Bracket               |

- 
5. Install the fasteners as illustrated.

## The Safety Interlock System

### **⚠ CAUTION**

If the safety interlock switches are disconnected or damaged the machine could operate unexpectedly causing personal injury.

- Do not tamper with the interlock switches.
- Check the operation of the interlock switches daily and replace any damaged switches before operating the machine.

### Understanding the Safety Interlock System

The safety interlock system is designed to prevent the engine from starting unless:

- You are sitting on the seat or the parking brake is engaged.
- The power take off (PTO) is disengaged.
- The motion control levers are in the neutral locked position
- The engine temperature is below the maximum operating temperature.

The safety interlock system also is designed to stop the engine when the traction controls are moved from the neutral locked position with the parking brake engaged. If you rise from the seat when the PTO is engaged there is a 1 second delay and then the engine stops.

## Testing the Safety Interlock System

**Service Interval:** Before each use or daily

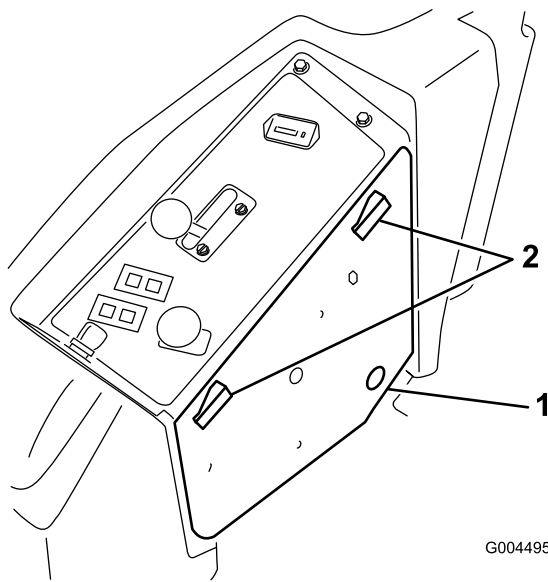
Test the safety interlock system before you use the machine each time. If the safety system does not operate as described below, have an Authorized Service Dealer repair the safety system immediately.

1. Sitting on the seat, engage the parking brake and move the PTO to on. Try starting the engine; the engine should not crank.
2. Sitting on the seat, engage the parking brake and move the PTO to off. Move either motion control lever (out of neutral locked position). Try starting the engine; the engine should not crank. Repeat for other control lever.
3. Sitting on the seat, engage the parking brake, move the PTO switch to off and move the motion control levers to the neutral locked position. Now start the engine. While the engine is running, release the parking brake, engage the PTO and rise slightly from the seat; the engine should stop within 2 seconds.
4. Without an operator on the seat, engage the parking brake, move the PTO switch to off and move the motion control levers to the neutral locked position. Now start the engine. While the engine is running, center either motion control; the engine should stop within 2 seconds. Repeat for the other motion control.
5. Without an operator on the seat, disengage the parking brake, move the PTO switch to off, and move the motion control levers to the neutral locked position. Try starting the engine; the engine should not crank.

### Using the SCM to Diagnose System Problems

The machine is equipped with a standard control module (SCM) monitoring system that tracks the function of various key systems. The SCM is located under the right control panel. Access it through the side panel cover (Figure 33). To open the side panel cover, release the 2 latches and pull out on it.

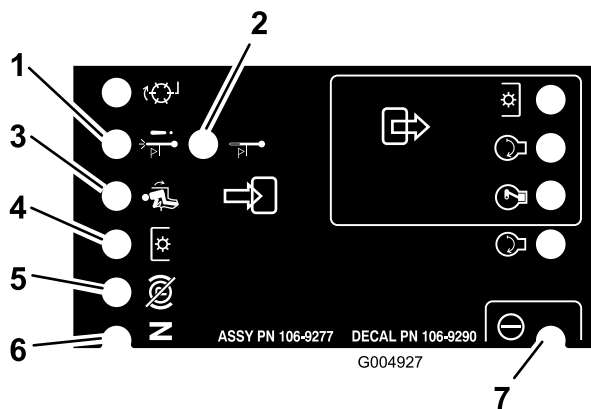




**Figure 33**

1. Side panel cover
2. Latches

On the face of the SCM are 11 LEDs that illuminate to indicate various system conditions. Seven of these lights can be used by the operator for system diagnosis. Refer to Figure 34 for a description of what each light means. For details on using the rest of the SCM functions, refer to the *Service Manual*, available through your Authorized Toro Distributor.



**Figure 34**

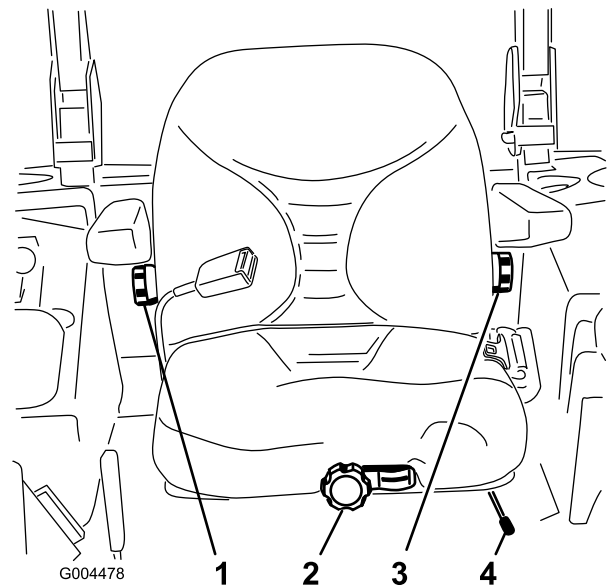
1. High temperature shutdown—the engine temperature has exceeded safe levels and the engine has been shut down. Check the cooling system.
2. High temperature warning—the engine temperature is approaching unsafe levels and the mower deck has been shut down. Check the cooling system.
3. Operator is in the seat
4. The PTO is On
5. The parking brake is not engaged
6. Controls are in Neutral
7. The SCM is receiving power and is operational

## Positioning the Seat

### Changing the Seat Position

The seat can move forward and backward. Position the seat where you have the best control of the machine and are most comfortable.

1. To adjust, move the lever sideways to unlock the seat (Figure 35).



**Figure 35**

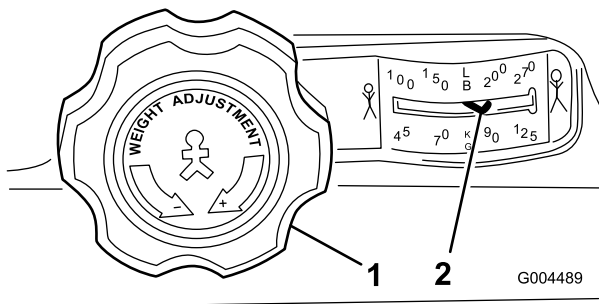
1. Back rest knob
2. Seat suspension knob
3. Lumbar support adjustment knob
4. Seat position adjustment lever

2. Slide the seat to the desired position and release lever to lock in position.
3. Verify that the seat has locked into place by attempting to move it back and forth.

### Changing the Seat Suspension

The seat can be adjusted to provide a smooth and comfortable ride. Position the seat where you are most comfortable.

Without sitting on the seat, turn the knob in front either direction to provide the best comfort (Figure 35).



**Figure 36**

1. Seat suspension knob
2. Operator weight setting

## Changing the Back Position

The back of the seat can be adjusted to provide a comfortable ride. Position the back of the seat where it is most comfortable.

To adjust it, turn the knob, under the right-side arm rest, in either direction to provide the best comfort (Figure 35).

## Changing the Lumbar Support

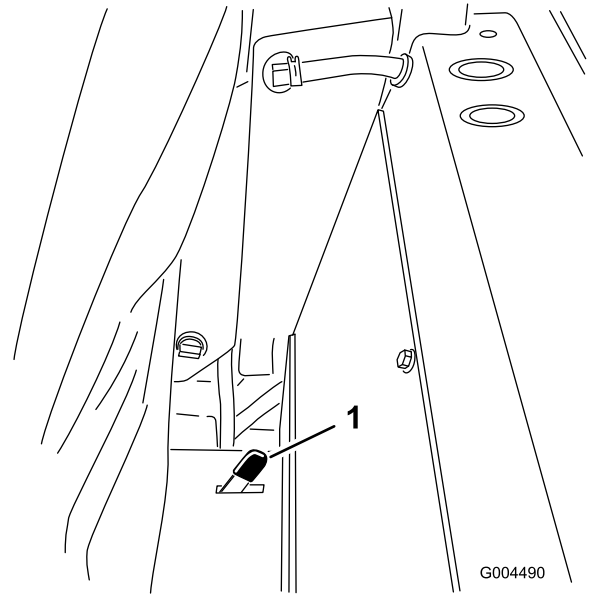
The back of the seat can be adjusted to provide a customized lumbar support for your lower back.

To adjust it, turn the knob, under the left-side arm rest, in either direction to provide the best comfort (Figure 35).

## Unlatching the Seat

To access the hydraulic and other systems under the seat, you need to unlatch the seat and swing it forward.

1. Use the seat position adjustment lever to slide the seat all the way forward.
2. Push one of the seat latches, located behind and to the sides of the seat, rearward to unlatch the seat and pull forward on the top of the seat (Figure 37).



**Figure 37**

1. Seat latch

## Pushing the Machine by Hand

If the machine breaks, runs out of fuel, etc. you may need to push it. To do so, you first need to open the hydraulic by-pass valves.

**Important:** Always push the machine by hand. Never tow the machine because hydraulic damage may occur.

## Pushing the Machine

1. Disengage the power take off (PTO) and turn the ignition key to off. Move the levers to the neutral locked position and apply the parking brake. Remove the key.
2. Lift the seat.
3. Rotate each by-pass valve counterclockwise 1 turn (Figure 38).

This allows hydraulic fluid to by-pass the pump enabling the wheels to turn .

**Important:** Do not rotate the by-pass valves more than 1 turn. This prevents valves from coming out of the body and causing fluid to run out.

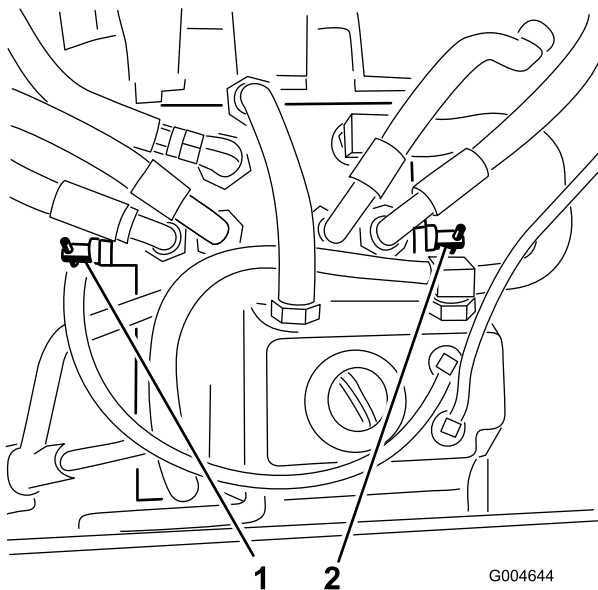


Figure 38

1. Right by-pass valve
2. Left by-pass valve

4. Disengage the parking brake before pushing.

## Changing to Machine Operation

Rotate each by-pass valve clockwise 1 turn and hand tighten them (torque of approximately 71 in-lb (8 N·m)) (Figure 38).

**Note:** Do not over tighten the by-pass valves.

The machine will not drive unless by-pass valves are turned in.

## Loading Machines

Use extreme caution when loading units on trailers or trucks. One full width ramp that is wide enough to extend beyond the rear tires is recommended instead of individual ramps for each side of the unit (Figure 39). The lower rear section of the tractor frame extends back between the rear wheels and serves as a stop for tipping backward. Having a full width ramp provides a surface for the frame members to contact if the unit starts to tip backward. If it is not possible to use one full width ramp, use enough individual ramps to simulate a full width continuous ramp.

The ramp should be long enough so that the angles do not exceed 15 degrees (Figure 39). A steeper angle may cause mower components to get caught as the unit moves from ramp to trailer or truck. Steeper angles may also cause the unit to tip backward. If loading on or near a slope, position the trailer or truck so it is on the down side of the slope and the ramp extends up the

slope. This will minimize the ramp angle. The trailer or truck should be as level as possible.

**Important:** Do not attempt to turn the unit while on the ramp; you may lose control and drive off the side.

Avoid sudden acceleration when driving up a ramp and sudden deceleration when backing down a ramp. Both maneuvers can cause the unit to tip backward.

### ⚠ WARNING

Loading a unit onto a trailer or truck increases the possibility of backward tip-over and could cause serious injury or death.

- Use extreme caution when operating a unit on a ramp.
- Use only a single, full width ramp; Do not use individual ramps for each side of the unit.
- If individual ramps must be used, use enough ramps to create an unbroken ramp surface wider than the unit.
- Do not exceed a 15 degree angle between ramp and ground or between ramp and trailer or truck.
- Avoid sudden acceleration while driving unit up a ramp to avoid tipping backward.
- Avoid sudden deceleration while backing unit down a ramp to avoid tipping backward.

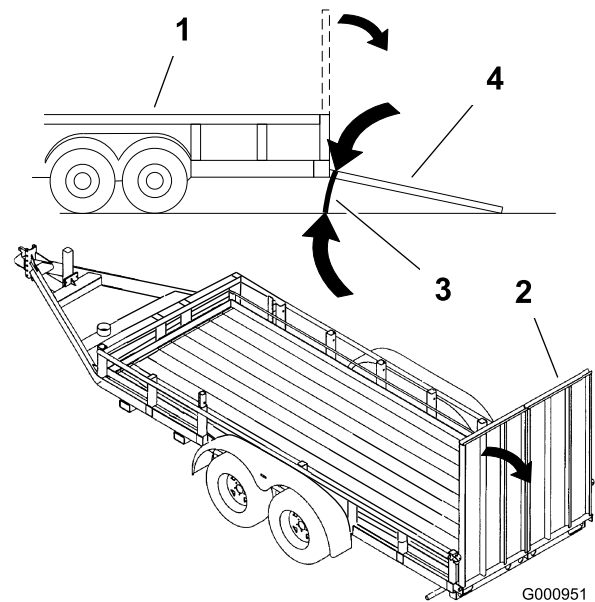


Figure 39

1. Trailer
2. Full width ramp
3. Not greater than 15 degrees
4. Full width ramp—side view

# Transporting Machines

## ⚠ WARNING

Driving on the street or roadway without turn signals, lights, reflective markings, or a slow moving vehicle emblem is dangerous and can lead to accidents causing personal injury.

Do not drive machine on a public street or roadway without signs, lights, and/or markings required by local regulations.

Use a heavy-duty trailer or truck to transport the machine. Ensure that the trailer or truck has all necessary lighting and marking as required by law. Please carefully read all the safety instructions. Knowing this information could help you or bystanders avoid injury.

To transport the machine:

- Ensure that your vehicle, hitch, safety chains, and trailer are adequate for the load you are pulling and that they meet all local traffic regulations for your area.
- Lock the brake and block the wheels.
- Securely fasten the machine to the trailer or truck with straps, chains, cable, or ropes as required by local traffic regulations in your area (Figure 40).

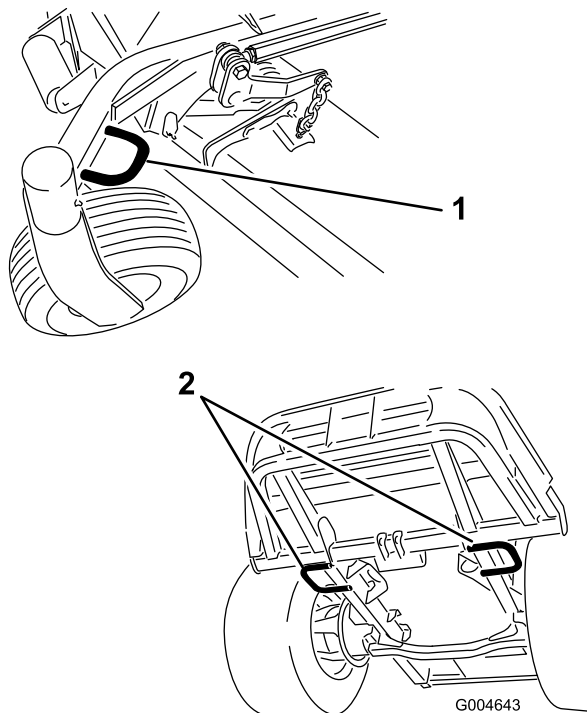


Figure 40

1. Front tie-down (left side shown)
2. Rear tie-downs

# Operating Tips

## Fast Throttle Setting/Ground Speed

To maintain enough power for the machine and deck while mowing, operate the engine at the fast throttle position and adjust your ground speed for conditions. A good rule to follow is: decrease ground speed as the load on the cutting blades increases; and increase ground speed as load on the blades decreases.

## Mowing Direction

Alternate mowing direction to avoid making ruts in the turf over time. This also helps disperse clippings which enhances decomposition and fertilization.

## Cutting Speed

To improve cut quality, use a slower ground speed in certain conditions.

## Avoid Cutting Too Low

If the cutting width of the mower is wider than the mower you previously used, raise the cutting height to ensure that uneven turf is not cut too short.

## Select the Proper Height-of-Cut Setting to Suit Conditions

Remove approximately 1 inch (25 mm) or no more than 1/3 of the grass blade when cutting. In exceptionally lush and dense grass, you may have to slow down the forward speed and/or raise the height-of-cut to the next higher setting.

**Important:** If cutting more than 1/3 of the grass blade off, or in sparse long grass or dry conditions, the use of flat sail blades is recommended to reduce air-borne chaff, debris, and deck drive component strain.

## Long Grass

If the grass is ever allowed to grow slightly longer than normal, or if it contains a high degree of moisture, raise the cutting height higher than usual and cut the grass at this setting. Then cut the grass again using the lower, normal setting.

## Keep the Mower Clean

Clean clippings and dirt from the underside of the mower after each use. If grass and dirt build up inside the mower, cutting quality will eventually become unsatisfactory.

To reduce the risk of fire hazard, keep the engine, muffler, battery compartment, parking brake, cutting units, and fuel storage compartment free of grass, leaves, or excessive grease. Clean up any spilled oil or fuel.

## **Blade Maintenance**

Maintain a sharp blade throughout the cutting season because a sharp blade cuts cleanly without tearing or shredding the grass blades. Tearing and shredding turns grass brown at the edges, which slows growth and increases the chance of disease. Check the blades daily for sharpness, and for any wear or damage. Sharpen the blades as necessary. If a blade is damaged or worn, replace it immediately with a genuine Toro replacement blade. Refer to Servicing the Cutting Blades.

# Maintenance

**Note:** Determine the left and right sides of the machine from the normal operating position.

## ***Recommended Maintenance Schedule(s)***

<b>Maintenance Service Interval</b>	<b>Maintenance Procedure</b>
After the first 10 hours	<ul style="list-style-type: none"> <li>• Check the alternator belt tension.</li> <li>• Torque the frame mounting bolts.</li> <li>• Torque wheel lug nuts.</li> </ul>
After the first 50 hours	<ul style="list-style-type: none"> <li>• Change the mower deck gear box lubricant</li> <li>• Change the engine oil and filter.</li> </ul>
After the first 200 hours	<ul style="list-style-type: none"> <li>• Change the hydraulic oil and filter.</li> </ul>
Before each use or daily	<ul style="list-style-type: none"> <li>• Test the safety system.</li> <li>• Check the engine oil level.</li> <li>• Check the engine coolant level.</li> <li>• Clean the radiator with compressed air (do not use water)</li> <li>• Check the hydraulic fluid level.</li> <li>• Check the mower blades.</li> <li>• Clean the mower deck.</li> </ul>
Every 50 hours	<ul style="list-style-type: none"> <li>• Grease the bearing and bushing grease fittings.</li> <li>• Check battery cable connections.</li> <li>• Check the tire pressure.</li> <li>• Check the condition of the blade drive belts on the mower deck.</li> </ul>
Every 150 hours	<ul style="list-style-type: none"> <li>• Check the lubricant in the mower deck gear box.</li> <li>• Change the engine oil and filter.</li> </ul>
Every 200 hours	<ul style="list-style-type: none"> <li>• Inspect cooling system hoses and seals. Replace them if cracked or torn.</li> <li>• Check the alternator belt tension.</li> <li>• Torque wheel lug nuts.</li> </ul>
Every 400 hours	<ul style="list-style-type: none"> <li>• Change the mower deck gear box lubricant</li> <li>• Service the air cleaner.</li> <li>• Replace the fuel filter canister.</li> <li>• Check the fuel lines and connections.</li> </ul>
Every 800 hours	<ul style="list-style-type: none"> <li>• Change the hydraulic oil and filter.</li> <li>• Inspect engine valve clearance. Refer to your Engine Operator's Manual.</li> </ul>
Every 1,500 hours	<ul style="list-style-type: none"> <li>• Replace moving hoses</li> </ul>
Every 2 years	<ul style="list-style-type: none"> <li>• Drain and clean the fuel tank.</li> <li>• Flush and replace cooling system fluid.</li> </ul>

**Important:** Refer to your *Engine Operator's Manual* for additional maintenance procedures. A detailed Service Manual is also available for purchase from your Authorized Toro Distributor.

# Daily Maintenance Checklist

Duplicate this page for routine use.

Maintenance Check Item	For the week of:						
	Mon.	Tues.	Wed.	Thurs.	Fri.	Sat.	Sun.
Check Safety Interlock Operation							
Check Grass Deflector in Down Position (if applicable)							
Check Parking Brake Operation							
Check Fuel Level							
Check Hydraulic Oil Level							
Check Engine Oil Level							
Check Cooling System Fluid Level							
Check Drain Water/Fuel Separator							
Check Air Filter Restriction Indicator <sup>3</sup>							
Check Radiator & Screen for Debris							
Check Unusual Engine Noises <sup>1</sup>							
Check Unusual Operating Noises							
Check Hydraulic Hoses for Damage							
Check Fluid Leaks							
Check Tire Pressure							
Check Instrument Operation							
Check Condition of Blades							
Lubricate All Grease Fittings <sup>2</sup>							
Touch-up Damaged Paint							

1. Check glow plug and injector nozzles, if hard starting, excess smoke or rough running is noted.
2. Immediately after every washing, regardless of the interval listed.
3. If indicator shows red

Notation for Areas of Concern		
Inspection performed by:		
Item	Date	Information

## ⚠ CAUTION

If you leave the key in the ignition switch, someone could accidentally start the engine and seriously injure you or other bystanders.

Remove the key from the ignition before you do any maintenance.

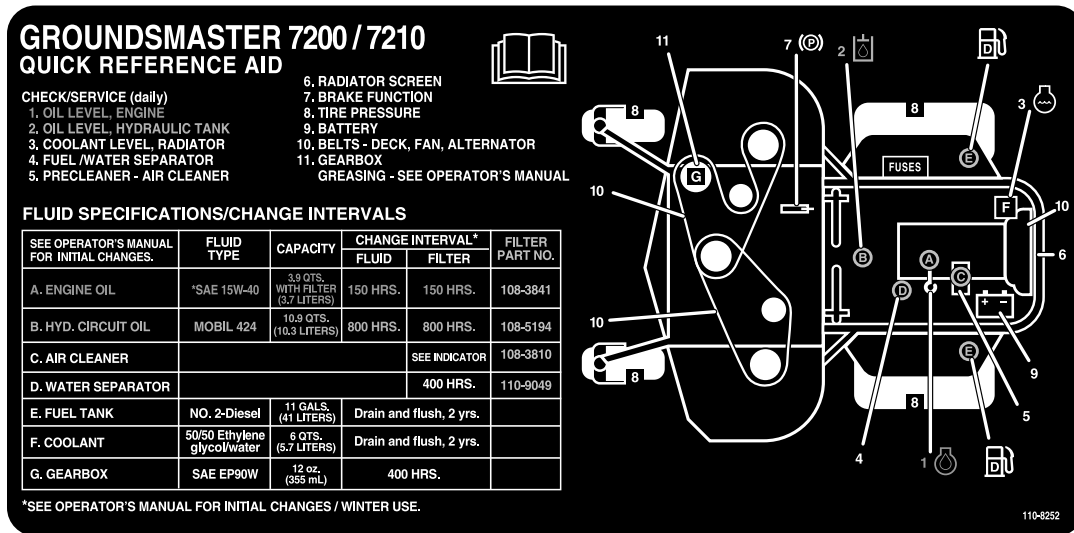


Figure 41  
Service Interval Chart

## Premaintenance Procedures

**Important:** The fasteners on the covers of this machine are designed to remain on the cover after removal. Loosen all of the fasteners on each cover a few turns so that the cover is loose but still attached, then go back and loosen them until the cover comes free. This will prevent you from accidentally stripping the bolts free of the retainers.

## Lubrication

### Greasing the Bearings and Bushings

**Service Interval:** Every 50 hours

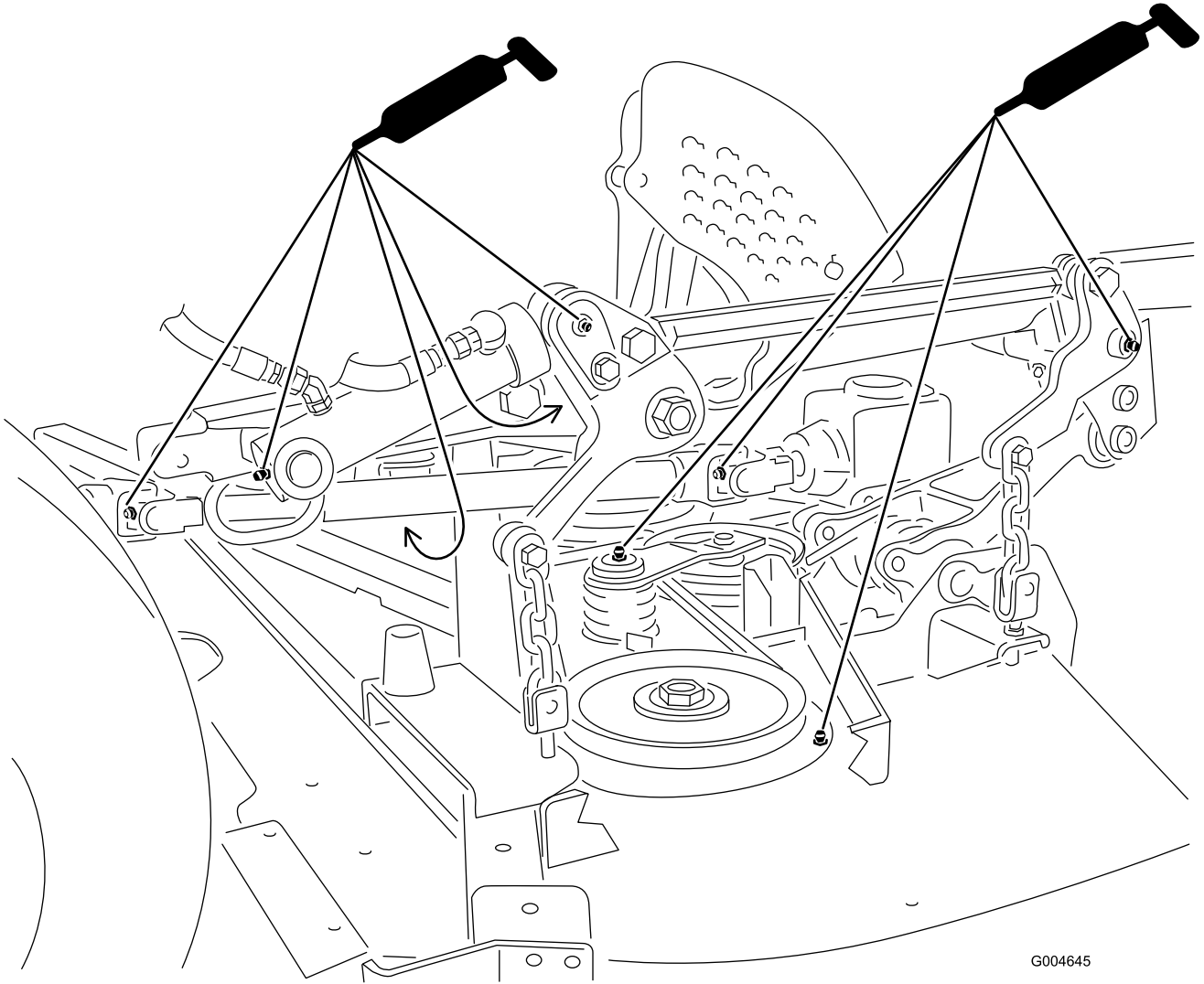
The machine has grease fittings that must be lubricated regularly with No. 2 General Purpose Lithium Base Grease. If the machine is operated under normal conditions, lubricate all bearings and bushings after every 50 hours of operation. Bearings and bushings must be lubricated daily when operating conditions are extremely dusty and dirty. Dusty and dirty operating conditions could cause dirt to get into the bearings and bushings, resulting in accelerated wear. Lubricate the grease fittings immediately after every washing, regardless of interval specified.

1. Wipe the grease fittings clean so foreign matter cannot be forced into the bearing or bushing.
2. Pump grease into the fittings.
3. Wipe off excess grease.

Figure 42 and Figure 43 illustrate the locations of the grease fittings.



**Important:** The fittings on the axles of the caster wheels are not illustrated. Ensure that you grease these fittings as well.



G004645

**Figure 42**

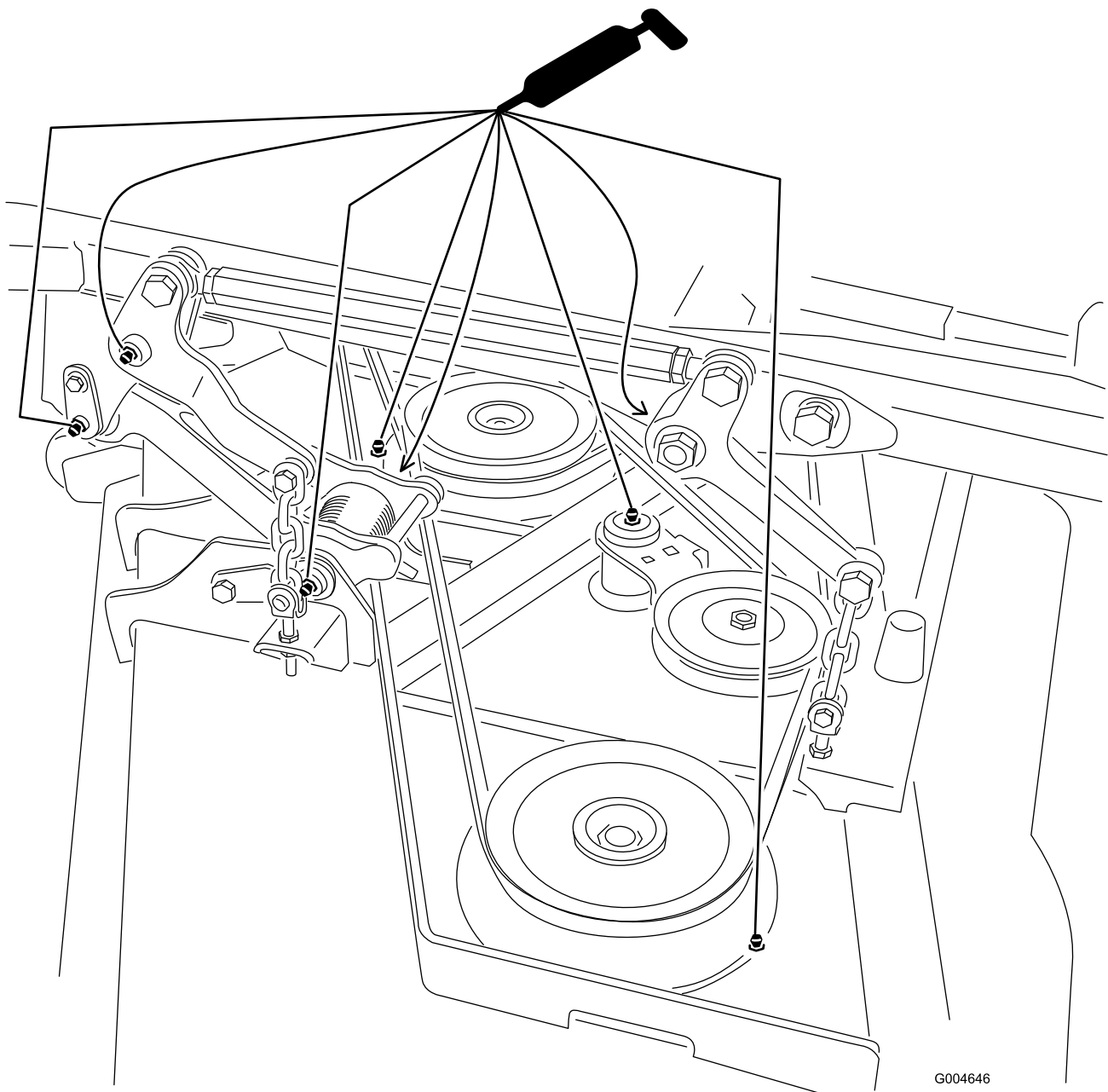


Figure 43

G004646

**Note:** Bearing life can be negatively affected by improper wash down procedures. Do not wash down the unit when it is still hot and avoid directing high-pressure or high volume spray at the bearings or seals.

## Servicing the Mower Deck Gear Box Lubricant

The gear box is designed to operate with SAE 80-90 gear lube. Although the gear box is shipped with lubricant from the factory, check the level before operating the cutting unit for the first time and every 150 operating hours thereafter. Change the lubricant in the gear box every 400 operating hours.

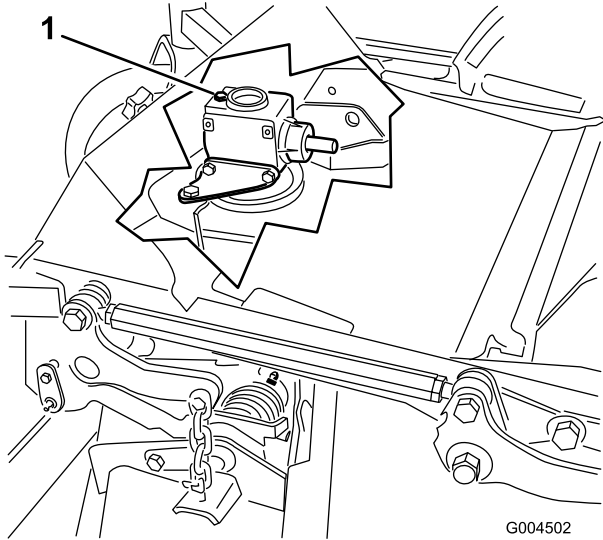
## Checking the Mower Deck Gear Box Lubricant

**Service Interval:** Every 150 hours

1. Position the machine and cutting unit on a level surface.
2. Lower the mower deck to the 1 inch (2.5 cm) height-of-cut.
3. Disengage the PTO, move the motion control levers to the neutral locked position and set the parking brake.
4. Move the throttle lever to the Slow position, stop the engine, remove the key, and wait for all moving parts to stop before leaving the operating position.

5. Lift the footrest, exposing the top of the mower deck.
6. Remove the dipstick/fill plug from the top of the gear box (Figure 44) and make sure that the lubricant is between the marks on the dipstick.
8. Replace the drain plug.
9. Add enough lubricant, approximately 12 oz. (283 ml), until the level is between the marks on the dipstick.

**Note:** Do not over fill or the gearbox may be damaged.



**Figure 44**

1. Fill plug and dipstick

7. If the lubricant level is low, add enough lubricant until the level is between the marks on the dipstick.

**Note:** Do not over fill or the gearbox may be damaged.

## Changing the Mower Deck Gear Box Lubricant

**Service Interval:** After the first 50 hours  
Every 400 hours

1. Position the machine and cutting unit on a level surface.
2. Lower the mower deck to the 1 inch (2.5 cm) height-of-cut.
3. Disengage the PTO, move the motion control levers to the neutral locked position and set the parking brake.
4. Move the throttle lever to the Slow position, stop the engine, remove the key, and wait for all moving parts to stop before leaving the operating position.
5. Lift the footrest, exposing the top of the mower deck.
6. Remove the dipstick/fill plug from the top of the gear box (Figure 44).
7. Place a funnel and drain pan under the drain plug located under the front of the gear box and remove the plug, draining the lubricant into the pan.

# Engine Maintenance

## Air Cleaner Maintenance

- Check the air cleaner body for damage which could possibly cause an air leak. Replace a damaged air cleaner body. Check the whole clean air intake system for leaks, damage, or loose hose clamps.
- Service the air cleaner filter when the air cleaner indicator (Figure 45) shows red or every 400 hours (more frequently in extremely dusty or dirty conditions). Do not over service the air filter.

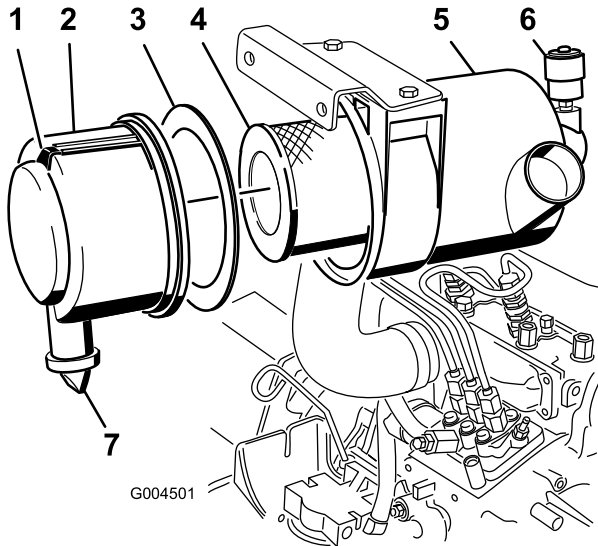


Figure 45

- |                      |                          |
|----------------------|--------------------------|
| 1. Air cleaner cover | 5. Air cleaner indicator |
| 2. Gasket            | 6. Air cleaner latch     |
| 3. Filter            | 7. Rubber outlet valve   |
| 4. Air cleaner body  |                          |

- Be sure the cover is seated correctly and seals with the air cleaner body.

## Servicing the Air Cleaner

**Service Interval:** Every 400 hours

1. Pull the latch outward and rotate the air cleaner cover counter-clockwise (Figure 45).
2. Remove the cover from the air cleaner body (Figure 45).
3. Before removing the filter, use low pressure air (40 psi, clean and dry) to help remove large accumulations of debris packed between outside of primary filter and the canister.

This cleaning process prevents debris from migrating into the intake when the primary filter is removed.

**Important:** Avoid using high pressure air which could force dirt through the filter into the intake tract.

4. Remove and replace the primary filter (Figure 45).

**Important:** Do not clean the used element to avoid damage to the filter media.

5. Inspect the new filter for shipping damage, checking the sealing end of the filter and the body.

**Important:** Do not use a damaged element.

6. Ensure that the foam gasket is in place in the cover and that it is not torn or damaged (Figure 45). If it is damaged, replace it.
7. Insert the new filter by applying pressure to the outer rim of the element to seat it in the canister.

**Important:** Do not apply pressure to the flexible center of the filter.

8. Clean the dirt ejection port located in the removable cover, as follows:
  - A. Remove the rubber outlet valve from the cover (Figure 45).
  - B. Clean the cavity.
  - C. Replace the outlet valve.
9. Install the cover orienting the rubber outlet valve in a downward position—between approximately 5:00 to 7:00 when viewed from the end.
10. Reset the indicator (Figure 45) if showing red.

## Servicing the Engine Oil

### Checking the Engine Oil Level

**Service Interval:** Before each use or daily

The engine is shipped with oil in the crankcase; however, the oil level must be checked before and after the engine is first started. Check oil level before each day's operation or each time machine is used.

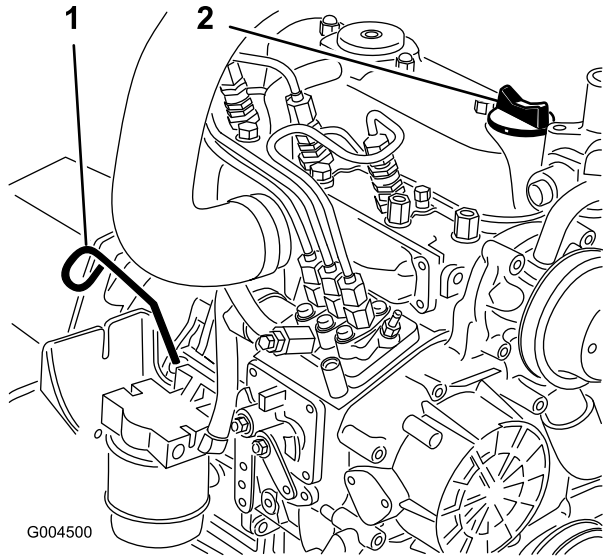
The crankcase capacity is approximately 4 qt. (3.8 l) with the filter. Use high-quality engine oil that meets the following specifications:

- API Classification Level Required: CH-4, CI-4 or higher.
- Preferred oil: SAE 15W-40 (above 0°F (-17°C))
- Alternate oil: SAE 10W-30 or 5W-30 (all temperatures)

**Note:** Toro Premium Engine oil is available from your distributor in either 15W-40 or 10W-30 viscosity. See the parts catalog for part numbers.

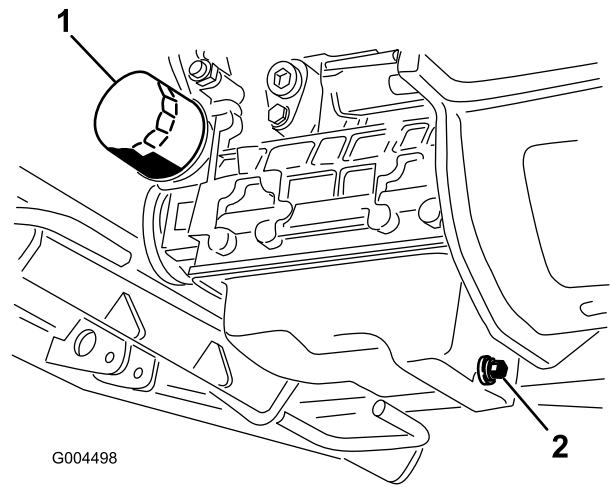
1. Park the machine on a level surface, lower the mower deck, move the throttle lever to the Slow position, stop the engine, and remove the key from the ignition switch. Open the hood.
2. Remove the dipstick (Figure 46), wipe it clean, and install the dipstick. Remove the dipstick and check the oil level.

The oil level should be up to the Full mark on the dipstick.



**Figure 46**

1. Dipstick
2. Oil fill



**Figure 47**

1. Oil filter
2. Drain plug

4. Clean the area around the drain plug.
5. Remove the drain plug and allow the oil to flow into drain pan.
6. Remove and replace the oil filter (Figure 47).
7. After the oil is drained, install the drain plug and wipe up any oil that is spilled.
8. Fill the crankcase with oil; refer to Checking the Engine Oil Level.

3. If the oil level is below the Full mark, remove the fill cap (Figure 46) and add oil until the level reaches the Full mark on the dipstick.

**Important:** Do not overfill.

**Note:** Use a clean funnel to prevent spills.

4. Install the oil fill cap and close the hood.

## Changing the Engine Oil And Filter

**Service Interval:** After the first 50 hours

Every 150 hours

Change the oil and filter initially after first 50 hours of operation and then every 150 hours of operation thereafter. If possible, run the engine just before changing the oil because warm oil flows better and carries more contaminants than cold oil.

1. Position the machine on a level surface.
2. Open the hood.
3. Set a drain pan under the oil pan and in line with the drain plug (Figure 47).

# Fuel System Maintenance

**Note:** Refer to Adding Fuel for proper fuel recommendations.

## **▲ DANGER**

Under certain conditions, diesel fuel and fuel vapors are highly flammable and explosive. A fire or explosion from fuel can burn you and others and can cause property damage.

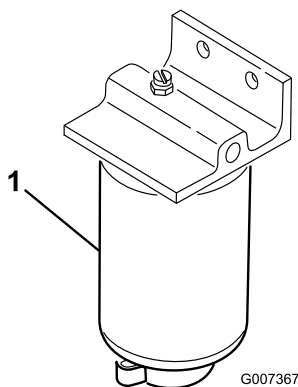
- Use a funnel and fill the fuel tank outdoors, in an open area, when the engine is off and is cold. Wipe up any fuel that spills.
- Do not fill the fuel tank completely full. Add fuel to the fuel tank until the level is to the bottom of the filler neck.
- Never smoke when handling fuel, and stay away from an open flame or where fuel fumes may be ignited by a spark.
- Store fuel in a clean, safety-approved container and keep the cap in place.

## Servicing the Water Separator

**Service Interval:** Every 400 hours

Drain water or other contaminants from water separator (Figure 48) daily. Replace filter canister after every 400 hours of operation.

1. Place a clean container under the fuel filter.
2. Loosen the drain plug on the bottom of the filter canister.



**Figure 48**

1. Water separator filter canister

3. Clean the area where the filter canister mounts.
4. Remove the filter canister and clean the mounting surface.

5. Lubricate the gasket on the filter canister with clean oil.
6. Install the filter canister by hand until the gasket contacts mounting surface, then rotate it an additional 1/2 turn.
7. Tighten the drain plug on the bottom of the filter canister.

## Cleaning the Fuel Tank

**Service Interval:** Every 2 years

Drain and clean fuel tank every 2 years. Also, remove and clean the in-line strainers after draining the tank. Use clean diesel fuel to flush out the tank.

**Important:** Drain and clean the tank if the fuel system becomes contaminated or if the machine is to be stored for an extended period.

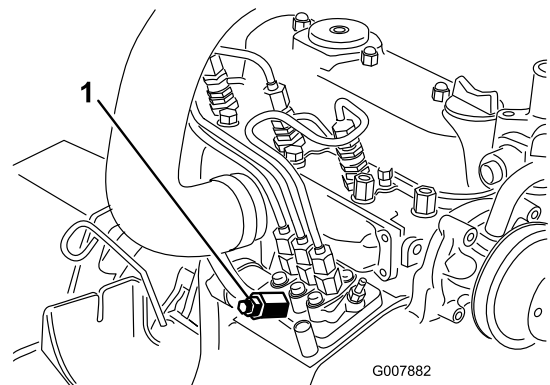
## Fuel Lines and Connections

**Service Interval:** Every 400 hours

Check the fuel lines and connections every 400 hours or yearly, whichever comes first. Inspect them for deterioration, damage, chaffing, or loose connections.

## Bleeding the Fuel System

1. Park the machine on a level surface. Ensure that the fuel tank is at least half full.
2. Unlatch and raise the hood.
3. Place a rag under the air bleed screw on the fuel injection pump and open it (Figure 49).



**Figure 49**

1. Fuel injection pump bleed screw

4. Turn the key in the ignition switch to the On position.

The electric fuel pump will begin operation, thereby forcing air out around the air bleed screw.

### **⚠ CAUTION**

**The engine may start during this procedure. Moving fans and belts in a running engine can severely injure you or bystanders.**

**Keep hands, fingers, loose clothing/jewelry, and hair away from the engine fan and belt during this procedure.**

5. Leave the key in the On position until a solid stream of fuel flows out around the screw.
6. Tighten the screw and turn key to the Off position.

**Note:** Normally, the engine should start after above bleeding procedures are followed. However, if engine does not start, air may be trapped between injection pump and injectors; refer to Bleeding Air From the Injectors.

### **⚠ CAUTION**

**The engine may start during this procedure. Moving fans and belts in a running engine can severely injure you or bystanders.**

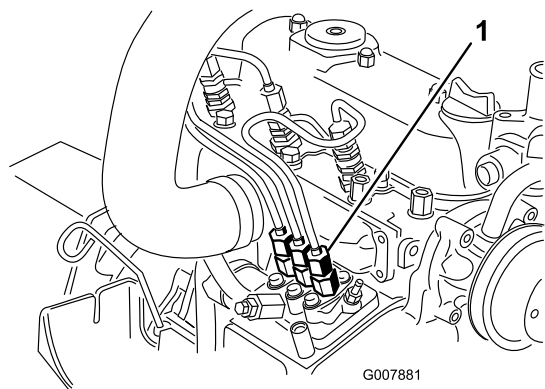
**Keep hands, fingers, loose clothing/jewelry, and hair away from the engine fan and belt during this procedure.**

4. Tighten the pipe connector securely when it attains a solid flow.
5. Turn the key to the Off position.
6. Repeat this procedure for the remaining nozzles.

## Bleeding Air From the Injectors

**Note:** This procedure should be used only if the fuel system has been purged of air through normal priming procedures and engine will not start; refer to Bleeding the Fuel System.

1. Place a rag under the pipe connection coming from the injection pump to the No. 1 injector nozzle as illustrated in Figure 50.



**Figure 50**

1. Pipe connection from the injection pump to the No. 1 injector nozzle
- 
2. Move the throttle to the Fast position.
  3. Turn the ignition key the Start position and watch the fuel flow around the connector.

# Electrical System Maintenance

**Important:** Whenever working with the electrical system, always disconnect the battery cables, negative (-) cable first, to prevent possible wiring damage from short-outs.

## Servicing the Battery

Service Interval: Every 50 hours

### WARNING

#### CALIFORNIA Proposition 65 Warning

Battery posts, terminals, and related accessories contain lead and lead compounds, chemicals known to the State of California to cause cancer and reproductive harm.  
Wash hands after handling.

Keep the top of the battery clean. If you store the machine in a location where temperatures are extremely high, the battery will run down more rapidly than if the machine is stored in a location where temperatures are cool.

Keep the top of the battery clean by washing it periodically with a brush dipped in ammonia or bicarbonate of soda solution. Flush the top surface with water after cleaning it. Do not remove the fill caps while cleaning the battery.

The battery cables must be tight on the terminals to provide good electrical contact.

If corrosion occurs at the terminals, disconnect the cables, negative (-) cable first, and scrape the clamps and terminals separately. Reconnect the cables, positive (+) cable first, and coat the terminals with petroleum jelly.

### WARNING

Battery terminals or metal tools could short against metal machine components causing sparks. Sparks can cause the battery gasses to explode, resulting in personal injury.

- When removing or installing the battery, do not allow the battery terminals to touch any metal parts of the machine.
- Do not allow metal tools to short between the battery terminals and metal parts of the machine.

### WARNING

Incorrect battery cable routing could damage the machine and cables causing sparks. Sparks can cause the battery gasses to explode, resulting in personal injury.

- Always disconnect the negative (black) battery cable before disconnecting the positive (red) cable.
- Always connect the positive (red) battery cable before connecting the negative (black) cable.

## Storing the Battery

If the machine will be stored more than 30 days, remove the battery and charge it fully. Either store it on a shelf or on the machine. Leave the cables disconnected if it is stored on the machine. Store the battery in a cool atmosphere to avoid quick deterioration of the charge in the battery. To prevent the battery from freezing, make sure it is fully charged. The specific gravity of a fully charged battery is 1.265-1.299.

## Checking the Fuses

The fuses are located under the control panel. Access them through the side panel cover (Figure 51). To open the side panel cover, release the 2 latches and pull out on it.

If the machine stops or has other electrical system issues, check the fuses. Grasp each fuse in turn and remove them one at a time, checking to see if any are blown. If you need to replace a fuse, always use the **same type and amperage rated fuse** as the one you are replacing, **otherwise you could damage the electrical system** (refer to the decal next to the fuses (Figure 52) for a diagram of each fuse and its amperage).

**Note:** If a fuse blows frequently, you probably have a short in the electrical system and should have it serviced by a qualified service technician.



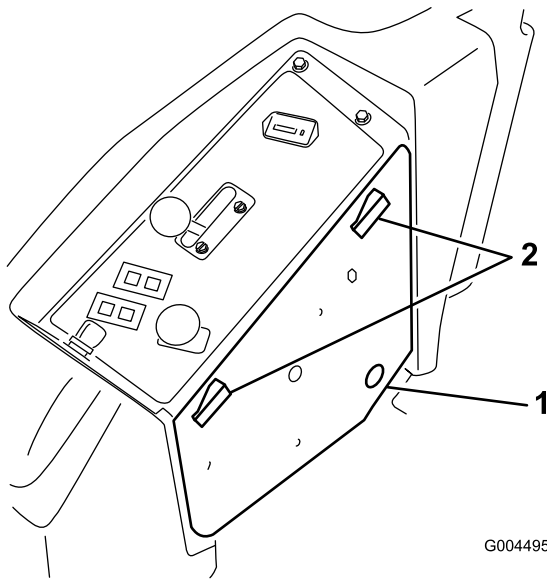
# Drive System Maintenance

## Checking the Tire Pressure

**Service Interval:** Every 50 hours

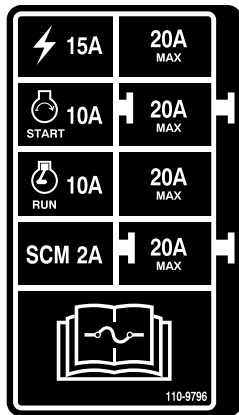
Check the pressure after every 50 operating hours or monthly, whichever occurs first (Figure 53).

Maintain the air pressure in the front and rear tires. The correct air pressure is 15 psi (103 kPa) in the rear tires and 25 psi (172 kPa) in the caster wheels. Uneven tire pressure can cause uneven cut. Check the tires when they are cold to get the most accurate pressure reading.

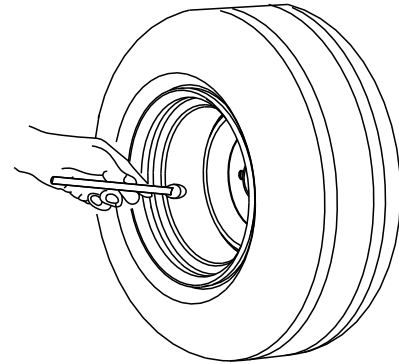


**Figure 51**

1. Side panel cover      2. Latches



**Figure 52**



**Figure 53**

## Replacing the Caster Wheels and Bearings

1. Obtain a new caster wheel assembly, cone bearings, and bearing seals for your Authorized Toro Distributor.
2. Remove the locknut from the bolt holding the caster wheel assembly between the castor fork (Figure 54).

# Cooling System Maintenance

## ⚠ DANGER

Discharge of hot pressurized coolant or touching hot radiator and surrounding parts can cause severe burns.

- Do not remove the radiator cap when the engine is hot. Always allow the engine to cool at least 15 minutes or until the radiator cap is cool enough to touch without burning your hand before removing the radiator cap.
- Do not touch radiator and surrounding parts that are hot.

## ⚠ DANGER

The rotating fan and drive belt can cause personal injury.

- Do not operate the machine without the covers in place.
- Keep fingers, hands and clothing clear of rotating fan and drive belt.
- Shut off the engine and remove the ignition key before performing maintenance.

## ⚠ CAUTION

Swallowing engine coolant can cause poisoning.

- Do not swallow engine coolant.
- Keep out of reach from children and pets.

## Checking the Cooling System

**Service Interval:** Before each use or daily

The cooling system is filled with a 50/50 solution of water and permanent ethylene glycol anti freeze. Check the level of the coolant in the expansion tank at the beginning of each day before starting the engine. The capacity of the cooling system is 6 quarts (7.5 l).

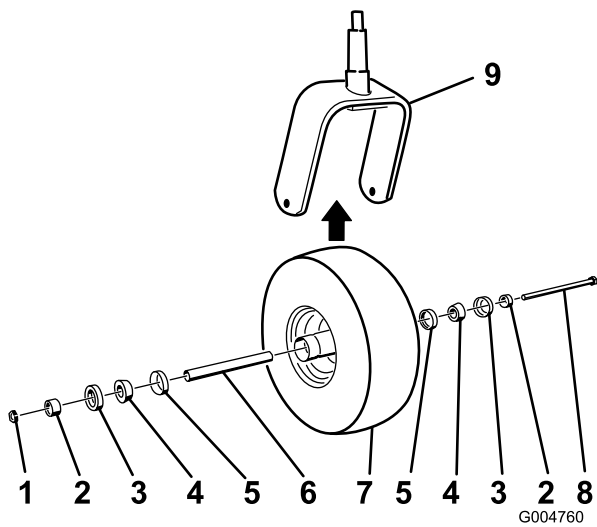


Figure 54

- |                       |                 |
|-----------------------|-----------------|
| 1. Nut                | 6. Spacer       |
| 2. Bearing spacer     | 7. Caster wheel |
| 3. Outer bearing seal | 8. Axle bolt    |
| 4. Cone bearing       | 9. Caster fork  |
| 5. Inner bearing seal |                 |

3. Grasp the castor wheel and slide the bolt out of the fork or pivot arm.
4. Discard the old castor wheel and bearings.
5. Assemble the castor wheel by pushing the cone bearings and seals, packed with grease, into the wheel hub, positioned as shown in Figure 54.
6. Slide the spacer into the wheel hub through the bearings, captivating the spacer inside the wheel hub with 2 bearing spacers.

**Important:** Ensure that the seal lips are not folded in.

7. Install the castor wheel assembly between the castor fork and secure it in place with the bolt and locknut.
8. Tighten the nut until the wheel no longer spins freely, then back it off just until the wheel spins freely.
9. Attach a grease gun to the grease fitting on the castor wheel and fill it with No. 2 General Purpose Lithium Base Grease.

1. Check the level of the coolant in the expansion tank (Figure 55). The coolant level should be between the marks on the side of the tank.

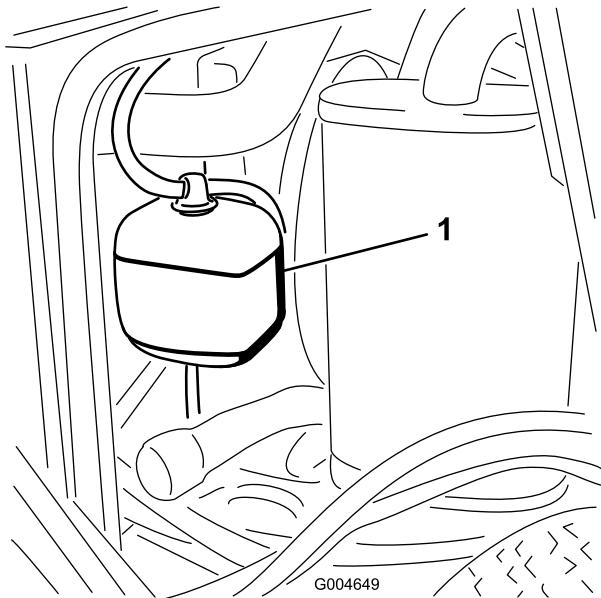


Figure 55

3. After the radiator is thoroughly cleaned, clean out debris that may have collected in the channel at the radiator base.
4. Close the hood.

1. Expansion tank

- 
2. If coolant level is low, remove the expansion tank cap and replenish the system. **Do not overfill.**
  3. Install the expansion tank cap.

## Cleaning the Radiator

**Service Interval:** Before each use or daily

Every 1,500 hours

Every 200 hours

Every 2 years

To prevent the engine from overheating, the radiator must be kept clean. Normally, check the radiator daily and, if necessary, clean any debris off these parts. However, it will be necessary to check and clean the radiator frequently in extremely dusty and dirty conditions.

**Note:** If the mower deck or engine shuts off due to overheating, first check the radiator for excessive buildup of debris.

Clean the radiator as follows:

1. Open the hood.
2. Working from the fan side of the radiator, blow out debris with low pressure (50 psi) compressed air (**do not use water**). Repeat the step from the front of the radiator and again from the fan side.

# Brake Maintenance

## Adjusting the Parking Brake Interlock Switch

1. Stop the machine, move the control levers fully into the neutral-locked position, set the parking brake, and remove the ignition key.
2. Remove the bolts securing the front panel and remove the panel (Figure 56).

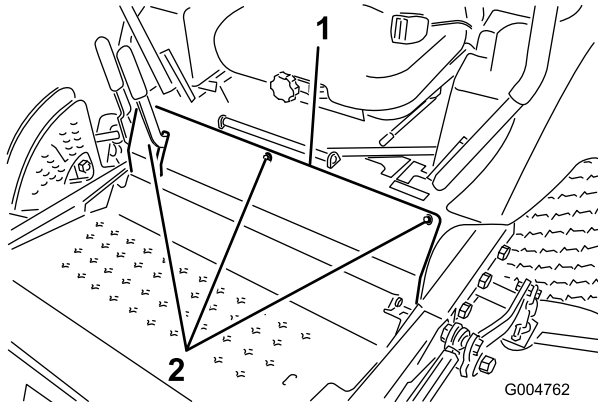


Figure 56

1. Front panel bolts

3. Loosen the two jam nuts securing the parking brake interlock switch to the mounting bracket.

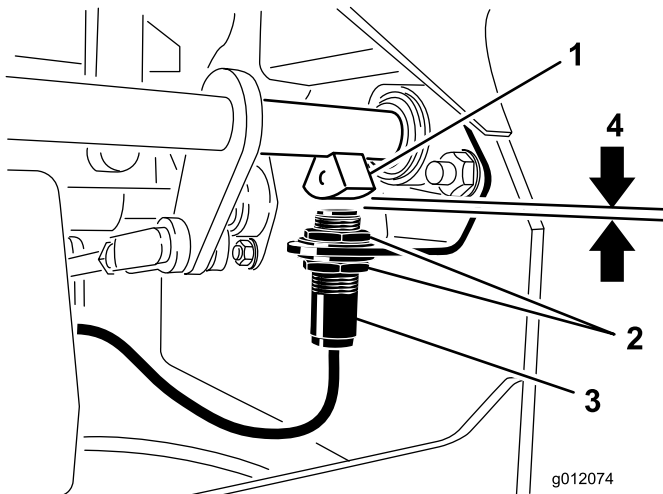


Figure 57

- |                       |                                   |
|-----------------------|-----------------------------------|
| 1. Brake shaft sensor | 3. Parking brake interlock switch |
| 2. Jam nuts           | 4. 5/32 inch (3.9 mm)             |

4. Move the switch up or down on the bracket until the distance between the brake shaft sensor and the switch plunger is 5/32 inch (3.9 mm) (Figure 57).

**Note:** Make sure the brake shaft sensor does not contact the switch plunger.

5. Secure the switch jam nuts.
6. Test the adjustment as follows:
  - A. Ensure that the parking brake is engaged and you are not sitting on the seat, then start the engine.
  - B. Move the control levers out of the neutral locked position.  
The engine should stop. If not, recheck the adjustment you made to the switch.
7. Install the front panel.

# Belt Maintenance

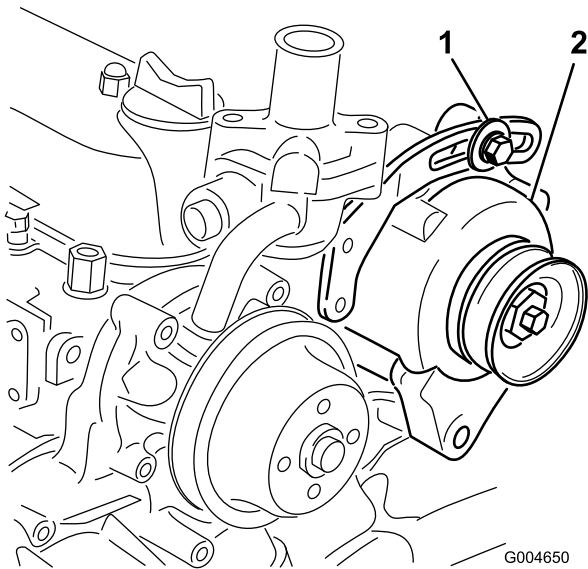
## Checking the Alternator Belt

**Service Interval:** Every 200 hours

After the first 10 hours

Check tension of alternator belt (Figure 58) after every 200 operating hours.

1. Apply 10 lb of force to the alternator belt, midway between the pulleys.
2. If the deflection is not 3/8 in. (10 mm), loosen the alternator mounting bolts.



**Figure 58**

1. Mounting bolt
2. Alternator

3. Increase or decrease the alternator belt tension and tighten the bolts.
4. Check the deflection of the belt again to ensure that the tension is correct.

## Replacing the Blade Drive Belts

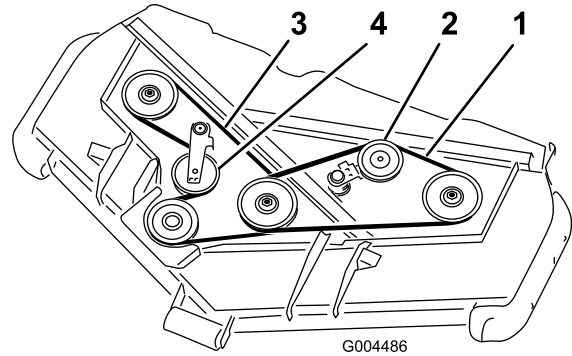
**Service Interval:** Every 50 hours

The blade drive belts, tensioned by the spring loaded idler pulleys, are very durable. However, after many hours of use, the belts will show signs of wear. Signs of a worn belt are: squealing when belt is rotating, blades slipping when cutting grass, frayed edges, burn marks and cracks. Replace the belts if any of these conditions are evident.

1. Lower the cutting unit to the 1 inch height of cut setting, move the throttle lever to the Slow position,

stop the engine, set the parking brake, and remove the ignition key.

2. Remove the belt covers from the top of the cutting unit and set the covers aside.
3. Using a breaker bar or similar tool, move the idler pulley for the top belt (Figure 59) away from the top drive belt to release the belt tension and allow the belt to be slipped off the pulleys.



**Figure 59**

1. Top belt
2. Top idler pulley
3. Bottom belt
4. Bottom idler pulley

4. Using a breaker bar or similar tool, move the idler pulley for the bottom belt (Figure 59) away from the bottom drive belt to release the belt tension and allow the belt to be slipped off the pulleys.
5. Route a new belt around the gearbox pulley, bottom spindle pulleys, and idler pulley assembly as shown in Figure 59.
6. Route a new belt around the top spindle pulleys and idler pulley assembly as shown in Figure 59.
7. Install the belt covers.

# Controls System Maintenance

## Adjusting the Control Lever Neutral Interlock Switch

1. Stop the machine, move the control levers fully into the neutral-locked position, set the parking brake, and remove the ignition key.
2. Remove the bolts securing the front panel and remove the panel (Figure 60).

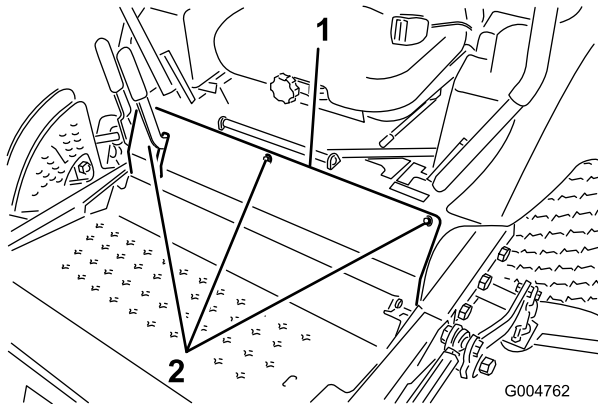


Figure 60

1. Front panel bolts

3. Loosen the 2 screws securing the interlock switch (Figure 61).

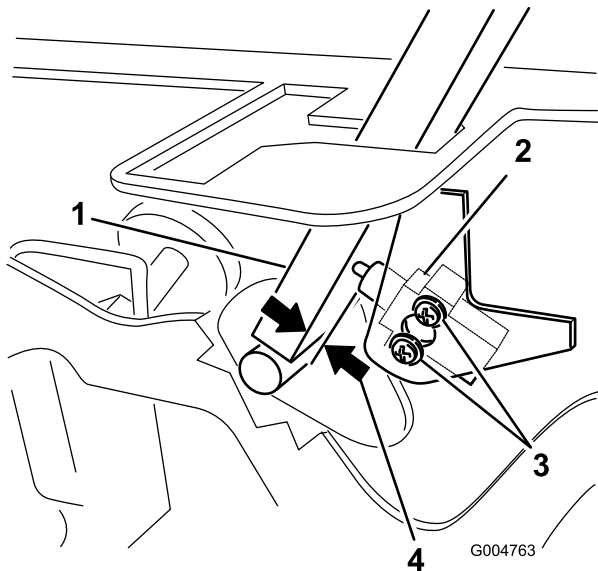


Figure 61

- |                             |                                      |
|-----------------------------|--------------------------------------|
| 1. Control lever            | 3. Screws                            |
| 2. Neutral interlock switch | 4. 0.015 to 0.045 inch (0.4 to 1 mm) |

4. Holding the control lever against the frame, move the switch toward the lever until the distance between lever and switch body is 0.015 to 0.045 inch (0.4 to 1 mm) (Figure 61).
5. Secure the switch.
6. Repeat steps 3 to 5 for the other lever.
7. Install the front panel.

## Adjusting the Control Lever Neutral Return

If the motion control levers do not align with the neutral slots when released from the reverse drive position, adjustment is required. Adjust each lever, spring, and rod separately.

1. Disengage the PTO, move the motion control levers to the neutral locked position and set the parking brake.
2. Move the throttle lever to the Slow position, stop the engine, remove the key, and wait for all moving parts to stop before leaving the operating position.
3. Remove the bolts securing the front panel and remove the panel (Figure 62).

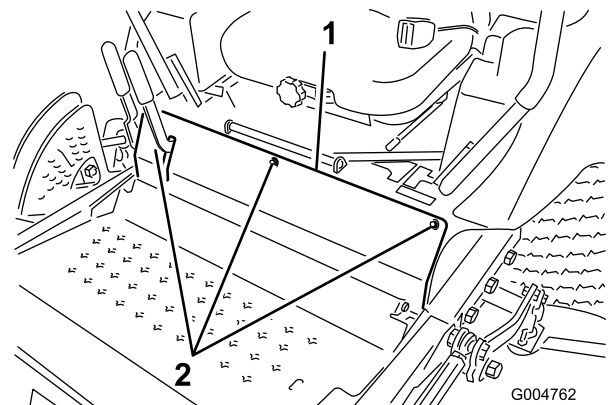


Figure 62

1. Front panel bolts

4. Move one of the levers to the neutral position but **not locked** (Figure 64).
5. Pull the lever back until the clevis pin (on an arm above the pivot shaft) contacts the end of the slot (just beginning to put pressure on the spring) (Figure 63).

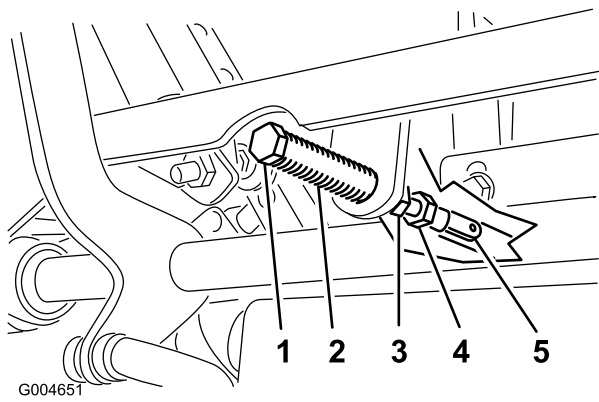


Figure 63

- |               |                    |
|---------------|--------------------|
| 1. Clevis pin | 4. Adjustment bolt |
| 2. Slot       | 5. Yoke            |
| 3. Jam nuts   |                    |

6. Check where the control lever is relative to notch in console (Figure 64). It should be centered allowing lever to pivot outward to the neutral lock position.

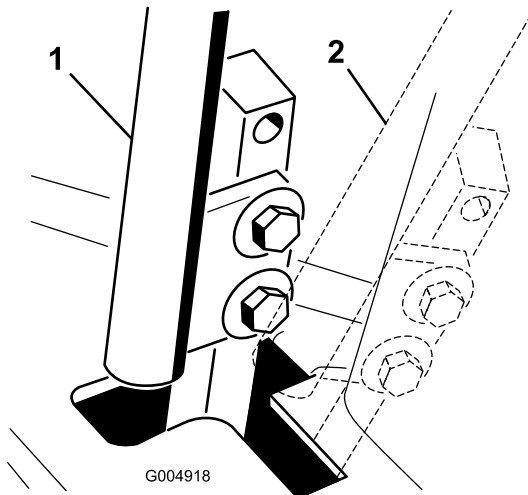


Figure 64

- |                     |                            |
|---------------------|----------------------------|
| 1. Neutral position | 2. Neutral locked position |
|---------------------|----------------------------|

7. If adjustment is needed, loosen the nut and jam nut against the yoke (Figure 63).
8. Applying slight rearward pressure on the motion control lever, turn the head of the adjustment bolt in the appropriate direction until the control lever is centered in the neutral lock position (Figure 63).

**Note:** Keeping rearward pressure on the lever will keep the pin at the end of the slot and allow the adjustment bolt to move the lever to the appropriate position.

9. Tighten the nut and jam nut (Figure 63).
10. Repeat steps 4 through 9 for the other control lever.
11. Install the front panel.

## Adjusting the Traction Drive for Neutral

This adjustment must be made with drive wheels turning.

### ⚠ DANGER

Mechanical or hydraulic jacks may fail to support machine and cause a serious injury.

- Use jack stands when supporting machine.
- Do not use hydraulic jacks.

### ⚠ WARNING

The engine must be running to perform this adjustment. Contact with moving parts or hot surfaces may cause personal injury.

Keep hands, feet, face, clothing, and other body parts away from rotating parts, muffler, and other hot surfaces.

1. Raise the frame onto stable jack stands so that the drive wheels can rotate freely.
2. Slide seat forward, unlatch it, and swing it up and forward.
3. Disconnect the electrical connector from the seat safety switch. Temporarily install a jumper wire across terminals in the wiring harness connector.
4. Start the engine, ensure that the throttle lever is midway between the Fast and Slow positions, and release the parking brake

**Note:** The motion control levers must be in the neutral locked position while making any adjustments.

5. Adjust the pump rod length on one side by rotating the hex shaft, in the appropriate direction, until the corresponding wheel is still or slightly creeping in reverse (Figure 65).

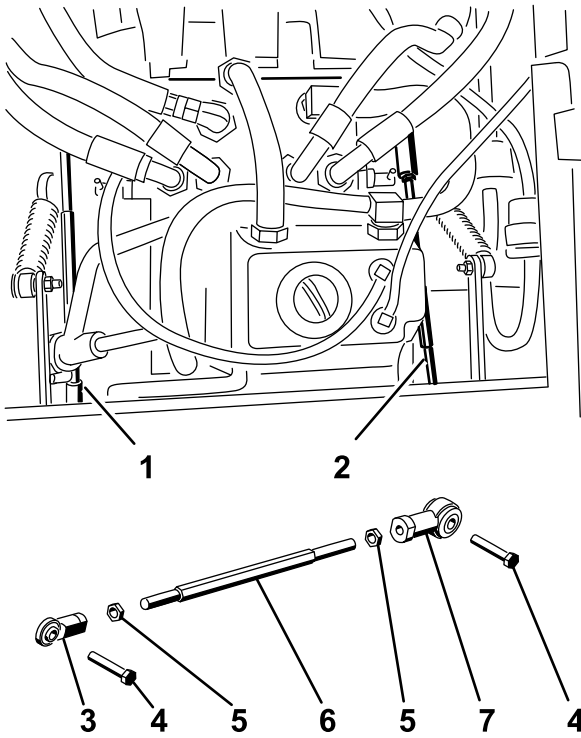


Figure 56

Figure 65

- |                   |               |
|-------------------|---------------|
| 1. Right pump rod | 5. Jam Nut    |
| 2. Left pump rod  | 6. Hex shaft  |
| 3. Ball joint     | 7. Ball joint |
| 4. Bolt           |               |

6. Move the motion control lever forward and reverse, then back to neutral. The wheel must stop turning or slightly creep in reverse.
7. Move the throttle lever to the Fast position. Make sure wheel remains stopped or slightly creeps in reverse, adjust if necessary.
8. Repeat steps 5 through 7 for the other side.
9. Tighten the jam nuts at the ball joints (Figure 63).
10. Move the throttle lever to the Slow position and stop the engine.
11. Remove the jumper wire from the wire harness connector and plug the connector into the seat switch.

### **⚠ WARNING**

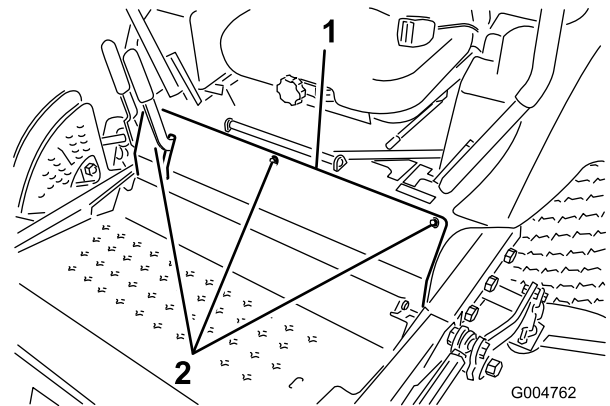
Electrical system will not perform proper safety shut off with jumper wire installed.

- Remove jumper wire from wire harness connector and plug connector into seat switch when adjustment is completed.
- Never operate this unit with jumper installed and seat switch bypassed.

12. Lower the seat into position.
13. Remove the jack stands.

## Adjusting the Maximum Ground Speed

1. Disengage the PTO, move the motion control levers to the neutral locked position and set the parking brake.
2. Move the throttle lever to the Slow position, stop the engine, remove the key, and wait for all moving parts to stop before leaving the operating position.
3. Remove the bolts securing the front panel and remove the panel (Figure 66).

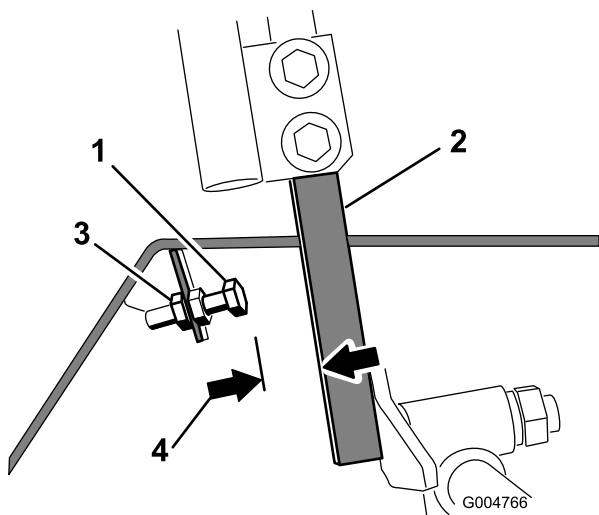


G004762

Figure 66

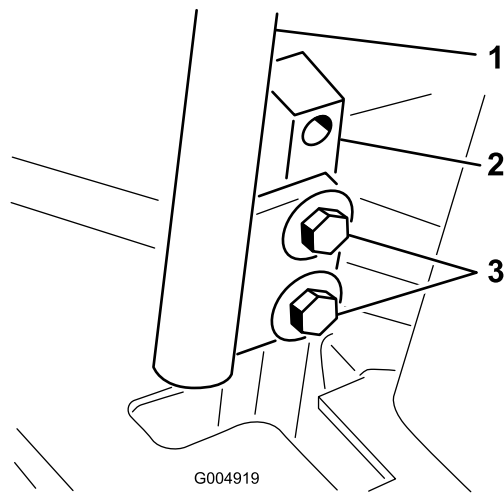
1. Front panel bolts
- 
4. Loosen the jam nut on the stop bolt for one of the control levers (Figure 67).





**Figure 67**

- |                  |                        |
|------------------|------------------------|
| 1. Stop bolt     | 3. Jam nut             |
| 2. Control lever | 4. 0.060 inch (1.5 mm) |



**Figure 68**

- |                       |          |
|-----------------------|----------|
| 1. Control lever      | 3. Bolts |
| 2. Control lever post |          |

5. Thread the stop bolt all the way in (away from the control lever).
6. Push the control lever all the way forward until it stops and hold it there.
7. Thread the stop bolt out (towards the control lever) until there is a gap of 0.060 inch (1.5 mm) between the head of the stop bolt and the control lever.
8. Tighten the jam nut to secure the stop bolt in place.
9. Repeat steps 4 through 8 for the other control lever.
10. Install the front panel.

**Note:** If you wish to reduce the maximum machine speed, set the speed for both control levers as directed above, then back each stop bolt out an equal amount toward the control lever until you reach the maximum speed you desire (you will likely have to test your adjustment several times). Ensure that the machine drives straight and does not turn when both control levers are pushed all the way forward. If the machine turns, you do not have the stop bolts evenly set and will need to adjust them further.

## Adjusting the Tracking

1. Disengage the PTO, move the motion control levers to the neutral locked position and set the parking brake.
2. Move the throttle lever to the Slow position, stop the engine, remove the key, and wait for all moving parts to stop before leaving the operating position.
3. Loosen the bolts securing the control levers (Figure 68)

4. Have someone push the control lever posts (not the control levers) all the way forward into the maximum speed position and hold them there.
5. Adjust the control levers so that they line up (Figure 69) and tighten the bolts, securing the levers to the posts.

# Hydraulic System Maintenance

The reservoir is filled at the factory with approximately 5 quarts (4.7 l) of high quality tractor transmission/hydraulic fluid. The recommended replacement fluid is as follows:

**Toro Premium Transmission/Hydraulic Tractor Fluid**  
(Available in 5 gallon pails or 55 gallon drums. See parts catalog or Toro distributor for part numbers.)

Alternate fluids: If the Toro fluid is not available, Mobil® 424 hydraulic fluid may be used.

**Note:** Toro will not assume responsibility for damage caused by improper substitutions.

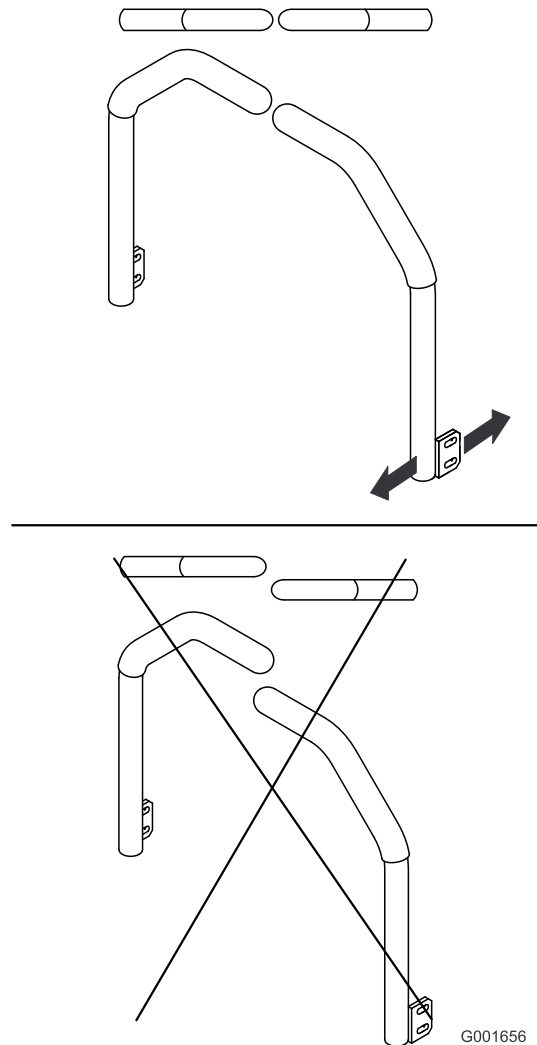
**Note:** Many hydraulic fluids are almost colorless, making it difficult to spot leaks. A red dye additive for the hydraulic system oil is available in 2/3 oz. (20 ml) bottles. One bottle is sufficient for 4-6 gal (15-22 l) of hydraulic oil. Order part number 44-2500 from your authorized Toro distributor.

## Checking the Hydraulic System

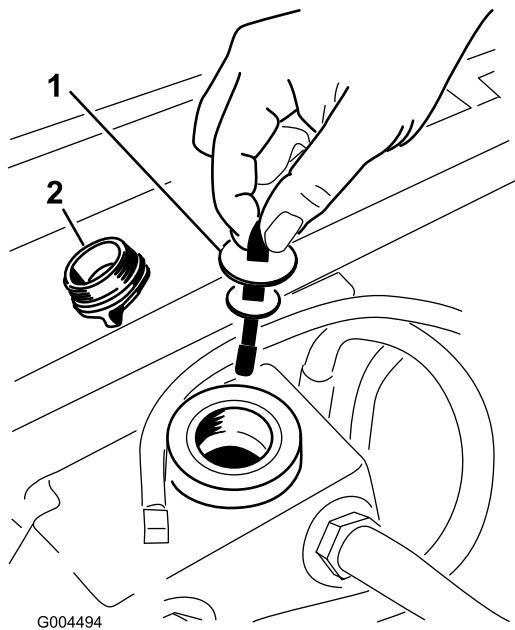
**Service Interval:** Before each use or daily

Check the level of the hydraulic fluid before the engine is first started and daily thereafter.

1. Position the machine on a level surface. Place the controls in the neutral locked position and start the engine. Run engine at lowest possible RPM to purge the system of air. **Do not engage the PTO.** Raise the deck to extend lift cylinders, stop the engine, and remove the key.
2. Raise the seat to access the hydraulic fluid tank.
3. Remove the hydraulic fill cap (Figure 70) from filler neck.

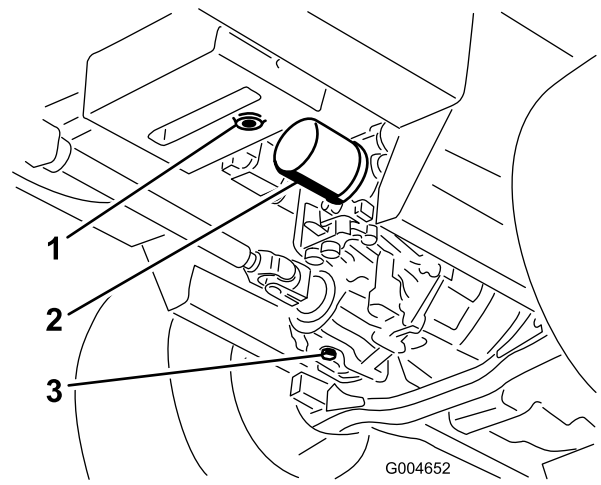


**Figure 69**



**Figure 70**

1. Dipstick
2. Fill cap



**Figure 71**

1. Hydraulic reservoir drain plug
2. Filter
3. Transmission case drain plug

4. Remove the dipstick and wipe it with a clean rag (Figure 70).
5. Place the dipstick into the filler neck; then remove it and check level of fluid (Figure 70).

If level is not within notched area of the dipstick, add enough high quality hydraulic fluid to raise level to within the notched area. **Do not overfill.**

6. Replace the dipstick and thread the fill cap finger-tight onto filler neck.
7. Check all hoses and fittings for leaks.

4. Clean the area around the hydraulic oil filter and remove it (Figure 71).
5. Immediately install a new hydraulic oil filter.
6. Install the hydraulic reservoir and transmission case drain plugs.
7. Fill the reservoir to the proper level (approximately 6 quarts); refer to Checking the Hydraulic Fluid.
8. Start the engine and check for oil leaks. Allow the engine to run for about five minutes, then shut it off.
9. After two minutes, check the level of the hydraulic fluid; refer to Checking the Hydraulic Fluid.

## Changing the Hydraulic Oil And Filter

**Service Interval:** After the first 200 hours  
Every 800 hours

Initially, replace the hydraulic oil filter after the first 200 hours of operation.

Replace the filter and oil after every 800 hours of operation.

1. Disengage the PTO, move the motion control levers to the neutral locked position and set the parking brake.
2. Move the throttle lever to the Slow position, stop the engine, remove the key, and wait for all moving parts to stop before leaving the operating position.
3. Place a large pan under the hydraulic reservoir and transmission case and remove the plugs, draining all of the hydraulic fluid (Figure 71).

# Mower Deck Maintenance

## ⚠ WARNING

If you raise the machine using only a jack to support it while you work under the mower deck, the jack could tip, causing the mower deck to fall, crushing you or bystanders.

Always secure the machine with at least 2 jack stands when you have the mower deck raised.

## ⚠ CAUTION

On the top of the mower deck are two links that connect them to the frame. Connected to these links are torsion springs that are under tension (Figure 72). If you disconnect the link the stored energy in the torsion spring will be released and could cause the links to move, damaging your hands or fingers.

Be careful when removing the mower deck from the frame and secure the links before disconnecting them from the frame.

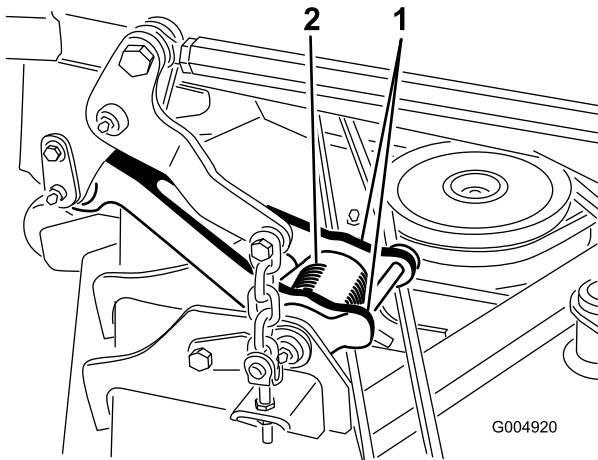


Figure 72

1. Link

2. Torsion spring

## Servicing the Cutting Blades

Maintain sharp blades throughout the cutting season because sharp blades cut cleanly without tearing or shredding the grass blades. Tearing and shredding turns grass brown at the edges, which slows growth and increases the chance of disease.

Check the blades daily for sharpness, and for any wear or damage. Sharpen the blades as necessary. If a blade is

damaged or worn, replace it immediately with a genuine Toro replacement blade.

## ⚠ DANGER

A worn or damaged blade can break, and a piece of the blade could be thrown into the operator's or bystander's area, resulting in serious personal injury or death.

- Inspect the blade periodically for wear or damage.
- Replace a worn or damaged blade.

Inspect and check the blades every 8 hours.

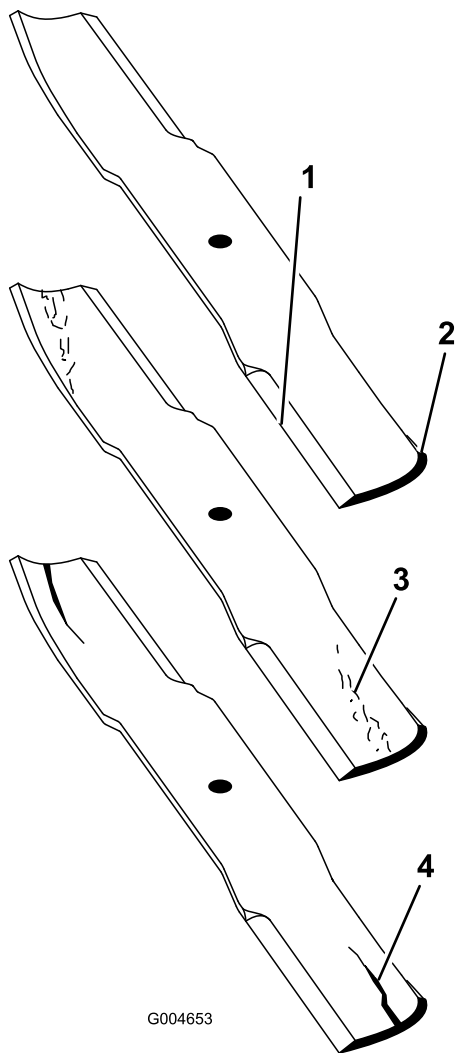
## Before Inspecting or Servicing the Blades

1. Disengage the PTO, move the motion control levers to the neutral locked position and set the parking brake.
2. Move the throttle lever to the Slow position, stop the engine, remove the key, and wait for all moving parts to stop before leaving the operating position.

## Inspecting the Blades

**Service Interval:** Before each use or daily

1. Inspect the cutting edges (Figure 73). If the edges are not sharp or have nicks, remove and sharpen the blades. Refer to Sharpening the Blades.
2. Inspect the blades, especially the curved area (Figure 73). If you notice any damage, wear, or a slot forming in this area (Figure 73), immediately install a new blade.



G004653

**Figure 73**

- |                 |                      |
|-----------------|----------------------|
| 1. Cutting Edge | 3. Wear/slot Forming |
| 2. Curved Area  | 4. Crack             |

**⚠ DANGER**

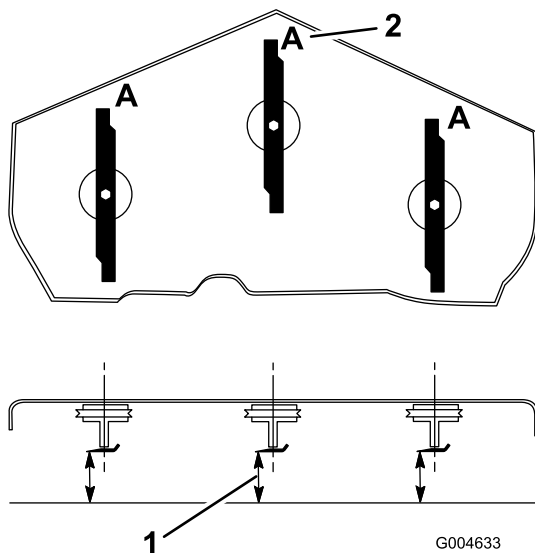
If you allow the blade to wear, a slot will form between the sail and flat part of the blade. Eventually a piece of the blade may break off and be thrown from under the housing, possibly resulting in serious injury to you or bystanders.

- Inspect the blade periodically for wear or damage.
- Never try to straighten a blade that is bent or weld a broken or cracked blade.
- Replace a worn or damaged blade.

**Checking for Bent Blades**

1. Disengage the PTO, move the motion control levers to the neutral locked position and set the parking brake.

2. Move the throttle lever to the Slow position, stop the engine, remove the key, and wait for all moving parts to stop before leaving the operating position.
3. Rotate the blades until the ends face forward and backward (Figure 74). Measure from a level surface to the cutting edge, position A, of the blades (Figure 74). Note this dimension.



G004633

**Figure 74**

1. Measure here from blade to hard surface
2. Position A

4. Rotate the opposite ends of the blades forward.
5. Measure from a level surface to the cutting edge of the blades at the same position as in step 3 above. The difference between the dimensions obtained in steps 3 and 4 must not exceed 1/8 inch (3 mm). If this dimension exceeds 1/8 inch (3 mm), the blade is bent and must be replaced; refer to Removing the Blades and Installing the Blades.

**⚠ WARNING**

A blade that is bent or damaged could break apart and could seriously injure or kill you or bystanders.

- Always replace bent or damaged blade with a new blade.
- Never file or create sharp notches in the edges or surfaces of blade.

**Removing the Blades**

Blades must be replaced if a solid object is hit, if the blade is out of balance or is bent. To ensure optimum performance and continued safety conformance of the machine, use genuine Toro replacement blades. Replacement blades made by other manufacturers may result in non-conformance with safety standards.

## ⚠ WARNING

Contact with a sharp blade can cause serious injury.

Wear gloves or wrap sharp edges of the blade with a rag.

1. Hold the blade end using a rag or thickly-padded glove.
2. Remove the blade bolt, anti-scalp plate, and blade from the spindle shaft (Figure 77).

## Sharpening the Blades

### ⚠ WARNING

When sharpening blade, pieces of blade could be thrown and cause serious injury.

Wear proper eye protection when sharpening blades.

1. Sharpen the cutting edge at both ends of the blade (Figure 75). Maintain the original angle. The blade retains its balance if the same amount of material is removed from both cutting edges.

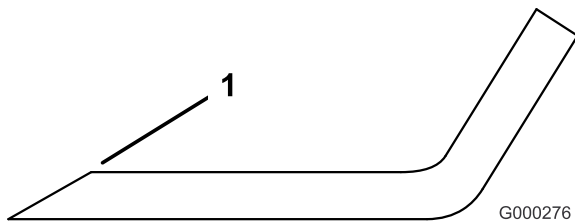


Figure 75

1. Sharpen at original angle

2. Check the balance of the blade by putting it on a blade balancer (Figure 76). If the blade stays in a horizontal position, the blade is balanced and can be used. If the blade is not balanced, file some metal off the end of the sail area only (Figure 77). Repeat this procedure until the blade is balanced.

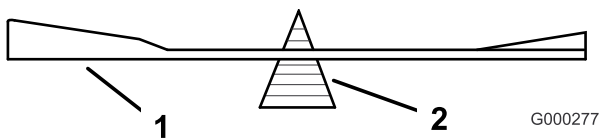


Figure 76

1. Blade
2. Balancer

## Installing the Blades

1. Install the blade onto the spindle shaft (Figure 77).

**Important:** The curved part of the blade must be pointing upward toward the inside of the mower to ensure proper cutting.

2. Install the anti-scalp plate and blade bolt (Figure 77).

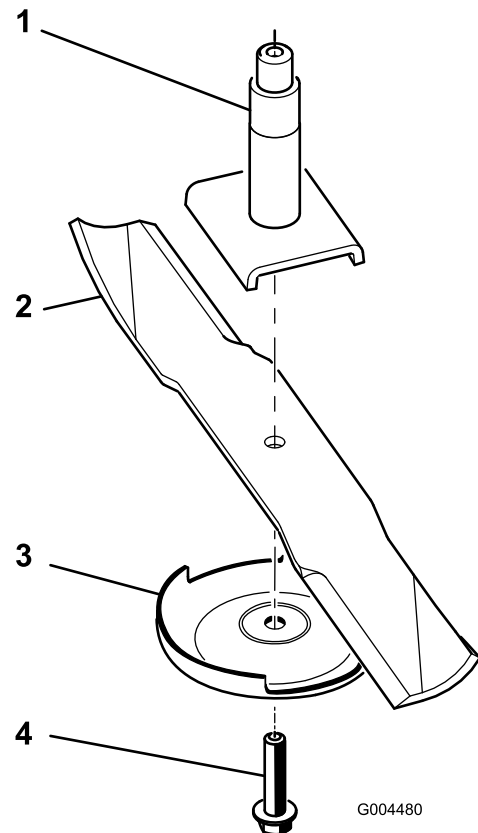


Figure 77

1. Spindle
2. Sail Area of Blade
3. Anti-scalp plate
4. Blade Bolt

3. Torque the blade bolt to 85-110 ft-lb (115-150 N·m).

## Correcting Mower Deck Mismatch

If the cut is uneven across the mower swath, correct it as follows:

1. Position the machine on a level surface on the shop floor.
2. Set the cutting unit to the desired height of cut, move the throttle lever to the Slow position, stop the engine, set the parking brake, and remove the ignition key.
3. Check and adjust front and rear tractor tire pressure; refer to Checking Tire Pressure.
4. Check for bent blades.
5. Remove the covers from the top of the cutting units.
6. Rotate the blade on each spindle until the ends face forward and backward.

- Measure from the floor to the front tip of the cutting edge.
- Adjust the jam nuts securing the deck yokes/chains to the mower deck until the mower deck is level.

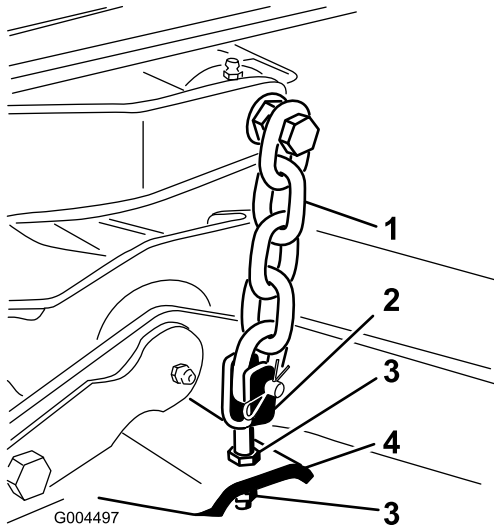


Figure 78

- |          |               |
|----------|---------------|
| 1. Chain | 3. Jam nut    |
| 2. Yoke  | 4. Mower deck |

## Adjusting the Mower Deck Pitch

Cutting unit pitch is the difference in height-of-cut from the front of the blade plane to the back of the blade plane. Toro recommends a blade pitch of approximately 5/16 inch (8 mm). That is the back of the blade plane is 5/16 inch (8 mm) higher than the front.

- Position the machine on a level surface on the shop floor.
- Set the cutting unit to the desired height-of-cut, move the throttle lever to the Slow position, stop the engine, set the parking brake, and remove the ignition key.
- Rotate the center blade so that it points straight forward.
- Using a short ruler, measure from the floor to the front tip of the blade.
- Rotate the same blade tip to the rear and measure from the floor to the tip of the blade at the rear of the deck.
- Subtract the front dimension from the rear dimension to calculate the blade pitch.
- Adjust the jam nuts securing the rear deck yokes/chains to raise the rear of the deck so that the blade pitch is set to 5/16 inch (8 mm) (Figure 79).

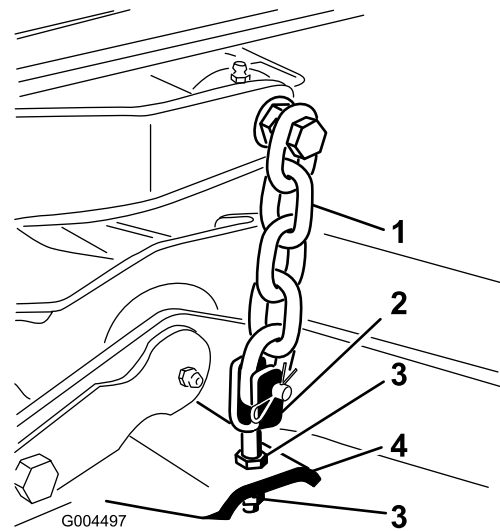


Figure 79

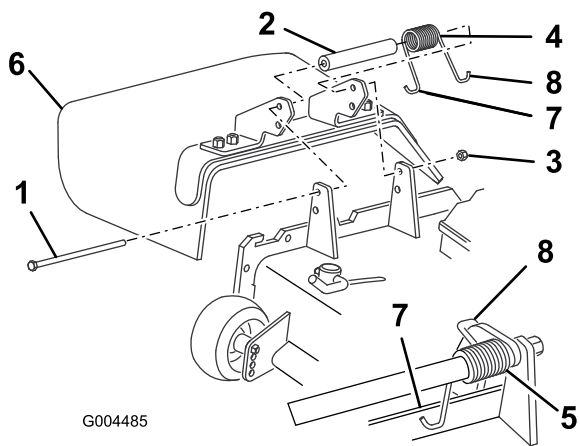
- |          |               |
|----------|---------------|
| 1. Chain | 3. Jam nut    |
| 2. Yoke  | 4. Mower deck |

## Replacing the Grass Deflector

### ⚠ WARNING

An uncovered discharge opening could allow the lawn mower to throw objects in the operator's or bystander's direction and result in serious injury. Also, contact with the blade could occur.

- Never operate the lawn mower without a mulch kit or grass deflector installed.
  - Make sure the grass deflector is in the down position.
- Lower the cutting unit to the shop floor, move the throttle lever to the Slow position, stop the engine, set the parking brake, and remove the ignition key.
  - Remove the locknut, bolt, spring and spacer holding the deflector to the pivot brackets (Figure 80). Remove damaged or worn grass deflector.



**Figure 80**

- |            |  |
|------------|--|
| 1. Bolt    | 5. Spring installed  |
| 2. Spacer  | 6. Grass Deflector   |
| 3. Locknut | 7. Left hand hook end of spring, place behind deck edge before installing bolt |
| 4. Spring  | 8. Right hand hook end of spring   |

- Place the spacer and spring between the replacement grass deflector brackets (Figure 80). Place the left hand J hook end of the spring behind the deck edge.

**Note:** Make sure the left hand J hook end of the spring is installed behind the deck edge before installing the bolt as shown in Figure 80.

- Install the bolt and nut. Place the right hand J hook end of the spring around the grass deflector (Figure 80).

**Important:** The grass deflector must be able to lower down into position. Lift the deflector up to test that it lowers into the full down position.

## Cleaning

### Cleaning Under the Mower

**Service Interval:** Before each use or daily

Remove the grass buildup under the mower daily.

- Disengage the PTO, move the motion control levers to the neutral locked position and set the parking brake.
- Move the throttle lever to the Slow position, stop the engine, remove the key, and wait for all moving parts to stop before leaving the operating position.
- Raise the mower to the transport position.
- Raise the front of the machine by using jack stands.
- Thoroughly clean the underside of the mower with water.

### Waste Disposal

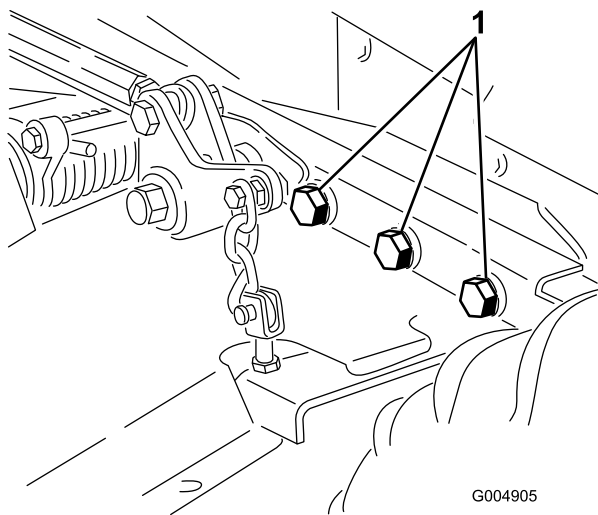
Engine oil, batteries, hydraulic oil, and engine coolant are pollutants to the environment. Dispose of these according to your state and local regulations.



# Storage

## Machine

1. Thoroughly clean the machine, deck and the engine, paying special attention to these areas:
  - Radiator and radiator screen
  - Underneath the deck
  - Under the deck belt covers
  - Counterbalance springs
  - PTO shaft assembly
  - All grease fittings and pivot points
  - Remove the control panel and clean out inside of the control box
  - Beneath the seat plate and top of the transmission
2. Check and adjust front and rear tractor tire pressure; refer to Checking Tire Pressure.
3. Remove, sharpen, and balance the mower blades. Install the blades and torque the blade fasteners to 85-110 ft-lb (115-149 N·m).
4. Check all fasteners for looseness and tighten them as necessary. Especially torque the 6 bolts securing the mower deck frame to the traction unit (Figure 81) to 265 ft-lb (359 N·m).



**Figure 81**  
Right side not shown.

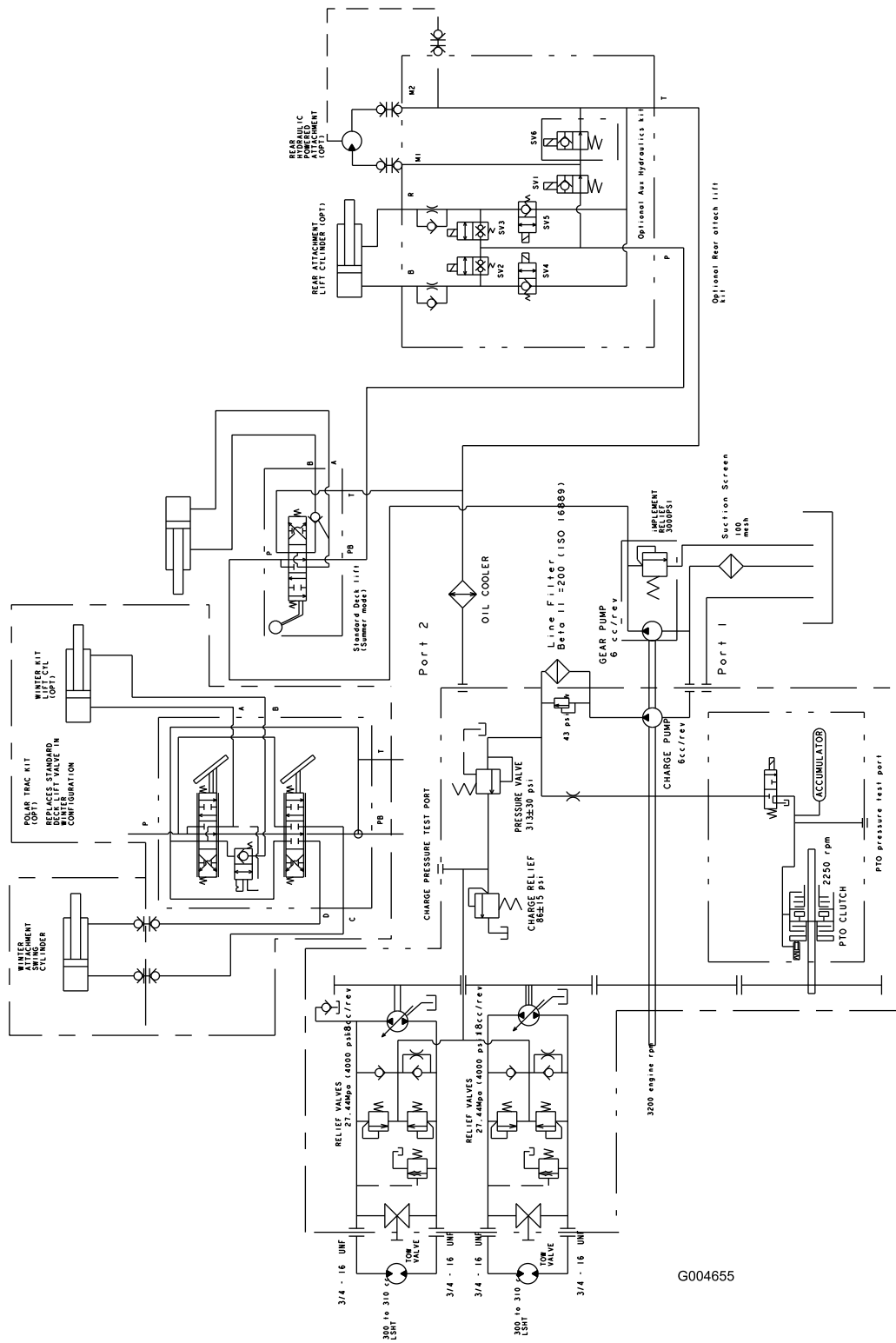
1. Bolts
- 
5. Grease or oil all grease fittings, pivot points, and transmission by-pass valve pins. Wipe off any excess lubricant.
  6. Lightly sand and use touch up paint on painted areas that are scratched, chipped or rusted. Repair any dents in the metal body.
  7. Service the battery and cables as follows:

- A. Remove the battery terminals from the battery posts.
- B. Clean the battery, terminals, and posts with a wire brush and baking soda solution.
- C. Coat the cable terminals and battery posts with Grafo 112X skin-over grease (Toro Part No. 505-47) or petroleum jelly to prevent corrosion.
- D. Slowly recharge the battery for 24 hours every 60 days to prevent lead sulfation of the battery.

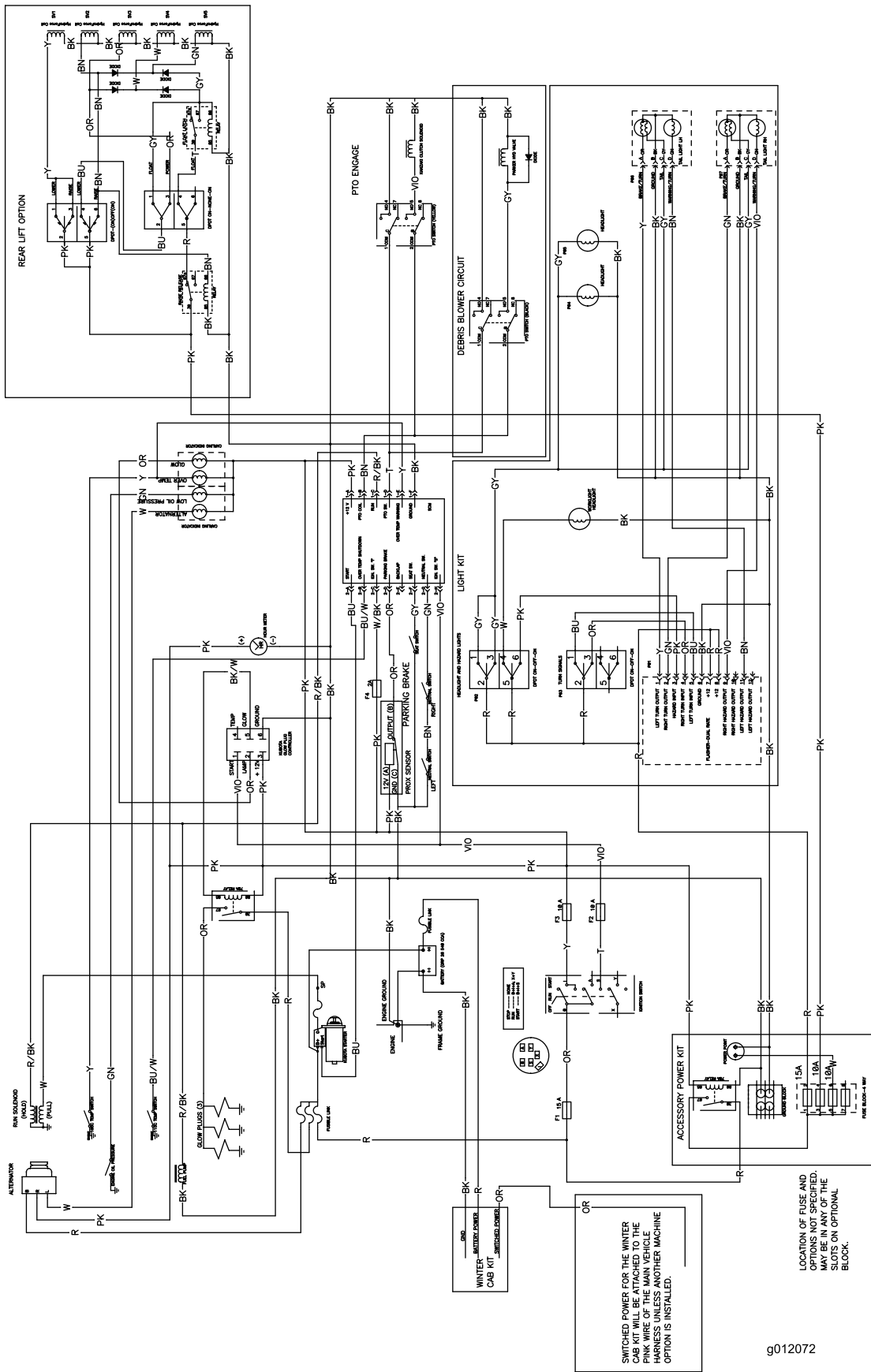
## Engine

1. Drain the engine oil from the oil pan and replace the drain plug.
2. Remove and discard the oil filter. Install a new filter.
3. Refill the engine with 4 quarts (3.8 l) of recommended motor oil. Refer to Changing the Engine Oil.
4. Start the engine and run it at idle speed for two minutes.
5. Drain the fuel from the fuel tank, fuel lines, pump, filter, and separator. Flush the fuel tank with clean diesel fuel and connect all fuel lines.
6. Thoroughly clean and service the air cleaner assembly.
7. Seal the air cleaner inlet and the exhaust outlet with weather proof masking tape.
8. Check the oil filler cap and fuel tank cap to ensure they are securely in place.

# Schematics



Hydraulic Schematic (Rev. A)



Electrical Schematic (Rev. A)

g012072



# The Toro Total Coverage Guarantee

## A Limited Warranty

### Conditions and Products Covered

The Toro® Company and its affiliate, Toro Warranty Company, pursuant to an agreement between them, jointly warrant your Toro Commercial product ("Product") to be free from defects in materials or workmanship for two years or 1500 operational hours\*, whichever occurs first. This warranty is applicable to all products with the exception of Aerators (refer to separate warranty statements for these products). Where a warrantable condition exists, we will repair the Product at no cost to you including diagnostics, labor, parts, and transportation. This warranty begins on the date the Product is delivered to the original retail purchaser.

\* Product equipped with an hour meter.

### Instructions for Obtaining Warranty Service

You are responsible for notifying the Commercial Products Distributor or Authorized Commercial Products Dealer from whom you purchased the Product as soon as you believe a warrantable condition exists. If you need help locating a Commercial Products Distributor or Authorized Dealer, or if you have questions regarding your warranty rights or responsibilities, you may contact us at:

Commercial Products Service Department  
Toro Warranty Company  
8111 Lyndale Avenue South  
Bloomington, MN 55420-1196  
E-mail: commercial.warranty@toro.com

### Owner Responsibilities

As the Product owner, you are responsible for required maintenance and adjustments stated in your Operator's Manual. Failure to perform required maintenance and adjustments can be grounds for disallowing a warranty claim.

### Items and Conditions Not Covered

Not all product failures or malfunctions that occur during the warranty period are defects in materials or workmanship. This warranty does not cover the following:

- Product failures which result from the use of non-Toro replacement parts, or from installation and use of add-on, or modified non-Toro branded accessories and products. A separate warranty may be provided by the manufacturer of these items.
- Product failures which result from failure to perform recommended maintenance and/or adjustments. Failure to properly maintain your Toro product per the Recommended Maintenance listed in the *Operator's Manual* can result in claims for warranty being denied.
- Product failures which result from operating the Product in an abusive, negligent or reckless manner.
- Parts subject to consumption through use unless found to be defective. Examples of parts which are consumed, or used up, during normal Product operation include, but are not limited to, brakes pads and linings, clutch linings, blades, reels, bed knives, tines, spark plugs, castor wheels, tires, filters, belts, and certain sprayer components such as diaphragms, nozzles, and check valves, etc.
- Failures caused by outside influence. Items considered to be outside influence include, but are not limited to, weather, storage practices, contamination, use of unapproved coolants, lubricants, additives, fertilizers, water, or chemicals, etc.

- Normal noise, vibration, wear and tear, and deterioration.
- Normal "wear and tear" includes, but is not limited to, damage to seats due to wear or abrasion, worn painted surfaces, scratched decals or windows, etc.

### Parts

Parts scheduled for replacement as required maintenance are warranted for the period of time up to the scheduled replacement time for that part. Parts replaced under this warranty are covered for the duration of the original product warranty and become the property of Toro. Toro will make the final decision whether to repair any existing part or assembly or replace it. Toro may use remanufactured parts for warranty repairs.

### Note Regarding Deep Cycle Battery Warranty:

Deep cycle batteries have a specified total number of kilowatt-hours they can deliver during their lifetime. Operating, recharging, and maintenance techniques can extend or reduce total battery life. As the batteries in this product are consumed, the amount of useful work between charging intervals will slowly decrease until the battery is completely worn out. Replacement of worn out batteries, due to normal consumption, is the responsibility of the product owner. Battery replacement may be required during the normal product warranty period at owner's expense.

### Maintenance is at Owner's Expense

Engine tune-up, lubrication cleaning and polishing, replacement of Items and Conditions Not Covered filters, coolant, and completing Recommended Maintenance are some of the normal services Toro products require that are at the owner's expense.

### General Conditions

Repair by an Authorized Toro Distributor or Dealer is your sole remedy under this warranty.

**Neither The Toro Company nor Toro Warranty Company is liable for indirect, incidental or consequential damages in connection with the use of the Toro Products covered by this warranty, including any cost or expense of providing substitute equipment or service during reasonable periods of malfunction or non-use pending completion of repairs under this warranty. Except for the Emissions warranty referenced below, if applicable, there is no other express warranty.**

All implied warranties of merchantability and fitness for use are limited to the duration of this express warranty. Some states do not allow exclusions of incidental or consequential damages, or limitations on how long an implied warranty lasts, so the above exclusions and limitations may not apply to you.

This warranty gives you specific legal rights, and you may also have other rights which vary from state to state.

### Note regarding engine warranty:

The Emissions Control System on your Product may be covered by a separate warranty meeting requirements established by the U.S. Environmental Protection Agency (EPA) and/or the California Air Resources Board (CARB). The hour limitations set forth above do not apply to the Emissions Control System Warranty. Refer to the Engine Emission Control Warranty Statement printed in your *Operator's Manual* or contained in the engine manufacturer's documentation for details

### Countries Other than the United States or Canada

Customers who have purchased Toro products exported from the United States or Canada should contact their Toro Distributor (Dealer) to obtain guarantee policies for your country, province, or state. If for any reason you are dissatisfied with your Distributor's service or have difficulty obtaining guarantee information, contact the Toro importer. If all other remedies fail, you may contact us at Toro Warranty Company.