



Count on it.

Parts Catalog

72in Side Discharge Mower
Groundsmaster® 300 Series Traction Unit
Model No. 30722—Serial No. 31000301 and Up

Ordering Replacement Parts

To order replacement parts, please supply the part number, the quantity, and the description of each part desired.

Understanding Reference Numbers

Each identified part in an illustration has a reference number. The reference number for a part also appears in the parts list, along with other information about the part.

This catalog uses two special reference number formats, one to indicate parts in a service assembly and another to indicate the quantity of a given part in an illustration.

Service Assembly Reference Numbers

Parts in service assemblies have reference numbers in the form a:b. The a represents the reference number of the entire service assembly and the b represents a sequential number unique to each part within the service assembly.

For example, a wheel assembly might be identified by reference number 6, the tire by 6:1, the valve by 6:2, and the wheel by 6:3. When you order the assembly identified by reference number 6, you receive all parts identified by reference numbers 6:1, 6:2, and 6:3. However, you may also order any part individually. Reference numbers of this type appear in illustration and in parts lists.

Reference Numbers Indicating Quantity

In an illustration, if a reference number indicates more than one part, the reference number has the form nX y. The n represents the quantity of the part, the X is the multiplication symbol, and the y represents the reference number.

For example, in an illustration, the reference number 2X 37 means that two of the parts identified by reference number 37 are indicated.

List of Abbreviations

AR: as required

ASM: assembly

BBC: blade brake control

BHTF: button head thread forming

CARR: carriage

CCW: counter clockwise

CW: clockwise

DEG: degrees

DPA: Dual Point Adjustment

ECM: electronic control module

EXT: external

FH: flat head

GA: gauge

HD: heavy-duty

HF: hex flange

HH: hex head

HHF: hex head flange

HHFTF: hex head flange thread forming

HJ: hex jam

HLH: hex lag head

HOC: height-of-cut

HSBH: hex socket button head

HSFH: hex socket flat head

HSH: hex socket head

HWH: hex washer head

HWTF: hex washer head thread forming

HYD: hydraulic

LH: left hand

LP: Liquid Propane

NI: nylon insert

NPTF: national pipe thread fine

PFH: phillips flat head

PPH: phillips pan head

PPHTF: phillips pan head thread forming

PRH: phillips round head

PTH: phillips truss head

PTO: power-take-off

RH: right hand

ROPS: roll-over protection system

RRB: rear roller brush

SFH: slotted fillister head

SHH: slotted hex head

SHWH: slotted hex washer head

SPH: slotted pan head

SQH: square head

SRH: slotted round head

STD: standard

TAP: self tapping

TTH: torx truss head

Contents

Deck Assembly	4
Center Spindle Assembly No. 95-3090.....	6
Right Hand Spindle Assembly No. 95-3095.....	7
Left Hand Spindle Assembly No. 95-3089	8
Carrier Frame and Cover Assembly	9
Pneumatic Tire and Wheel Assembly No. 54-8810	11
Driveshaft and Gearbox Assembly	12
Driveshaft Assembly No. 93-9996.....	13
Gear Box Assembly No. 108-1370	14
Attachments and Accessories	15

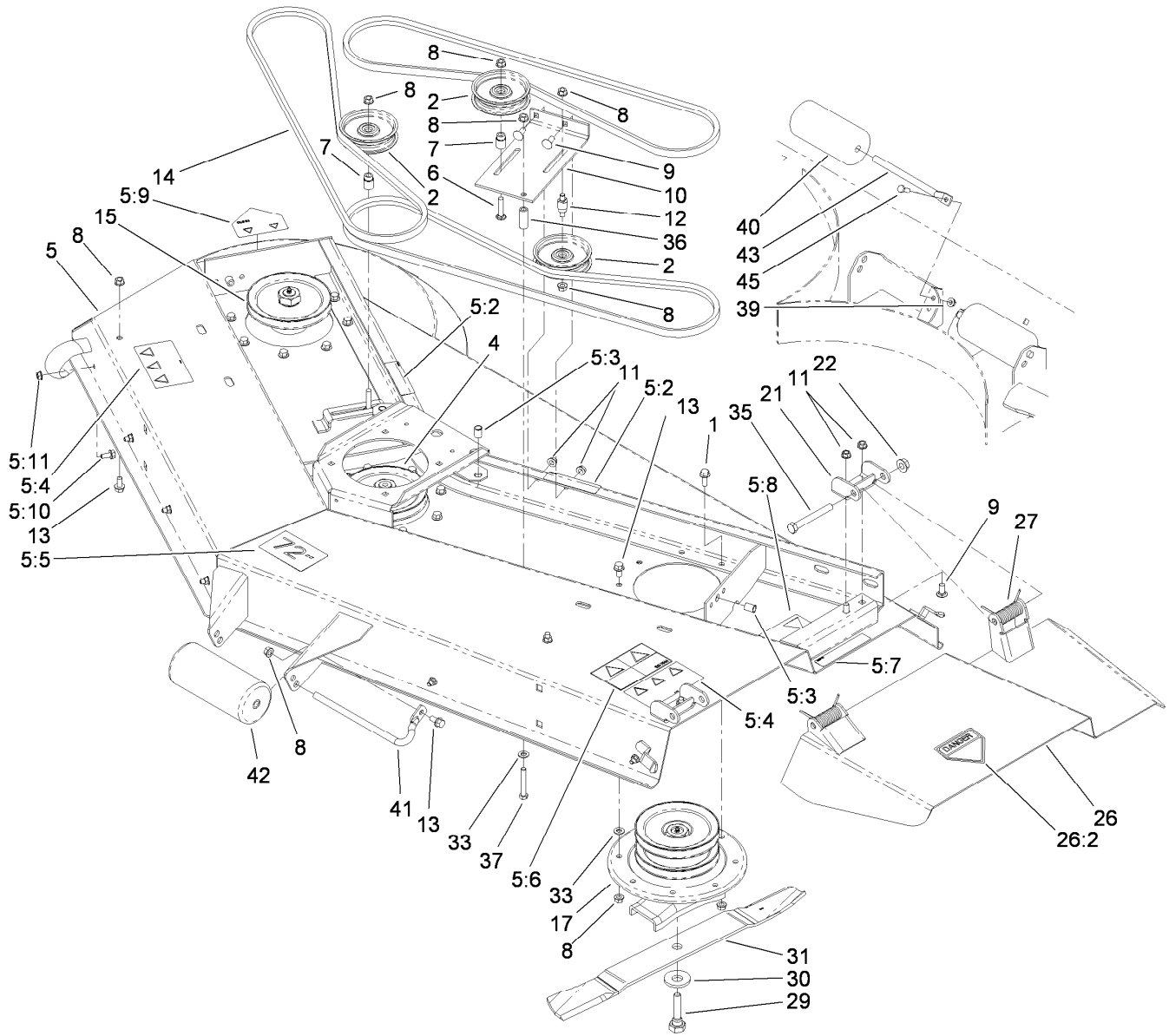

Deck Assembly

Ref.	Part Number	Qty.	Description	Ref.	Part Number	Qty.	Description
1	3234-11	4	Screw-HHF	12	26-1850	1	Stud-Idler
2	26-1840	3	Pulley-Idler	13	3234-1	24	Screw-HHF
4	95-3090	1	Center Spindle ASM	14	21-0890	3	V-Belt
5	93-7181	1	72 Inch Side Discharge Deck ASM	15	95-3095	1	RH Spindle ASM
5:2	100-6578	2	Decal-Danger	17	95-3089	1	LH Spindle ASM
5:3	3290-469	4	Nut-Clinch	21	51-1530-01	2	Hinge Bracket ASM
5:4	107-2908	2	Decal-Danger, Combination	22	32128-23	2	Nut-HF
5:5	57-0280	1	Decal	26	119-8025	1	Deflector
5:6	105-7844	1	Decal-Warning	26:2	43-8480	1	Decal-Danger
5:7	107-2916	1	Decal-Warning	27	51-1550	2	Spring
5:8	93-7817	1	Decal-Torque, Blade Bolt	29	26-1820	3	Capscrew
5:9	106-6753	1	Decal-Danger, Ce	30	26-1990	3	Washer-Belleville
5:10	3234-5	7	Screw-HHF	31	106-4353-03	3	Blade-Atomic, 25 Inch, LH
5:11	32128-20	7	Nut-HF	31	23-2410-03	3	Blade-High Sail, 25 Inch, LH
6	3231-29	2	Screw-CARR	31	29-5530-03	3	Blade-Standard, 25 Inch, LH
7	26-1860	2	Spacer-Idler Pulley	33	3256-24	2	Washer-Flat
8	32128-21	33	Nut-HF	35	325-17	2	Screw-HH
9	3231-27	6	Screw-CARR	36	26-1880	1	Spacer-Idler Mount
10	26-1870-03	1	Mount-Idler	37	323-12	1	Screw-HH
11	3290-357	6	Nut-HHF, Whiz	39	32128-25	2	Nut-HF

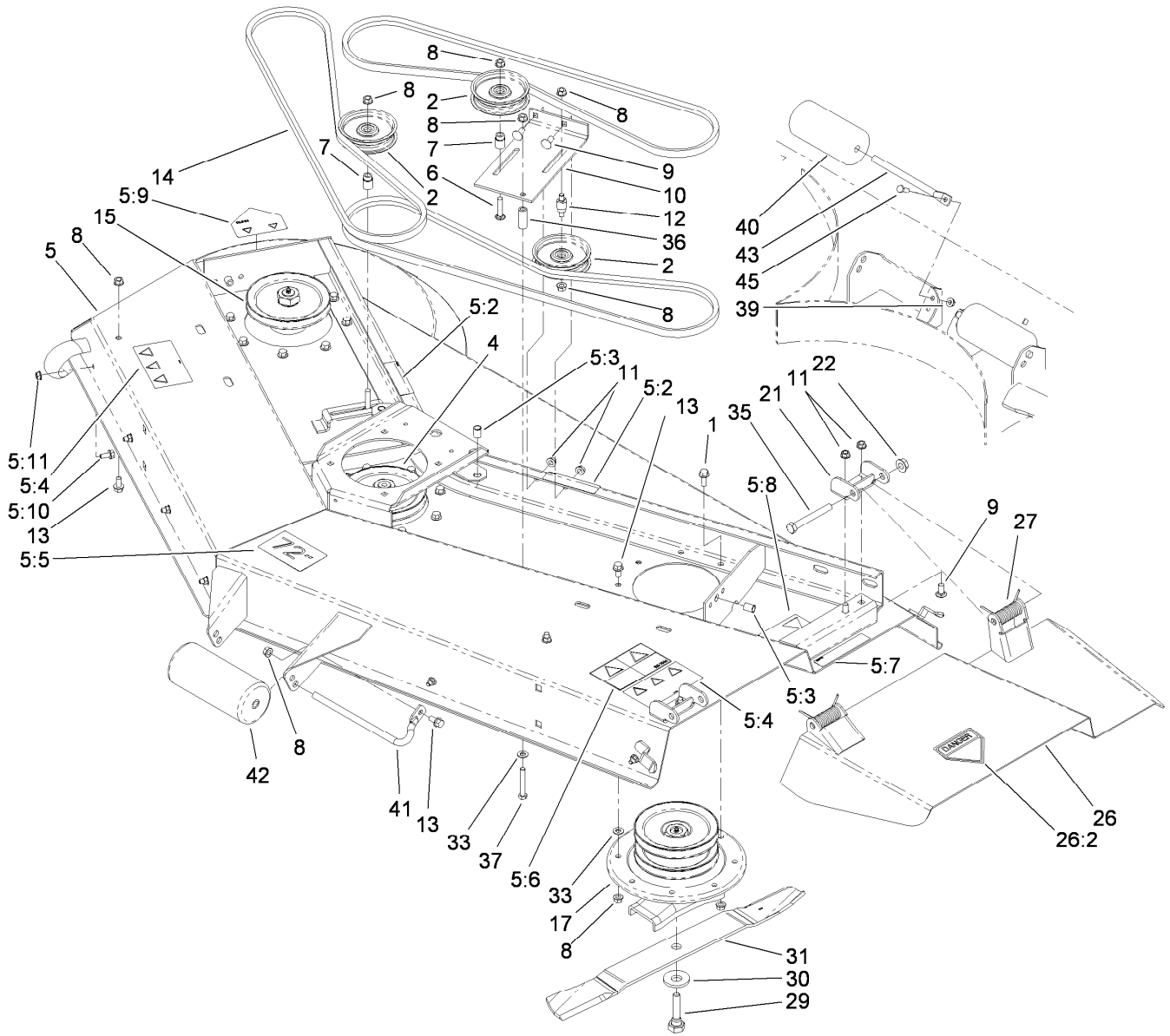

Deck Assembly (continued)

<i>Ref.</i>	<i>Part Number</i>	<i>Qty.</i>	<i>Description</i>	<i>Ref.</i>	<i>Part Number</i>	<i>Qty.</i>	<i>Description</i>
40	36-1740	2	Roller-Deck	43	62-4480	2	Rod-Roller
41	68-6840	1	Shaft-Roller	45	322-4	2	Screw-HH
42	68-6710	1	Roller				

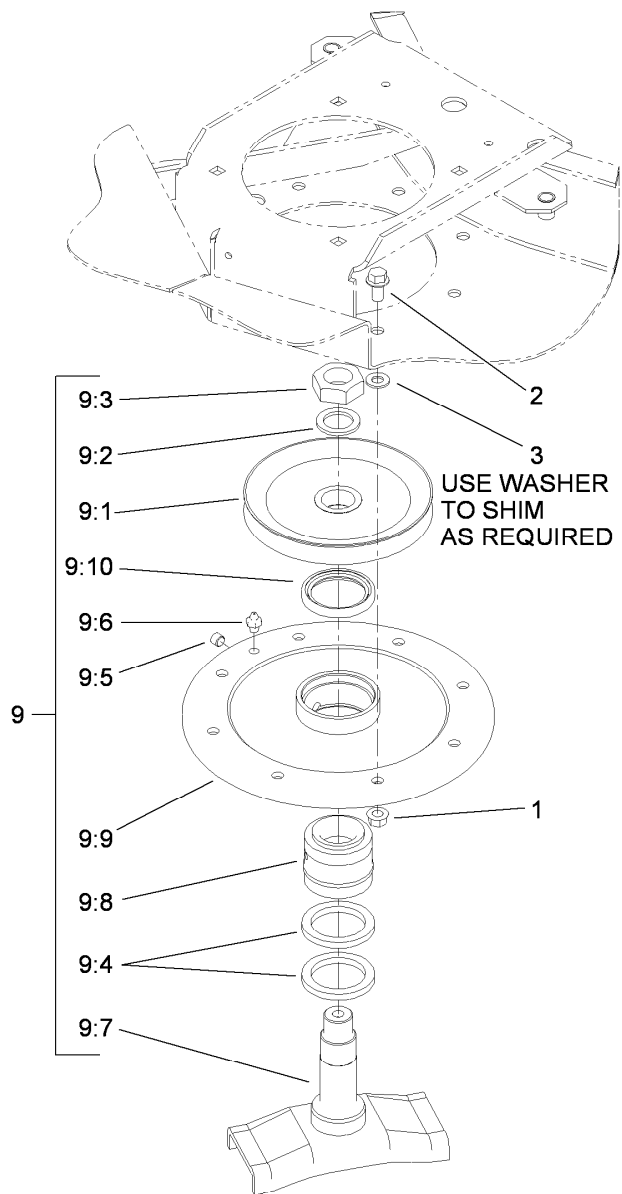

Center Spindle Assembly No. 95-3090

Ref.	Part Number	Qty.	Description
1	32128-21	8	Nut-HF
2	3234-1	8	Screw-HHF
3	3256-24	8	Washer-Flat
9		1	Center Spindle ASM ●
9:1	26-1760	1	Pulley And Hub ASM
9:2	3-8514	1	Washer-Thrust
9:3	3296-49	1	Nut-Lock, NI
9:4	253-138	2	Seal-Oil
9:5	285-17	2	Plug-Pipe
9:6	302-2	1	Fitting-Grease
9:7	84-5370	1	Spindle
9:8	49-8320	1	Bearing ASM
9:9	84-2080	1	Housing-Spindle, Center
9:10	253-154	1	Seal-Oil

● Not serviced separately

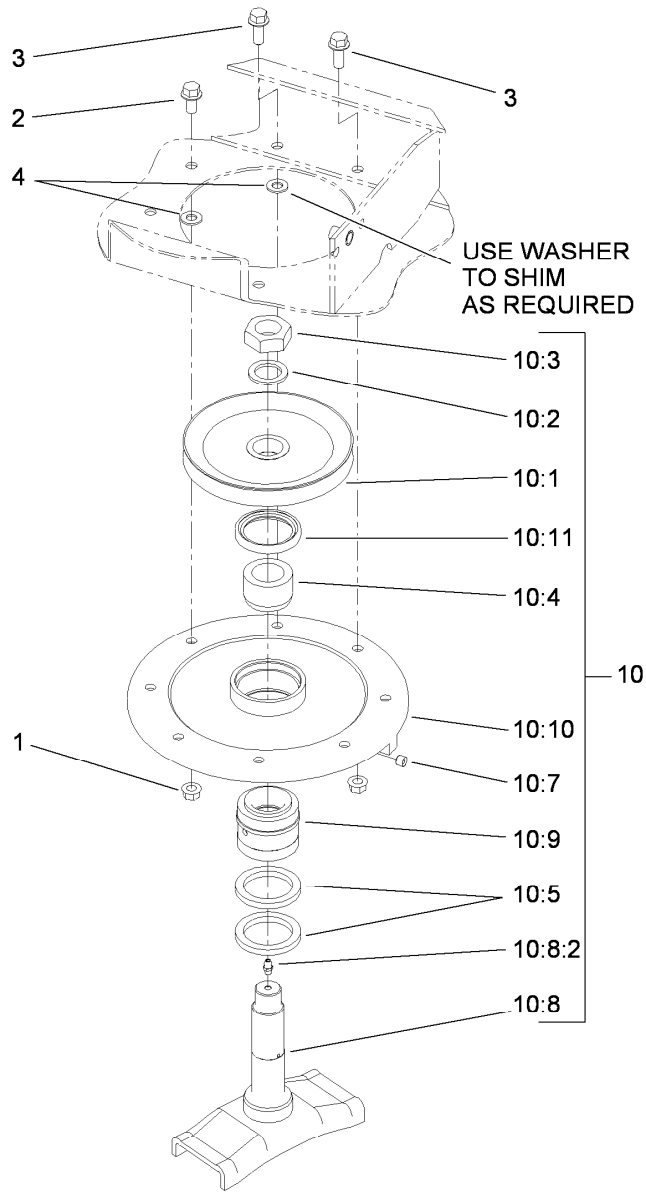

Right Hand Spindle Assembly No. 95-3095

<i>Ref.</i>	<i>Part Number</i>	<i>Qty.</i>	<i>Description</i>	<i>Ref.</i>	<i>Part Number</i>	<i>Qty.</i>	<i>Description</i>
1	32128-21	8	Nut-HF	10:4	84-2090	1	Spacer-Spindle, RH
2	3234-1	6	Screw-HHF	10:5	253-138	2	Seal-Oil
3	3234-11	2	Screw-HHF	10:7	285-17	1	Plug-Pipe
4	3256-24	8	Washer-Flat	10:8	110-8537	1	Spindle ASM
10		1	RH Spindle ASM ●	10:8:2	302-5	1	Fitting-Grease
10:1	26-1760	1	Pulley And Hub ASM	10:9	49-8320	1	Bearing ASM
10:2	3-8514	1	Washer-Thrust	10:10	84-2020	1	Housing-Spindle
10:3	3296-49	1	Nut-Lock, NI	10:11	253-154	1	Seal-Oil

● Not serviced separately

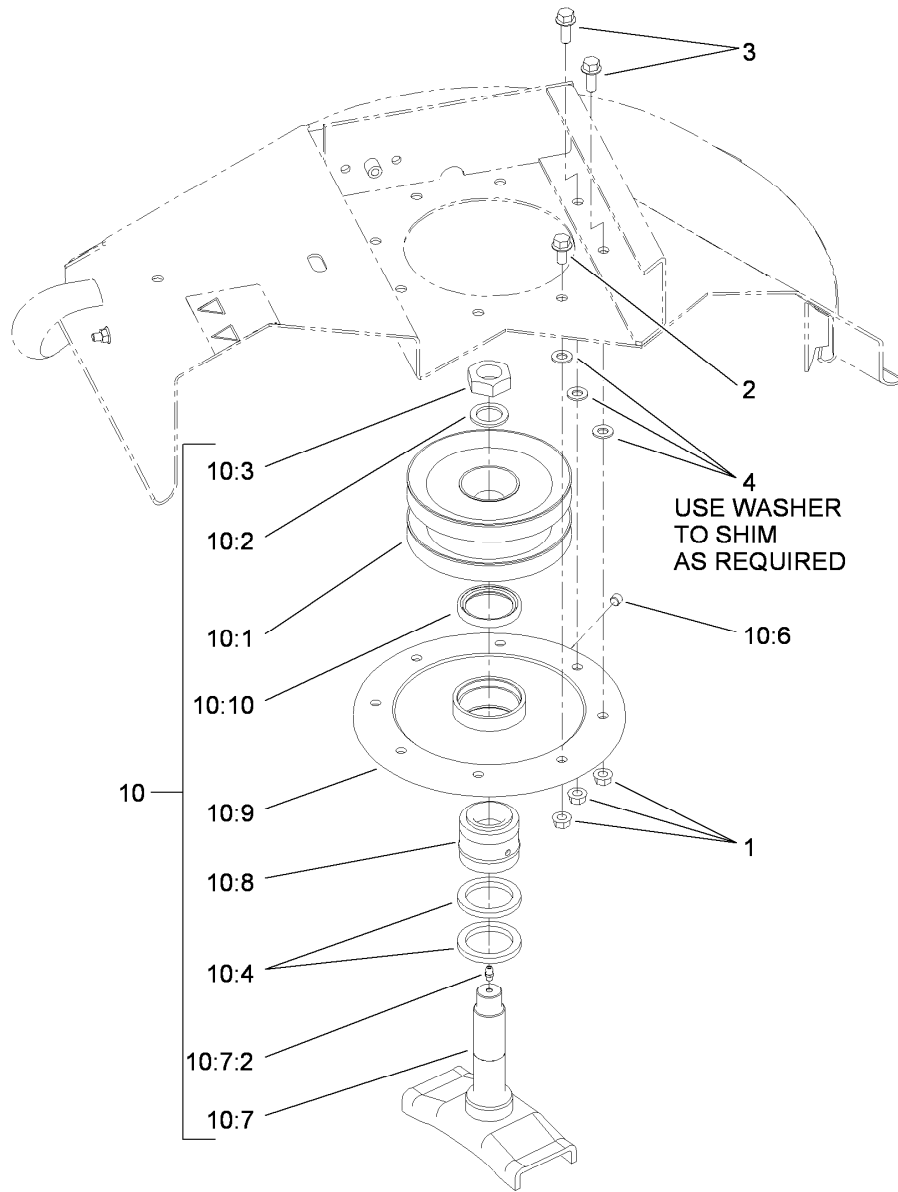

Left Hand Spindle Assembly No. 95-3089

Ref.	Part Number	Qty.	Description
1	32128-21	8	Nut-HF
2	3234-1	6	Screw-HHF
3	3234-11	2	Screw-HHF
4	3256-24	8	Washer-Flat
10		1	LH Spindle ASM ●
10:1	84-2060	1	Pulley And Hub ASM
10:2	3-8514	1	Washer-Thrust
10:3	3296-49	1	Nut-Lock, NI
10:4	253-138	2	Seal-Oil
10:6	285-17	1	Plug-Pipe
10:7	110-8537	1	Spindle ASM
10:7:2	302-5	1	Fitting-Grease
10:8	49-8320	1	Bearing ASM
10:9	84-2020	1	Housing-Spindle
10:10	253-154	1	Seal-Oil

● Not serviced separately

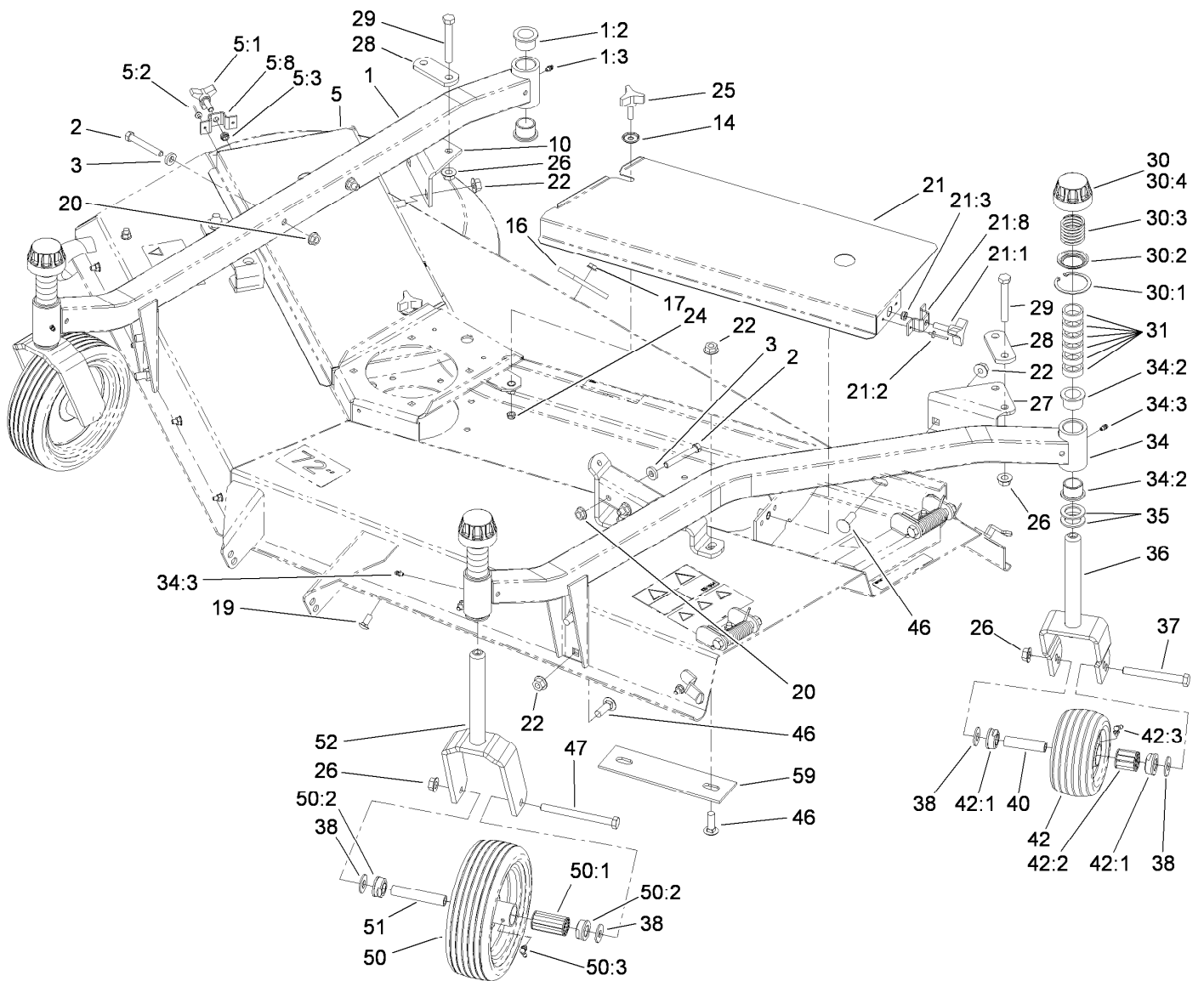

Carrier Frame and Cover Assembly

Ref.	Part Number	Qty.	Description	Ref.	Part Number	Qty.	Description
1	26-1490	1	RH Castor Arm ASM	21:3	3296-59	1	Nut-Lock, NI
1:2	94-1291	4	Bushing	21:8	66-1260	1	Bracket-Knob
1:3	302-5	2	Fitting-Grease	22	32128-49	12	Nut-HHF
2	324-12	4	Screw-HH	24	3296-59	2	Nut-Lock, NI
3	66-6480	4	Washer	25	27-4570	4	Knob-Seat
5	14-5869	1	RH Cover ASM	26	32128-23	8	Nut-HF
5:1	27-4570	1	Knob-Seat	27	39-7450-01	1	LH Clamp Bracket
5:2	3269-5	2	Rivet-Pop	28	39-3330-01	2	Plate-Castor Arm Clamp
5:3	3296-59	1	Nut-Lock, NI	29	325-14	4	Screw-HH
5:8	66-1260	1	Bracket-Knob	30	92-8862	4	HOC Cap ASM
10	39-3340-01	1	Bracket-Arm Clamp	30:1	92-5581	1	Ring-Retaining
14	66-6310	2	Washer-Cup	30:2	92-5583	1	Washer-Cap
16	21-3770-01	1	Lift Strap-Deck, Rr	30:3	92-5584	1	Spring-Compression
17	3290-357	2	Nut-HHF, Whiz	30:4	92-8861	1	Cap-HOC
19	3231-27	2	Screw-CARR	31	63-0070	24	Spacer
20	32128-42	4	Nut-HF	34	26-1430	1	Castor Arm ASM, LH
21	14-5879	1	LH Cover ASM	34:2	94-1291	4	Bushing
21:1	27-4570	1	Knob-Seat	34:3	302-5	2	Fitting-Grease
21:2	3269-5	2	Rivet-Pop	35	3-6781	8	Washer-Thrust

● Optional Equipment

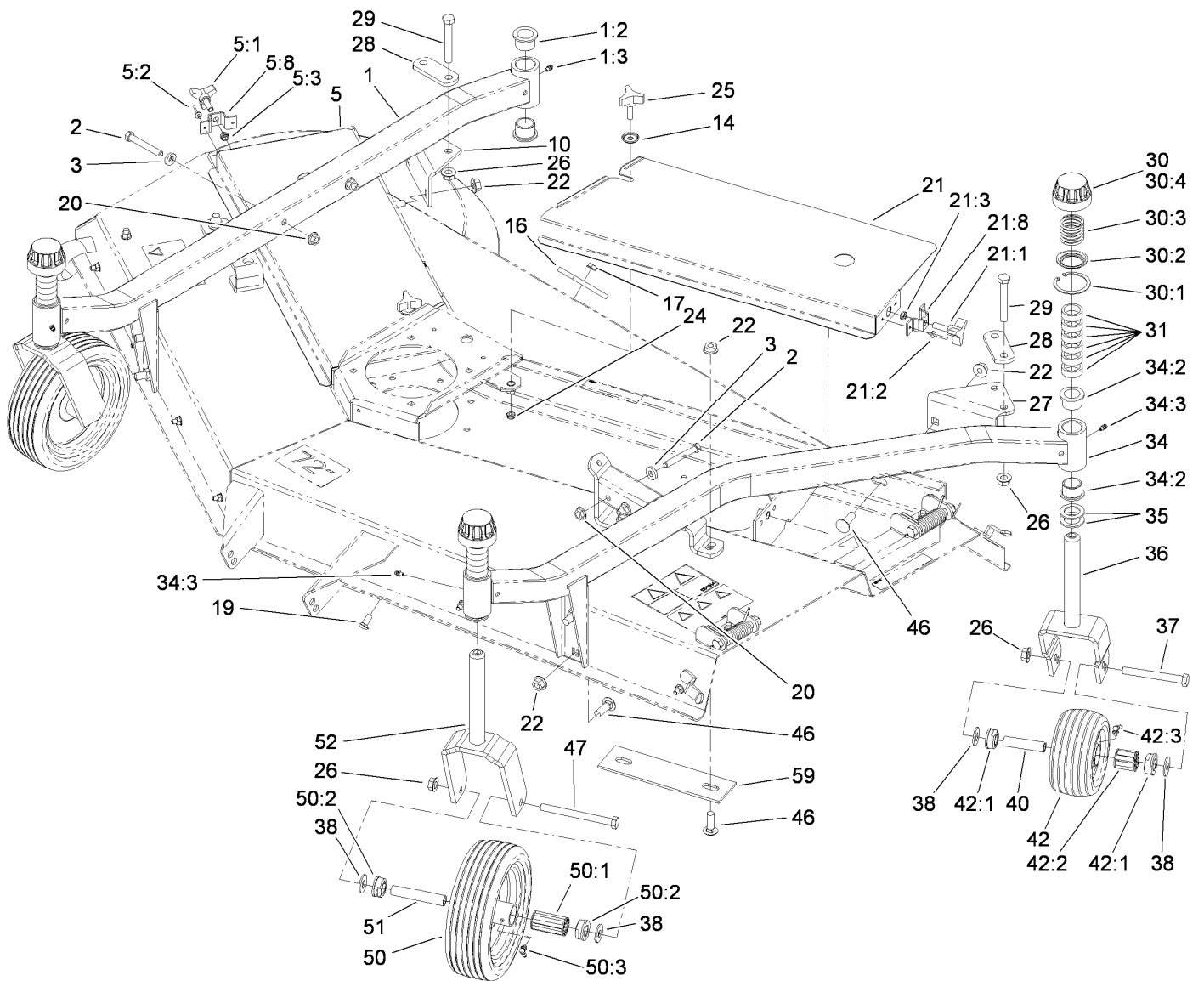

Carrier Frame and Cover Assembly (continued)

Ref.	Part Number	Qty.	Description	Ref.	Part Number	Qty.	Description
36	75-9680-01	2	Castor Fork ASM	50	54-8810	2	10In Pneumatic Castor Wheel ASM ●
37	325-18	2	Screw-HH	50	92-1655	2	10-Inch Castor Wheel ASM
38	3256-6	8	Washer-Flat	50:1	83-4740	1	Bearing
40	63-1770	2	Spanner	50:2	62-5580	2	Bearing-Outside
42	63-8400	2	Caster Wheel ASM	50:3	302-40	1	Fitting-Grease
42:1	62-5580	2	Bearing-Outside	51	62-4340	2	Spanner
42:2	63-8580	1	Bearing-Roller	52	26-1530-01	2	Castor Fork ASM
42:3	302-40	1	Fitting-Grease	59	26-1190-01	2	Plate-Reinforcement
46	3233-2	12	Screw-CARR				
47	325-22	2	Screw-HH				

● Optional Equipment

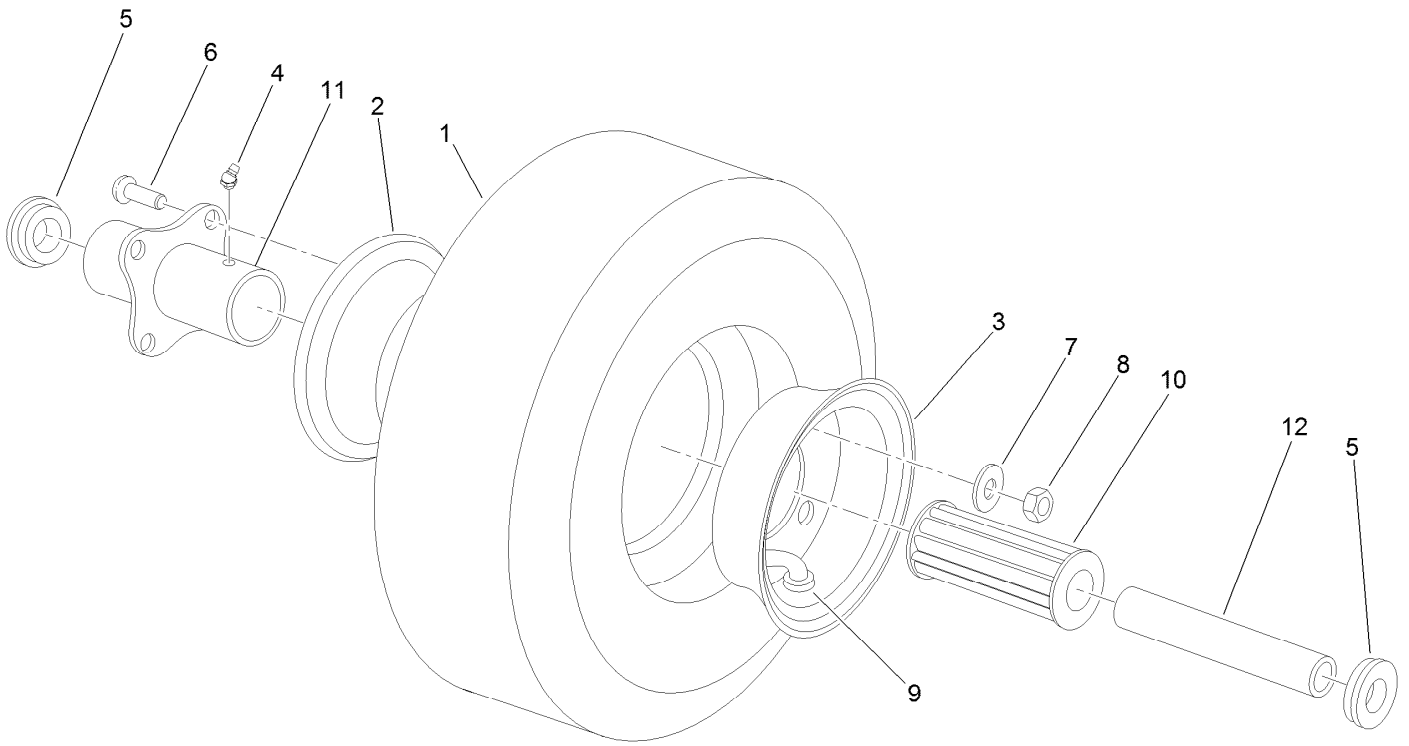

Pneumatic Tire and Wheel Assembly No. 54-8810

<i>Ref.</i>	<i>Part Number</i>	<i>Qty.</i>	<i>Description</i>
1	54-8960	1	Tire-10 Inch (2-Ply)
2	54-8910	1	Wheel Half-Female
3	54-8900	1	Wheel Half-Male
4	302-61	1	Fitting-Grease
5	54-8930	2	Retainer
6	54-8890	4	Wheel Bolt
7	3253-4	4	Washer-Lock
8	3217-6	4	Nut-Hex
9	54-8950	1	Tube
10	54-8940	1	Roller Bearing
11	54-8920	1	Hub-Centered
12	55-7080	1	Spanner-Bushing

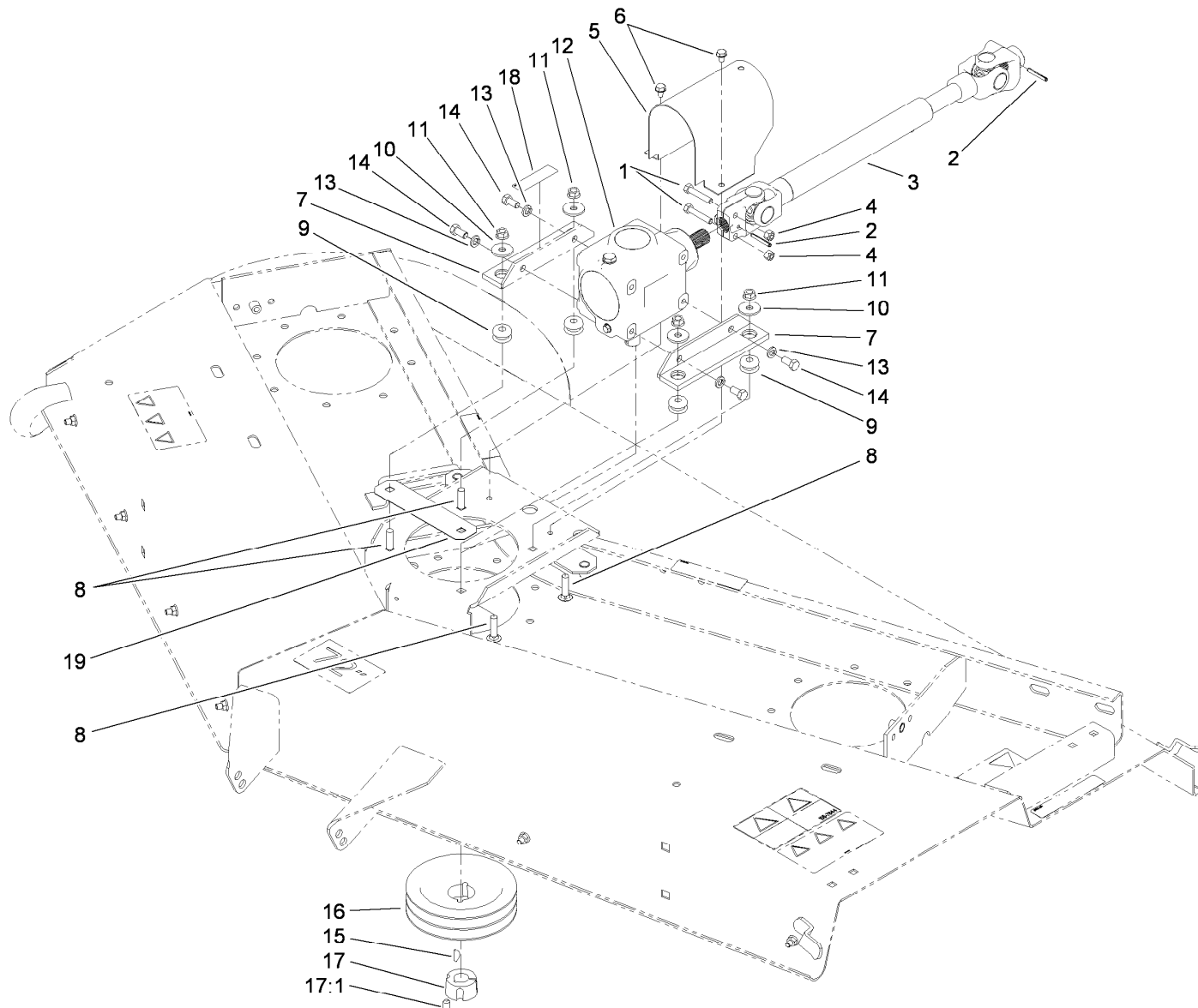

Driveshaft and Gearbox Assembly

<i>Ref.</i>	<i>Part Number</i>	<i>Qty.</i>	<i>Description</i>	<i>Ref.</i>	<i>Part Number</i>	<i>Qty.</i>	<i>Description</i>
1	322-9	2	Screw-HH	11	32128-21	4	Nut-HF
2	32121-34	2	Pin-Roll	12	108-1370	1	Gearbox Replacement Kit
3	93-9996	1	Driveshaft ASM	13	3253-21	4	Washer-Lock
4	3296-29	2	Nut-Lock, NI	14	323-4	4	Screw-HH
5	93-9838-03	1	Shroud-Shaft, Drive	15	3257-5	1	Key-Woodruff
6	32104-82	2	Screw-HHF	16	26-1400-03	1	Pulley-Deck
7	68-8560-03	2	Bracket-Gearbox	17	23-1640	1	Bushing-Taperlock
8	3231-26	4	Screw-CARR	17:1	3247-4	2	Screw-Set
9	63-9750	4	Mount	18	93-6697	1	Decal-Lube
10	63-8410	4	Washer	19	68-9890-01	1	Cover-Gearbox, Front

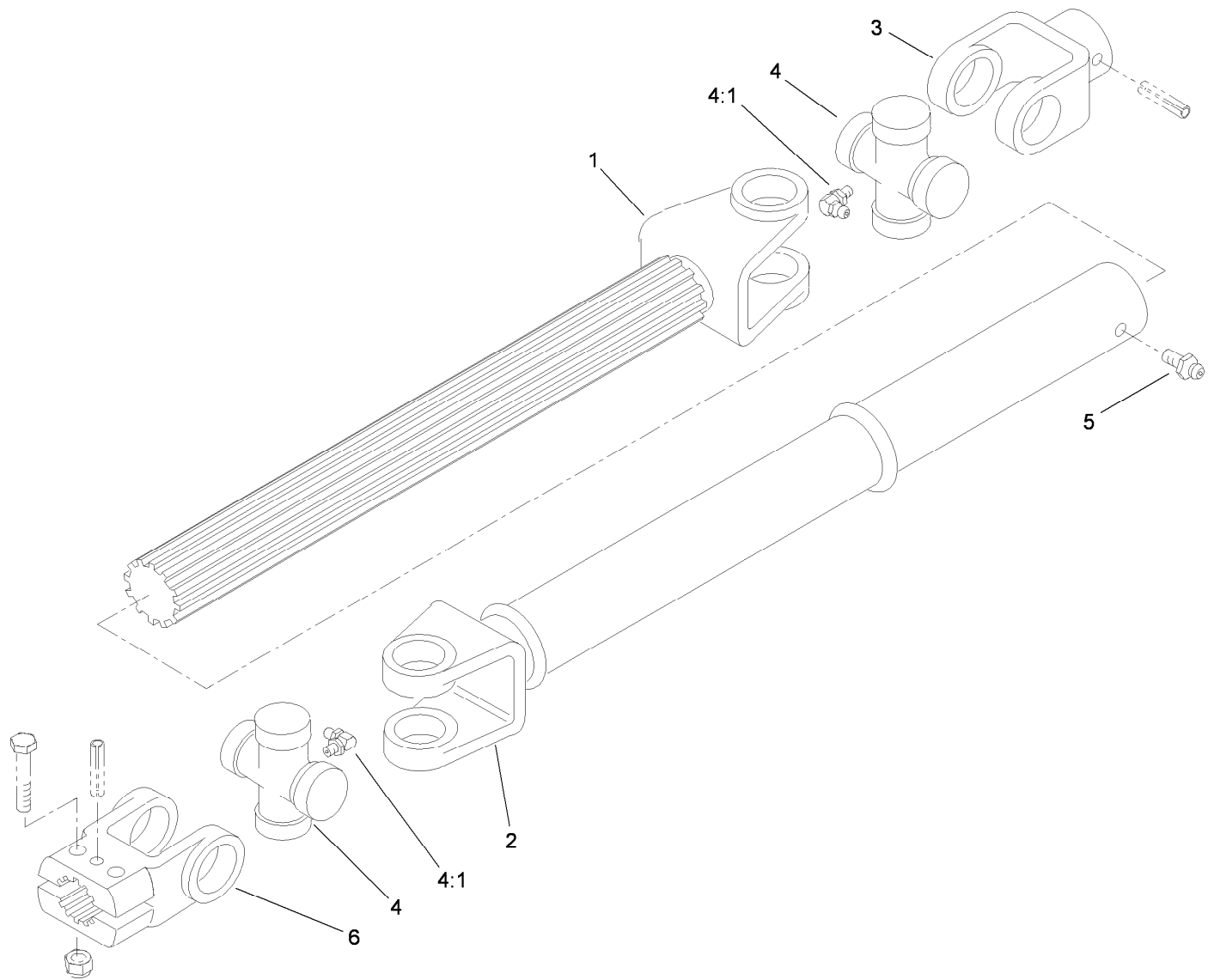

Driveshaft Assembly No. 93-9996

<i>Ref.</i>	<i>Part Number</i>	<i>Qty.</i>	<i>Description</i>
1	93-9963	1	Shaft-Yoke, Slip
2	93-9966	1	Tube-Slip Yoke
3	62-3800	1	Yoke-End
4	54-9180	2	U-Joint Kit
4:1	62-3820	1	Fitting-Grease
5	302-58	1	Fitting-Straight
6	54-9040	1	Yoke-End

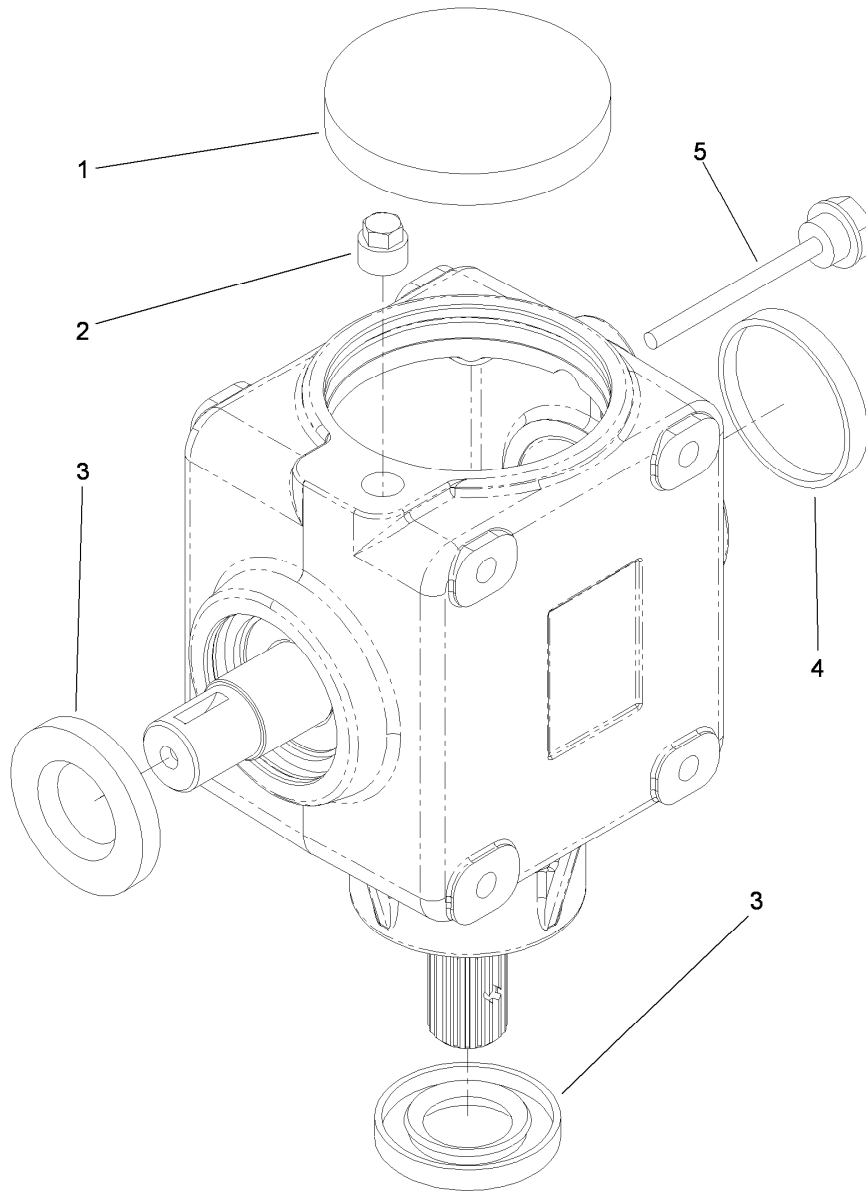

Gear Box Assembly No. 108-1370

<i>Ref.</i>	<i>Part Number</i>	<i>Qty.</i>	<i>Description</i>
1	107-2932	1	Cap-Oil
2	107-2933	1	Plug
3	117-9247	2	Seal
4	107-2935	1	Cap-Oil
5	107-2936	1	Plug-Filler, Dipstick

Attachments and Accessories

For 30722 72in Side Discharge Mower Groundsmaster 300 Series Traction Unit

Product Name	Model/Part
25in LH Atomic Blade ASM.....	106-4354
CE Kit	108-1381
Blade Service Pack, 25in	108-1454
Blade-High Sail, 25in, LH.....	23-2410-03
Spacer	27-1040
10in Pneumatic Castor Wheel Asm	54-8810
PTO-Male Half	92-4663
10in Foam Filled Wheel	93-5973
10in Caster Wheel Kit	95-3082
Castor Wheel Kit.....	95-3084
72in RD Wheel Set Kit	95-3086
Blade And Belt Kit.....	95-3087
LH Spindle Kit.....	95-3089
Center Spindle Kit.....	95-3090
High Sail Blade and Belt Kit	95-3094
RH Spindle Kit	95-3095



Count on it.