



1800 Power Curve® Snowthrower

Model No. 38381—Serial No. 311000001 and Up

Operator's Manual

IMPORTANT SAFETY INSTRUCTIONS

When using an electrical appliance, basic precautions should always be followed, including the following:

READ ALL INSTRUCTIONS BEFORE USING THIS APPLIANCE

WARNING—To reduce the risk of fire, electric shock, or injury, follow these safety instructions.

It is essential that you or any other operator of the appliance read and understand the contents of this manual before operating the appliance. Pay particular attention to the safety alert symbol  which means CAUTION, WARNING, or DANGER—personal safety instruction. Read and understand the instruction because it has to do with safety. Failure to comply with these instructions may result in personal injury, risk of fire, or electrical shock.

Replacement parts—When servicing the appliance, use only identical replacement parts. The power cord and switch used on this machine cannot be replaced. If the cord or switch become damaged, dispose of the machine.

Do not use the appliance on graveled surface unless it is adjusted for such a surface in accordance with the *Operator's Manual*.

Keep children and bystanders away—All visitors should be kept at a distance from the work area.

Dress properly—Do not wear loose clothing or jewelry. They can be caught in moving parts.

Wear rubber boots when operating the appliance.

Operating the appliance in the hand-held position is unsafe, except in accordance with the special instructions for such use provided in the *Operator's Manual*.

Warning—To prevent electric shock, use the appliance only with an extension cord suitable for outdoor use.

Extension cords—To prevent the appliance cord and the extension cord from disconnecting during operation, connect the extension cord to the appliance as shown in Figure 9.

Avoid accidental starting—Do not carry the appliance with your finger on the switch. Ensure that the switch is off when plugging in the appliance.

If the appliance cord is damaged in any manner while it is plugged in, disconnect the extension cord from the wall receptacle and contact an Authorized Service Dealer.

Do not abuse the cord—Never carry the appliance by its cord or yank on the extension cord to disconnect the appliance from the receptacle. Keep the cord from heat, oil, and sharp edges.

Keep hands away from moving parts.

Keep guards in place and in working order.

Do not force the appliance—It will perform better and safer at the rate for which it was designed.

Do not overreach—Watch your footing and keep your balance at all times.

If the appliance strikes a foreign object, follow these steps:

- Immediately release the control bar to stop the appliance.
- Unplug the power cord.
- Inspect for damage.
- Repair any damage before starting and operating the appliance.

Disconnect the appliance—Disconnect the appliance from the power supply when not in use, before servicing, when changing accessories, etc.

Store an idle appliance indoors. When the appliance is not in use, it should be stored indoors in a dry, secured place out of the reach of children.

Maintain the appliance with care—Follow instructions for changing accessories.

This appliance meets or exceeds the B71.3 specifications of the American National Standards Institute in effect at the time of production.

Read and understand the contents of this manual before you start the motor.

 **This is the safety alert symbol. It is used to alert you to potential personal injury hazards. Obey all safety messages that follow this symbol to avoid possible injury or death.**

Improperly using or maintaining this appliance could result in injury or death. To reduce this potential, comply with the following safety instructions.

This appliance is capable of amputating hands and feet and of throwing objects. Failure to observe the following safety instructions could result in serious injury.

Training

- Read, understand, and follow all instructions on the appliance and in the manual(s) before operating this appliance. Be thoroughly familiar with all the controls and the proper use of the appliance. Know how to stop the appliance and disengage the controls quickly.
- Never allow children to operate the appliance. Never allow adults to operate the appliance without proper instruction.
- Keep the area of operation clear of all persons, particularly small children.
- Exercise caution to avoid slipping or falling.

Preparation

- Thoroughly inspect the area where the appliance is to be used and remove all doormats, sleds, boards, wires, and other foreign objects.

- Do not operate the appliance without wearing adequate winter garments. Avoid loose fitting clothing that can get caught in moving parts. Wear footwear that will improve footing on slippery surfaces.
- Do not attempt to clear snow from a gravel or crushed rock surface. This appliance is intended for use only on paved surfaces.
- Never attempt to make any adjustments while the motor is running (except when specifically recommended by manufacturer).
- Always wear safety glasses or eye shields during operation or while performing an adjustment or repair to protect eyes from foreign objects that may be thrown from the appliance.

- Maintain or replace safety and instruction labels as needed.
- Run the appliance for a few minutes after throwing snow to prevent freeze-up of the rotor blades.

SAVE THESE INSTRUCTIONS

Safety and Instructional Decals

Operation

- Do not put hands or feet near or under rotating parts. Keep clear of the discharge opening at all times.
- Exercise extreme caution when operating on or crossing gravel drives, walks, or roads. Stay alert for hidden hazards or traffic.
- After striking a foreign object, stop the motor, unplug the extension cord, remove the key, and thoroughly inspect the appliance for any damage. Repair any damage before starting and operating the appliance.
- If the appliance should start to vibrate abnormally, stop the motor and check immediately for the cause. Vibration is generally a warning of trouble.
- Stop the motor, remove the key, and unplug the appliance whenever you leave the operating position, before unclogging the rotor blade housing or discharge chute, and when making any repairs, adjustments, or inspections.
- When cleaning, repairing, or inspecting the appliance, stop the motor, remove the key, unplug the appliance, and ensure that the rotor blades and all moving parts have stopped.
- Exercise extreme caution when operating on slopes.
- Never operate the appliance without proper guards and other safety protective devices in place and working.
- Never direct the discharge toward people or areas where property damage can occur. Keep children and others away.
- Do not overload the capacity of the appliance by attempting to clear snow at too fast a rate.
- Look behind and use care when backing up with the appliance.
- Never operate the appliance without good visibility or light. Always be sure of your footing, and keep a firm hold on the handle. Walk; never run.

Clearing a Clogged Discharge Chute

Hand contact with the rotating rotor blades inside the discharge chute is the most common cause of injury associated with snowthrowers. Never use your hand to clean out the discharge chute.

To clear the chute:

- **Shut the motor off, remove the key, and unplug the extension cord from the machine!**
- Wait 10 seconds to be sure the rotor blades have stopped rotating.
- Always use a clean-out tool, not your hands.

Maintenance and Storage

- Check all fasteners at frequent intervals for proper tightness to ensure that the appliance is in safe working condition.
- Always refer to the *Operator's Manual* for important details if the appliance is to be stored for an extended period.



Safety decals and instructions are easily visible to the operator and are located near any area of potential danger. Replace any decal that is damaged or lost.

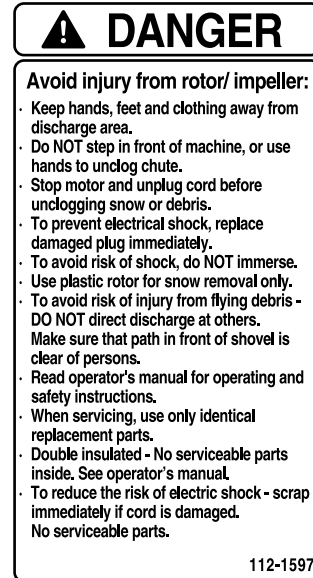

112-1597

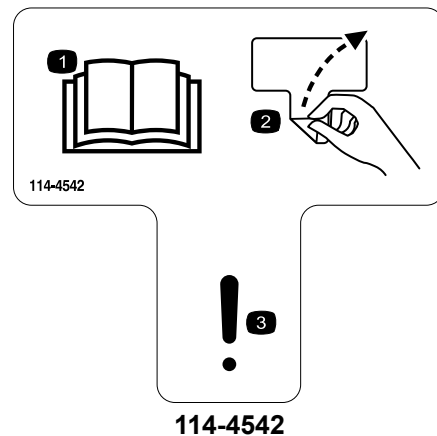

1. Read the *Operator's Manual*.
2. Remove decal
3. Warning



114-9034

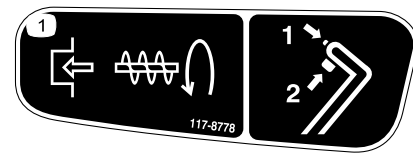

117-8778

1. To engage the rotor, press the interlock switch on the handle.

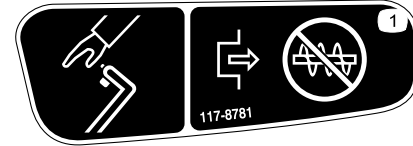

117-8781

1. To disengage the rotor, release the interlock switch on the handle.

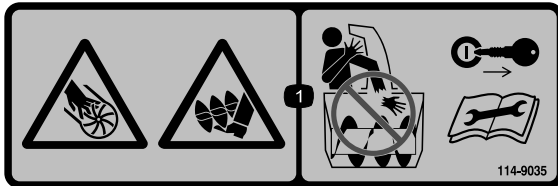

114-9035

1. Cutting/dismemberment hazard, rotor—do not place your hand in the chute; remove the ignition key and read the instructions before servicing or performing maintenance.

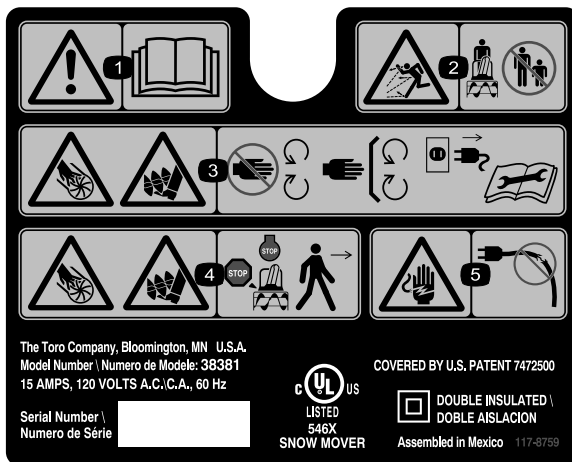

117-8760

1. Warning—read the *Operator's Manual*.
2. Thrown object hazard—keep bystanders a safe distance from the machine.
3. Cutting/dismemberment hazard, rotor—stay away from moving parts, keep all guards and shields in place; disconnect power cord from power source and read the instructions before servicing or performing maintenance.
4. Cutting/dismemberment hazard, rotor—stop the engine and machine before leaving the machine.
5. Electric shock hazard—do not use a damaged power cord.

Setup

Note: Determine the left and right sides of the machine from the normal operating position.

Installing the Upper Handle

1. Remove the handle knobs, oval bolts, and curved washers from the lower handle.
2. Install the upper handle to the lower handle of the machine with the handle knobs, curved washers, and oval bolts as shown in Figure 1.

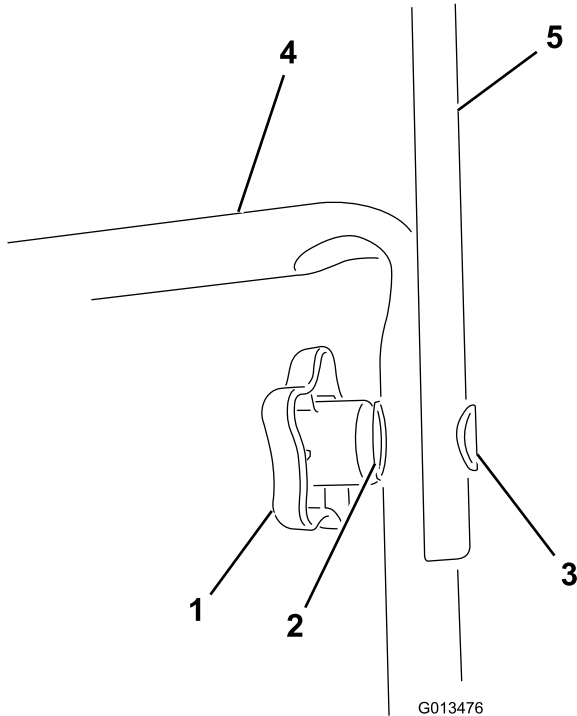

Figure 1

- | | |
|----------------------|-----------------|
| 1. Handle knob (2) | 4. Lower handle |
| 2. Curved washer (2) | 5. Upper handle |
| 3. Oval bolt (2) | |

Note: Ensure that the power cord attached to the machine is routed over the lower handle and to the **inside** of the handle assembly.

3. Tighten the handle knobs firmly by hand.
4. Attach the cord guide to the handle (Figure 2).

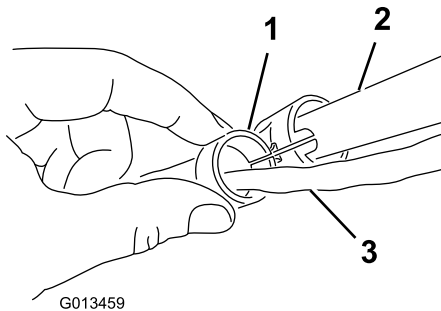

Figure 2

- | | |
|---------------|---------|
| 1. Cord guide | 3. Cord |
| 2. Handle | |

Installing the Chute Control Rod

1. Position the discharge chute so that it faces forward.

NOTICE! Align the arrow on the discharge chute with the arrow on the housing (Figure 3).

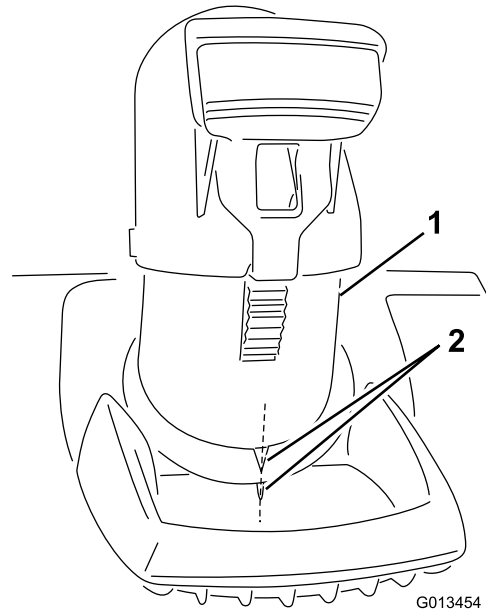

Figure 3

- | | |
|--------------------|---------------------|
| 1. Discharge chute | 2. Align the arrows |
|--------------------|---------------------|

2. Insert the end of the chute control rod through the keyed hole in the bracket that is attached to the top of the lower handle (Figure 4).

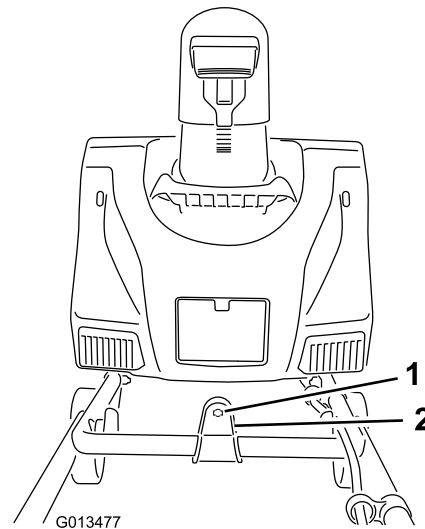

Figure 4

- | | |
|---------------|------------|
| 1. Keyed hole | 2. Bracket |
|---------------|------------|

3. Remove the decal that covers the keyed hole in the back of the housing (Figure 5).

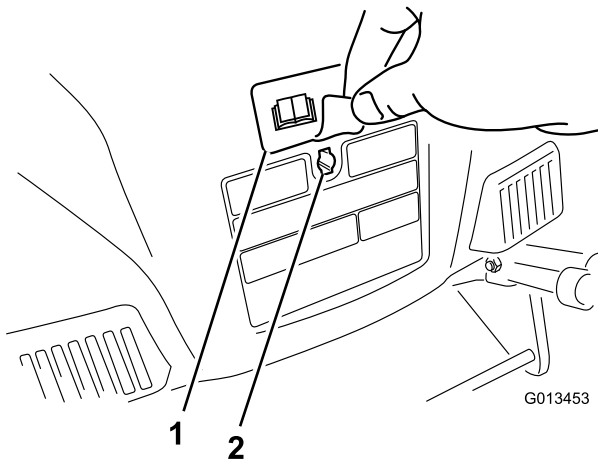

Figure 5

1. Decal
2. Keyed hole

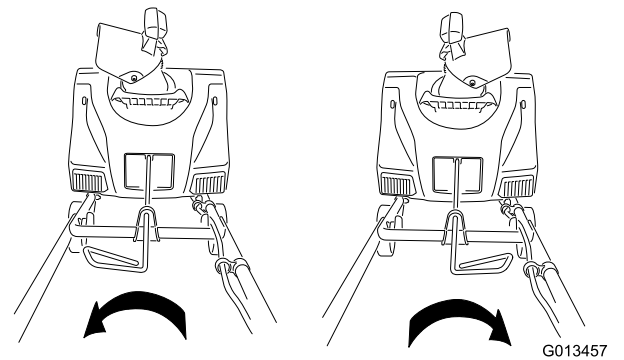

Figure 7

4. Ensure that the handle of the chute control rod points upward (Figure 6), and insert the rod into the keyed hole in the back of the housing.

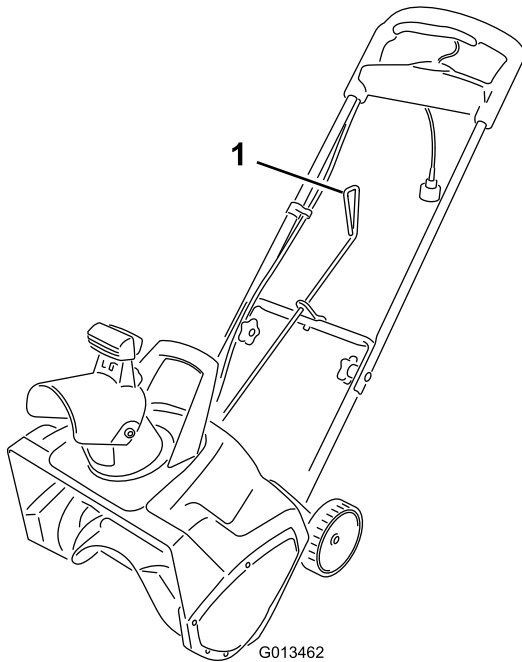

Figure 6

1. Handle on the chute control rod

5. Firmly push the rod into the keyed hole in the back of the housing until it snaps into place.
6. Move the handle on the chute control rod to ensure that it moves in the same direction as the chute (Figure 7).

Operation

Product Overview

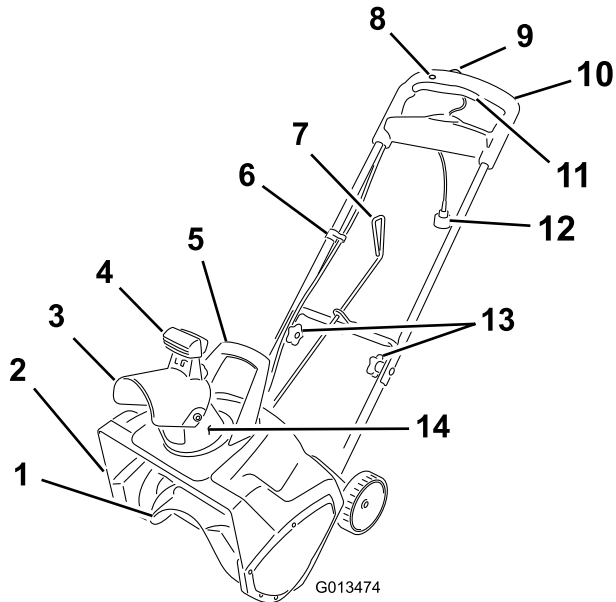

Figure 8

- | | |
|----------------------------|-----------------------|
| 1. Rotor blades | 8. Interlock button |
| 2. Belt cover (not shown) | 9. Key |
| 3. Chute deflector | 10. Upper handle |
| 4. Chute deflector trigger | 11. Power control bar |
| 5. Discharge chute handle | 12. Cord |
| 6. Cord guide | 13. Handle knobs |
| 7. Chute control rod | 14. Discharge chute |

NOTICE! This machine is intended for outdoor, residential use only. Do not use it indoors or for commercial or industrial purposes.

Connecting to a Power Source

To reduce the risk of electric shock, this machine has a polarized plug (i.e., one blade is wider than the other). Use only a polarized plug, UL-listed (CSA certified in Canada) extension cord recommended for outdoor use. A polarized plug will fit in a polarized cord only one way. If the plug does not fit fully in the cord, reverse the cord. If it still does not fit, purchase a polarized extension cord. If you have a polarized extension cord and the extension cord plug does not fit fully into the wall receptacle, reverse the plug. If it still does not fit, contact a qualified electrician to install the proper outlet. Do not change the machine or extension cord plug in any way.

⚠ DANGER

Contact with water while operating the machine could cause electric shock, causing injury or death.

- Don't handle the plug or the machine with wet hands or while standing in water.
- Use only an extension cord recommended for outdoor cold-weather use.

Extension Cord Length	Minimum Wire Gauge (A.W.G.)
100 feet	14
150 feet	12

Note: Do not use an extension cord over 150 feet.

NOTICE! Check the extension cord frequently during use for holes or cracks in the insulation. Do not use a damaged cord. Do not run the cord through standing water or wet grass.

Note: To prevent the extension cord from disconnecting during operation, use the cord lock on the upper handle before you connect it to the machine (Figure 9).

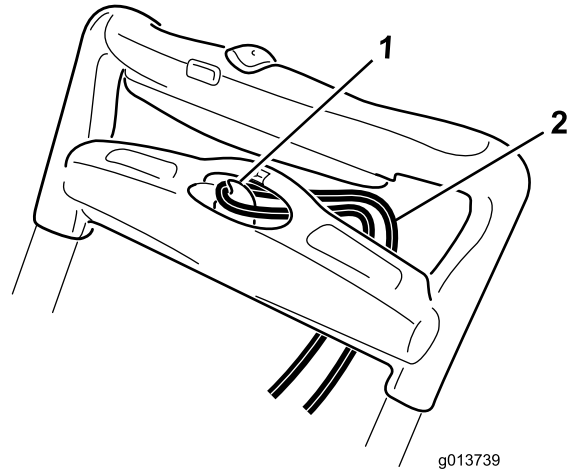

Figure 9

- | | |
|--------------|-------------------|
| 1. Cord lock | 2. Extension cord |
|--------------|-------------------|

⚠ WARNING

A damaged appliance cord can cause a shock or fire.

Thoroughly inspect the appliance cord before using the machine. If the cord is damaged, do not operate the machine. The supply cord or switch of this equipment cannot be replaced, and the equipment shall be scrapped.

Starting and Stopping the Motor

1. To start the motor, insert the key, press and hold the interlock button, and squeeze the power control bar (Figure 10).

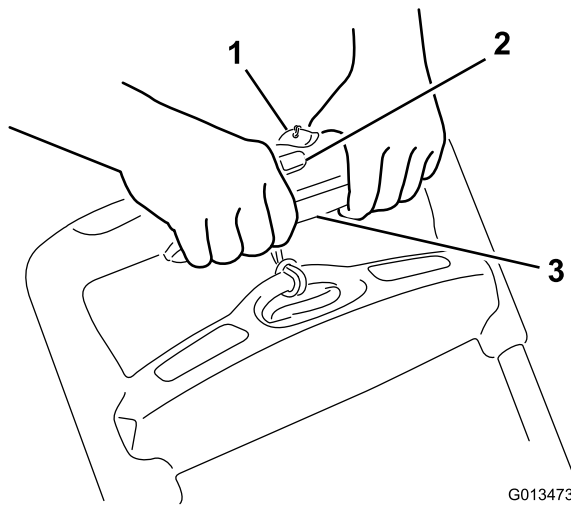

Figure 10

1. Key
2. Interlock button
3. Power control bar

Note: You may release the interlock button after you squeeze and hold the power control bar to the handle.

2. To stop the motor, release the power control bar.

Note: When you stop the machine after you have finished removing the snow, also remove the key and disconnect the extension cord.

Adjusting the Discharge Chute and Chute Deflector

To adjust the discharge chute, move the handle on the chute control rod in the direction that you wish to direct the snow stream (Figure 6 and Figure 7).

To adjust the chute deflector (and therefore the height of the snow stream), squeeze the trigger and raise or lower the chute deflector (Figure 11).

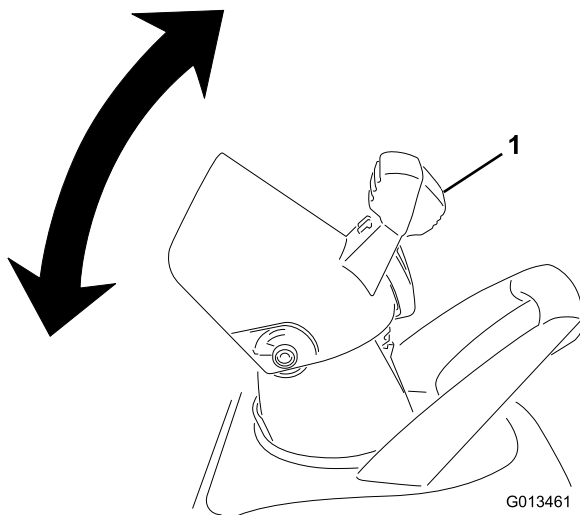

Figure 11

1. Chute deflector trigger

⚠ WARNING

A gap between the discharge chute and the chute deflector may allow the machine to throw snow and objects in the direction of the operator. Thrown objects could cause serious personal injury.

- Do not force the chute deflector too far forward so that a gap appears between the discharge chute and chute deflector.
- Do not adjust the chute deflector with the power control bar engaged. Release the power control bar before adjusting the chute deflector.

Operating Tips

⚠ WARNING

If the machine hits an object while in operation, the object could be thrown in operator's or bystander's direction. Thrown objects could cause serious personal injury.

Keep the area to be cleared free of all objects which may be picked up and thrown by the rotor blades.

- Check the condition of the machine before operating it to ensure that the rotor turns freely.
- Always keep children and pets away from the area of operation.
- Keep the area to be cleared free of stones, toys, or other objects which the rotor blades can throw. Such items could be covered by snowfall and go unnoticed. If the machine strikes an object during operation, stop the machine, unplug the extension cord, remove the obstruction, and check the machine for damage.
- Begin removing snow near the electrical outlet and work outward. Blow back and forth, not away from and toward the outlet.
- When turning at the end of a swath, step over the cord and turn the machine.
- Always overlap each swath and discharge the snow downwind when possible.

⚠ WARNING

When using the discharge chute handle, never direct the snow discharge chute at the operator or bystanders. The machine can throw objects and cause serious personal injury.

When using the discharge chute handle, always turn the discharge chute in the opposite direction from where you or bystanders are standing.

- Keep the extension cord clear of obstructions, sharp objects, and all moving parts. Do not pull sharply on cord or abuse it in any manner. Inspect the extension cord frequently for damage that may result in an electric shock. If the extension cord is damaged, replace it.
- In cold and snowy weather conditions, some controls and moving parts may freeze. Therefore, if any control becomes difficult to operate, stop the motor, disconnect the extension cord, and check for frozen parts. Do not use excessive force when trying to operate frozen controls. Bring the machine indoors to thaw frozen controls before operating it.
- When operating the machine, keep the wheels 1 inch (2.5 cm) off the pavement by tipping the machine forward. This helps prevent the snow from building up on the wheels.
- After clearing the snow, let the motor run for a few minutes so that moving parts do not freeze. Then shut off the motor, wait for all moving parts to stop, and wipe the ice and snow off the machine. Rotate the chute crank several times to remove any snow.

Maintenance

NOTICE! All electrical repairs should be performed by an Authorized Service Dealer only.

Note: Determine the left and right sides of the machine from the normal operating position.

⚠ WARNING

If the extension cord is plugged into the machine, someone could accidentally operate the machine while you are performing maintenance on it, causing serious personal injury.

Remove the key and disconnect the extension cord before you perform any maintenance on the machine.

Lubricating the Machine

You do not need to lubricate the machine; all the bearings have been lubricated at the factory for the life of the machine.

Replacing the Scraper

The scraper is located at the bottom of the rotor housing as shown in Figure 12.

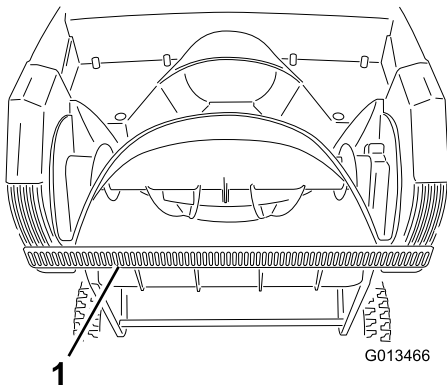

Figure 12

1. Scraper

1. Remove the screw from each side plate that holds the scraper (Figure 13) and 2 screws from under the machine (Figure 14) that secure the scraper to the machine.

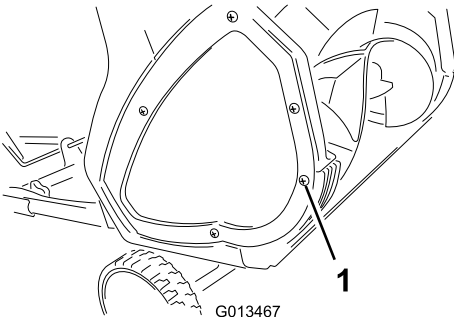
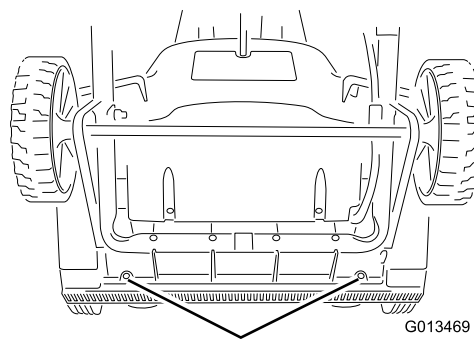

Figure 13

1. Screw (2)



1
Figure 14

1. Screws
2. Remove and discard the old scraper.
3. Install the new scraper, and fasten it securely with the 4 screws that you previously removed.

Replacing the Rotor

1. Remove the screws that secure the right side plate to the machine frame (Figure 15).

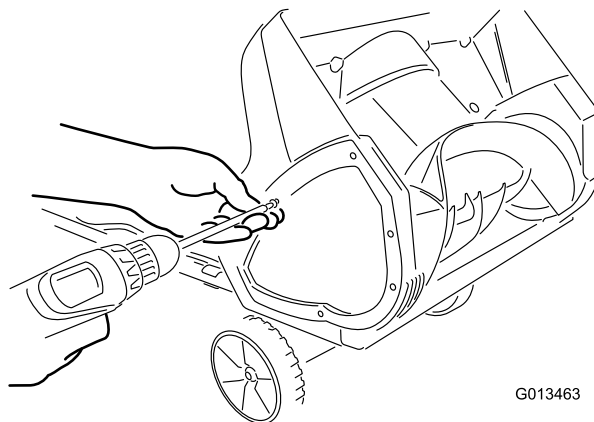
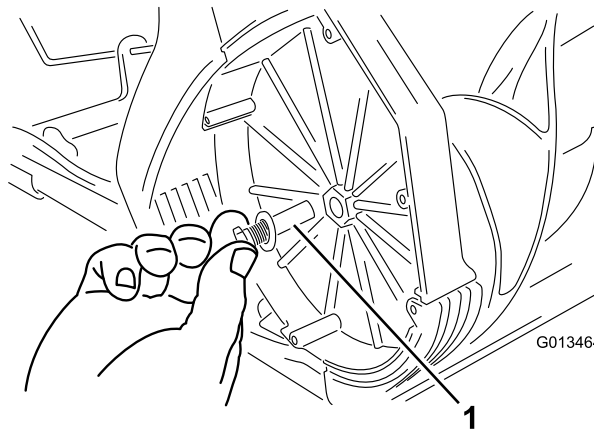

Figure 15

2. Remove the rotor pin (Figure 16).



1
Figure 16

1. Rotor pin
3. Remove the old rotor.

4. Install the new rotor by inserting the end of the rotor onto the fitted end in the housing and rotating the rotor until it snaps into place (Figure 17).

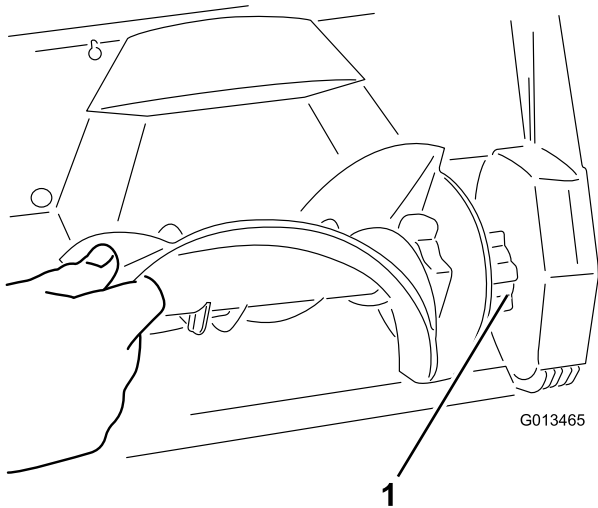

Figure 17

1. Fitted end of the rotor

Note: Ensure that the nut that secures the rotor pin remains inside the recessed hole in the right inside wall of the housing.

Note: The housing will flex when you install the rotor.

5. Tighten the bolt on the side of the housing.
6. Install the right side plate with the screws that you removed in step 1.

Service

Toro has designed this machine to give you years of trouble-free use. Should it need service, bring the machine to an Authorized Toro Service Dealer, who is specially trained to repair Toro products and will ensure that your Toro stays “all” Toro.

Double-insulated Appliances

In a double-insulated appliance, two systems of insulation are provided instead of grounding. No grounding means is provided on a double-insulated appliance, nor should a means for grounding be added to the appliance. Servicing a double-insulated appliance requires extreme care and knowledge of the system, and should be done only by the qualified service personnel at an Authorized Toro Service Dealer. Replacement parts for a double-insulated appliance must be identical to the parts they replace. A double-insulated appliance is marked with the words “Double Insulation” or “Double Insulated.” The symbol (square within a square)  may also be marked on the appliance.

Product Information

A model and serial number decal is located on the housing. Always refer to specific numbers on the decal in correspondence or when you need replacement parts.

Storage

1. Run the machine for a few minutes and wipe away any melted snow on the machine.
2. Remove the key and disconnect the extension cord from the machine.
3. Examine the extension cord thoroughly for signs of wear or damage. Replace it if it is worn or damaged.
4. Examine the machine thoroughly for worn, loose, or damaged parts. To repair or replace parts, contact an Authorized Service Dealer for assistance.
5. Store the extension cord with the machine.
6. Store the machine in a clean, dry place.

The Toro Promise - Electric Snowthrowers and Brooms

A Two-Year Full Warranty for Residential Use for the United States and Canada

The Toro Company and its affiliate, Toro Warranty Company, pursuant to an agreement between them, jointly warrant this product for two years against defects in material or workmanship when used for normal residential purposes.*

If you think your Toro Product contains a defect in materials or workmanship, follow this procedure:

- If you have questions or problems, or before returning this product, call toll free: 1-800-808-2963 (US) or 1-800-808-3072 (Canada).
- To receive a replacement or repair, at our option, return the complete unit to the seller. United States and Canada customers may return their product, with proof of purchase, to any Authorized Service Dealer. United States customers may also return their product, with proof of purchase, postage prepaid, to the Toro Service Center, 21350 Cedar Avenue S., Lakeville, MN 55044-9090.

This warranty covers product defects only. **Neither The Toro Company nor Toro Warranty Company is liable for indirect, incidental or consequential damages in connection with the use of the Toro Products covered by this warranty, including any cost or expense of providing substitute equipment or service during reasonable periods of malfunction or non-use pending completion of repairs under this warranty. Some states do not allow exclusions of incidental or consequential damages, so the above exclusions may not apply to you.** This warranty gives you specific legal rights, and you may also have other rights which vary from state to state.

Countries Other than the United States and Canada

Customers who have purchased Toro products exported from the United States or Canada should contact their Toro Distributor (Dealer) to obtain guarantee policies for your country, province, or state. If for any reason you are dissatisfied with your Distributor's service or have difficulty obtaining guarantee information, contact the Toro importer. If all other remedies fail, you may contact us at Toro Warranty Company.

* Residential use means use of the product on the same lot as your home.

Part Number 374-0262 Rev. C

Notes:



Count on it.