



Count on it.

Parts Catalog

GrandStand® Mower

With 122cm TURBO FORCE® Cutting Unit

Model No. 74568TE—Serial No. 310000001 and Up

Ordering Replacement Parts

To order replacement parts, please supply the part number, the quantity, and the description of each part desired.

Understanding Reference Numbers

Each identified part in an illustration has a reference number. The reference number for a part also appears in the parts list, along with other information about the part.

This catalog uses two special reference number formats, one to indicate parts in a service assembly and another to indicate the quantity of a given part in an illustration.

Service Assembly Reference Numbers

Parts in service assemblies have reference numbers in the form a:b. The a represents the reference number of the entire service assembly and the b represents a sequential number unique to each part within the service assembly.

For example, a wheel assembly might be identified by reference number 6, the tire by 6:1, the valve by 6:2, and the wheel by 6:3. When you order the assembly identified by reference number 6, you receive all parts identified by reference numbers 6:1, 6:2, and 6:3. However, you may also order any part individually. Reference numbers of this type appear in illustration and in parts lists.

Reference Numbers Indicating Quantity

In an illustration, if a reference number indicates more than one part, the reference number has the form nX y. The n represents the quantity of the part, the X is the multiplication symbol, and the y represents the reference number.

For example, in an illustration, the reference number 2X 37 means that two of the parts identified by reference number 37 are indicated.

List of Abbreviations

AR: as required

ASM: assembly

BBC: blade brake control

BHTF: button head thread forming

CARR: carriage

CCW: counter clockwise

CW: clockwise

DEG: degrees

ECM: electronic control module

EXT: external

FH: flat head

GA: gauge

HD: heavy-duty

HF: hex flange

HH: hex head

HHF: hex head flange

HHFTF: hex head flange thread forming

HJ: hex jam

HLH: hex lag head

HOC: height-of-cut

HSBH: hex socket button head

HSFH: hex socket flat head

HSH: hex socket head

HWH: hex washer head

HWHTF: hex washer head thread forming

HYD: hydraulic

LH: left hand

LP: Liquid Propane

NI: nylon insert

NPTF: national pipe thread fine

PFH: phillips flat head

PPH: phillips pan head

PPHTF: phillips pan head thread forming

PRH: phillips round head

PTH: phillips truss head

PTO: power-take-off

RH: right hand

ROPS: roll-over protection system

RRB: rear roller brush

SFH: slotted fillister head

SHH: slotted hex head

SHWH: slotted hex washer head

SPH: slotted pan head

SQH: square head

SRH: slotted round head

STD: standard

TAP: self tapping

TTH: torx truss head

Contents

Frame Assembly.....	4
Wheel and Bearing Assembly No. 112-3810.....	6
Park Brake Assembly.....	7
Decklift Assembly.....	8
Platform Assembly.....	10
Cushion Assembly No. 117-9770.....	11
Platform Assembly No. 117-9640.....	12
Ground Drive Assembly.....	13
Hydraulic Motor Assembly No. 114-0549.....	15
Hydraulic Pump Assembly No. 117-3597.....	16
Pump Idler Assembly.....	17
Control Assembly.....	18
Engine Assembly.....	20
Fuel Tank Assembly.....	21
Electrical Assembly.....	22
Deck Assembly.....	23
Deck Assembly No. 119-7262.....	24
Spring Idler Assembly No. 117-0445.....	25
Idler Adjust Assembly No. 117-0446.....	26
Spindle Assembly No. 117-6158.....	27
Deflector Assembly No. 114-1910.....	28
Attachments and Accessories.....	29

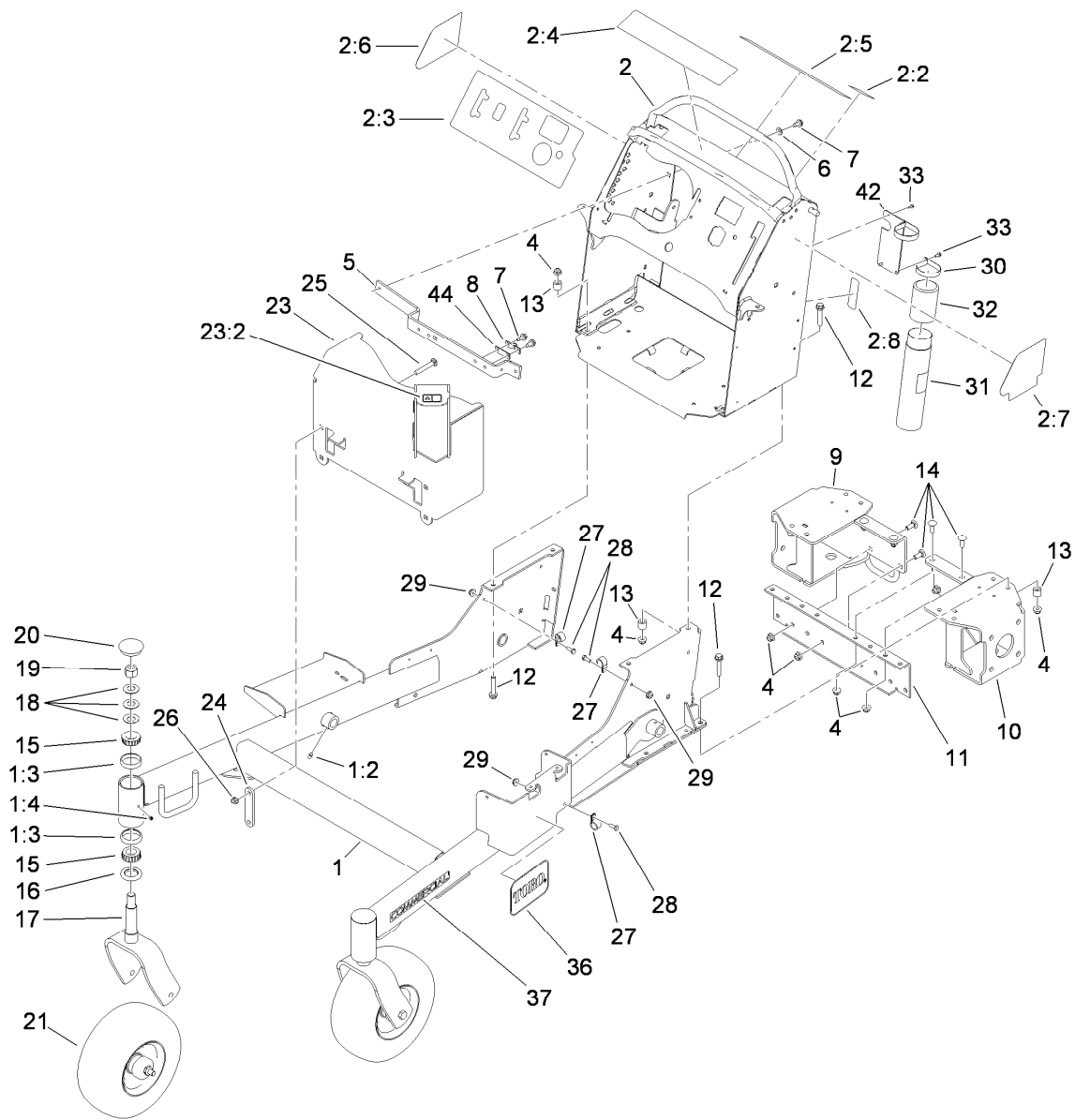

Frame Assembly

Ref.	Part Number	Qty.	Description	Ref.	Part Number	Qty.	Description
1	117-9690	1	Front Frame ASM	13	98-8895	8	Spacer
1:2	302-5	2	Fitting-Grease	14	3231-22	8	Screw-CARR
1:3	1-543508	4	Cup-Bearing	15	1-543509	4	Bearing-Roller, Tapered
1:4	1-811010	2	Plug	16	1-543511	2	Seal-Grease
2	117-9716	1	Control Tower ASM	17	103-8618-01	2	Fork-Caster
2:2	119-8663	1	Decal-Stability, Ce	18	1-633508	6	Washer-Bellville
2:3	119-7245	1	Decal-Panel, Control	19	3296-51	2	Nut-Lock, NI
2:4	117-0454	1	Decal-Opc	20	103-4882	2	Cap-Grease
2:5	117-3626	1	Decal-Warning	21	112-3810	2	Wheel And Bearing ASM
2:6	119-7247	1	Decal-HOC	23	119-0230	1	Muffer Guard ASM
2:7	119-7285	1	Decal-Service Aid, Ce	23:2	106-5517	1	Decal-Surface, Hot
2:8	116-3267	1	Decal-Fuse	24	117-0427-01	2	Bracket-Mounting, Guard
4	104-8301	16	Nut-Flange, NI	25	3231-31	4	Screw-CARR
5	114-1921-03	1	Bar-Cable	26	32128-21	4	Nut-HF
6	3256-23	2	Washer-Flat	27	2412-87	3	Clamp-Cable
7	32144-70	6	Screw-HWHTF	28	321-4	3	Screw-HH
8	93-2279	2	Clamp-Cable	29	104-7201	3	Nut-HF
9	119-7222-01	1	RH Motor Mount ASM	30	2412-120	2	R-Clamp
10	119-7220-01	1	LH Motor Mount ASM	31	104-7050	1	Tube-Manual
11	119-7224-01	1	Mount-Motor, Center	32	104-7048	1	Cap-Housing
12	108-3742	8	Screw-HHF	33	32144-1	4	Screw-Taptite

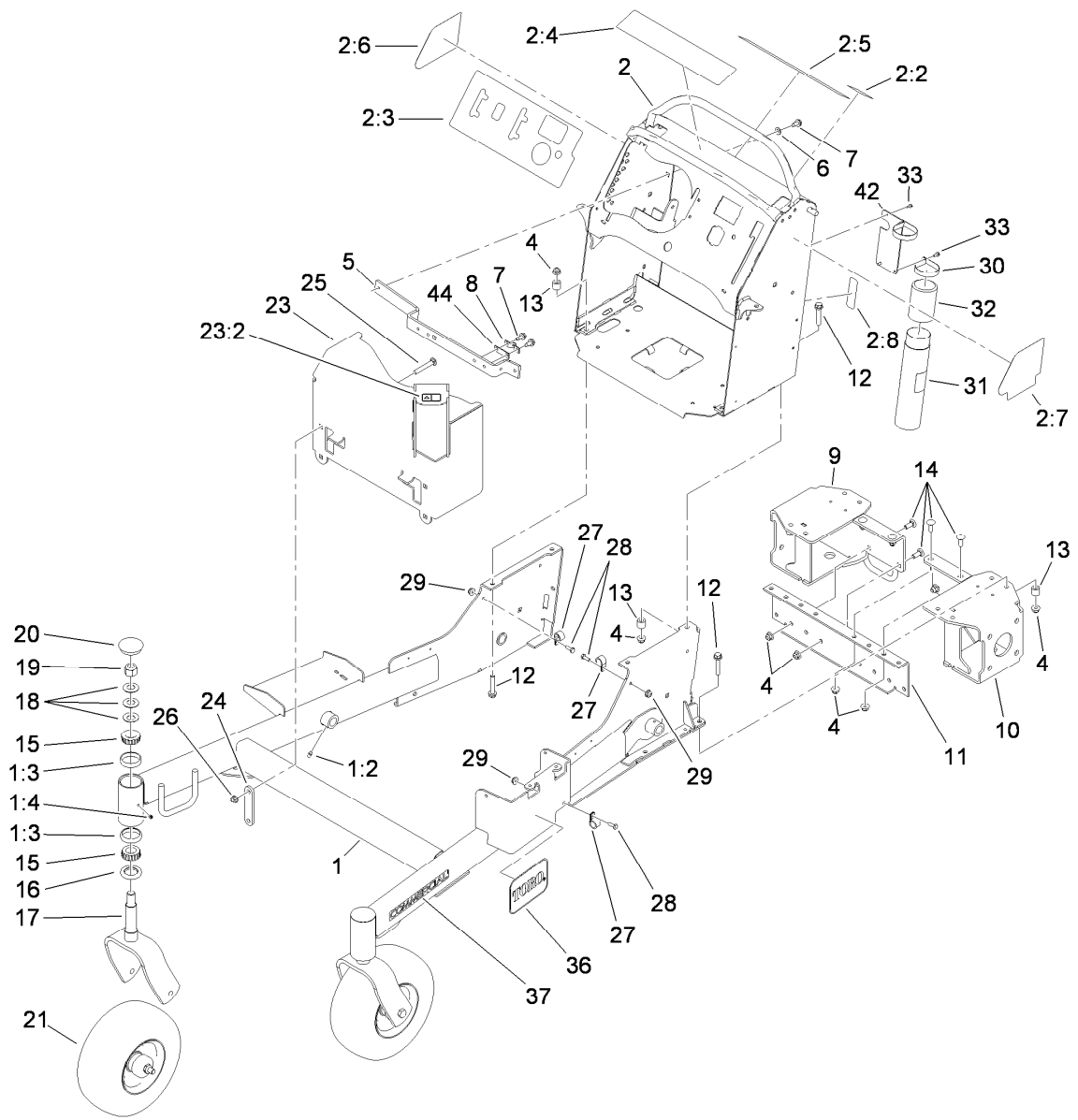

Frame Assembly (continued)

<i>Ref.</i>	<i>Part Number</i>	<i>Qty.</i>	<i>Description</i>	<i>Ref.</i>	<i>Part Number</i>	<i>Qty.</i>	<i>Description</i>
36	68-3640	1	Decal	42	117-9745-01	1	Plate-Manual
37	117-3591	2	Decal-Commercial	44	119-2445	2	Shim-Cable

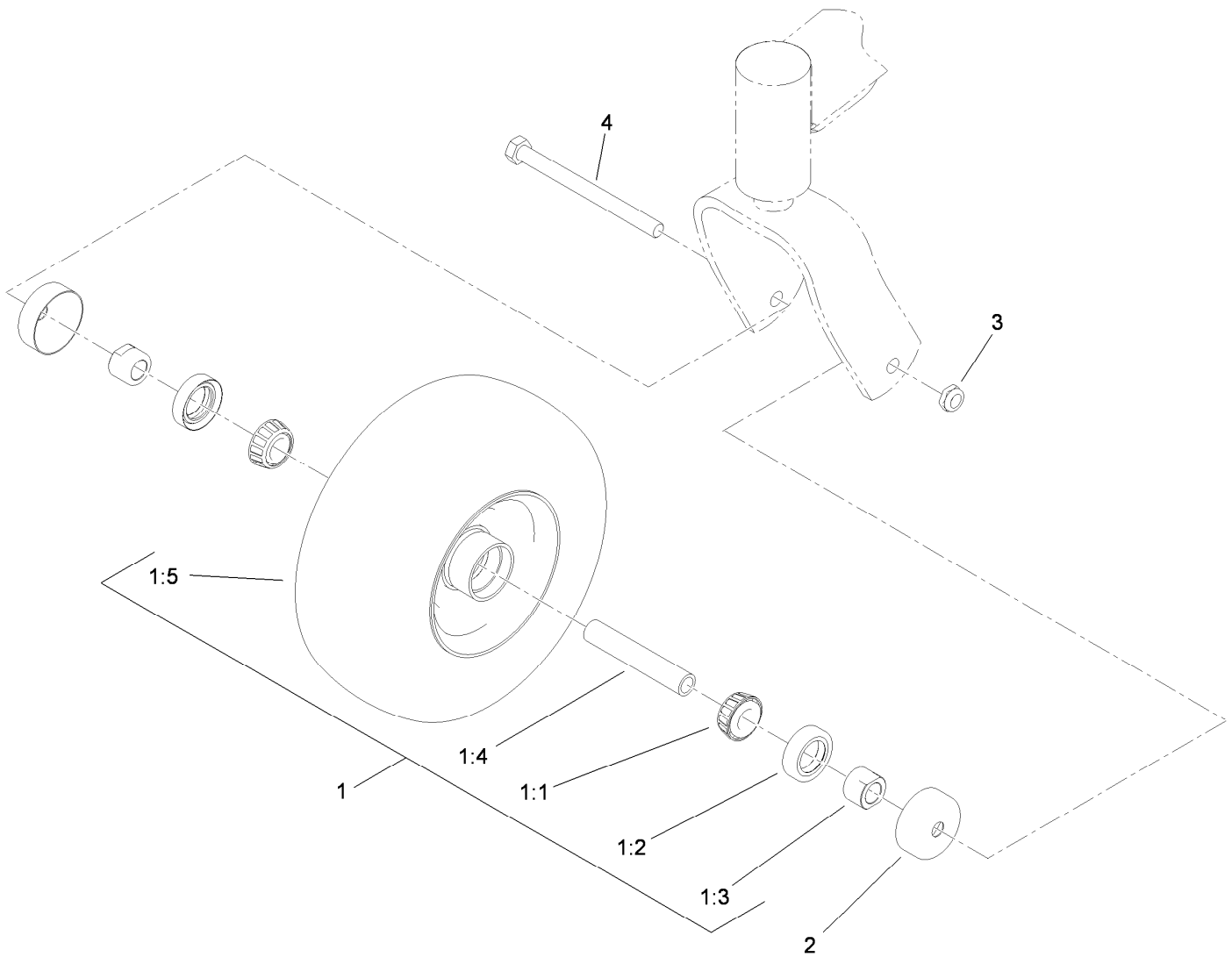

Wheel and Bearing Assembly No. 112-3810

Ref.	Part Number	Qty.	Description
1		1	Wheel And Bearing ASM ●
1:1	1-633585	2	Bearing-Cone, Taper
1:2	103-0063	2	Seal-Caster
1:3	103-3051	2	Spacer-Nut
1:4	103-3157	1	Axle-Caster
1:5	110-9965	1	Wheel And Tire ASM
2	103-2768	2	Guard-Seal
3	3296-45	1	Nut-Lock, NI
4	325-20	1	Screw-HH

● Not serviced separately

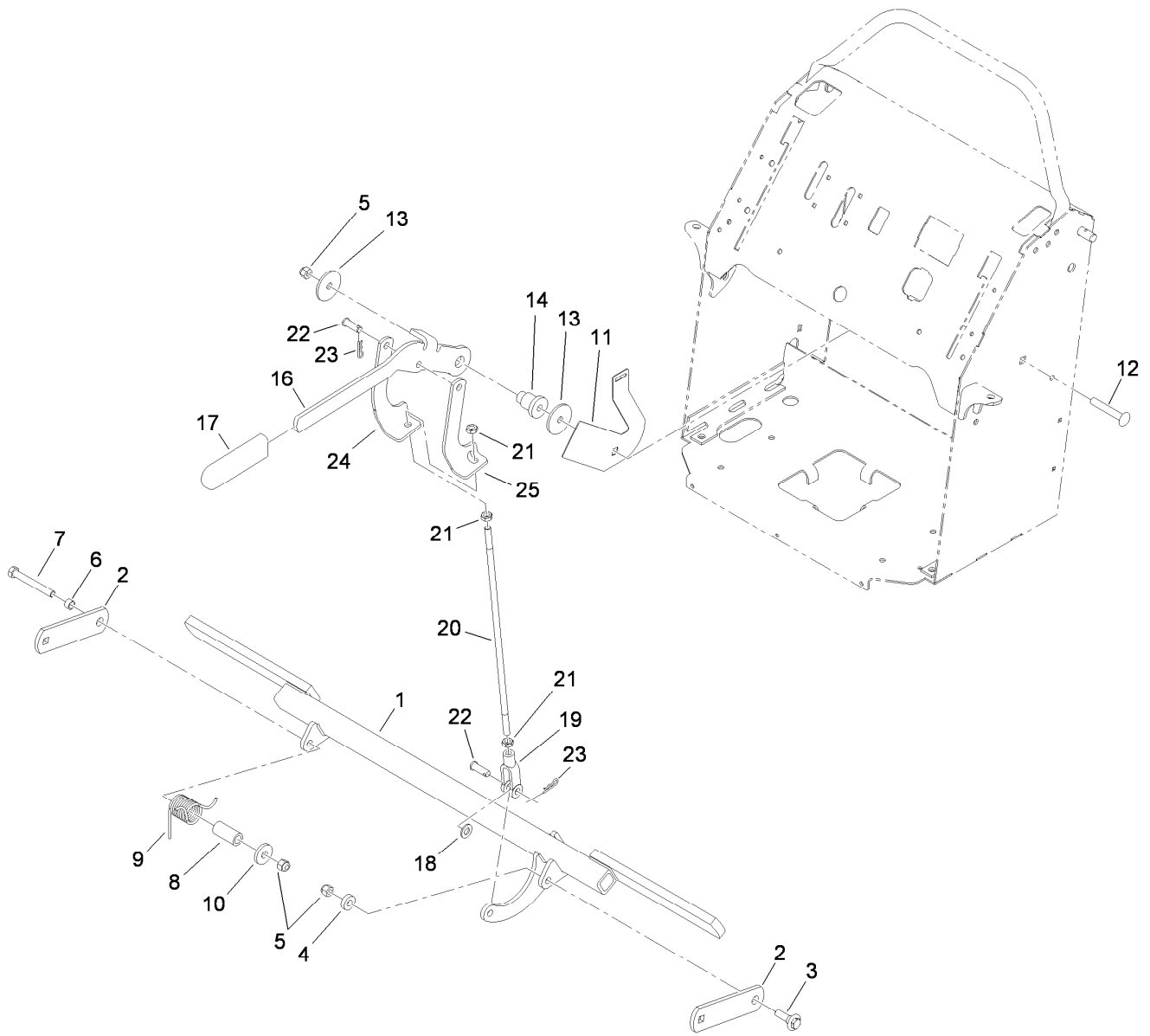

Park Brake Assembly

Ref.	Part Number	Qty.	Description	Ref.	Part Number	Qty.	Description
1	117-2660-03	1	Brake ASM	13	63-7400	2	Washer-Rebound
2	114-5186-01	2	Support-Brake	14	106-3214	1	Mount-Pulley
3	614672	1	Bolt-Shoulder	16	117-5759-03	1	Lever-Brake
4	5-0652	1	Spacer	17	1-633268	1	Grip-Lever
5	3296-39	3	Nut-Lock, NI	18	3256-24	1	Washer-Flat
6	117-9684	1	Spacer	19	1-633131	1	Yoke-Linkage, Brake
7	323-14	1	Screw-HH	20	119-7244	1	Rod-Brake
8	117-9683	1	Spacer	21	3220-3	3	Nut-HJ
9	117-9682	1	Spring-Torsion	22	283-2	2	Pin-Clevis
10	1-373034	1	Washer	23	3290-307	2	Pin-Hair
11	117-0452-03	1	Plate-Switch, Brake	24	119-7242-03	1	Arm-Brake, Bottom
12	3231-44	1	Screw-CARR	25	119-7243-03	1	Arm-Brake, Top

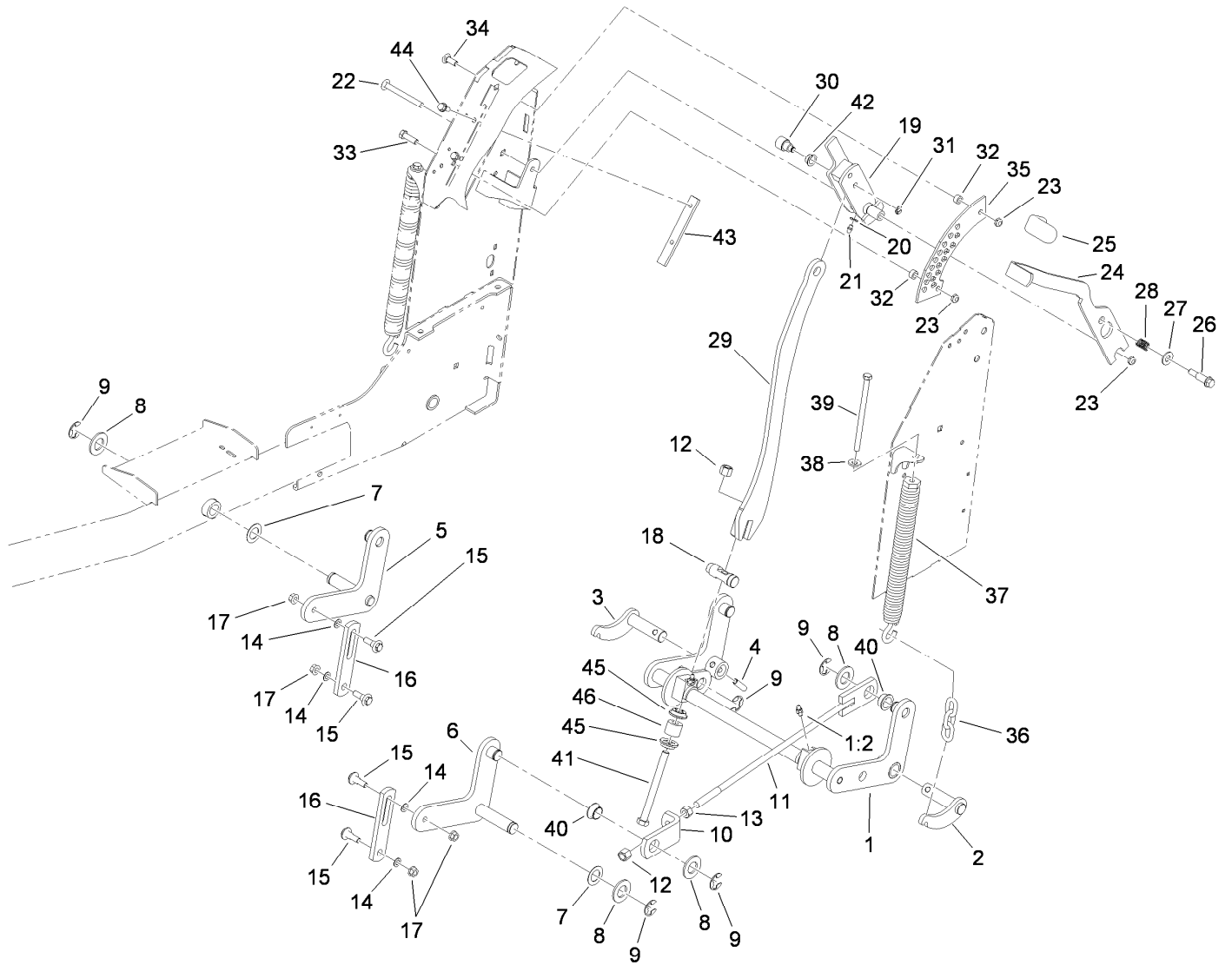

Decklift Assembly

Ref.	Part Number	Qty.	Description	Ref.	Part Number	Qty.	Description
1	116-3103	1	Rear Crossshaft ASM	21	302-5	1	Fitting-Grease
1:2	302-11	2	Fitting-Lube, 45 DEG	22	3231-24	1	Screw-CARR
2	116-3104-01	1	LH Pivot Shaft ASM	23	3296-59	3	Nut-Lock, NI
3	116-3105-01	1	RH Pivot Shaft ASM	24	114-1878-03	1	Lever-HOC
4	116-3107	2	Pin-Spiral	25	1-633268	1	Grip-Lever
5	117-0489-01	1	RH Lift ASM	26	66-0561	1	Screw-Shoulder
6	117-0488-01	1	LH Lift ASM	27	3256-26	1	Washer-Flat
7	110-6767	2	Washer-Thrust	28	65-9940	1	Spring
8	3256-29	6	Washer-Flat	29	116-2939	1	Bar-Lift
9	32151-103	7	Ring-Retaining, EXT	30	116-3048	1	Hub-Pivot
10	116-2901	2	Bracket-Lift Rod	31	32151-47	1	Ring-Retaining
11	116-2902	2	Lift Rod ASM	32	111044	2	Spacer
12	3296-23	3	Nut-Lock, NI	33	323-7	1	Screw-HH
13	3217-9	2	Nut-HH	34	3231-22	1	Screw-CARR
14	40-1940	4	Washer	35	114-5307	1	Bracket-HOC
15	109-9840	4	Screw-Shoulder, HHF	36	103-9859	2	Chain-Decklift, Front
16	117-0519	2	Link-Lift	37	116-0886	2	Extension Spring ASM
17	32128-21	4	Nut-HF	38	98-5975	2	Washer-Belleville
18	114-5274	1	Pin-HOC	39	323-58	2	Bolt-TAP, HH
19	114-3512	1	HOC Handle ASM	40	116-2909	4	Bearing-Flange
20	3256-22	1	Washer-Flat	41	325-22	1	Screw-HH

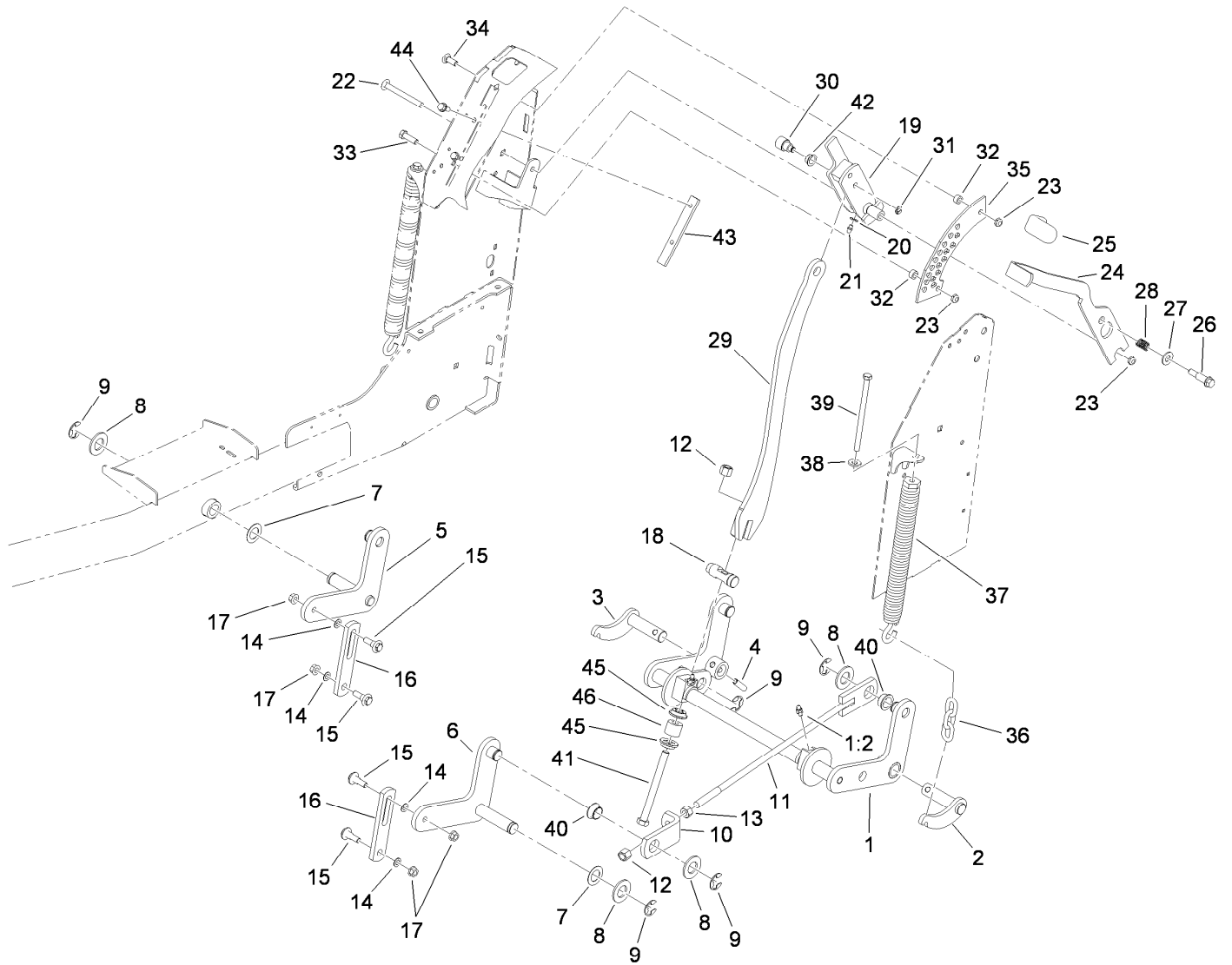

Decklift Assembly (continued)

<i>Ref.</i>	<i>Part Number</i>	<i>Qty.</i>	<i>Description</i>	<i>Ref.</i>	<i>Part Number</i>	<i>Qty.</i>	<i>Description</i>
42	116-3047	1	Bearing-Flange	45	116-3240	2	Seat-Spring
43	116-3124	1	Skid-Handle, Lift	46	116-3241	1	Spring-Urethane
44	32144-11	2	Screw-HWHTF				

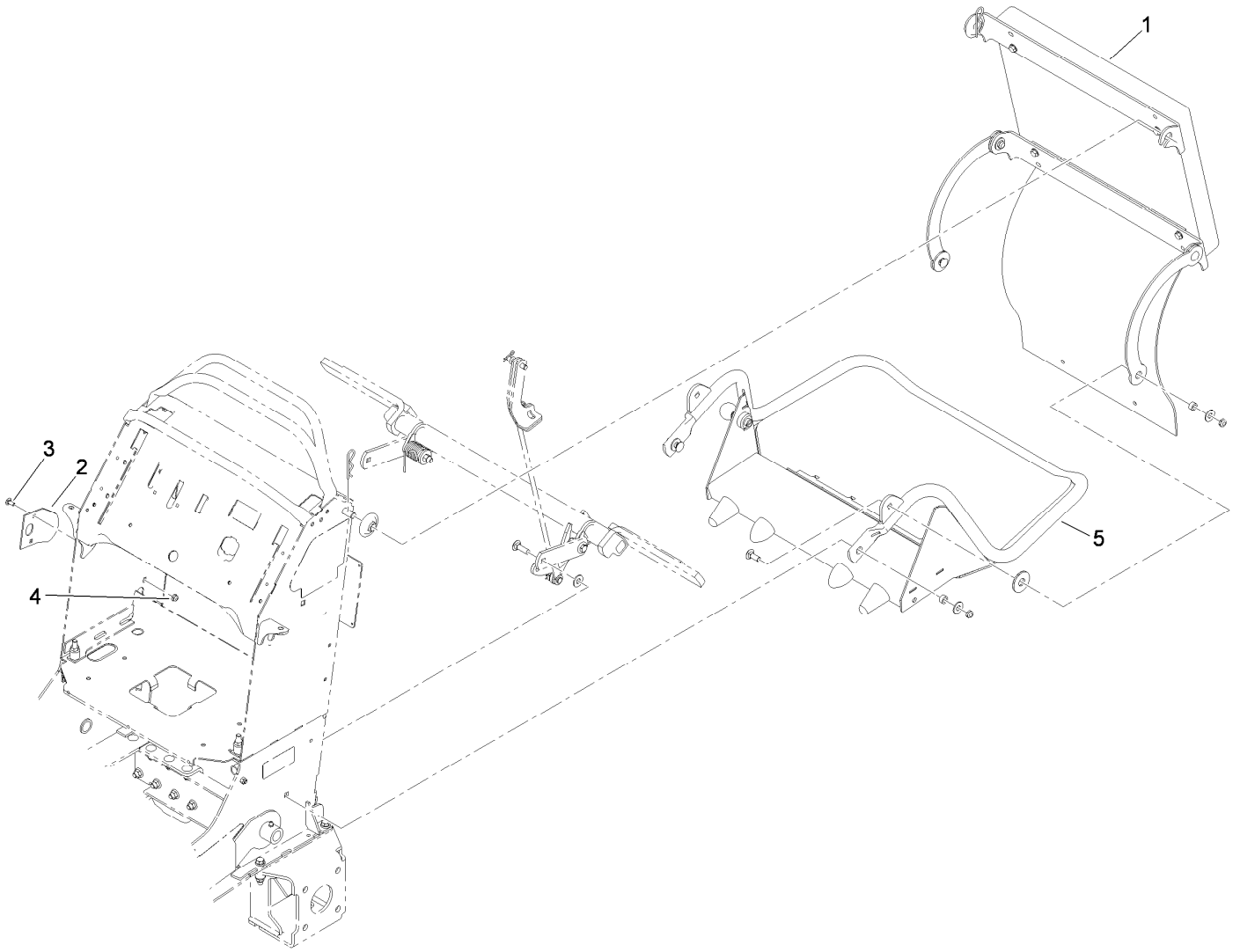

Platform Assembly

<i>Ref.</i>	<i>Part Number</i>	<i>Qty.</i>	<i>Description</i>
1	117-9770	1	Cushion ASM
2	114-1924	1	Plate-Strike
3	3229-11	2	Screw-CARR
4	104-7201	2	Nut-HF
5	117-9640	1	Platform ASM

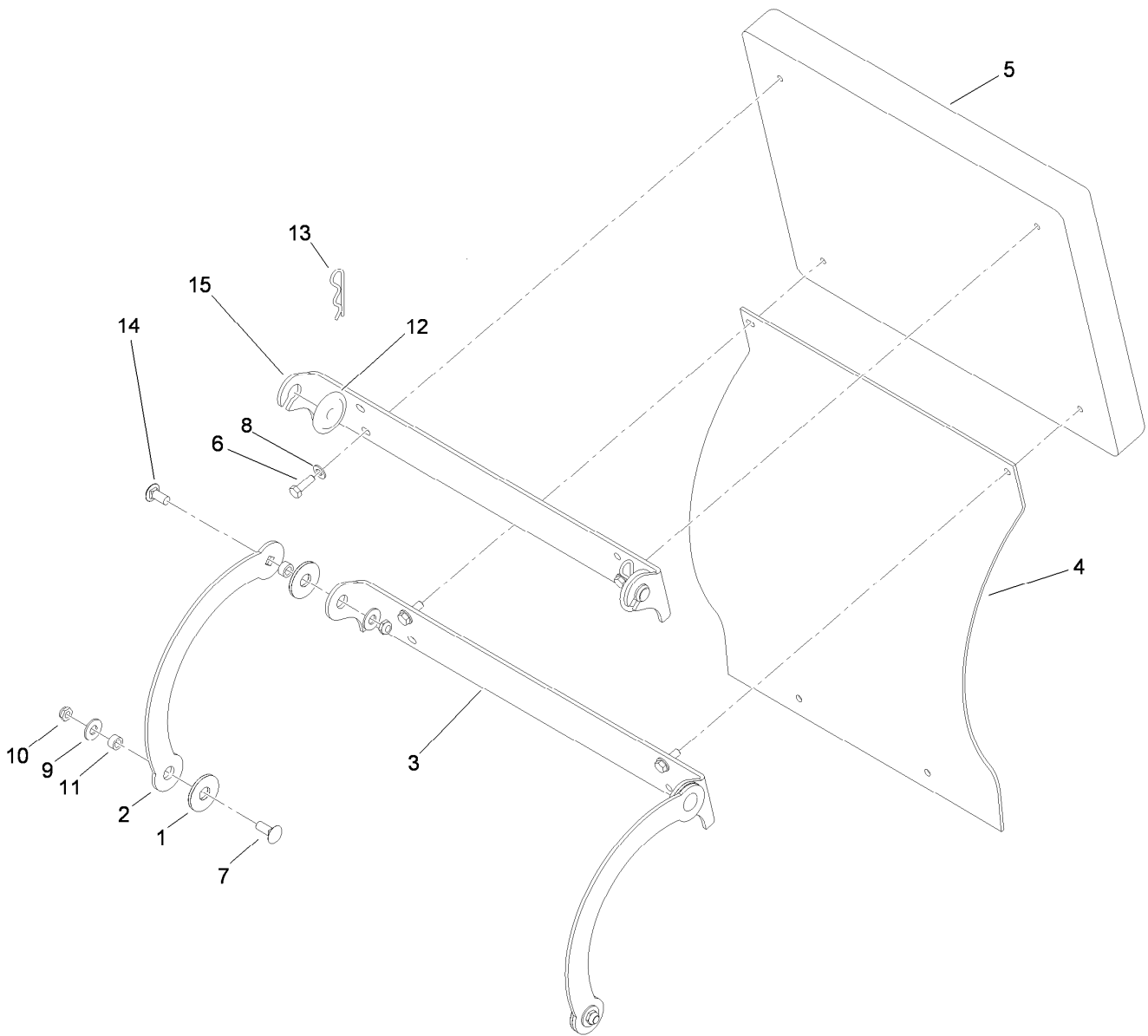

Cushion Assembly No. 117-9770

Ref.	Part Number	Qty.	Description
1	114-0463	4	Washer-Friction, Composite
2	114-1915-01	2	Link-Pad
3	116-2061-03	1	Hinge-Pad
4	114-1919	1	Shield-Rear
5	117-9739	1	Pad-Cushion
6	322-5	4	Screw-HH
7	3231-2	2	Screw-CARR
8	3256-23	4	Washer-Flat
9	3256-4	8	Washer-Flat
10	3296-59	4	Nut-Lock, NI
11	111044	4	Spacer
12	116-2886	2	Slide-Bushing
13	3290-355	2	Pin-Hair
14	3231-27	2	Screw-CARR
15	116-2757-03	1	Hinge-Pad

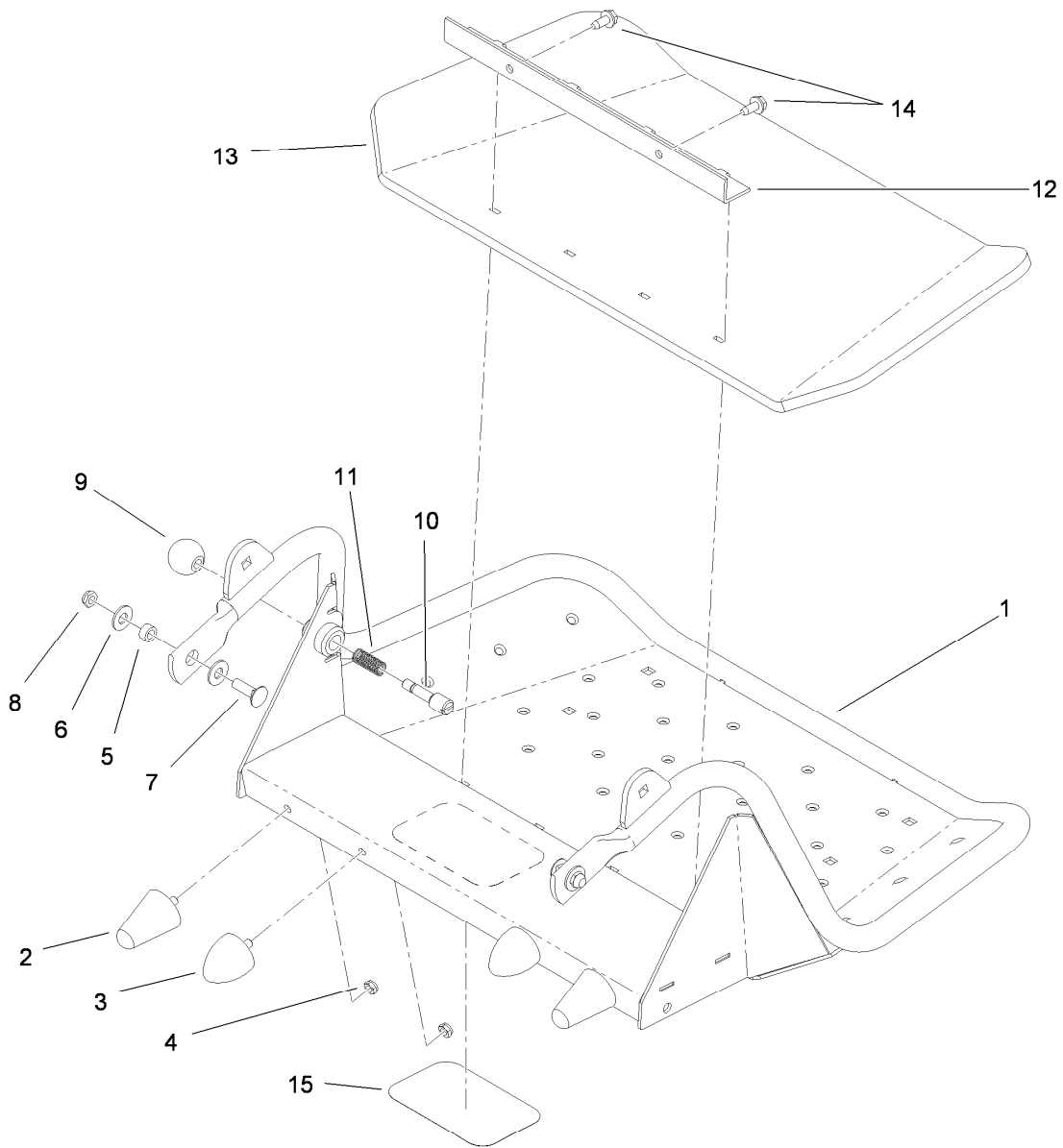

Platform Assembly No. 117-9640

Ref.	Part Number	Qty.	Description
1	117-9641-01	1	Platform ASM
2	114-1925	2	Bumper-Rubber
3	114-1926	2	Bumper-Rubber
4	3296-47	4	Nut-Lock, NI
5	111044	2	Spacer
6	3256-4	4	Washer-Flat
7	3231-25	2	Screw-CARR
8	3296-59	2	Nut-Lock, NI
9	1-603175	1	Knob-Ball
10	114-5288	1	Pin-Latch
11	114-5348	1	Spring
12	114-1920-03	1	Clamp-Shield
13	114-5349	1	Mat-Foot
14	32144-70	2	Screw-HWHTF
15	68-3640	1	Decal

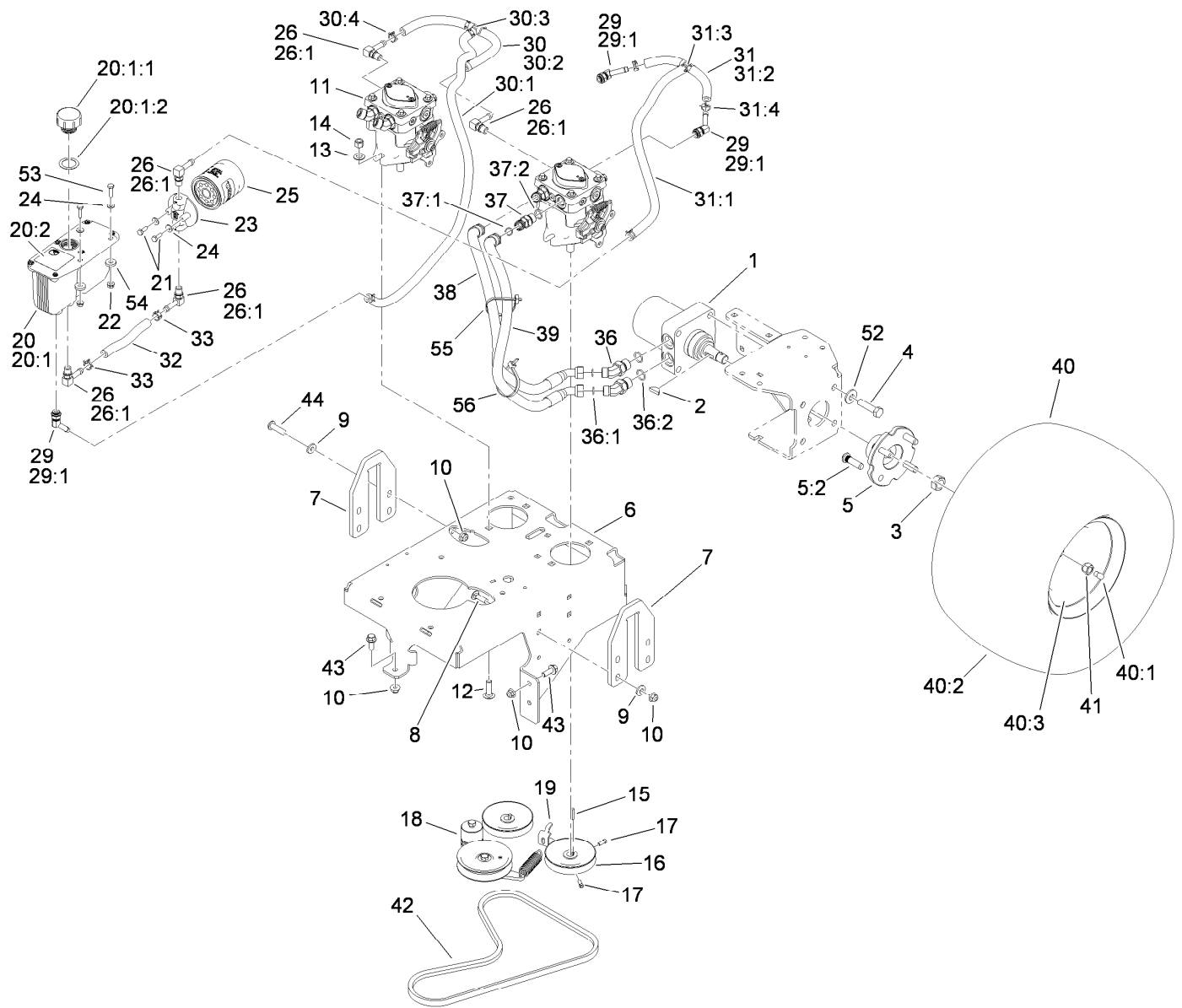

Ground Drive Assembly

Ref.	Part Number	Qty.	Description	Ref.	Part Number	Qty.	Description
1	114-0549	2	HYD Motor ASM	19	117-0447-01	1	Bracket-Anchor, Spring
2	3257-8	2	Key-Woodruff	20	107-8433	1	HYD Reservoir ASM
3	85-7310	2	Nut-Motor, Wheel	20:1		1	Reservoir-HYD ●
4	325-8	8	Screw-HH	20:1:1	103-1948	1	Cap-Reservoir, HYD
5	105-0800	2	Wheel Hub ASM	20:1:2	103-1949	1	Gasket-Cap
5:2	10-6830	4	Stud-Type, Drive	20:2	115-4212	1	Decal-Warning
6	116-2660-01	1	Base-Engine	21	321-4	2	Screw-HH
7	119-8662	2	Plate-Lift	22	32128-32	2	Nut-HHF
8	3231-25	7	Screw-CARR	23	104-7836	1	Head-Filter
9	98-5975	8	Washer-Belleville	24	3256-22	4	Washer-Flat
10	104-8301	13	Nut-Flange, NI	25	114-3494	1	Element-Filter, 25 Micron
11	117-3597	2	HYD Pump ASM	26	100-4887	5	Fitting-Barbed, 90 DEG
12	3232-3	4	Screw-CARR	26:1	237-42	1	O-Ring
13	3256-25	4	Washer-Flat	29	103-1807	3	Fitting-Barbed, 45 DEG
14	3296-48	4	Nut-Lock, NI	29:1	237-42	1	O-Ring
15	1-807272	2	Key	30	117-3570	1	Tank Hose ASM
16	105-5648	2	Pulley-Pump	30:1	117-0461	1	Hose-Hydraulic
17	3241-5	4	Screw-Set	30:2	117-0459	2	Hose-Hydraulic
18		1	Pump Idler ASM ●	30:3	1-603721	2	Fitting-Tee, Hose

● Not serviced separately

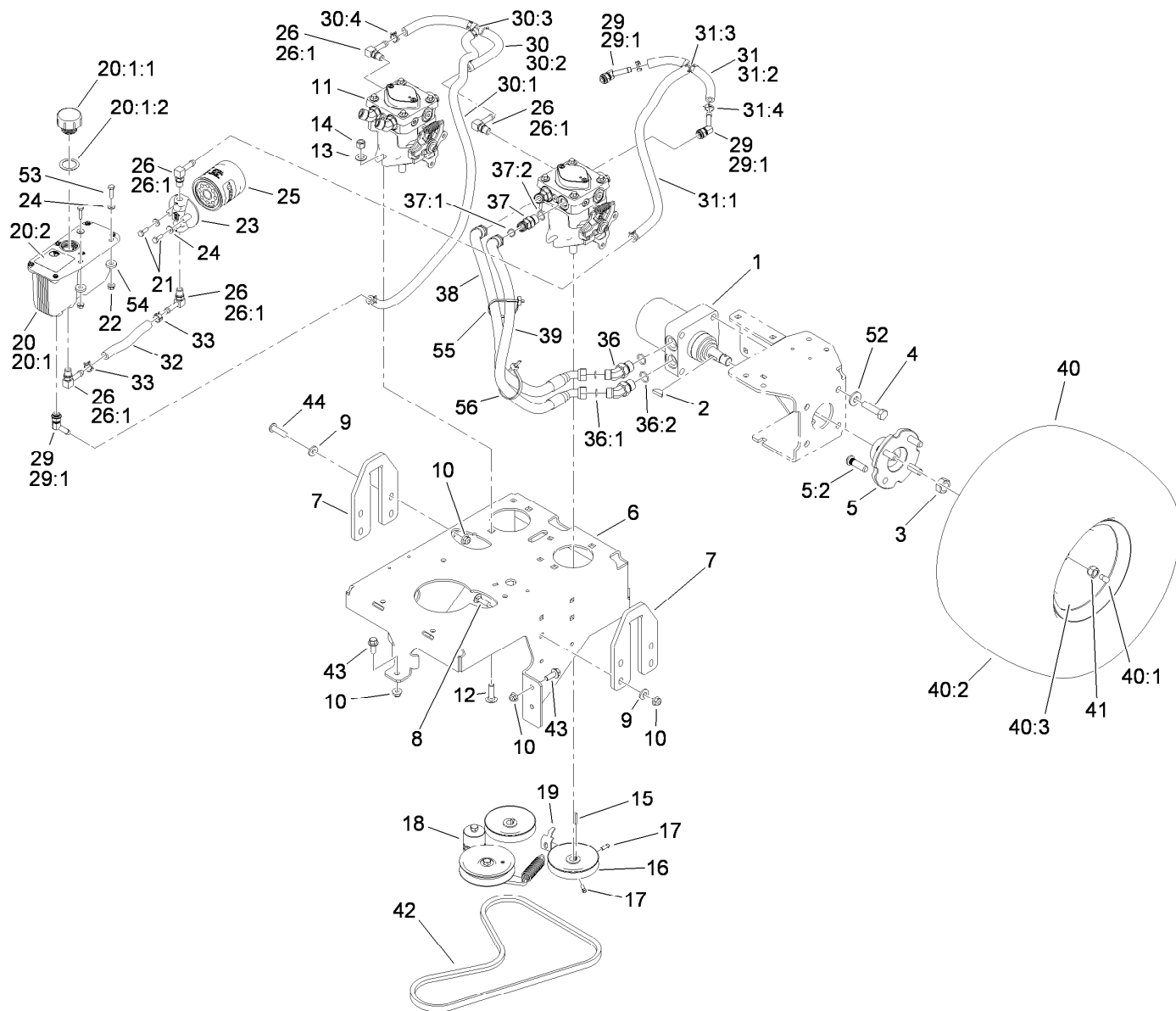

Ground Drive Assembly (continued)

Ref.	Part Number	Qty.	Description	Ref.	Part Number	Qty.	Description
30:4	103-1988	6	Clamp-Hose	39	117-0449	2	HYD Hose ASM
31	117-3569	1	Filter Hose ASM	40	117-0429	2	Wheel ASM
31:1	117-0460	1	Hose-Hydraulic	40:1	232-27	1	Stem-Valve
31:2	117-0458	2	Hose-Hydraulic	40:2	117-0428	1	Tire
31:3	1-603721	2	Fitting-Tee, Hose	40:3	106-8133	1	Rim-8 Inch
31:4	103-1988	6	Clamp-Hose	41	242-50	8	Nut-Lug
32	117-0459	1	Hose-Hydraulic	42	114567	1	Belt-V, Lower PTO
33	103-1988	2	Clamp-Hose	43	3234-42	5	Screw-HHF
36	340-89	4	Fitting-HYD, 45 DEG	44	3274-63	1	Screw-HSBH
36:1	237-30	1	O-Ring	52	1-513435	8	Washer-Spring
36:2	237-80	1	O-Ring	53	321-6	2	Screw-HH
37	340-101	4	Fitting-HYD, 45 DEG	54	104-7658	4	Spacer
37:1	237-30	1	O-Ring	55	1-643115	2	Tie-Plastic
37:2	237-79	1	O-Ring	56	103-2446	2	Tie-Plastic
38	117-0442	2	HYD Hose ASM				

● Not serviced separately

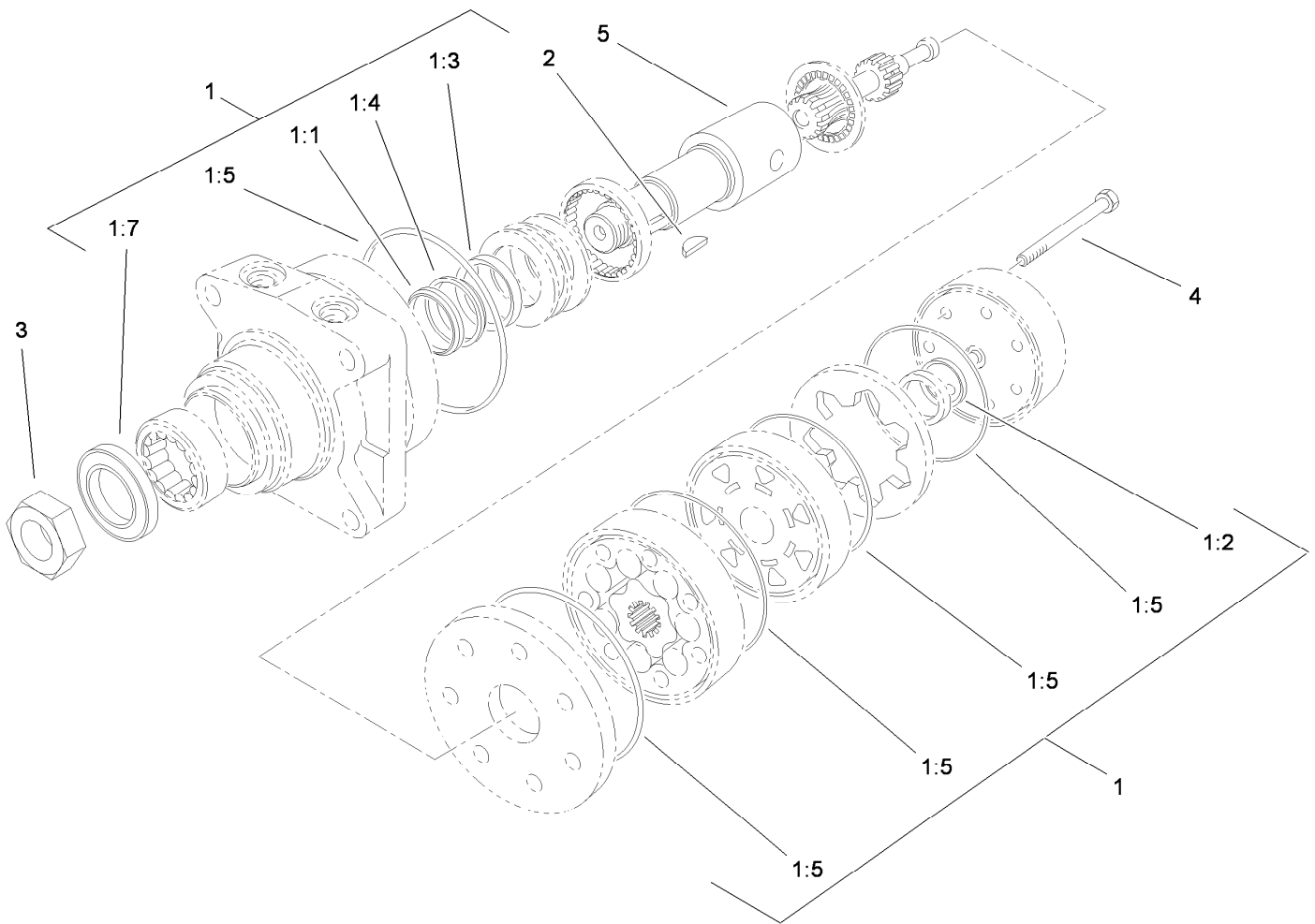

Hydraulic Motor Assembly No. 114-0549

Ref.	Part Number	Qty.	Description
1	1-000119	1	Seal Kit
1:1		1	Ring-Back Up ●
1:2		1	Seal-Commutator ●
1:3		1	Seal-Shaft (Viton) ●
1:4		1	Washer-Back Up, Steel ●
1:5		5	Ring-Seal (Viton) ●
1:7		1	Seal-Dirt And Water ●
2	3257-8	1	Key-Woodruff
3	85-7310	1	Nut-Motor, Wheel
4	106-5549	6	Bolt-Special
5	106-8764	1	Shaft-Coupling

● Not serviced separately

99- Seal Overhaul Kit

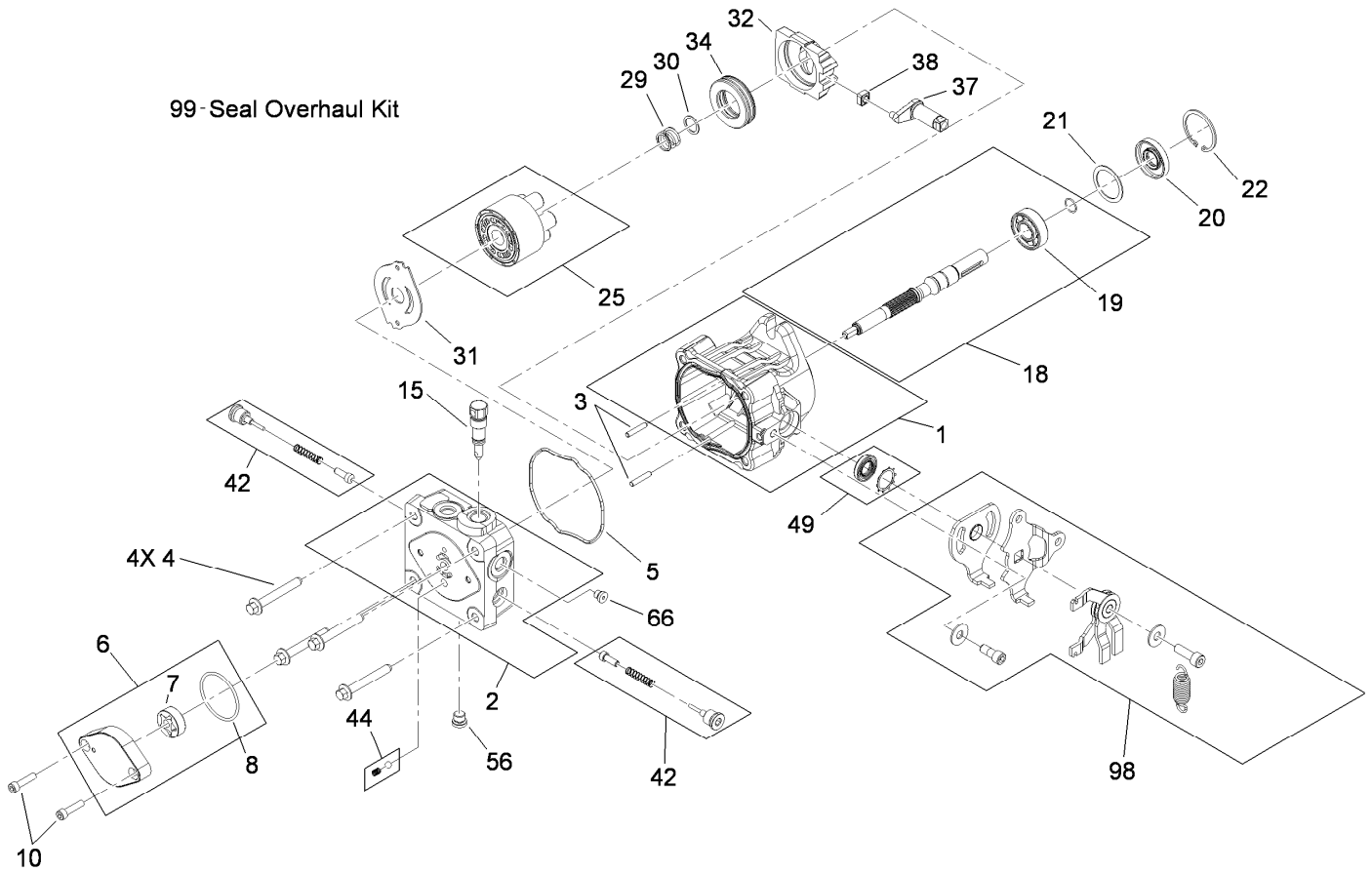

Hydraulic Pump Assembly No. 117-3597

Ref.	Part Number	Qty.	Description	Ref.	Part Number	Qty.	Description
1	115-4464	1	Housing Kit	29	94-1936	1	Spring-Block
2	106-8752	1	End Cap Kit (W/Poppets)	30	94-1937	1	Washer-Thrust, Block
3	106-8753	2	Pin-Headless, Straight	31	105-6185	1	Plate-Valve
4	106-8754	4	Bolt-HF	32	94-1907	1	Swashplate-Variable
5	106-8755	1	O-Ring	34	94-6922	1	Bearing-Thrust
6	106-8756	1	Charge Pump Kit	37	115-4458	1	Arm-Trunnion, Tapered Square
7	104-2122	1	Gerotor ASM	38	94-1910	1	Guide-Slot
8	106-8757	1	O-Ring	42	98-3252	2	Valve-Check (W/Poppet)
10	104-2111	2	Capscrew	44	106-8760	1	Charge Relief Valve Kit
15	106-8759	1	Bypass Valve Kit	49	114-8155	1	Trunnion Seal Kit
18	103-2664	1	Input Shaft Kit	56	106-8762	1	Plug-HSH
19	104-5311	1	Bearing-Ball	66	106-8763	1	Plug-HSH
20	104-5310	1	Seal-Lip	98	117-3629	1	Kit-Return
21	104-5308	1	Spacer	99	105-6184	1	Seal Overhaul Kit
22	104-5309	1	Ring-Retaining				
25	103-2666	1	Cylinder Block Kit				

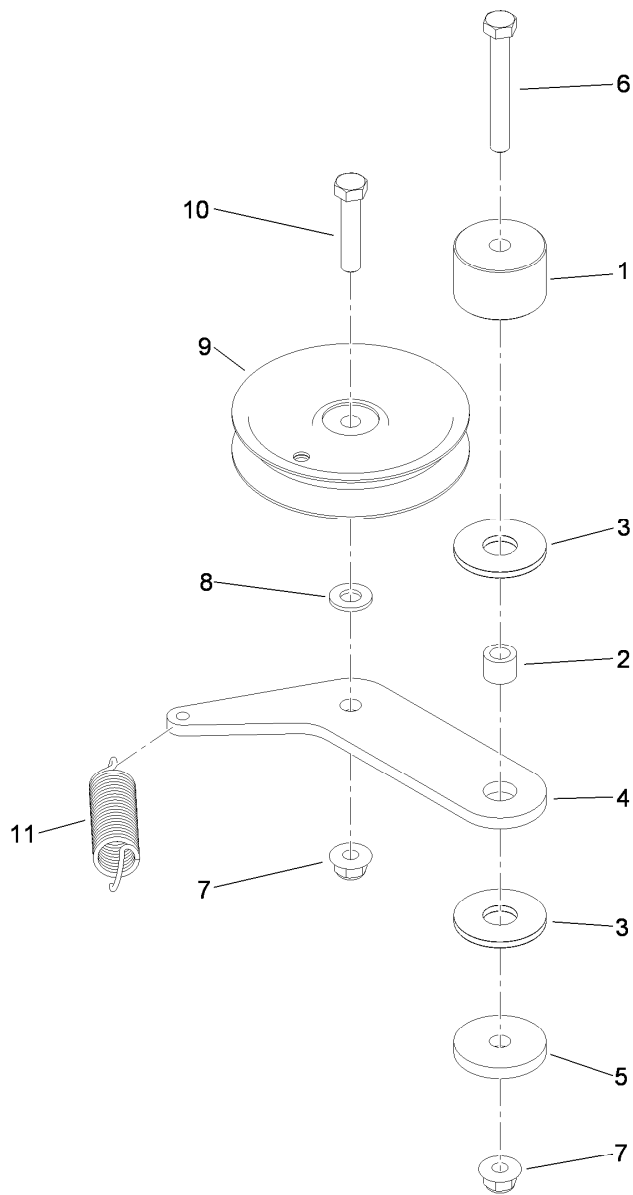

Pump Idler Assembly

<i>Ref.</i>	<i>Part Number</i>	<i>Qty.</i>	<i>Description</i>
1	117-3568	1	Hub-Idler
2	1-413088	1	Bushing-Lever, Lift
3	114-0463	2	Washer-Friction, Composite
4	117-9707	1	Plate-Idler
5	110-9981	1	Washer-Plain
6	323-13	1	Screw-HH
7	104-8301	2	Nut-Flange, NI
8	3256-24	1	Washer-Flat
9	93-1622	1	Pulley-Idler
10	323-9	1	Screw-HH
11	108-4056	1	Spring-Extension

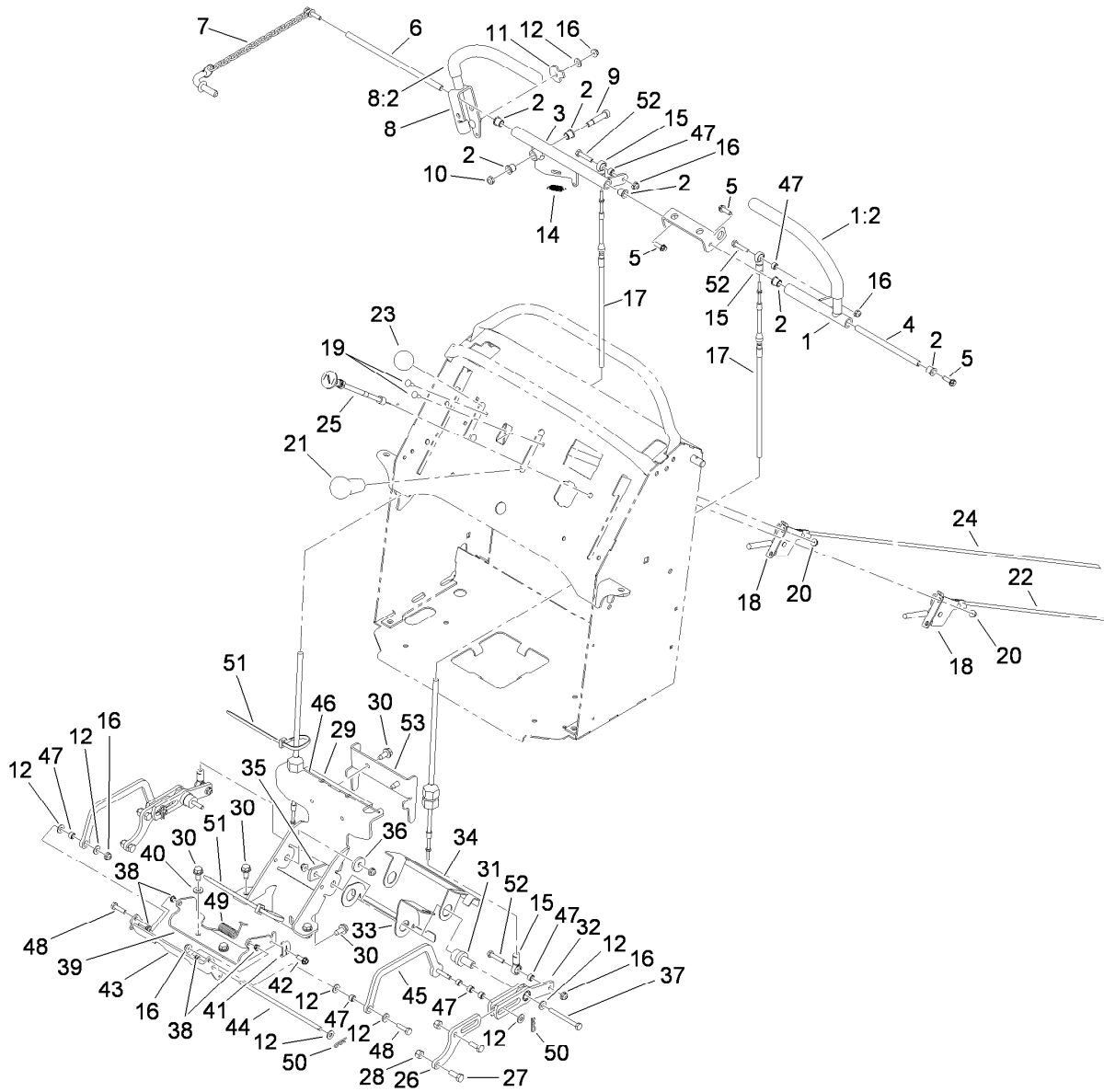

Control Assembly

Ref.	Part Number	Qty.	Description	Ref.	Part Number	Qty.	Description
1	119-7235	1	LH Lever ASM	21	99-7981	1	Knob-Grip, Soft
1:2	119-0222	1	Grip	22	117-9706	1	Cable-Speed
2	103-9928	6	Bearing	23	1-603175	1	Knob-Ball
3	119-7236	1	Motion Control ASM	24	119-6654	1	Cable-Throttle
4	114-0260	1	Shaft-Pivot	25	119-6655	1	Control-Choke, Push/Pull
5	80-0700	3	Screw-HH, Torx	26	114-3547	2	Arm-Control
6	114-1904	1	Shaft-Pivot, Motion Control	27	322-4	4	Screw-HH
7	114-0409	1	HOC Pin ASM	28	3296-29	4	Nut-Lock, NI
8	119-1887	1	RH Motion Lever ASM	29	119-2380-01	1	Mount-Linkage, Drive
8:2	119-0222	1	Grip	30	32144-70	7	Screw-HWHTF
9	114-0239	1	Screw-HSH	31	119-2381	2	Hub-Shoulder
10	3296-47	1	Nut-Lock, NI	32	119-2409	2	Control Fork ASM
11	114-0268	1	Cam-Lever	33	114-1993	1	Lever-Switch
12	3256-22	11	Washer-Flat	34	119-2414	1	Lever-Switch
14	114-0249	1	Spring-Extension	35	114-5155-03	1	Arm-Switch, Stop
15	117-6222	4	Rod End-Ball Joint	36	65-8270	1	Washer
16	104-7201	9	Nut-HF	37	321-14	2	Screw-HH
17	117-0474	2	Cable-Control, Traction	38	119-2404	4	Bushing-Flange, Split
18	110-5547	2	Control Lever ASM	39	117-2681	1	Bracket-Shifter
19	1-807533	4	Bolt-CARR	40	3256-23	2	Washer-Flat
20	3290-148	4	Nut-HF	41	106-7297	1	Clamp-Cable

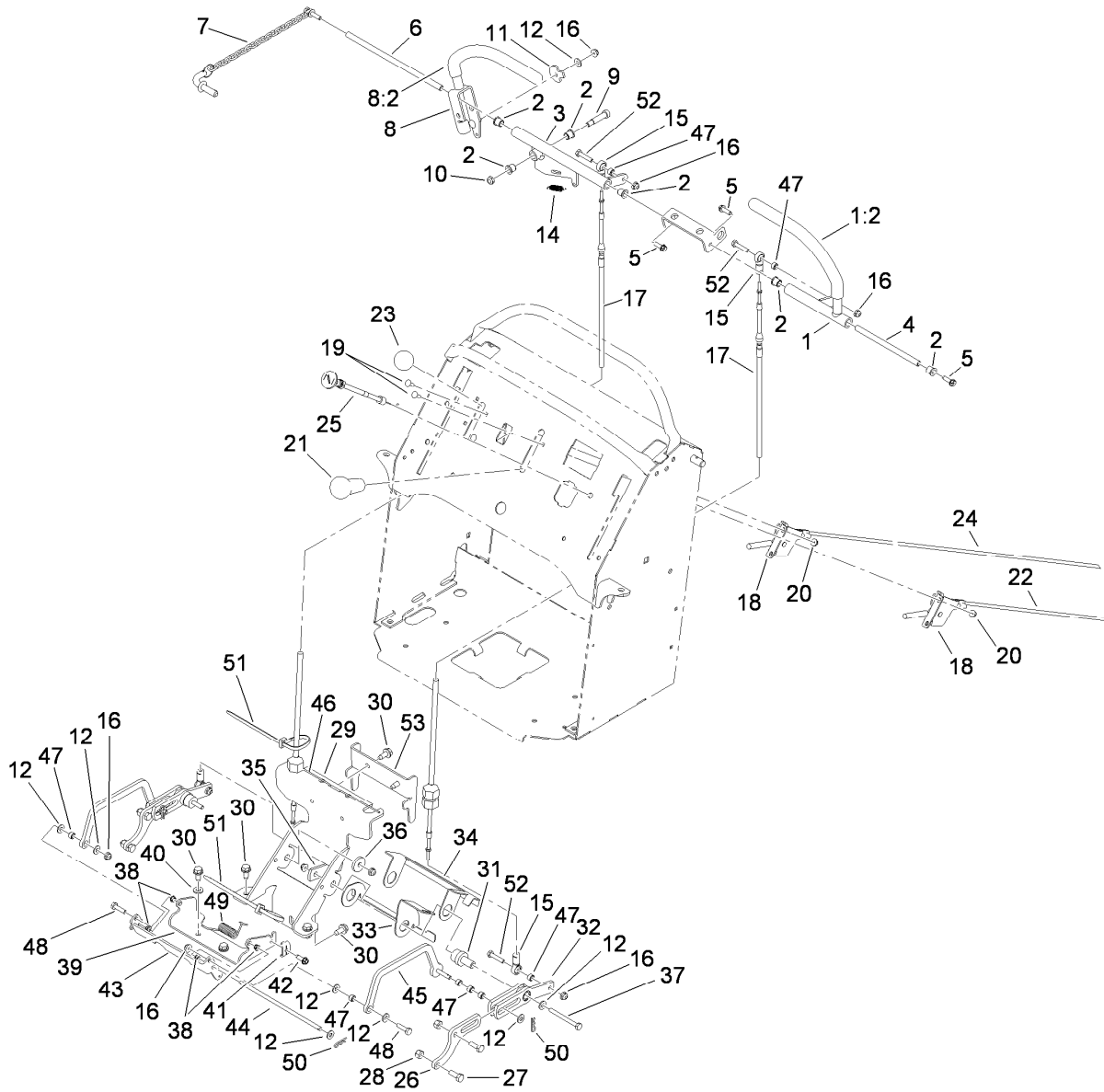

Control Assembly (continued)

<i>Ref.</i>	<i>Part Number</i>	<i>Qty.</i>	<i>Description</i>	<i>Ref.</i>	<i>Part Number</i>	<i>Qty.</i>	<i>Description</i>
42	49-2040	1	Screw-HWHTF	48	321-6	2	Screw-HH
43	117-2680	1	Arm-Dual, Shifter	49	106-2584	1	Spring-Torsion
44	114-1978	1	Pin-Hinge	50	3290-307	6	Pin-Hair
45	119-2402	2	Speed Control Linkage ASM	51	3290-378	2	Tie-Cable
46	114-0433	1	Clip-Spring	52	321-8	4	Screw-HH
47	119-2408	12	Bushing-Roller	53	119-8764-01	1	Bracket-Protect, Cable

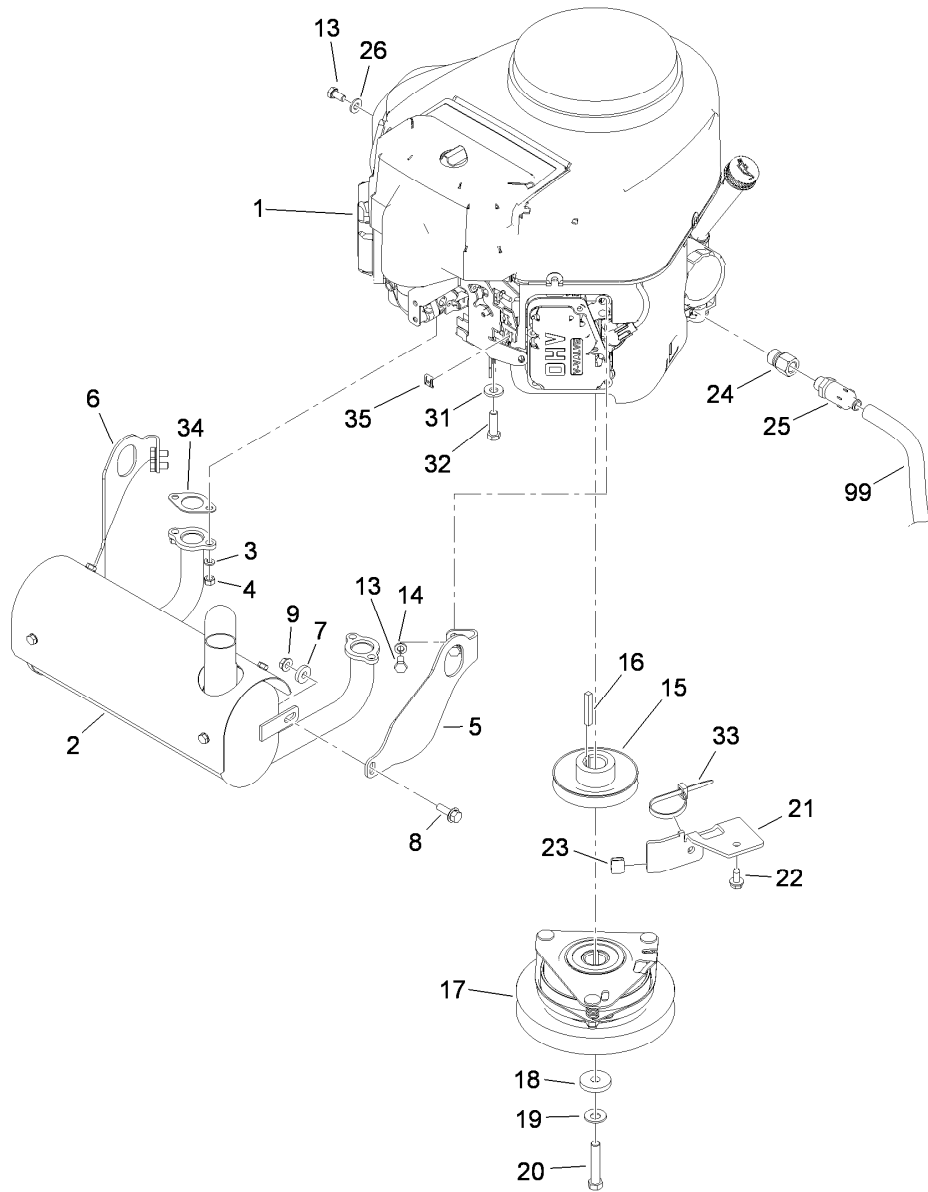

Engine Assembly

Ref.	Part Number	Qty.	Description	Ref.	Part Number	Qty.	Description
1		1	Engine-Kawasaki, Fs600V-As06 ●■	18	107-4136	1	Washer
2	116-2351	1	Muffler	19	1-603610	1	Washer-Spring
3	114-3550	4	Washer-Lock, Spring	20	3212-9	1	Screw-HH
4	114-3549	4	Nut	21	117-9708-01	1	Bracket-Stop, PTO
5	116-2353	1	Bracket-Muffler Mount, LH	22	32144-70	1	Screw-HWHTF
6	116-2354	1	Bracket-Muffler Mount, RH	23	109-3765	1	Bumper
7	104-7658	2	Spacer	24	103-1966	1	Adapter
8	3234-29	2	Screw-HHF	25	92-6877	1	Valve-Drain, Oil
9	32128-25	2	Nut-HF	26	33094-00	1	Washer-Plain
13	33114-016	5	Screw-HH	31	98-5975	4	Washer-Belleville
14	3253-4	4	Washer-Lock	32	323-7	4	Screw-HH
15	112-7067	1	Pulley	33	3290-378	1	Tie-Cable
16	608006	1	Key-Square	34	1-653313	2	Gasket-Exhaust
17	105-2635	1	Clutch / Brake ASM	35	81-1690	1	Clamp-Cable
				99	103-1964	1	Hose-Drain, Oil

● Not serviced separately

■ Obtain parts from www.kawpowerepc.com

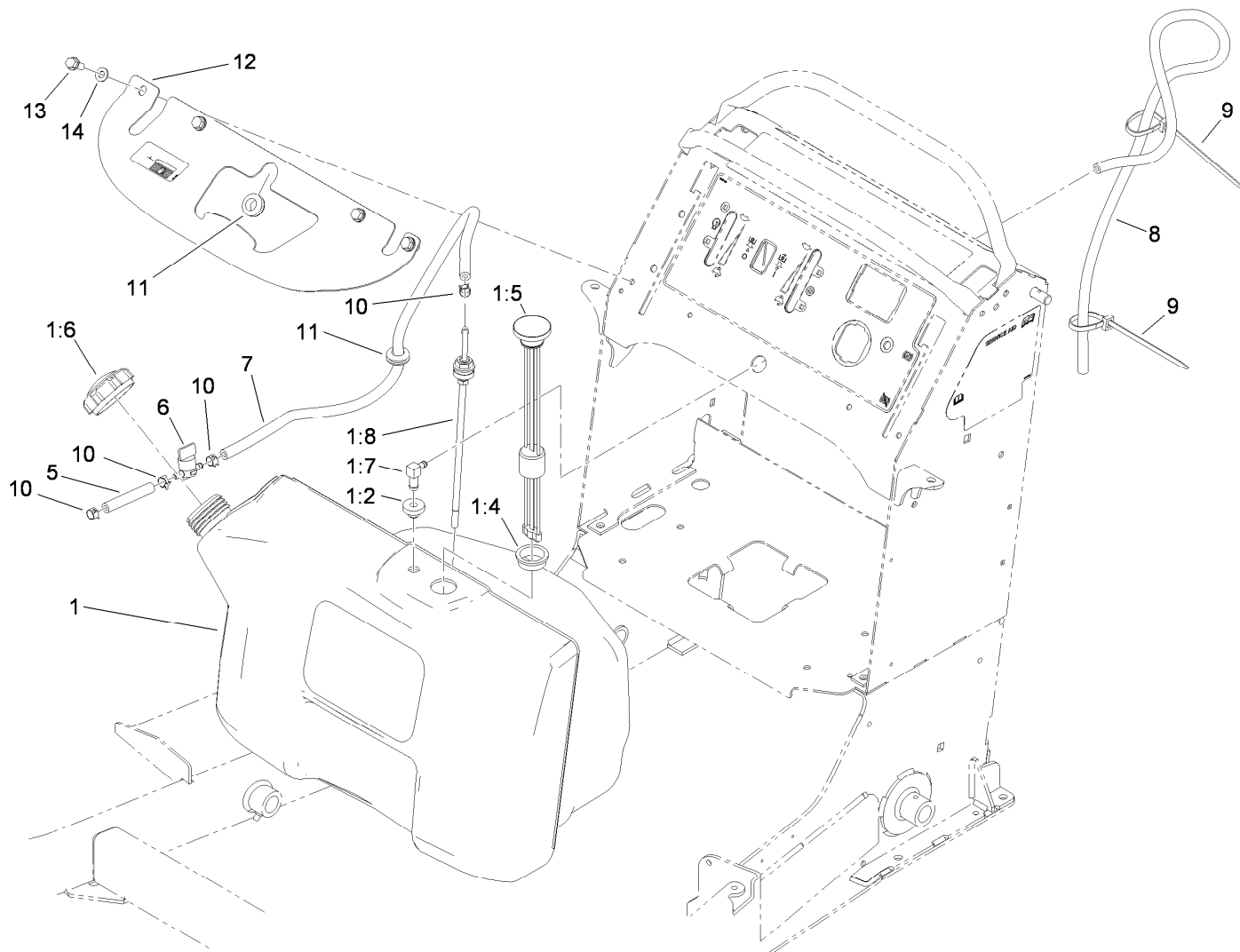

Fuel Tank Assembly

Ref.	Part Number	Qty.	Description
1	119-7295	1	Tank ASM
1:2	46-6560	1	Bushing
1:4	95-8972	1	Grommet
1:5	117-9719	1	Guage-Fuel
1:6	109-9619	1	Cap-Fuel
1:7	1-643172	1	Elbow-90 DEG
1:8	116-3408	1	Fitting-Fuel, Bulkhead
5	114-3765	1	Hose-Fuel
6	1-603770	1	Valve-Fuel

Ref.	Part Number	Qty.	Description
7	109-3491	1	Hose-Fuel
8	110-3372	1	Hose-Fuel
9	3290-378	2	Tie-Cable
10	2412-98	4	Clamp
11	112-7069	2	Grommet
12	116-3125	1	Bracket-Tank
13	32144-11	4	Screw-HWHTF
14	3256-70	4	Washer-Flat

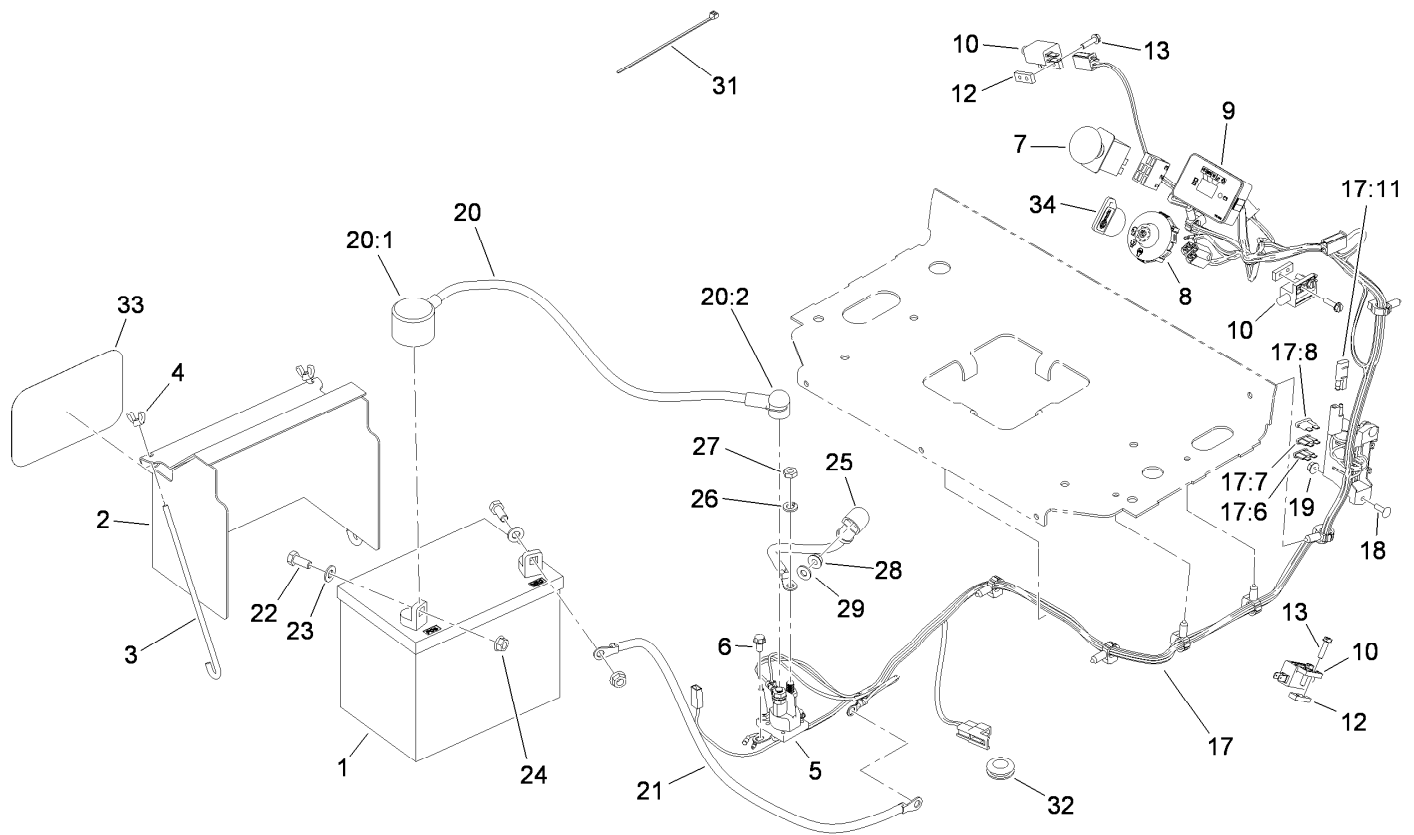

Electrical Assembly

<i>Ref.</i>	<i>Part Number</i>	<i>Qty.</i>	<i>Description</i>	<i>Ref.</i>	<i>Part Number</i>	<i>Qty.</i>	<i>Description</i>
1	104-2491	1	Battery	19	3290-148	2	Nut-HF
2	117-0543-01	1	Cover-Battery	20	109-7653	1	Positive Battery Cable ASM
3	1-633651	2	Bolt-Holddown	20:1	109-2407	1	Insulator-Battery
4	1-543792	2	Wingnut	20:2	1-543393	1	Insulator-Solenoid
5	117-1197	1	Solenoid	21	105-0836	1	Cable-Battery, Black
6	32144-4	2	Screw-HWH	22	322-3	2	Screw-HH
7	114-0279	1	Switch-PTO	23	3256-23	2	Washer-Flat
8	110-6764	1	Switch-Ignition	24	109-5715	2	Nut-HHF, Smooth
9	115-4180	1	Module-Meter, Hour	25	106-8268	1	Cable-Battery, Red
10	1-513152	3	Switch-Closed, Normally	26	3253-4	2	Washer-Lock
12	1-633181	3	Plate-Tapped	27	3220-2	2	Nut-Jam
13	32105-13	6	Screw-HWH	28	32128-33	1	Nut-HF
17	116-2662	1	Harness-Wiring	29	3256-22	1	Washer-Flat
17:6	109103	1	Fuse-Blade, 30 Amp	31	1-303287	2	Tie-Cable
17:7	109102	1	Fuse-Blade, 25 Amp	32	112-7069	1	Grommet
17:8	218-578	1	Fuse-Blade, 10 Amp	33	68-3640	1	Decal
17:11	116-0053	1	Cap-Plug	34	63-8360	1	Key-Ignition
18	1-807533	2	Bolt-CARR				

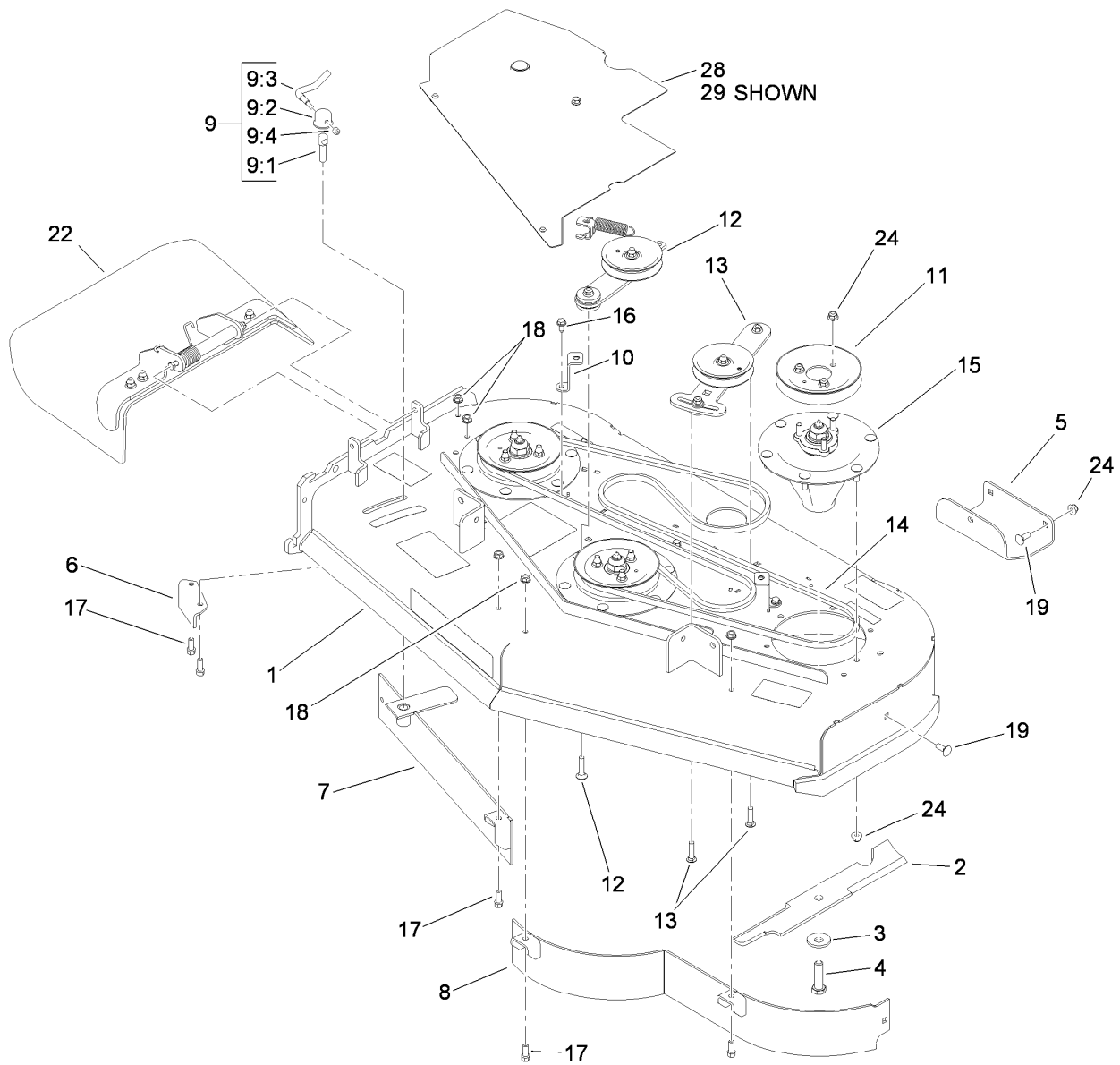

Deck Assembly

<i>Ref.</i>	<i>Part Number</i>	<i>Qty.</i>	<i>Description</i>	<i>Ref.</i>	<i>Part Number</i>	<i>Qty.</i>	<i>Description</i>
1	119-7262	1	Deck ASM	11	115-7440	3	Pulley
2	107-3192-03	3	Blade-16.5 Inch (High Flow)	12	117-0445	1	Spring Idler ASM
3	103-0865	3	Washer-Blade Bolt, Heavy	13	117-0446	1	Idler Adjust ASM
4	51-4060	3	Screw-Blade	14	114-0453	1	Belt-V
5	114-1908-01	1	Skid	15	117-6158	3	Spindle ASM
6	107-8541-01	1	Baffle-Discharge	16	32144-70	2	Screw-HWHTF
7	114-1870-01	1	Baffle ASM	17	92-1624	5	Screw-HWH
8	117-0410-01	1	48 Inch Baffle ASM	18	3290-357	5	Nut-HHF, Whiz
9	107-1664	1	Lever ASM	19	3231-2	4	Screw-CARR
9:1	106-3239	1	Screw-Lock	22	114-1910	1	Deflector ASM
9:2	107-1644	1	Cap-Lock	24	104-8301	31	Nut-Flange, NI
9:3	106-3241	1	Lever-Lock	28	119-7268	1	LH Belt Cover ASM
9:4	3296-29	1	Nut-Lock, NI	29	119-7269	1	RH Belt Cover ASM
10	119-7272-01	2	Belt Cover Bracket ASM				

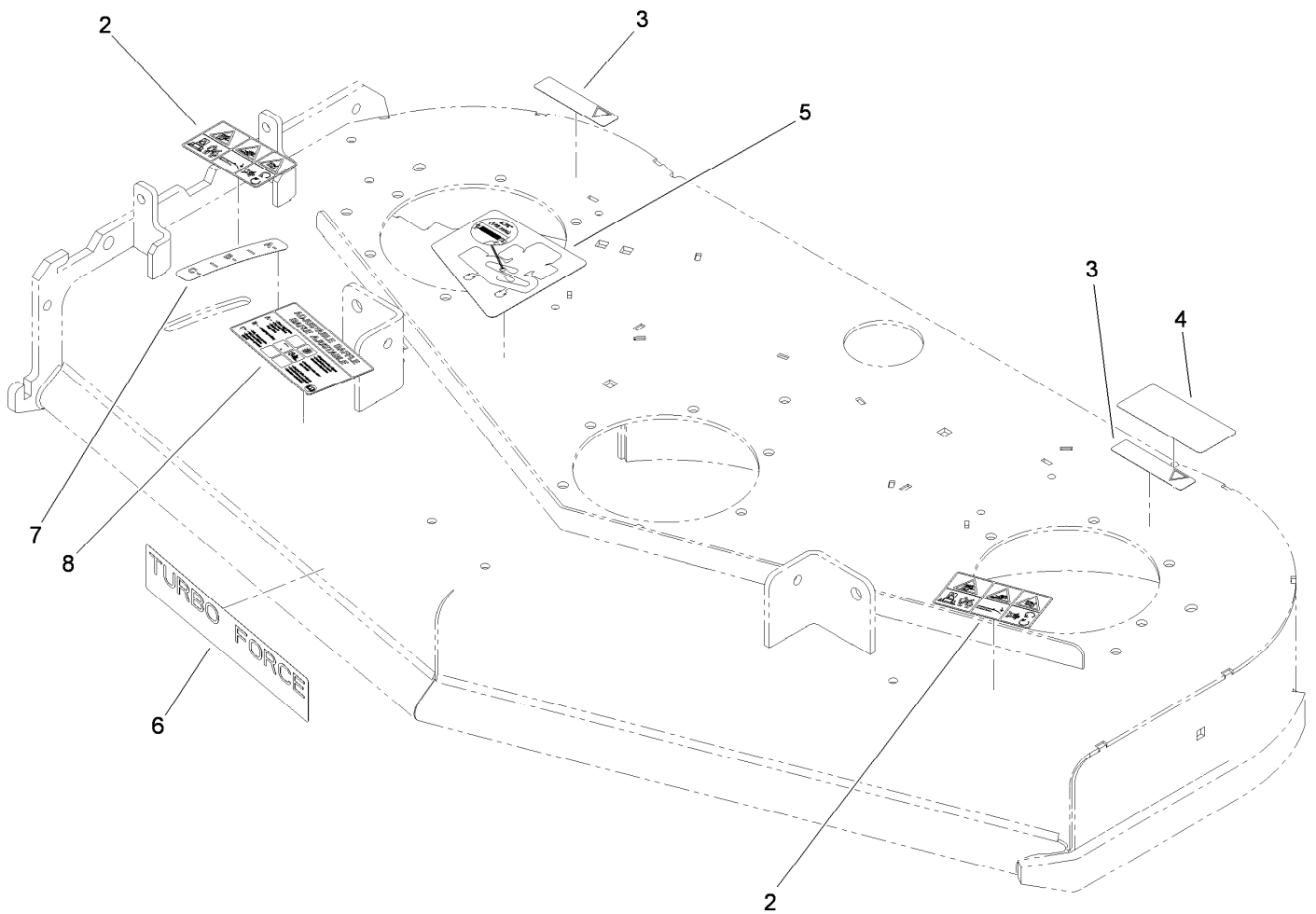

Deck Assembly No. 119-7262

Ref.	Part Number	Qty.	Description
2	93-7010	2	Decal-Danger
3	98-1977	2	Decal-Warning
4	93-7818	1	Decal-Torque, Blade Bolt
5	117-3628	1	Decal-Belt Routing, Ce
6	107-1690	1	Decal
7	110-2067	1	Decal-Setting, Baffle
8	110-2068	1	Decal-Adjustment, Baffle

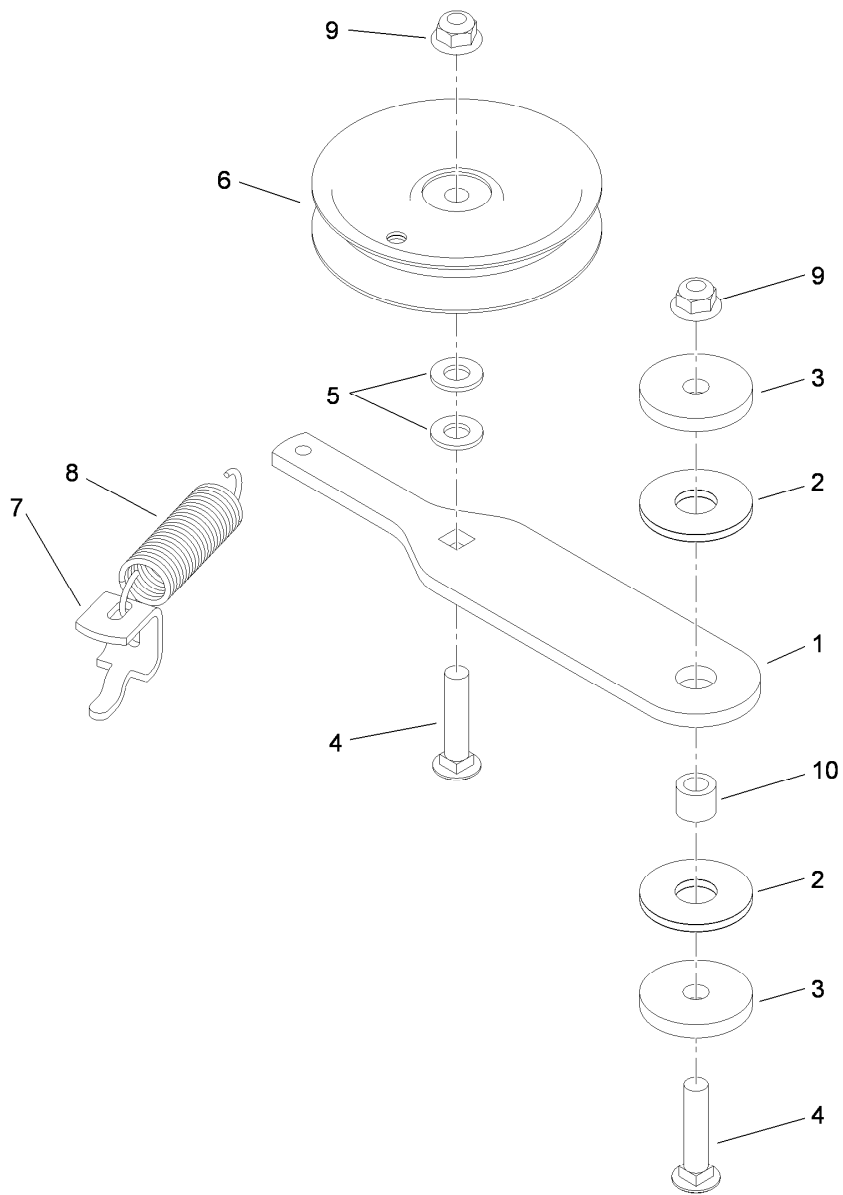

Spring Idler Assembly No. 117-0445

Ref.	Part Number	Qty.	Description
1	114-1992	1	Plate-Idler
2	114-0463	2	Washer-Friction, Composite
3	110-9981	2	Washer-Plain
4	3231-5	2	Screw-CARR
5	3256-24	2	Washer-Flat
6	93-1622	1	Pulley-Idler
7	117-0447-01	1	Bracket-Anchor, Spring
8	108-4056	1	Spring-Extension
9	104-8301	2	Nut-Flange, NI
10	1-413088	1	Bushing-Lever, Lift

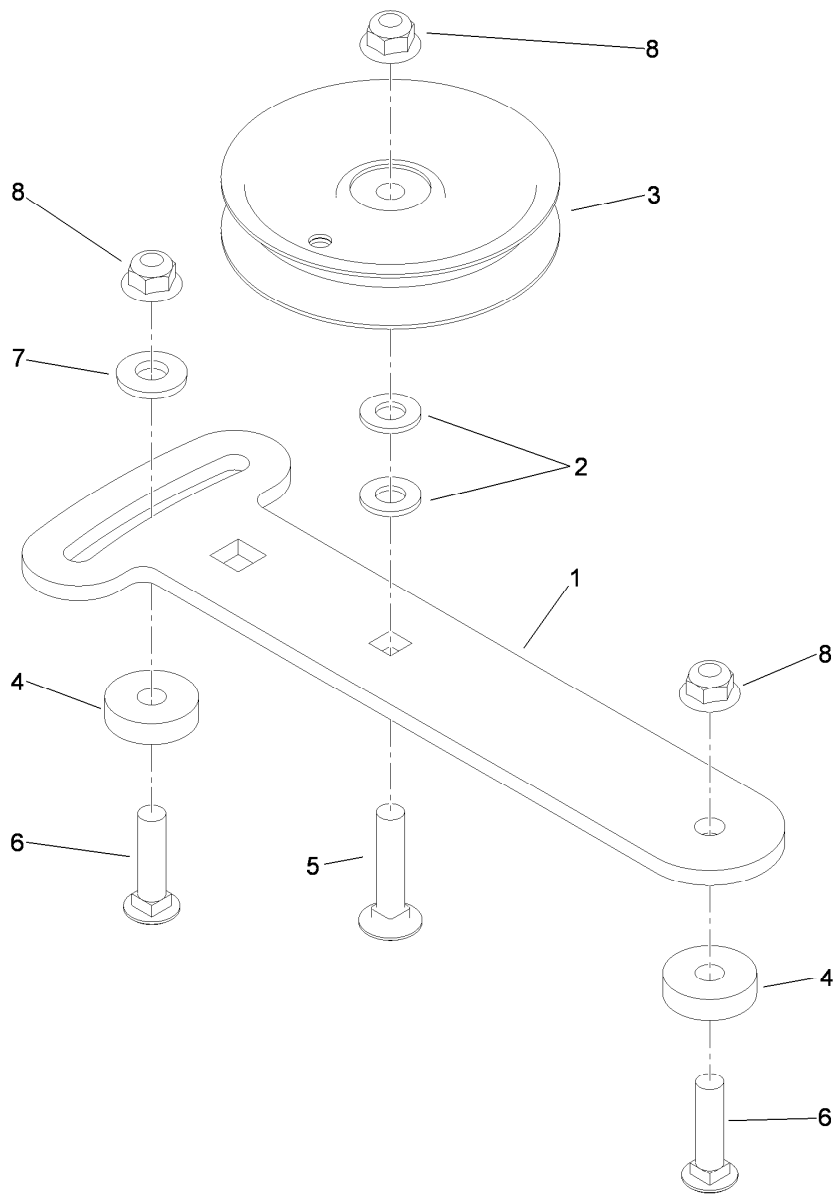

Idler Adjust Assembly No. 117-0446

<i>Ref.</i>	<i>Part Number</i>	<i>Qty.</i>	<i>Description</i>
1	114-1991	1	Plate-Idler
2	3256-24	2	Washer-Flat
3	93-1622	1	Pulley-Idler
4	105-7788	2	Spacer
5	3231-5	1	Screw-CARR
6	3231-4	2	Screw-CARR
7	98-5975	1	Washer-Belleville
8	104-8301	3	Nut-Flange, NI

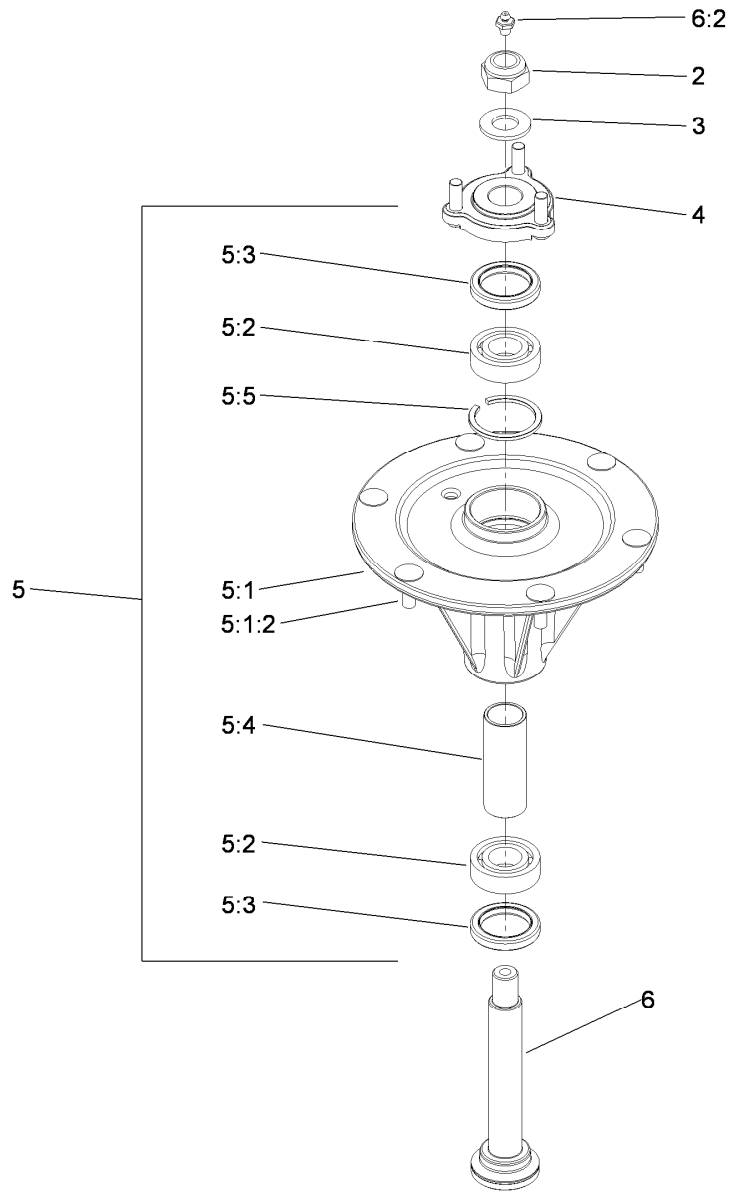

Spindle Assembly No. 117-6158

Ref.	Part Number	Qty.	Description
2	3296-67	1	Nut-Lock, NI
3	92-5836	1	Washer
4	117-6172	1	Spindle Hub ASM (W/Studs)
5		1	Spindle Housing And Ball Bearing ASM
5:1		1	Spindle Housing And Studs ASM ●
5:1:2	114-8195	6	Bolt-Ribbed Neck
5:2	76-7500	2	Bearing-Ball
5:3	253-133	2	Seal-Oil
5:4	117-6184	1	Spacer
5:5	114-8161	1	Ring-Snap
6	119-1851	1	Spindle Shaft And Zerk ASM
6:2	302-2	1	Fitting-Grease

● Not serviced separately

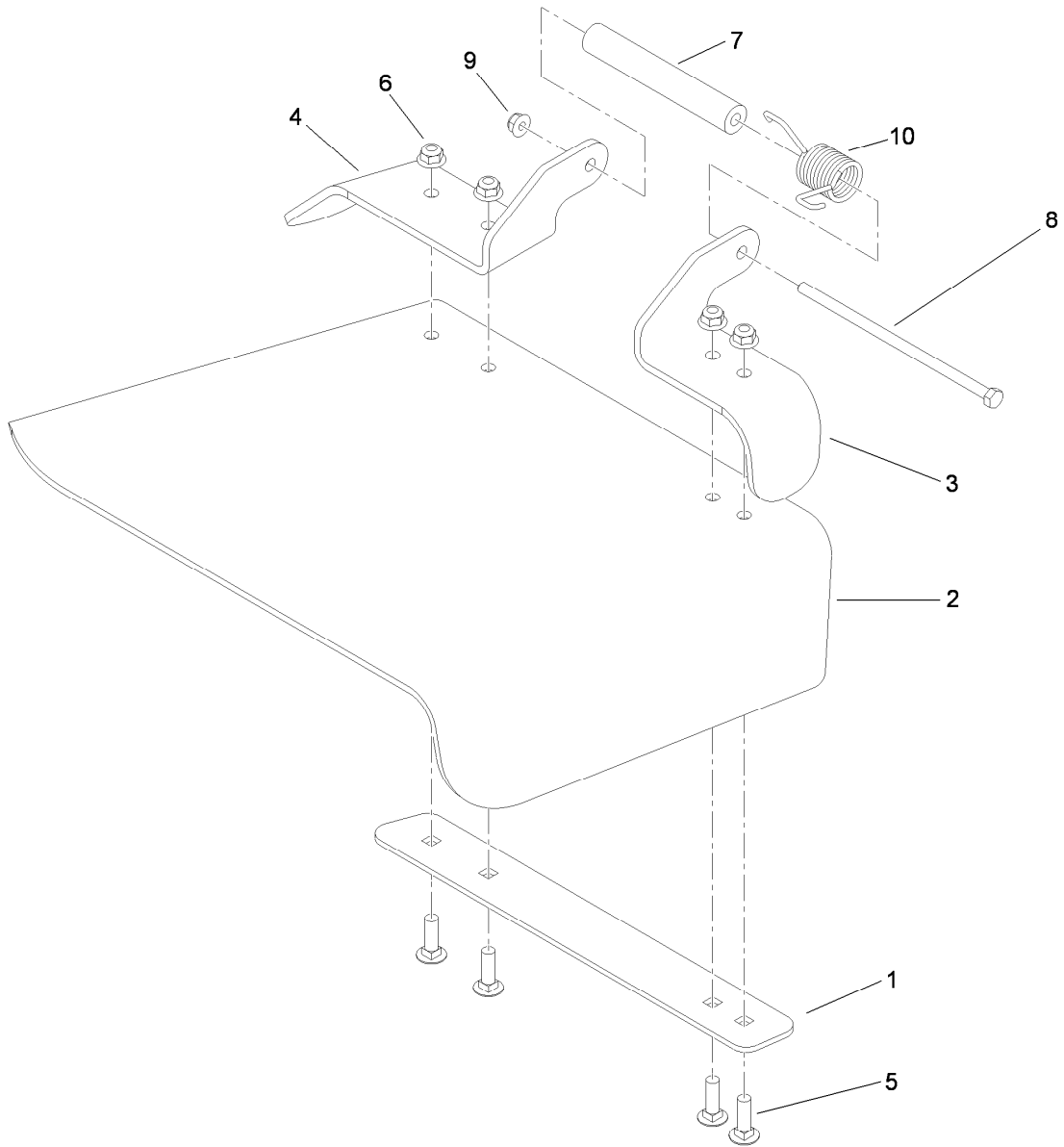

Deflector Assembly No. 114-1910

Ref.	Part Number	Qty.	Description
1	106-3248-03	1	Strap-Discharge
2	110-0759	1	Deflector-Rubber
3	108-7766-03	1	Bracket-Hinge, Front
4	108-7767-03	1	Bracket-Hinge, Rear
5	3231-25	4	Screw-CARR
6	104-8301	4	Nut-Flange, NI
7	105-4622	1	Spacer
8	322-50	1	Screw-HH
9	104-8300	1	Nut-Flange, NI
10	108-4052	1	Spring-Torsion

Attachments and Accessories

For 74568TE GrandStand Mower With 122cm TURBO FORCE Cutting Unit

Product Name	Model/Part
Standard High Lift Blade	107-3192-03
Blade-Low Flow, 16.5 inch	107-3193-03
Blade-Mid Flow, 16.5 inch.....	107-3194-03
Blade-Atomic, 16.5 inch.....	107-3195-03
Blade-Recycling, 16.5 inch	107-3196-03
Bagging Enhancement Kit	108-4091
Blade-Hi Flow, 16.5 inch (6 Pack)	110-0414
Blade-Lo Flow, 16.5 inch (6 Pack)	110-0415
Blade-Recycler, 16.5 inch (6 Pack).....	110-0416
Blade-Atomic, 16.5 inch (6 Pack).....	110-0417
Blade-Mid Flow, 16.5 inch (6 Pack).....	110-0418
Weight-Cast.....	112-7059-01
Light Kit.....	114-3505
Striping Kit	114-3521
Hypr-Oil 500 (quart).....	114-4713
Hypr-Oil 500 (gallon).....	114-4714
Hypr-Oil 500-5 (5 gallon).....	114-4715
Recycler Kit	117-0540
Weight Kit	117-3620
Chute Gate Kit With Bag.....	119-7292
Trash Bag ASM	119-7293
Soft Bag (3 Bushel).....	30104

Notes:

Notes:



Count on it.