



# TX525 Compact Utility Loader

Model No. 22323—Serial No. 290000001 and Up

Model No. 22324—Serial No. 290000001 and Up

## Setup Instructions

### Charging the Battery

#### Warning

##### CALIFORNIA Proposition 65 Warning

Battery posts, terminals, and related accessories contain lead and lead compounds, chemicals known to the State of California to cause cancer and reproductive harm.  
Wash hands after handling.

1. Open the rear access cover.
2. Connect a charger to the battery (Figure 1) and charge it for a minimum of 1 hour at 6 to 10 amps. Do not overcharge the battery.

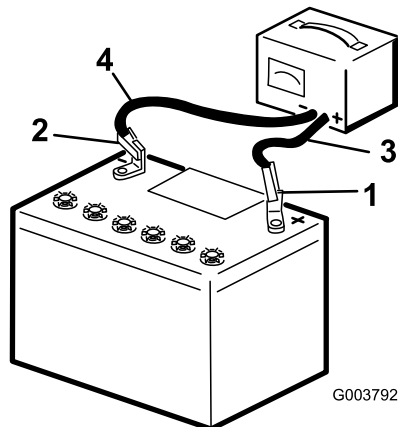

Figure 1

- |                  |                           |
|------------------|---------------------------|
| 1. Positive post | 3. Charger red (+) wire   |
| 2. Negative post | 4. Charger black (-) wire |

3. When the battery is fully charged, unplug the charger from the electrical outlet, then disconnect the charger leads from the battery posts (Figure 1).
4. Close the rear access cover.

### Checking Fluid Levels

Before starting the engine for the first time, check the engine oil and hydraulic fluid levels. Refer to the *Operator's Manual* for more information.

### Setting the Engine RPM (CE Only)

If you are setting up this machine for use in the European Community, you need to permanently adjust the engine speed so that it does not run above 3200 RPM, as follows:

1. Start the engine and run it at half throttle for 5 to 10 minutes to warm it up.

**Important:** The engine must be warm before making this adjustment.

2. Move the throttle lever to the Fast position.
3. Check the engine speed using a tachometer.

It should be around 3600 RPM.

4. Loosen the jam nut securing the high idle adjusting screw on the engine (located on the throttle cable support bracket—Figure 2).



Charging the battery produces gasses that can explode.

Never smoke near the battery and keep sparks and flames away from battery.

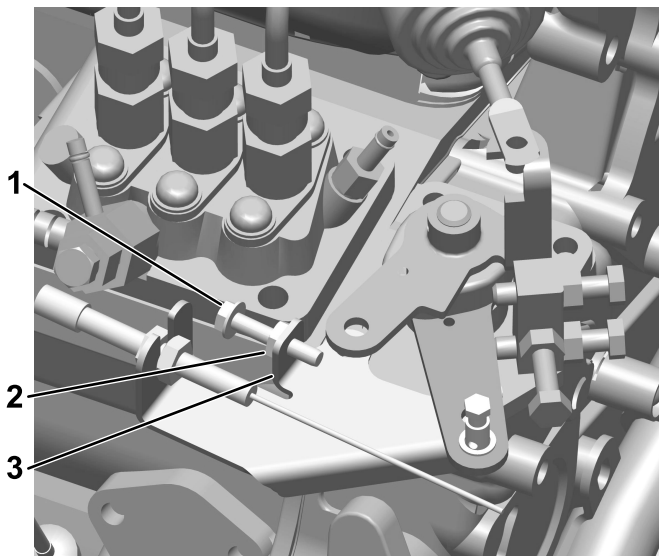

G009727

**Figure 2**

1. High idle adjusting screw    3. Throttle cable support bracket  
2. Jam nut

- 
5. Turn the high idle adjusting screw inward to lower the RPM to between 3100 and 3200 RPM.

**Important:** If you exceed 3200 RPM, the engine will not be in compliance with CE regulations and cannot be legally sold or used in the European Community.

6. Secure the screw with the jam nut, checking the engine RPM again as you do so.  
7. Slide the small aluminum tube over the high idle adjusting screw and jam nut.  
8. Crimp the tube down to the screw shaft with a pliers between the screw head and the jam nut so that the jam nut cannot be loosened in the future.

**Important:** The tube must be fully over the jam nut to prevent access to it.

## Installing the Production Year Decal (CE Only)

If you are setting up this machine for use in the European Community, you need to add the production year decal, found in the loose parts bag, to the machine. Install the decal just above the serial plate on the machine, following the instructions provided on the decal.